

High Power PIN Diode
50 MHz - 12 GHz

Rev. V1

Features

- 3 Terminal LPF Broadband Shunt Structure
- 50 MHz - 12 GHz Broadband Frequency
- >100 W Peak Power Handling
- < 0.1 dB Shunt Insertion Loss
- >23 dB Shunt Isolation
- < 45°C/W Thermal Resistance
- Lead-Free 1.5 x 1.2 mm 6-lead DFN Package
- RoHS* Compliant and 260°C Reflow

Description

The MADP-011027 is a lead-free 1.5 x 1.2 mm DFN surface mount plastic packaged that provides both low and high signal frequency operation from 50 MHz to 12 GHz. The higher breakdown voltage and lower thermal resistance of the PIN diode provides peak power handling in excess of 100 W.

This device is ideally suitable for usage in higher incident power switches, phase shifters, attenuators, and limiter microwave circuits over a broad frequency where higher performance surface mount diode assemblies are required.

Ordering Information^{1,2}

Part Number	Package
MADP-011027-14150T	3000 piece reel
MADP-011027-000SMB	sample board

1. Reference Application Note [M513](#) for reel size information.
2. All RF Sample boards include 5 loose parts.

Functional Schematic

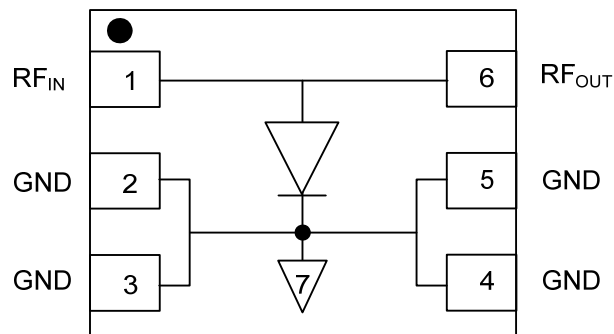

Pin Configuration³

Pin No.	Pin Name	Description
1	RF _{IN}	RF Input
2	GND	Ground
3	GND	Ground
4	GND	Ground
5	GND	Ground
6	RF _{OUT}	RF Output
7	Paddle ⁴	Ground

3. M/A-COM Technology Solutions recommends connecting unused package pins to ground.
4. The exposed pad centered on the package bottom must be connected to RF, DC, and thermal ground.

* Restrictions on Hazardous Substances, European Union Directive 2002/95/EC.

High Power PIN Diode
50 MHz - 12 GHz

Rev. V1

Electrical Specifications: T_A = +25°C

Parameter	Test Conditions	Units	Min.	Typ.	Max.
Forward Voltage	+50 mA D.C.	V	0.7	0.9	1.1
Reverse Leakage Current	-100 V D.C.	ηA	—	- 20	-1000
Total Capacitance ⁵	-50 V @ 1 MHz	pF	—	0.24	0.35
Series Resistance ⁶	+10 mA @ 1 GHz	Ω	—	1.9	2.6
Parallel Resistance ⁶	-Vdc = -40 V, @ 100 MHz	KΩ	—	500	—
Minority Carrier Lifetime	+If = 10 mA / -Ir = -6 mA (50% Control Voltage, 90% Output Voltage)	μS	—	1.0	2.0
C.W. Thermal Resistance (Infinite Heat Sink at Thermal Ground Plane)	IHigh = 4 A, Ilow = 10 mA @ 10 kHz	°C/W	—	45	—
Power Dissipation ^{7,8} (Infinite Heat Sink at Thermal Ground Plane)	+If = 50 mA @ 1 GHz	W	—	3.3	—
Insertion Loss	F = 1 GHz, -Vdc = -10 V	dB		-0.1	
Isolation	F = 1 GHz, +Ibias = +10 mA	dB		-23	-21

5. Ct (Total Capacitance) = CJ (Junction Capacitance) + Cp (Parasitic Package Capacitance).

6. Rs and Rp are measured on an HP4291A Impedance Analyzer.

7. De-rate power dissipation linearly by -22.2 mW/°C to 0 W @ +175°C: Pd (T) = Pd (+25°C) - ΔP = Pd (+25°C) - (22.2 mW/°C) (ΔT).

8. PD = ΔTj / Θ or PD=(IF + IRF) 2 (Rs), where IF is the forward bias DC current and IRF is the forward bias RMS RF current.

Absolute Maximum Ratings^{9,10}

Parameter	Absolute Maximum
D.C. Forward Voltage @ +250 mA	1.2 V
D.C. Forward Current	250 mA
D.C. Reverse Voltage	-100V
Junction Temperature ¹¹	+175°C
Operating Temperature	-65°C to +125°C
Storage Temperature	-65°C to +150°C
Re-flow Temperature	+260°C for 360 seconds

9. Exceeding any one or combination of these limits may cause permanent damage to this device.

10. M/A-COM Technology Solutions does not recommend sustained operation near these survivability limits.

11. Operating at nominal conditions with T_j ≤ +140°C will ensure MTTF > 1 x 10E6 hours.

Handling Procedures

Please observe the following precautions to avoid damage:

Static Sensitivity

These devices are sensitive to electrostatic discharge (ESD) and can be damaged by static electricity. Proper ESD control techniques should be used when handling these Class 2 devices.

High Power PIN Diode
50 MHz - 12 GHz

Rev. V1

PCB Layout

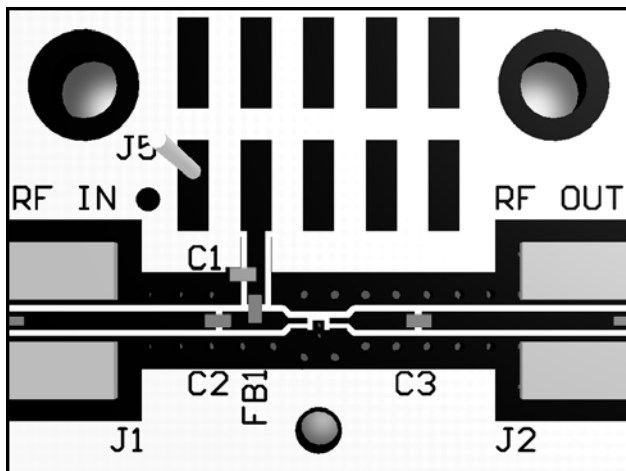

PCB Schematic

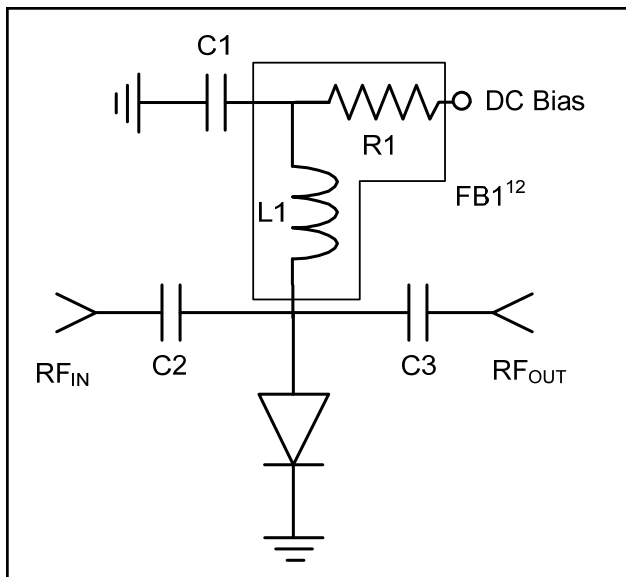

12. R1 is not needed when using the recommended ferrite FB1.

500 - 5000 MHz Parts List¹³

Part	Value	Case Style
C1	62 pF	0402
C2, C3	100 pF	0402
FB1	470 Ω @ 1 GHz	0402
R1	150 Ω	0402
L1	82 nH	0402

13. Max DC voltage with recommended components not to exceed 100 V.

Assembly Recommendations

Devices may be soldered using standard Pb60/Sn40, or RoHS compliant solders. Leads are plated NiPdAuAg to ensure an optimum solderable connection.

For recommended Sn/Pb and RoHS soldering profile See Application Note [M538](#) on the MACOM website.

Cleanliness and Storage

These devices should be handled and stored in a clean environment. Ends of the device are NiPdAuAg plated for greater solderability. Exposure to high humidity (>80%) for extended periods may cause the surface to oxidize. Caution should be taken when storing devices for long periods.

General Handling

Device can be handled with tweezers or vacuum pickups and are suitable for use with automatic pick-and-place equipment.

Typical 1 GHz Parametric Curves

Series Resistance vs. Forward Current

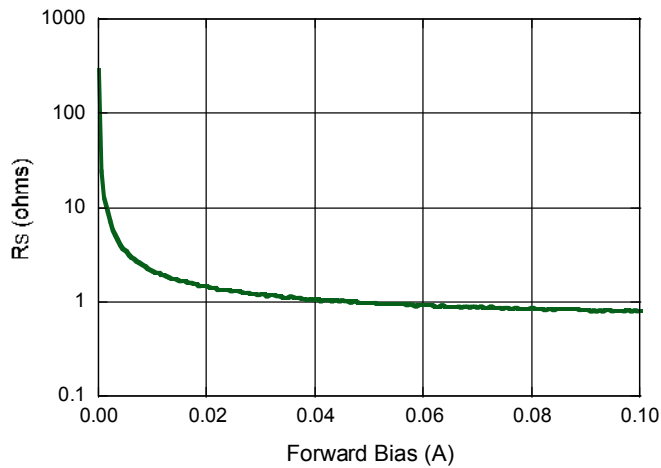

Capacitance vs. Reverse Voltage

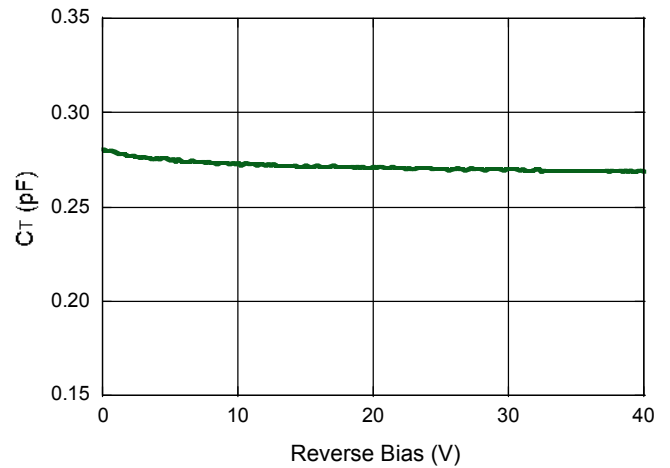

Parallel Resistance vs. Reverse Voltage

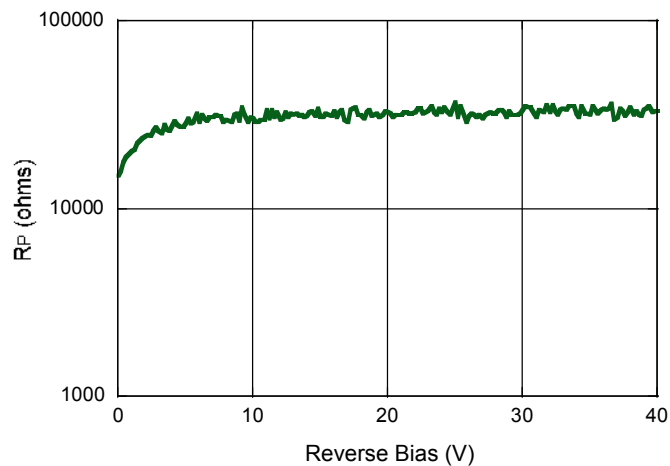

Typical RF Small Signal Performance Curves

Insertion Loss

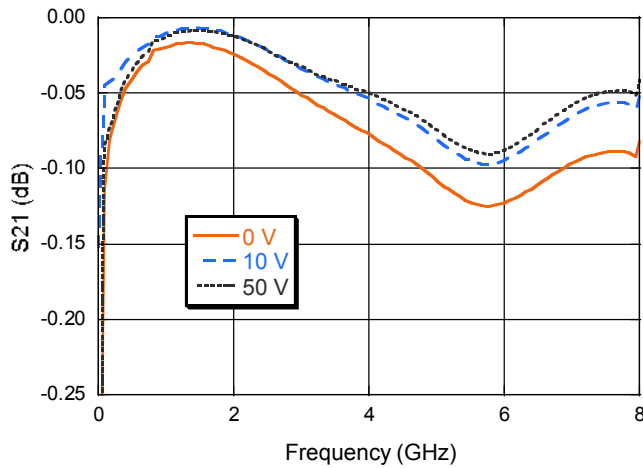

Return Loss

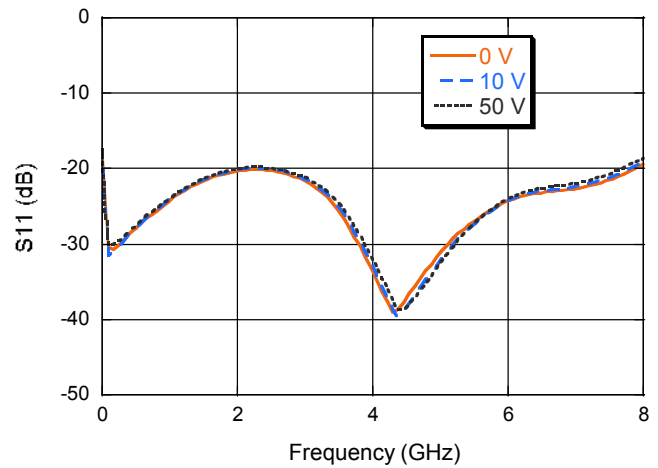

Isolation

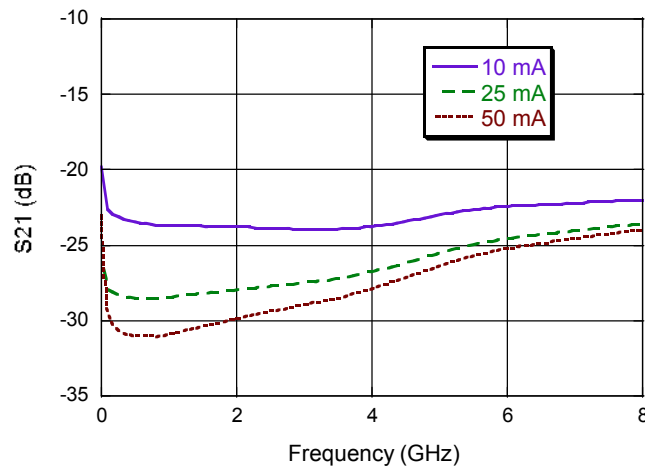

MADP-011027-14150T

High Power PIN Diode
50 MHz - 12 GHz

Rev. V1

Lead-Free 1.5 x 1.2 mm 6-Lead DFN[†]

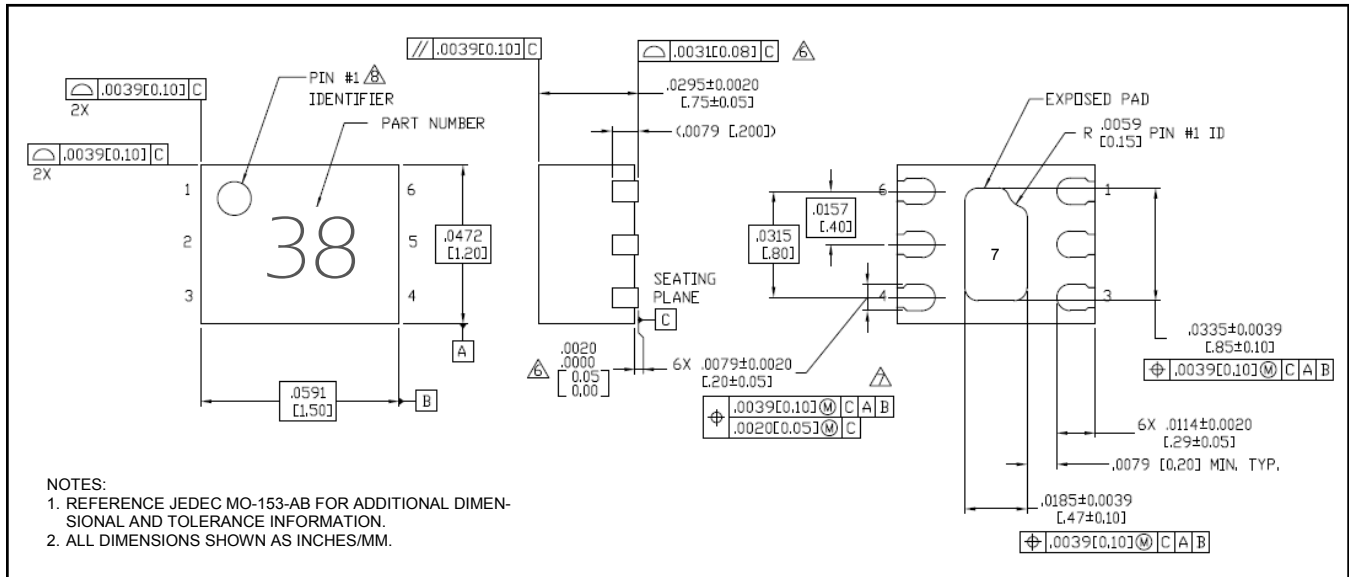

[†] Reference Application Note [S2083](#) for lead-free solder reflow recommendations.
Meets JEDEC moisture sensitivity level 1 requirements.
Plating is NiPdAuAg.

Applications Section

Schematic of High Power SP2T Shunt Switch using MADP-011027-14150T PIN Diodes
F = Octave Bandwidth from 1 to 12 GHz
P_{inc} = +40 dBm CW
P_{inc} = +50 dBm, 10 μS PW, 1 % Duty

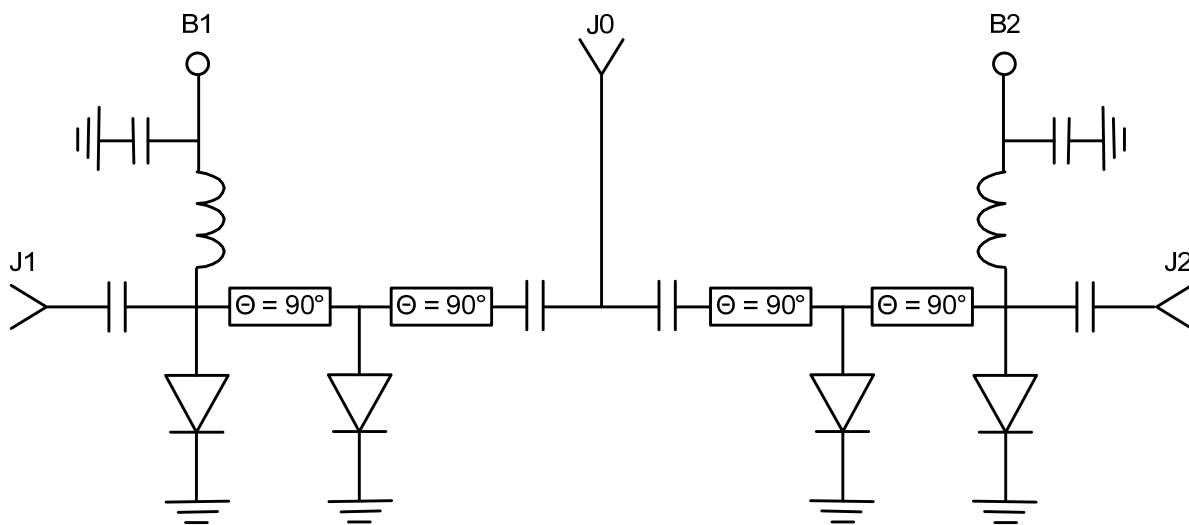

$$L = 11.807 / (\epsilon_{\text{eff}}^{1/2} * F * 4) \text{ inches, } \theta = \beta * L = (2 \pi / \lambda) * L = 90^\circ$$

Frequency is in GHz, ϵ_{eff} is Effective Dielectric Constant of Transmission Line Medium

RF State	B1 Bias	B2 Bias
J0-J1 Low Loss & J0-J2 Isolation	-50 V @ 0 mA	+1 V @ +20 mA
J0-J2 Low Loss & J0-J1 Isolation	+1 V @ +20 mA	-50 V @ 0 mA

Applications Section

Schematic of 3 Stage Limiter using MADP-011027-14150T
 $F = 1000 - 8,000 \text{ MHz}$
 $P_{inc} = +47 \text{ dBm CW}$
 $P_{inc} = +50 \text{ dBm, } 10 \mu\text{S P.W., } 1 \% \text{ Duty}$

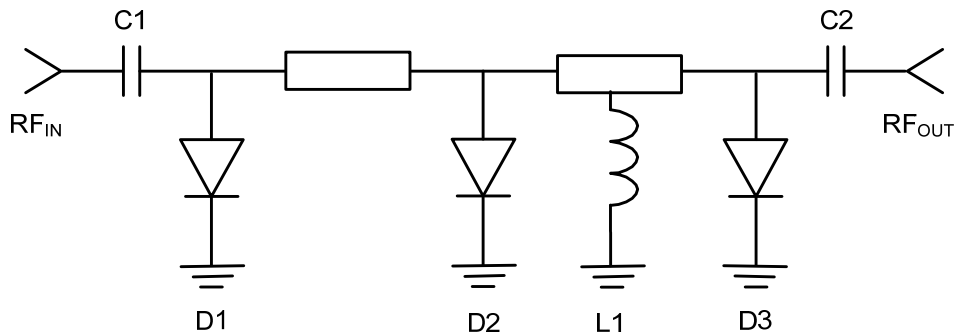

Part	PN	Case Style	Description	Quantity
D1	MADP-011027-14150T	ODS-1415	Input PIN Diode	1
D2	MADP-011023-14150T	ODS-1415	2nd Stage PIN Diode	1
D3	MADP-011023-14150T	ODS-1415	3rd Stage PIN Diode	1
L1	33 nH	0402	RF Choke / DC Return	1
C1	27 pF	0402	DC Block	1
C2	27 pF	0402	DC Block	1

Microwave Model of MADP-011027-14150T

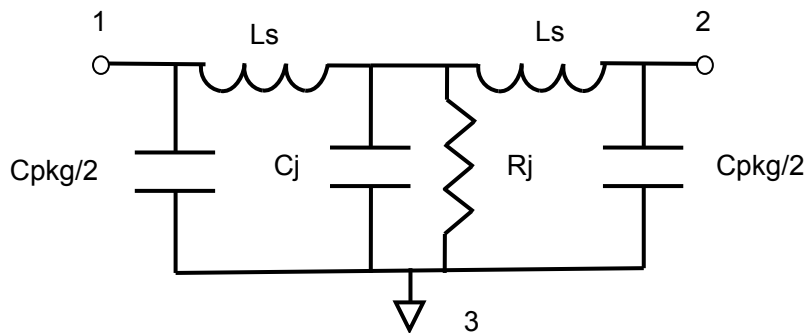
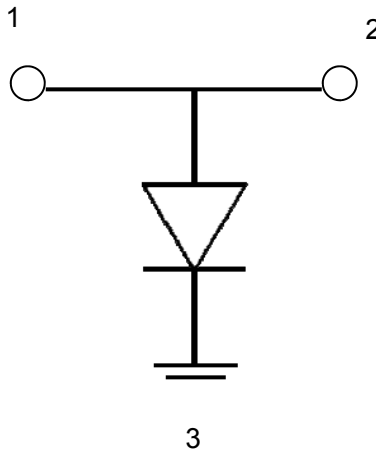

$R_j = R_s$ (Forward Bias Current)

$R_j = R_p$ (Reverse Bias Voltage)

Parameter	Value
Cpackage	8.0E-14 F
Lbond=Ls	4.0E-10 H
Rs	0.9 Ω
Rp	5E+5 Ω

Компания «Life Electronics» занимается поставками электронных компонентов импортного и отечественного производства от производителей и со складов крупных дистрибьюторов Европы, Америки и Азии.

С конца 2013 года компания активно расширяет линейку поставок компонентов по направлению коаксиальный кабель, кварцевые генераторы и конденсаторы (керамические, пленочные, электролитические), за счёт заключения дистрибьюторских договоров

Мы предлагаем:

- Конкуренеспособные цены и скидки постоянным клиентам.
- Специальные условия для постоянных клиентов.
- Подбор аналогов.
- Поставку компонентов в любых объемах, удовлетворяющих вашим потребностям.
- Приемлемые сроки поставки, возможна ускоренная поставка.
- Доставку товара в любую точку России и стран СНГ.
- Комплексную поставку.
- Работу по проектам и поставку образцов.
- Формирование склада под заказчика.
- Сертификаты соответствия на поставляемую продукцию (по желанию клиента).
- Тестирование поставляемой продукции.
- Поставку компонентов, требующих военную и космическую приемку.
- Входной контроль качества.
- Наличие сертификата ISO.

В составе нашей компании организован Конструкторский отдел, призванный помогать разработчикам, и инженерам.

Конструкторский отдел помогает осуществить:

- Регистрацию проекта у производителя компонентов.
- Техническую поддержку проекта.
- Защиту от снятия компонента с производства.
- Оценку стоимости проекта по компонентам.
- Изготовление тестовой платы монтаж и пусконаладочные работы.



Тел: +7 (812) 336 43 04 (многоканальный)

Email: org@lifeelectronics.ru