



Freescale Semiconductor

MC68331

User's Manual

Freescale Semiconductor, Inc.

© MOTOROLA, INC. 1996

© Freescale Semiconductor, Inc., 2004. All rights reserved.



How to Reach Us:

Home Page:

www.freescale.com

E-mail:

support@freescale.com

USA/Europe or Locations Not Listed:

Freescale Semiconductor
 Technical Information Center, CH370
 1300 N. Alma School Road
 Chandler, Arizona 85224
 +1-800-521-6274 or +1-480-768-2130
support@freescale.com

Europe, Middle East, and Africa:

Freescale Halbleiter Deutschland GmbH
 Technical Information Center
 Schatzbogen 7
 81829 Muenchen, Germany
 +44 1296 380 456 (English)
 +46 8 52200080 (English)
 +49 89 92103 559 (German)
 +33 1 69 35 48 48 (French)
support@freescale.com

Japan:

Freescale Semiconductor Japan Ltd.
 Headquarters
 ARCO Tower 15F
 1-8-1, Shimo-Meguro, Meguro-ku,
 Tokyo 153-0064
 Japan
 0120 191014 or +81 3 5437 9125
support.japan@freescale.com

Asia/Pacific:

Freescale Semiconductor Hong Kong Ltd.
 Technical Information Center
 2 Dai King Street
 Tai Po Industrial Estate
 Tai Po, N.T., Hong Kong
 +800 2666 8080
support.asia@freescale.com

For Literature Requests Only:

Freescale Semiconductor Literature Distribution Center
 P.O. Box 5405
 Denver, Colorado 80217
 1-800-441-2447 or 303-675-2140
 Fax: 303-675-2150
LDCForFreescaleSemiconductor@hibbertgroup.com

Information in this document is provided solely to enable system and software implementers to use Freescale Semiconductor products. There are no express or implied copyright licenses granted hereunder to design or fabricate any integrated circuits or integrated circuits based on the information in this document.

Freescale Semiconductor reserves the right to make changes without further notice to any products herein. Freescale Semiconductor makes no warranty, representation or guarantee regarding the suitability of its products for any particular purpose, nor does Freescale Semiconductor assume any liability arising out of the application or use of any product or circuit, and specifically disclaims any and all liability, including without limitation consequential or incidental damages. "Typical" parameters which may be provided in Freescale Semiconductor data sheets and/or specifications can and do vary in different applications and actual performance may vary over time. All operating parameters, including "Typicals" must be validated for each customer application by customer's technical experts. Freescale Semiconductor does not convey any license under its patent rights nor the rights of others. Freescale Semiconductor products are not designed, intended, or authorized for use as components in systems intended for surgical implant into the body, or other applications intended to support or sustain life, or for any other application in which the failure of the Freescale Semiconductor product could create a situation where personal injury or death may occur. Should Buyer purchase or use Freescale Semiconductor products for any such unintended or unauthorized application, Buyer shall indemnify and hold Freescale Semiconductor and its officers, employees, subsidiaries, affiliates, and distributors harmless against all claims, costs, damages, and expenses, and reasonable attorney fees arising out of, directly or indirectly, any claim of personal injury or death associated with such unintended or unauthorized use, even if such claim alleges that Freescale Semiconductor was negligent regarding the design or manufacture of the part.



TABLE OF CONTENTS

Paragraph	Title	Page
SECTION 1 INTRODUCTION		
SECTION 2 NOMENCLATURE		
2.1	Symbols and Operators	2-1
2.2	CPU32 Registers	2-2
2.3	Pin and Signal Mnemonics	2-3
2.4	Register Mnemonics	2-5
2.5	Conventions	2-6
SECTION 3 OVERVIEW		
3.1	MCU Features	3-1
3.1.1	System Integration Module (SIM)	3-1
3.1.2	Central Processing Unit (CPU32)	3-1
3.1.3	Queued Serial Module (QSM)	3-1
3.1.4	General-Purpose Timer (GPT)	3-2
3.2	System Block Diagram and Pin Assignment Diagrams	3-2
3.3	Pin Descriptions	3-5
3.4	Signal Descriptions	3-7
3.5	Intermodule Bus	3-10
3.6	System Memory Map	3-10
3.6.1	Internal Register Map	3-10
3.6.2	Address Space Maps	3-10
3.7	System Reset	3-16
3.7.1	SIM Reset Mode Selection	3-16
3.7.2	MCU Module Pin Function During Reset	3-17
SECTION 4 SYSTEM INTEGRATION MODULE		
4.1	General	4-1
4.2	System Configuration and Protection	4-2
4.2.1	Module Mapping	4-3
4.2.2	Interrupt Arbitration	4-3
4.2.3	Show Internal Cycles	4-4
4.2.4	Factory Test Mode	4-4
4.2.5	Register Access	4-4
4.2.6	Reset Status	4-4
4.2.7	Bus Monitor	4-4
4.2.8	Halt Monitor	4-5
4.2.9	Spurious Interrupt Monitor	4-5
4.2.10	Software Watchdog	4-5

TABLE OF CONTENTS

(Continued)

Paragraph	Title	Page
4.2.11	Periodic Interrupt Timer	4-7
4.2.12	Low-Power STOP Operation	4-8
4.2.13	Freeze Operation	4-9
4.3	System Clock	4-9
4.3.1	Clock Sources	4-10
4.3.2	Clock Synthesizer Operation	4-10
4.3.3	External Bus Clock	4-15
4.3.4	Low-Power Operation	4-15
4.3.5	Loss of Reference Signal	4-16
4.4	External Bus Interface	4-17
4.4.1	Bus Signals	4-18
4.4.1.1	Address Bus	4-18
4.4.1.2	Address Strobe	4-18
4.4.1.3	Data Bus	4-18
4.4.1.4	Data Strobe	4-18
4.4.1.5	Read/Write Signal	4-18
4.4.1.6	Size Signals	4-18
4.4.1.7	Function Codes	4-19
4.4.1.8	Data and Size Acknowledge Signals	4-19
4.4.1.9	Bus Error Signal	4-19
4.4.1.10	Halt Signal	4-20
4.4.1.11	Autovector Signal	4-20
4.4.2	Dynamic Bus Sizing	4-20
4.4.3	Operand Alignment	4-21
4.4.4	Misaligned Operands	4-21
4.4.5	Operand Transfer Cases	4-22
4.5	Bus Operation	4-22
4.5.1	Synchronization to CLKOUT	4-23
4.5.2	Regular Bus Cycles	4-23
4.5.2.1	Read Cycle	4-24
4.5.2.2	Write Cycle	4-25
4.5.3	Fast Termination Cycles	4-25
4.5.4	CPU Space Cycles	4-26
4.5.4.1	Breakpoint Acknowledge Cycle	4-27
4.5.4.2	LPSTOP Broadcast Cycle	4-30
4.5.5	Bus Exception Control Cycles	4-30
4.5.5.1	Bus Errors	4-32
4.5.5.2	Double Bus Faults	4-32
4.5.5.3	Retry Operation	4-33
4.5.5.4	Halt Operation	4-33
4.5.6	External Bus Arbitration	4-34



TABLE OF CONTENTS

(Continued)

Paragraph	Title	Page
4.5.6.1	Slave (Factory Test) Mode Arbitration	4-35
4.5.6.2	Show Cycles	4-35
4.6	Reset	4-36
4.6.1	Reset Exception Processing	4-36
4.6.2	Reset Control Logic	4-37
4.6.3	Reset Mode Selection	4-37
4.6.3.1	Data Bus Mode Selection	4-38
4.6.3.2	Clock Mode Selection	4-40
4.6.3.3	Breakpoint Mode Selection	4-40
4.6.4	MCU Module Pin Function During Reset	4-40
4.6.5	Pin State During Reset	4-41
4.6.5.1	Reset States of SIM Pins	4-41
4.6.5.2	Reset States of Pins Assigned to Other MCU Modules	4-42
4.6.6	Reset Timing	4-42
4.6.7	Power-On Reset	4-43
4.6.8	Reset Processing Summary	4-44
4.6.9	Reset Status Register	4-45
4.7	Interrupts	4-45
4.7.1	Interrupt Exception Processing	4-45
4.7.2	Interrupt Priority and Recognition	4-45
4.7.3	Interrupt Acknowledge and Arbitration	4-46
4.7.4	Interrupt Processing Summary	4-47
4.7.5	Interrupt Acknowledge Bus Cycles	4-48
4.8	Chip Selects	4-48
4.8.1	Chip-Select Registers	4-50
4.8.1.1	Chip-Select Pin Assignment Registers	4-51
4.8.1.2	Chip-Select Base Address Registers	4-52
4.8.1.3	Chip-Select Option Registers	4-52
4.8.1.4	PORTC Data Register	4-54
4.8.2	Chip-Select Operation	4-54
4.8.3	Using Chip-Select Signals for Interrupt Acknowledge	4-54
4.8.4	Chip-Select Reset Operation	4-55
4.9	Parallel Input/Output Ports	4-57
4.9.1	Pin Assignment Registers	4-57
4.9.2	Data Direction Registers	4-57
4.9.3	Data Registers	4-57
4.10	Factory Test	4-57

SECTION 5 CENTRAL PROCESSING UNIT

5.1	General	5-1
5.2	CPU32 Registers	5-2

TABLE OF CONTENTS

(Continued)

Paragraph	Title	Page
5.2.1	Data Registers	5-4
5.2.2	Address Registers	5-5
5.2.3	Program Counter	5-6
5.2.4	Control Registers	5-6
5.2.4.1	Status Register	5-6
5.2.4.2	Alternate Function Code Registers	5-6
5.2.5	Vector Base Register (VBR)	5-7
5.3	Memory Organization	5-7
5.4	Virtual Memory	5-9
5.5	Addressing Modes	5-9
5.6	Processing States	5-9
5.7	Privilege Levels	5-10
5.8	Instructions	5-10
5.8.1	M68000 Family Compatibility	5-14
5.8.2	Special Control Instructions	5-14
5.8.2.1	Low Power Stop (LPSTOP)	5-14
5.8.2.2	Table Lookup and Interpolate (TBL)	5-14
5.9	Exception Processing	5-14
5.9.1	Exception Vectors	5-15
5.9.2	Types of Exceptions	5-16
5.9.3	Exception Processing Sequence	5-17
5.10	Development Support	5-17
5.10.1	M68000 Family Development Support	5-17
5.10.2	Background Debugging Mode	5-18
5.10.2.1	Enabling BDM	5-19
5.10.2.2	BDM Sources	5-19
5.10.2.3	Entering BDM	5-20
5.10.2.4	BDM Commands	5-21
5.10.2.5	Background Mode Registers	5-21
5.10.2.6	Returning from BDM	5-22
5.10.2.7	Serial Interface	5-22
5.10.2.8	Recommended BDM Connection	5-24
5.10.3	Deterministic Opcode Tracking	5-24
5.10.4	On-Chip Breakpoint Hardware	5-25
5.11	Loop Mode Instruction Execution	5-25

SECTION 6 QUEUED SERIAL MODULE

6.1	General	6-1
6.2	QSM Registers and Address Map	6-2
6.2.1	QSM Global Registers	6-2
6.2.1.1	Low-Power Stop Operation	6-2



TABLE OF CONTENTS

(Continued)

Paragraph	Title	Page
6.2.1.2	Freeze Operation	6-3
6.2.1.3	QSM Interrupts	6-3
6.2.2	QSM Pin Control Registers	6-4
6.3	Queued Serial Peripheral Interface	6-5
6.3.1	QSPI Registers	6-6
6.3.1.1	Control Registers	6-7
6.3.1.2	Status Register	6-7
6.3.2	QSPI RAM	6-7
6.3.2.1	Receive RAM	6-8
6.3.2.2	Transmit RAM	6-8
6.3.2.3	Command RAM	6-8
6.3.3	QSPI Pins	6-8
6.3.4	QSPI Operation	6-9
6.3.5	QSPI Operating Modes	6-10
6.3.5.1	Master Mode	6-17
6.3.5.2	Master Wraparound Mode	6-19
6.3.5.3	Slave Mode	6-20
6.3.5.4	Slave Wraparound Mode	6-21
6.3.6	Peripheral Chip Selects	6-21
6.4	Serial Communication Interface	6-22
6.4.1	SCI Registers	6-22
6.4.1.1	Control Registers	6-22
6.4.1.2	Status Register	6-25
6.4.1.3	Data Register	6-25
6.4.2	SCI Pins	6-25
6.4.3	SCI Operation	6-25
6.4.3.1	Definition of Terms	6-26
6.4.3.2	Serial Formats	6-26
6.4.3.3	Baud Clock	6-26
6.4.3.4	Parity Checking	6-27
6.4.3.5	Transmitter Operation	6-27
6.4.3.6	Receiver Operation	6-29
6.4.3.7	Idle-Line Detection	6-29
6.4.3.8	Receiver Wakeup	6-30
6.4.3.9	Internal Loop	6-31
6.5	QSM Initialization	6-31

SECTION 7 GENERAL-PURPOSE TIMER

7.1	General	7-1
7.2	GPT Registers and Address Map	7-2
7.3	Special Modes of Operation	7-3

TABLE OF CONTENTS

(Continued)

Paragraph	Title	Page
7.3.1	Low-Power Stop Mode	7-3
7.3.2	Freeze Mode	7-3
7.3.3	Single-Step Mode	7-3
7.3.4	Test Mode	7-4
7.4	Polled and Interrupt-Driven Operation	7-4
7.4.1	Polled Operation	7-4
7.4.2	GPT Interrupts	7-5
7.5	Pin Descriptions	7-6
7.5.1	Input Capture Pins (IC[1:3])	7-6
7.5.2	Input Capture/Output Compare Pin (IC4/OC5)	7-6
7.5.3	Output Compare Pins (OC[1:4])	7-6
7.5.4	Pulse Accumulator Input Pin (PAI)	7-7
7.5.5	Pulse-Width Modulation (PWMA, PWMB)	7-7
7.5.6	Auxiliary Timer Clock Input (PCLK)	7-7
7.6	General-Purpose I/O	7-7
7.7	Prescaler	7-8
7.8	Capture/Compare Unit	7-9
7.8.1	Timer Counter	7-11
7.8.2	Input Capture Functions	7-11
7.8.3	Output Compare Functions	7-12
7.8.3.1	Output Compare 1	7-13
7.8.3.2	Forced Output Compare	7-13
7.9	Input Capture 4/Output Compare 5	7-13
7.10	Pulse Accumulator	7-14
7.11	Pulse-Width Modulation Unit	7-15
7.11.1	PWM Counter	7-16
7.11.2	PWM Function	7-17

APPENDIX A ELECTRICAL CHARACTERISTICS

APPENDIX B MECHANICAL DATA AND ORDERING INFORMATION

APPENDIX C DEVELOPMENT SUPPORT

C.1	M68MMDS1632 Modular Development System	C-1
C.2	M68MEVB1632 Modular Evaluation Board	C-2

APPENDIX D REGISTER SUMMARY

D.1	Central Processing Unit	D-1
D.1.1	CPU32 Register Model	D-2
D.1.2	— Status Register	D-3



TABLE OF CONTENTS

(Continued)

Paragraph	Title	Page
D.2	General-Purpose Timer	D-4
D.2.1	GPTMCR — GPT Module Configuration Register	D-4
D.2.2	GPTMTR — GPT Module Test Register (Reserved)	D-5
D.2.3	ICR — GPT Interrupt Configuration Register	D-5
D.2.4	DDRGP — Port GP Data Direction Register	D-6
D.2.5	OC1M— OC1 Action Mask Register	D-6
D.2.6	TCNT — Timer Counter Register	D-6
D.2.7	PACTL — Pulse Accumulator Control Register	D-7
D.2.8	TIC[1:3] — Input Capture Registers 1–3	D-8
D.2.9	TOC[1:4] — Output Compare Registers 1–4	D-8
D.2.10	TI4/O5 — Input Capture 4/Output Compare 5 Register	D-8
D.2.11	TCTL1/TCTL2 — Timer Control Registers 1 and 2	D-8
D.2.12	TMSK1/TMSK2 — Timer Interrupt Mask Registers 1 and 2	D-9
D.2.13	TFLG1/TFLG2 — Timer Interrupt Flag Registers 1 and 2	D-10
D.2.14	CFORC — Compare Force Register	D-10
D.2.15	PWMA/PWMB — PWM Registers A/B	D-12
D.2.16	PWMCNT — PWM Count Register	D-12
D.2.17	PWMBUFA — PWM Buffer Register A	D-12
D.2.18	PRESCL — GPT Prescaler	D-12
D.3	System Integration Module	D-13
D.3.1	SIMCR — Module Configuration Register	D-14
D.3.2	SIMTR — System Integration Test Register	D-15
D.3.3	SYNCR — Clock Synthesizer Control Register	D-15
D.3.4	RSR — Reset Status Register	D-16
D.3.5	SIMTRE — System Integration Test Register (ECLK)	D-17
D.3.6	PORTE0/PORTE1 — Port E Data Register	D-17
D.3.7	DDRE — Port E Data Direction Register	D-17
D.3.8	PEPAR — Port E Pin Assignment Register	D-17
D.3.9	PORTF0/PORTF1 — Port F Data Register	D-18
D.3.10	DDRF — Port F Data Direction Register	D-18
D.3.11	PFPAR — Port F Pin Assignment Register	D-18
D.3.12	SYPCR — System Protection Control Register	D-19
D.3.13	PICR — Periodic Interrupt Control Register	D-20
D.3.14	PITR — Periodic Interrupt Timer Register	D-20
D.3.15	SWSR — Software Service Register	D-21
D.3.16	TSTMSRA — Master Shift Register A	D-21
D.3.17	TSTMSRB — Master Shift Register B	D-21
D.3.18	TSTSC — Test Module Shift Count	D-21
D.3.19	TSTRC — Test Module Repetition Count	D-21
D.3.20	CREG — Test Submodule Control Register	D-21
D.3.21	DREG — Distributed Register	D-21



TABLE OF CONTENTS

(Continued)

Paragraph	Title	Page
D.3.22	PORTC — Port C Data Register	D-21
D.3.23	CSPAR0 — Chip Select Pin Assignment Register 0.....	D-21
D.3.24	CSPAR1 — Chip Select Pin Assignment Register 1.....	D-22
D.3.25	CSBARBT — Chip Select Base Address Register Boot ROM	D-23
D.3.26	CSORBT — Chip Select Option Register Boot ROM.....	D-23
D.4	Queued Serial Module	D-25
D.4.1	QSMCR — QSM Configuration Register	D-25
D.4.2	QTEST — QSM Test Register	D-26
D.4.3	QILR — QSM Interrupt Level Register.....	D-26
D.4.4	SCCR0 — SCI Control Register 0	D-27
D.4.5	SCCR1 — SCI Control Register 1.....	D-27
D.4.6	SCSR — SCI Status Register	D-29
D.4.7	SCDR — SCI Data Register.....	D-30
D.4.8	PORTQS — Port QS Data Register	D-30
D.4.9	PQSPAR — PORT QS Pin Assignment Register	D-30
D.4.10	SPCR0 — QSPI Control Register 0	D-32
D.4.11	SPCR1 — QSPI Control Register 1	D-33
D.4.12	SPCR2 — QSPI Control Register 2	D-34
D.4.13	SPCR3 — QSPI Control Register 3	D-34
D.4.14	RR[0:F] — Receive Data RAM.....	D-35
D.4.15	TR[0:F] — Transmit Data RAM	D-35
D.4.16	CR[0:F] — Command RAM.....	D-36



Freescale Semiconductor, Inc.

LIST OF ILLUSTRATIONS

Figure	Title	Page
3-1	MCU Block Diagram.....	3-3
3-2	Pin Assignments for 132-Pin Package.....	3-4
3-3	Pin Assignments for 144-Pin Package.....	3-5
3-4	Internal Register Memory Map.....	3-11
3-5	Overall Memory Map.....	3-12
3-6	Separate Supervisor and User Space Map.....	3-13
3-7	Supervisor Space (Separate Program/Data Space) Map.....	3-14
3-8	User Space (Separate Program/Data Space) Map.....	3-15
4-1	System Integration Module Block Diagram.....	4-2
4-2	System Configuration and Protection.....	4-3
4-3	Periodic Interrupt Timer and Software Watchdog Timer.....	4-7
4-4	System Clock Block Diagram.....	4-9
4-5	System Clock Oscillator Circuit.....	4-10
4-6	System Clock Filter Networks.....	4-11
4-7	MCU Basic System.....	4-17
4-8	Operand Byte Order.....	4-21
4-9	Word Read Cycle Flowchart.....	4-24
4-10	Write Cycle Flowchart.....	4-25
4-11	CPU Space Address Encoding.....	4-27
4-12	Breakpoint Operation Flowchart.....	4-29
4-13	LPSTOP Interrupt Mask Level.....	4-30
4-14	Bus Arbitration Flowchart for Single Request.....	4-35
4-15	Data Bus Mode Select Conditioning.....	4-39
4-16	Power-On Reset.....	4-44
4-17	Basic MCU System.....	4-49
4-18	Chip-Select Circuit Block Diagram.....	4-50
4-19	CPU Space Encoding for Interrupt Acknowledge.....	4-55
5-1	CPU32 Block Diagram.....	5-2
5-2	User Programming Model.....	5-3
5-3	Supervisor Programming Model Supplement.....	5-3
5-4	Data Organization in Data Registers.....	5-5
5-5	Address Organization in Address Registers.....	5-5
5-6	Memory Operand Addressing.....	5-8
5-7	Common In-Circuit Emulator Diagram.....	5-18
5-8	Bus State Analyzer Configuration.....	5-19
5-9	Debug Serial I/O Block Diagram.....	5-23
5-10	BDM Serial Data Word.....	5-24
5-11	BDM Connector Pinout.....	5-24
5-12	Loop Mode Instruction Sequence.....	5-25
6-1	QSM Block Diagram.....	6-1
6-2	QSPI Block Diagram.....	6-6

**LIST OF ILLUSTRATIONS
(Continued)**

Figure	Title	Page
6-3	QSPI RAM.....	6-7
6-4	Flowchart of QSPI Initialization Operation.....	6-11
6-5	Flowchart of QSPI Master Operation (Part 1)	6-12
6-5	Flowchart of QSPI Master Operation (Part 2)	6-13
6-5	Flowchart of QSPI Master Operation (Part 3)	6-14
6-6	Flowchart of QSPI Slave Operation (Part 1)	6-15
6-6	Flowchart of QSPI Slave Operation (Part 2)	6-16
6-7	SCI Transmitter Block Diagram.....	6-23
6-8	SCI Receiver Block Diagram.....	6-24
7-1	GPT Block Diagram.....	7-2
7-2	Prescaler Block Diagram.....	7-9
7-3	Capture/Compare Unit Block Diagram	7-10
7-4	Input Capture Timing Example.....	7-12
7-5	Pulse Accumulator Block Diagram	7-15
7-6	PWM Block Diagram	7-16
A-1	CLKOUT Output Timing Diagram.....	A-12
A-2	External Clock Input Timing Diagram.....	A-12
A-3	ECLK Output Timing Diagram.....	A-12
A-4	Read Cycle Timing Diagram	A-13
A-5	Write Cycle Timing Diagram.....	A-14
A-6	Fast Termination Read Cycle Timing Diagram	A-15
A-7	Fast Termination Write Cycle Timing Diagram.....	A-16
A-8	Bus Arbitration Timing Diagram — Active Bus Case	A-17
A-9	Bus Arbitration Timing Diagram — Idle Bus Case	A-18
A-10	Show Cycle Timing Diagram	A-18
A-11	Chip Select Timing Diagram.....	A-19
A-12	Reset and Mode Select Timing Diagram.....	A-19
A-13	Background Debugging Mode Timing Diagram—Serial Communication.....	A-21
A-14	Background Debugging Mode Timing Diagram —Freeze Assertion.....	A-21
A-15	ECLK Timing Diagram.....	A-23
A-16	QSPI Timing — Master, CPHA = 0	A-25
A-17	QSPI Timing — Master, CPHA = 1	A-25
A-18	QSPI Timing — Slave, CPHA = 0	A-26
A-19	QSPI Timing — Slave, CPHA = 1	A-26
B-1	132-Pin Plastic Surface Mount Package Pin Assignments	B-2
B-2	144-Pin Plastic Surface Mount Package Pin Assignments	B-3
D-1	User Programming Model	D-2
D-2	Supervisor Programming Model Supplement.....	D-2



Freescale Semiconductor, Inc.

LIST OF TABLES

Table	Title	Page
3-1	MCU Driver Types	3-6
3-2	MCU Pin Characteristics	3-6
3-3	MCU Power Connections	3-7
3-4	Signal Characteristics	3-7
3-5	Signal Function	3-8
3-6	SIM Reset Mode Selection	3-16
3-7	Module Pin Functions	3-17
4-1	Show Cycle Enable Bits	4-4
4-2	Bus Monitor Period	4-5
4-3	MODCLK Pin and SWP Bit During Reset	4-6
4-4	Software Watchdog Ratio	4-6
4-5	MODCLK Pin and PTP Bit at Reset	4-7
4-6	Periodic Interrupt Priority	4-8
4-7	Clock Control Multipliers	4-12
4-8	System Frequencies from 32.768-kHz Reference	4-14
4-9	Clock Control	4-16
4-10	Size Signal Encoding	4-19
4-11	Address Space Encoding	4-19
4-12	Effect of DSACK Signals	4-20
4-13	Operand Transfer Cases	4-22
4-14	DSACK, BERR, and HALT Assertion Results	4-31
4-15	Reset Source Summary	4-37
4-16	Reset Mode Selection	4-38
4-17	Module Pin Functions	4-41
4-18	SIM Pin Reset States	4-42
4-19	Chip-Select Pin Functions	4-51
4-20	Pin Assignment Field Encoding	4-51
4-21	Block Size Encoding	4-52
4-22	Option Register Function Summary	4-53
4-23	Chip Select Base and Option Register Reset Values	4-56
4-24	CSBOOT Base and Option Register Reset Values	4-57
5-1	Instruction Set Summary	5-11
5-2	Exception Vector Assignments	5-16
5-3	BDM Source Summary	5-19
5-4	Polling the BDM Entry Source	5-20
5-5	Background Mode Command Summary	5-21
5-6	CPU Generated Message Encoding	5-24
6-1	QSM Pin Function	6-4
6-2	QSPI Pin Function	6-9
6-3	BITS Encoding	6-18
6-4	SCI Pin Function	6-25



LIST OF TABLES
(Continued)

Table	Title	Page
6-5	Serial Frame Formats	6-26
6-6	Effect of Parity Checking on Data Size	6-27
7-1	GPT Status Flags	7-4
7-2	GPT Interrupt Sources	7-5
7-3	PWM Frequency Ranges Using 16.78-MHz/20.97-MHz System Clocks	7-17
A-1	Maximum Ratings	A-1
A-2	Typical Ratings, 16.78 MHz Operation	A-2
A-2	Typical Ratings, 20.97 MHz Operation	A-2
A-3	Thermal Characteristics	A-3
A-4	16.78 MHz Clock Control Timing	A-3
A-4	20.97 MHz Clock Control Timing	A-4
A-5	16.78 MHz DC Characteristics	A-5
A-5	20.97 MHz DC Characteristics	A-6
A-6	16.78 MHz AC Timing	A-8
A-6	20.97 MHz AC Timing	A-9
A-7	Background Debugging Mode Timing	A-20
A-8	16.78 MHz ECLK Bus Timing	A-22
A-8	20.97 MHz ECLK Bus Timing	A-22
A-9	QSPI Timing	A-24
B-1	MCU Ordering Information	B-4
B-2	Quantity Order Suffix	B-4
C-1	MC68331 Development Tools	C-1
D-1	Module Address Map	D-1
D-2	GPT Address Map	D-4
D-3	SIM Address Map	D-13
D-4	Port E Pin Assignments	D-18
D-5	Port F Pin Assignments	D-19
D-6	Software Watchdog Ratio	D-19
D-7	Bus Monitor Period	D-20
D-8	CSPAR0 Pin Assignments	D-22
D-9	CSPAR1 Pin Assignments	D-22
D-10	CSPAR0 and CSPAR1 Pin Assignment Field Encoding	D-22
D-11	Block Size Encoding	D-23
D-12	Option Register Function Summary	D-24
D-13	QSM Address Map	D-25
D-14	PQSPAR Pin Assignments	D-31
D-15	Effect of DDRQS on PORTQS Pins	D-31
D-16	Effect of DDRQS on QSM Pin Function	D-32
D-17	MC68331 Module Address Map	D-37
D-18	Register Bit and Field Mnemonics	D-40

Freescale Semiconductor, Inc.

SECTION 1 INTRODUCTION

The MC68331, a highly-integrated 32-bit microcontroller, combines high-performance data manipulation capabilities with powerful peripheral subsystems. The MCU is built up from standard modules that interface through a common intermodule bus (IMB). Standardization facilitates rapid development of devices tailored for specific applications.

The MCU incorporates a 32-bit CPU (CPU32), a system integration module (SIM), a general-purpose timer (GPT), and a queued serial module (QSM).

The MCU can either synthesize an internal clock signal from an external reference or use an external clock input directly. Operation with a 32.768-kHz reference frequency is standard. Because MCU operation is fully static, register and memory contents are not affected by a loss of clock.

High-density complementary metal-oxide semiconductor (HCMOS) architecture makes the basic power consumption of the MCU low. Power consumption can be minimized by stopping the system clock. The CPU32 instruction set includes a low-power stop (LPSTOP) command that efficiently implements this capability.

Documentation for the Modular Microcontroller Family follows the modular construction of the devices in the product line. Each microcontroller has a comprehensive user's manual that provides sufficient information for normal operation of the device. The user's manual is supplemented by module reference manuals that provide detailed information about module operation and applications. Refer to Freescale publication *Advanced Microcontroller Unit (AMCU) Literature* (BR1116/D) for a complete listing of documentation.

1



SECTION 2 NOMENCLATURE

The following nomenclature is used throughout the manual. Nomenclature used only in certain sections, such as register bit mnemonics, is defined in those sections.

2.1 Symbols and Operators

- + — Addition
- — Subtraction or negation (two's complement)
- * — Multiplication
- / — Division
- > — Greater
- < — Less
- = — Equal
- ≥ — Equal or greater
- ≤ — Equal or less
- ≠ — Not equal
- — AND
- ⊕ — Inclusive OR (OR)
- ⊕ — Exclusive OR (EOR)
- $\overline{\text{NOT}}$ — Complementation
- : — Concatenation
- ⇒ — Transferred
- ↔ — Exchanged
- ± — Sign bit; also used to show tolerance
- « — Sign extension
- % — Binary value
- \$ — Hexadecimal value

2.2 CPU32 Registers

- A6–A0 — Address registers (index registers)
- A7 (SSP) — Supervisor Stack Pointer
- A7 (USP) — User Stack Pointer
- CCR — Condition code register (user portion of SR)
- D7–D0 — Data Registers (index registers)
- DFC — Alternate function code register
- PC — Program counter
- SFC — Alternate function code register
- SR — Status register
- VBR — Vector base register
- X — Extend indicator
- N — Negative indicator
- Z — Zero indicator
- V — Two's complement overflow indicator
- C — Carry/borrow indicator

2.3 Pin and Signal Mnemonics

ADDR[23:0]	—	Address Bus
\overline{AS}	—	Address Strobe
\overline{AVEC}	—	Autovector
\overline{BERR}	—	Bus Error
\overline{BG}	—	Bus Grant
\overline{BGACK}	—	Bus Grant Acknowledge
\overline{BKPT}	—	Breakpoint
\overline{BR}	—	Bus Request
CLKOUT	—	System Clock
$\overline{CS[10:0]}$	—	Chip Selects
\overline{CSBOOT}	—	Boot ROM Chip Select
DATA[15:0]	—	Data Bus
\overline{DS}	—	Data Strobe
$\overline{DSACK[1:0]}$	—	Data and Size Acknowledge
DSCLK	—	Development Serial Clock
DSI	—	Development Serial Input
DSO	—	Development Serial Output
EXTAL	—	External Crystal Oscillator Connection
FC[2:0]	—	Function Codes
FREEZE	—	Freeze
\overline{HALT}	—	Halt
IC[4:1]	—	Input Capture
\overline{IFETCH}	—	Instruction Fetch
\overline{IPIPE}	—	Instruction Pipeline
$\overline{IRQ[7:1]}$	—	Interrupt Request
MISO	—	Master In Slave Out
MODCLK	—	Clock Mode Select
MOSI	—	Master Out Slave In
OC[5:1]	—	Output Compare
PAI	—	Pulse Accumulator Input
PC[6:0]	—	SIM I/O Port C
PCLK	—	Pulse Accumulator Clock
PCS[3:0]	—	Peripheral Chip Selects
PE[7:0]	—	SIM I/O Port E
PF[7:0]	—	SIM I/O Port F
PGP[7:0]	—	GPT I/O Port
PQS[7:0]	—	QSM I/O Port
PWMA, PWMB	—	Pulse Width Modulator Output
QUOT	—	Quotient Out

- R/W — Read/Write
- RESET — Reset
- RMC — Read-Modify-Write Cycle
- RXD — SCI Receive Data
- SCK — QSPI Serial Clock
- SIZ[1:0] — Size
- SS — Slave Select
- TSC — Three-State Control
- TXD — SCI Transmit Data
- XFC — External Filter Capacitor
- XTAL — External Crystal Oscillator Connection

2.4 Register Mnemonics

- CFORC — GPT Compare Force Register
- CREG — Test Control Register C
- CR[0:F] — QSM Command RAM
- CSBARBT — Chip-Select Base Address Register Boot ROM
- CSBAR[0:10] — Chip-Select Base Address Registers [0:10]
- CSORBT — Chip-Select Option Register Boot ROM
- CSOR[0:10] — Chip-Select Option Register [0:10]
- CSPAR[0:1] — Chip-Select Pin Assignment Registers [0:1]
- DDRE — Port E Data Direction Register
- DDRF — Port F Data Direction Register
- DDRGP — Port GP Data Direction Register
- DDRQS — Port QS Data Direction Register
- DREG — SIM Test Module Distributed Register
- GPTMCR — GPT Module Configuration Register
- ICR — GPT Interrupt Configuration Register
- OC1D — Output Compare 1 Action Data Register
- OC1M — Output Compare 1 Action Mask Register
- PACNT — Pulse Accumulator Counter
- PACTL — Pulse Accumulator Control Register
- PEPAR — Port E Pin Assignment Register
- PFPAR — Port F Pin Assignment Register
- PICR — Periodic Interrupt Control Register
- PITR — Periodic Interrupt Timer Register
- PORTC — Port C Data Register
- PORTE — Port E Data Register
- PORTF — Port F Data Register
- PORTGP — Port GP Data Register
- PORTQS — Port QS Data Register
- PQSPAR — Port QS Pin Assignment Register
- PRESCL — GPT Prescaler Register
- PWMA — PWM Control Register A
- PWMB — PWM Control Register B
- PWMBUFA — PWM Buffer Register A
- PWMBUFB — PWM Buffer Register B
- PWMC — PWM Control Register C
- PWMCNT — PWM Counter
- QILR — QSM Interrupt Level Register
- QIVR — QSM Interrupt Vector Register
- QSMCR — QSM Configuration Register

- QTEST — QSM Test Register
- RR[0:F] — QSM Receive Data RAM
- RSR — Reset Status Register
- SCCR[0:1] — SCI Control Registers [0:1]
- SCDR — SCI Data Register
- SCSR — SCI Status Register
- SIMCR — SIM Module Configuration Register
- SIMTR — System Integration Test Register
- SIMTRE — System Integration Test Register (ECLK)
- SPCR[0:3] — QSPI Control Registers [0:3]
- SPSR — QSPI Status Register
- SWSR — Software Watchdog Service Register
- SYNCR — Clock Synthesizer Control Register
- SYPCR — System Protection Control Register
- TCNT — Timer Counter Register
- TCTL[1:2] — Timer Control Registers [1:2]
- TFLG[1:2] — Timer Interrupt Flag Registers [1:2]
- TI4/O5 — Timer Input Capture 4/Output Compare 5 Register
- TIC[1:3] — Timer Input Capture Registers [1:3]
- TMSK[1:2] — Timer Interrupt Mask Register [1:2]
- TOC[1:4] — Timer Output Compare Registers [1:4]
- TR[0:F] — QSM Transmit Data RAM
- TSTMSRA — Test Module Master Shift Register A
- TSTMSRB — Test Module Master Shift Register B
- TSTRC — Test Module Repetition Count Register
- TSTSC — Test Module Shift Count Register

2.5 Conventions

Logic level one is the voltage that corresponds to a Boolean true (1) state.

Logic level zero is the voltage that corresponds to a Boolean false (0) state.

Set refers specifically to establishing logic level one on a bit or bits.

Clear refers specifically to establishing logic level zero on a bit or bits.

Asserted means that a signal is in active logic state. An active low signal changes from logic level one to logic level zero when asserted, and an active high signal changes from logic level zero to logic level one.

Negated means that an asserted signal changes logic state. An active low signal changes from logic level zero to logic level one when negated, and an active high signal changes from logic level one to logic level zero.

A specific mnemonic within a range is referred to by mnemonic and number. A15 is bit 15 of accumulator A; ADDR7 is line 7 of the address bus; CSOR0 is chip-select option register 0. **A range of mnemonics** is referred to by mnemonic and the numbers that define the range. AM[35:30] are bits 35 to 30 of accumulator M; CSOR[0:5] are the first six option registers.

Parentheses are used to indicate the content of a register or memory location, rather than the register or memory location itself. (A) is the content of accumulator A. (M : M + 1) is the content of the word at address M.

LSB means least significant bit or bits. **MSB** means most significant bit or bits. References to low and high bytes are spelled out.

LSW means least significant word or words. **MSW** means most significant word or words.

ADDR is the address bus. ADDR[7:0] are the eight LSB of the address bus.

DATA is the data bus. DATA[15:8] are the eight MSB of the data bus.



SECTION 3 OVERVIEW

This section contains information about the entire modular microcontroller. It lists the features of each module, shows device functional divisions and pin assignments, summarizes signal and pin functions, discusses the intermodule bus, and provides system memory maps. Timing and electrical specifications for the entire microcontroller and for individual modules are provided in **APPENDIX A ELECTRICAL CHARACTERISTICS**. Comprehensive module register descriptions and memory maps are provided in **APPENDIX D REGISTER SUMMARY**.

3.1 MCU Features

The following paragraphs highlight capabilities of each of the microcontroller modules. Each module is discussed separately in a subsequent section of this user's manual.

3.1.1 System Integration Module (SIM)

- External Bus Support
- Programmable Chip-Select Outputs
- System Protection Logic
- Watchdog Timer, Clock Monitor, and Bus Monitor
- System Protection Logic
- PLL System Clock for Low Power Operation
- Background Debugging Mode

3.1.2 Central Processing Unit (CPU32)

- Instruction Set Supports Controller Applications
- 32-Bit Architecture
- Virtual Memory Implementation
- Loop Mode of Instruction Execution
- Table Lookup and Interpolate Instruction
- Improved Exception Handling for Controller Applications
- Trace on Change of Flow
- Hardware Breakpoint Signal, Background Mode
- Fully Static Operation

3.1.3 Queued Serial Module (QSM)

- Serial Communication Interface (SCI), Enhanced Universal Asynchronous Receiver Transmitter (UART) with Modulus Baud Rate, Parity
- Queued Serial Peripheral Interface (SPI), High Speed Bidirectional Interface, 80-Byte RAM, Up to 16 Automatic Transfers
- Dual Function I/O Ports
- Continuous Cycling, 8 to 16 Bits per Transfer

3.1.4 General-Purpose Timer (GPT)

- Two 16-Bit Free-Running Counters With One Nine-Stage Prescaler
- Three Input Capture Channels
- Four Output Compare Channels
- One Input Capture/Output Compare Channel
- One Pulse Accumulator/Event Counter Input
- Two Pulse-Width Modulation Outputs
- Optional External Clock Input

3.2 System Block Diagram and Pin Assignment Diagrams

Figure 3-1 is a functional diagram of the MCU. Although diagram blocks represent the relative size of the physical modules, there is not a one-to-one correspondence between location and size of blocks in the diagram and location and size of integrated-circuit modules. **Figure 3-2** shows the pin assignments of the 132-pin plastic surface-mount package. **Figure 3-3** shows the pin assignments of the 144-pin plastic surface-mount package. Refer to **APPENDIX B MECHANICAL DATA AND ORDERING INFORMATION** for package dimensions. All pin functions and signal names are shown in this drawing. Refer to subsequent paragraphs in this section for pin and signal descriptions.

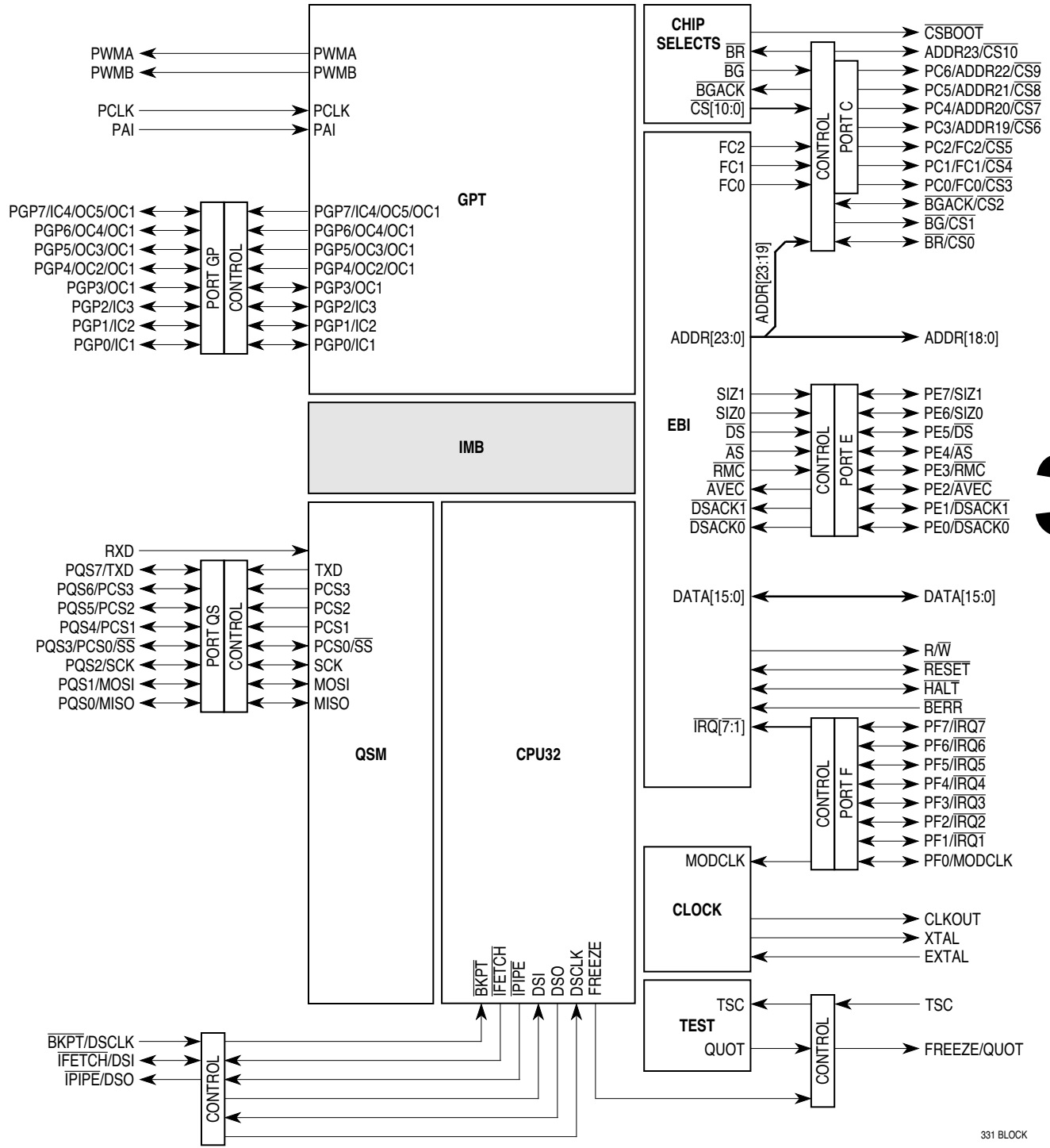

3

Figure 3-1 MCU Block Diagram

331 BLOCK

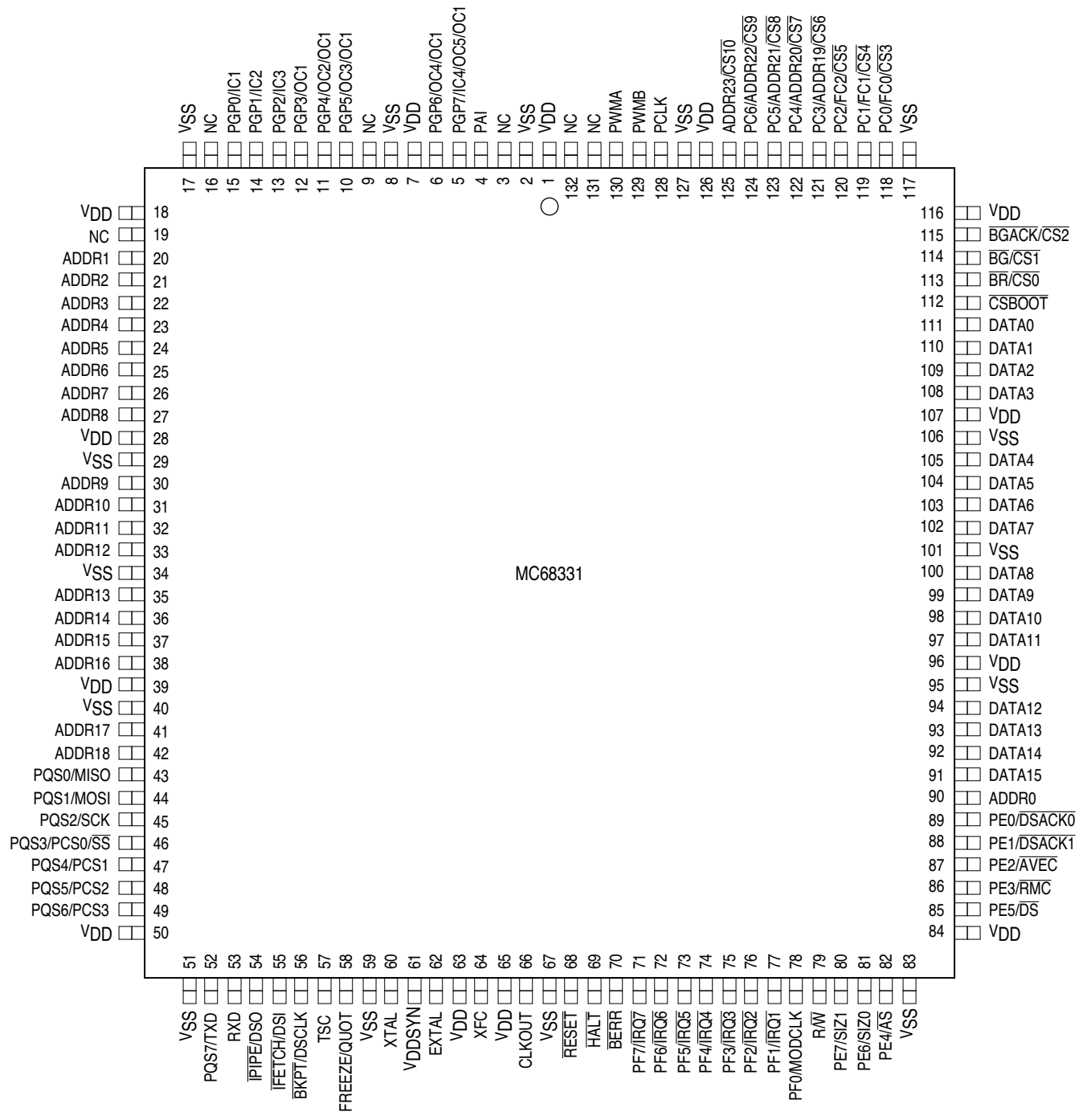

331 132-PIN QFP

Figure 3-2 Pin Assignments for 132-Pin Package

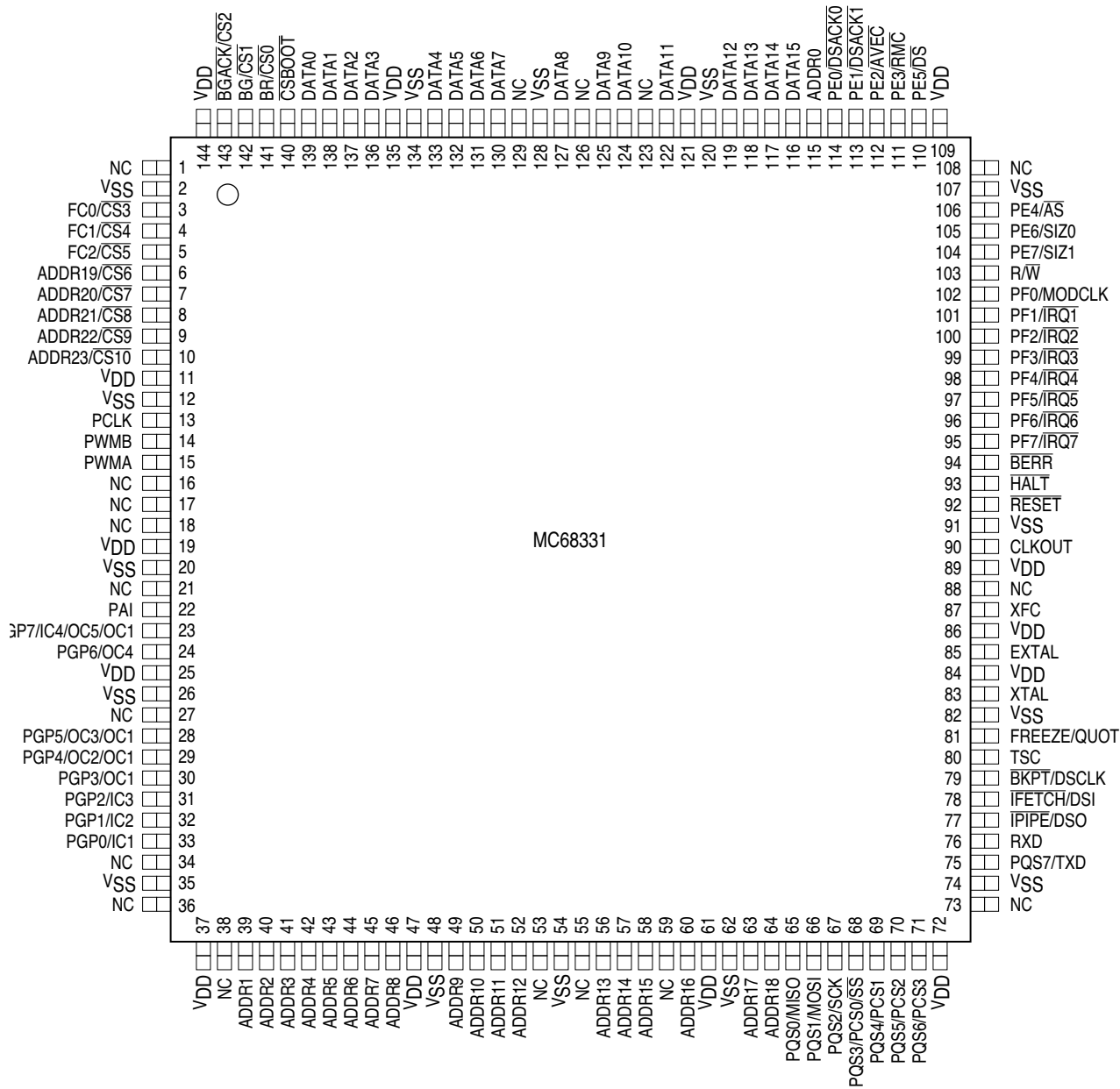

3

Figure 3-3 Pin Assignments for 144-Pin Package

3.3 Pin Descriptions

The following tables are a summary of the functional characteristics of MCU pins. **Table 3-1** shows types of output drivers. **Table 3-2** shows all inputs and outputs. Digital inputs and outputs use CMOS logic levels. An entry in the Discrete I/O column indicates that a pin can also be used for general-purpose input, output, or both. The I/O port designation is given when it applies. **Table 3-3** shows characteristics of power pins. Refer to **Figure 3-1** for port organization.

Table 3-1 MCU Driver Types

Type	I/O	Description
A	O	Output-only signals that are always driven; no external pull-up required
Aw	O	Type A output with weak P-channel pull-up during reset
B	O	Three-state output that includes circuitry to pull up output before high impedance is established, to ensure rapid rise time. An external holding resistor is required to maintain logic level while the pin is in the high-impedance state.
Bo	O	Type B output that can be operated in an open-drain mode

Table 3-2 MCU Pin Characteristics

Pin Mnemonic	Output Driver	Input Synchronized	Input Hysteresis	Discrete I/O	Port Designation
ADDR23/CS10/ECLK	A	Y	N	O	—
ADDR[22:19]/CS[9:6]	A	Y	N	O	PC[6:3]
ADDR[18:0]	A	Y	N	—	—
\overline{AS}	B	Y	N	I/O	PE5
\overline{AVEC}	B	Y	N	I/O	PE2
\overline{BERR}	B	Y	N	—	—
$\overline{BG/CS1}$	B	—	—	—	—
$\overline{BGACK/CS2}$	B	Y	N	—	—
$\overline{BKPT/DSCLK}$	—	Y	Y	—	—
$\overline{BR/CS0}$	B	Y	N	—	—
CLKOUT	A	—	—	—	—
\overline{CSBOOT}	B	—	—	—	—
DATA[15:0]1	Aw	Y	N	—	—
\overline{DS}	B	Y	N	I/O	PE4
$\overline{DSACK1}$	B	Y	N	I/O	PE1
$\overline{DSACK0}$	B	Y	N	I/O	PE0
DSI/IFETCH	A	Y	Y	—	—
DSO/IPIPE	A	—	—	—	—
EXTAL2	—	—	Special	—	—
FC[2:0]/CS[5:3]	A	Y	N	O	PC[2:0]
FREEZE/QUOT	A	—	—	—	—
IC4/OC5	A	Y	Y	I/O	GP4
IC[3:1]	A	Y	Y	I/O	GP[7:5]
\overline{HALT}	Bo	Y	N	—	—
$\overline{IRQ[7:1]}$	B	Y	Y	I/O	PF[7:1]
MISO	Bo	Y	Y	I/O	PQS0
MODCLK1	B	Y	N	I/O	PF0
MOSI	Bo	Y	Y	I/O	PQS1
OC[4:1]	A	Y	Y	I/O	GP[3:0]
PAI2	—	Y	Y	I	—
PCLK2	—	Y	Y	I	—
$\overline{PCSO/SS}$	Bo	Y	Y	I/O	PQS3
$\overline{PCS[3:1]}$	Bo	Y	Y	I/O	PQS[6:4]
PWMA, PWMB	A	—	—	O	—
R/W	A	Y	N	—	—
\overline{RESET}	Bo	Y	Y	—	—
\overline{RMC}	B	Y	N	I/O	PE3

Table 3-2 MCU Pin Characteristics (Continued)

Pin Mnemonic	Output Driver	Input Synchronized	Input Hysteresis	Discrete I/O	Port Designation
RXD	—	N	N	—	—
SCK	Bo	Y	Y	I/O	PQS2
SIZ[1:0]	B	Y	N	I/O	PE[7:6]
TSC	—	Y	Y	—	—
TXD	Bo	Y	Y	I/O	PQS7
XFC ³	—	—	—	Special	—
XTAL ³	—	—	—	Special	—

1. DATA[15:0] are synchronized during reset only. MODCLK is synchronized only when used as an input port pin.
2. EXTAL, XFC, and XTAL are clock reference connections.
3. PAI and PCLK can be used for discrete input, but are not part of an I/O port.

Table 3-3 MCU Power Connections

Pin Mnemonic	Description
VDDSYN	Clock Synthesizer Power
VSSE/VDDE	External Periphery Power (Source and Drain)
VSSI/VDDI	Internal Module Power (Source and Drain)

3.4 Signal Descriptions

The following tables define MCU signals. **Table 3-4** shows signal origin, type, and active state. **Table 3-5** describes signal functions. Both tables are sorted alphabetically by mnemonic. MCU pins often have multiple functions. More than one description can apply to a pin.

Table 3-4 Signal Characteristics

Signal Name	MCU Module	Signal Type	Active State
ADDR[23:0]	SIM	Bus	—
\overline{AS}	SIM	Output	0
\overline{AVEC}	SIM	Input	0
\overline{BERR}	SIM	Input	0
BG	SIM	Output	0
BGACK	SIM	Input	0
\overline{BKPT}	CPU32	Input	0
\overline{BR}	SIM	Input	0
CLKOUT	SIM	Output	—
$\overline{CS}[10:0]$	SIM	Output	0
\overline{CSBOOT}	SIM	Output	0
DATA[15:0]	SIM	Bus	—
\overline{DS}	SIM	Output	0
$\overline{DSACK}[1:0]$	SIM	Input	0
DSCLK	CPU32	Input	Serial Clock
DSI	CPU32	Input	(Serial Data)
DSO	CPU32	Output	(Serial Data)
EXTAL	SIM	Input	—

Table 3-4 Signal Characteristics (Continued)

Signal Name	MCU Module	Signal Type	Active State
FC[2:0]	SIM	Output	—
FREEZE	SIM	Output	1
HALT	SIM	Input/Output	0
IC[4:1]	GPT	Input	—
IFETCH	CPU32	Output	—
IPIPE	CPU32	Output	—
IRQ[7:1]	SIM	Input	0
MISO	QSM	Input/Output	—
MODCLK	SIM	Input	—
MOSI	QSM	Input/Output	—
OC[5:1]	GPT	Output	—
PAI	GPT	Input	—
PC[6:0]	SIM	Output	(Port)
PCS[3:0]	QSM	Input/Output	—
PE[7:0]	SIM	Input/Output	(Port)
PF[7:0]	SIM	Input/Output	(Port)
PGP[7:0]	GPT	Input/Output	(Port)
PQS[7:0]	QSM	Input/Output	(Port)
PCLK	GPT	Input	—
PWMA, PWMB	GPT	Output	—
QUOT	SIM	Output	—
RESET	SIM	Input/Output	0
RMC	SIM	Output	0
R/W	SIM	Output	1/0
RXD	QSM	Input	—
SCK	QSM	Input/Output	—
SIZ[1:0]	SIM	Output	—
SS	QSM	Input	0
TSC	SIM	Input	—
TXD	QSM	Output	—
XFC	SIM	Input	—
XTAL	SIM	Output	—

Table 3-5 Signal Function

Signal Name	Mnemonic	Function
Address Bus	ADDR[23:0]	24-bit address bus
Address Strobe	\overline{AS}	Indicates that a valid address is on the address bus
Autovector	\overline{AVEC}	Requests an automatic vector during interrupt acknowledge
Bus Error	\overline{BERR}	Indicates that a bus error has occurred
Bus Grant	\overline{BG}	Indicates that the MCU has relinquished the bus
Bus Grant Acknowledge	\overline{BGACK}	Indicates that an external device has assumed bus mastership
Breakpoint	\overline{BKPT}	Signals a hardware breakpoint to the CPU
Bus Request	\overline{BR}	Indicates that an external device requires bus mastership
System Clockout	CLKOUT	System clock output
Chip Selects	$\overline{CS}[10:0]$	Select external devices at programmed addresses
Boot Chip Select	\overline{CSBOOT}	Chip select for external boot start-up ROM
Data Bus	DATA[15:0]	16-bit data bus

Table 3-5 Signal Function (Continued)

Signal Name	Mnemonic	Function
Data Strobe	\overline{DS}	During a read cycle, indicates when it is possible for an external device to place data on the data bus. During a write cycle, indicates that valid data is on the data bus.
Data and Size Acknowledge	$\overline{DSACK}[1:0]$	Provide asynchronous data transfers and dynamic bus sizing
Development Serial In, Out, Clock	DSI, DSO, DSCLK	Serial I/O and clock for background debugging mode
Crystal Oscillator	EXTAL, XTAL	Connections for clock synthesizer circuit reference; a crystal or an external oscillator can be used
Function Codes	FC[2:0]	Identify processor state and current address space
Freeze	FREEZE	Indicates that the CPU has entered background mode
Halt	\overline{HALT}	Suspend external bus activity
Input Capture	IC[3:1]	When a specified transition is detected on an input capture pin, the value in an internal GPT counter is latched
Input Capture 4/ Output Compare 5	IC4/OC5	Can be configured for either an input capture or output compare
Instruction Pipeline	IPIPE, IFETCH	Indicate instruction pipeline activity
Interrupt Request Level	$\overline{IRQ}[7:1]$	Provides an interrupt priority level to the CPU
Master In Slave Out	MISO	Serial input to QSPI in master mode; serial output from QSPI in slave mode
Clock Mode Select	MODCLK	Selects the source and type of system clock
Master Out Slave In	MOSI	Serial output from QSPI in master mode; serial input to QSPI in slave mode
Output Compare	OC[5:1]	Change state when the value of an internal GPT counter matches a value stored in a GPT control register
Pulse Accumulator Input	PAI	Signal input to the pulse accumulator
Port C	PC[6:0]	SIM digital output port signals
Auxiliary Timer Clock Input	PCLK	External clock dedicated to the GPT
Peripheral Chip Select	PCS[3:0]	QSPI peripheral chip selects
Port E	PE[7:0]	SIM digital I/O port signals
Port F	PF[7:0]	SIM digital I/O port signals
Port GP	PGP[7:0]	GPT digital I/O port signals
Port QS	PQS[7:0]	QSM digital I/O port signals
Pulse-Width Modulation	PWMA, PWMB	Output for PWM
Quotient Out	QUOT	Provides the quotient bit of the polynomial divider
Reset	\overline{RESET}	System reset
Read-Modify-Write Cycle	\overline{RMC}	Indicates an indivisible read-modify-write instruction
Read/Write	R/W	Indicates the direction of data transfer on the bus
SCI Receive Data	RXD	Serial input to the SCI
QSPI Serial Clock	SCK	Clock output from QSPI in master mode; clock input to QSPI in slave mode
Size	SIZ[1:0]	Indicates the number of bytes to be transferred during a bus cycle
Slave Select	\overline{SS}	Causes serial transmission when QSPI is in slave mode; causes mode fault in master mode
Three-State Control	TSC	Places all output drivers in a high-impedance state
SCI Transmit Data	TXD	Serial output from the SCI
External Filter Capacitor	XFC	Connection for external phase-locked loop filter capacitor

3

3.5 Intermodule Bus

The intermodule bus (IMB) is a standardized bus developed to facilitate both design and operation of modular microcontrollers. It contains circuitry to support exception processing, address space partitioning, multiple interrupt levels, and vectored interrupts. The standardized modules in the MCU communicate with one another and with external components through the IMB. The IMB in the MCU uses 24 address and 16 data lines.

3.6 System Memory Map

Figure 3-4, **Figure 3-5**, **Figure 3-6**, **Figure 3-7**, and **Figure 3-8** are MCU memory maps. **Figure 3-4** shows IMB addresses of internal registers. **Figure 3-5** through **Figure 3-8** show system memory maps that use different external decoding schemes.

3.6.1 Internal Register Map

In **Figure 3-4**, IMB ADDR[23:20] are represented by the letter Y. The value represented by Y determines the base address of MCU module control registers. In M68300 microcontrollers, Y is equal to M111, where M is the logic state of the module mapping (MM) bit in the system integration module configuration register (SIMCR).

3.6.2 Address Space Maps

Figure 3-5 shows a single memory space. Function codes FC[2:0] are not decoded externally so that separate user/supervisor or program/data spaces are not provided. In **Figure 3-6**, FC2 is decoded, resulting in separate supervisor and user spaces. FC[1:0] are not decoded, so that separate program and data spaces are not provided. In **Figure 3-7** and **Figure 3-8**, FC[2:0] are decoded, resulting in four separate memory spaces: supervisor/program, supervisor/data, user/program and user/data.

All exception vectors are located in supervisor data space, except the reset vector, which is located in supervisor program space. Only the initial reset vector is fixed in the processor's memory map. Once initialization is complete, there are no fixed assignments. Since the vector base register (VBR) provides the base address of the vector table, the vector table can be located anywhere in memory. Refer to **SECTION 5 CENTRAL PROCESSING UNIT** for more information concerning memory management, extended addressing, and exception processing. Refer to **SECTION 4 SYSTEM INTEGRATION MODULE** for more information concerning function codes and address space types.

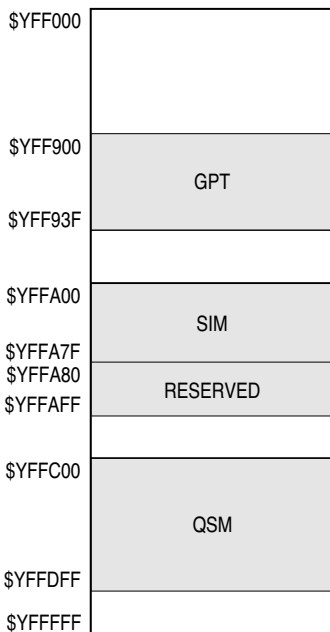

Y = M111, where M is the state of the module mapping (MM) bit in the SIM configuration register.

331 ADDRESS MAP

Figure 3-4 Internal Register Memory Map

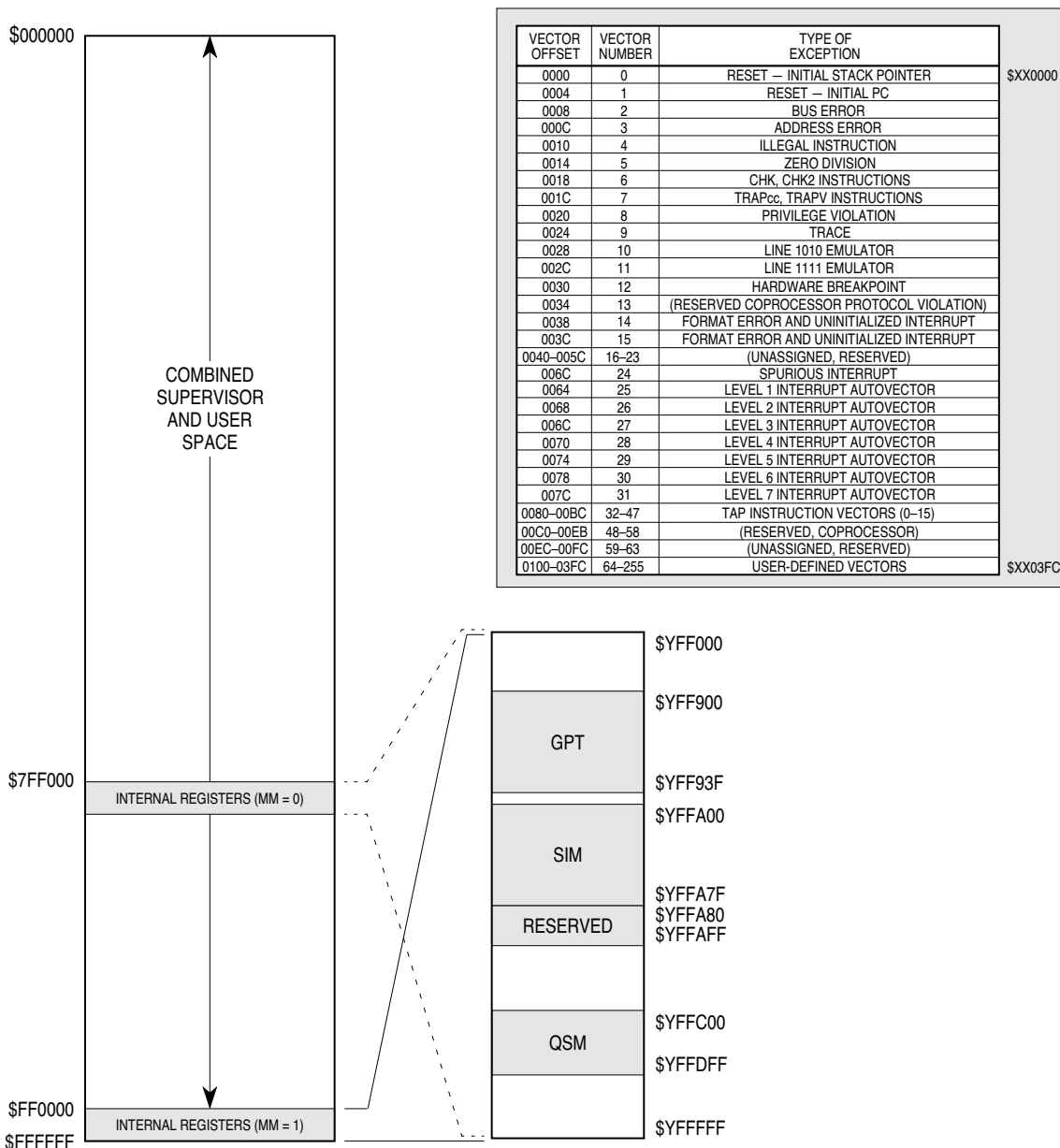

NOTES:

1. Location of the exception vector table is determined by the vector base register. The vector address is the sum of the vector base register and the vector offset.
2. Location of the module control registers is determined by the state of the module mapping (MM) bit in the SIM configuration register. Y = M111, where M is the state of the MM bit.
3. Unused addresses within the internal register block are mapped externally. "RESERVED" blocks are not mapped externally.

331 S/U COMB MAP

Figure 3-5 Overall Memory Map

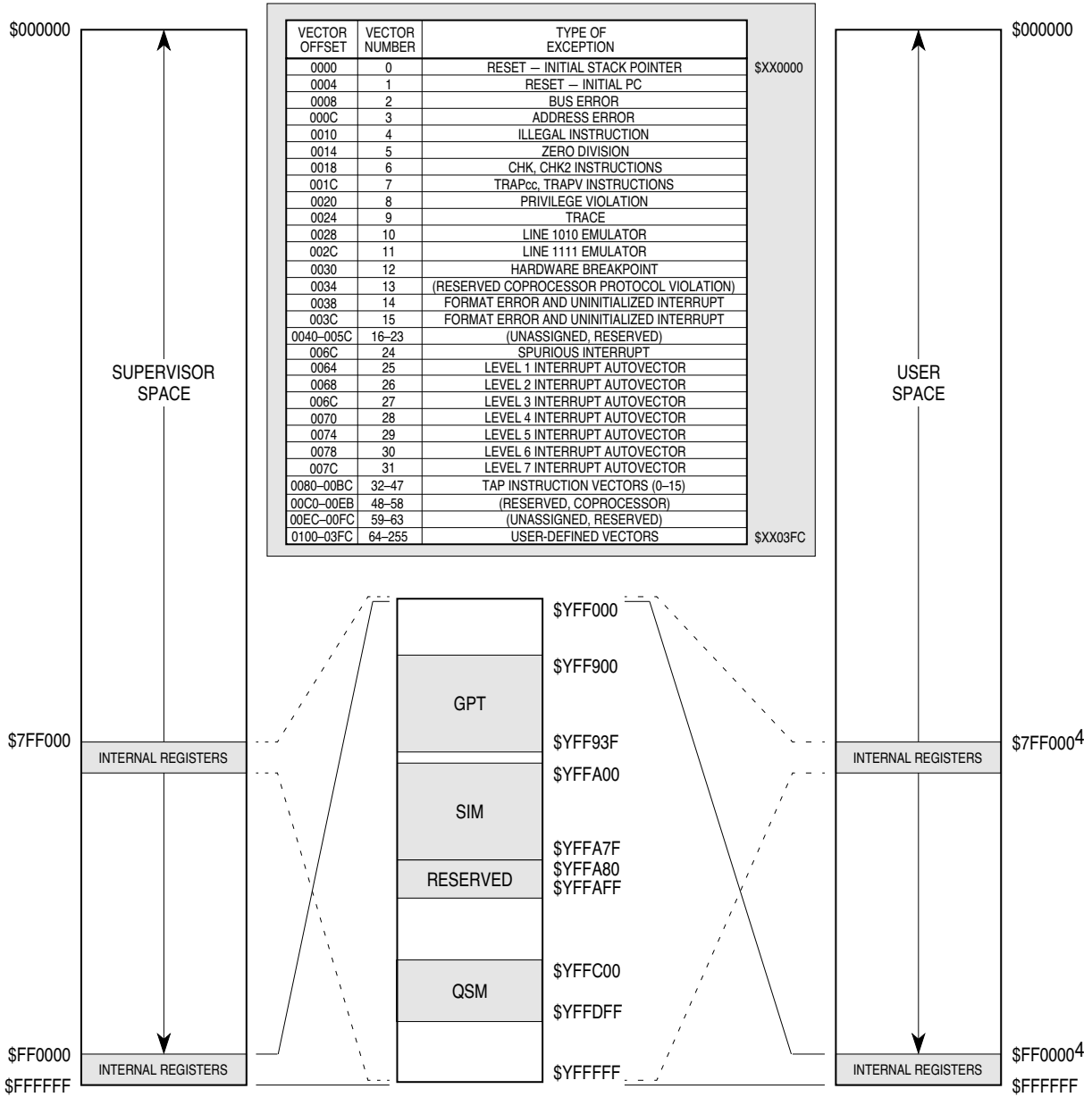

3

NOTES:

1. Location of the exception vector table is determined by the vector base register. The vector address is the sum of the vector base register and the vector offset.
2. Location of the module control registers is determined by the state of the module mapping (MM) bit in the SIM configuration register. Y = M111, where M is the state of the MM bit.
3. Unused addresses within the internal register block are mapped externally. "RESERVED" blocks are not mapped externally.
4. Some internal registers are not available in user space.

331 S/U SEP MAP

Figure 3-6 Separate Supervisor and User Space Map

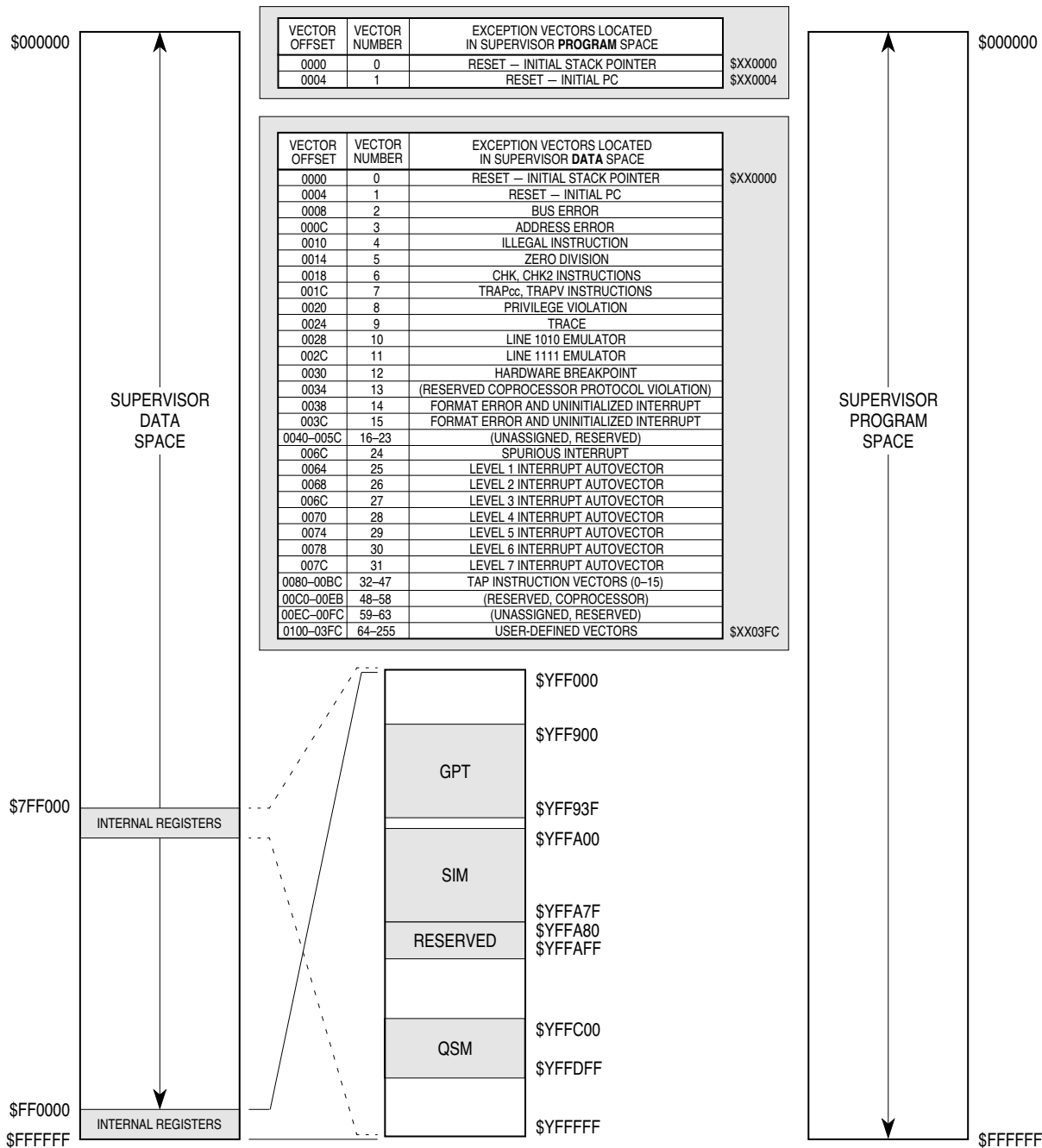

NOTES:

1. Location of the exception vector table is determined by the vector base register. The vector address is the sum of the vector base register and the vector offset.
2. Location of the module control registers is determined by the state of the module mapping (MM) bit in the SIM configuration register. Y = M111, where M is the state of the MM bit.
3. Unused addresses within the internal register block are mapped externally. "RESERVED" blocks are not mapped externally.
4. Some internal registers are not available in user space.

331 SUPER P/D MAP

Figure 3-7 Supervisor Space (Separate Program/Data Space) Map

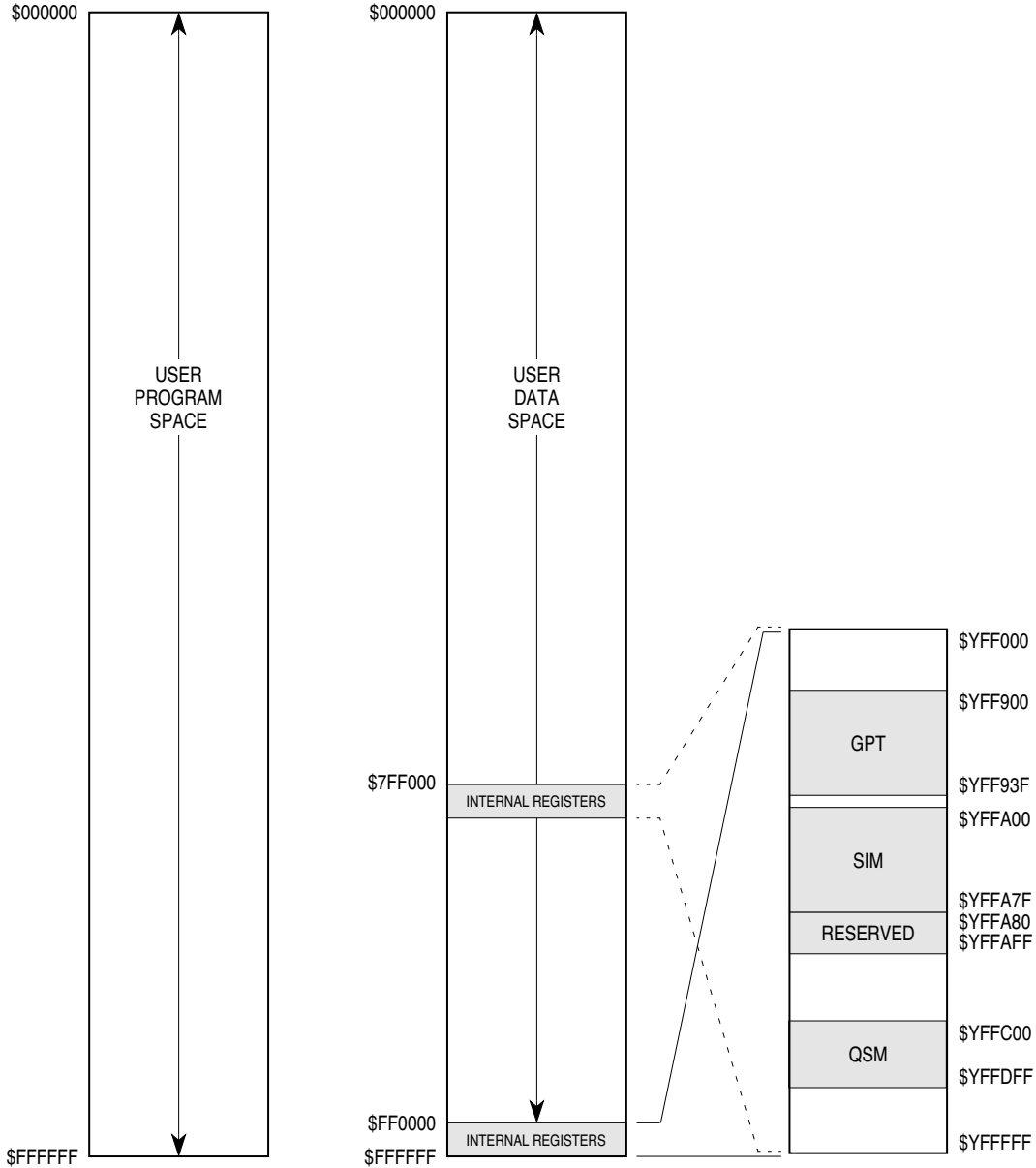

NOTES:

1. Location of the module control registers is determined by the state of the module mapping (MM) bit in the SIM configuration register. Y = M111, where M is the state of the MM bit.
2. Unused addresses within the internal register block are mapped externally. "RESERVED" blocks are not mapped externally.
3. Some internal registers are not available in user space.

331 USER P/D MAP

Figure 3-8 User Space (Separate Program/Data Space) Map

3.7 System Reset

The following information is a concise reference only. System reset is a complex operation. To understand operation during and after reset, refer to **SECTION 4 SYSTEM INTEGRATION MODULE**, paragraph **4.6 Reset** for a more complete discussion of the reset function.

3.7.1 SIM Reset Mode Selection

The logic states of certain data bus pins during reset determine SIM operating configuration. In addition, the state of the MODCLK pin determines system clock source and the state of the $\overline{\text{BKPT}}$ pin determines what happens during subsequent breakpoint assertions. **Table 3-6** is a summary of reset mode selection options.

Table 3-6 SIM Reset Mode Selection

Mode Select Pin	Default Function (Pin Left High)	Alternate Function (Pin Pulled Low)
DATA0	$\overline{\text{CSBOOT}}$ 16-Bit	$\overline{\text{CSBOOT}}$ 8-Bit
DATA1	$\overline{\text{CS0}}$ $\overline{\text{CS1}}$ $\overline{\text{CS2}}$	BRBG BGACK
DATA2	$\overline{\text{CS3}}$ $\overline{\text{CS4}}$ $\overline{\text{CS5}}$	FC0FC1FC2
DATA3 DATA4 DATA5 DATA6 DATA7	$\overline{\text{CS6}}$ $\overline{\text{CS}}[7:6]$ $\overline{\text{CS}}[8:6]$ $\overline{\text{CS}}[9:6]$ $\overline{\text{CS}}[10:6]$	ADDR19 ADDR[20:19] ADDR[21:19] ADDR[22:19] ADDR[23:19]
DATA8	$\overline{\text{DSACK0}}$, $\overline{\text{DSACK1}}$, AVEC, DS, AS, $\overline{\text{SIZ}}[1:0]$	PORTE
DATA9	$\overline{\text{IRQ}}[7:1]$, MODCLK	PORTF
DATA11	Test Mode Disabled	Test Mode Enabled
MODCLK	VCO = System Clock	EXTAL = System Clock
$\overline{\text{BKPT}}$	Background Mode Disabled	Background Mode Enabled

3.7.2 MCU Module Pin Function During Reset

Generally, pins associated with modules other than the SIM default to port functions, and input/output ports are set to input state. This is accomplished by disabling pin functions in the appropriate control registers, and by clearing the appropriate port data direction registers. Refer to individual module sections in this manual for more information. **Table 3-7** is a summary of module pin function out of reset.

Table 3-7 Module Pin Functions

Module	Pin Mnemonic	Function
CPU32	DSI/ $\overline{\text{IFETCH}}$	DSI/ $\overline{\text{IFETCH}}$
	DSO/ $\overline{\text{IPIPE}}$	DSO/ $\overline{\text{IPIPE}}$
	BKPT/DSCLK	BKPT/DSCLK
GPT	PGP7/IC4/OC5	Discrete Input
	PGP[6:3]/OC[4:1]	Discrete Input
	PGP[2:0]/IC[3:1]	Discrete Input
	PAI	Discrete Input
	PCLK	Discrete Input
	PWMA, PWMB	Discrete Output
QSM	PQS7/TXD	Discrete Input
	PQS[6:4]/PCS[3:1]	Discrete Input
	PQS3/PCS0/ $\overline{\text{SS}}$	Discrete Input
	PQS2/SCK	Discrete Input
	PQS1/MOSI	Discrete Input
	PQS0/MISO	Discrete Input
	RXD	RXD



SECTION 4 SYSTEM INTEGRATION MODULE

This section is an overview of SIM function. Refer to the *SIM Reference Manual* (SIM-RM/AD) for a comprehensive discussion of SIM capabilities. Refer to **APPENDIX D REGISTER SUMMARY** for information concerning the SIM address map and register structure.

4.1 General

The system integration module (SIM) consists of five functional blocks. **Figure 4-1** is a block diagram of the SIM.

The system configuration and protection block controls configuration parameters and provides bus and software watchdog monitors. In addition, it provides a periodic interrupt generator to support execution of time-critical control routines.

The system clock generates clock signals used by the SIM, other IMB modules, and external devices.

The external bus interface handles the transfer of information between IMB modules and external address space. EBI pins can also be configured for use as general-purpose I/O ports E and F.

The chip-select block provides 12 chip-select signals. Each chip-select signal has an associated base register and option register that contain the programmable characteristics of that chip select. Chip-select pins can also be configured for use as general-purpose output port C.

The system test block incorporates hardware necessary for testing the MCU. It is used to perform factory tests, and its use in normal applications is not supported.

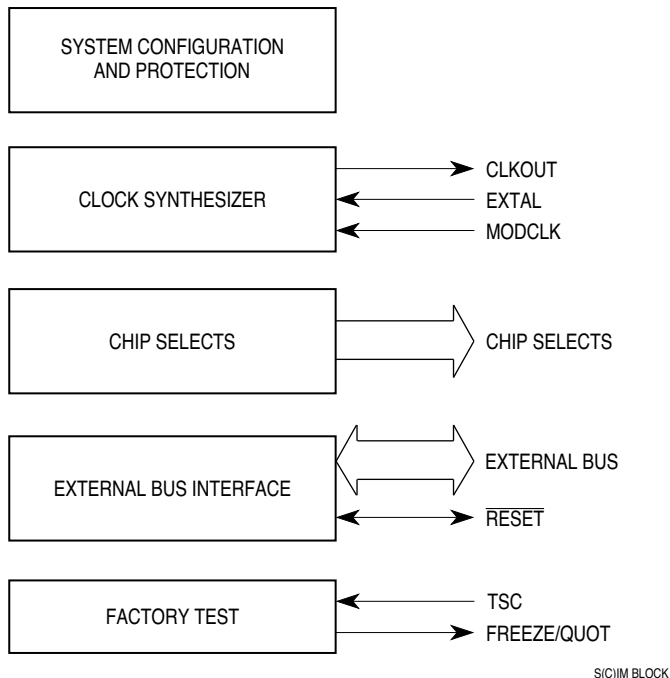

Figure 4-1 System Integration Module Block Diagram

4.2 System Configuration and Protection

The system configuration and protection functional block controls module configuration, preserves reset status, monitors internal activity, and provides periodic interrupt generation. **Figure 4-2** is a block diagram of the submodule.

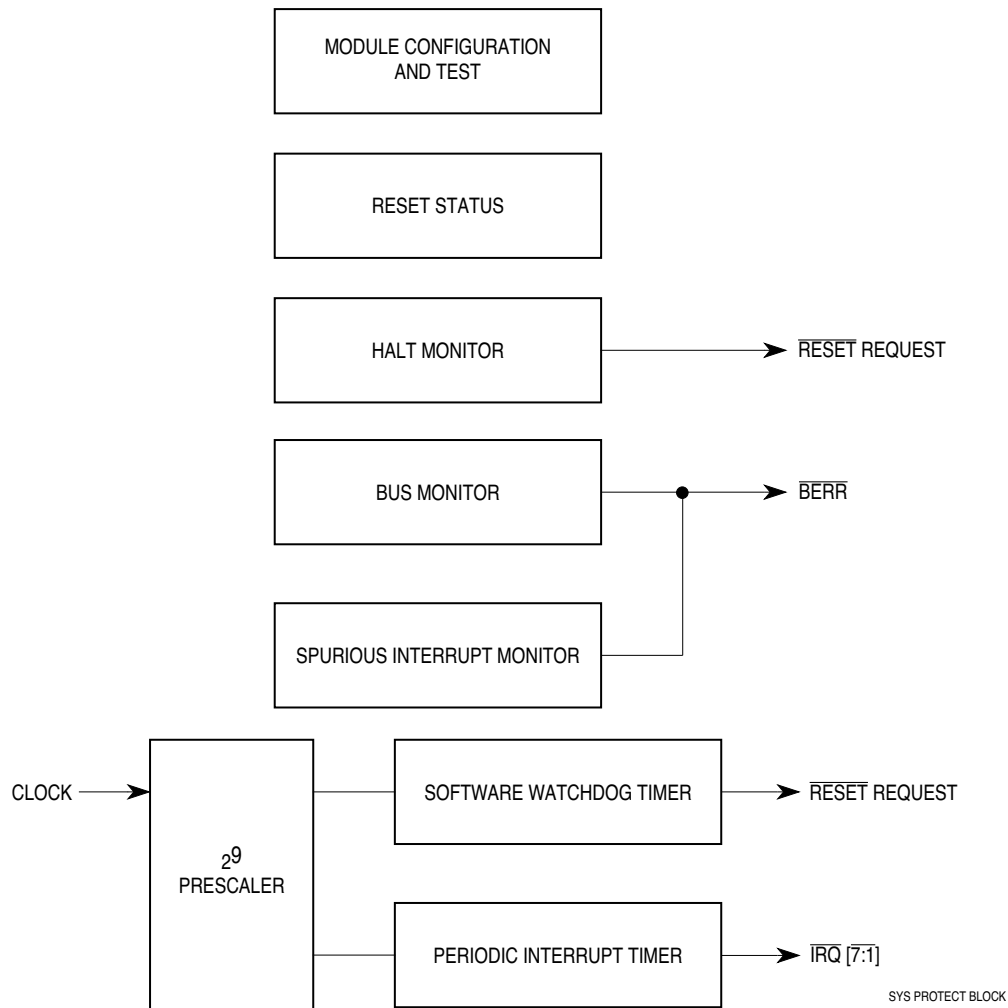

Figure 4-2 System Configuration and Protection

4.2.1 Module Mapping

Control registers for all the modules in the microcontroller are mapped into a 4-Kbyte block. The state of the module mapping bit (MM) in the SIM module configuration register (SIMCR) determines where the control register block is located in the system memory map. When MM = 0, register addresses range from \$7FF000 to \$7FFFFFF; when MM = 1, register addresses range from \$FFF000 to \$FFFFFF.

4.2.2 Interrupt Arbitration

Each module that can generate interrupt requests has an interrupt arbitration (IARB) field. Arbitration between interrupt requests of the same priority is performed by serial contention between IARB field bit values. Contention must take place whenever an interrupt request is acknowledged, even when there is only a single request pending. For an interrupt to be serviced, the appropriate IARB field must have a non-zero value. If an interrupt request from a module with an IARB field value of %0000 is recognized, the CPU32 processes a spurious interrupt exception.

Because the SIM routes external interrupt requests to the CPU32, the SIM IARB field value is used for arbitration between internal and external interrupts of the same priority. The reset value of IARB for the SIM is %1111, and the reset IARB value for all other modules is %0000, which prevents SIM interrupts from being discarded during initialization. Refer to **4.7 Interrupts** for a discussion of interrupt arbitration.

4.2.3 Show Internal Cycles

A show cycle allows internal bus transfers to be monitored externally. The SHEN field in the SIMCR determines what the external bus interface does during internal transfer operations. **Table 4-1** shows whether data is driven externally, and whether external bus arbitration can occur. Refer to **4.5.6.2 Show Cycles** for more information.

Table 4-1 Show Cycle Enable Bits

SHEN	Action
00	Show cycles disabled, external arbitration enabled
01	Show cycles enabled, external arbitration disabled
10	Show cycles enabled, external arbitration enabled
11	Show cycles enabled, external arbitration enabled; internal activity is halted by a bus grant

4.2.4 Factory Test Mode

The internal IMB can serve as slave to an external master for direct module testing. This test mode is reserved for factory test. Slave mode is enabled by holding DATA11 low during reset. The slave enabled (SLVEN) bit is a read-only bit that shows the reset state of DATA11.

4.2.5 Register Access

The CPU32 can operate at either of two privilege levels. Supervisor level is more privileged than user level — all instructions and system resources are available at supervisor level, but access is restricted at user level. Effective use of privilege level can protect system resources from uncontrolled access. The state of the S bit in the CPU status register determines access level, and whether the user or supervisor stack pointer is used for stacking operations. The SUPV bit places SIM global registers in either supervisor or user data space. When SUPV = 0, registers with controlled access are accessible from either the user or supervisor privilege level; when SUPV = 1, registers with controlled access are restricted to supervisor access only.

4.2.6 Reset Status

The reset status register (RSR) latches internal MCU status during reset. Refer to **4.6.9 Reset Status Register** for more information.

4.2.7 Bus Monitor

The internal bus monitor checks data and size acknowledge (\overline{DSACK}) or autovector (\overline{AVEC}) signal response times during normal bus cycles. The monitor asserts the internal bus error (\overline{BERR}) signal when the response time is excessively long.

\overline{DSACK} and \overline{AVEC} response times are measured in clock cycles. Maximum allowable response time can be selected by setting the bus monitor timing (BMT) field in the system protection control register (SYPCR). **Table 4-2** shows the periods allowed.

Table 4-2 Bus Monitor Period

BMT	Bus Monitor Time-Out Period
00	64 System Clocks
01	32 System Clocks
10	16 System Clocks
11	8 System Clocks

The monitor does not check \overline{DSACK} response on the external bus unless the CPU32 initiates a bus cycle. The BME bit in SYPCR enables the internal bus monitor for internal to external bus cycles. If a system contains external bus masters, an external bus monitor must be implemented and the internal-to-external bus monitor option must be disabled.

When monitoring transfers to an 8-bit port, the bus monitor does not reset until both byte accesses of a word transfer are completed. Monitor time-out period must be at least twice the number of clocks that a single byte access requires.

4.2.8 Halt Monitor

The halt monitor responds to an assertion of the \overline{HALT} signal on the internal bus. Refer to **4.5.5.2 Double Bus Faults** for more information. Halt monitor reset can be inhibited by the halt monitor (HME) bit in SYPCR.

4.2.9 Spurious Interrupt Monitor

During interrupt exception processing, the CPU32 normally acknowledges an interrupt request, recognizes the highest priority source, and then acquires a vector or responds to a request for autovectoring. The spurious interrupt monitor asserts the internal bus error signal (\overline{BERR}) if no interrupt arbitration occurs during interrupt exception processing. The assertion of \overline{BERR} causes the CPU32 to load the spurious interrupt exception vector into the program counter. The spurious interrupt monitor cannot be disabled. Refer to **4.7 Interrupts** for further information. For detailed information about interrupt exception processing, refer to **SECTION 5 CENTRAL PROCESSING UNIT**.

4.2.10 Software Watchdog

The software watchdog is controlled by the software watchdog enable (SWE) bit in SYPCR. When enabled, the watchdog requires that a service sequence be written to software service register SWSR on a periodic basis. If servicing does not take place, the watchdog times out and asserts the reset signal.

Perform a software watchdog service sequence as follows:

1. Write \$55 to SWSR.
2. Write \$AA to SWSR.

Both writes must occur before time-out in the order listed, but any number of instructions can be executed between the two writes.

Watchdog clock rate is affected by the software watchdog prescale (SWP) and software watchdog timing (SWT) fields in SYPCR.

SWP determines system clock prescaling for the watchdog timer and determines that one of two options, either no prescaling or prescaling by a factor of 512, can be selected. The value of SWP is affected by the state of the MODCLK pin during reset, as shown in **Table 4-3**. System software can change SWP value.

Table 4-3 MODCLK Pin and SWP Bit During Reset

MODCLK	SWP
0 (External Clock)	1 (÷ 512)
1 (Internal Clock)	0 (÷ 1)

The SWT field selects the divide ratio used to establish software watchdog time-out period. Time-out period is given by the following equations.

$$\text{Time-out Period} = \frac{1}{\text{EXTAL Frequency} / \text{Divide Ratio}}$$

or

$$\text{Time-out Period} = \frac{\text{Divide Ratio}}{\text{EXTAL Frequency}}$$

Table 4-4 shows the ratio for each combination of SWP and SWT bits. When SWT[1:0] are modified, a watchdog service sequence must be performed before the new time-out period can take effect.

Table 4-4 Software Watchdog Ratio

SWP	SWT	Ratio
0	00	2 ⁹
0	01	2 ¹¹
0	10	2 ¹³
0	11	2 ¹⁵
1	00	2 ¹⁸
1	01	2 ²⁰
1	10	2 ²²
1	11	2 ²⁴

Figure 4-3 is a block diagram of the watchdog timer and the clock control for the periodic interrupt timer.

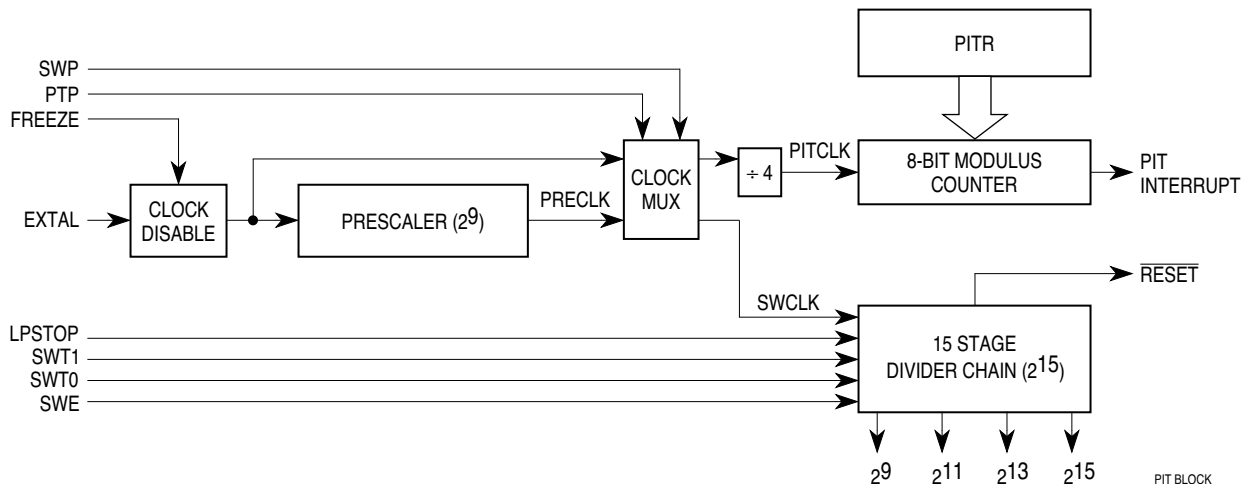

Figure 4-3 Periodic Interrupt Timer and Software Watchdog Timer

4.2.11 Periodic Interrupt Timer

The periodic interrupt timer allows the generation of interrupts of specific priority at pre-determined intervals. This capability is often used to schedule control system tasks that must be performed within time constraints. The timer consists of a prescaler, a modulus counter, and registers that determine interrupt timing, priority and vector assignment. Refer to **SECTION 5 CENTRAL PROCESSING UNIT** for further information about interrupt exception processing.

The periodic interrupt modulus counter is clocked by a signal derived from the buffered crystal oscillator (EXTAL) input pin unless an external frequency source is used. The value of the periodic timer prescaler (PTP) bit in the periodic interrupt timer register (PITR) determines system clock prescaling for the watchdog timer. One of two options, either no prescaling, or prescaling by a factor of 512, can be selected. The value of PTP is affected by the state of the MODCLK pin during reset, as shown in **Table 4-5**. System software can change PTP value.

Table 4-5 MODCLK Pin and PTP Bit at Reset

MODCLK	PTP
0 (External Clock)	1 ($\div 512$)
1 (Internal Clock)	0 ($\div 1$)

Either clock signal (EXTAL or $EXTAL \div 512$) is divided by four before driving the modulus counter (PITCLK). The modulus counter is initialized by writing a value to the periodic timer modulus timer modulus (PITM) field in the PITR. A zero value turns off the periodic timer. When the modulus counter value reaches zero, an interrupt is generated. The modulus counter is then reloaded with the value in PITM and counting repeats. If a new value is written to PITR, it is loaded into the modulus counter when the current count is completed.

Use the following expression to calculate timer period.

$$\text{PIT Period} = \frac{(\text{PIT Modulus})(\text{Prescaler Value})(4)}{\text{EXTAL Frequency}}$$

Interrupt priority and vectoring are determined by the values of the periodic interrupt request level (PIRQL) and periodic interrupt vector (PIV) fields in the periodic interrupt control register (PICR).

Content of PIRQL is compared to the CPU32 interrupt priority mask to determine whether the interrupt is recognized. **Table 4-6** shows priority of PIRQL values. Because of SIM hardware prioritization, a PIT interrupt is serviced before an external interrupt request of the same priority. The periodic timer continues to run when the interrupt is disabled.

Table 4-6 Periodic Interrupt Priority

PIRQL	Priority Level
000	Periodic Interrupt Disabled
001	Interrupt Priority Level 1
010	Interrupt Priority Level 2
011	Interrupt Priority Level 3
100	Interrupt Priority Level 4
101	Interrupt Priority Level 5
110	Interrupt Priority Level 6
111	Interrupt Priority Level 7

The PIV field contains the periodic interrupt vector. The vector is placed on the IMB when an interrupt request is made. The vector number used to calculate the address of the appropriate exception vector in the exception vector table. Reset value of the PIV field is \$0F, which corresponds to the uninitialized interrupt exception vector.

4.2.12 Low-Power STOP Operation

When the CPU32 executes the LPSTOP instruction, the current interrupt priority mask is stored in the clock control logic, internal clocks are disabled according to the state of the STSIM bit in the SIMCR, and the MCU enters low-power stop mode. The bus monitor, halt monitor, and spurious interrupt monitor are all inactive during low-power stop.

During low-power stop, the clock input to the software watchdog timer is disabled and the timer stops. The software watchdog begins to run again on the first rising clock edge after low-power stop ends. The watchdog is not reset by low-power stop. A service sequence must be performed to reset the timer.

The periodic interrupt timer does not respond to the LPSTOP instruction, but continues to run during LPSTOP. To stop the periodic interrupt timer, PITR must be loaded with a zero value before the LPSTOP instruction is executed. A PIT interrupt, or an external interrupt request, can bring the MCU out of the low-power stop condition if it has a higher priority than the interrupt mask value stored in the clock control logic when low-power stop is initiated. LPSTOP can be terminated by a reset.

4.2.13 Freeze Operation

The FREEZE signal halts MCU operations during debugging. FREEZE is asserted internally by the CPU32 if a breakpoint occurs while background mode is enabled. When FREEZE is asserted, only the bus monitor, software watchdog, and periodic interrupt timer are affected. The halt monitor and spurious interrupt monitor continue to operate normally. Setting the freeze bus monitor (FRZBM) bit in the SIMCR disables the bus monitor when FREEZE is asserted, and setting the freeze software watchdog (FRZSW) bit disables the software watchdog and the periodic interrupt timer when FREEZE is asserted. When FRZSW is set, FREEZE assertion must be at least two times the PIT clock source period to ensure an accurate number of PIT counts.

4.3 System Clock

The system clock in the SIM provides timing signals for the IMB modules and for an external peripheral bus. Because the MCU is a fully static design, register and memory contents are not affected when the clock rate changes. System hardware and software support changes in clock rate during operation.

The system clock signal can be generated in one of three ways. An internal phase-locked loop can synthesize the clock from either an internal reference or an external reference, or the clock signal can be input from an external frequency source. Keep these clock sources in mind while reading the rest of this section. **Figure 4-4** is a block diagram of the system clock. Refer to **APPENDIX A ELECTRICAL CHARACTERISTICS** for clock specifications.

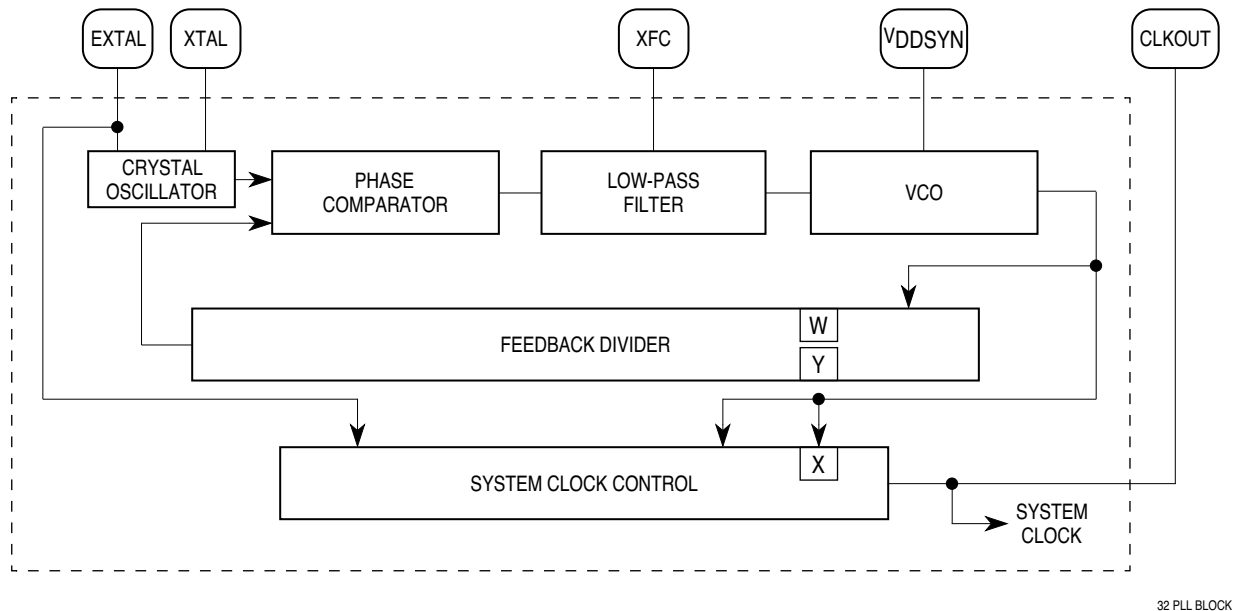

32 PLL BLOCK

Figure 4-4 System Clock Block Diagram

4.3.1 Clock Sources

The state of the clock mode (MODCLK) pin during reset determines clock source. When MODCLK is held high during reset, the clock synthesizer generates a clock signal from either an internal or an external reference frequency — the clock synthesizer control register (SYNCR) determines operating frequency and mode of operation. When MODCLK is held low during reset, the clock synthesizer is disabled and an external system clock signal must be applied — SYNCR control bits have no effect.

To generate a reference frequency using the internal oscillator a reference crystal must be connected between the XTAL and XTAL pins. **Figure 4-5** shows a recommended circuit.

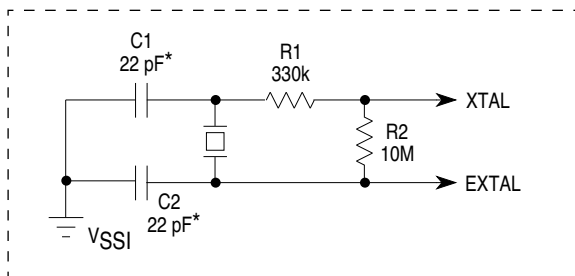

* Resistance and capacitance based on a test circuit constructed with a DAISHINKU DMX-38 32.768-kHz crystal. Specific components must be based on crystal type. Contact crystal vendor for exact circuit.

32 OSCILLATOR

Figure 4-5 System Clock Oscillator Circuit

If an external reference signal or an external system clock signal is applied via the EXTAL pin, the XTAL pin must be left floating. External reference signal frequency must be less than or equal to maximum specified reference frequency. External system clock signal frequency must be less than or equal to maximum specified system clock frequency.

When an external system clock signal is applied (PLL disabled, MODCLK = 0 during reset), the duty cycle of the input is critical, especially at operating frequencies close to maximum. The relationship between clock signal duty cycle and clock signal period is expressed:

$$\text{Minimum External Clock Period} = \frac{\text{Minimum External Clock High/Low Time}}{50\% - \text{Percentage Variation of External Clock Input Duty Cycle}}$$

4.3.2 Clock Synthesizer Operation

V_{DDSYN} is used to power the clock circuits when either an internal or an external reference frequency is applied. A separate power source increases MCU noise immunity and can be used to run the clock when the MCU is powered down. A quiet power supply must be used as the V_{DDSYN} source. Adequate external bypass capacitors should be placed as close as possible to the V_{DDSYN} pin to assure stable operating frequen-

cy. When an external system clock signal is applied and the PLL is disabled, V_{DDSYN} should be connected to the V_{DD} supply. Refer to the *SIM Reference Manual (SIMRM/AD)* for more information regarding system clock power supply conditioning.

A voltage controlled oscillator (VCO) generates the system clock signal. To maintain a 50% clock duty cycle, VCO frequency is either two or four times system clock frequency, depending on the state of the X bit in SYNCR. A portion of the clock signal is fed back to a divider/counter. The divider controls the frequency of one input to a phase comparator. The other phase comparator input is a reference signal, either from the crystal oscillator or from an external source. The comparator generates a control signal proportional to the difference in phase between the two inputs. The signal is low-pass filtered and used to correct VCO output frequency.

Filter geometry can vary, depending upon the external environment and required clock stability. **Figure 4-6** shows two recommended filters. XFC pin leakage must be as specified in **APPENDIX A ELECTRICAL CHARACTERISTICS** to maintain optimum stability and PLL performance.

An external filter network connected to the XFC pin is not required when an external system clock signal is applied and the PLL is disabled. The XFC pin must be left floating in this case.

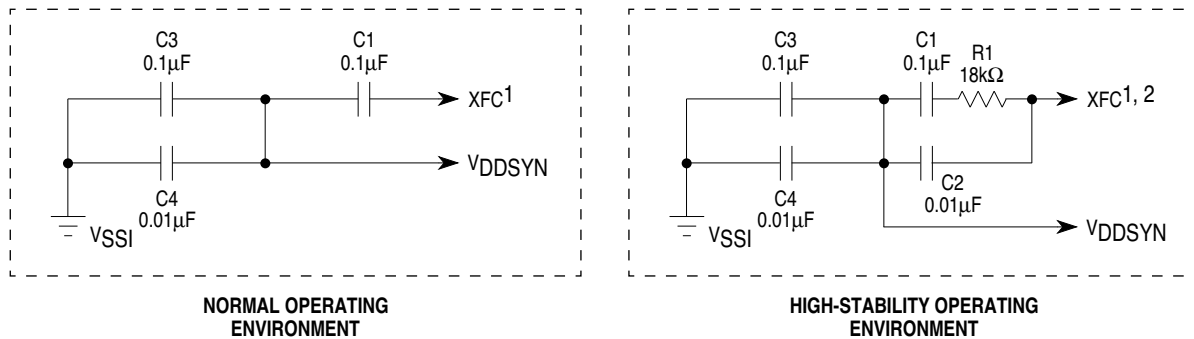

1. Maintain low-leakage on the XFC node. See Appendix A electrical characteristics for more information.
2. Recommended loop filter for reduced sensitivity to low-frequency noise.

16/32 XFC CONN

Figure 4-6 System Clock Filter Networks

The synthesizer locks when VCO frequency is equal to EXTAL frequency. Lock time is affected by the filter time constant and by the amount of difference between the two comparator inputs. Whenever comparator input changes, the synthesizer must relock. Lock status is shown by the SLOCK bit in SYNCR. During power-up, the MCU does not come out of reset state until the synthesizer locks. Crystal type, characteristic frequency, and layout of external oscillator circuitry affect lock time.

When the clock synthesizer is used, control register SYNCR determines operating frequency and various modes of operation. The SYNCR W bit controls a three-bit prescaler in the feedback divider. Setting W increases VCO speed by a factor of four. The

SYNCR Y field determines the count modulus for a modulo 64 down counter, causing it to divide by a value of Y + 1. When W or Y values change, VCO frequency changes, and there is a VCO relock delay. The SYNCR X bit controls a divide-by-two circuit that is not in the synthesizer feedback loop. When X = 0 (reset state), the divider is enabled, and system clock frequency is one-fourth VCO frequency; setting X disables the divider, doubling clock speed without changing VCO speed. There is no relock delay when clock speed is changed by the X bit.

Clock frequency is determined by SYNCR bit settings as follows:

$$F_{\text{SYSTEM}} = F_{\text{REFERENCE}} [4(Y + 1)(2^{2W+X})]$$

The reset state of SYNCR (\$3F00) produces a modulus-64 count.

For the device to perform correctly, system clock and VCO frequencies selected by the W, X, and Y bits must be within the limits specified for the MCU. Do not use a combination of bit values that selects either an operating frequency or a VCO frequency greater than the maximum specified values in **APPENDIX A ELECTRICAL CHARACTERISTICS**.

Table 4-7 shows clock control multipliers for all possible combinations of SYNCR bits. **Table 4-8** shows clock frequencies available with a 32.768-kHz reference and a maximum specified clock frequency of 20.97 MHz.

Table 4-7 Clock Control Multipliers

To obtain clock frequency in kilohertz, find counter modulus in the left column, then multiply reference frequency by value in appropriate prescaler cell.

Modulus Y	Prescalers			
	[W:X] = 00	[W:X] = 01	[W:X] = 10	[W:X] = 11
000000	4	8	16	32
000001	8	16	32	64
000010	12	24	48	96
011111	16	32	64	128
000011	20	40	80	160
000100	24	48	96	192
000101	28	56	112	224
000110	32	64	128	256
000111	36	72	144	288
001000	40	80	160	320
001001	44	88	176	352
001010	48	96	192	384
001011	52	104	208	416
001100	56	112	224	448
001101	60	120	240	480
001110	64	128	256	512
001111	68	136	272	544
010000	72	144	288	576
010001	76	152	304	608
010010	80	160	320	640
010011	84	168	336	672

Table 4-7 Clock Control Multipliers (Continued)

To obtain clock frequency in kilohertz, find counter modulus in the left column, then multiply reference frequency by value in appropriate prescaler cell.

Modulus Y	Prescalers			
	[W:X] = 00	[W:X] = 01	[W:X] = 10	[W:X] = 11
010100	88	176	352	704
010101	92	184	368	736
010110	96	192	384	768
010111	100	200	400	800
011000	104	208	416	832
011001	108	216	432	864
011010	112	224	448	896
011011	116	232	464	928
011100	120	240	480	960
011101	124	248	496	992
011110	128	256	512	1024
100000	132	264	528	1056
100001	136	272	544	1088
100010	140	280	560	1120
100011	144	288	576	1152
100100	148	296	592	1184
100101	152	304	608	1216
100110	156	312	624	1248
100111	160	320	640	1280
101000	164	328	656	1312
101001	168	336	672	1344
101010	172	344	688	1376
101011	176	352	704	1408
101100	180	360	720	1440
101101	184	368	736	1472
101110	188	376	752	1504
101111	192	384	768	1536
110000	196	392	784	1568
110001	200	400	800	1600
110010	204	408	816	1632
110011	208	416	832	1664
110100	212	424	848	1696
110101	216	432	864	1728
110110	220	440	880	1760
110111	224	448	896	1792
111000	228	456	912	1824
111001	232	464	928	1856
111010	236	472	944	1888
111011	240	480	960	1920
111100	244	488	976	1952
111101	248	496	992	1984
111110	252	504	1008	2016
111111	256	512	1024	2048

Table 4-8 System Frequencies from 32.768-kHz Reference

To obtain clock frequency in kilohertz, find counter modulus in the left column, then look in appropriate prescaler cell. Shaded cells contain values that exceed specified maximum system frequency.

Modulus Y	Prescaler			
	[W:X] = 00	[W:X] = 01	[W:X] = 10	[W:X] = 11
000000	131	262	524	1049
000001	262	524	1049	2097
000010	393	786	1573	3146
000011	524	1049	2097	4194
000100	655	1311	2621	5243
000101	786	1573	3146	6291
000110	918	1835	3670	7340
000111	1049	2097	4194	8389
001000	1180	2359	4719	9437
001001	1311	2621	5243	10486
001010	1442	2884	5767	11534
001011	1573	3146	6291	12583
001100	1704	3408	6816	13631
001101	1835	3670	7340	14680
001110	1966	3932	7864	15729
001111	2097	4194	8389	16777
010000	2228	4456	8913	17826
010001	2359	4719	9437	18874
010010	2490	4981	9961	19923
010011	2621	5243	10486	20972
010100	2753	5505	11010	22020
010101	2884	5767	11534	23069
010110	3015	6029	12059	24117
010111	3146	6291	12583	25166
011000	3277	6554	13107	26214
011001	3408	6816	13631	27263
011010	3539	7078	14156	28312
011011	3670	7340	14680	29360
011100	3801	7602	15204	30409
011101	3932	7864	15729	31457
011110	4063	8126	16253	32506
011111	4194	8389	16777	33554
100000	4325	8651	17302	34603
100001	4456	8913	17826	35652
100010	4588	9175	18350	36700
100011	4719	9437	18874	37749
100100	4850	9699	19399	38797
100101	4981	9961	19923	39846
100110	5112	10224	20447	40894
100111	5243	10486	20972	41943
101000	5374	10748	21496	42992
101001	5505	11010	22020	44040
101010	5636	11272	22544	45089
101011	5767	11534	23069	46137
101100	5898	11796	23593	47186

Table 4-8 System Frequencies from 32.768-kHz Reference (Continued)

To obtain clock frequency in kilohertz, find counter modulus in the left column, then look in appropriate prescaler cell. Shaded cells contain values that exceed specified maximum system frequency.

Modulus Y	Prescaler			
	[W:X] = 00	[W:X] = 01	[W:X] = 10	[W:X] = 11
101101	6029	12059	24117	48234
101110	6160	12321	24642	49283
101111	6291	12583	25166	50332
110000	6423	12845	25690	51380
110001	6554	13107	26214	52428
110010	6685	13369	26739	53477
110011	6816	13631	27263	54526
110100	6947	13894	27787	55575
110101	7078	14156	28312	56623
110110	7209	14418	28836	57672
110111	7340	14680	29360	58720
111000	7471	14942	2988	59769
111001	7602	15204	30409	60817
111010	7733	15466	30933	61866
111011	7864	15729	31457	62915
111100	7995	15991	31982	63963
111101	8126	16253	32506	65011
111110	8258	16515	33030	66060
111111	8389	16777	33554	67109

4

4.3.3 External Bus Clock

The state of the external clock division bit (EDIV) in SYNCR determines clock rate for the external bus clock signal (ECLK) available on pin ADDR23. ECLK is a bus clock for MC6800 devices and peripherals. ECLK frequency can be set to system clock frequency divided by eight or system clock frequency divided by sixteen. The clock is enabled by the CS10 field in chip select pin assignment register 1 (CSPAR1). ECLK operation during low-power stop is described in the following paragraph. Refer to **4.8 Chip Selects** for more information about the external bus clock.

4.3.4 Low-Power Operation

Low-power operation is initiated by the CPU32. To reduce power consumption selectively, the CPU can set the STOP bits in each module configuration register. To minimize overall microcontroller power consumption, the CPU can execute the LPSTOP instruction, which causes the SIM to turn off the system clock.

When individual module STOP bits are set, clock signals inside each module are turned off, but module registers are still accessible.

When the CPU executes LPSTOP, a special CPU space bus cycle writes a copy of the current interrupt mask into the clock control logic. The SIM brings the MCU out of low-power operation when either an interrupt of higher priority than the stored mask or a reset occurs. Refer to **4.5.4.2 LPSTOP Broadcast Cycle** and **SECTION 5 CENTRAL PROCESSING UNIT** for more information.

During a low-power stop, unless the system clock signal is supplied by an external source and that source is removed, the SIM clock control logic and the SIM clock signal (SIMCLK) continue to operate. The periodic interrupt timer and input logic for the $\overline{\text{RESET}}$ and $\overline{\text{IRQ}}$ pins are clocked by SIMCLK. The SIM can also continue to generate the CLKOUT signal while in low-power mode.

The stop mode system integration module clock (STSIM) and stop mode external clock (STEXT) bits in SYNCR determine clock operation during low-power stop. **Table 4-9** is a summary of the effects of STSIM and STEXT. MODCLK value is the logic level on the MODCLK pin during the last reset before LPSTOP execution. Any clock in the off state is held low. If the synthesizer VCO is turned off during LPSTOP, there is a PLL relock delay after the VCO is turned back on.

Table 4-9 Clock Control

Mode	Pins		SYNCR Bits		Clock Status		
	MODCLK	EXTAL	STSIM	STEXT	SIMCLK	CLKOUT	ECLK
No	0	External Clock	X	X	External Clock	External Clock	External Clock
Yes	0	External Clock	0	0	External Clock	Off	Off
Yes	0	External Clock	0	1	External Clock	External Clock	External Clock
Yes	0	External Clock	1	0	External Clock	Off	Off
Yes	0	External Clock	1	1	External Clock	External Clock	External Clock
No	1	Crystal or Reference	X	X	VCO	VCO	VCO
Yes	1	Crystal or Reference	0	0	Crystal or Reference	Off	Off
Yes	1	Crystal or Reference	0	1	Crystal or Reference	Crystal/Reference	Off
Yes	1	Crystal or Reference	1	0	VCO	Off	Off
Yes	1	Crystal or Reference	1	1	VCO	VCO	VCO

4.3.5 Loss of Reference Signal

The state of the reset enable (RSTEN) bit in SYNCR determines what happens when clock logic detects a reference failure.

When RSTEN is cleared (default state out of reset), the clock synthesizer is forced into an operating condition referred to as limp mode. Limp mode frequency varies from device to device, but maximum limp frequency does not exceed one half maximum system clock when X = 0, or maximum system clock frequency when X = 1.

When RSTEN is set, the SIM resets the MCU.

The limp status bit (SLIMP) in SYNCR indicates whether the synthesizer has a reference signal. It is set when a reference failure is detected.

4.4 External Bus Interface

The external bus interface (EBI) transfers information between the internal MCU bus and external devices. **Figure 4-7** shows a basic system with external memory and peripherals.

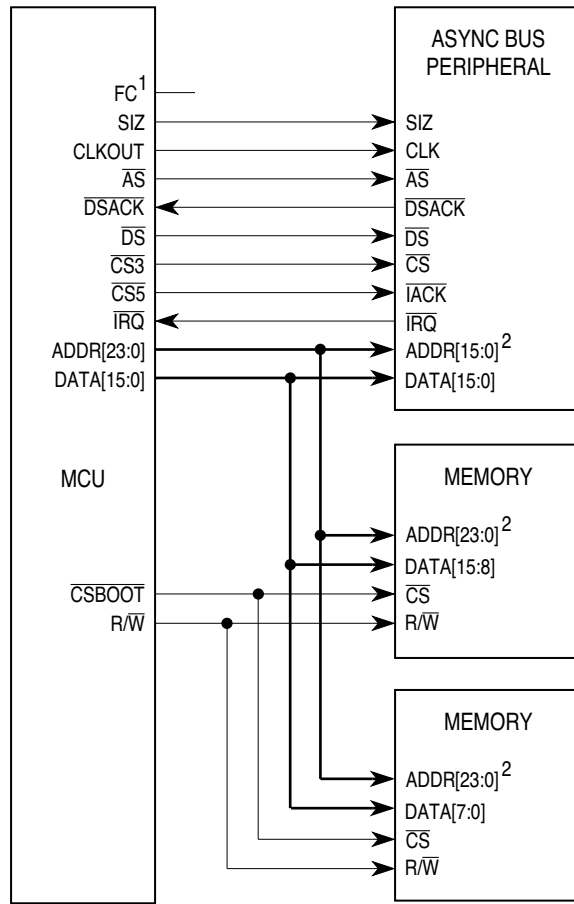

1. Can be decoded to provide additional address space.
 2. Varies depending upon peripheral memory size.

32 EXAMPLE SYS BLOCK

Figure 4-7 MCU Basic System

The external bus has 24 address lines and 16 data lines. The EBI provides dynamic sizing between 8-bit and 16-bit data accesses. It supports byte, word, and long-word transfers. Ports are accessed through the use of asynchronous cycles controlled by the data transfer (SIZ1 and SIZ0) and data size acknowledge pins ($\overline{DSACK1}$ and $\overline{DSACK0}$). Multiple bus cycles may be required for a transfer to or from an 8-bit port.

The maximum number of bits transferred during an access is referred to as port width. Widths of eight and sixteen bits can be accessed by asynchronous bus cycles controlled by the data size (SIZ[1:0]) and the data and size acknowledge ($\overline{DSACK[1:0]}$) signals. Multiple bus cycles may be required for a dynamically-sized transfer.

To add flexibility and minimize the necessity for external logic, MCU chip-select logic can be synchronized with EBI transfers. Refer to **4.8 Chip Selects** for more information.

4.4.1 Bus Signals

The address bus provides addressing information to external devices. The data bus transfers 8-bit and 16-bit data between the MCU and external devices. Strobe signals, one for the address bus and another for the data bus, indicate the validity of an address and provide timing information for data.

Control signals indicate the beginning of each bus cycle, the address space it is to take place in, the size of the transfer, and the type of cycle. External devices decode these signals and respond to transfer data and terminate the bus cycle. The EBI operates in an asynchronous mode for any port width.

4.4.1.1 Address Bus

Bus signals ADDR[23:0] define the address of the byte (or the most significant byte) to be transferred during a bus cycle. The MCU places the address on the bus at the beginning of a bus cycle. The address is valid while \overline{AS} is asserted.

4.4.1.2 Address Strobe

Address strobe \overline{AS} is a timing signal that indicates the validity of an address on the address bus and of many control signals. It is asserted one-half clock after the beginning of a bus cycle.

4.4.1.3 Data Bus

Signals DATA[15:0] form a bidirectional, nonmultiplexed parallel bus that transfers data to or from the MCU. A read or write operation can transfer eight or sixteen bits of data in one bus cycle. During a read cycle, the data is latched by the MCU on the last falling edge of the clock for that bus cycle. For a write cycle, all 16 bits of the data bus are driven, regardless of the port width or operand size. The MCU places the data on the data bus one-half clock cycle after \overline{AS} is asserted in a write cycle.

4.4.1.4 Data Strobe

Data strobe (\overline{DS}) is a timing signal. For a read cycle, the MCU asserts \overline{DS} to signal an external device to place data on the bus. \overline{DS} is asserted at the same time as \overline{AS} during a read cycle. For a write cycle, \overline{DS} signals an external device that data on the bus is valid. The MCU asserts \overline{DS} one full clock cycle after the assertion of \overline{AS} during a write cycle.

4.4.1.5 Read/Write Signal

The read/write signal (R/\overline{W}) determines the direction of the transfer during a bus cycle. This signal changes state, when required, at the beginning of a bus cycle, and is valid while \overline{AS} is asserted. R/\overline{W} only transitions when a write cycle is preceded by a read cycle or vice versa. The signal may remain low for two consecutive write cycles.

4.4.1.6 Size Signals

Size signals (SIZ[1:0]) indicate the number of bytes remaining to be transferred during an operand cycle. They are valid while the address strobe (\overline{AS}) is asserted. **Table 4-10** shows SIZ0 and SIZ1 encoding.

Table 4-10 Size Signal Encoding

SIZ1	SIZ0	Transfer Size
0	1	Byte
1	0	Word
1	1	3 Byte
0	0	Long Word

4.4.1.7 Function Codes

The CPU generates function code output signals FC[2:0] to indicate the type of activity occurring on the data or address bus. These signals can be considered address extensions that can be externally decoded to determine which of eight external address spaces is accessed during a bus cycle.

Address space 7 is designated CPU space. CPU space is used for control information not normally associated with read or write bus cycles. Function codes are valid while \overline{AS} is asserted.

Table 4-11 shows address space encoding.

Table 4-11 Address Space Encoding

FC2	FC1	FC0	Address Space
0	0	0	Reserved
0	0	1	User Data Space
0	1	0	User Program Space
0	1	1	Reserved
1	0	0	Reserved
1	0	1	Supervisor Data Space
1	1	0	Supervisor Program Space
1	1	1	CPU Space

The supervisor bit in the status register determines whether the CPU is operating in supervisor or user mode. Addressing mode and the instruction being executed determine whether a memory access is to program or data space.

4.4.1.8 Data and Size Acknowledge Signals

During normal bus transfers, external devices assert the data and size acknowledge signals ($\overline{DSACK}[1:0]$) to indicate port width to the MCU. During a read cycle, these signals tell the MCU to terminate the bus cycle and to latch data. During a write cycle, the signals indicate that an external device has successfully stored data and that the cycle can terminate. $\overline{DSACK}[1:0]$ can also be supplied internally by chip-select logic. Refer to **4.8 Chip Selects** for more information.

4.4.1.9 Bus Error Signal

The bus error signal \overline{BERR} is asserted when a bus cycle is not properly terminated by \overline{DSACK} or \overline{AVEC} assertion. \overline{BERR} can also be asserted at the same time as \overline{DSACK} , provided the appropriate timing requirements are met. Refer to **4.5.5 Bus Exception Control Cycles** for more information.

The internal bus monitor can generate the $\overline{\text{BERR}}$ signal for internal and internal-to-external transfers. An external bus master must provide its own $\overline{\text{BERR}}$ generation and drive the $\overline{\text{BERR}}$ pin, because the internal $\overline{\text{BERR}}$ monitor has no information about transfers initiated by an external bus master. Refer to **4.5.6 External Bus Arbitration** for more information.

4.4.1.10 Halt Signal

The halt signal ($\overline{\text{HALT}}$) can be asserted by an external device for debugging purposes to cause single bus cycle operation or (in combination with $\overline{\text{BERR}}$) a retry of a bus cycle in error. The $\overline{\text{HALT}}$ signal affects external bus cycles only, so a program not requiring the use of external bus may continue executing, unaffected by the $\overline{\text{HALT}}$ signal. When the MCU completes a bus cycle with the $\overline{\text{HALT}}$ signal asserted, $\text{DATA}[15:0]$ is placed in the high-impedance state, and bus control signals are driven inactive; the address, function code, size, and read/write signals remain in the same state. If $\overline{\text{HALT}}$ is still asserted once bus mastership is returned to the MCU, the address, function code, size, and read/write signals are again driven to their previous states. The MCU does not service interrupt requests while it is halted. Refer to **4.5.5 Bus Exception Control Cycles** for further information.

4.4.1.11 Autovector Signal

The autovector signal $\overline{\text{AVEC}}$ can be used to terminate external interrupt acknowledge cycles. Assertion of $\overline{\text{AVEC}}$ causes the CPU32 to generate vector numbers to locate an interrupt handler routine. If it is continuously asserted, autovectors are generated for all external interrupt requests. $\overline{\text{AVEC}}$ is ignored during all other bus cycles. Refer to **4.7 Interrupts** for more information. $\overline{\text{AVEC}}$ for external interrupt requests can also be supplied internally by chip-select logic. Refer to **4.8 Chip Selects** for more information. The autovector function is disabled when there is an external bus master. Refer to **4.5.6 External Bus Arbitration** for more information.

4.4.2 Dynamic Bus Sizing

The MCU dynamically interprets the port size of an addressed device during each bus cycle, allowing operand transfers to or from 8-bit and 16-bit ports.

During an operand transfer cycle, an external device signals its port size and indicates completion of the bus cycle to the MCU through the use of the $\overline{\text{DSACK}}$ inputs, as shown in **Table 4-12**. Chip-select logic can generate data and size acknowledge signals for an external device. Refer to **4.8 Chip Selects** for further information.

Table 4-12 Effect of $\overline{\text{DSACK}}$ Signals

DSACK1	DSACK0	Result
1	1	Insert Wait States in Current Bus Cycle
1	0	Complete Cycle — Data Bus Port Size is 8 Bits
0	1	Complete Cycle — Data Bus Port Size is 16 Bits
0	0	Reserved

If the CPU is executing an instruction that reads a long-word operand from a 16-bit port, the MCU latches the 16 bits of valid data and then runs another bus cycle to ob-

tain the other 16 bits. The operation for an 8-bit port is similar, but requires four read cycles. The addressed device uses the \overline{DSACK} signals to indicate the port width. For instance, a 16-bit device always returns \overline{DSACK} for a 16-bit port (regardless of whether the bus cycle is a byte or word operation).

Dynamic bus sizing requires that the portion of the data bus used for a transfer to or from a particular port size be fixed. A 16-bit port must reside on data bus bits [15:0], and an 8-bit port must reside on data bus bits [15:8]. This minimizes the number of bus cycles needed to transfer data and ensures that the MCU transfers valid data.

The MCU always attempts to transfer the maximum amount of data on all bus cycles. For a word operation, it is assumed that the port is 16 bits wide when the bus cycle begins.

Operand bytes are designated as shown in **Figure 4-8**. OP[0:3] represent the order of access. For instance, OP0 is the most significant byte of a long-word operand, and is accessed first, while OP3, the least significant byte, is accessed last. The two bytes of a word-length operand are OP0 (most significant) and OP1. The single byte of a byte-length operand is OP0.

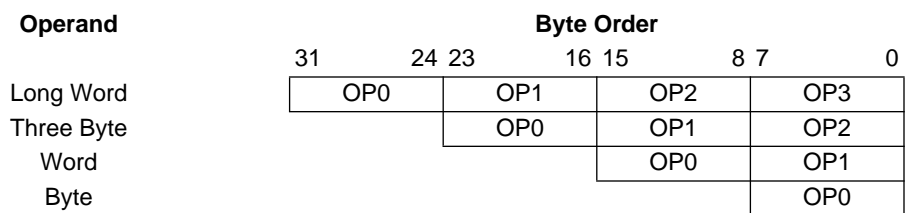

Figure 4-8 Operand Byte Order

4.4.3 Operand Alignment

The EBI data multiplexer establishes the necessary connections for different combinations of address and data sizes. The multiplexer takes the two bytes of the 16-bit bus and routes them to their required positions. Positioning of bytes is determined by the size and address outputs. SIZ1 and SIZ0 indicate the remaining number of bytes to be transferred during the current bus cycle. The number of bytes transferred is equal to or less than the size indicated by SIZ1 and SIZ0, depending on port width.

ADDR0 also affects the operation of the data multiplexer. During an operand transfer, ADDR[23:1] indicate the word base address of the portion of the operand to be accessed, and ADDR0 indicates the byte offset from the base.

4.4.4 Misaligned Operands

CPU32 architecture uses a basic operand size of 16 bits. An operand is misaligned when it overlaps a word boundary. This is determined by the value of ADDR0. When ADDR0 = 0 (an even address), the address is on a word and byte boundary. When ADDR0 = 1 (an odd address), the address is on a byte boundary only. A byte operand is aligned at any address; a word or long-word operand is misaligned at an odd address.

The largest amount of data that can be transferred by a single bus cycle is an aligned word. If the MCU transfers a long-word operand through a 16-bit port, the most significant operand word is transferred on the first bus cycle and the least significant operand word is transferred on a following bus cycle.

4.4.5 Operand Transfer Cases

Table 4-13 is a summary of how operands are aligned for various types of transfers. OPn entries are portions of a requested operand that are read or written during a bus cycle and are defined by SIZ1, SIZ0, and ADDR0 for that bus cycle. The following paragraphs discuss all the allowable transfer cases in detail.

Table 4-13 Operand Transfer Cases

Num	Transfer Case	SIZ [1:0]	ADDR0	DSACK [1:0]	Read Cycles		Write Cycles		Next Cycle
					DATA [15:8]	DATA [7:0]	DATA [15:8]	DATA [7:0]	
1	Byte to 8-Bit Port (Even/Odd)	01	X	10	OP0	—	OP0	(OP0)	—
2	Byte to 16-Bit Port (Even)	01	0	01	OP0	—	OP0	(OP0)	—
3	Byte to 16-Bit Port (Odd)	01	1	01	—	OP0	(OP0)	OP0	—
4	Word to 8-Bit Port (Aligned)	10	0	10	OP0	—	OP0	(OP1)	1
5	Word to 8-Bit Port (Misaligned) ¹	10	1	10	OP0	—	OP0	(OP0)	1
6	Word to 16-Bit Port (Aligned)	10	0	11	OP0	OP1	OP0	OP1	—
7	Word to 16-Bit Port (Misaligned) ¹	10	1	01	—	OP0	(OP0)	OP0	2
8	Long Word to 8-Bit Port (Aligned)	00	0	10	OP0	—	OP0	(OP1)	13
9	Long Word to 8-Bit Port (Misaligned) ¹	10	1	10	OP0	—	OP0	(OP0)	12
10	Long Word to 16-Bit Port (Aligned)	00	0	01	OP0	OP1	OP0	OP1	6
11	Long Word to 16-Bit Port (Misaligned) ¹	10	1	01	—	OP0	(OP0)	OP0	2
12	3 Byte to 8-Bit Port (Aligned) ²	11	0	10	OP0	—	OP0	(OP1)	5
13	3 Byte to 8-Bit Port (Misaligned) ²	11	1	10	OP0	—	OP0	(OP0)	4

1. The CPU32 does not support misaligned transfers.
2. Three-byte transfer cases occur only as a result of a long word to byte transfer.

4.5 Bus Operation

Internal microcontroller modules are typically accessed in two system clock cycles, with no wait states. Regular external bus cycles use handshaking between the MCU and external peripherals to manage transfer size and data. These accesses take three system clock cycles, again with no wait states. During regular cycles, wait states can be inserted as needed by bus control logic. Refer to **4.5.2 Regular Bus Cycles** for more information.

Fast-termination cycles, which are two-cycle external accesses with no wait states, use chip-select logic to generate handshaking signals internally. Chip-select logic can also be used to insert wait states before internal generation of handshaking signals. Refer to **4.5.3 Fast Termination Cycles** and **4.8 Chip Selects** for more information. Bus control signal timing, as well as chip-select signal timing, are specified in **APPENDIX A ELECTRICAL CHARACTERISTICS**. Refer to the *SIM Reference Manual* (SIM-RM/AD) for more information about each type of bus cycle.

The MCU is responsible for de-skewing signals it issues at both the start and the end of a cycle. In addition, the MCU is responsible for de-skewing acknowledge and data signals from peripheral devices.

4.5.1 Synchronization to CLKOUT

External devices connected to the MCU bus can operate at a clock frequency different from the frequencies of the MCU as long as the external devices satisfy the interface signal timing constraints. Although bus cycles are classified as asynchronous, they are interpreted relative to the MCU system clock output (CLKOUT).

Descriptions are made in terms of individual system clock states, labeled {S0, S1, S2,..., SN}. The designation “state” refers to the logic level of the clock signal, and does not correspond to any implemented machine state. A clock cycle consists of two successive states. Refer to **APPENDIX A ELECTRICAL CHARACTERISTICS** for more information.

Bus cycles terminated by \overline{DSACK} assertion normally require a minimum of three CLKOUT cycles. To support systems that use CLKOUT to generate \overline{DSACK} and other inputs, asynchronous input setup time and asynchronous input hold times are specified. When these specifications are met, the MCU is guaranteed to recognize the appropriate signal on a specific edge of the CLKOUT signal.

For a read cycle, when assertion of \overline{DSACK} is recognized on a particular falling edge of the clock, valid data is latched into the MCU on the next falling clock edge, provided that the data meets the data setup time. In this case, the parameter for asynchronous operation can be ignored.

When a system asserts \overline{DSACK} for the required window around the falling edge of S2 and obeys the bus protocol by maintaining \overline{DSACK} and \overline{BERR} or \overline{HALT} until and throughout the clock edge that negates \overline{AS} , no wait states are inserted. The bus cycle runs at the maximum speed of three clocks per cycle.

To ensure proper operation in a system synchronized to CLKOUT when either \overline{BERR} , or \overline{BERR} and \overline{HALT} is asserted after \overline{DSACK} , \overline{BERR} (or \overline{BERR} and \overline{HALT}) assertion must satisfy the appropriate data-in setup and hold times before the falling edge of the clock cycle after \overline{DSACK} is recognized.

4.5.2 Regular Bus Cycles

The following paragraphs contain a discussion of cycles that use external bus control logic. Refer to **4.5.3 Fast Termination Cycles** for information about fast cycles.

To initiate a transfer, the MCU asserts an address and the SIZ[1:0] signals. The SIZ signals and ADDR0 are externally decoded to select the active portion of the data bus (refer to **4.4.2 Dynamic Bus Sizing**). When \overline{AS} , \overline{DS} , and R/\overline{W} are valid, a peripheral device either places data on the bus (read cycle) or latches data from the bus (write cycle), then asserts a $\overline{DSACK}[1:0]$ combination that indicates port size.

The $\overline{DSACK}[1:0]$ signals can be asserted before the data from a peripheral device is valid on a read cycle. To ensure valid data is latched into the MCU, a maximum period between \overline{DSACK} assertion and \overline{DS} assertion is specified.

There is no specified maximum for the period between the assertion of \overline{AS} and \overline{DSACK} . Although the MCU can transfer data in a minimum of three clock cycles when

the cycle is terminated with \overline{DSACK} , the MCU inserts wait cycles in clock period increments until either \overline{DSACK} signal goes low.

NOTE

The SIM bus monitor asserts \overline{BERR} when response time exceeds a predetermined limit. Bus monitor period is determined by the BMT field in SYPCR. The bus monitor cannot be disabled; maximum monitor period is 64 system clock cycles.

If no peripheral responds to an access, or if an access is invalid, external logic should assert the \overline{BERR} or \overline{HALT} signals to abort the bus cycle (when \overline{BERR} and \overline{HALT} are asserted simultaneously, the CPU32 acts as though only \overline{BERR} is asserted). If bus termination signals are not asserted within a specified period, the bus monitor terminates the cycle.

4.5.2.1 Read Cycle

During a read cycle, the MCU transfers data from an external memory or peripheral device. If the instruction specifies a long-word or word operation, the MCU attempts to read two bytes at once. For a byte operation, the MCU reads one byte. The portion of the data bus from which each byte is read depends on operand size, peripheral address, and peripheral port size. **Figure 4-9** is a flowchart of a word read cycle. Refer to **4.4.2 Dynamic Bus Sizing**, **4.4.4 Misaligned Operands**, and the *SIM Reference Manual* (SIMRM/AD) for more information.

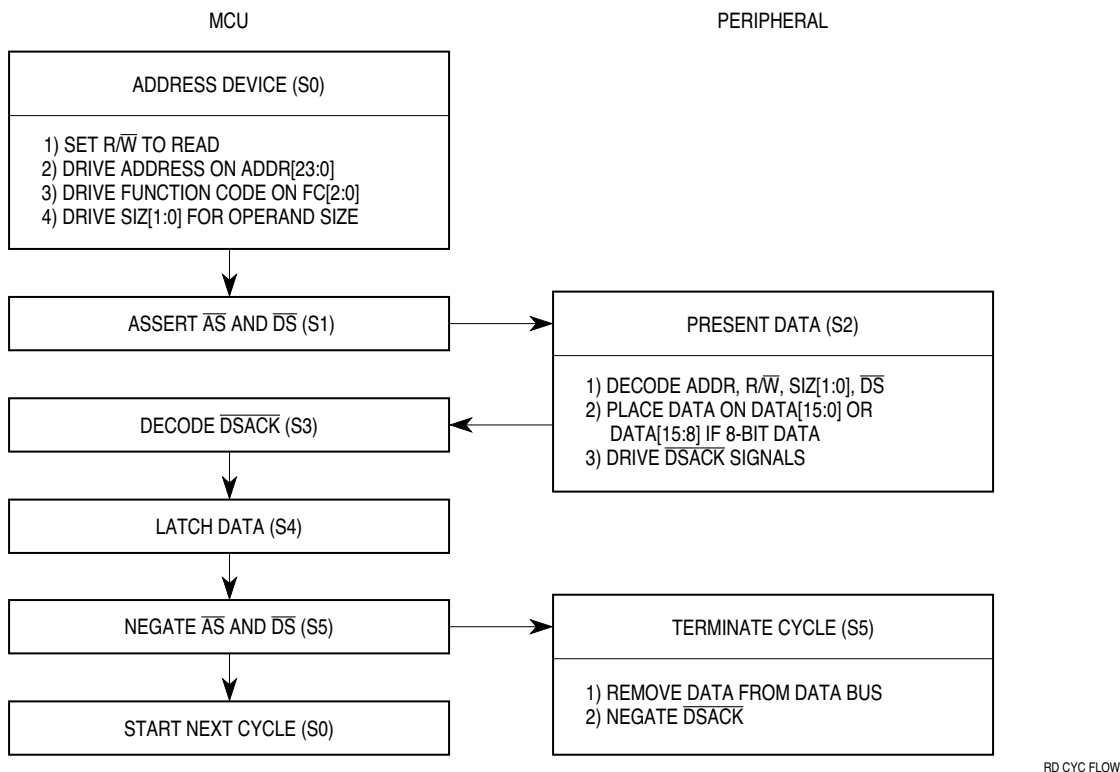

Figure 4-9 Word Read Cycle Flowchart

4.5.2.2 Write Cycle

During a write cycle, the MCU transfers data to an external memory or peripheral device. If the instruction specifies a long-word or word operation, the MCU attempts to write two bytes at once. For a byte operation, the MCU writes one byte. The portion of the data bus upon which each byte is written depends on operand size, peripheral address, and peripheral port size.

Refer to **4.4.2 Dynamic Bus Sizing** and **4.4.4 Misaligned Operands** for more information. **Figure 4-10** is a flowchart of a write-cycle operation for a word transfer. Refer to the *SIM Reference Manual* (SIMRM/AD) for more information.

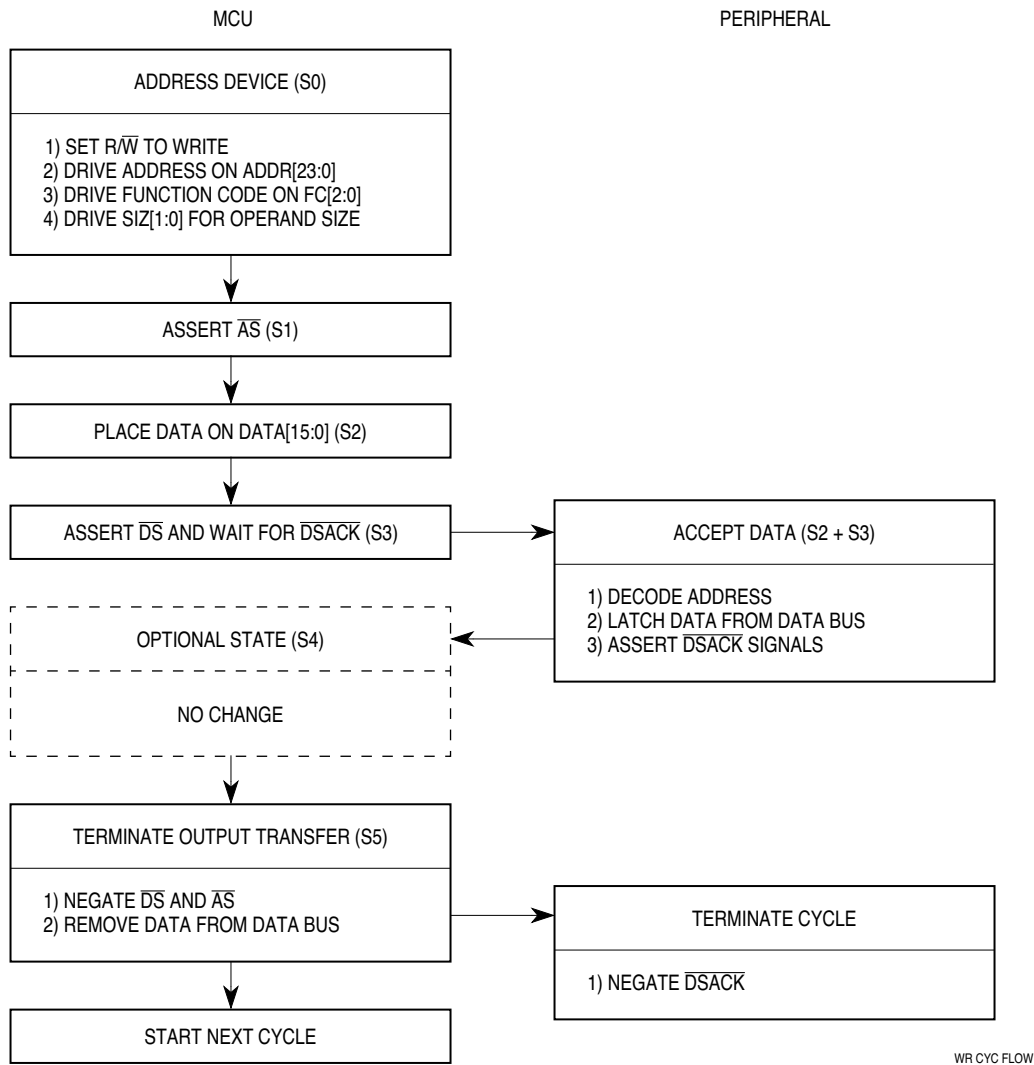

Figure 4-10 Write Cycle Flowchart

4.5.3 Fast Termination Cycles

When an external device has a fast access time, the chip-select circuit fast-termination option can provide a two-cycle external bus transfer. Because the chip-select circuits

are driven from the system clock, the bus cycle termination is inherently synchronized with the system clock.

If multiple chip selects are to be used to select the same device that can support fast termination, and match conditions can occur simultaneously, program the $\overline{\text{DSACK}}$ field in each associated chip-select option register for fast termination. Alternately, program one $\overline{\text{DSACK}}$ field for fast termination and the remaining $\overline{\text{DSACK}}$ fields for external termination.

Fast termination cycles use internal handshaking signals generated by the chip-select logic. To initiate a transfer, the MCU asserts an address and the $\text{SIZ}[1:0]$ signals. When $\overline{\text{AS}}$, $\overline{\text{DS}}$, and $\text{R}/\overline{\text{W}}$ are valid, a peripheral device either places data on the bus (read cycle) or latches data from the bus (write cycle). At the appropriate time, chip-select logic asserts data and size acknowledge signals.

The $\overline{\text{DSACK}}$ option fields in the chip-select option registers determine whether internally generated $\overline{\text{DSACK}}$ or externally generated $\overline{\text{DSACK}}$ are used. For fast termination cycles, the F-term encoding (%1110) must be used. Refer to **4.8.1 Chip-Select Registers** for information about fast-termination setup.

To use fast-termination, an external device must be fast enough to have data ready, within the specified setup time, by the falling edge of S4 . Refer to **APPENDIX A ELECTRICAL CHARACTERISTICS** for tabular information about fast termination timing.

When fast termination is in use, $\overline{\text{DS}}$ is asserted during read cycles but not during write cycles. The STRB field in the chip-select option register used must be programmed with the address strobe encoding to assert the chip select signal for a fast-termination write.

4.5.4 CPU Space Cycles

Function code signals $\text{FC}[2:0]$ designate which of eight external address spaces is accessed during a bus cycle. Address space 7 is designated CPU space. CPU space is used for control information not normally associated with read or write bus cycles. Function codes are valid only while $\overline{\text{AS}}$ is asserted. Refer to **4.4.1.7 Function Codes** for more information on codes and encoding.

During a CPU space access, $\text{ADDR}[19:16]$ are encoded to reflect the type of access being made. **Figure 4-11** shows the three encodings used by 68300 family microcontrollers. These encodings represent breakpoint acknowledge (Type \$0) cycles low power stop broadcast (Type \$3) cycles, and interrupt acknowledge (Type \$F) cycles. Refer to **4.7 Interrupts** for information about interrupt acknowledge bus cycles.

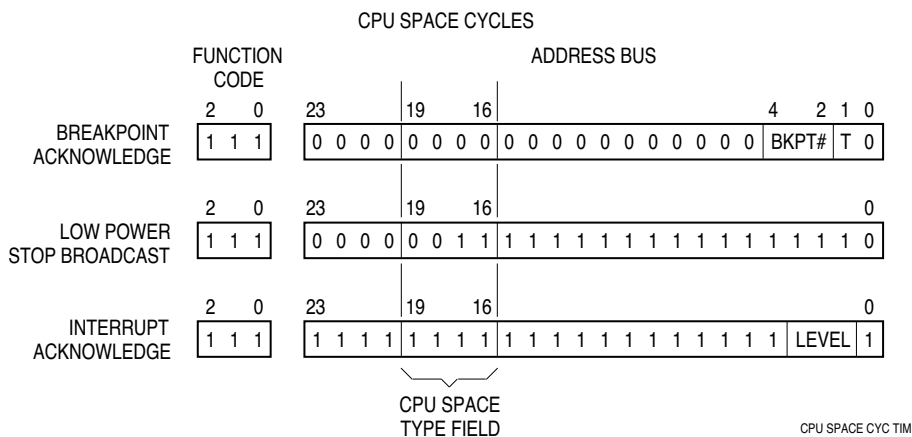

Figure 4-11 CPU Space Address Encoding

4.5.4.1 Breakpoint Acknowledge Cycle

Breakpoints stop program execution at a predefined point during system development. Breakpoints can be used alone or in conjunction with the background debugging mode. The following paragraphs discuss breakpoint processing when background debugging mode is not enabled. See **SECTION 5 CENTRAL PROCESSING UNIT** for more information on exception processing and the background debugging mode.

In M68300 microcontrollers, both hardware and software can initiate breakpoints.

4.5.4.1.1 Software Breakpoints

The CPU32 BKPT instruction allows the user to insert breakpoints through software. The CPU responds to this instruction by initiating a breakpoint-acknowledge read cycle in CPU space. It places the breakpoint acknowledge (%0000) code on ADDR[19:16], the breakpoint number (bits [2:0] of the BKPT opcode) in ADDR[4:2], and %0 (indicating a software breakpoint) on ADDR1.

The external breakpoint circuitry decodes the function code and address lines and responds by either asserting \overline{BERR} or placing an instruction word on the data bus and asserting \overline{DSACK} .

If the bus cycle is terminated by \overline{DSACK} , the CPU32 reads the instruction on the data bus and inserts the instruction into the pipeline. (For 8-bit ports, this instruction fetch may require two read cycles.)

If the bus cycle is terminated by \overline{BERR} , the CPU32 then performs illegal-instruction exception processing: it acquires the number of the illegal-instruction exception vector, computes the vector address from this number, loads the content of the vector address into the PC, and jumps to the exception handler routine at that address.

4.5.4.1.2 Hardware Breakpoints

Assertion of the \overline{BKPT} input initiates a hardware breakpoint. The CPU responds by initiating a breakpoint-acknowledge read cycle in CPU space. It places \$00001E on the

address bus. (The breakpoint acknowledge code of %0000 is placed on ADDR[19:16], the breakpoint number value of %111 is placed on ADDR[4:2], and ADDR1 is set to 1, indicating a hardware breakpoint.)

The external breakpoint circuitry decodes the function code and address lines, places an instruction word on the data bus, and asserts $\overline{\text{BERR}}$. The CPU then performs hardware breakpoint exception processing: it acquires the number of the hardware breakpoint exception vector, computes the vector address from this number, loads the content of the vector address into the PC, and jumps to the exception handler routine at that address. If the external device asserts $\overline{\text{DSACK}}$ rather than $\overline{\text{BERR}}$, the CPU ignores the breakpoint and continues processing.

When $\overline{\text{BKPT}}$ assertion is synchronized with an instruction prefetch, processing of the breakpoint exception occurs at the end of that instruction. The prefetched instruction is “tagged” with the breakpoint when it enters the instruction pipeline, and the breakpoint exception occurs after the instruction executes. If the pipeline is flushed before the tagged instruction is executed, no breakpoint occurs. When $\overline{\text{BKPT}}$ assertion is synchronized with an operand fetch, exception processing occurs at the end of the instruction during which $\overline{\text{BKPT}}$ is latched.

Refer to the *CPU32 Reference Manual* (CPU32RM/AD) and the *SIM Reference Manual* (SIMRM/AD) for additional information.

BREAKPOINT OPERATION FLOW

CPU32

PERIPHERAL

ACKNOWLEDGE BREAKPOINT

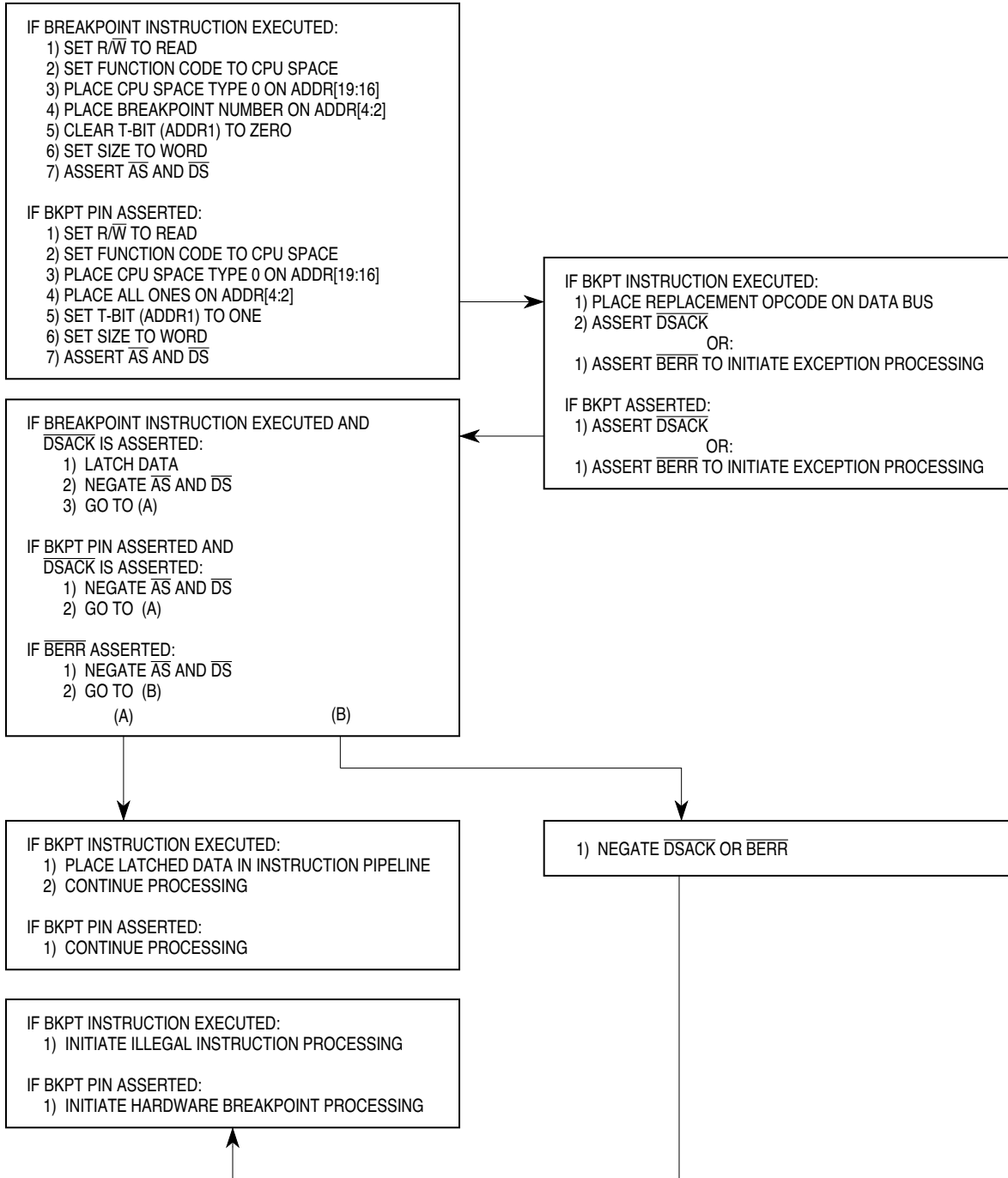

4

Figure 4-12 Breakpoint Operation Flowchart

1110A

4.5.4.2 LPSTOP Broadcast Cycle

the STOP bits in each module configuration register or the SIM can turn off system clocks after execution of the LPSTOP instruction. When the CPU executes LPSTOP, the LPSTOP broadcast cycle is generated. The SIM brings the MCU out of low-power mode when either an interrupt of higher priority than the stored mask or a reset occurs. Refer to **4.3.4 Low-Power Operation** and **SECTION 5 CENTRAL PROCESSING UNIT** for more information.

During an LPSTOP broadcast cycle, the CPU performs a CPU space write to address \$3FFFE. This write puts a copy of the interrupt mask value in the clock control logic. The mask is encoded on the data bus as shown in **Figure 4-13**. The LPSTOP CPU space cycle is shown externally (if the bus is available) as an indication to external devices that the MCU is going into low-power stop mode. The SIM provides an internally generated \overline{DSACK} response to this cycle. The timing of this bus cycle is the same as for a fast write cycle.

15	14	13	12	11	10	9	8	7	6	5	4	3	2	1	0
0	0	0	0	0	0	0	0	0	0	0	0	0	0	0	IP MASK

Figure 4-13 LPSTOP Interrupt Mask Level

4.5.5 Bus Exception Control Cycles

An external device or a chip-select circuit must assert at least one of the $\overline{DSACK}[1:0]$ signals or the \overline{AVEC} signal to terminate a bus cycle normally. Bus error processing occurs when bus cycles are not terminated in the expected manner. The internal bus monitor can be used to generate \overline{BERR} internally, causing a bus error exception to be taken. Bus cycles can also be terminated by assertion of the external \overline{BERR} or \overline{HALT} signal, or by assertion of the two signals simultaneously.

Acceptable bus cycle termination sequences are summarized as follows. The case numbers refer to **Table 4-14**, which indicates the results of each type of bus cycle termination.

Normal Termination

\overline{DSACK} is asserted; \overline{BERR} and \overline{HALT} remain negated (case 1).

Halt Termination

\overline{HALT} is asserted at the same time or before \overline{DSACK} , and \overline{BERR} remains negated (case 2).

Bus Error Termination

\overline{BERR} is asserted in lieu of, at the same time as, or before \overline{DSACK} (case 3), or after \overline{DSACK} (case 4), and \overline{HALT} remains negated; \overline{BERR} is negated at the same time or after \overline{DSACK} .

Retry Termination

$\overline{\text{HALT}}$ and $\overline{\text{BERR}}$ are asserted in lieu of, at the same time as, or before $\overline{\text{DSACK}}$ (case 5) or after $\overline{\text{DSACK}}$ (case 6); $\overline{\text{BERR}}$ is negated at the same time or after $\overline{\text{DSACK}}$; $\overline{\text{HALT}}$ may be negated at the same time or after $\overline{\text{BERR}}$.

Table 4-14 shows various combinations of control signal sequences and the resulting bus cycle terminations.

Table 4-14 $\overline{\text{DSACK}}$, $\overline{\text{BERR}}$, and $\overline{\text{HALT}}$ Assertion Results

Case Number	Control Signal	Asserted on Rising Edge of State		Result
		N	N + 2	
1	$\overline{\text{DSACK}}$ $\overline{\text{BERR}}$ $\overline{\text{HALT}}$	A NA NA	S NA X	Normal termination.
2	$\overline{\text{DSACK}}$ - $\overline{\text{BERR}}$ $\overline{\text{HALT}}$	A NA A/S	S NA S	Halt termination: normal cycle terminate and halt. Continue when $\overline{\text{HALT}}$ is negated.
3	$\overline{\text{DSACK}}$ - $\overline{\text{BERR}}$ $\overline{\text{HALT}}$	NA/A A NA	X S X	Bus error termination: terminate and take bus error exception, possibly deferred.
4	$\overline{\text{DSACK}}$ - $\overline{\text{BERR}}$ $\overline{\text{HALT}}$	A A NA	X S NA	Bus error termination: terminate and take bus error exception, possibly deferred.
5	$\overline{\text{DSACK}}$ - $\overline{\text{BERR}}$ $\overline{\text{HALT}}$	NA/A A A/S	X S S	Retry termination: terminate and retry when $\overline{\text{HALT}}$ is negated.
6	$\overline{\text{DSACK}}$ - $\overline{\text{BERR}}$ $\overline{\text{HALT}}$	A NA NA	X A A	Retry termination: terminate and retry when $\overline{\text{HALT}}$ is negated.

NOTES:

- N = The number of current even bus state (S2, S4, etc.).
- A = Signal is asserted in this bus state.
- NA = Signal is not asserted in this state.
- X = Don't care.
- S = Signal was asserted in previous state and remains asserted in this state.

To properly control termination of a bus cycle for a retry or a bus error condition, $\overline{\text{DSACK}}$, $\overline{\text{BERR}}$, and $\overline{\text{HALT}}$ must be asserted and negated with the rising edge of the MCU clock. This ensures that when two signals are asserted simultaneously, the required setup time and hold time for both of them are met for the same falling edge of the MCU clock. (Refer to **APPENDIX A ELECTRICAL CHARACTERISTICS** for timing requirements.) External circuitry that provides these signals must be designed with these constraints in mind, or else the internal bus monitor must be used.

$\overline{\text{DSACK}}$, $\overline{\text{BERR}}$, and $\overline{\text{HALT}}$ may be negated after $\overline{\text{AS}}$ is negated.

WARNING

If $\overline{\text{DSACK}}$ or $\overline{\text{BERR}}$ remain asserted into S2 of the next bus cycle, that cycle may be terminated prematurely.

4.5.5.1 Bus Errors

The CPU32 treats bus errors as a type of exception. Bus error exception processing begins when the CPU detects assertion of the $\overline{\text{IMB BERR}}$ signal (by the internal bus monitor or an external source) while the $\overline{\text{HALT}}$ signal remains negated.

$\overline{\text{BERR}}$ assertions do not force immediate exception processing. The signal is synchronized with normal bus cycles and is latched into the CPU32 at the end of the bus cycle in which it was asserted. Because bus cycles can overlap instruction boundaries, bus error exception processing may not occur at the end of the instruction in which the bus cycle begins. Timing of $\overline{\text{BERR}}$ detection/acknowledge is dependent upon several factors:

- Which bus cycle of an instruction is terminated by assertion of $\overline{\text{BERR}}$.
- The number of bus cycles in the instruction during which $\overline{\text{BERR}}$ is asserted.
- The number of bus cycles in the instruction following the instruction in which $\overline{\text{BERR}}$ is asserted.
- Whether $\overline{\text{BERR}}$ is asserted during a program space access or a data space access.

Because of these factors, it is impossible to predict precisely how long after occurrence of a bus error the bus error exception is processed.

CAUTION

The external bus interface does not latch data when an external bus cycle is terminated by a bus error. When this occurs during an instruction prefetch, the IMB precharge state (bus pulled high, or \$FF) is latched into the CPU32 instruction register, with indeterminate results.

4.5.5.2 Double Bus Faults

Exception processing for bus error exceptions follows the standard exception processing sequence. Refer to **SECTION 5 CENTRAL PROCESSING UNIT** for more information about exceptions. However, a special case of bus error, called double bus fault, can abort exception processing.

$\overline{\text{BERR}}$ assertion is not detected until an instruction is complete. The $\overline{\text{BERR}}$ latch is cleared by the first instruction of the $\overline{\text{BERR}}$ exception handler. Double bus fault occurs in two ways:

1. When bus error exception processing begins and a second $\overline{\text{BERR}}$ is detected before the first instruction of the first exception handler is executed.
2. When one or more bus errors occur before the first instruction after a RESET exception is executed.
3. A bus error occurs while the CPU32 is loading information from a bus error stack frame during a return from exception (RTE) instruction.

Multiple bus errors within a single instruction that can generate multiple bus cycles cause a single bus error exception after the instruction has been executed.

Immediately after assertion of a second $\overline{\text{BERR}}$, the MCU halts and drives the $\overline{\text{HALT}}$ line low. Only a reset can restart a halted MCU. However, bus arbitration can still occur (refer to **4.5.6 External Bus Arbitration**). A bus error or address error that occurs after exception processing has been completed (during the execution of the exception handler routine, or later) does not cause a double bus fault. The MCU continues to retry the same bus cycle as long as the external hardware requests it.

4.5.5.3 Retry Operation

$\overline{\text{BERR}}$ and $\overline{\text{HALT}}$ during a bus cycle, the MCU enters the retry sequence. A delayed retry can also occur. The MCU terminates the bus cycle, places the $\overline{\text{AS}}$ and $\overline{\text{DS}}$ signals in their inactive state, and does not begin another bus cycle until the $\overline{\text{BERR}}$ and $\overline{\text{HALT}}$ signals are negated by external logic. After a synchronization delay, the MCU retries the previous cycle using the same address, function codes, data (for a write), and control signals. The $\overline{\text{BERR}}$ signal should be negated before S2 of the read cycle to ensure correct operation of the retried cycle.

If $\overline{\text{BR}}$, $\overline{\text{BERR}}$, and $\overline{\text{HALT}}$ are all asserted on the same cycle, the EBI will enter the rerun sequence but first relinquishes the bus to an external master. Once the external master returns the bus and negates $\overline{\text{BERR}}$ and $\overline{\text{HALT}}$, the EBI runs the previous bus cycle. This feature allows an external device to correct the problem that caused the bus error and then try the bus cycle again.

The MCU retries any read or write cycle of an indivisible read-modify-write operation separately; $\overline{\text{RMC}}$ remains asserted during the entire retry sequence. The MCU will not relinquish the bus while $\overline{\text{RMC}}$ is asserted. Any device that requires the MCU to give up the bus and retry a bus cycle during a read-modify-write cycle must assert $\overline{\text{BERR}}$ and $\overline{\text{BR}}$ only ($\overline{\text{HALT}}$ must remain negated). The bus error handler software should examine the read-modify-write bit in the special status word and take the appropriate action to resolve this type of fault when it occurs.

4.5.5.4 Halt Operation

When $\overline{\text{HALT}}$ is asserted while $\overline{\text{BERR}}$ is not asserted, the MCU halts external bus activity after negation of $\overline{\text{DSACK}}$. The MCU may complete the current word transfer in progress. For a long-word to byte transfer, this could be after S2 or S4. For a word to byte transfer, activity ceases after S2.

Negating and reasserting $\overline{\text{HALT}}$ according to timing requirements provides single-step (bus cycle to bus cycle) operation. The $\overline{\text{HALT}}$ signal affects external bus cycles only, so that a program that does not use external bus can continue executing. During dynamically-sized 8-bit transfers, external bus activity may not stop at the next cycle boundary. Occurrence of a bus error while $\overline{\text{HALT}}$ is asserted causes the CPU32 to initiate a retry sequence.

When the MCU completes a bus cycle while the $\overline{\text{HALT}}$ signal is asserted, the data bus goes to high-impedance state and the $\overline{\text{AS}}$ and $\overline{\text{DS}}$ signals are driven to their inactive states. Address, function code, size, and read/write signals remain in the same state.

The halt operation has no effect on bus arbitration (refer to **4.5.6 External Bus Arbitration**). However, when external bus arbitration occurs while the MCU is halted, address and control signals go to high-impedance state. If $\overline{\text{HALT}}$ is still asserted when the MCU regains control of the bus, address, function code, size, and read/write signals revert to the previous driven states. The MCU cannot service interrupt requests while halted.

4.5.6 External Bus Arbitration

MCU bus design provides for a single bus master at any one time. Either the MCU or an external device can be master. Bus arbitration protocols determine when an external device can become bus master. Bus arbitration requests are recognized during normal processing, $\overline{\text{HALT}}$ assertion, and when the CPU has halted due to a double bus fault.

The bus controller in the MCU manages bus arbitration signals so that the MCU has the lowest priority. External devices that need to obtain the bus must assert bus arbitration signals in the sequences described in the following paragraphs.

Systems that include several devices that can become bus master require external circuitry to assign priorities to the devices, so that when two or more external devices attempt to become bus master at the same time, the one having the highest priority becomes bus master first. The protocol sequence is:

1. An external device asserts bus request signal ($\overline{\text{BR}}$);
2. The MCU asserts the bus grant signal ($\overline{\text{BG}}$) to indicate that the bus is available;
3. An external device asserts the bus grant acknowledge ($\overline{\text{BGACK}}$) signal to indicate that it has assumed bus mastership.

$\overline{\text{BR}}$ can be asserted during a bus cycle or between cycles. $\overline{\text{BG}}$ is asserted in response to $\overline{\text{BR}}$. To guarantee operand coherency, $\overline{\text{BG}}$ is only asserted at the end of operand transfer. Additionally, $\overline{\text{BG}}$ is not asserted until the end of an indivisible read-modify-write operation (when $\overline{\text{RMC}}$ is negated).

If more than one external device can be bus master, required external arbitration must begin when a requesting device receives $\overline{\text{BG}}$. An external device must assert $\overline{\text{BGACK}}$ when it assumes mastership, and must maintain $\overline{\text{BGACK}}$ assertion as long as it is bus master.

Two conditions must be met for an external device to assume bus mastership. The device must receive $\overline{\text{BG}}$ through the arbitration process, and $\overline{\text{BGACK}}$ must be inactive, indicating that no other bus master is active. This technique allows the processing of bus requests during data transfer cycles.

$\overline{\text{BG}}$ is negated a few clock cycles after $\overline{\text{BGACK}}$ transition. However, if bus requests are still pending after $\overline{\text{BG}}$ is negated, the MCU asserts $\overline{\text{BG}}$ again within a few clock cycles. This additional $\overline{\text{BG}}$ assertion allows external arbitration circuitry to select the next bus master before the current master has released the bus.

Refer to **Figure 4-14**, which shows bus arbitration for a single device. The flowchart shows $\overline{\text{BR}}$ negated at the same time $\overline{\text{BGACK}}$ is asserted.

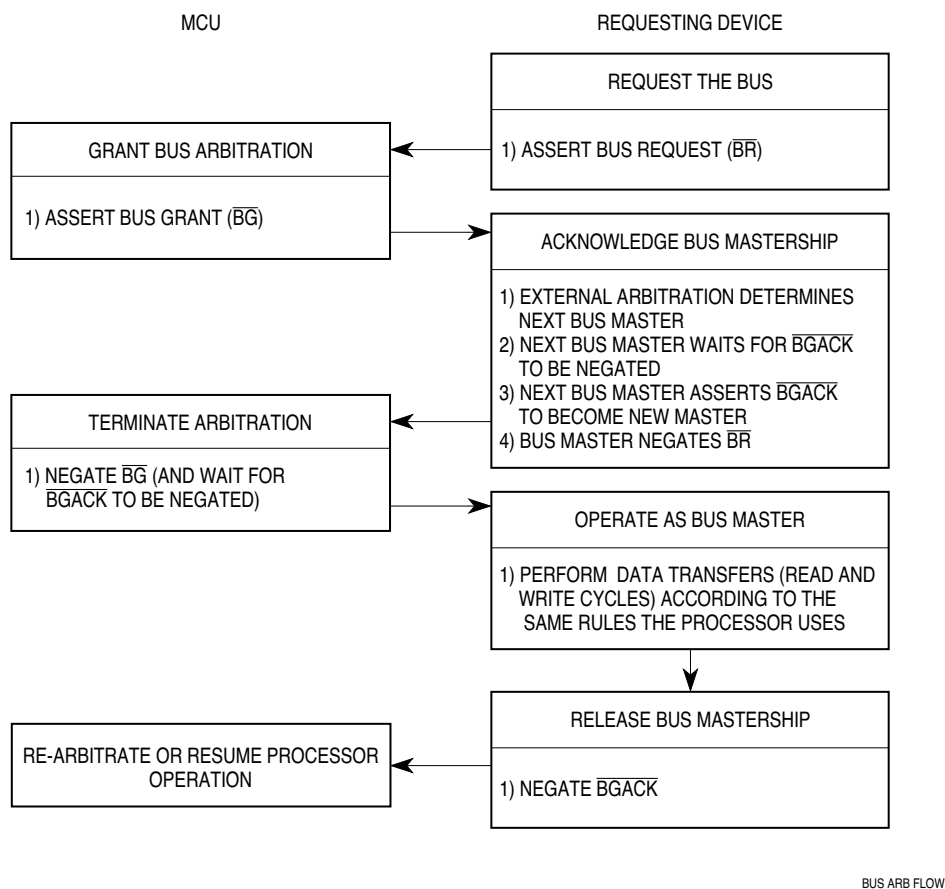

Figure 4-14 Bus Arbitration Flowchart for Single Request

State changes occur on the next rising edge of CLKOUT after the internal signal is valid. The \overline{BG} signal transitions on the falling edge of the clock after a state is reached during which G changes. The bus control signals (controlled by T) are driven by the MCU immediately following a state change, when bus mastership is returned to the MCU. State 0, in which G and T are both negated, is the state of the bus arbiter while the MCU is bus master. Request R and acknowledge A keep the arbiter in state 0 as long as they are both negated.

4.5.6.1 Slave (Factory Test) Mode Arbitration

This mode is used for factory production testing of internal modules. It is not supported as a user operating mode. Slave mode is enabled by holding DATA11 low during reset. In slave mode, when \overline{BG} is asserted, the MCU is slaved to an external master that has full access to all internal registers.

4.5.6.2 Show Cycles

The MCU normally performs internal data transfers without affecting the external bus, but it is possible to show these transfers during debugging. \overline{AS} is not asserted externally during show cycles.

Show cycles are controlled by the SHEN field in the SIMCR (refer to **4.2.3 Show Internal Cycles**). This field is cleared by reset. When show cycles are disabled, the address bus, function codes, size, and read/write signals reflect internal bus activity, but \overline{AS} and \overline{DS} are not asserted externally and external data bus pins are in high-impedance state during internal accesses.

When show cycles are enabled, \overline{DS} is asserted externally during internal cycles, and internal data is driven out on the external data bus. Because internal cycles normally continue to run when the external bus is granted, one SHEN encoding halts internal bus activity while there is an external master.

SIZ[1:0] signals reflect bus allocation during show cycles. Only the appropriate portion of the data bus is valid during the cycle. During a byte write to an internal address, the portion of the bus that represents the byte that is not written reflects internal bus conditions, and is indeterminate. During a byte write to an external address, the data multiplexer in the SIM causes the value of the byte that is written to be driven out on both bytes of the data bus.

4.6 Reset

Reset occurs when an active low logic level on the \overline{RESET} pin is clocked into the SIM. The \overline{RESET} input is synchronized to the system clock. If there is no clock when \overline{RESET} is asserted, reset does not occur until the clock starts. Resets are clocked to allow completion of write cycles in progress at the time \overline{RESET} is asserted.

Reset procedures handle system initialization and recovery from catastrophic failure. The MCU performs resets with a combination of hardware and software. The system integration module determines whether a reset is valid, asserts control signals, performs basic system configuration and boot ROM selection based on hardware mode-select inputs, then passes control to the CPU32.

4.6.1 Reset Exception Processing

The CPU32 processes resets as a type of asynchronous exception. An exception is an event that preempts normal processing, and can be caused by internal or external events. Exception processing makes the transition from normal instruction execution to execution of a routine that deals with an exception. Each exception has an assigned vector that points to an associated handler routine. These vectors are stored in the vector base register (VBR). The VBR contains the base address of a 1024-byte exception vector table, which consists of 256 exception vectors. The CPU32 uses vector numbers to calculate displacement into the table. Refer to **SECTION 5 CENTRAL PROCESSING UNIT** for more information concerning exceptions.

Reset is the highest-priority CPU32 exception. Unlike all other exceptions, a reset occurs at the end of a bus cycle, and not at an instruction boundary. Handling resets in this way prevents write cycles in progress at the time the reset signal is asserted from being corrupted. However, any processing in progress is aborted by the reset exception, and cannot be restarted. Only essential reset tasks are performed during exception processing. Other initialization tasks must be accomplished by the exception handler routine. **4.6.8 Reset Processing Summary** contains details of exception processing.

4.6.2 Reset Control Logic

SIM reset control logic determines the cause of a reset, synchronizes reset assertion if necessary to the completion of the current bus cycle, and asserts the appropriate reset lines. Reset control logic can drive four different internal signals.

1. EXTRST (external reset) drives the external reset pin.
2. CLKRST (clock reset) resets the clock module.
3. MSTRST (master reset) goes to all other internal circuits.
4. SYSRST (system reset) indicates to internal circuits that the CPU has executed a RESET instruction.

All resets are gated by CLKOUT. Resets are classified as synchronous or asynchronous. An asynchronous reset can occur on any CLKOUT edge. Reset sources that cause an asynchronous reset usually indicate a catastrophic failure; thus the reset control logic responds by asserting reset to the system immediately. (A system reset, however, caused by the CPU32 RESET instruction, is asynchronous but does not indicate any type of catastrophic failure).

Synchronous resets are timed (CLKOUT) to occur at the end of bus cycles. The internal bus monitor is automatically enabled for synchronous resets. When a bus cycle does not terminate normally, the bus monitor terminates it.

Refer to **Table 4-15** for a summary of reset sources.

Table 4-15 Reset Source Summary

Type	Source	Timing	Cause	Reset Lines Asserted by Controller		
External	External	Synch	External Signal	MSTRST	CLKRST	EXTRST
Power Up	EBI	Asynch	V _{DD}	MSTRST	CLKRST	EXTRST
Software Watchdog	Monitor	Asynch	Time Out	MSTRST	CLKRST	EXTRST
$\overline{\text{HALT}}$	Monitor	Asynch	Internal $\overline{\text{HALT}}$ Assertion (e.g. Double Bus Fault)	MSTRST	CLKRST	EXTRST
Loss of Clock	Clock	Synch	Loss of Reference	MSTRST	CLKRST	EXTRST
Test	Test	Synch	Test Mode	MSTRST	—	EXTRST
System	CPU32	Asynch	RESET Instruction	—	—	EXTRST

Internal single byte or aligned word writes are guaranteed valid for synchronous resets. External writes are also guaranteed to complete, provided the external configuration logic on the data bus is conditioned as shown in **Figure 4-15**.

4.6.3 Reset Mode Selection

The logic states of certain data bus pins during reset determine SIM operating configuration. In addition, the state of the MODCLK pin determines system clock source and the state of the $\overline{\text{BKPT}}$ pin determines what happens during subsequent breakpoint assertions. **Table 4-16** is a summary of reset mode selection options.

Table 4-16 Reset Mode Selection

Mode Select Pin	Default Function (Pin Left High)	Alternate Function (Pin Pulled Low)
DATA0	CSBOOT 16-Bit	CSBOOT 8-Bit
DATA1	$\overline{CS0}$ $\overline{CS1}$ $\overline{CS2}$	\overline{BR} \overline{BG} \overline{BGACK}
DATA2	$\overline{CS3}$ $\overline{CS4}$ $\overline{CS5}$	FC0 FC1 FC2
DATA3 DATA4 DATA5 DATA6 DATA7	$\overline{CS6}$ $\overline{CS[7:6]}$ $\overline{CS[8:6]}$ $\overline{CS[9:6]}$ $\overline{CS[10:6]}$	ADDR19 ADDR[20:19] ADDR[21:19] ADDR[22:19] ADDR[23:19]
DATA8	$\overline{DSACK[1:0]}$, AVEC, DS, AS, SIZE	PORTE
DATA9	$\overline{IRQ[7:1]}$ MODCLK	PORTF
DATA11	Test Mode Disabled	Test Mode Enabled
MODCLK	VCO = System Clock	EXTAL = System Clock
\overline{BKPT}	Background Mode Disabled	Background Mode Enabled

4.6.3.1 Data Bus Mode Selection

All data lines have weak internal pull-up drivers. When pins are held high by the internal drivers, the MCU uses a default operating configuration. However, specific lines can be held low externally to achieve an alternate configuration.

NOTE

External bus loading can overcome the weak internal pull-up drivers on data bus lines, and hold pins low during reset.

Use an active device to hold data bus lines low. Data bus configuration logic must release the bus before the first bus cycle after reset to prevent conflict with external memory devices. The first bus cycle occurs ten CLKOUT cycles after \overline{RESET} is released. If external mode selection logic causes a conflict of this type, an isolation resistor on the driven lines may be required. **Figure 4-15** shows a recommended method for conditioning the mode select signals.

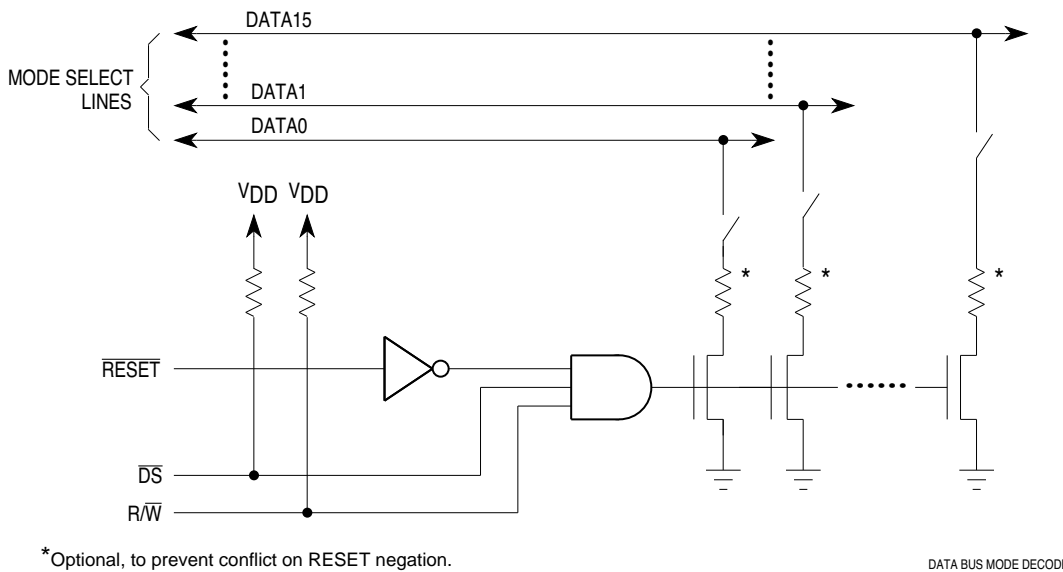

Figure 4-15 Data Bus Mode Select Conditioning

Data bus mode select current is specified in **APPENDIX A ELECTRICAL CHARACTERISTICS**. Do not confuse pin function with pin electrical state. Refer to **4.6.5 Pin State During Reset** for more information.

DATA0 determines the function of the boot ROM chip-select signal (\overline{CSBOOT}). Unlike other chip-select signals, \overline{CSBOOT} is active at the release of reset. During reset exception processing, the MCU fetches initialization vectors beginning at address \$000000 in supervisor program space. An external memory device containing vectors located at these addresses can be enabled by \overline{CSBOOT} after a reset. The logic level of DATA0 during reset selects boot ROM port size for dynamic bus allocation. When DATA0 is held low, port size is eight bits; when DATA0 is held high, either by the weak internal pull-up driver or by an external pull-up, port size is 16 bits. Refer to **4.8.4 Chip-Select Reset Operation** for more information.

DATA1 and DATA2 determine the functions of $\overline{CS[2:0]}$ and $\overline{CS[5:3]}$, respectively. DATA[7:3] determine the functions of an associated chip select and all lower-numbered chip-selects down through $\overline{CS6}$. For example, if DATA5 is pulled low during reset, $\overline{CS[8:6]}$ are assigned alternate function as ADDR[21:19], and $\overline{CS[10:9]}$ remain chip-selects. Refer to **4.8.4 Chip-Select Reset Operation** for more information.

DATA8 determines the function of the $\overline{DSACK[1:0]}$, \overline{AVEC} , \overline{DS} , \overline{AS} , and SIZE pins. If DATA8 is held low during reset, these pins are assigned to I/O port E.

DATA9 determines the function of interrupt request pins $\overline{IRQ[7:0]}$ and the clock mode select pin (MODCLK). When DATA9 is held low during reset, these pins are assigned to I/O port F.

DATA11 determines whether the SIM operates in test mode out of reset. This capability is used for factory testing of the MCU.

4.6.3.2 Clock Mode Selection

The state of the clock mode (MODCLK) pin during reset determines what clock source the MCU uses. When MODCLK is held high during reset, the clock signal is generated from a reference frequency. When MODCLK is held low during reset, the clock synthesizer is disabled, and an external system clock signal must be applied. Refer to **4.3 System Clock** for more information.

NOTE

The MODCLK pin can also be used as parallel I/O pin PF0. To prevent inadvertent clock mode selection by logic connected to port F, use an active device to drive MODCLK during reset.

4.6.3.3 Breakpoint Mode Selection

The MCU uses internal and external breakpoint ($\overline{\text{BKPT}}$) signals. During reset exception processing, at the release of the $\overline{\text{RESET}}$ signal, the CPU32 samples these signals to determine how to handle breakpoints.

If either $\overline{\text{BKPT}}$ signal is at logic level zero when sampled, an internal BDM flag is set, and the CPU32 enters background debugging mode whenever either $\overline{\text{BKPT}}$ input is subsequently asserted.

If both $\overline{\text{BKPT}}$ inputs are at logic level one when sampled, breakpoint exception processing begins whenever either $\overline{\text{BKPT}}$ signal is subsequently asserted.

Refer to **SECTION 5 CENTRAL PROCESSING UNIT** for more information on background debugging mode and exceptions. Refer to **4.5.4 CPU Space Cycles** for information concerning breakpoint acknowledge bus cycles.

4.6.4 MCU Module Pin Function During Reset

Usually, module pins default to port functions, and input/output ports are set to input state. This is accomplished by disabling pin functions in the appropriate control registers, and by clearing the appropriate port data direction registers. Refer to individual module sections in this manual for more information. **Table 4-17** is a summary of module pin function out of reset. Refer to **APPENDIX D REGISTER SUMMARY** for register function and reset state.

Table 4-17 Module Pin Functions

Module	Pin Mnemonic	Function
CPU32	DSI/IFETCH	DSI/IFETCH
	DSO/IPIPE	DSO/IPIPE
	BKPT/DSCLK	BKPT/DSCLK
GPT	PGP7/IC4/OC5	Discrete Input
	PGP[6:3]/OC[4:1]	Discrete Input
	PGP[2:0]/IC[3:1]	Discrete Input
	PAI	Discrete Input
	PCLK	Discrete Input
	PWMA, PWMB	Discrete Output
QSM	PQS7/TXD	Discrete Input
	PQS[6:4]/PCS[3:1]	Discrete Input
	PQS3/PCS0/SS	Discrete Input
	PQS2/SCK	Discrete Input
	PQS1/MOSI	Discrete Input
	PQS0/MISO	Discrete Input
	RXD	RXD

4.6.5 Pin State During Reset

It is important to keep the distinction between pin function and pin electrical state clear. Although control register values and mode select inputs determine pin function, a pin driver can be active, inactive or in high-impedance state while reset occurs. During power-up reset, pin state is subject to the constraints discussed in **4.6.7 Power-On Reset**.

NOTE

Pins that are not used should either be configured as outputs, or (if configured as inputs) pulled to the appropriate inactive state. This decreases additional I_{DD} caused by digital inputs floating near mid-supply level.

4.6.5.1 Reset States of SIM Pins

Generally, while $\overline{\text{RESET}}$ is asserted, SIM pins either go to an inactive high-impedance state or are driven to their inactive states. After $\overline{\text{RESET}}$ is released, mode selection occurs, and reset exception processing begins. Pins configured as inputs during reset become active high-impedance loads after $\overline{\text{RESET}}$ is released. Inputs must be driven to the desired active state. Pull-up or pull-down circuitry may be necessary. Pins configured as outputs begin to function after $\overline{\text{RESET}}$ is released. **Table 4-18** is a summary of SIM pin states during reset.

Table 4-18 SIM Pin Reset States

Mnemonic	State While RESET Asserted	Pin State After RESET Released			
		Pin Function	Pin State	Pin Function	Pin State
CS10/ADDR23	1	CS10	1	ADDR23	Unknown
CS[9:6]/ADDR[22:19]/PC[6:3]	1	CS[9:6]	1	ADDR[22:19]	Unknown
ADDR[18:0]	High-Z Output	ADDR[18:0]	Unknown	ADDR[18:0]	Unknown
AS/PE5	High-Z Output	AS	Output	PE5	Input
AVEC/PE2	Disabled	AVEC	Input	PE2	Input
BERR	Disabled	BERR	Input	BERR	Input
CSM/BG	1	CSM	1	BG	1
CSE/BGACK	1	CSE	1	BGACK	Input
CS0/BR	1	CS0	1	BR	Input
CLKOUT	Output	CLKOUT	Output	CLKOUT	Output
CSBOOT	1	CSBOOT	0	CSBOOT	0
DATA[15:0]	Mode Select	DATA[15:0]	Input	DATA[15:0]	Input
DS/PE4	Disabled	DS	Output	PE4	Input
DSACK0/PE0	Disabled	DSACK0	Input	PE0	Input
DSACK1/PE1	Disabled	DSACK1	Input	PE1	Input
CS5/FC2/PC2	1	CS5	1	FC2	Unknown
FC1/PC1	1	FC1	1	FC1	Unknown
CS3/FC0/PC0	1	CS3	1	FC0	Unknown
HALT	Disabled	HALT	Input	HALT	Input
IRQ[7:1]/PF[7:1]	Disabled	IRQ[7:1]	Input	PF[7:1]	Input
MODCLK/PF0	Mode Select	MODCLK	Input	PF0	Input
R/W	Disabled	R/W	Output	R/W	Output
RESET	Asserted	RESET	Input	RESET	Input
RMC	Disabled	RMC	Output	PE3	Input
SIZ[1:0]/PE[7:6]	Disabled	SIZ[1:0]	Unknown	PE[7:6]	Input
TSC	Mode Select	TSC	Input	TSC	Input

4.6.5.2 Reset States of Pins Assigned to Other MCU Modules

As a rule, module pins that are assigned to general-purpose I/O ports go to active high-impedance state following reset. Other pin states are determined by individual module control register settings. Refer to sections concerning modules for details. However, during power-up reset, module port pins may be in an indeterminate state for a short period. Refer to **4.6.7 Power-On Reset** for more information.

4.6.6 Reset Timing

The RESET input must be asserted for a specified minimum period for reset to occur. External RESET assertion can be delayed internally for a period equal to the longest bus cycle time (or the bus monitor time-out period) in order to protect write cycles from being aborted by reset. While RESET is asserted, SIM pins are either in an inactive, high impedance state or are driven to their inactive states.

When an external device asserts RESET for the proper period, reset control logic clocks the signal into an internal latch. The control logic drives the RESET pin low for an additional 512 CLKOUT cycles after it detects that the RESET signal is no longer being externally driven, to guarantee this length of reset to the entire system.

If an internal source asserts a reset signal, the reset control logic asserts $\overline{\text{RESET}}$ for a minimum of 512 cycles. If the reset signal is still asserted at the end of 512 cycles, the control logic continues to assert $\overline{\text{RESET}}$ until the internal reset signal is negated.

After 512 cycles have elapsed, the reset input pin goes to an inactive, high-impedance state for ten cycles. At the end of this 10-cycle period, the reset input is tested. When the input is at logic level one, reset exception processing begins. If, however, the reset input is at logic level zero, the reset control logic drives the pin low for another 512 cycles. At the end of this period, the pin again goes to high-impedance state for ten cycles, then it is tested again. The process repeats until $\overline{\text{RESET}}$ is released.

4.6.7 Power-On Reset

When the SIM clock synthesizer is used to generate system clocks, power-on reset involves special circumstances related to application of system and clock synthesizer power. Regardless of clock source, voltage must be applied to clock synthesizer power input pin V_{DDSYN} for the MCU to operate. The following discussion assumes that V_{DDSYN} is applied before and during reset, which minimizes crystal start-up time. When V_{DDSYN} is applied at power-on, start-up time is affected by specific crystal parameters and by oscillator circuit design. V_{DD} ramp-up time also affects pin state during reset. Refer to **APPENDIX A ELECTRICAL CHARACTERISTICS** for voltage and timing specifications.

During power-on reset, an internal circuit in the SIM drives the IMB internal (MSTRST) and external (EXTRST) reset lines. The circuit releases MSTRST as V_{DD} ramps up to the minimum specified value, and SIM pins are initialized as shown in **Table 4-19**. As V_{DD} reaches specified minimum value, the clock synthesizer VCO begins operation and clock frequency ramps up to specified limp mode frequency. The external $\overline{\text{RESET}}$ line remains asserted until the clock synthesizer PLL locks and 512 CLKOUT cycles elapse.

The SIM clock synthesizer provides clock signals to the other MCU modules. After the clock is running and MSTRST is asserted for at least four clock cycles, these modules reset. V_{DD} ramp time and VCO frequency ramp time determine how long the four cycles take. Worst case is approximately 15 milliseconds. During this period, module port pins may be in an indeterminate state. While input-only pins can be put in a known state by external pull-up resistors, external logic on input/output or output-only pins during this time must condition the lines. Active drivers require high-impedance buffers or isolation resistors to prevent conflict.

Figure 4-16 is a timing diagram of power-up reset. It shows the relationships between $\overline{\text{RESET}}$, V_{DD} , and bus signals.

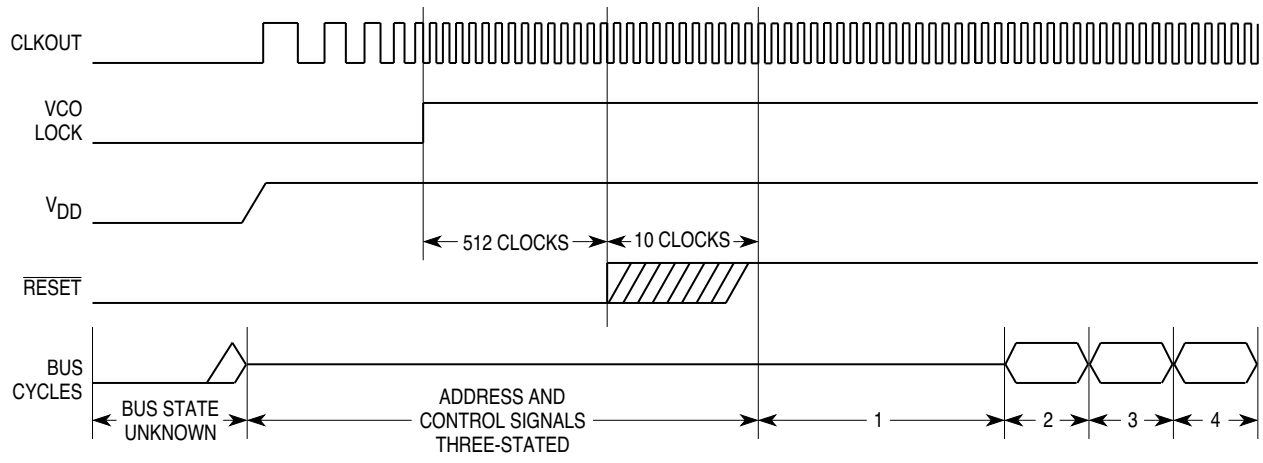

- NOTES:
1. Internal start-up time.
 2. SSP fetched.
 3. PC fetched.
 4. First instruction fetched.

32 POR TIM

Figure 4-16 Power-On Reset

4.6.8 Reset Processing Summary

To prevent write cycles in progress from being corrupted, a reset is recognized at the end of a bus cycle, and not at an instruction boundary. Any processing in progress at the time a reset occurs is aborted. After SIM reset control logic has synchronized an internal or external reset request, it asserts the MSTRST signal.

The following events take place when MSTRST is asserted.

- A. Instruction execution is aborted.
- B. The status register is initialized.
 1. The T0 and T1 bits are cleared to disable tracing.
 2. The S bit is set to establish supervisor privilege level.
 3. The interrupt priority mask is set to \$7, disabling all interrupts below priority 7.
- C. The vector base register is initialized to \$000000.

The following events take place when MSTRST is negated after assertion.

- A. The CPU32 samples the $\overline{\text{BKPT}}$ input.
- B. The CPU32 fetches the reset vector:
 1. The first long word of the vector is loaded into the interrupt stack pointer.
 2. The second long word of the vector is loaded into the program counter.

Vectors can be fetched from internal RAM or from external ROM enabled by the $\overline{\text{CSBOOT}}$ signal.
- C. The CPU32 fetches and begins decoding the first instruction to be executed.

4.6.9 Reset Status Register

The reset status register (RSR) contains a bit for each reset source in the MCU. When a reset occurs, a bit corresponding to the reset type is set. When multiple causes of reset occur at the same time, more than one bit in RSR may be set. The reset status register is updated by the reset control logic when the $\overline{\text{RESET}}$ signal is released. Refer to **APPENDIX D REGISTER SUMMARY**.

4.7 Interrupts

Interrupt recognition and servicing involve complex interaction between the system integration module, the central processing unit, and a device or module requesting interrupt service. This discussion provides an overview of the entire interrupt process. Chip-select logic can also be used to respond to interrupt requests. Refer to **4.8 Chip Selects** for more information.

4.7.1 Interrupt Exception Processing

The CPU32 processes resets as a type of asynchronous exception. An exception is an event that preempts normal processing. Each exception has an assigned vector in an exception vector table that points to an associated handler routine. The CPU uses vector numbers to calculate displacement into the table. During exception processing, the CPU fetches the appropriate vector and executes the exception handler routine to which the vector points.

Out of reset, the exception vector table is located beginning at address \$000000. This value can be changed by programming the vector base register (VBR) with a new value, and multiple vector tables can be used. Refer to **SECTION 5 CENTRAL PROCESSING UNIT** for more information concerning exceptions.

4.7.2 Interrupt Priority and Recognition

The CPU32 provides eight levels of interrupt priority. All interrupts with priorities less than seven can be masked by the interrupt priority (IP) field in status register.

There are seven interrupt request signals ($\overline{\text{IRQ}}[7:1]$). These signals are used internally on the IMB, and are corresponding pins for external interrupt service requests. The CPU treats all interrupt requests as though they come from internal modules — external interrupt requests are treated as interrupt service requests from the SIM. Each of the interrupt request signals corresponds to an interrupt priority level. $\overline{\text{IRQ}}1$ has the lowest priority and $\overline{\text{IRQ}}7$ the highest.

Interrupt recognition is determined by interrupt priority level and interrupt priority mask value, interrupt recognition is determined by interrupt priority level and interrupt priority mask value. The interrupt priority mask consists of three bits in the CPU32 status register. Binary values %000 to %111 provide eight priority masks. Masks prevent an interrupt request of a priority less than or equal to the mask value from being recognized and processed. $\overline{\text{IRQ}}7$, however, is always recognized, even if the mask value is %111.

$\overline{\text{IRQ}}[7:1]$ are active-low level-sensitive inputs. The low on the pin must remain asserted until an interrupt acknowledge cycle corresponding to that level is detected.

$\overline{\text{IRQ7}}$ is transition-sensitive as well as level-sensitive: a level-7 interrupt is not detected unless a falling edge transition is detected on the $\overline{\text{IRQ7}}$ line. This prevents redundant servicing and stack overflow. A nonmaskable interrupt is generated each time $\overline{\text{IRQ7}}$ is asserted as well as each time the priority mask changes from %111 to a lower number while $\overline{\text{IRQ7}}$ is asserted.

Interrupt requests are sampled on consecutive falling edges of the system clock. Interrupt request input circuitry has hysteresis: to be valid, a request signal must be asserted for at least two consecutive clock periods. Valid requests do not cause immediate exception processing, but are left pending. Pending requests are processed at instruction boundaries or when exception processing of higher-priority exceptions is complete.

The CPU32 does not latch the priority of a pending interrupt request. If an interrupt source of higher priority makes a service request while a lower priority request is pending, the higher priority request is serviced. If an interrupt request with a priority equal to or lower than the current IP mask value is made, the CPU32 does not recognize the occurrence of the request. If simultaneous interrupt requests of different priorities are made, and both have a priority greater than the mask value, the CPU32 recognizes the higher-level request.

4.7.3 Interrupt Acknowledge and Arbitration

When the CPU32 detects one or more interrupt requests of a priority higher than the interrupt priority mask value, it places the interrupt request level on the address bus and initiates a CPU space read cycle. The request level serves two purposes: it is decoded by modules or external devices that have requested interrupt service, to determine whether the current interrupt acknowledge cycle pertains to them, and it is latched into the interrupt priority mask field in the CPU32 status register, to preclude further interrupts of lower priority during interrupt service.

Modules or external devices that have requested interrupt service must decode the interrupt priority mask value placed on the address bus during the interrupt acknowledge cycle and respond if the priority of the service request corresponds to the mask value. However, before modules or external devices respond, interrupt arbitration takes place.

Arbitration is performed by means of serial contention between values stored in individual module interrupt arbitration (IARB) fields. Each module that can make an interrupt service request, including the SIM, has an IARB field in its configuration register. IARB fields can be assigned values from %0000 to %1111. In order to implement an arbitration scheme, each module that can initiate an interrupt service request must be assigned a unique, non-zero IARB field value during system initialization. Arbitration priorities range from %0001 (lowest) to %1111 (highest) — if the CPU recognizes an interrupt service request from a source that has an IARB field value of %0000, a spurious interrupt exception is processed.

WARNING

Do not assign the same arbitration priority to more than one module. When two or more IARB fields have the same nonzero value, the

CPU32 interprets multiple vector numbers at the same time, with unpredictable consequences.

Because the EBI manages external interrupt requests, the SIM IARB value is used for arbitration between internal and external interrupt requests. The reset value of IARB for the SIM is %1111, and the reset IARB value for all other modules is %0000.

Although arbitration is intended to deal with simultaneous requests of the same priority, it always takes place, even when a single source is requesting service. This is important for two reasons: the EBI does not transfer the interrupt acknowledge read cycle to the external bus unless the SIM wins contention, and failure to contend causes the interrupt acknowledge bus cycle to be terminated early, by a bus error.

When arbitration is complete, the module with the highest arbitration priority must terminate the bus cycle. Internal modules place an interrupt vector number on the data bus and generate appropriate internal cycle termination signals. In the case of an external interrupt request, after the interrupt acknowledge cycle is transferred to the external bus, the appropriate external device must decode the mask value and respond with a vector number, then generate data and size acknowledge (\overline{DSACK}) termination signals, or it must assert the autovector (\overline{AVEC}) request signal. If the device does not respond in time, the EBI bus monitor asserts the bus error signal \overline{BERR} , and a spurious interrupt exception is taken.

Chip-select logic can also be used to generate internal \overline{AVEC} or \overline{DSACK} signals in response to interrupt requests from external devices (refer to **4.8.3 Using Chip-Select Signals for Interrupt Acknowledge**). Chip-select address match logic functions only after the EBI transfers an interrupt acknowledge cycle to the external bus following IARB contention. If a module makes an interrupt request of a certain priority, and the appropriate chip-select registers are programmed to generate \overline{AVEC} or \overline{DSACK} signals in response to an interrupt acknowledge cycle for that priority level, chip-select logic does not respond to the interrupt acknowledge cycle, and the internal module supplies a vector number and generates internal cycle termination signals.

For periodic timer interrupts, the PIRQ field in the periodic interrupt control register (PI-CR) determines PIT priority level. A PIRQ value of %000 means that PIT interrupts are inactive. By hardware convention, when the CPU32 receives simultaneous interrupt requests of the same level from more than one SIM source (including external devices), the periodic interrupt timer is given the highest priority, followed by the \overline{IRQ} pins.

4.7.4 Interrupt Processing Summary

A summary of the entire interrupt processing sequence follows. When the sequence begins, a valid interrupt service request has been detected and is pending.

- A. The CPU finishes higher priority exception processing or reaches an instruction boundary.
- B. The processor state is stacked. The S bit in the status register is set, establishing supervisor access level, and bits T1 and T0 are cleared, disabling tracing.
- C. The interrupt acknowledge cycle begins:
 1. FC[2:0] are driven to %111 (CPU space) encoding.

2. The address bus is driven as follows: ADDR[23:20] = %1111; ADDR[19:16] = %1111, which indicates that the cycle is an interrupt acknowledge CPU space cycle; ADDR[15:4] = %111111111111; ADDR[3:1] = the priority of the interrupt request being acknowledged; and ADDR0 = %1.
 3. The request level is latched from the address bus into the interrupt priority mask field in the status or condition code register.
- D. Modules that have requested interrupt service decode the priority value in ADDR[3:1]. If request priority is the same as acknowledged priority, arbitration by IARB contention takes place.
- E. After arbitration, the interrupt acknowledge cycle is completed in one of the following ways:
1. When there is no contention (IARB = %0000), the spurious interrupt monitor asserts $\overline{\text{BERR}}$, and the CPU generates the spurious interrupt vector number.
 2. The dominant interrupt source supplies a vector number and $\overline{\text{DSACK}}$ signals appropriate to the access. The CPU acquires the vector number.
 3. The $\overline{\text{AVEC}}$ signal is asserted (the signal can be asserted by the dominant interrupt source or the pin can be tied low), and the CPU generates an autovector number corresponding to interrupt priority.
 4. The bus monitor asserts $\overline{\text{BERR}}$ and the CPU32 generates the spurious interrupt vector number.
- F. The vector number is converted to a vector address.
- G. The content of the vector address is loaded into the PC, and the processor transfers control to the exception handler routine.

4.7.5 Interrupt Acknowledge Bus Cycles

Interrupt acknowledge bus cycles are CPU32 space cycles that are generated during exception processing. For further information about the types of interrupt acknowledge bus cycles determined by $\overline{\text{AVEC}}$ or $\overline{\text{DSACK}}$, refer to **APPENDIX A ELECTRICAL CHARACTERISTICS** and the *SIM Reference Manual* (SIMRM/AD).

4.8 Chip Selects

Typical microcontrollers require additional hardware to provide external select and address decode signals. The MCU includes 12 programmable chip-select circuits that can provide 2- to 20-clock-cycle access to external memory and peripherals. Address block sizes of two Kbytes to one Mbyte can be selected. **Figure 4-17** is a diagram of a basic system that uses chip selects.

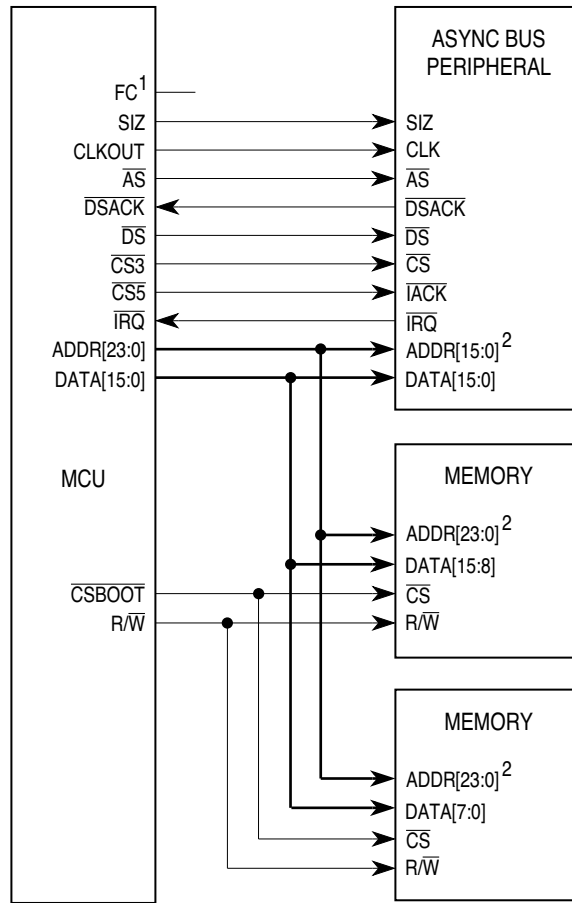

1. Can be decoded to provide additional address space.
2. Varies depending upon peripheral memory size.

32 EXAMPLE SYS BLOCK

4

Figure 4-17 Basic MCU System

Chip-select assertion can be synchronized with bus control signals to provide output enable, read/write strobe, or interrupt acknowledge signals. Chip select logic can also generate \overline{DSACK} and \overline{AVEC} signals internally. Each signal can also be synchronized with the ECLK signal available on ADDR23.

When a memory access occurs, chip-select logic compares address space type, address, type of access, transfer size, and interrupt priority (in the case of interrupt acknowledge) to parameters stored in chip-select registers. If all parameters match, the appropriate chip-select signal is asserted. Select signals are active low. If a chip-select function is given the same address as a microcontroller module or an internal memory array, an access to that address goes to the module or array, and the chip-select signal is not asserted. The external address and data buses do not reflect the internal access.

All chip-select circuits are configured for operation out of reset. However, all chip-select signals except \overline{CSBOOT} are disabled, and cannot be asserted until the BYTE field in the corresponding option register is programmed to a nonzero value, selecting a

transfer size. The chip-select option must not be written until a base address has been written to a proper base address register. CSBOOT is automatically asserted out of reset. Alternate functions for chip-select pins are enabled if appropriate data bus pins are held low at the release of the reset signal (refer to **4.6.3.1 Data Bus Mode Selection** for more information). **Figure 4-18** is a functional diagram of a single chip-select circuit.

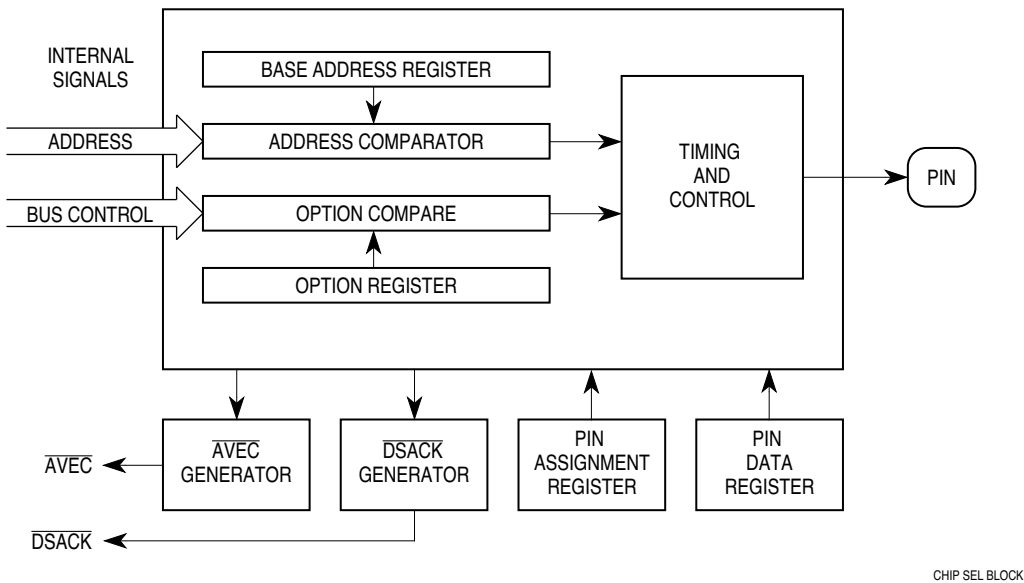

Figure 4-18 Chip-Select Circuit Block Diagram

4.8.1 Chip-Select Registers

Each chip-select pin can have one or more functions. Chip-select pin assignment registers (CSPAR[0:1]) determine functions of the pins. Pin assignment registers also determine port size (8- or 16-bit) for dynamic bus allocation. A pin data register (PORTC) latches data for chip-select pins that are used for discrete output.

Blocks of addresses are assigned to each chip-select function. Block sizes of two Kbytes to one Mbyte can be selected by writing values to the appropriate base address register (CSBAR[0:10], CSBARBT). Address blocks for separate chip-select functions can overlap.

Chip select option registers (CSOR[0:10], CSORBT) determine timing of and conditions for assertion of chip-select signals. Eight parameters, including operating mode, access size, synchronization, and wait state insertion can be specified.

Initialization software usually resides in a peripheral memory device controlled by the chip-select circuits. A set of special chip-select functions and registers (CSORBT, CSBARBT) is provided to support bootstrap operation.

Comprehensive address maps and register diagrams are provided in **APPENDIX D REGISTER SUMMARY**.

4.8.1.1 Chip-Select Pin Assignment Registers

The pin assignment registers contain twelve 2-bit fields ($\overline{CS}[10:0]$ and \overline{CSBOOT}) that determine the functions of the chip-select pins. Each pin has two or three possible functions, as shown in **Table 4-19**.

Table 4-19 Chip-Select Pin Functions

16-Bit Chip Select	8-Bit Chip Select	Alternate Function	Discrete Output
\overline{CSBOOT}	\overline{CSBOOT}	\overline{CSBOOT}	—
$\overline{CS0}$	$\overline{CS0}$	BR	—
$\overline{CS1}$	$\overline{CS1}$	BG	—
$\overline{CS2}$	$\overline{CS2}$	BGACK	—
$\overline{CS3}$	$\overline{CS3}$	FC0	PC0
$\overline{CS4}$	$\overline{CS4}$	FC1	PC1
$\overline{CS5}$	$\overline{CS5}$	FC2	PC2
$\overline{CS6}$	$\overline{CS6}$	ADDR19	PC3
$\overline{CS7}$	$\overline{CS7}$	ADDR20	PC4
$\overline{CS8}$	$\overline{CS8}$	ADDR21	PC5
$\overline{CS9}$	$\overline{CS9}$	ADDR22	PC6
$\overline{CS10}$	$\overline{CS10}$	ADDR23	ECLK

Table 4-20 shows pin assignment field encoding. Pins that have no discrete output function do not use the %00 encoding.

Table 4-20 Pin Assignment Field Encoding

Bit Field	Description
00	Discrete Output
01	Alternate Function
10	Chip Select (8-Bit Port)
11	Chip Select (16-Bit Port)

Port size determines the way in which bus transfers to an external address are allocated. Port size of eight bits or sixteen bits can be selected when a pin is assigned as a chip select. Port size and transfer size affect how the chip-select signal is asserted. Refer to **4.8.1.3 Chip-Select Option Registers** for more information.

Out of reset, chip-select pin function is determined by the logic level on a corresponding data bus pin. These pins have weak internal pull-up drivers, but can be held low by external devices. (Refer to **4.6.3.1 Data Bus Mode Selection** for more information.) Either 16-bit chip-select function (%11) or alternate function (%01) can be selected during reset. All pins except the boot ROM select pin (\overline{CSBOOT}) are disabled out of reset. There are twelve chip-select functions and only eight associated data bus pins. There is not a one-to-one correspondence. Refer to **4.8.4 Chip-Select Reset Operation** for more detailed information.

The \overline{CSBOOT} signal is normally enabled out of reset. The state of the DATA0 line during reset determines what port width \overline{CSBOOT} uses. If DATA0 is held high (either by the weak internal pull-up driver or by an external pull-up device), 16-bit width is selected. If DATA0 is held low, 8-bit port size is selected.

A pin programmed as a discrete output drives an external signal to the value specified in the pin data register. No discrete output function is available on pins \overline{CSBOOT} , \overline{BR} , \overline{BG} , or \overline{BGACK} . ADDR23 provides ECLK output rather than a discrete output signal.

When a pin is programmed for discrete output or alternate function, internal chip-select logic still functions and can be used to generate \overline{DSACK} or \overline{AVEC} internally on an address and control signal match.

4.8.1.2 Chip-Select Base Address Registers

Each chip select has an associated base address register. A base address is the lowest address in the block of addresses enabled by a chip select. Block size is the extent of the address block above the base address. Block size is determined by the value contained in a BLKSZ field. Block addresses for different chip selects can overlap.

The BLKSZ field determines which bits in the base address field are compared to corresponding bits on the address bus during an access. Provided other constraints determined by option register fields are also satisfied, when a match occurs, the associated chip-select signal is asserted. **Table 4-21** shows BLKSZ encoding.

Table 4-21 Block Size Encoding

BLKSZ[2:0]	Block Size	Address Lines Compared
000	2 Kbyte	ADDR[23:11]
001	8 Kbyte	ADDR[23:13]
010	16 Kbyte	ADDR[23:14]
011	64 Kbyte	ADDR[23:16]
100	128 Kbyte	ADDR[23:17]
101	256 Kbyte	ADDR[23:18]
110	512 Kbyte	ADDR[23:19]
111	1 Mbyte	ADDR[23:20]

The chip-select address compare logic uses only the most significant bits to match an address within a block. The value of the base address must be a multiple of block size. Base address register diagrams show how base register bits correspond to address lines.

After reset, the MCU fetches the initialization routine from the address contained in the reset vector, located beginning at address \$000000 of program space. To support bootstrap operation from reset, the base address field in chip-select base address register boot (CSBARBT) has a reset value of all zeros. A memory device containing the reset vector and initialization routine can be automatically enabled by \overline{CSBOOT} after a reset. The block size field in CSBARBT has a reset value of 512 Kbytes. Refer to **4.8.4 Chip-Select Reset Operation** for more information.

4.8.1.3 Chip-Select Option Registers

Option register fields determine timing of and conditions for assertion of chip-select signals. To assert a chip-select signal, and to provide \overline{DSACK} or autovector support, other constraints set by fields in the option register and in the base address register must also be satisfied. **Table 4-22** is a summary of option register functions.

Table 4-22 Option Register Function Summary

MODE	BYTE	R/W	STRB	DSACK	SPACE	IPL	AVEC
0 = ASYNC*	00 = Disable	00 = Rsvd	0 = \overline{AS}	0000 = 0 WAIT	00 = CPU SP	000 = All*	0 = Off*
1 = SYNC	01 = Lower	01 = Read	1 = \overline{DS}	0001 = 1 WAIT	01 = User SP	001 = Priority 1	1 = On
	10 = Upper	10 = Write		0010 = 2 WAIT	10 = Supv SP	010 = Priority 2	
	11 = Both	11 = Both		0011 = 3 WAIT	11 = S/U SP	011 = Priority 3	
				0100 = 4 WAIT		100 = Priority 4	
				0101 = 5 WAIT		101 = Priority 5	
				0110 = 6 WAIT		110 = Priority 6	
				0111 = 7 WAIT		111 = Priority 7	
				1000 = 8 WAIT			
				1001 = 9 WAIT			
				1010 = 10 WAIT			
				1011 = 11 WAIT			
				1100 = 12 WAIT			
				1101 = 13 WAIT			
				1110 = F term			
				1111 = External			

*Use this value when function is not required for chip-select operation.

The **MODE** bit determines whether chip-select assertion simulates an asynchronous bus cycle, or is synchronized to the M6800-type bus clock signal (ECLK) available on ADDR23 (refer to **4.3 System Clock** for more information on ECLK).

The **BYTE** field controls bus allocation for chip-select transfers. Port size, set when a chip select is enabled by a pin assignment register, affects signal assertion. When an 8-bit port is assigned, any BYTE field value other than %00 enables the chip select signal. When a 16-bit port is assigned, however, BYTE field value determines when the chip select is enabled. The BYTE fields for $\overline{CS}[10:0]$ are cleared during reset. However, both bits in the boot ROM option register (CSORBT) BYTE field are set (%11) when the reset signal is released.

The **R/W** field causes a chip-select signal to be asserted only for a read, only for a write, or for both read and write. Use this field in conjunction with the STRB bit to generate asynchronous control signals for external devices.

The **STRB** bit controls the timing of a chip-select assertion in asynchronous mode. Selecting address strobe causes a chip-select signal to be asserted synchronized with the address strobe. Selecting data strobe causes a chip-select signal to be asserted synchronized with the data strobe. This bit has no effect in synchronous mode.

The **DSACK** field specifies the source of data strobe acknowledge signals used in asynchronous mode. It also allows the user to optimize bus speed in a particular application by controlling the number of wait states that are inserted.

The **SPACE** field determines the address space in which a chip select is asserted. An access must have the space type represented by SPACE encoding in order for a chip-select signal to be asserted.

The **IPL** field contains an interrupt priority mask that is used when chip-select logic is set to trigger on external interrupt acknowledge cycles. When the SPACE field is set

to %00 (CPU space), interrupt priority (ADDR[3:1]) is compared to IPL value. If the values are the same, and other option register constraints are satisfied, a chip select signal is asserted. This field only affects the response of chip selects and does not affect interrupt recognition by the CPU. Encoding %000 causes a chip-select signal to be asserted regardless of interrupt acknowledge cycle priority, provided all other constraints are met.

The $\overline{\text{AVEC}}$ bit selects one of two methods of acquiring an interrupt vector during an external interrupt acknowledge cycle. The internal autovector signal is generated only in response to interrupt requests from the SIM $\overline{\text{IRQ}}$ pins.

4.8.1.4 PORTC Data Register

The PORTC data register latches data for PORTC pins programmed as discrete outputs. When a pin is assigned as a discrete output, the value in this register appears at the output. PC[6:0] correspond to $\overline{\text{CS}}[9:3]$. Bit 7 is not used. Writing to this bit has no effect, and it always reads zero.

4.8.2 Chip-Select Operation

When the MCU makes an access, enabled chip-select circuits compare the following items:

1. Function codes to SPACE fields, and to the IPL field if the SPACE field encoding is not for CPU32 space.
2. Appropriate ADDR bits to base address fields.
3. Read/write status to R/ $\overline{\text{W}}$ fields.
4. ADDR0 and/or SIZ bits to the BYTE field (16-bit ports only).
5. Priority of the interrupt being acknowledged (ADDR[3:1]) to IPL fields (when the access is an interrupt acknowledge cycle).

When a match occurs, the chip-select signal is asserted. Assertion occurs at the same time as $\overline{\text{AS}}$ or $\overline{\text{DS}}$ assertion in asynchronous mode. Assertion is synchronized with ECLK in synchronous mode. In asynchronous mode, the value of the $\overline{\text{DSACK}}$ field determines whether $\overline{\text{DSACK}}$ is generated internally. $\overline{\text{DSACK}}$ also determines the number of wait states inserted before internal $\overline{\text{DSACK}}$ assertion.

The speed of an external device determines whether internal wait states are needed. Normally, wait states are inserted into the bus cycle during S3 until a peripheral asserts $\overline{\text{DSACK}}$. If a peripheral does not generate $\overline{\text{DSACK}}$, internal $\overline{\text{DSACK}}$ generation must be selected and a predetermined number of wait states can be programmed into the chip-select option register.

Refer to the *SIM Reference Manual* (SIMRM/AD) for further information.

4.8.3 Using Chip-Select Signals for Interrupt Acknowledge

Ordinary I/O bus cycles use supervisor space access, but interrupt acknowledge bus cycles use CPU space access. Refer to **4.5.4 CPU Space Cycles** for more information. There are no differences in flow for chip selects in each type of space, but base and option registers must be properly programmed for each type of external bus cycle.

During a CPU space cycle, bits [15:3] of the appropriate base register must be configured to match ADDR[23:11], as the address is compared to an address generated by the CPU.

Figure 4-19 shows CPU space encoding for an interrupt acknowledge cycle. FC[2:0] are set to %111, designating CPU space access. ADDR[3:1] indicate interrupt priority, and the space type field (ADDR[19:16]) is set to %1111, the interrupt acknowledge code. The rest of the address lines are set to one.

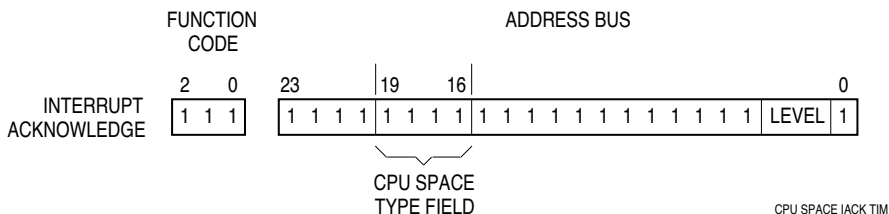

Figure 4-19 CPU Space Encoding for Interrupt Acknowledge

4

Because address match logic functions only after the EBI transfers an interrupt acknowledge cycle to the external address bus following IARB contention, chip-select logic generates \overline{AVEC} or \overline{DSACK} signals only in response to interrupt requests from external \overline{IRQ} pins. If an internal module makes an interrupt request of a certain priority, and the chip-select base address and option registers are programmed to generate \overline{AVEC} or \overline{DSACK} signals in response to an interrupt acknowledge cycle for that priority level, chip-select logic does not respond to the interrupt acknowledge cycle, and the internal module supplies a vector number and generates an internal \overline{DSACK} signal to terminate the cycle.

Perform the following operations before using a chip select to generate an interrupt acknowledge signal.

1. Program the base address field to all ones.
2. Program block size to no more than 64 Kbytes, so that the address comparator checks ADDR[19:16] against the corresponding bits in the base address register. (The CPU32 places the CPU32 space type on ADDR[19:16].)
3. Set the R/\overline{W} field to read only. An interrupt acknowledge cycle is performed as a read cycle.
4. Set the BYTE field to lower byte when using a 16-bit port, as the external vector for a 16-bit port is fetched from the lower byte. Set the BYTE field to upper byte when using an 8-bit port.

If an interrupting device does not provide a vector number, an autovector acknowledge must be generated. Asserting \overline{AVEC} , either by asserting the \overline{AVEC} pin or by generating \overline{AVEC} internally using the chip-select option register, terminates the bus cycle.

4.8.4 Chip-Select Reset Operation

The least significant bits of each of the 2-bit $\overline{CS}[10:0]$ pin assignment fields in CSPAR0 and CSPAR1 each have a reset value of one. The reset values of the most significant

bits of each field are determined by the states of DATA[7:1] during reset. There are weak internal pull-up drivers for each of the data lines, so that chip-select operation will be selected by default out of reset. However, the internal pull-up drivers can be overcome by bus loading effects — to insure a particular configuration out of reset, use an active device to put the data lines in a known state during reset. The base address fields in chip-select base address registers CSBAR[0:10] and chip select option registers CSOR[0:10] have the reset values shown in **Table 4-23**. The BYTE fields of CSOR[0:10] have a reset value of “disable”, so that a chip-select signal cannot be asserted until the base and option registers are initialized.

Table 4-23 Chip Select Base and Option Register Reset Values

Fields	Reset Values
Base Address	\$000000
Block Size	2 Kbyte
Async/Sync Mode	Asynchronous Mode
Upper/Lower Byte	Disabled
Read/Write	Reserved
$\overline{AS/DS}$	\overline{AS}
\overline{DSACK}	No Wait States
Address Space	CPU Space
IPL	Any Level
Autovector	External Interrupt Vector

Following reset, the MCU fetches initial stack pointer and program counter values from the exception vector table, beginning at \$000000 in supervisor program space. The \overline{CSBOOT} chip-select signal is used to select an external boot ROM mapped to a base address of \$000000. In order to do this, the reset values of the fields that control \overline{CSBOOT} must be different from those of other chip select signals.

The MSB of the \overline{CSBOOT} field in CSPAR0 has a reset value of one, so that chip-select function is selected by default out of reset. The BYTE field in option register CSORBT has a reset value of “both bytes” so that the select signal is enabled out of reset. The LSB value of the \overline{CSBOOT} field, determined by the logic level of DATA0 during reset, selects boot ROM port size. When DATA0 is held low during reset, port size is eight bits. When DATA0 is held high during reset, port size is 16 bits. DATA0 has a weak internal pull-up driver, so that a 16-bit port will be selected by default out of reset. However, the internal pull-up driver can be overcome by bus loading effects — to insure a particular configuration out of reset, use an active device to put DATA0 in a known state during reset.

The base address field in chip-select base address register boot (CSBARBT) has a reset value of all zeros, so that when the initial access to address \$000000 is made, an address match occurs, and the \overline{CSBOOT} signal is asserted. The block size field in CSBARBT has a reset value of 1 Mbyte. **Table 4-24** shows \overline{CSBOOT} reset values.

Table 4-24 CSBOOT Base and Option Register Reset Values

Fields	Reset Values
Base Address	\$000000
Block Size	1 Mbyte
Async/Sync Mode	Asynchronous Mode
Upper/Lower Byte	Both Bytes
Read/Write	Read/Write
$\overline{AS}/\overline{DS}$	\overline{AS}
\overline{DSACK}	13 Wait States
Address Space	Supervisor/User Space
IPL	Any Level
Autovector	Interrupt Vector Externally

4.9 Parallel Input/Output Ports

Fifteen SIM pins can be configured for general-purpose discrete input and output. Although these pins are organized into two ports, port E and port F, function assignment is by individual pin. Pin assignment registers, data direction registers, and data registers are used to implement discrete I/O.

4.9.1 Pin Assignment Registers

Bits in the port E and port F pin assignment registers (PEPAR and PFPAR) control the functions of the pins in each port. Any bit set to one defines the corresponding pin as a bus control signal. Any bit cleared to zero defines the corresponding pin as an I/O pin.

4.9.2 Data Direction Registers

Bits in the port E and port F data direction registers (DDRE and DDRF) control the direction of the pin drivers when the pins are configured as I/O. Any bit in a register set to one configures the corresponding pin as an output. Any bit in a register cleared to zero configures the corresponding pin as an input. These registers can be read or written at any time. Writes have no effect.

4.9.3 Data Registers

A write to the port E and port F data registers (PORTE and PORTF) is stored in an internal data latch, and if any pin in the corresponding port is configured as an output, the value stored for that bit is driven out on the pin. A read of a data register returns the value at the pin only if the pin is configured as a discrete input. Otherwise, the value read is the value stored in the register. Both data registers can be accessed in two locations. Registers can be read or written at any time.

4.10 Factory Test

The test submodule supports scan-based testing of the various MCU modules. It is integrated into the SIM to support production test. Test submodule registers are intended for Freescale use only. Register names and addresses are provided in **APPENDIX D REGISTER SUMMARY** to show the user that these addresses are occupied. The QUOT pin is also used for factory test.



SECTION 5 CENTRAL PROCESSING UNIT

The CPU32, the instruction processing module of the M68300 family, is based on the industry-standard MC68000 processor. It has many features of the MC68010 and MC68020, as well as unique features suited for high-performance controller applications. This section is an overview of the CPU32. For detailed information concerning CPU operation, refer to the *CPU32 Reference Manual* (CPU32RM/AD).

5.1 General

Ease of programming is an important consideration in using a microcontroller. The CPU32 instruction format reflects a philosophy emphasizing register-memory interaction. There are eight multifunction data registers and seven general-purpose addressing registers.

All data resources are available to all operations requiring those resources. The data registers readily support 8-bit (byte), 16-bit (word), and 32-bit (long-word) operand lengths for all operations. Word and long-word operations support address manipulation. Although the program counter (PC) and stack pointers (SP) are special-purpose registers, they are also available for most data addressing activities. Ease of program checking and diagnosis is further enhanced by trace and trap capabilities at the instruction level.

A block diagram of the CPU32 is shown in **Figure 5-1**. The major blocks operate in a highly independent fashion that maximizes concurrence of operation while managing the essential synchronization of instruction execution and bus operation. The bus controller loads instructions from the data bus into the decode unit. The sequencer and control unit provide overall chip control, managing the internal buses, registers, and functions of the execution unit.

5

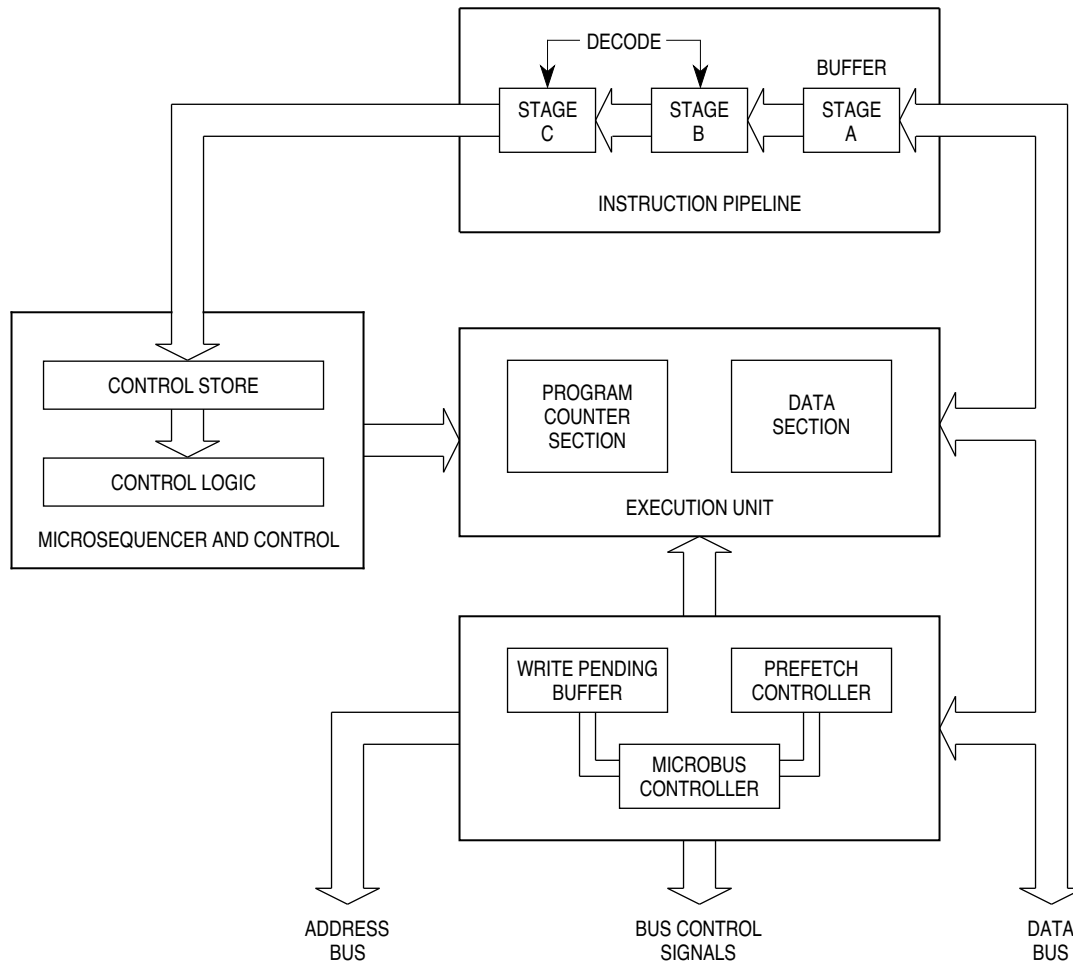

1127A

Figure 5-1 CPU32 Block Diagram

5.2 CPU32 Registers

The CPU32 programming model consists of two groups of registers that correspond to the user and supervisor privilege levels. User programs can use only the registers of the user model. The supervisor programming model, which supplements the user programming model, is used by CPU32 system programmers who wish to protect sensitive operating system functions. The supervisor model is identical to that of the MC68010 and later processors.

The CPU32 has eight 32-bit data registers, seven 32-bit address registers, a 32-bit program counter, separate 32-bit supervisor and user stack pointers, a 16-bit status register, two alternate function code registers, and a 32-bit vector base register (see **Figure 5-2** and **Figure 5-3**).

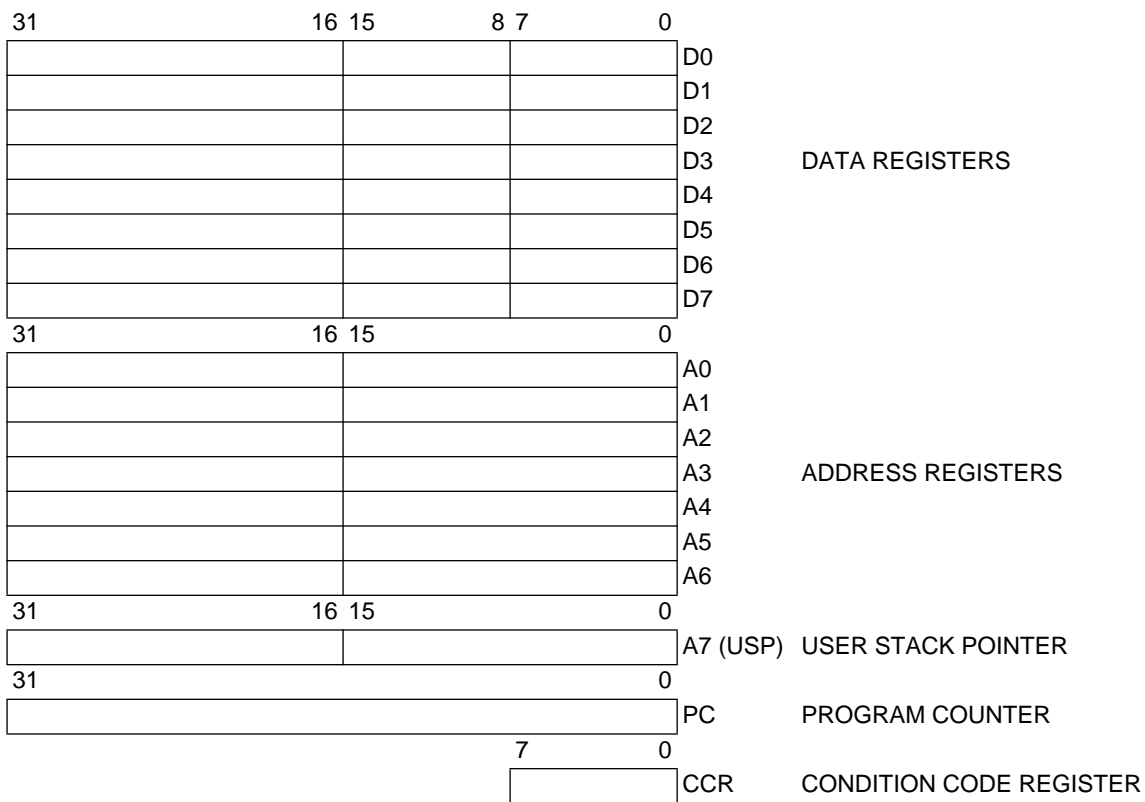

Figure 5-2 User Programming Model

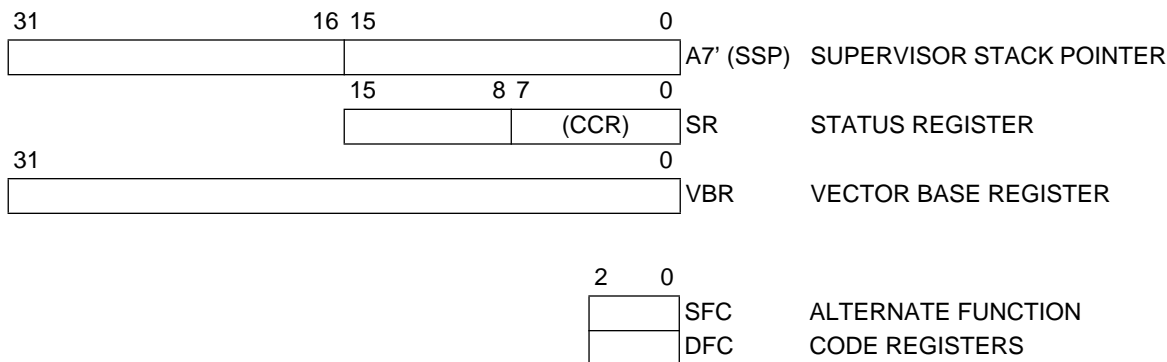

Figure 5-3 Supervisor Programming Model Supplement

5.2.1 Data Registers

The eight data registers can store data operands of 1, 8, 16, 32, and 64 bits and addresses of 16 or 32 bits. The following data types are supported:

- Bits
- Packed Binary-Coded Decimal Digits
- Byte Integers (8 bits)
- Word Integers (16 bits)
- Long-Word Integers (32 bits)
- Quad-Word Integers (64 bits)

Each of data registers D7–D0 is 32 bits wide. Byte operands occupy the low-order 8 bits; word operands, the low-order 16 bits; and long-word operands, the entire 32 bits. When a data register is used as either a source or destination operand, only the appropriate low-order byte or word (in byte or word operations, respectively) is used or changed; the remaining high-order portion is unaffected. The least significant bit (LSB) of a long-word integer is addressed as bit zero, and the most significant bit (MSB) is addressed as bit 31. **Figure 5-4** shows the organization of various types of data in the data registers.

Quad-word data consists of two long words and represents the product of 32-bit multiply or the dividend of 32-bit divide operations (signed and unsigned). Quad-words may be organized in any two data registers without restrictions on order or pairing. There are no explicit instructions for the management of this data type, although the MOVEM instruction can be used to move a quad-word into or out of the registers.

Binary-coded decimal (BCD) data represents decimal numbers in binary form. CPU32 BCD instructions use a format in which a byte contains two digits. The four LSB contain the least significant digit, and the four MSB contain the most significant digit. The ABCD, SBCD, and NBCD instructions operate on two BCD digits packed into a single byte.

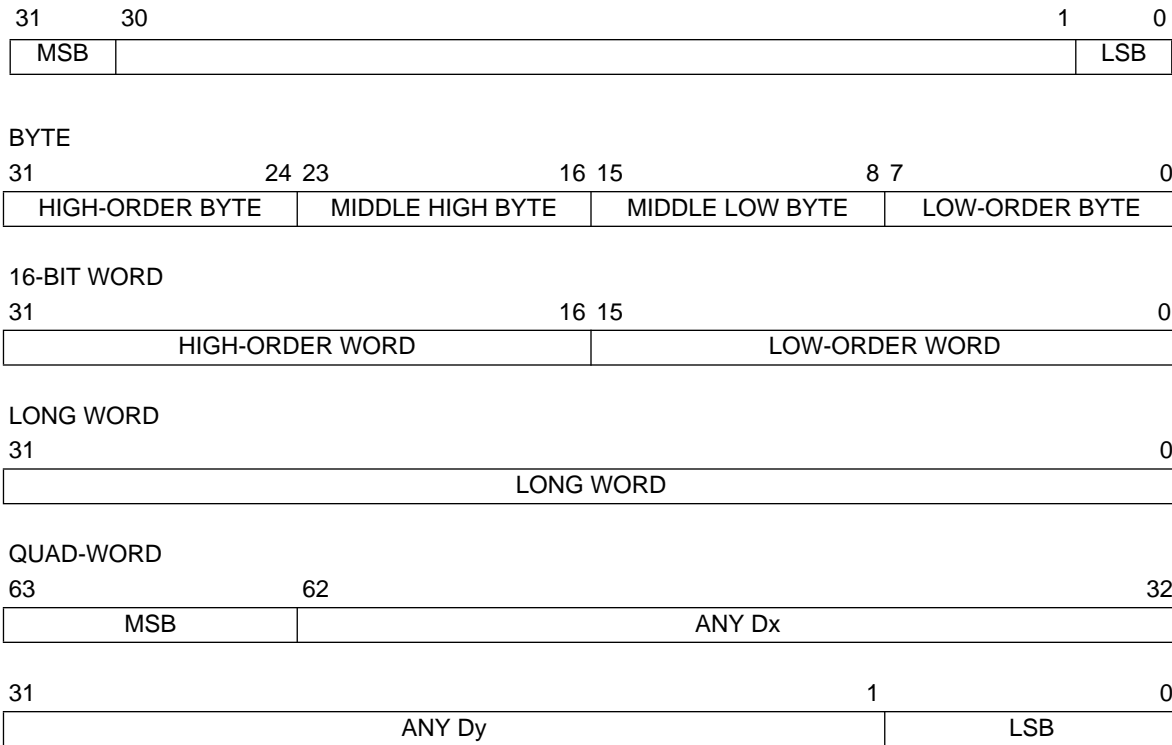

Figure 5-4 Data Organization in Data Registers

5.2.2 Address Registers

Each address register and stack pointer is 32 bits wide and holds a 32-bit address. Address registers cannot be used for byte-sized operands. Therefore, when an address register is used as a source operand, either the low-order word or the entire long-word operand is used, depending upon the operation size. When an address register is used as the destination operand, the entire register is affected, regardless of the operation size. If the source operand is a word size, it is sign-extended to 32 bits. Address registers are used primarily for addresses and to support address computation. The instruction set includes instructions that add to, subtract from, compare, and move the contents of address registers. **Figure 5-5** shows the organization of addresses in address registers.

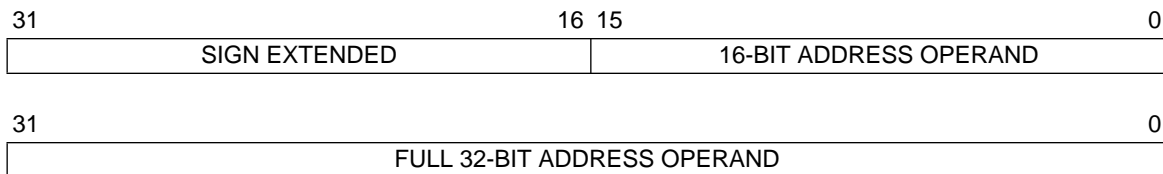

Figure 5-5 Address Organization in Address Registers

5.2.3 Program Counter

The PC contains the address of the next instruction to be executed by the CPU32. During instruction execution and exception processing, the processor automatically increments the contents of the PC or places a new value in the PC as appropriate.

5.2.4 Control Registers

The control registers described in this section contain control information for supervisor functions and vary in size. With the exception of the condition code register (the user portion of the status register), they are accessed only by instructions at the supervisor privilege level.

5.2.4.1 Status Register

The status register (SR) stores the processor status. It contains the condition codes that reflect the results of a previous operation and can be used for conditional instruction execution in a program. The condition codes are extend (X), negative (N), zero (Z), overflow (V), and carry (C). The user (low-order) byte containing the condition codes is the only portion of the SR information available at the user privilege level; it is referenced as the condition code register (CCR) in user programs.

At the supervisor privilege level, software can access the full status register. The upper byte of this register includes the interrupt priority (IP) mask (three bits), two bits for placing the processor in one of two tracing modes or disabling tracing, and the supervisor/user bit for placing the processor at the desired privilege level.

Undefined bits in the status register are reserved by Freescale for future definition. The undefined bits are read as zeros and should be written as zeros for future compatibility.

All operations to the SR and CCR are word-size operations, but for all CCR operations, the upper byte is read as all zeros and is ignored when written, regardless of privilege level.

Refer to **APPENDIX D REGISTER SUMMARY** for bit/field definitions and a diagram of the status register.

5.2.4.2 Alternate Function Code Registers

Alternate function code registers (SFC and DFC) contain 3-bit function codes. Function codes can be considered extensions of the 24-bit linear address that optionally provide as many as eight 16-Mbyte address spaces. The processor automatically generates function codes to select address spaces for data and programs at the user and supervisor privilege levels and to select a CPU address space used for processor functions (such as breakpoint and interrupt acknowledge cycles).

Registers SFC and DFC are used by the MOVES instruction to specify explicitly the function codes of the memory address. The MOVEC instruction is used to transfer values to and from the alternate function code registers. This is a long-word transfer; the upper 29 bits are read as zeros and are ignored when written.

5.2.5 Vector Base Register (VBR)

The VBR contains the base address of the 1024-byte exception vector table, consisting of 256 exception vectors. Exception vectors contain the memory addresses of routines that begin execution at the completion of exception processing. Refer to **5.9 Exception Processing** for more information on the VBR and exception processing.

5.3 Memory Organization

Memory is organized on a byte-addressable basis in which lower addresses correspond to higher order bytes. For example, the address N of a long-word data item corresponds to the address of the most significant byte of the highest order word. The address of the most significant byte of the low-order word is $N + 2$, and the address of the least significant byte of the long word is $N + 3$. The CPU32 requires long-word and word data and instructions to be aligned on word boundaries (refer to **Figure 5-6**). Data misalignment is not supported.

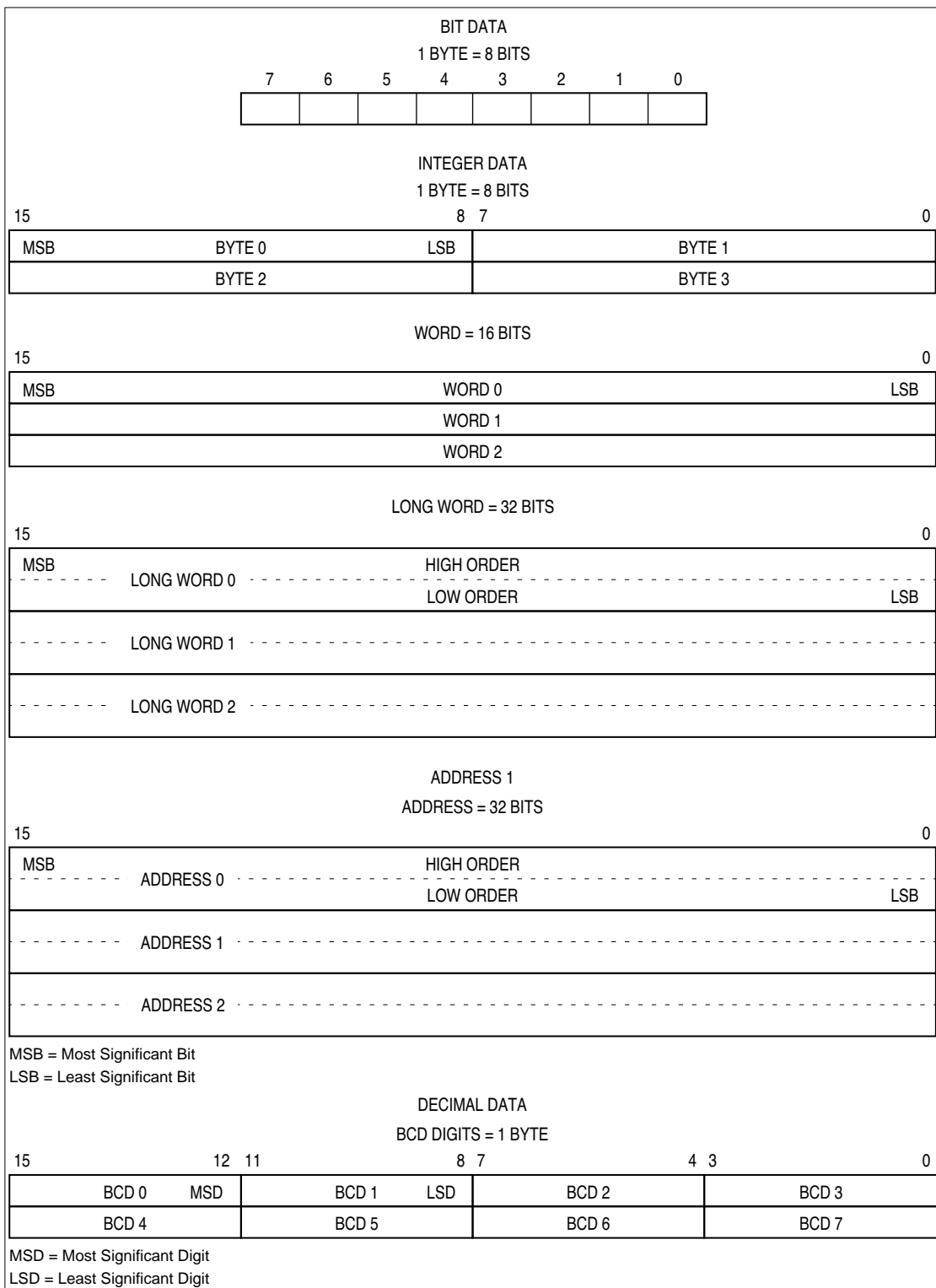

1125A

Figure 5-6 Memory Operand Addressing

5.4 Virtual Memory

The full addressing range of the CPU32 on the MC68331 is 16 Mbytes in each of eight address spaces. Even though most systems implement a smaller physical memory, the system can be made to appear to have a full 16 Mbytes of memory available to each user program by using virtual memory techniques.

A system that supports virtual memory has a limited amount of high-speed physical memory that can be accessed directly by the processor and maintains an image of a much larger virtual memory on a secondary storage device. When the processor attempts to access a location in the virtual memory map that is not resident in physical memory, a page fault occurs. The access to that location is temporarily suspended while the necessary data is fetched from secondary storage and placed in physical memory. The suspended access is then restarted or continued.

The CPU32 uses instruction restart, which requires that only a small portion of the internal machine state be saved. After correcting the fault, the machine state is restored, and the instruction is fetched and started again. This process is completely transparent to the application program.

5.5 Addressing Modes

Addressing in the CPU32 is register-oriented. Most instructions allow the results of the specified operation to be placed either in a register or directly in memory. There is no need for extra instructions to store register contents in memory.

There are seven basic addressing modes:

- Register Direct
- Register Indirect
- Register Indirect with Index
- Program Counter Indirect with Displacement
- Program Counter Indirect with Index
- Absolute
- Immediate

The register indirect addressing modes include postincrement, predecrement, and offset capability. The program counter indirect mode also has index and offset capabilities. In addition to these addressing modes, many instructions implicitly specify the use of the status register, stack pointer, and/or program counter.

5.6 Processing States

The processor is always in one of four processing states: normal, exception, halted, or background. The normal processing state is associated with instruction execution; the bus is used to fetch instructions and operands and to store results.

The exception processing state is associated with interrupts, trap instructions, tracing, and other exception conditions. The exception may be internally generated explicitly by an instruction or by an unusual condition arising during the execution of an instruction. Exception processing can be forced externally by an interrupt, a bus error, or a reset.

The halted processing state is an indication of catastrophic hardware failure. For example, if during the exception processing of a bus error another bus error occurs, the processor assumes that the system is unusable and halts.

The background processing state is initiated by breakpoints, execution of special instructions, or a double bus fault. Background processing is enabled by pulling $\overline{\text{BKPT}}$ low during $\overline{\text{RESET}}$. Background processing allows interactive debugging of the system via a simple serial interface.

5.7 Privilege Levels

The processor operates at one of two levels of privilege: user or supervisor. Not all instructions are permitted to execute at the user level, but all instructions are available at the supervisor level. Effective use of privilege level can protect system resources from uncontrolled access. The state of the S bit in the status register determines the privilege level and whether the user stack pointer (USP) or supervisor stack pointer (SSP) is used for stack operations.

5.8 Instructions

The CPU32 instruction set is summarized in **Table 5-1**. The instruction set of the CPU32 is very similar to that of the MC68020. Two new instructions have been added to facilitate controller applications: low-power stop (LPSTOP) and table lookup and interpolate (TBLS, TBLSN, TBLU, TBLUN).

The following MC68020 instructions are not implemented on the CPU32:

- BFxxx — Bit Field Instructions (BFCHG, BFCLR, BFEXTS, BFEXTU, BFFFO, BFINS, BFSET, BFTST)
- CALLM, RTM — Call Module, Return Module
- CAS, CAS2 — Compare and Swap (Read-Modify-Write Instructions)
- cpxxx — Coprocessor Instructions (cpBcc, cpDBcc, cpGEN, cpRESTORE, cpSAVE, cpScc, cpTRAPcc)
- PACK, UNPK — Pack, Unpack BCD Instructions
- Memory — Memory Indirect Addressing Modes

The CPU32 traps on unimplemented instructions or illegal effective addressing modes, allowing user-supplied code to emulate unimplemented capabilities or to define special purpose functions. However, Freescale reserves the right to use all currently unimplemented instruction operation codes for future M68000 core enhancements.

Table 5-1 Instruction Set Summary

Instruction	Syntax	Operand Size	Operation
ABCD	Dn, Dn–(An), –(An)	8 8	Source ₁₀ + Destination ₁₀ + X ⇒ Destination
ADD	Dn, <ea> <ea>, Dn	8, 16, 32 8, 16, 32	Source + Destination ⇒ Destination
ADDA	<ea>, An	16, 32	Source + Destination ⇒ Destination
ADDI	#<data>, <ea>	8, 16, 32	Immediate data + Destination ⇒ Destination
ADDQ	#<data>, <ea>	8, 16, 32	Immediate data + Destination ⇒ Destination
ADDX	Dn, Dn–(An), –(An)	8, 16, 32 8, 16, 32	Source + Destination + X ⇒ Destination
AND	<ea>, Dn Dn, <ea>	8, 16, 32 8, 16, 32	Source · Destination ⇒ Destination
ANDI	#<data>, <ea>	8, 16, 32	Data · Destination ⇒ Destination
ANDI to CCR	#<data>, CCR	8	Source · CCR ⇒ CCR
ANDI to SR ¹	#<data>, SR	16	Source · SR ⇒ SR
ASL	Dn, Dn #<data>, Dn <ea>	8, 16, 32 8, 16, 32 16	
ASR	Dn, Dn #<data>, Dn <ea>	8, 16, 32 8, 16, 32 16	
Bcc	<label>	8, 16, 32	If condition true, then PC + d ⇒ PC
BCHG	Dn, <ea> #<data>, <ea>	8, 32 8, 32	(<bit number> of destination ⇒ Z ⇒ bit of destination)
BCLR	Dn, <ea> #<data>, <ea>	8, 32 8, 32	(<bit number> of destination ⇒ Z; 0 ⇒ bit of destination)
BGND	none	none	If background mode enabled, then enter background mode, else format/vector offset ⇒ –(SSP); PC ⇒ –(SSP); SR ⇒ –(SSP); (vector) ⇒ PC
BKPT	#<data>	none	If breakpoint cycle acknowledged, then execute returned operation word, else trap as illegal instruction.
BRA	<label>	8, 16, 32	PC + d ⇒ PC
BSET	Dn, <ea> #<data>, <ea>	8, 32 8, 32	(<bit number> of destination ⇒ Z; 1 ⇒ bit of destination)
BSR	<label>	8, 16, 32	SP – 4 ⇒ SP; PC ⇒ (SP); PC + d ⇒ PC
BTST	Dn, <ea> #<data>, <ea>	8, 32 8, 32	(<bit number> of destination ⇒ Z)
CHK	<ea>, Dn	16, 32	If Dn < 0 or Dn < (ea), then CHK exception
CHK2	<ea>, Rn	8, 16, 32	If Rn < lower bound or Rn > upper bound, then CHK exception
CLR	<ea>	8, 16, 32	0 ⇒ Destination
CMP	<ea>, Dn	8, 16, 32	(Destination – Source), CCR shows results
CMPA	<ea>, An	16, 32	(Destination – Source), CCR shows results
CMPI	#<data>, <ea>	8, 16, 32	(Destination – Data), CCR shows results
CMPM	(An) +, (An) +	8, 16, 32	(Destination – Source), CCR shows results
CMP2	<ea>, Rn	8, 16, 32	Lower bound Rn Upper bound, CCR shows result
DBcc	Dn, <label>	16	If condition false, then Dn – 1 ⇒ PC; if Dn ≠ (– 1), then PC + d ⇒ PC
DIVS/DIVU	<ea>, Dn	32/16 ⇒ 16: 16	Destination / Source ⇒ Destination (signed or unsigned)

Table 5-1 Instruction Set Summary (Continued)

Instruction	Syntax	Operand Size	Operation
DIVSL/DIVUL	$\langle ea \rangle, Dr : Dq$ $\langle ea \rangle, Dq$ $\langle ea \rangle, Dr : Dq$	$64/32 \Rightarrow 32 : 32$ $32/32 \Rightarrow 32$ $32/32 \Rightarrow 32 : 32$	Destination / Source \Rightarrow Destination (signed or unsigned)
EOR	$Dn, \langle ea \rangle$	8, 16, 32	Source \oplus Destination \Rightarrow Destination
EORI	$\#(data), \langle ea \rangle$	8, 16, 32	Data \oplus Destination \Rightarrow Destination
EORI to CCR	$\#(data), CCR$	8	Source \oplus CCR \Rightarrow CCR
EORI to SR ¹	$\#(data), SR$	16	Source \oplus SR \Rightarrow SR
EXG	Rn, Rn	32	$Rn \Rightarrow Rn$
EXT	Dn Dn	$8 \Rightarrow 16$ $16 \Rightarrow 32$	Sign extended Destination \Rightarrow Destination
EXTB	Dn	$8 \Rightarrow 32$	Sign extended Destination \Rightarrow Destination
ILLEGAL	none	none	SSP - 2 \Rightarrow SSP; vector offset \Rightarrow (SSP); SSP - 4 \Rightarrow SSP; PC \Rightarrow (SSP); SSP - 2 \Rightarrow SSP; SR \Rightarrow (SSP); illegal instruction vector address \Rightarrow PC
JMP	$\langle ea \rangle$	none	Destination \Rightarrow PC
JSR	$\langle ea \rangle$	none	SP - 4 \Rightarrow SP; PC \Rightarrow (SP); destination \Rightarrow PC
LEA	$\langle ea \rangle, An$	32	$\langle ea \rangle \Rightarrow An$
LINK	$An, \#(d)$	16, 32	SP - 4 \Rightarrow SP, An \Rightarrow (SP); SP \Rightarrow An, SP + d \Rightarrow SP
LPSTOP ¹	$\#(data)$	none	Data \Rightarrow SR; interrupt mask \Rightarrow EBI; STOP
LSL	Dn, Dn $\#(data), Dn$ $\langle ea \rangle$	8, 16, 32 8, 16, 32 16	
LSR	Dn, Dn $\#(data), Dn$ $\langle ea \rangle$	8, 16, 32 8, 16, 32 16	
MOVE	$\langle ea \rangle, \langle ea \rangle$	8, 16, 32	Source \Rightarrow Destination
MOVEA	$\langle ea \rangle, An$	16, 32 \Rightarrow 32	Source \Rightarrow Destination
MOVEA ¹	USP, An An, USP	32 32	USP \Rightarrow An An \Rightarrow USP
MOVE from CCR	CCR, $\langle ea \rangle$	16	CCR \Rightarrow Destination
MOVE to CCR	$\langle ea \rangle, CCR$	16	Source \Rightarrow CCR
MOVE from SR ¹	SR, $\langle ea \rangle$	16	SR \Rightarrow Destination
MOVE to SR ¹	$\langle ea \rangle, SR$	16	Source \Rightarrow SR
MOVE USP ¹	USP, An An, USP	32 32	USP \Rightarrow An An \Rightarrow USP
MOVEC ¹	Rc, Rn Rn, Rc	32 32	$Rc \Rightarrow Rn$ $Rn \Rightarrow Rc$
MOVEM	list, $\langle ea \rangle$ $\langle ea \rangle, list$	16, 32 16, 32 \Rightarrow 32	Listed registers \Rightarrow Destination Source \Rightarrow Listed registers
MOVEP	$Dn, (d_{16}, An)$ $(d_{16}, An), Dn$	16, 32	$Dn [31 : 24] \Rightarrow (An + d)$; $Dn [23 : 16] \Rightarrow (An + d + 2)$; $Dn [15 : 8] \Rightarrow (An + d + 4)$; $Dn [7 : 0] \Rightarrow (An + d + 6)$ $(An + d) \Rightarrow Dn [31 : 24]$; $(An + d + 2) \Rightarrow Dn [23 : 16]$; $(An + d + 4) \Rightarrow Dn [15 : 8]$; $(An + d + 6) \Rightarrow Dn [7 : 0]$
MOVEQ	$\#(data), Dn$	$8 \Rightarrow 32$	Immediate data \Rightarrow Destination
MOVES ¹	$Rn, \langle ea \rangle$ $\langle ea \rangle, Rn$	8, 16, 32	$Rn \Rightarrow$ Destination using DFC Source using SFC $\Rightarrow Rn$
MULS/MULU	$\langle ea \rangle, Dn$ $\langle ea \rangle, Dl$ $\langle ea \rangle, Dh : Dl$	$16 * 16 \Rightarrow 32$ $32 * 32 \Rightarrow 32$ $32 * 32 \Rightarrow 64$	Source * Destination \Rightarrow Destination (signed or unsigned)
NBCD	$\langle ea \rangle$	8 8	$0 - Destination_{10} - X \Rightarrow$ Destination

Table 5-1 Instruction Set Summary (Continued)

Instruction	Syntax	Operand Size	Operation
NEG	<ea>	8, 16, 32	0 – Destination \Rightarrow Destination
NEGX	<ea>	8, 16, 32	0 – Destination – X \Rightarrow Destination
NOP	none	none	PC + 2 \Rightarrow PC
NOT	<ea>	8, 16, 32	$\overline{\text{Destination}} \Rightarrow \text{Destination}$
OR	<ea>, Dn Dn, <ea>	8, 16, 32 8, 16, 32	Source; Destination \Rightarrow Destination
ORI	#<data>, <ea>	8, 16, 32	Data; Destination \Rightarrow Destination
ORI to CCR	#<data>, CCR	16	Source; CCR \Rightarrow SR
ORI to SR ¹	#<data>, SR	16	Source; SR \Rightarrow SR
PEA	<ea>	32	SP – 4 \Rightarrow SP; <ea> \Rightarrow SP
RESET ¹	none	none	Assert RESET line
ROL	Dn, Dn #<data>, Dn <ea>	8, 16, 32 8, 16, 32 16	
ROR	Dn, Dn #<data>, Dn <ea>	8, 16, 32 8, 16, 32 16	
ROXL	Dn, Dn #<data>, Dn<ea>	8, 16, 32 8, 16, 32 16	
ROXR	Dn, Dn #<data>, Dn <ea>	8, 16, 32 8, 16, 32 16	
RTD	#<d>	16	(SP) \Rightarrow PC; SP + 4 + d \Rightarrow SP
RTE ¹	none	none	(SP) \Rightarrow SR; SP + 2 \Rightarrow SP; (SP) \Rightarrow PC; SP + 4 \Rightarrow SP; restore stack according to format
RTR	none	none	(SP) \Rightarrow CCR; SP + 2 \Rightarrow SP; (SP) \Rightarrow PC; SP + 4 \Rightarrow SP
RTS	none	none	(SP) \Rightarrow PC; SP + 4 \Rightarrow SP
SBCD	Dn, Dn – (An), – (An)	88	Destination ₁₀ – Source ₁₀ – X \Rightarrow Destination
Scc	<ea>	8	If condition true, then destination bits are set to 1; else, destination bits are cleared to 0
STOP ¹	#<data>	16	Data \Rightarrow SR; STOP
SUB	<ea>, Dn Dn, <ea>	8, 16, 32	Destination – Source \Rightarrow Destination
SUBA	<ea>, An	16, 32	Destination – Source \Rightarrow Destination
SUBI	#<data>, <ea>	8, 16, 32	Destination – Data \Rightarrow Destination
SUBQ	#<data>, <ea>	8, 16, 32	Destination – Data \Rightarrow Destination
SUBX	Dn, Dn – (An), – (An)	8, 16, 32 8, 16, 32	Destination – Source – X \Rightarrow Destination
SWAP	Dn	16	
TBLS/TBLU	<ea>, Dn Dym : Dyn, Dn	8, 16, 32	Dyn – Dym \Rightarrow Temp (Temp * Dn [7 : 0]) \Rightarrow Temp (Dym * 256) + Temp \Rightarrow Dn
TBLSN/TBLUN	<ea>, Dn Dym : Dyn, Dn	8, 16, 32	Dyn – Dym \Rightarrow Temp (Temp * Dn [7 : 0]) / 256 \Rightarrow Temp Dym + Temp \Rightarrow Dn
TRAP	#<data>	none	SSP – 2 \Rightarrow SSP; format/vector offset \Rightarrow (SSP); SSP – 4 \Rightarrow SSP; PC \Rightarrow (SSP); SR \Rightarrow (SSP); vector address \Rightarrow PC

Table 5-1 Instruction Set Summary (Continued)

Instruction	Syntax	Operand Size	Operation
TRAPcc	none #<data>	none 16, 32	If cc true, then TRAP exception
TRAPV	none	none	If V set, then overflow TRAP exception
TST	<ea>	8, 16, 32	Source – 0, to set condition codes
UNLK	An	32	An ⇒ SP; (SP) ⇒ An, SP + 4 ⇒ SP

NOTE:

1. Privileged instruction

5.8.1 M68000 Family Compatibility

It is the philosophy of the M68000 family that all user-mode programs can execute unchanged on a more advanced processor, and supervisor-mode programs and exception handlers should require only minimal alteration.

The CPU32 can be thought of as an intermediate member of the M68000 Family. Object code from an MC68000 or MC68010 may be executed on the CPU32, and many of the instruction and addressing mode extensions of the MC68020 are also supported. Refer to the CPU32 reference manual for a detailed comparison of the CPU32 and MC68020 instruction set.

5.8.2 Special Control Instructions

Low power stop (LPSTOP) and table lookup and interpolate (TBL) instructions have been added to the MC68000 instruction set for use in controller applications.

5.8.2.1 Low Power Stop (LPSTOP)

In applications where power consumption is a consideration, the CPU32 forces the device into a low power standby mode when immediate processing is not required. The low power stop mode is entered by executing the LPSTOP instruction. The processor remains in this mode until a user-specified (or higher) interrupt level or reset occurs.

5.8.2.2 Table Lookup and Interpolate (TBL)

To maximize throughput for real-time applications, reference data is often precalculated and stored in memory for quick access. Storage of many data points can require an inordinate amount of memory. The table instruction requires that only a sample of data points be stored, reducing memory requirements. The TBL instruction recovers intermediate values using linear interpolation. Results can be rounded with a round-to-nearest algorithm.

5.9 Exception Processing

Exception processing is a special condition that preempts normal processing. Exception processing is the transition from normal mode program execution to execution of a routine that deals with an exception.

5.9.1 Exception Vectors

An exception vector is the address of a routine that handles an exception. The vector base register (VBR) contains the base address of a 1024-byte exception vector table, which consists of 256 exception vectors. Sixty-four vectors are defined by the processor, and 192 vectors are reserved for user definition as interrupt vectors. Except for the reset vector, each vector in the table is one long word in length. The reset vector is two long words in length. Refer to **Table 5-2** for information on vector assignment.

CAUTION

Because there is no protection on the 64 processor-defined vectors, external devices can access vectors reserved for internal purposes. This practice is strongly discouraged.

All exception vectors, except the reset vector, are located in supervisor data space. The reset vector is located in supervisor program space. Only the initial reset vector is fixed in the processor memory map. When initialization is complete, there are no fixed assignments. Since the VBR stores the vector table base address, the table can be located anywhere in memory. It can also be dynamically relocated for each task executed by an operating system.

Table 5-2 Exception Vector Assignments

Vector Number	Vector Offset			Assignment
	Dec	Hex	Space	
0	0	000	SP	Reset: Initial Stack Pointer
1	4	004	SP	Reset: Initial Program Counter
2	8	008	SD	Bus Error
3	12	00C	SD	Address Error
4	16	010	SD	Illegal Instruction
5	20	014	SD	Zero Division
6	24	018	SD	CHK, CHK2 Instructions
7	28	01C	SD	TRAPcc, TRAPV Instructions
8	32	020	SD	Privilege Violation
9	36	024	SD	Trace
10	40	028	SD	Line 1010 Emulator
11	44	02C	SD	Line 1111 Emulator
12	48	030	SD	Hardware Breakpoint
13	52	034	SD	(Reserved, Coprocessor Protocol Violation)
14	56	038	SD	Format Error and Uninitialized Interrupt
15	60	03C	SD	Format Error and Uninitialized Interrupt
16–23	64 92	040 05C	SD	(Unassigned, Reserved)
24	96	060	SD	Spurious Interrupt
25	100	064	SD	Level 1 Interrupt Autovector
26	104	068	SD	Level 2 Interrupt Autovector
27	108	06C	SD	Level 3 Interrupt Autovector
28	112	070	SD	Level 4 Interrupt Autovector
29	116	074	SD	Level 5 Interrupt Autovector
30	120	078	SD	Level 6 Interrupt Autovector
31	124	07C	SD	Level 7 Interrupt Autovector
32–47	128 188	080 0BC	SD	Trap Instruction Vectors (0–15)
48–58	192 232	0C0 0E8	SD	(Reserved, Coprocessor)
59–63	236 252	0EC 0FC	SD	(Unassigned, Reserved)
64–255	256 1020	100 3FC	SD	User Defined Vectors (192)

Each vector is assigned an 8-bit number. Vector numbers for some exceptions are obtained from an external device; others are supplied by the processor. The processor multiplies the vector number by four to calculate vector offset, then adds the offset to the contents of the VBR. The sum is the memory address of the vector.

5.9.2 Types of Exceptions

An exception can be caused by internal or external events.

An internal exception can be generated by an instruction or by an error. The TRAP, TRAPcc, TRAPV, BKPT, CHK, CHK2, RTE, and DIV instructions can cause exceptions during normal execution. Illegal instructions, instruction fetches from odd addresses, word or long-word operand accesses from odd addresses, and privilege violations also cause internal exceptions.

Sources of external exception include interrupts, breakpoints, bus errors, and reset requests. Interrupts are peripheral device requests for processor action. Breakpoints are used to support development equipment. Bus error and reset are used for access control and processor restart.

5.9.3 Exception Processing Sequence

For all exceptions other than a reset exception, exception processing occurs in the following sequence. Refer to **4.6 Reset** for details of reset processing.

As exception processing begins, the processor makes an internal copy of the status register. After the copy is made, the processor state bits in the status register are changed — the S bit is set, establishing supervisor access level, and bits T1 and T0 are cleared, disabling tracing. For reset and interrupt exceptions, the interrupt priority mask is also updated.

Next, the exception number is obtained. For interrupts, the number is fetched from CPU space \$F (the bus cycle is an interrupt acknowledge). For all other exceptions, internal logic provides a vector number.

Next, current processor status is saved. An exception stack frame is created and placed on the supervisor stack. All stack frames contain copies of the status register and the program counter for use by RTE. The type of exception and the context in which the exception occurs determine what other information is stored in the stack frame.

Finally, the processor prepares to resume normal execution of instructions. The exception vector offset is determined by multiplying the vector number by four, and the offset is added to the contents of the VBR to determine displacement into the exception vector table. The exception vector is loaded into the program counter. If no other exception is pending, the processor will resume normal execution at the new address in the PC.

5.10 Development Support

The following features have been implemented on the CPU32 to enhance the instrumentation and development environment:

- M68000 Family Development Support
- Background Debugging Mode
- Deterministic Opcode Tracking
- Hardware Breakpoints

5.10.1 M68000 Family Development Support

All M68000 Family members include features to facilitate applications development. These features include the following:

Trace on Instruction Execution — M68000 Family processors include an instruction-by-instruction tracing facility as an aid to program development. The MC68020, MC68030, MC68040, and CPU32 also allow tracing only of those instructions

causing a change in program flow. In the trace mode, a trace exception is generated after an instruction is executed, allowing a debugger program to monitor the execution of a program under test.

Breakpoint Instruction — An emulator may insert software breakpoints into the target code to indicate when a breakpoint has occurred. On the MC68010, MC68020, MC68030, and CPU32, this function is provided via illegal instructions, \$4848–\$484F, to serve as breakpoint instructions.

Unimplemented Instruction Emulation — During instruction execution, when an attempt is made to execute an illegal instruction, an illegal instruction exception occurs. Unimplemented instructions (F-line, A-line,...) utilize separate exception vectors to permit efficient emulation of unimplemented instructions in software.

5.10.2 Background Debugging Mode

Microcomputer systems generally provide a debugger, implemented in software, for system analysis at the lowest level. The background debugging mode (BDM) on the CPU32 is unique in that the debugger has been implemented in CPU microcode.

BDM incorporates a full set of debugging options: registers can be viewed or altered, memory can be read or written to, and test features can be invoked.

A resident debugger simplifies implementation of an in-circuit emulator. In a common setup (see **Figure 5-7**), emulator hardware replaces the target system processor. A complex, expensive pod-and-cable interface provides a communication path between the target system and the emulator.

By contrast, an integrated debugger supports use of a bus state analyzer (BSA) for in-circuit emulation. The processor remains in the target system (see **Figure 5-8**) and the interface is simplified. The BSA monitors target processor operation and the on-chip debugger controls the operating environment. Emulation is much “closer” to target hardware, and many interfacing problems (e.g., limitations on high-frequency operation, AC and DC parametric mismatches, and restrictions on cable length) are minimized.

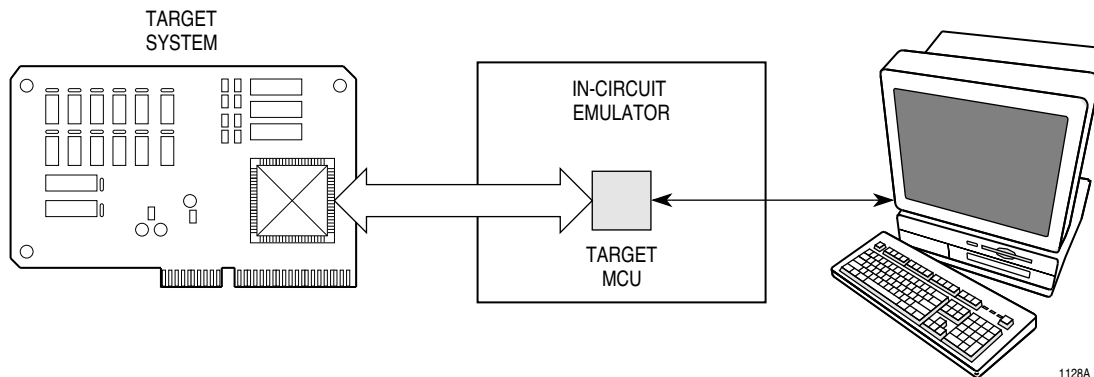

Figure 5-7 Common In-Circuit Emulator Diagram

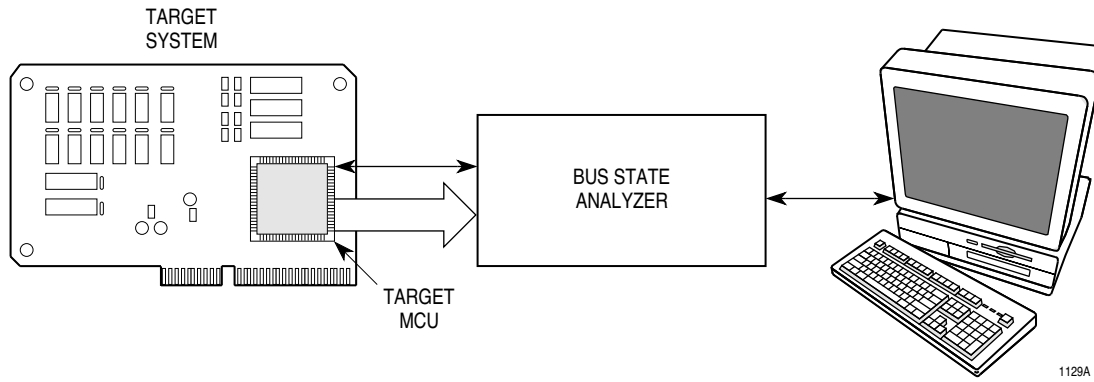

Figure 5-8 Bus State Analyzer Configuration

5.10.2.1 Enabling BDM

Accidentally entering BDM in a non-development environment can lock up the CPU32 when the serial command interface is not available. For this reason, BDM is enabled during reset via the breakpoint ($\overline{\text{BKPT}}$) signal.

BDM operation is enabled when $\overline{\text{BKPT}}$ is asserted (low), at the rising edge of $\overline{\text{RESET}}$. BDM remains enabled until the next system reset. A high $\overline{\text{BKPT}}$ signal on the trailing edge of $\overline{\text{RESET}}$ disables BDM. $\overline{\text{BKPT}}$ is latched again on each rising transition of $\overline{\text{RESET}}$. $\overline{\text{BKPT}}$ is synchronized internally, and must be held low for at least two clock cycles prior to negation of $\overline{\text{RESET}}$.

BDM enable logic must be designed with special care. If hold time on $\overline{\text{BKPT}}$ extends into the first bus cycle following reset, the bus cycle could inadvertently be tagged with a breakpoint. Refer to the *SIM Reference Manual (SIMRM/AD)* for timing information.

5.10.2.2 BDM Sources

When BDM is enabled, any of several sources can cause the transition from normal mode to BDM. These sources include external breakpoint hardware, the BGND instruction, a double bus fault, and internal peripheral breakpoints. If BDM is not enabled when an exception condition occurs, the exception is processed normally. **Table 5-3** summarizes the processing of each source for both enabled and disabled cases. As shown in **Table 5-3**, the BKPT instruction never causes a transition into BDM.

Table 5-3 BDM Source Summary

Source	BDM Enabled	BDM Disabled
$\overline{\text{BKPT}}$	Background	Breakpoint Exception
Double Bus Fault	Background	Halted
BGND Instruction	Background	Illegal Instruction
BKPT Instruction	Opcode Substitution/ Illegal Instruction	Opcode Substitution/ Illegal Instruction

5.10.2.2.1 External $\overline{\text{BKPT}}$ Signal

Once enabled, BDM is initiated whenever assertion of $\overline{\text{BKPT}}$ is acknowledged. If BDM is disabled, a breakpoint exception (vector \$0C) is acknowledged. The $\overline{\text{BKPT}}$ input has the same timing relationship to the data strobe trailing edge as does read cycle data. There is no breakpoint acknowledge bus cycle when BDM is entered.

5.10.2.2.2 BGND Instruction

An illegal instruction, \$4AFA, is reserved for use by development tools. The CPU32 defines \$4AFA (BGND) to be a BDM entry point when BDM is enabled. If BDM is disabled, an illegal instruction trap is acknowledged.

5.10.2.2.3 Double Bus Fault

The CPU32 normally treats a double bus fault, or two bus faults in succession, as a catastrophic system error, and halts. When this condition occurs during initial system debug (a fault in the reset logic), further debugging is impossible until the problem is corrected. In BDM, the fault can be temporarily bypassed, so that the origin of the fault can be isolated and eliminated.

5.10.2.2.4 Peripheral Breakpoints

CPU32 peripheral breakpoints are implemented in the same way as external breakpoints — peripherals request breakpoints by asserting the $\overline{\text{BKPT}}$ signal. Consult the appropriate peripheral user's manual for additional details on the generation of peripheral breakpoints.

5.10.2.3 Entering BDM

When the processor detects a breakpoint or a double bus fault, or decodes a BGND instruction, it suspends instruction execution and asserts the FREEZE output. This is the first indication that the processor has entered BDM. Once FREEZE has been asserted, the CPU enables the serial communication hardware and awaits a command.

The CPU writes a unique value indicating the source of BDM transition into temporary register A (ATEMP) as part of the process of entering BDM. A user can poll ATEMP and determine the source (see **Table 5-4**) by issuing a read system register command (RSREG). ATEMP is used in most debugger commands for temporary storage — it is imperative that the RSREG command be the first command issued after transition into BDM.

Table 5-4 Polling the BDM Entry Source

Source	ATEMP[31:16]	ATEMP[15:0]
Double Bus Fault	SSW*	\$FFFF
BGND Instruction	\$0000	\$0001
Hardware Breakpoint	\$0000	\$0000

*Special status word (SSW) is described in detail in the *CPU32 Reference Manual (CPU32RM/AD)*.

A double bus fault during initial stack pointer/program counter (SP/PC) fetch sequence is distinguished by a value of \$FFFFFFFF in the current instruction PC. At no other time will the processor write an odd value into this register.

5.10.2.4 BDM Commands

Commands consist of one 16-bit operation word and can include one or more 16-bit extension words. Each incoming word is read as it is assembled by the serial interface. The microcode routine corresponding to a command is executed as soon as the command is complete. Result operands are loaded into the output shift register to be shifted out as the next command is read. This process is repeated for each command until the CPU returns to normal operating mode. **Table 5-5** is a summary of background mode commands.

Table 5-5 Background Mode Command Summary

Command	Mnemonic	Description
Read D/A Register	RDREG/RAREG	Read the selected address or data register and return the results via the serial interface.
Write D/A Register	WDREG/WAREG	The data operand is written to the specified address or data register.
Read System Register	RSREG	The specified system control register is read. All registers that can be read in supervisor mode can be read in background mode.
Write System Register	WSREG	The operand data is written into the specified system control register.
Read Memory Location	READ	Read the sized data at the memory location specified by the long-word address. The source function code register (SFC) determines the address space accessed.
Write Memory Location	WRITE	Write the operand data to the memory location specified by the long-word address. The destination function code (DFC) register determines the address space accessed.
Dump Memory Block	DUMP	Used in conjunction with the READ command to dump large blocks of memory. An initial READ is executed to set up the starting address of the block and retrieve the first result. Subsequent operands are retrieved with the DUMP command.
Fill Memory Block	FILL	Used in conjunction with the WRITE command to fill large blocks of memory. An initial WRITE is executed to set up the starting address of the block and supply the first operand. Subsequent operands are written with the FILL command.
Resume Execution	GO	The pipe is flushed and re-filled before resuming instruction execution at the current PC.
Patch User Code	CALL	Current program counter is stacked at the location of the current stack pointer. Instruction execution begins at user patch code.
Reset Peripherals	RST	Asserts $\overline{\text{RESET}}$ for 512 clock cycles. The CPU is not reset by this command. Synonymous with the CPU $\overline{\text{RESET}}$ instruction.
No Operation	NOP	NOP performs no operation and may be used as a null command.

5.10.2.5 Background Mode Registers

BDM processing uses three special purpose registers to keep track of program context during development. A description of each follows.

5.10.2.5.1 Fault Address Register (FAR)

The FAR contains the address of the faulting bus cycle immediately following a bus or address error. This address remains available until overwritten by a subsequent bus cycle. Following a double bus fault, the FAR contains the address of the last bus cycle. The address of the first fault (if there was one) is not visible to the user.

5.10.2.5.2 Return Program Counter (RPC)

The RPC points to the location where fetching will commence after transition from background mode to normal mode. This register should be accessed to change the flow of a program under development. Changing the RPC to an odd value will cause an address error when normal mode prefetching begins.

5.10.2.5.3 Current Instruction Program Counter (PCC)

The PCC holds a pointer to the first word of the last instruction executed prior to transition into background mode. Due to instruction pipelining, the instruction pointed to may not be the instruction which caused the transition. An example is a breakpoint on a released write. The bus cycle may overlap as many as two subsequent instructions before stalling the instruction sequencer. A breakpoint asserted during this cycle will not be acknowledged until the end of the instruction executing at completion of the bus cycle. PCC will contain \$00000001 if BDM is entered via a double bus fault immediately out of reset.

5.10.2.6 Returning from BDM

BDM is terminated when a resume execution (GO) or call user code (CALL) command is received. Both GO and CALL flush the instruction pipeline and refetch instructions from the location pointed to by the RPC.

The return PC and the memory space referred to by the status register SUPV bit reflect any changes made during BDM. FREEZE is negated prior to initiating the first prefetch. Upon negation of FREEZE, the serial subsystem is disabled, and the signals revert to $\overline{\text{IPIPE}}/\overline{\text{IFETCH}}$ functionality.

5.10.2.7 Serial Interface

Communication with the CPU32 during BDM occurs via a dedicated serial interface, which shares pins with other development features. **Figure 5-9** is a block diagram of the interface. The $\overline{\text{BKPT}}$ signal becomes the serial clock (DSCLK); serial input data (DSI) is received on $\overline{\text{IFETCH}}$, and serial output data (DSO) is transmitted on $\overline{\text{IPIPE}}$.

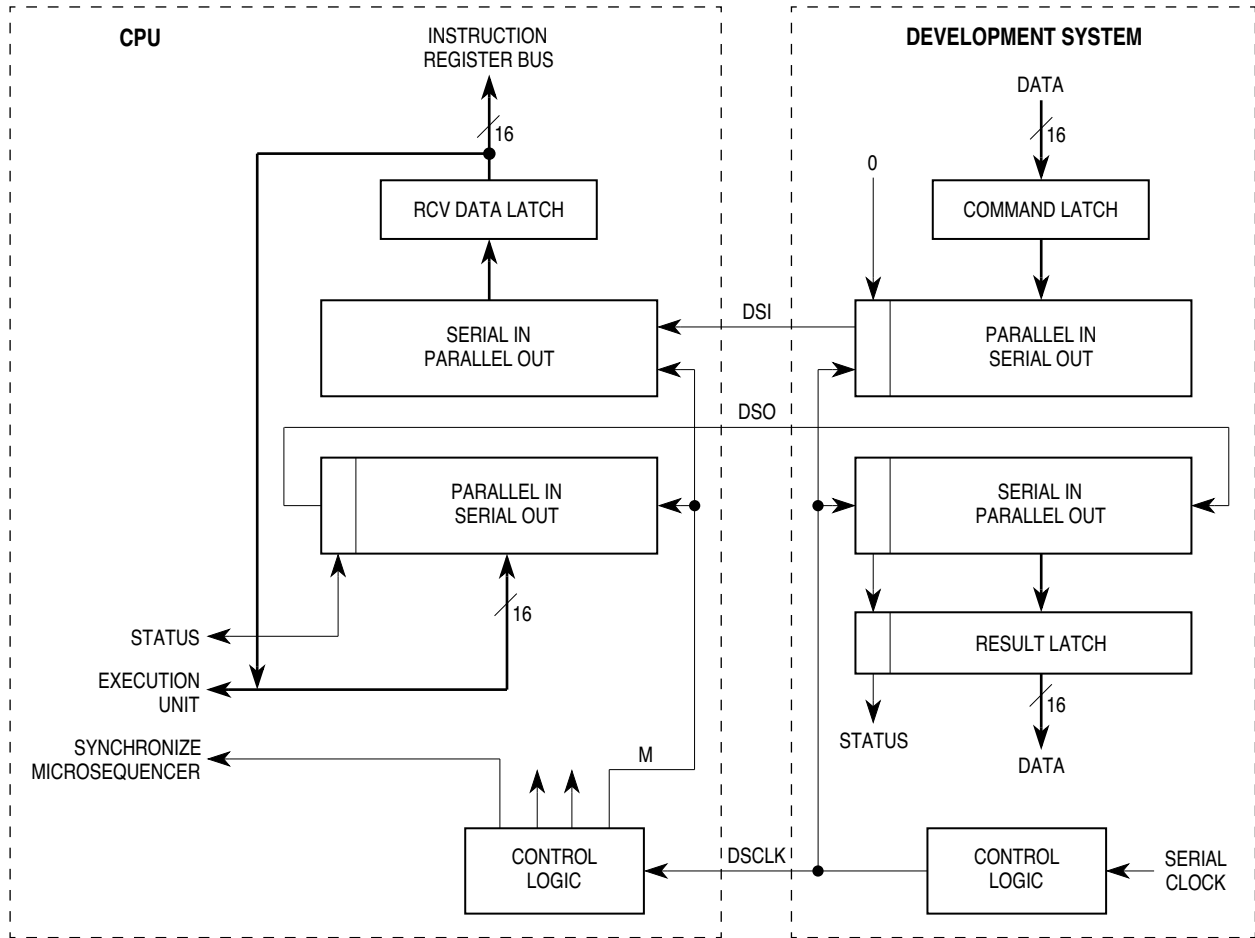

32 DEBUG I/O BLOCK

5

Figure 5-9 Debug Serial I/O Block Diagram

The serial interface uses a full-duplex synchronous protocol similar to the serial peripheral interface (SPI) protocol. The development system serves as the master of the serial link since it is responsible for the generation of DSCLK. If DSCLK is derived from the CPU32 system clock, development system serial logic is unhindered by the operating frequency of the target processor. Operable frequency range of the serial clock is from DC to one-half the processor system clock frequency.

The serial interface operates in full-duplex mode — data is transmitted and received simultaneously by both master and slave devices. In general, data transitions occur on the falling edge of DSCLK and are stable by the following rising edge of DSCLK. Data is transmitted MSB first, and is latched on the rising edge of DSCLK.

The serial data word is 17 bits wide — 16 data bits and a status/control bit. Bit 16 indicates the status of CPU-generated messages as shown in **Table 5-6**.

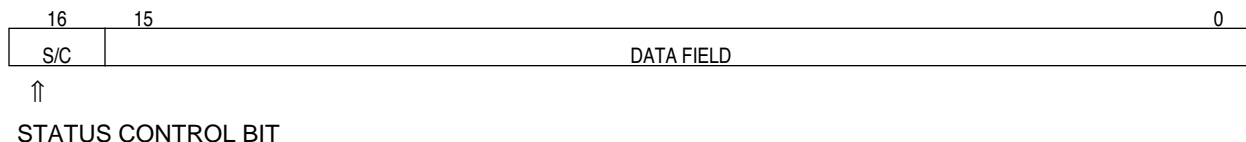

Figure 5-10 BDM Serial Data Word

Table 5-6 CPU Generated Message Encoding

Bit 16	Data	Message Type
0	xxxx	Valid Data Transfer
0	FFFF	Command Complete; Status OK
1	0000	Not Ready with Response; Come Again
1	0001	BERR Terminated Bus Cycle; Data Invalid
1	FFFF	Illegal Command

Command and data transfers initiated by the development system should clear bit 16. The current implementation ignores this bit; however, Freescale reserves the right to use this bit for future enhancements.

5.10.2.8 Recommended BDM Connection

In order to provide for use of development tools when an MCU is installed in a system, Freescale recommends that appropriate signal lines be routed to a male Berg connector or double-row header installed on the circuit board with the MCU, as shown in the following figure.

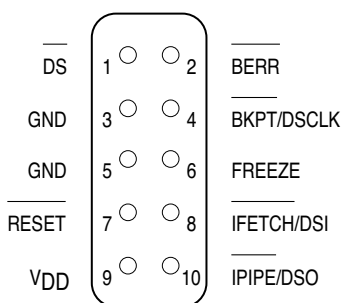

32 BERG

Figure 5-11 BDM Connector Pinout

5.10.3 Deterministic Opcode Tracking

CPU32 function code outputs are augmented by two supplementary signals to monitor the instruction pipeline. The instruction pipe (IPIPE) output indicates the start of each new instruction and each mid-instruction pipeline advance. The instruction fetch

($\overline{\text{IFETCH}}$) output identifies the bus cycles in which the operand is loaded into the instruction pipeline. Pipeline flushes are also signaled with $\overline{\text{IFETCH}}$. Monitoring these two signals allows a bus analyzer to synchronize itself to the instruction stream and monitor its activity.

5.10.4 On-Chip Breakpoint Hardware

An external breakpoint input and on-chip breakpoint hardware allow a breakpoint trap on any memory access. Off-chip address comparators preclude breakpoints unless show cycles are enabled. Breakpoints on instruction prefetches that are ultimately flushed from the instruction pipeline are not acknowledged; operand breakpoints are always acknowledged. Acknowledged breakpoints initiate exception processing at the address in exception vector number 12, or alternately enter background mode.

5.11 Loop Mode Instruction Execution

The CPU32 has several features that provide efficient execution of program loops. One of these features is the DBcc looping primitive instruction. To increase the performance of the CPU32, a loop mode has been added to the processor. The loop mode is used by any single word instruction that does not change the program flow. Loop mode is implemented in conjunction with the DBcc instruction. **Figure 5-12** shows the required form of an instruction loop for the processor to enter loop mode.

5

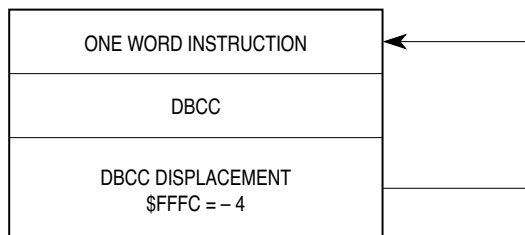

1126A

Figure 5-12 Loop Mode Instruction Sequence

The loop mode is entered when the DBcc instruction is executed, and the loop displacement is -4 . Once in loop mode, the processor performs only the data cycles associated with the instruction and suppresses all instruction fetches. The termination condition and count are checked after each execution of the data operations of the looped instruction. The CPU32 automatically exits the loop mode on interrupts or other exceptions. All single word instructions that do not cause a change of flow can be looped.



SECTION 6 QUEUED SERIAL MODULE

This section is an overview of queued serial module (QSM) function. Refer to the *QSM Reference Manual (QSMRM/AD)* for complete information about the QSM.

6.1 General

The QSM contains two serial interfaces, the queued serial peripheral interface (QSPI) and the serial communication interface (SCI). **Figure 6-1** is a block diagram of the QSM.

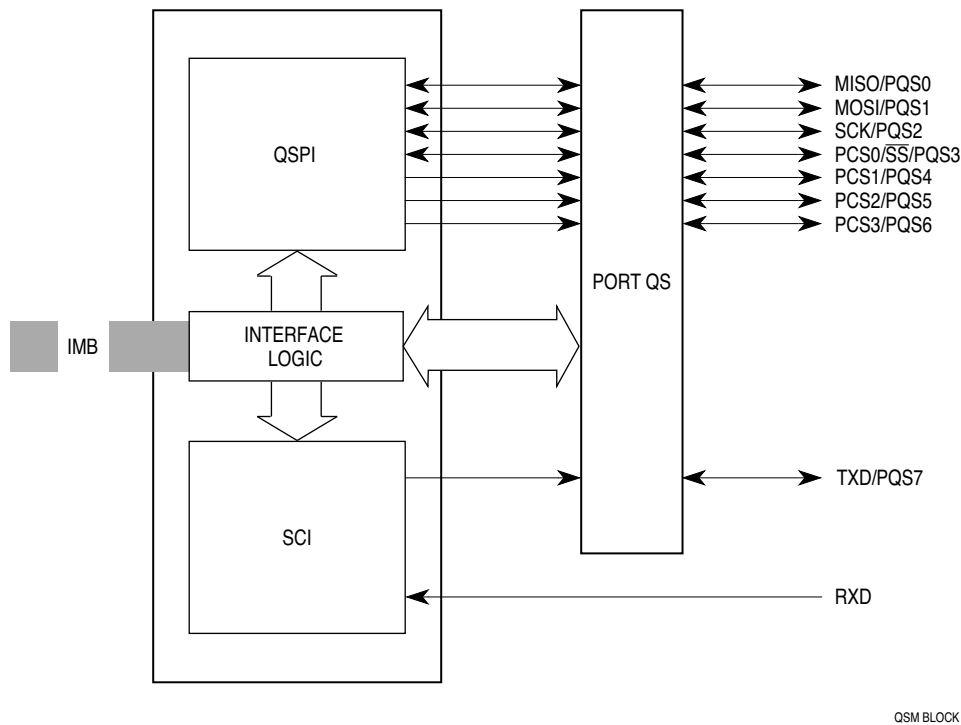

Figure 6-1 QSM Block Diagram

The QSPI provides easy peripheral expansion or interprocessor communication through a full-duplex, synchronous, three-line bus. Four programmable peripheral chip selects can select up to 16 peripheral devices. A self-contained RAM queue allows up to sixteen serial transfers of eight to sixteen bits each or transmission of a 256-bit data stream without CPU intervention. A special wraparound mode supports continuous sampling of a serial peripheral, with automatic QSPI RAM updating, for efficient interfacing to A/D converters.

The SCI provides a standard nonreturn to zero (NRZ) mark/space format. It will operate in either full- or half-duplex mode. There are separate transmitter and receiver enable bits and dual data buffers. A modulus-type baud rate generator provides rates from 64 to 524 kbaud with a 16.78-MHz system clock, or 110 to 655 kbaud with a 20.97-MHz system clock. Word length of either eight or nine bits can be selected. Optional parity generation and detection provide either even or odd parity check capability. Advanced error detection circuitry catches glitches of up to 1/16 of a bit time in duration. Wakeup functions allow the CPU to run uninterrupted until meaningful data is available.

6.2 QSM Registers and Address Map

There are four types of QSM registers: QSM global registers, QSM pin control registers, QSPI registers, and SCI registers. Global registers and pin control registers are discussed in **6.2.1 QSM Global Registers** and **6.2.2 QSM Pin Control Registers**. QSPI and SCI registers are discussed in **6.3 Queued Serial Peripheral Interface** and **6.4 Serial Communication Interface**. Writes to unimplemented register bits have no meaning or effect, and reads from unimplemented bits always return a logic zero value.

The QSM address map includes the QSM registers and the QSPI RAM. The module mapping (MM) bit in the SIM configuration register (SIMCR) defines the most significant bit (ADDR23) of the IMB address for each module in the MCU.

Refer to **APPENDIX D REGISTER SUMMARY** for a QSM address map and register bit/field definitions. **SECTION 4 SYSTEM INTEGRATION MODULE** contains more information about how the state of MM affects the system.

6.2.1 QSM Global Registers

The QSM configuration register (QSMCR) contains parameters for interfacing to the CPU32 and the intermodule bus. The QSM test register (QTEST) is used during factory test of the QSM. The QSM interrupt level register (QILR) interrupt level register (QILR) determines the priority of interrupts requested by the QSM and the vector used when an interrupt is acknowledged. The QSM interrupt vector register (QIVR) interrupt vector register (QIVR) contains the interrupt vector for both QSM submodules. QILR and QIVR are 8-bit registers located at the same word address. Refer to **APPENDIX D REGISTER SUMMARY** for register bit and field definitions.

6.2.1.1 Low-Power Stop Operation

When the STOP bit in the QSMCR is set, the system clock input to the QSM is disabled and the module enters a low-power operating state. QSMCR is the only register guaranteed to be readable while STOP is asserted. The QSPI RAM is not readable, but writes to RAM or any register are guaranteed valid while STOP is asserted. STOP can be set by the CPU and by reset.

System software must stop the QSPI and SCI before asserting STOP to prevent data corruption and simplify restart. Disable both SCI receiver and transmitter after transfers in progress are complete. Halt the QSPI by setting the HALT bit in SPCR3 and

then setting STOP after the HALTA flag is set. Refer to **SECTION 4 SYSTEM INTEGRATION MODULE** for more information about low-power operation.

6.2.1.2 Freeze Operation

The freeze (FRZ[1:0]) bits in the QSMCR are used to determine what action is taken by the QSM when the IMB FREEZE signal is asserted. FREEZE is asserted when the CPU enters background debugging mode. At the present time, FRZ0 has no effect; setting FRZ1 causes the QSPI to halt on the first transfer boundary following FREEZE assertion. Refer to **SECTION 5 CENTRAL PROCESSING UNIT** for more information about background debugging mode.

6.2.1.3 QSM Interrupts

Both the QSPI and SCI can make interrupt requests on the IMB. Each has a separate interrupt request priority register, but a single vector register is used to generate exception vector numbers.

The values of the ILQSPI and ILSCI fields in the QILR determine the priority of QSPI and SCI interrupt requests. The values in these fields correspond to internal interrupt request signals $\overline{\text{IRQ}}[7:1]$. A value of %111 causes $\overline{\text{IRQ}}7$ to be asserted when a QSM interrupt request is made; lower field values cause corresponding lower-numbered interrupt request signals to be asserted. Setting field value to %000 disables interrupts. If ILQSPI and ILSCI have the same nonzero value, and the QSPI and SCI make simultaneous interrupt requests, the QSPI has priority.

When the CPU32 acknowledges an interrupt request, it places the value in the interrupt priority (IP) mask in the CPU status register on the address bus. The QSM compares IP mask value to request priority to determine whether it should contend for arbitration priority. Arbitration priority is determined by the value of the IARB field in the QSMCR. Each module that generates interrupts must have a nonzero IARB value. Arbitration is performed by means of serial assertion of IARB field bit values.

When the QSM wins interrupt arbitration, it responds to the CPU interrupt acknowledge cycle by placing an interrupt vector number on the data bus. The vector number is used to calculate displacement into the CPU32 exception vector table. SCI and QSPI vector numbers are generated from the value in the QIVR INTV field. The values of bits INTV[7:1] are the same for QSPI and SCI, but the value of INTV0 is supplied by the QSM when an interrupt request is made. INTV0 = 0 for SCI interrupt requests; INTV0 = 1 for QSPI requests.

At reset, INTV is initialized to \$0F, the uninitialized interrupt vector number. To enable interrupt-driven serial communication, a user-defined vector number (\$40-\$FF) must be written to QIVR, and interrupt handler routines must be located at the addresses pointed to by the corresponding vector. CPU writes to INTV0 have no meaning or effect. Reads of INTV0 return a value of one.

Refer to **SECTION 5 CENTRAL PROCESSING UNIT** and **SECTION 4 SYSTEM INTEGRATION MODULE** for more information about exceptions and interrupts.

6.2.2 QSM Pin Control Registers

The QSM uses nine pins. Eight of the pins can be used for serial communication or for parallel I/O. Clearing a bit in the port QS pin assignment register (PQSPAR) assigns the corresponding pin to general-purpose I/O; setting a bit assigns the pin to the QSPI. PQSPAR does not affect operation of the SCI.

The port QS data direction register (DDRQS) determines whether pins are inputs or outputs. Clearing a bit makes the corresponding pin an input; setting a bit makes the pin an output. DDRQS affects both QSPI function and I/O function. DDQS1 determines the direction of the TXD pin only when the SCI transmitter is disabled. When the SCI transmitter is enabled, the TXD pin is an output. PQSPAR and DDRQS are 8-bit registers located at the same word address. **Table 6-1** is a summary of QSM pin functions.

The port QS data register (PORTQS) latches I/O data. Writes to PORTQS drive pins defined as outputs. PORTQS reads return data present on the pins when the read is made. To avoid driving undefined data, first write PORTQS, then configure DDRQS.

Table 6-1 QSM Pin Function

QSM Pin	Mode	DDRQS Bit	Bit State	Pin Function
MISO	Master	DDQS0	0	Serial Data Input to QSPI
			1	Disables Data Input
	Slave		0	Disables Data Output
			1	Serial Data Output from QSPI
MOSI	Master	DDQS1	0	Disables Data Output
			1	Serial Data Output from QSPI
	Slave		0	Serial Data Input to QSPI
			1	Disables Data Input
SCK ¹	Master	DDQS2	0	Disables Clock Output
			1	Clock Output from QSPI
	Slave		0	Clock Input to QSPI
			1	Disables Clock Input
PCS0/ \overline{SS}	Master	DDQS3	0	Assertion Causes Mode Fault
			1	Chip-Select Output
	Slave		0	QSPI Slave Select Input
			1	Disables Select Input
PCS[3:1]	Master	DDQS[4:6]	0	Disables Chip-Select Output
			1	Chip-Select Output
	Slave		0	Inactive
			1	Inactive
TXD ²	Transmit	DDQS7	X	Serial Data Output from SCI
RXD	Receive	None	NA	Serial Data Input to SCI

1. PQS2 is a digital I/O pin unless the SPI is enabled (SPE in SPCR1 set), in which case it becomes the SPI serial clock SCK.
2. PQS7 is a digital I/O pin unless the SCI transmitter is enabled (TE in SCCR1 set), in which case it becomes SCI serial output TXD and DDRQS has no effect.

6.3 Queued Serial Peripheral Interface

The queued serial peripheral interface (QSPI) communicates with external devices through a synchronous serial bus. The QSPI is fully compatible with SPI systems found on other Freescale products, but has enhanced capabilities. The QSPI can perform full duplex three-wire or half duplex two-wire transfers. A variety of transfer rate, clocking, and interrupt-driven communication options are available.

Serial transfer of any number of bits from eight to sixteen can be specified. Programmable transfer length simplifies interfacing to a number of devices that require different data lengths.

An inter-transfer delay of 17 to 8192 system clocks can be specified (default is 17 system clocks). Programmable delay simplifies the interface to a number of devices that require different delays between transfers.

A dedicated 80-byte RAM is used to store received data, data to be transmitted, and a queue of commands. The CPU can access these locations directly. Serial peripherals can be treated like memory-mapped parallel devices.

The command queue allows the QSPI to perform up to 16 serial transfers without CPU intervention. Each queue entry contains all the information needed by the QSPI to independently complete one serial transfer.

A pointer identifies the queue location containing the command for the next serial transfer. Normally, the pointer address is incremented after each serial transfer, but the CPU can change the pointer value at any time. Multiple-task support can be provided by segmenting the queue.

The QSPI has four peripheral chip-select pins. Chip-select signals simplify interfacing by reducing CPU intervention. If chip-select signals are externally decoded, 16 independent select signals can be generated. Each chip-select pin can drive up to four independent peripherals, depending on loading.

Wraparound operating mode allows continuous execution of queued commands. In wraparound mode, newly received data replaces previously received data in receive RAM. Wraparound can simplify the interface with A/D converters by continuously updating conversion values stored in the RAM.

Continuous transfer mode allows simultaneous transfer of an uninterrupted bit stream. Any number of bits in a range from 8 to 256 can be transferred without CPU intervention. Longer transfers are possible, but minimal CPU intervention is required to prevent loss of data. A standard delay of 17 system clocks is inserted between each queue entry transfer.

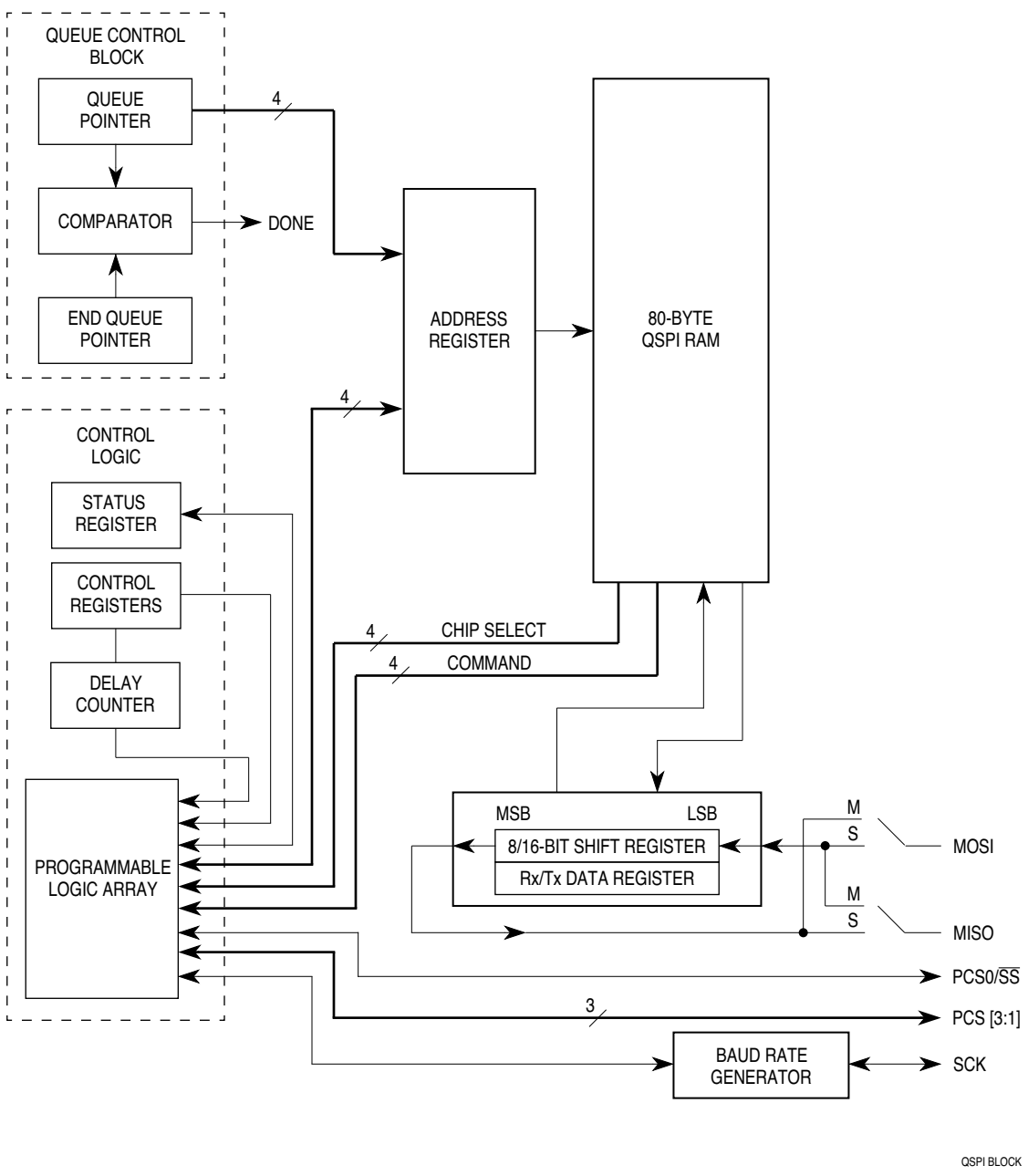

Figure 6-2 QSPI Block Diagram

6.3.1 QSPI Registers

The programmer's model for the QSPI consists of the QSM global and pin control registers, four QSPI control registers (SPCR[0:3]), a status register (SPCR), and the 80-byte QSPI RAM.

Registers and RAM can be read and written by the CPU. Refer to **APPENDIX D REGISTER SUMMARY** for register bit and field definitions.

6.3.1.1 Control Registers

Control registers contain parameters for configuring the QSPI and enabling various modes of operation. The CPU has read and write access to all control registers, but the QSM has read-only access to all bits except the SPE bit in SPCR1. Control registers must be initialized before the QSPI is enabled to ensure defined operation. SPCR1 must be written last because it contains the QSPI enable bit (SPE).

Writing a new value to any control register except SPCR2 while the QSPI is enabled disrupts operation. SPCR2 is buffered. New SPCR2 values become effective after completion of the current serial transfer. Rewriting NEWQP in SPCR2 causes execution to restart at the designated location. Reads of SPCR2 return the current value of the register, not of the buffer.

Writing the same value into any control register except SPCR2 while the QSPI is enabled has no effect on QSPI operation.

6.3.1.2 Status Register

The QSPI status register (SPSR) contains information concerning the current serial transmission. Only the QSPI can set the bits in this register. The CPU reads the SPSR to obtain QSPI status information and writes it to clear status flags.

6

6.3.2 QSPI RAM

The QSPI contains an 80-byte block of dual-access static RAM that can be accessed by both the QSPI and the CPU. The RAM is divided into three segments: receive data RAM, transmit data RAM, and command control data RAM. Receive data is information received from a serial device external to the MCU. Transmit data is information stored by the CPU for transmission to an external device. Command control data is used to perform transfers. Refer to **Figure 6-3**, which shows RAM organization.

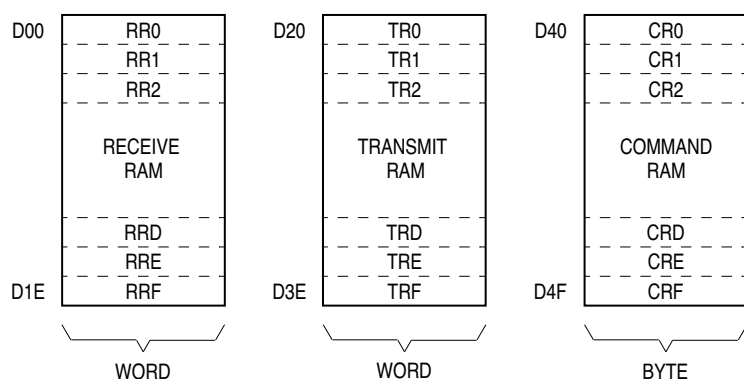

QSPI RAM MAP

Figure 6-3 QSPI RAM

6.3.2.1 Receive RAM

Data received by the QSPI is stored in this segment. The CPU reads this segment to retrieve data from the QSPI. Data stored in receive RAM is right-justified. Unused bits in a receive queue entry are set to zero by the QSPI upon completion of the individual queue entry. The CPU can access the data using byte, word, or long-word addressing.

The CPTQP value in SPSR shows which queue entries have been executed. The CPU uses this information to determine which locations in receive RAM contain valid data before reading them.

6.3.2.2 Transmit RAM

Data that is to be transmitted by the QSPI is stored in this segment. The CPU normally writes one word of data into this segment for each queue command to be executed.

Information to be transmitted must be written to transmit RAM in a right-justified format. The QSPI cannot modify information in the transmit RAM. The QSPI copies the information to its data serializer for transmission. Information remains in transmit RAM until overwritten.

6.3.2.3 Command RAM

Command RAM is used by the QSPI in master mode. The CPU writes one byte of control information to this segment for each QSPI command to be executed. The QSPI cannot modify information in command RAM.

Command RAM consists of 16 bytes. Each byte is divided into two fields. The peripheral chip-select field enables peripherals for transfer. The command control field provides transfer options.

A maximum of 16 commands can be in the queue. Queue execution by the QSPI proceeds from the address in NEWQP through the address in ENDQP (both of these fields are in SPCR2).

6.3.3 QSPI Pins

The QSPI uses seven pins. These pins can be configured for general-purpose I/O when not needed for QSPI application. When used for QSPI functions, the MOSI, MISO, and \overline{SS} pins should have pull-up resistors.

Table 6-2 shows QSPI input and output pins and their functions.

Table 6-2 QSPI Pin Function

Pin/Signal Name	Mnemonic	Mode	Function
Master In Slave Out	MISO	Master Slave	Serial Data Input to QSPI Serial Data Output from QSPI
Master Out Slave In	MOSI	Master Slave	Serial Data Output from QSPI Serial Data Input to QSPI
Serial Clock	SCK	Master Slave	Clock Output from QSPI Clock Input to QSPI
Peripheral Chip Selects	PCS[3:1]	Master	Select Peripherals
Slave Select	\overline{SS}	Master Slave	Causes Mode Fault
Peripheral Chip Select 0	PCS0	Master	Initiates Serial Transfer Selects Peripherals

6.3.4 QSPI Operation

The QSPI uses a dedicated 80-byte block of static RAM accessible by both the QSPI and the CPU to perform queued operations. The RAM is divided into three segments. There are 16 command control bytes, 16 transmit data words, and 16 receive data words. QSPI RAM is organized so that one byte of command control data, one word of transmit data, and one word of receive data correspond to one queue entry, \$0–\$F.

The CPU initiates QSPI operation by setting up a queue of QSPI commands in command RAM, writing transmit data into transmit RAM, then enabling the QSPI. The QSPI executes the queued commands, sets a completion flag (SPIF), and then either interrupts the CPU or waits for CPU intervention.

There are four queue pointers. The CPU can access three of them through fields in QSPI registers. The new queue pointer (NEWQP), in SPCR2, points to the first command in the queue. An internal queue pointer points to the command currently being executed. The completed queue pointer (CPTQP), in SPSR, points to the last command executed. The end queue pointer (ENDQP), contained in SPCR2, points to the final command in the queue.

The internal pointer is initialized to the same value as NEWQP. During normal operation, the command pointed to by the internal pointer is executed, the value in the internal pointer is copied into CPTQP, the internal pointer is incremented, and then the sequence repeats. Execution continues at the internal pointer address unless the NEWQP value is changed. After each command is executed, ENDQP and CPTQP are compared. When a match occurs, the SPIF flag is set and the QSPI stops unless wrap-around mode is enabled.

At reset, NEWQP is initialized to \$0. When the QSPI is enabled, execution begins at queue address \$0 unless another value has been written into NEWQP. ENDQP is initialized to \$0 at reset, but should be changed to show the last queue entry before the QSPI is enabled. NEWQP and ENDQP can be written at any time. When the NEWQP value changes, the internal pointer value also changes. However, if NEWQP is written while a transfer is in progress, the transfer is completed normally. Leaving NEWQP and ENDQP set to \$0 causes a single transfer to occur when the QSPI is enabled.

6.3.5 QSPI Operating Modes

The QSPI operates in either master or slave mode. Master mode is used when the MCU originates data transfers. Slave mode is used when an external device initiates serial transfers to the MCU through the QSPI. Switching between the modes is controlled by MSTR in SPCR0. Before either mode is entered, appropriate QSM and QSPI registers must be initialized properly.

In master mode, the QSPI executes a queue of commands defined by control bits in each command RAM queue entry. Chip-select pins are activated, data is transmitted from transmit RAM and received by the receive RAM.

In slave mode, operation proceeds in response to \overline{SS} pin activation by an external bus master. Operation is similar to master mode, but no peripheral chip selects are generated, and the number of bits transferred is controlled in a different manner. When the QSPI is selected, it automatically executes the next queue transfer to exchange data with the external device correctly.

Although the QSPI inherently supports multimaster operation no special arbitration mechanism is provided. A mode fault flag (MODF) indicates a request for SPI master arbitration. System software must provide arbitration. Note that unlike previous SPI systems, MSTR is not cleared by a mode fault being set nor are the QSPI pin output drivers disabled. The QSPI and associated output drivers must be disabled by clearing SPE in SPCR1.

Figure 6-4 shows QSPI initialization; **Figure 6-5** and **Figure 6-6** show QSPI master and slave operation. The CPU must initialize the QSM global and pin registers and the QSPI control registers before enabling the QSPI for either mode of operation (refer to **6.5 QSM Initialization**). The command queue must be written before the QSPI is enabled for master mode operation. Any data to be transmitted should be written into transmit RAM before the QSPI is enabled. During wraparound operation, data for subsequent transmissions can be written at any time.

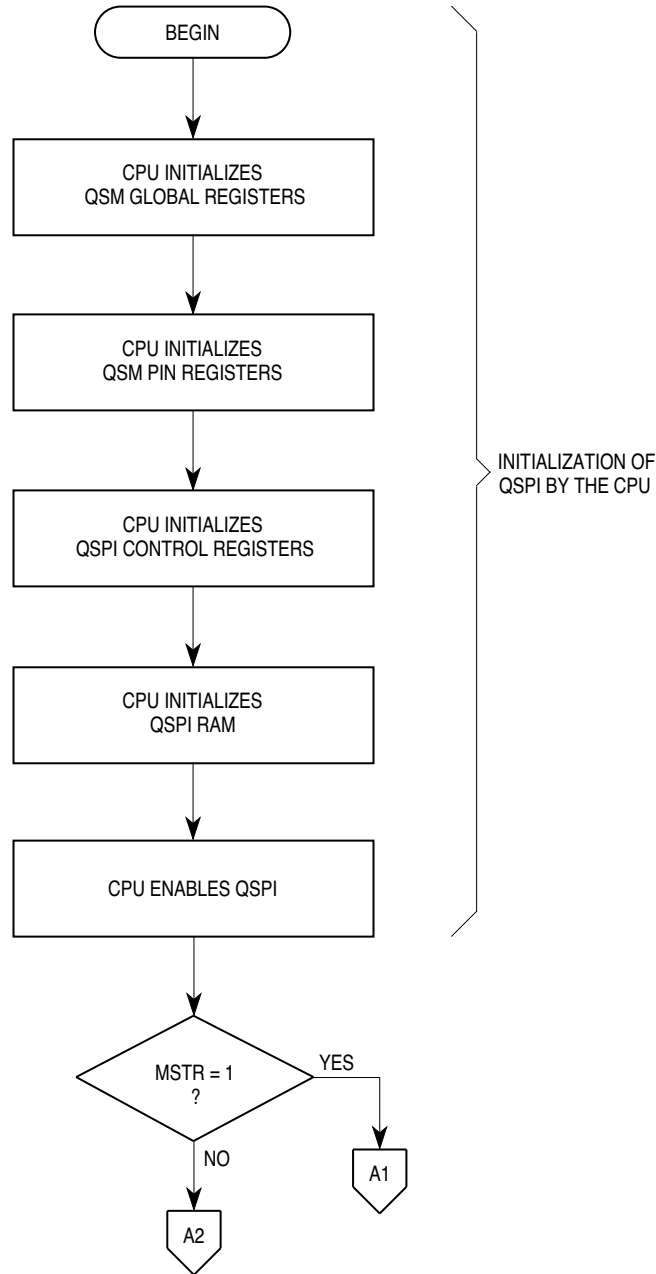

QSPI FLOW 1

Figure 6-4 Flowchart of QSPI Initialization Operation

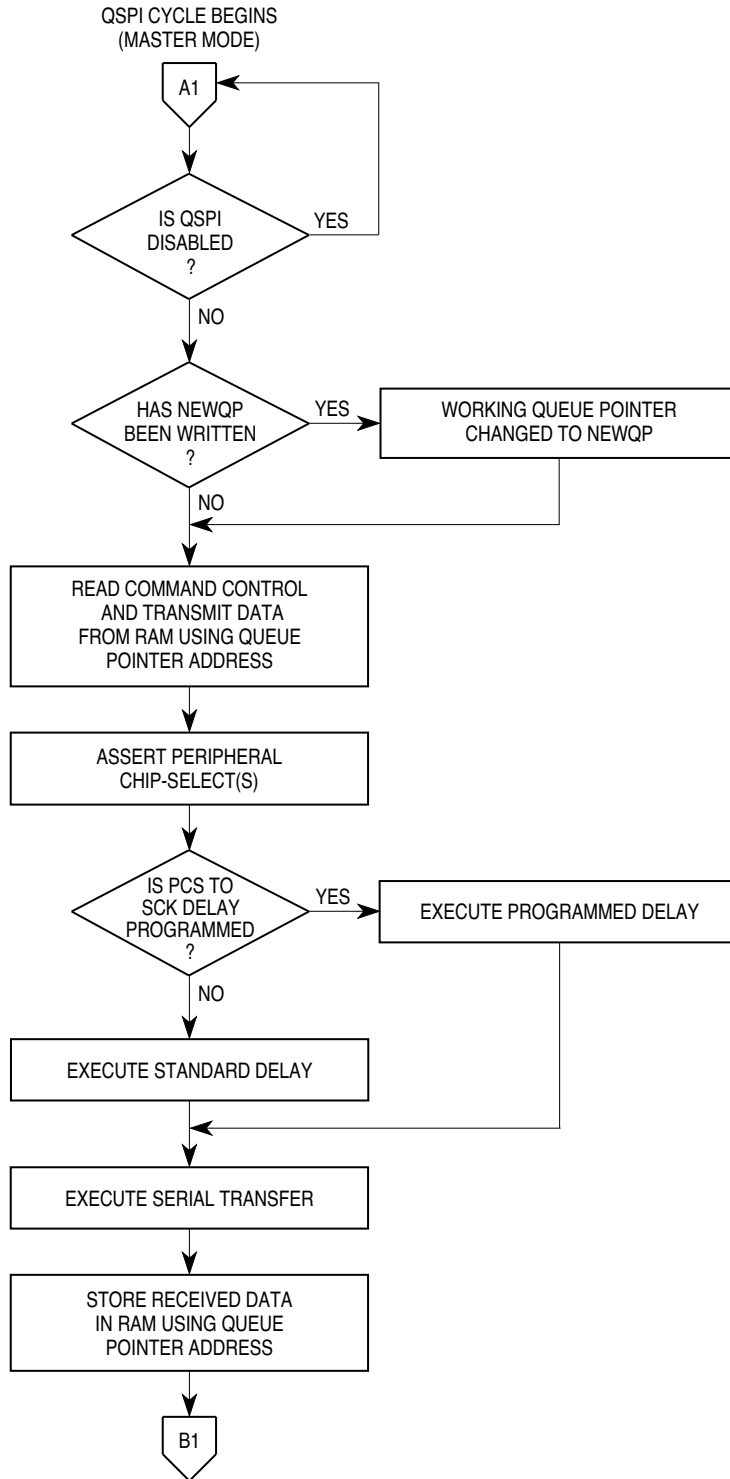

QSPI FLOW 2

Figure 6-5 Flowchart of QSPI Master Operation (Part 1)

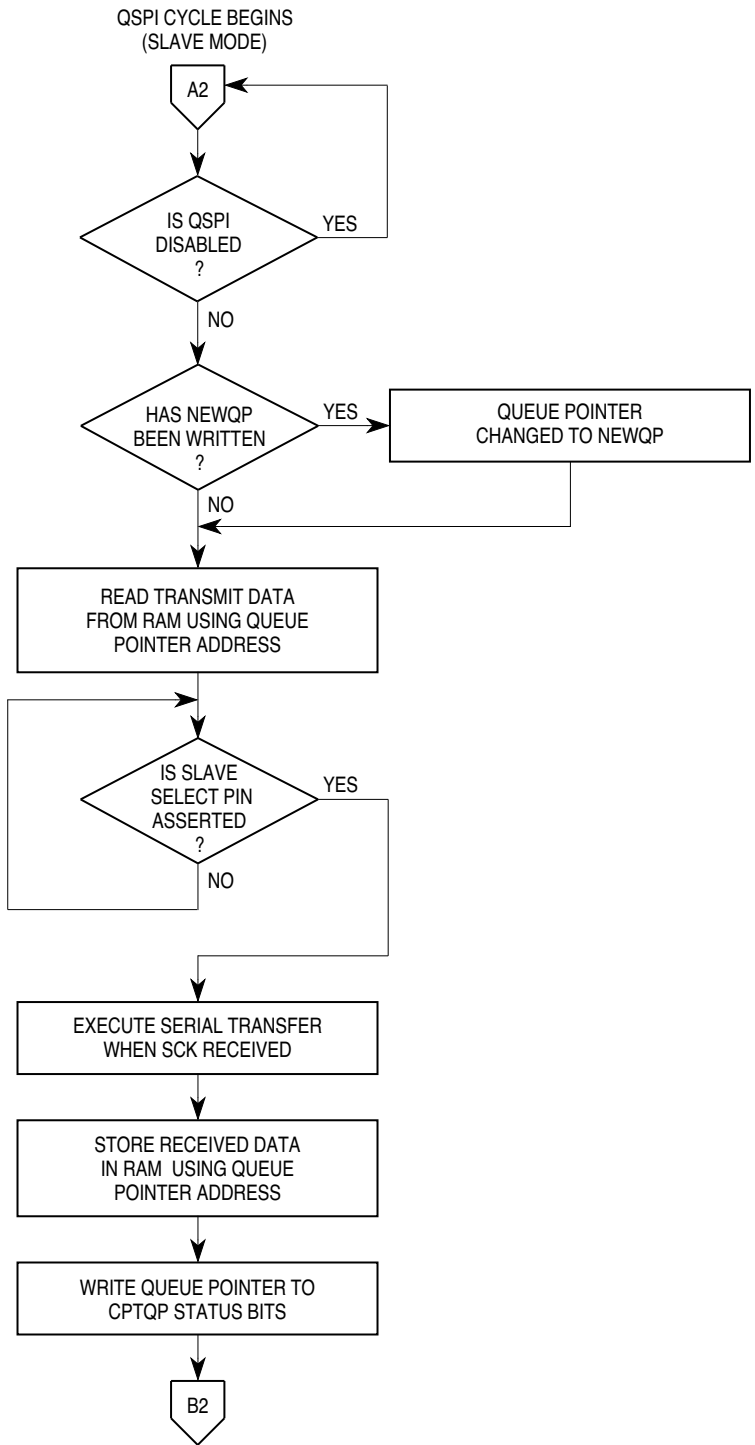

QSPI FLOW 3

Figure 6-5 Flowchart of QSPI Master Operation (Part 2)

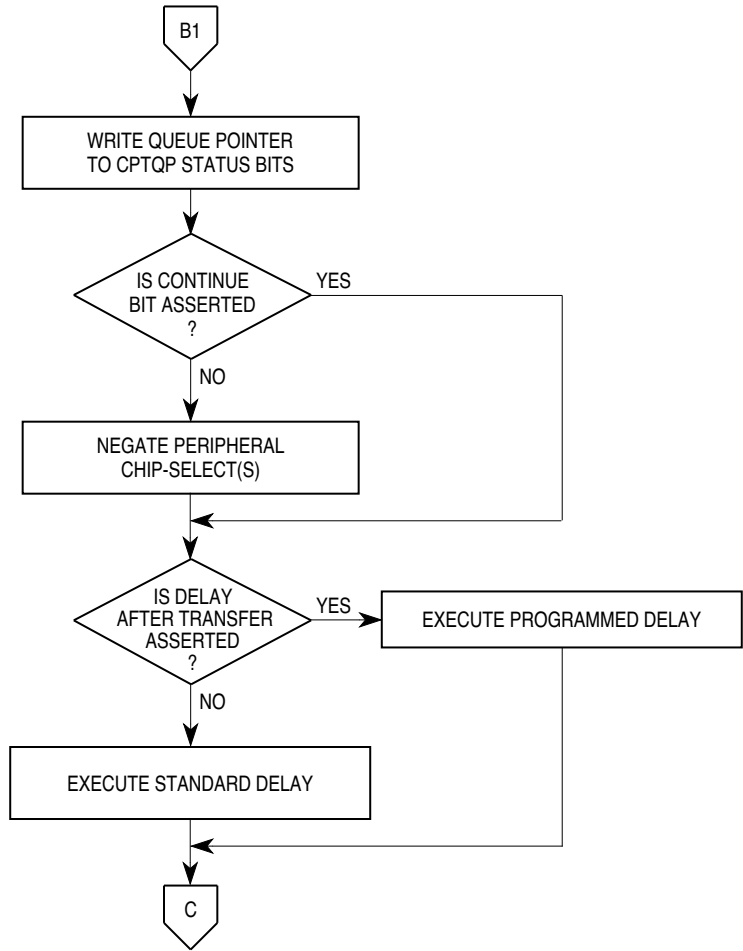

QSPI FLOW 4

Figure 6-5 Flowchart of QSPI Master Operation (Part 3)

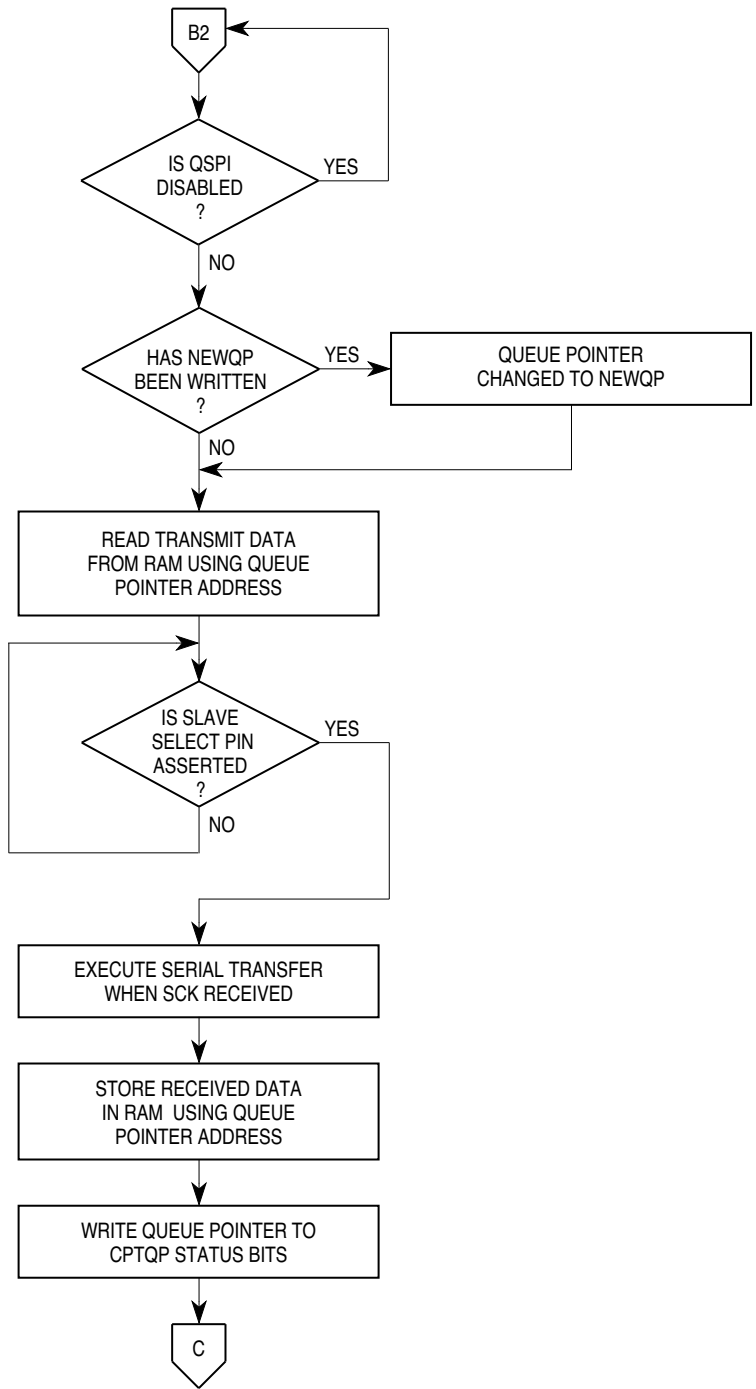

QSPI FLOW 5

Figure 6-6 Flowchart of QSPI Slave Operation (Part 1)

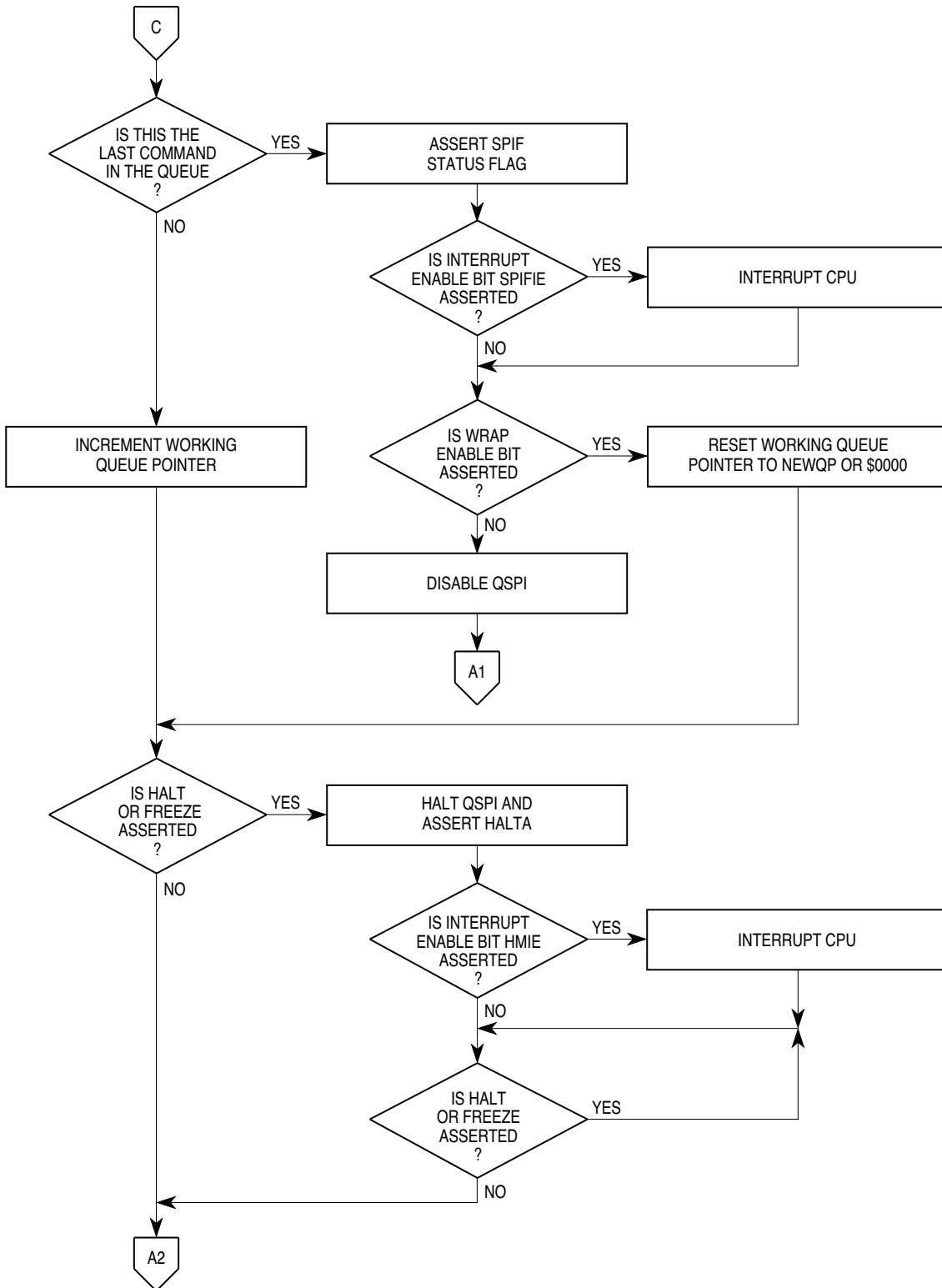

QSPI FLOW 6

Figure 6-6 Flowchart of QSPI Slave Operation (Part 2)

Normally, the SPI bus performs synchronous bidirectional transfers. The serial clock on the SPI bus master supplies the clock signal (SCK) to time the transfer of data. Four possible combinations of clock phase and polarity can be specified by the CPHA and CPOL bits in SPCR0.

Data is transferred with the most significant bit first. The number of bits transferred per command defaults to eight, but can be set to any value from eight to sixteen bits by writing a value into the BITSE field in command RAM.

Typically, SPI bus outputs are not open-drain unless multiple SPI masters are in the system. If needed, the WOMQ bit in SPCR0 can be set to provide wired-OR, open-drain outputs. An external pull-up resistor should be used on each output line. WOMQ affects all QSPI pins regardless of whether they are assigned to the QSPI or used as general-purpose I/O.

6.3.5.1 Master Mode

Setting the MSTR bit in SPCR0 selects master mode operation. In master mode, the QSPI can initiate serial transfers, but cannot respond to externally initiated transfers. When the slave select input of a device configured for master mode is asserted, a mode fault occurs.

Before QSPI operation is initiated, QSM register PQSPAR must be written to assign necessary pins to the QSPI. The pins necessary for master mode operation are MISO and MOSI, SCK, and one or more of the chip-select pins. MISO is used for serial data input in master mode, and MOSI is used for serial data output. Either or both may be necessary, depending on the particular application. SCK is the serial clock output in master mode.

Before master mode operation is initiated, QSM register DDRQS must be written to direct the data flow on the QSPI pins used. Configure the SCK, MOSI and appropriate chip-select pins PCS[3:0]/SS as outputs. The MISO pin must be configured as an input.

After pins are assigned and configured, write appropriate data to the command queue. If data is to be transmitted, write the data to transmit RAM. Initialize the queue pointers as appropriate.

Data transfer is synchronized with the internally-generated serial clock (SCK). Control bits, CPHA and CPOL, in SPCR0, control clock phase and polarity. Combinations of CPHA and CPOL determine upon which SCK edge to drive outgoing data from the MOSI pin and to latch incoming data from the MISO pin.

Baud rate is selected by writing a value from 2 to 255 into the SPBR field in SPCR0. The QSPI uses a modulus counter to derive SCK baud rate from the MCU system clock.

The following expressions apply to SCK baud rate:

$$\text{SCK Baud Rate} = \frac{\text{System Clock}}{2 \times \text{SPBR}}$$

or

$$SPBR = \frac{\text{System Clock}}{(2 \times SCK) \times (\text{Baud Rate Desired})}$$

Giving SPBR a value of zero or one disables the baud rate generator. SCK is disabled and assumes its inactive state value.

The DSCK field in command RAM determines the delay period from chip-select assertion until the leading edge of the serial clock. The DSCKL field in SPCR1 determines the period of delay before the assertion of SCK. The following expression determines the actual delay before SCK:

$$\text{PCS to SCK Delay} = \frac{\text{DSCKL}}{\text{System Clock Frequency}}$$

where DSCKL equals {1, 2, 3,..., 127}.

When DSCK equals zero, DSCKL is not used. Instead, the PCS valid-to-SCK transition is one-half the DSCK period.

There are two transfer length options. The user can choose a default value of eight bits, or a programmed value of eight to sixteen bits, inclusive. The programmed value must be written into the BITS field in SPCR0. The BITSE field in command RAM determines whether the default value (BITSE = 0) or the BITS value (BITSE = 1) is used. **Table 6-3** shows BITS field encoding.

Table 6-3 BITS Encoding

BITS	Bits per Transfer
0000	16
0001	Reserved
0010	Reserved
0011	Reserved
0100	Reserved
0101	Reserved
0110	Reserved
0111	Reserved
1000	8
1001	9
1010	10
1011	11
1100	12
1101	13
1110	14
1111	15

Delay after transfer can be used to provide a peripheral deselect interval. A delay can also be inserted between consecutive transfers to allow serial A/D converters to complete conversion. There are two transfer delay options. The user can choose to delay a standard period after serial transfer is complete or can specify a delay period. Writing a value to the DTL field in SPCR1 specifies a delay period. The DT bit in command RAM determines whether the standard delay period (DT = 0) or the specified delay pe-

riod (DT = 1) is used. The following expression is used to calculate the delay:

$$\text{Delay after Transfer} = \frac{32 \times \text{DTL}}{\text{System Clock Frequency}}$$

where DTL equals {1, 2, 3,..., 255}.

A zero value for DTL causes a delay-after-transfer value of 8192/system clock.

$$\text{Standard Delay after Transfer} = \frac{17}{\text{System Clock}}$$

Adequate delay between transfers must be specified for long data streams because the QSPI requires time to load a transmit RAM entry for transfer. Receiving devices need at least the standard delay between successive transfers. If the system clock is operating at a slower rate, the delay between transfers must be increased proportionately.

Operation is initiated by setting the SPE bit in SPCR1. Shortly after SPE is set, the QSPI executes the command at the command RAM address pointed to by NEWQP. Data at the pointer address in transmit RAM is loaded into the data serializer and transmitted. Data that is simultaneously received is stored at the pointer address in receive RAM.

When the proper number of bits have been transferred, the QSPI stores the working queue pointer value in CPTQP, increments the working queue pointer, and loads the next data for transfer from transmit RAM. The command pointed to by the incremented working queue pointer is executed next, unless a new value has been written to NEWQP. If a new queue pointer value is written while a transfer is in progress, that transfer is completed normally.

When the CONT bit in command RAM is set, PCS pins are continuously driven in specified states during and between transfers. If the chip-select pattern changes during or between transfers, the original pattern is driven until execution of the following transfer begins. When CONT is cleared, the data in register PORTQS is driven between transfers.

When the QSPI reaches the end of the queue, it sets the SPIF flag. If the SPIFIE bit in SPCR2 is set, an interrupt request is generated when SPIF is asserted. At this point, the QSPI clears SPE and stops unless wraparound mode is enabled.

6.3.5.2 Master Wraparound Mode

Wraparound mode is enabled by setting the WREN bit in SPCR2. The queue can wrap to pointer address \$0 or to the address pointed to by NEWQP, depending on the state of the WRTO bit in SPCR2.

In wraparound mode, the QSPI cycles through the queue continuously, even while the QSPI is requesting interrupt service. SPE is not cleared when the last command in the queue is executed. New receive data overwrites previously received data in receive RAM. Each time the end of the queue is reached, the SPIF flag is set. SPIF is not automatically reset. If interrupt-driven SPI service is used, the service routine must clear the SPIF bit to abort the current request. Additional interrupt requests during servicing

can be prevented by clearing SPIFIE, but SPIFIE is buffered. Clearing it does not abort a current request.

There are two recommended methods of exiting wraparound mode: clearing the WREN bit or setting the HALT bit in SPCR3. Exiting wraparound mode by clearing SPE is not recommended, as clearing SPE may abort a serial transfer in progress. The QSPI sets SPIF, clears SPE, and stops the first time it reaches the end of the queue after WREN is cleared. After HALT is set, the QSPI finishes the current transfer, then stops executing commands. After the QSPI stops, SPE can be cleared.

6.3.5.3 Slave Mode

Clearing the MSTR bit in SPCR0 selects slave mode operation. In slave mode, the QSPI is unable to initiate serial transfers. Transfers are initiated by an external bus master. Slave mode is typically used on a multi-master SPI bus. Only one device can be bus master (operate in master mode) at any given time.

Before QSPI operation is initiated, QSM register PQSPAR must be written to assign necessary pins to the QSPI. The pins necessary for slave mode operation are MISO and MOSI, SCK, and PCS0/ \overline{SS} . MISO is used for serial data output in slave mode, and MOSI is used for serial data input. Either or both may be necessary, depending on the particular application. SCK is the serial clock input in slave mode. Assertion of the active-low slave select signal (\overline{SS}) initiates slave mode operation.

Before slave mode operation is initiated, DDRQS must be written to direct data flow on the QSPI pins used. Configure the MOSI, SCK and PCS0/ \overline{SS} pins as inputs. The MISO pin must be configured as an output.

After pins are assigned and configured, write data to be transmitted into transmit RAM. Command RAM is not used in slave mode and does not need to be initialized. Unused portions of QSPI RAM can be used by the CPU as general-purpose RAM. Initialize the queue pointers as appropriate.

When SPE is set and MSTR is clear, a low state on the slave select (PCS0/ \overline{SS}) pin begins slave mode operation at the address indicated by NEWQP. Data that is received is stored at the pointer address in receive RAM. Data is simultaneously loaded into the data serializer from the pointer address in transmit RAM and transmitted. Transfer is synchronized with the externally generated SCK. The CPHA and CPOL bits determine on which SCK edge to latch incoming data from the MISO pin and to drive outgoing data from the MOSI pin.

Because the command control segment is not used, the command control bits and peripheral chip-select codes have no effect in slave mode operation. The PCS0/ \overline{SS} pin is used only as an input.

The SPBR, DT and DSCK bits are not used in slave mode. The QSPI drives neither the clock nor the chip-select pins and thus cannot control clock rate or transfer delay.

Because the BITSE option is not available in slave mode, the BITS field specifies the number of bits to be transferred for all transfers in the queue. When the number of bits

designated by BITS has been transferred, the QSPI stores the working queue pointer value in CPTQP, increments the working queue pointer, and loads new transmit data from transmit RAM into the data serializer. The working queue pointer address is used the next time PCS0/ \overline{SS} is asserted, unless the CPU writes to NEWQP first.

The QSPI shifts one bit for each pulse of SCK until the slave select input goes high. If \overline{SS} goes high before the number of bits specified by the BITS field is transferred, the QSPI resumes operation at the same pointer address the next time \overline{SS} is asserted. The maximum value that the BITS field can have is 16. If more than 16 bits are transmitted before \overline{SS} is negated, pointers are incremented and operation continues. The QSPI transmits as many bits as it receives at each queue address, until the BITS value is reached or \overline{SS} is negated. \overline{SS} does not need to go high between transfers as the QSPI transfers data until reaching the end of the queue, whether \overline{SS} remains low or is toggled between transfers.

When the QSPI reaches the end of the queue, it sets the SPIF flag. If the SPIFIE bit in SPCR2 is set, an interrupt request is generated when SPIF is asserted. At this point, the QSPI clears SPE and stops unless wraparound mode is enabled.

6.3.5.4 Slave Wraparound Mode

Slave wraparound mode is enabled by setting the WREN bit in SPCR2. The queue can wrap to pointer address \$0 or to the address pointed to by NEWQP, depending on the state of the WRTO bit in SPCR2. Slave wraparound operation is identical to master wraparound operation.

6.3.6 Peripheral Chip Selects

Peripheral chip-select signals are used to select an external device for serial data transfer. Chip-select signals are asserted when a command in the queue is executed. Signals are asserted at a logic level corresponding to the value of the PCS bits in the command. More than one chip-select signal can be asserted at a time, and more than one external device can be connected to each PCS pin, provided proper fanout is observed. PCS0 shares a pin with the slave select (\overline{SS}) signal, which initiates slave mode serial transfer. If \overline{SS} is taken low when the QSPI is in master mode, a mode fault occurs.

To set up a chip-select function, set the appropriate bit in PQSPAR, then configure the chip-select pin as an output by setting the appropriate bit in DDRQS. The value of the bit in PORTQS that corresponds to the chip-select pin determines the base state of the chip-select signal. If base state is zero, chip-select assertion must be active high (PCS bit in command RAM must be set); if base state is one, assertion must be active low (PCS bit in command RAM must be cleared). PORTQS bits are cleared during reset. If no new data is written to PORTQS before pin assignment and configuration as an output, base state of chip-select signals is zero and chip-select pins are configured for active-high operation.

6.4 Serial Communication Interface

The serial communication interface (SCI) communicates with external devices through an asynchronous serial bus. The SCI uses a standard nonreturn to zero (NRZ) transmission format. The SCI is fully compatible with other Freescale SCI systems, such as those in M68HC11 and M68HC05 devices. **Figure 6-7** is a block diagram of the SCI transmitter; **Figure 6-8** is a block diagram of the SCI receiver.

6.4.1 SCI Registers

The SCI programming model includes the QSM global and pin control registers, and four SCI registers. There are two SCI control registers (SCCR0 and SCCR1), one status register (SCSR), and one data register (SCDR). Refer to **APPENDIX D REGISTER SUMMARY** for register bit and field definition.

6.4.1.1 Control Registers

SCCR0 contains the baud rate selection field. Baud rate must be set before the SCI is enabled. The CPU can read and write this register at any time.

SCCR1 contains a number of SCI configuration parameters, including transmitter and receiver enable bits, interrupt enable bits, and operating mode enable bits. The CPU can read and write this register at any time. The SCI can modify the RWU bit under certain circumstances.

Changing the value of SCI control bits during a transfer operation may disrupt operation. Before changing register values, allow the SCI to complete the current transfer, then disable the receiver and transmitter.

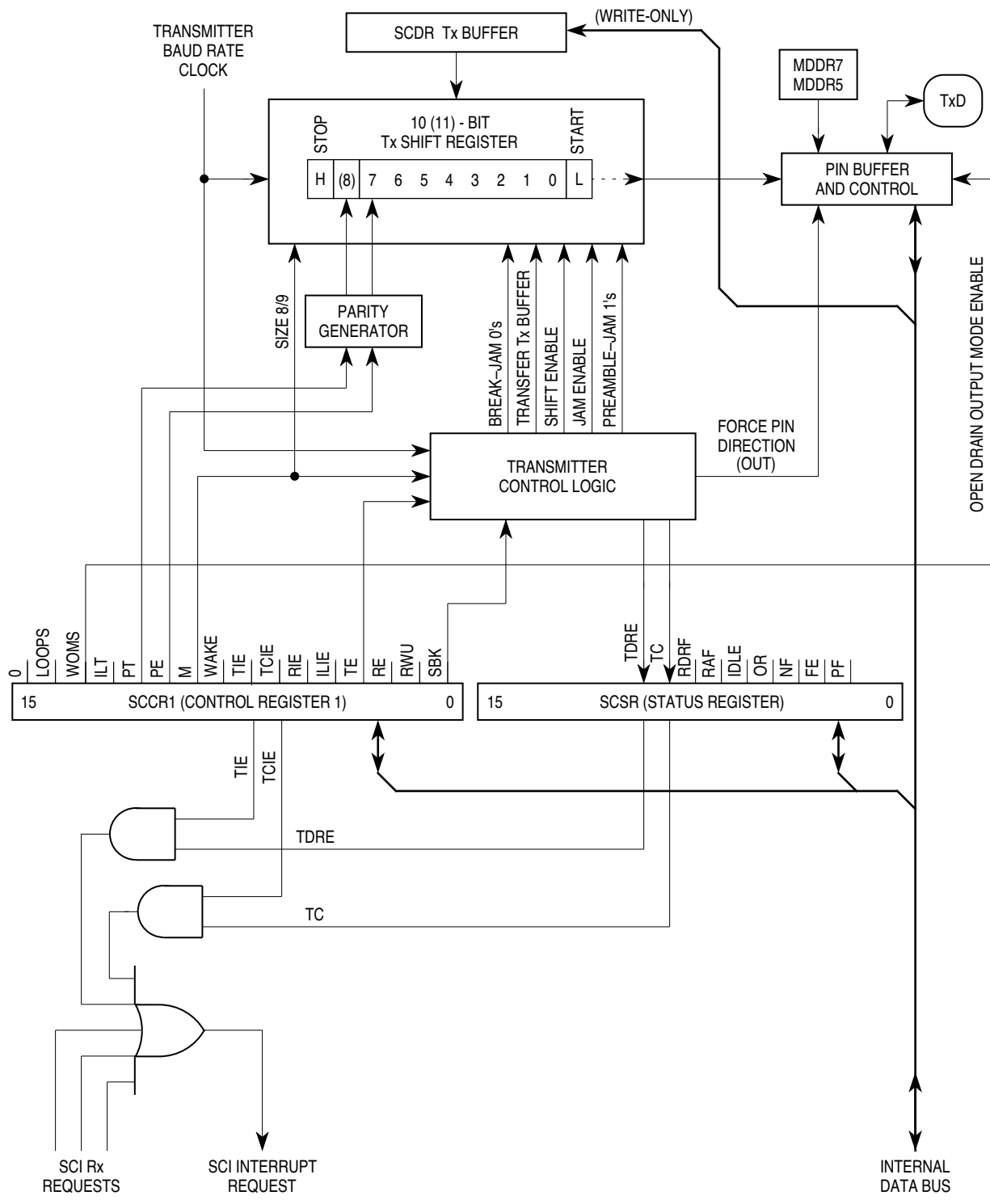

6

68300 SCI TX BLOCK

Figure 6-7 SCI Transmitter Block Diagram

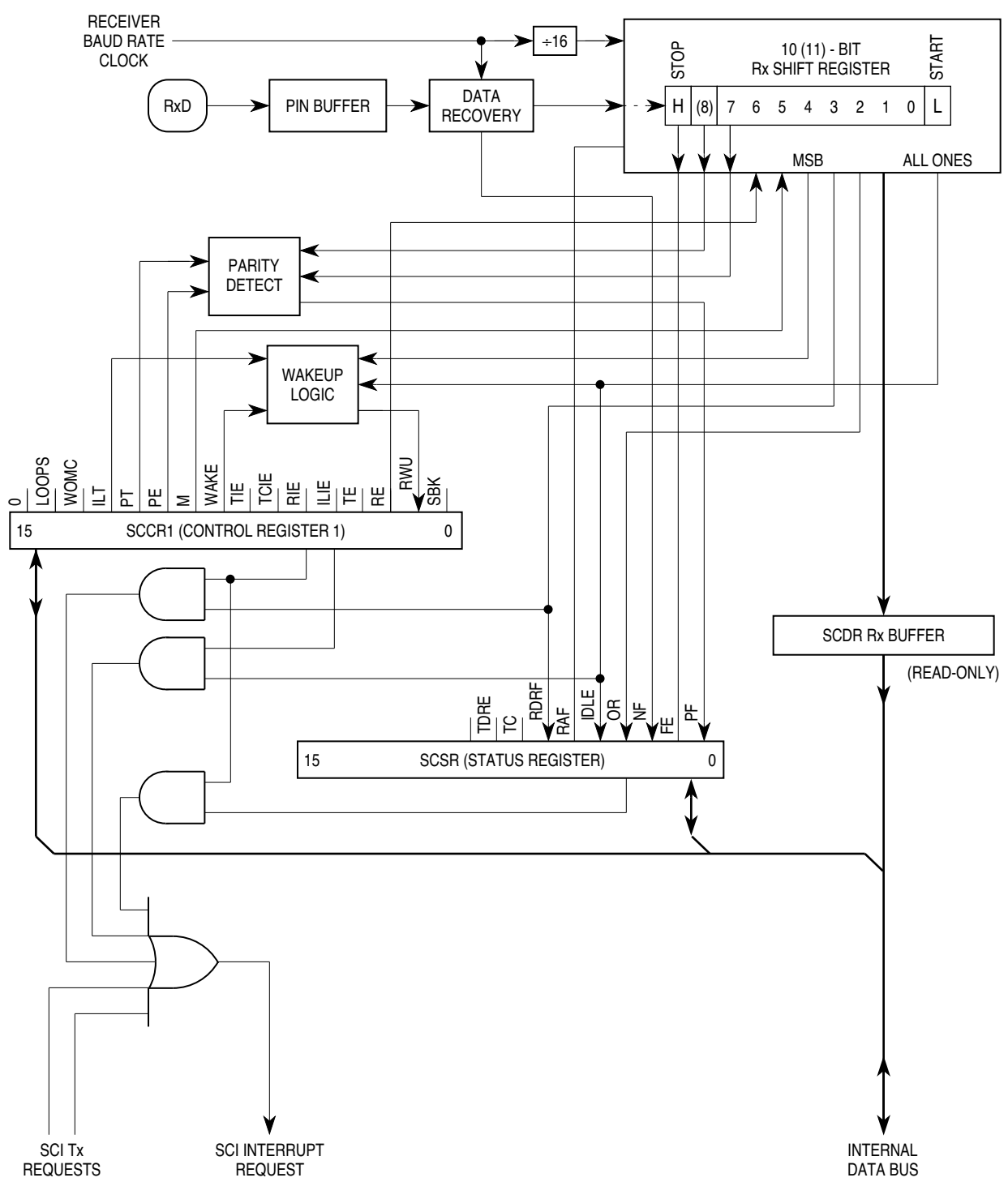

68300 SCI RX BLOCK

Figure 6-8 SCI Receiver Block Diagram

6.4.1.2 Status Register

The SCI status register (SCSR) contains flags that show SCI operating conditions. These flags are cleared either by SCI hardware or by a read/write sequence. In general, flags are cleared by reading the SCSR, then reading (receiver status bits) or writing (transmitter status bits) the SCDR. A long-word read can consecutively access both the SCSR and SCDR. This action clears receive status flag bits that were set at the time of the read, but does not clear TDRE or TC flags.

If an internal SCI signal for setting a status bit comes after the CPU has read the asserted status bits, but before the CPU has written or read the SCDR, the newly set status bit is not cleared. The SCSR must be read again with the bit set, and the SCDR must be written or read before the status bit is cleared.

Reading either byte of the SCSR causes all 16 bits to be accessed, and any status bit already set in either byte is cleared on a subsequent read or write of the SCDR.

6.4.1.3 Data Register

The SCDR contains two data registers at the same address. The RDR is a read-only register that contains data received by the SCI serial interface. The data comes into the receive serial shifter and is transferred to the RDR. The TDR is a write-only register that contains data to be transmitted. The data is first written to the TDR, then transferred to the transmit serial shifter, where additional format bits are added before transmission. R[7:0]/T[7:0] contain either the first eight data bits received when the SCDR is read, or the first eight data bits to be transmitted when the SCDR is written. R8/T8 are used when the SCI is configured for 9-bit operation. When it is configured for 8-bit operation, they have no meaning or effect.

6.4.2 SCI Pins

Two unidirectional pins, TXD (transmit data) and RXD (receive data), are associated with the SCI. TXD can be used by the SCI or for general-purpose I/O. Function is assigned by the port QS pin assignment register (PQSPAR). The receive data (RXD) pin is dedicated to the SCI. **Table 6-4** shows SCI pin function.

Table 6-4 SCI Pin Function

Pin Names	Mnemonics	Mode	Function
Receive Data	RXD	Receiver Disabled	Not Used
		Receiver Enabled	Serial Data Input to SCI
Transmit Data	TXD	Transmitter Disabled	General-Purpose I/O
		Transmitter Enabled	Serial Data Output from SCI

6.4.3 SCI Operation

SCI status flags in the SPSR support polled operation, or interrupt-driven operation can be employed by the interrupt enable bits in SCCR1.

6.4.3.1 Definition of Terms

Bit-Time — The time required to transmit or receive one bit of data; one cycle of the baud frequency.

Start Bit — One bit-time of logic zero that indicates the beginning of a data frame. A start bit must begin with a one-to-zero transition and be preceded by at least three receive time (RT) samples of logic one.

Stop Bit — One bit-time of logic one that indicates the end of a data frame.

Frame — A complete unit of serial information. The SCI can use 10-bit or 11-bit frames.

Data Frame — A start bit, a specified number of data or information bits, and at least one stop bit.

Idle Frame — A frame that consists of consecutive ones. An idle frame has no start bit.

Break Frame — A frame that consists of consecutive zeros. A break frame has no stop bits.

6.4.3.2 Serial Formats

All data frames must have a start bit and at least one stop bit. Receiving and transmitting devices must use the same data frame format. The SCI provides hardware support for both ten-bit and eleven-bit frames. The serial mode (M) bit in SCI control register one (SCCR1) specifies the number of bits per frame.

The most common ten-bit data frame format for NRZ serial interface consists of one start bit, eight data bits (LSB first), and one stop bit. The most common eleven-bit data frame contains one start bit, eight data bits, a parity or control bit, and one stop bit. Ten-bit and eleven-bit frames are shown in **Table 6-5**.

Table 6-5 Serial Frame Formats

10-Bit Frames			
Start	Data	Parity/Control	Stop
1	7	—	2
1	7	1	1
1	8	—	1
11-Bit Frames			
Start	Data	Parity/Control	Stop
1	7	1	2
1	8	1	1

6.4.3.3 Baud Clock

The SCI baud clock is programmed by writing a 13-bit value to the baud rate (SCBR) field in SCI control register zero (SCCR0). Baud clock is derived from the MCU system clock by a modulus counter. Writing a value of zero to SCBR disables the baud rate generator. Baud clock rate is calculated as follows:

$$\text{SCI Baud Clock Rate} = \frac{\text{System Clock}}{32 \times \text{SCBR}}$$

where SCBR is in the range {1, 2, 3,..., 8191}.

The SCI receiver operates asynchronously. An internal clock is necessary to synchronize with an incoming data stream. The SCI baud clock generator produces a receive time (RT) sampling clock with a frequency 16 times that of the SCI baud clock. The SCI determines the position of bit boundaries from transitions within the received waveform, and adjusts sampling points to the proper positions within the bit period.

6.4.3.4 Parity Checking

The parity type (PT) bit in SCCR1 selects either even (PT = 0) or odd (PT = 1) parity. PT affects received and transmitted data. The parity enable (PE) bit in SCCR1 determines whether parity checking is enabled (PE = 1) or disabled (PE = 0). When PE is set, the MSB of the data in a frame is used for the parity function. For transmitted data, a parity bit is generated; for received data, the parity bit is checked. When parity checking is enabled, the parity flag (PF) in the SCI status register (SCSR) is set if a parity error is detected.

Enabling parity affects the number of data bits in a frame, which can in turn affect frame size. **Table 6-6** shows possible data and parity formats.

Table 6-6 Effect of Parity Checking on Data Size

M	PE	Result
0	0	8 Data Bits
0	1	7 Data Bits, 1 Parity Bit
1	0	9 Data Bits
1	1	8 Data Bits, 1 Parity Bit

6.4.3.5 Transmitter Operation

The transmitter consists of a serial shifter and a parallel data register (TDR) located in the SCI data register (SCDR). The serial shifter cannot be directly accessed by the CPU. The transmitter is double-buffered, which means that data can be loaded into the TDR while other data is shifted out. The transmitter enable (TE) bit in SCCR1 enables (TE = 1) and disables (TE = 0) the transmitter.

Shifter output is connected to the TXD pin while the transmitter is operating (TE = 1, or TE = 0 and transmission in progress). Wired-OR operation should be specified when more than one transmitter is used on the same SCI bus. The wired-OR mode select bit (WOMS) in SCCR1 determines whether TXD is an open-drain (wired-OR) output or a normal CMOS output. An external pull-up resistor on the TXD pin is necessary for wired-OR operation. WOMS controls TXD function whether the pin is used for SCI transmissions (TE = 1) or as a general-purpose I/O pin.

Data to be transmitted is written to TDR, then transferred to the serial shifter. The transmit data register empty (TDRE) flag in SCSR shows the status of TDR. When TDRE = 0, TDR contains data that has not been transferred to the shifter. Writing to

TDR again overwrites the data. TDRE is set when the data in TDR is transferred to the shifter. Before new data can be written to TDR, however, the processor must clear TDRE by writing to SCSR. If new data is written to TDR without first clearing TDRE, the data will not be transmitted.

The transmission complete (TC) flag in SCSR shows transmitter shifter state. When TC = 0, the shifter is busy. TC is set when all shifting operations are completed. TC is not automatically cleared. The processor must clear it by first reading SCSR while TC is set, then writing new data to TDR.

The state of the serial shifter is checked when the TE bit is set. If TC = 1, an idle frame is transmitted as a preamble to the following data frame. If TC = 0, the current operation continues until the final bit in the frame is sent, then the preamble is transmitted. The TC bit is set at the end of preamble transmission.

The send break (SBK) bit in SCCR1 is used to insert break frames in a transmission. A nonzero integer number of break frames is transmitted while SBK is set. Break transmission begins when SBK is set, and ends with the transmission in progress at the time either SBK or TE are cleared. If SBK is set while a transmission is in progress, that transmission finishes normally before the break begins. To assure the minimum break time, toggle SBK quickly to one and back to zero. The TC bit is set at the end of break transmission. After break transmission, at least one bit-time of logic level one (mark idle) is transmitted to ensure that a subsequent start bit can be detected.

If TE remains set, after all pending idle, data and break frames are shifted out, TDRE and TC are set and TXD is held at logic level one (mark).

When TE is cleared, the transmitter is disabled after all pending idle, data and break frames are transmitted. The TC flag is set, and the TXD pin reverts to control by PQSPAR and DDRQS. Buffered data is not transmitted after TE is cleared. To avoid losing data in the buffer, do not clear TE until TDRE is set.

Some serial communication systems require a mark on the TXD pin even when the transmitter is disabled. Configure the TXD pin as an output (DDRQS), then write a one to PORTQS bit 7. When the transmitter releases control of the TXD pin, it reverts to driving a logic one output.

To insert a delimiter between two messages, to place nonlistening receivers in wakeup mode between transmissions, or to signal a retransmission by forcing an idle line, clear and then set TE before data in the serial shifter has shifted out. The transmitter finishes the transmission, then sends a preamble. After the preamble is transmitted, if TDRE is set, the transmitter will mark idle. Otherwise, normal transmission of the next sequence will begin.

Both TDRE and TC have associated interrupts. The interrupts are enabled by the transmit interrupt enable (TIE) and transmission complete interrupt enable (TCIE) bits in SCCR1. Service routines can load the last byte of data in a sequence into the TDR, then terminate the transmission when a TDRE interrupt occurs.

6.4.3.6 Receiver Operation

The receiver enable (RE) bit in SCCR1 enables (RE = 1) and disables (RE = 0) the transmitter. The receiver contains a receive serial shifter and a parallel receive data register (RDR) located in the SCI data register (SCDR). The serial shifter cannot be directly accessed by the CPU. The receiver is double-buffered, allowing data to be held in RDR while other data is shifted in.

Receiver bit processor logic drives a state machine that determines the logic level for each bit-time. This state machine controls when the bit processor logic is to sample the RXD pin and also controls when data is to be passed to the receive serial shifter. A receive time (RT) clock is used to control sampling and synchronization. Data is shifted into the receive serial shifter according to the most recent synchronization of the RT clock with the incoming data stream. From this point on, data movement is synchronized with the MCU system clock. Operation of the receiver state machine is detailed in the *QSM Reference Manual (QSMRM/AD)*.

The number of bits shifted in by the receiver depends on the serial format. However, all frames must end with at least one stop bit. When the stop bit is received, the frame is considered to be complete, and the received data in the serial shifter is transferred to the RDR. The receiver data register flag (RDRF) is set when the data is transferred.

Noise errors, parity errors, and framing errors can be detected while a data stream is being received. Although error conditions are detected as bits are received, the noise flag (NF), the parity flag (PF), and the framing error (FE) flag in SCSR are not set until data is transferred from the serial shifter to RDR.

RDRF must be cleared before the next transfer from the shifter can take place. If RDRF is set when the shifter is full, transfers are inhibited and the overrun error (OR) flag in the SCSR is set. OR indicates that the CPU needs to service RDR faster. When OR is set, the data in RDR is preserved, but the data in the serial shifter is lost. Because framing, noise, and parity errors are detected while data is in the serial shifter, FE, NF, and PF cannot occur at the same time as OR.

When the CPU reads the SCSR and the SCDR in sequence, it acquires status and data, and also clears the status flags. Reading the SCSR acquires status and arms the clearing mechanism. Reading the SCDR acquires data and clears the SCSR.

When RIE in SCCR1 is set, an interrupt request is generated whenever RDRF is set. Because receiver status flags are set at the same time as RDRF, they do not have separate interrupt enables.

6.4.3.7 Idle-Line Detection

During a typical serial transmission, frames are transmitted isochronously and no idle time occurs between frames. Even when all the data bits in a frame are logic ones, the start bit provides one logic zero bit-time during the frame. An idle line is a sequence of contiguous ones equal to the current frame size. Frame size is determined by the state of the M bit in SCCR1.

The SCI receiver has both short and long idle-line detection capability. Idle-line detection is always enabled. The idle line type (ILT) bit in SCCR1 determines which type of detection is used. When an idle line condition is detected, the IDLE flag in SCSR is set.

For short idle-line detection, the receiver bit processor counts contiguous logic one bit-times whenever they occur. Short detection provides the earliest possible recognition of an idle line condition, because the stop bit and contiguous logic ones before and after it are counted. For long idle-line detection, the receiver counts logic ones after the stop bit is received. Only a complete idle frame causes the IDLE flag to be set.

In some applications, CPU overhead can cause a bit-time of logic level one to occur between frames. This bit-time does not affect content, but if it occurs after a frame of ones when short detection is enabled, the receiver flags an idle line.

When the idle line interrupt enable (ILIE) bit in SCCR1 is set, an interrupt request is generated when the IDLE flag is set. The flag is cleared by reading SCSR and SCDR in sequence. IDLE is not set again until after at least one frame has been received (RDRF = 1). This prevents an extended idle interval from causing more than one interrupt.

6.4.3.8 Receiver Wakeup

The receiver wakeup function allows a transmitting device to direct a transmission to a single receiver or to a group of receivers by sending an address frame at the start of a message. Hardware activates each receiver in a system under certain conditions. Resident software must process address information and enable or disable receiver operation.

A receiver is placed in wakeup mode by setting the receiver wakeup (RWU) bit in SCCR1. While RWU is set, receiver status flags and interrupts are disabled. Although the CPU can clear RWU, it is normally cleared by hardware during wakeup.

The WAKE bit in SCCR1 determines which type of wakeup is used. When WAKE = 0, idle-line wakeup is selected. When WAKE = 1, address-mark wakeup is selected. Both types require a software-based device addressing and recognition scheme.

Idle-line wakeup allows a receiver to sleep until an idle line is detected. When an idle-line is detected, the receiver clears RWU and wakes up. The receiver waits for the first frame of the next transmission. The byte is received normally, transferred to register RDR, and the RDRF flag is set. If software does not recognize the address, it can set RWU and put the receiver back to sleep. For idle-line wakeup to work, there must be a minimum of one frame of idle line between transmissions. There must be no idle time between frames within a transmission.

Address-mark wakeup uses a special frame format to wake up the receiver. When the MSB of an address-mark frame is set, that frame contains address information. The first frame of each transmission must be an address frame. When the MSB of a frame is set, the receiver clears RWU and wakes up. The byte is received normally, transferred to register RDR, and the RDRF flag is set. If software does not recognize the address, it can set RWU and put the receiver back to sleep. Address-mark wakeup al-

lows idle time between frames and eliminates idle time between transmissions. However, there is a loss of efficiency because of an additional bit-time per frame.

6.4.3.9 Internal Loop

The LOOPS bit in SCCR1 controls a feedback path on the data serial shifter. When LOOPS is set, SCI transmitter output is fed back into the receive serial shifter. TXD is asserted (idle line). Both transmitter and receiver must be enabled before entering loop mode.

6.5 QSM Initialization

After reset, the QSM remains in an idle state until initialized. A general sequence guide for initialization follows.

A. Global

1. Configuration register (QSMCR)
 - a. Write an interrupt arbitration priority value into the IARB field.
 - b. Clear the FREEZE and/or STOP bits for normal operation.
2. Interrupt vector and interrupt level registers (QIVR and QILR)
 - a. Write QSPI/SCI interrupt vector into QIVR.
 - b. Write QSPI (ILSPI) and SCI (ILSCI) interrupt priorities into QILR.
3. Port data and data direction registers (PORTQS and DDRQS)
 - a. Write a data word to PORTQS.
 - b. Establish direction of QSM pins used for I/O by writing to DDRQS.
4. Assign pin functions by writing to the pin assignment register (PQSPAR)

B. Queued Serial Peripheral Interface

1. Write appropriate values to QSPI command RAM.
2. QSPI control register zero (SPCR0)
 - a. Write a transfer rate value into the BR field.
 - b. Determine clock phase (CPHA), and clock polarity (CPOL).
 - c. Determine number of bits to be transferred in a serial operation (BIT).
 - d. Select master or slave operating mode (MSTR).
 - e. Enable or disable wired-OR operation (WOMQ).
3. QSPI control register one (SPCR1)
 - a. Establish a delay following serial transfer by writing to the DTL field.
 - b. Establish a delay before serial transfer by writing to the DSCKL field.
4. QSPI control register two (SPCR2)
 - a. Write an initial queue pointer value into the NEWQP field.
 - b. Write a final queue pointer value into the ENDQP field.
 - c. Enable or disable queue wraparound (WREN).
 - d. Write wraparound address into the WRTO field.
 - e. Enable or disable QSPI flag interrupt (SPIFIE).
5. QSPI control register three (SPCR3)
 - a. Enable or disable halt at end of queue (HALT).
 - b. Enable or disable halt and mode fault interrupts (HMIE).
 - c. Enable or disable loopback (LOOPQ).
6. To enable the QSPI, set the SPE bit in SPCR1.

- C. Serial Communication Interface (SCI)
 - 1. SCI control register zero (SCCR0)
 - a. Write a transfer rate (baud) value into the BR field.
 - 2. SCI control register one (SCCR1)
 - a. Select serial mode (M)
 - b. Enable use (PE) and type (PT) of parity check.
 - c. Select use (RWU) and type (WAKE) of receiver wakeup.
 - d. Enable idle-line detection (ILT) and interrupt (ILIE).
 - e. Enable or disable wired-OR operation (WOMS).
 - f. Enable or disable break transmission (BK).
 - 3. To receive
 - a. Set the receiver (RE) and receiver interrupt (RIE) bits in SCCR1.
 - 4. To transmit
 - a. Set transmitter (TE) and transmitter interrupt (TIE).
 - b. Clear the transmitter data register empty (TDRE) and transmit complete (TC) indicators by reading the serial communication interface status register (SCSR).
 - c. Write transmit data to the serial communication data register (SCDR).

SECTION 7 GENERAL-PURPOSE TIMER

This section is an overview of GPT function. Refer to the *GPT Reference Manual* (GP-TRM/AD) for complete information about the GPT module.

7.1 General

The 11-channel general-purpose timer (GPT) is used in systems where a moderate level of CPU control is required. The GPT consists of a capture/compare unit, a pulse accumulator, and two pulse-width modulators. A bus interface unit connects the GPT to the intermodule bus (IMB).

The capture/compare unit features three input capture channels, four output compare channels, and one channel that can be selected as an input capture or output compare channel. These channels share a 16-bit free-running counter which derives its clock from a nine-stage prescaler or from the external clock input signal, PCLK.

Pulse accumulator channel logic includes an 8-bit counter; the pulse accumulator can operate in either event counting mode or gated time accumulation mode.

Pulse-width modulator outputs are periodic waveforms whose duty cycles can be independently selected and modified by user software. The PWM circuits share a 16-bit free-running counter that can be clocked by the same nine-stage prescaler used by the capture/compare unit or by the PCLK input.

All GPT pins can also be used for general-purpose input/output. The input capture and output compare pins form a bidirectional 8-bit parallel port (PORTGPT). PWM pins are outputs only. PAI and PCLK pins are inputs only.

7

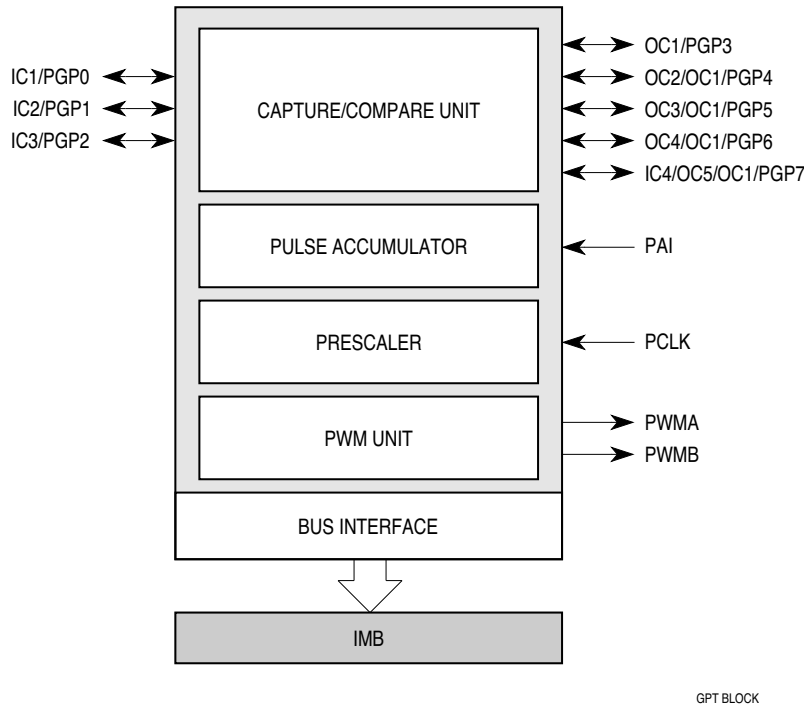

Figure 7-1 GPT Block Diagram

7.2 GPT Registers and Address Map

The GPT programming model consists of a configuration register (GPTMCR), parallel I/O registers (DDRGP, PORTGP), capture/compare registers (TCNT, TCTL1, TCTL2, TIC[1:3], TOC[1:4], TI4/O5, CFORC), pulse accumulator registers (PACNT, PACTL), pulse-width modulation registers (PWMA, PWMB, PWMC, PWMCNT, PWMBUFA, PWMBUFB), status registers (TFLG1, TFLG2) and interrupt control registers (TMSK1, TMSK2). Functions of the module configuration register are discussed in **7.3 Special Modes of Operation** and **7.4 Polled and Interrupt-Driven Operation**. Other register functions are discussed in the appropriate sections.

All registers can be accessed using byte or word operations. Certain capture/compare registers and pulse-width modulation registers must be accessed by word operations to ensure coherency. If byte accesses are used to read a register such as the timer counter register (TCNT), there is a possibility that data in the byte not being accessed will change while the other byte is read. Both bytes must be accessed at the same time.

The modmap (MM) bit in the system integration module configuration register (SIM-CR) defines the most significant bit (ADDR23) of the IMB address for each register in the MCU.

Refer to **APPENDIX D REGISTER SUMMARY** for a GPT address map and register bit/field descriptions. **SECTION 4 SYSTEM INTEGRATION MODULE** contains more information about how the state of MM affects the system.

7.3 Special Modes of Operation

The GPT module configuration register (GPTMCR) module configuration register (GPTMCR) is used to control special GPT operating modes. These include low-power stop mode, freeze mode, single-step mode, and test mode. Normal GPT operation can be polled or interrupt-driven. Refer to **7.4 Polled and Interrupt-Driven Operation** for more information.

7.3.1 Low-Power Stop Mode

Low-power stop operation is initiated by setting the STOP bit in GPTMCR. In stop mode the system clock to the module is turned off. The clock remains off until STOP is negated or a reset occurs. All counters and prescalers within the timer stop counting while the STOP bit is set. Only the module configuration register (GPTMCR) and the interrupt configuration register (ICR) should be accessed while in the stop mode. Accesses to other GPT registers cause unpredictable behavior. Low-power stop can also be used to disable module operation during debugging.

7.3.2 Freeze Mode

The freeze (FRZ[1:0]) bits in GPTMCR are used to determine what action is taken by the GPT when the IMB FREEZE signal is asserted. FREEZE is asserted when the CPU enters background debugging mode. At the present time, FRZ1 has no effect; setting FRZ0 causes the GPT to enter freeze mode. Refer to **SECTION 5 CENTRAL PROCESSING UNIT** for more information on background debugging mode.

Freeze mode freezes the current state of the timer. The prescaler and the pulse accumulator do not increment and changes to the pins are ignored (input pin synchronizers are not clocked). All of the other timer functions that are controlled by the CPU will operate normally; for example, registers can be written to change pin directions, force output compares, and read or write I/O pins.

While the FREEZE signal is asserted, the CPU has write access to registers and bits that are normally read-only, or write-once. The write-once bits can be written to as often as needed. The prescaler and the pulse accumulator remain stopped and the input pins are ignored until the FREEZE signal is negated (the CPU is no longer in BDM), the FRZ0 bit is cleared, or the MCU is reset.

Activities that are in progress prior to FREEZE assertion are completed. For example, if an input edge on an input capture pin is detected just as the FREEZE signal is asserted, the capture occurs and the corresponding interrupt flag is set.

7.3.3 Single-Step Mode

Two bits in GPTMCR support GPT debugging without using BDM. When the STOPP bit is asserted, the prescaler and the pulse accumulator stop counting and changes at input pins are ignored. Reads of the GPT pins return the state of the pin when STOPP was set. After STOPP is set, the INCP bit can be set to increment the prescaler and clock the input synchronizers once. The INCP bit is self-negating after the prescaler is incremented. INCP can be set repeatedly. The INCP bit has no effect when the STOPP bit is not set.

7.3.4 Test Mode

Test mode is used during Freescale factory testing. The GPT has no dedicated test-mode control register; all GPT testing is done under control of the system integration module.

7.4 Polled and Interrupt-Driven Operation

Normal GPT function can be polled or interrupt-driven. All GPT functions have an associated status flag and an associated interrupt. The timer interrupt flag registers (TFLG1 and TFLG2) contain status flags used for polled and interrupt-driven operation. The timer mask registers (TMSK1 and TMSK2) contain interrupt control bits. Control routines can monitor GPT operation by polling the status registers. When an event occurs, the control routine transfers control to a service routine that handles that event. If interrupts are enabled for an event, the GPT requests interrupt service when the event occurs. Using interrupts does not require continuously polling the status flags to see if an event has taken place. However, status flags must be cleared after an interrupt is serviced, in order to disable the interrupt request.

7.4.1 Polled Operation

When an event occurs in the GPT, that event sets a status flag in TFLG1 or TFLG2. The GPT sets the flags; they cannot be set by the CPU. TFLG1 and TFLG2 are 8-bit registers that can be accessed individually or as one 16-bit register. The registers are initialized to zero at reset. **Table 7-1** shows status flag assignment.

Table 7-1 GPT Status Flags

Flag Mnemonic	Register Assignment	Source
IC1F	TFLG1	Input Capture 1
IC2F	TFLG1	Input Capture 2
IC3F	TFLG1	Input Capture 3
OC1F	TFLG1	Output Compare 1
OC2F	TFLG1	Output Compare 2
OC3F	TFLG1	Output Compare 3
OC4F	TFLG1	Output Compare 4
I4/O5F	TFLG1	Input Capture 4/Output Compare 5
TOF	TFLG2	Timer Overflow
PAOVF	TFLG2	Pulse Accumulator Overflow
PAIF	TFLG2	Pulse Accumulator Input

For each bit in TFLG1 and TFLG2 there is a corresponding bit in TMSK1 and TMSK2 in the same bit position. If a mask bit is set and an associated event occurs, a hardware interrupt request is generated.

To re-enable a status flag after an event occurs, the status flags must be cleared. Status registers are cleared in a particular sequence. The register must first be read for set flags, then zeros must be written to the flags that are to be cleared. If a new event occurs between the time that the register is read and the time that it is written, the associated flag is not cleared.

7.4.2 GPT Interrupts

The GPT has 11 internal sources that can cause it to request interrupt service (refer to **Table 7-2**). Setting bits in TMSK1 and TMSK2 enables specific interrupt sources. TMSK1 and TMSK2 are 8-bit registers that can be addressed individually or as one 16-bit register. The registers are initialized to zero at reset. For each bit in TMSK1 and TMSK2 there is a corresponding bit in TFLG1 and TFLG2 in the same bit position. TMSK2 also controls the operation of the timer prescaler. Refer to **7.7 Prescaler** for more information.

The value of the interrupt level (IRL) field in the interrupt control register (ICR) determines the priority of GPT interrupt requests. IRL values correspond to MCU interrupt request signals $\overline{IRQ}[7:1]$. $\overline{IRQ}7$ is the highest priority interrupt request signal; $\overline{IRQ}1$ is the lowest-priority signal. A value of %111 causes $\overline{IRQ}7$ to be asserted when a GPT interrupt request is made; lower field values cause corresponding lower-priority interrupt request signals to be asserted. Setting field value to %000 disables interrupts.

Table 7-2 GPT Interrupt Sources

Name	Source Number	Source	Vector Number
—	0000	Adjusted Channel	IVBA : 0000
IC1	0001	Input Capture 1	IVBA : 0001
IC2	0010	Input Capture 2	IVBA : 0010
IC3	0011	Input Capture 3	IVBA : 0011
OC1	0100	Output Compare 1	IVBA : 0100
OC2	0101	Output Compare 2	IVBA : 0101
OC3	0110	Output Compare 3	IVBA : 0110
OC4	0111	Output Compare 4	IVBA : 0111
IC4/OC5	1000	Input Capture 4/Output Compare 5	IVBA : 1000
TO	1001	Timer Overflow	IVBA : 1001
PAOV	1010	Pulse Accumulator Overflow	IVBA : 1010
PAI	1011	Pulse Accumulator Input	IVBA : 1011

The CPU32 recognizes only interrupt request signals of a priority greater than the status register interrupt priority (IP) mask value. When the CPU acknowledges an interrupt request, the priority of the acknowledged request is written to the IP mask and driven out on the IMB address lines.

When the IP mask value driven out on the address lines is the same as the IRL value, the GPT contends for arbitration priority. GPT arbitration priority is determined by the value of the IARB field in GPTMCR. Each MCU module that can make interrupt requests must be assigned a nonzero IARB value in order to implement an arbitration scheme. Arbitration is performed by means of serial assertion of IARB field bit values.

When the GPT wins interrupt arbitration, it responds to the CPU interrupt acknowledge cycle by placing an interrupt vector number on the data bus. The vector number is used to calculate displacement into the CPU32 exception vector table. Vector numbers are formed by concatenating the value in the ICR IVBA field with a 4-bit value supplied by the GPT when an interrupt request is made. Hardware prevents the vector number from changing while it is being driven out on the IMB. Vector number assignment is shown in **Table 7-2**.

At reset, IVBA is initialized to \$0. To enable interrupt-driven timer operation, the upper nibble (\$4–\$F) of a user-defined vector number (\$40–\$FF) must be written to IVBA, and interrupt handler routines must be located at the addresses pointed to by the corresponding vector. Note that IVBA must be written before GPT interrupts are enabled, or the GPT could supply a vector number (\$00 to \$0F) that corresponds to an assigned or reserved exception vector.

The internal GPT interrupt priority hierarchy is shown in **Table 7-2**. The lower the interrupt source number, the higher the priority. A single GPT interrupt source can be given priority over all other GPT interrupt sources by assigning the priority adjust field (PAB) in the ICR a value equal to its source number.

Interrupt requests are asserted until associated status flags are cleared. Status flags must be cleared in a particular sequence. The status register must first be read for set flags, then zeros must be written to the flags that are to be cleared. If a new event occurs between the time that the register is read and the time that it is written, the associated flag is not cleared.

Refer to **SECTION 5 CENTRAL PROCESSING UNIT** and **SECTION 4 SYSTEM INTEGRATION MODULE** for more information about exceptions and interrupts.

7.5 Pin Descriptions

The GPT uses 12 pins. Each pin can perform more than one function. Descriptions of GPT pins divided into functional groups follow.

7.5.1 Input Capture Pins (IC[1:3])

Each of these pins is associated with a single GPT input capture function. Each pin has hysteresis. Any pulse longer than two system clocks is guaranteed to be valid and any pulse shorter than one system clock is ignored. Each pin has an associated 16-bit capture register that holds the captured counter value. These pins can also be used for general-purpose I/O. Refer to **7.8.2 Input Capture Functions** for more information.

7.5.2 Input Capture/Output Compare Pin (IC4/OC5)

This pin can be configured for use by either an input capture or an output compare function. It has an associated 16-bit register that is used for holding either the input capture value or the output match value. When used for input capture the pin has the same hysteresis as other input capture pins. The pin can be used for general-purpose I/O. Refer to **7.8.2 Input Capture Functions** and **7.8.3 Output Compare Functions** for more information.

7.5.3 Output Compare Pins (OC[1:4])

These pins are used for GPT output compare functions. Each pin has an associated 16-bit compare register and a 16-bit comparator. Pins OC2, OC3, and OC4 are associated with a specific output compare function. The OC1 function can affect the output of all compare pins. If the OC1 pin is not needed for an output compare function it can

be used to output the clock selected for the timer counter register. Any of these pins can also be used for general-purpose I/O. Refer to **7.8.3 Output Compare Functions** for more information.

7.5.4 Pulse Accumulator Input Pin (PAI)

The PAI pin connects a discrete signal to the pulse accumulator for timed or gated pulse accumulation. PAI has hysteresis. Any pulse longer than two system clocks is guaranteed to be valid and any pulse shorter than one system clock is ignored. It can be used as a general-purpose input pin. Refer to **7.10 Pulse Accumulator** for more information.

7.5.5 Pulse-Width Modulation (PWMA, PWMB)

PWMA and PWMB pins carry pulse-width modulator outputs. The modulators can be programmed to generate a periodic waveform of variable frequency and duty cycle. PWMA can be used to output the clock selected as the input to the PWM counter. These pins can also be used for general-purpose output. Refer to **7.11 Pulse-Width Modulation Unit** for more information.

7.5.6 Auxiliary Timer Clock Input (PCLK)

PCLK connects an external clock to the GPT. The external clock can be used as the clock source for the capture/compare unit or the PWM unit in place of one of the prescaler outputs. PCLK has hysteresis. Any pulse longer than two system clocks is guaranteed to be valid and any pulse shorter than one system clock is ignored. This pin can also be used as a general-purpose input pin. Refer to **7.7 Prescaler** for more information.

7.6 General-Purpose I/O

Any GPT pin can be used for general-purpose I/O when it is not used for another purpose. Capture/compare pins are bidirectional, others can be used only for output or input. I/O direction is controlled by a data direction bit in the port GP data direction register (DDRGP).

Parallel data is read from and written to the port GP data register (PORTGP). Pin data can be read even when pins are configured for a timer function. Data read from PORTGP always reflects the state of the external pin, while data written to PORTGP may not always affect the external pin.

Data written to PORTGP does not immediately affect pins used for output compare functions, but the data is latched. When an output compare function is disabled, the last data written to PORTGP is driven out on the associated pin if it is configured as an output. Data written to PORTGP can cause input captures if the corresponding pin is configured for input capture function.

The pulse accumulator input (PAI) and the external clock input (PCLK) pins provide general-purpose input. The state of these pins can be read by accessing the PAIS and PCLKS bits in the pulse accumulator control register (PACTL).

Pulse-width modulation A and B (PWMA/PWMB) output pins can serve as general-purpose outputs. The force PWM value (FPWMx) and the force logic one (F1x) bits in the compare force (CFORC) and PWM control (PWMC) registers, respectively, control their operation.

7.7 Prescaler

Capture/compare and PWM units have independent 16-bit free-running counters as a main timing component. These counters derive their clocks from the prescaler or from the PCLK input. **Figure 7-2** is a prescaler block diagram.

In the prescaler, the system clock is divided by a nine-stage divider chain. Prescaler outputs equal to system clock divided by 2, 4, 8, 16, 32, 64, 128, 256 and 512 are provided. Connected to these outputs are two multiplexers, one for the capture/compare unit, the other for the PWM unit.

Multiplexers can each select one of seven prescaler taps or an external input from the PCLK pin. Multiplexer output for the timer counter (TCNT) is selected by bits CPR[2:0] in timer interrupt mask register 2 (TMSK2). Multiplexer output for the PWM counter (PWMCNT) is selected by bits PPR[2:0] in PWM control register C (PWMC).

After reset, the GPT is configured to use system clock divided by four for TCNT and system clock divided by two for PWMCNT. Initialization software can change the division factor. The PPR bits can be written at any time but the CPR bits can only be written once after reset unless the GPT is in test or freeze mode.

The prescaler can be read at any time. In freeze mode the prescaler can also be written. Word accesses must be used to ensure coherency. If coherency is not needed byte accesses can be used. The prescaler value is contained in bits [8:0] while bits [15:9] are unimplemented and are read as zeros.

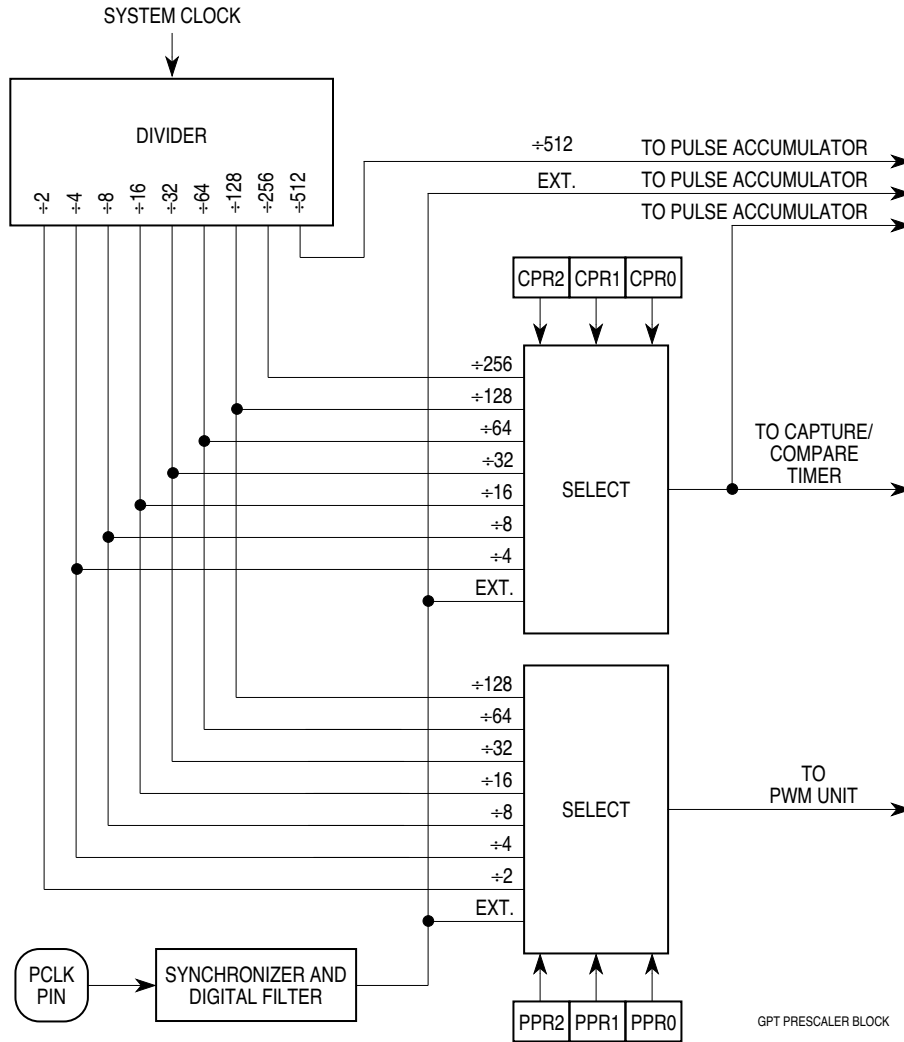

7

Figure 7-2 Prescaler Block Diagram

Multiplexer outputs (including the PCLK signal) can be connected to external pins) can be connected to external pins. The CPROUT bit in the TMSK2 register configures the OC1 pin to output the TCNT clock and the PPROUT bit in the PWMC register configures the PWMA pin to output the PWMC clock. CPROUT and PPROUT can be written at any time. Clock signals on OC1 and PWMA do not have a 50% duty cycle. They have the period of the selected clock but are high for only one system clock time.

The prescaler also supplies three clock signals to the pulse accumulator clock select mux. These are the system clock divided by 512, the external clock signal from the PCLK pin and the capture/compare clock signal.

7.8 Capture/Compare Unit

The capture/compare unit contains the timer counter (TCNT), the input capture (IC) functions and the output compare (OC) functions. **Figure 7-3** is a block diagram of the capture/compare unit.

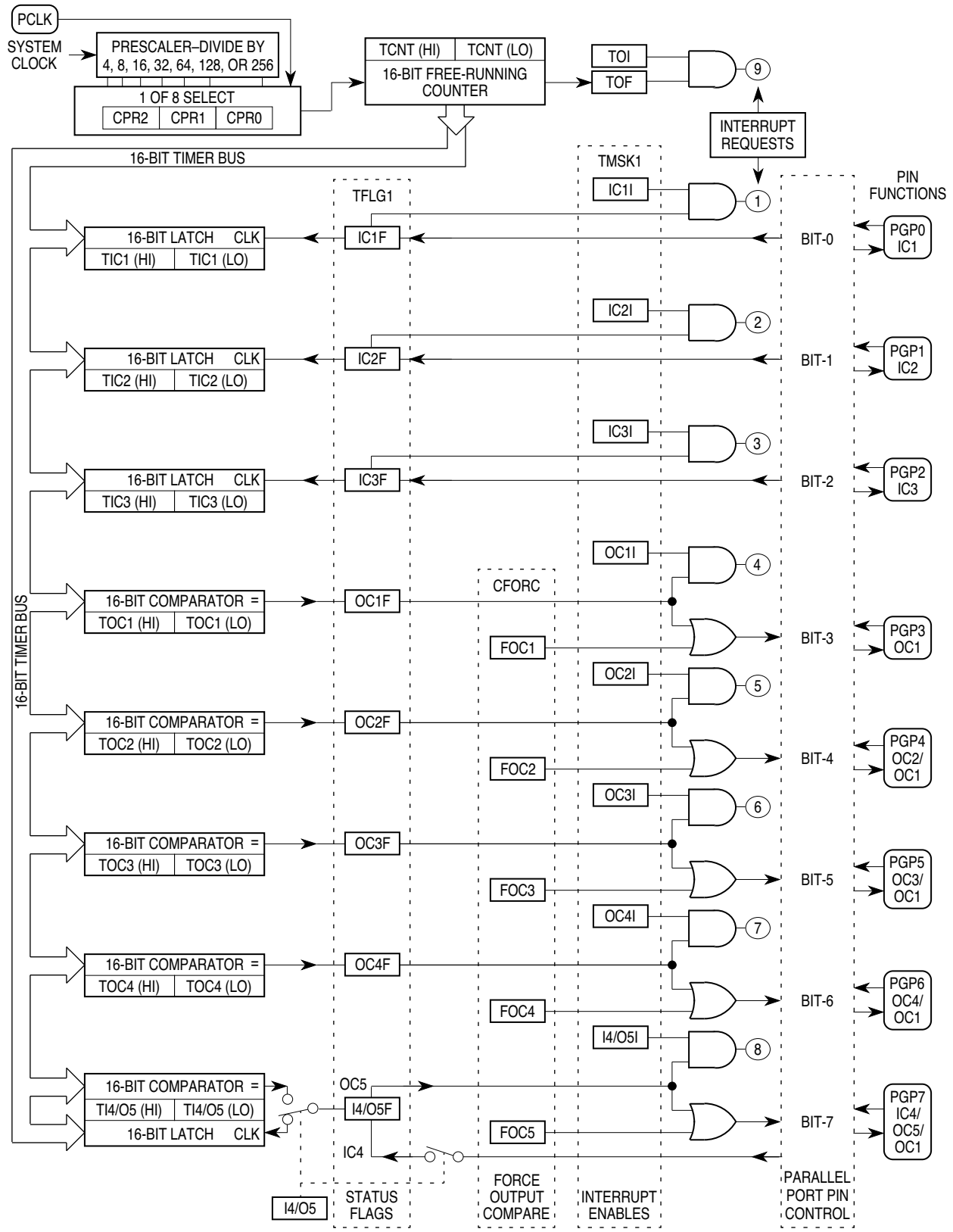

16/32 CC BLOCK

Figure 7-3 Capture/Compare Unit Block Diagram

7.8.1 Timer Counter

The timer counter (TCNT) is the key timing component in the capture/compare unit. The timer counter is a 16-bit free-running counter that starts counting after the processor comes out of reset. The counter cannot be stopped during normal operation. After reset, the GPT is configured to use the system clock divided by four as the input to the counter. The prescaler divides the system clock and provides selectable input frequencies. User software can configure the system to use one of seven prescaler outputs or an external clock.

The counter can be read any time without affecting its value. Because the GPT is interfaced to the IMB and the IMB supports a 16-bit bus, a word read gives a coherent value. If coherency is not needed, byte accesses can be made. The counter is set to \$0000 during reset and is normally a read-only register. In test mode and freeze mode, any value can be written to the timer counter.

When the counter rolls over from \$FFFF to \$0000, the timer overflow flag (TOF) in timer interrupt flag register 2 (TFLG2) is set. An interrupt can be enabled by setting the corresponding interrupt enable bit (TOI) in timer interrupt mask register 2 (TMSK2). Refer to **7.4.2 GPT Interrupts** for more information.

7.8.2 Input Capture Functions

All GPT input capture functions use the same 16-bit timer counter (TCNT). Each input capture pin has a dedicated 16-bit latch and input edge-detection/selection logic. Each input capture function has an associated status flag, and can cause the GPT to make an interrupt service request.

When a selected edge transition occurs on an input capture pin, the associated 16-bit latch captures the content of TCNT and sets the appropriate status flag. An interrupt request can be generated when the transition is detected.

Edge-detection logic consists of control bits that enable edge detection and select a transition to detect. The EDGxA and EDGxB bits in timer control register 2 (TCTL2) determine whether the input capture functions detect rising edges only, falling edges only, or both rising and falling edges. Clearing both bits disables the input capture function. Input capture functions operate independently of each other and can capture the same TCNT value if individual input edges are detected within the same timer count cycle.

Input capture interrupt logic includes a status flag, which indicates that an edge has been detected, and an interrupt enable bit. An input capture event sets the ICxF bit in the timer interrupt flag register 1 (TFLG1) and causes the GPT to make an interrupt request if the corresponding ICxI bit is set in the timer interrupt mask register 1 (TMSK1). If the ICxI bit cleared, software must poll the status flag to determine that an event has occurred. Refer to **7.4 Polled and Interrupt-Driven Operation** for more information.

Input capture events are generally asynchronous to the timer counter. Because of this, input capture signals are conditioned by a synchronizer and digital filter. Events are

synchronized with the system clock so that latching of TCNT content and counter incrementation occur on opposite half-cycles of the system clock. Inputs have hysteresis. Capture of any transition longer than two system clocks is guaranteed; any transition shorter than one system clock has no effect.

Figure 7-4 shows the relationship of system clock to synchronizer output. The value latched into the capture register is the value of the counter several system clock cycles after the transition that triggers the edge detection logic. There can be up to one clock cycle of uncertainty in latching of the input transition. Maximum time is determined by the system clock frequency.

The input capture register is a 16-bit register. A word access is required to ensure coherency. If coherency is not required, byte accesses can be used to read the register. Input capture registers can be read at any time without affecting their values.

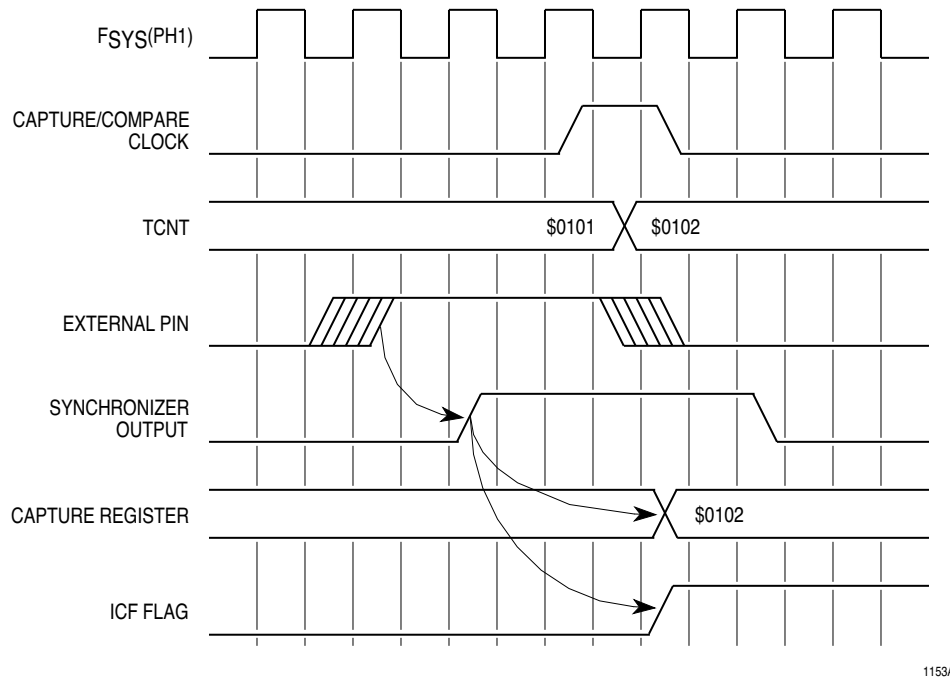

1153A

Figure 7-4 Input Capture Timing Example

An input capture occurs every time a selected edge is detected, even when the input capture status flag is set. This means that the value read from the input capture register corresponds to the most recent edge detected, which may not be the edge that caused the status flag to be set.

7.8.3 Output Compare Functions

Each GPT output compare pin has an associated 16-bit compare register and a 16-bit comparator. Each output compare function has an associated status flag, and can cause the GPT to make an interrupt service request. Output compare logic is designed to prevent false compares during data transition times.

When the programmed content of an output compare register matches the value in TCNT, an output compare status flag (OCxF) bit in TFLG1 is set. If the appropriate interrupt enable bit (OCxI) in TMSK1 is set, an interrupt request is made when a match occurs. Refer to **7.4.2 GPT Interrupts** for more information.

Operation of output compare 1 differs from that of the other output compare functions. OC1 control logic can be programmed to make state changes on other OC pins when an OC1 match occurs. Control bits in the timer compare force register (CFORC) allow for early forced compares.

7.8.3.1 Output Compare 1

Output compare 1 can affect any or all of OC[1:5] when an output match occurs. In addition to allowing generation of multiple control signals from a single comparison operation, this function makes it possible for two or more output compare functions to control the state of a single OC pin. Output pulses as short as one timer count can be generated in this way.

The OC1 action mask register (OC1M) and the OC1 action data register (OC1D) control OC1 function. Setting a bit in OC1M selects a corresponding bit in the GPT parallel data port. Bits in OC1D determine whether selected bits are to be set or cleared when an OC1 match occurs. Pins must be configured as outputs in order for the data in the register to be driven out on the corresponding pin. If an OC1 match and another output match occur at the same time and both attempt to alter the same pin, the OC1 function controls the state of the pin.

7.8.3.2 Forced Output Compare

Timer compare force register (CFORC) is used to make forced compares. The action taken as a result of a forced compare is the same as when an output compare match occurs, except that status flags are not set. Forced channels take programmed actions immediately after the write to CFORC.

The CFORC register is implemented as the upper byte of a 16-bit register which also contains the PWM control register C (PWMC). It can be accessed as eight bits or a word access can be used. Reads of force compare bits (FOC) have no meaning and always return zeros. These bits are self-negating.

7.9 Input Capture 4/Output Compare 5

The IC4/OC5 pin can be used for input capture, output compare, or general-purpose I/O. A function enable bit (I4/O5) in the pulse accumulator control register (PACTL) configures the pin for input capture (IC4) or output compare function (OC5). Both bits are cleared during reset, configuring the pin as an input, but also enabling the OC5 function. IC4/OC5 I/O functions are controlled by the I4/O5 bit in the port GP data direction register (DDRGP).

The 16-bit register (TI4/O5) used with the IC4/OC5 function acts as an input capture register or as an output compare register depending on which function is selected. When used as the input capture 4 register, it cannot be written except in test or freeze mode.

7.10 Pulse Accumulator

The pulse accumulator counter (PACNT) is an 8-bit read/write up-counter. PACNT can operate in external event counting or gated time accumulation modes. **Figure 7-5** is a block diagram of the pulse accumulator.

In event counting mode, the counter increments each time a selected transition of the pulse accumulator input (PAI) pin is detected. The maximum clocking rate is the system clock divided by four.

In gated time accumulation mode a clock increments PACNT while the PAI pin is in the active state. There are four possible clock sources.

Two bits in the TFLG2 register show pulse accumulator status. The pulse accumulator flag (PAIF) indicates that a selected edge has been detected at the PAI pin. The pulse accumulator overflow flag (PAOVF) indicates that the pulse accumulator count has rolled over from \$FF to \$00. This can be used to extend the range of the counter beyond eight bits.

An interrupt request can be made when each of the status flags is set. However, operation of the PAI interrupt depends on operating mode. In event counting mode, an interrupt is requested when the edge being counted is detected. In gated mode, the request is made when the PAI input changes from active to inactive state. Interrupt requests are enabled by the PAOVI and PAII bits in the TMSK2 register.

Bits in the pulse accumulator control register (PACTL) control the operation of PACNT. The PAMOD bit selects event counting or gated operation. In event counting mode, the PEDGE control bit determines whether a rising or falling edge is detected; in gated mode, PEDGE specifies the active state of the gate signal. Bits PACLK[1:0] select the clock source used in gated mode.

PACTL and PACNT are implemented as one 16-bit register, but can be accessed with byte or word access cycles. Both registers are cleared at reset, but the PAIS and PCLKS bits show the state of the PAI and PCLK pins.

The PAI pin can also be used for general-purpose input. The logic state of the PAIS bit in PACTL shows the state of the pin.

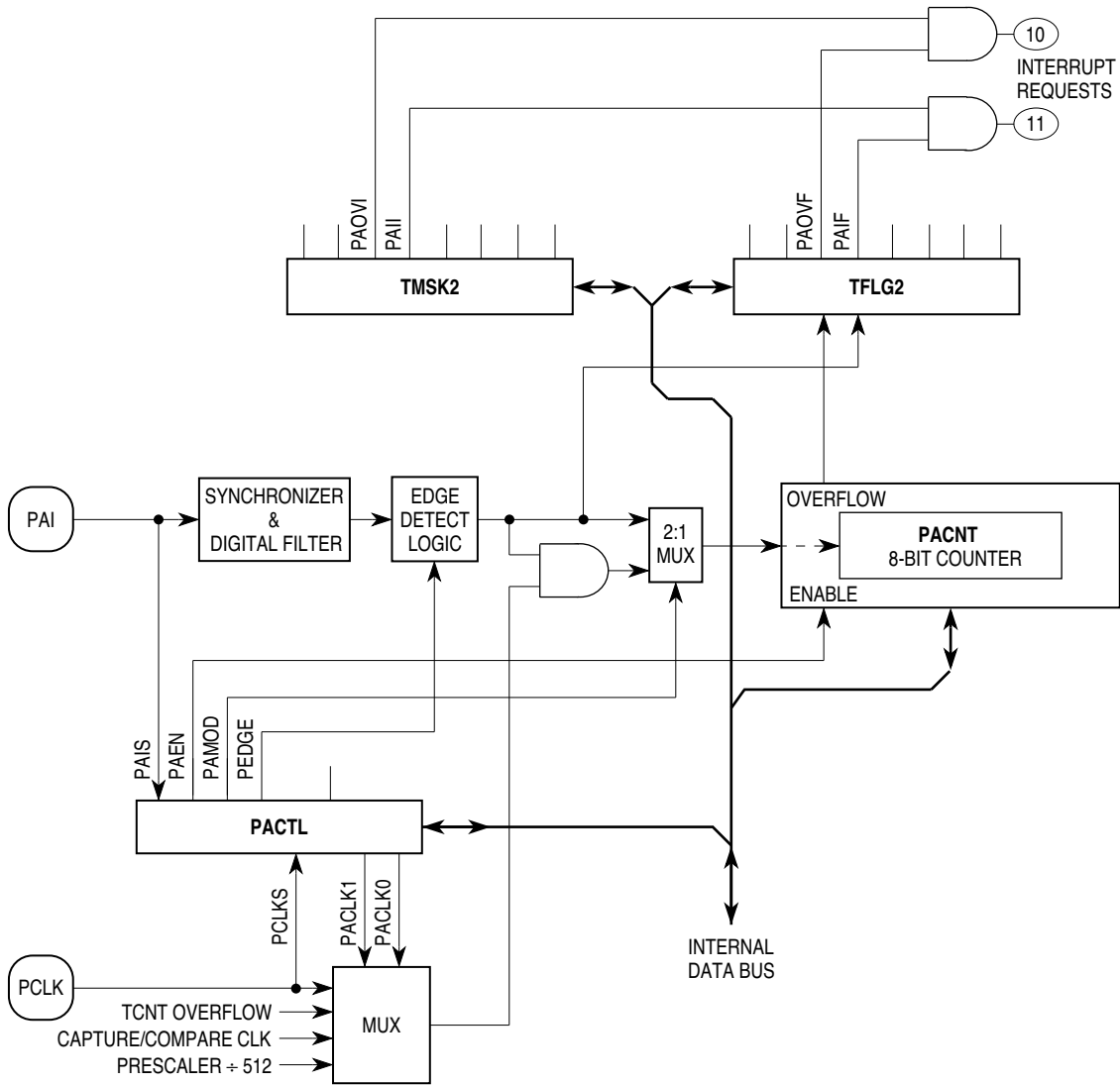

7

Figure 7-5 Pulse Accumulator Block Diagram

7.11 Pulse-Width Modulation Unit

The pulse-width modulation (PWM) unit has two output channels, PWMA and PWMB. A single clock output from the prescaler multiplexer drives a 16-bit counter that is used to control both channels. **Figure 7-6** is a block diagram of the pulse-width modulation unit.

The PWM unit has two operational modes. Fast mode uses a clocking rate equal to 1/256 of the prescaler output rate; slow mode uses a rate equal to 1/32768 of the prescaler output rate. The duty cycle ratios of the two PWM channels can be individually controlled by software. The PWMA pin can also output the clock that drives the PWM counter. PWM pins can also be used as output pins.

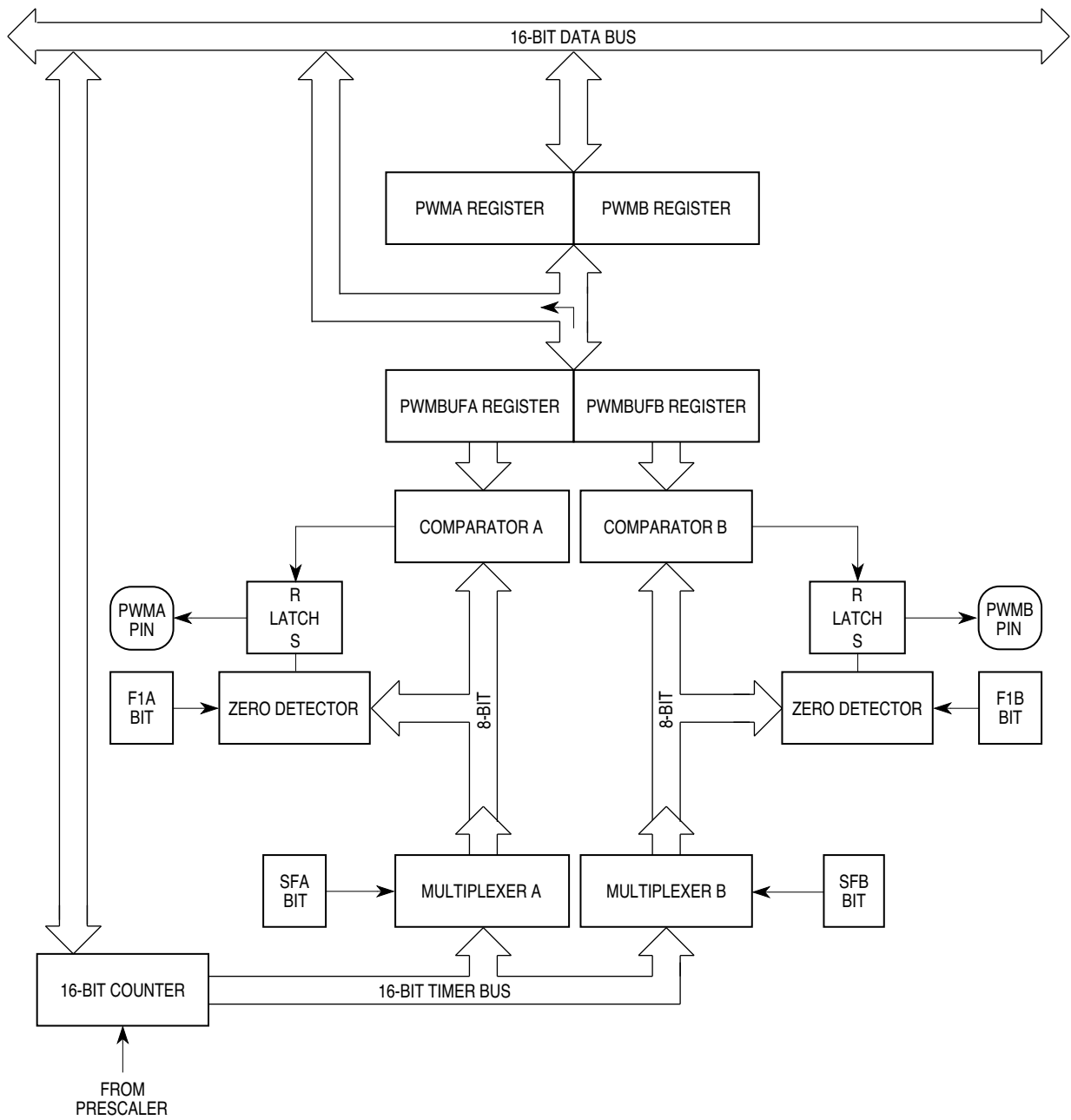

16/32 PWM BLOCK

Figure 7-6 PWM Block Diagram

7.11.1 PWM Counter

The 16-bit counter in the PWM unit is similar to the timer counter in the capture/compare unit. During reset, the GPT is configured to use the system clock divided by two to drive the counter. Initialization software can reconfigure the counter to use one of seven prescaler outputs or an external clock input from the PCLK pin.

The PWM count register (PWMCNT) can be read at any time without affecting its value. A read must be a word access to ensure coherence, but byte accesses can be made if coherence is not needed. The counter is cleared to \$0000 during reset and is a read-only register except in freeze or test mode.

Fifteen of the sixteen counter bits are output to multiplexers A and B. The multiplexers provide the fast and slow modes of the PWM unit. Mode for PWMA is selected by the SFA bit in the PWM control register C (PWMC). Mode for PWMB is selected by the SFB bit in the same register.

PWMA, PWMB, and PPR[2:0] bits in PWMC control PWM output frequency. In fast mode, bits [7:0] of PWMCNT are used to clock the PWM logic; in slow mode, bits [14:7] are used. The period of a PWM output in is 128 times longer than the fast mode period. **Table 7-3** shows a range of PWM output frequencies using a 16.78-MHz system clock and 20.97-MHz system clock.

**Table 7-3 PWM Frequency Ranges
Using 16.78-MHz/20.97-MHz System Clocks**

PPR [2:0]	Prescaler Tap		SFA/B = 0		SFA/B = 1	
	16.78 MHz	20.97 MHz	16.78 MHz	20.97 MHz	16.78 MHz	20.97 MHz
000	Div 2 = 8.39 MHz	Div 2 = 10.5 MHz	32.8 kHz	41 kHz	256 Hz	320 Hz
001	Div 4 = 4.19 MHz	Div 4 = 5.25 MHz	16.4 kHz	20.5 kHz	128 Hz	160 Hz
010	Div 8 = 2.10 MHz	Div 8 = 2.62 MHz	8.19 kHz	10.2 kHz	64.0 Hz	80.0 Hz
011	Div 16 = 1.05 MHz	Div 16 = 1.31 MHz	4.09 kHz	5.15 kHz	32.0 Hz	40.0 Hz
100	Div 32 = 524 kHz	Div 32 = 655 kHz	2.05 kHz	2.56 kHz	16.0 Hz	20.0 Hz
101	Div 64 = 262 kHz	Div 64 = 328 kHz	1.02 kHz	1.28 kHz	8.0 Hz	10.0 Hz
110	Div 128 = 131 kHz	Div 128 = 164 kHz	512 Hz	641 Hz	4.0 Hz	5.0 Hz
111	PCLK	PCLK	PCLK/256	PCLK/256	PCLK/32768	PCLK/32768

7.11.2 PWM Function

The pulse width values of the PWM outputs are determined by control registers PWMA and PWMB. PWMA and PWMB are 8-bit registers implemented as two bytes of a 16-bit register. PWMA and PWMB can be accessed as separate bytes or as one 16-bit register. A value of \$00 loaded into either register causes the corresponding output pin to output a continuous logic level zero signal. A value of \$80 causes the corresponding output signal to have a 50% duty cycle, and so on, to the maximum value of \$FF, which corresponds to an output which is at logic level one for 255/256 of the cycle.

Setting the F1A (for PWMA) or F1B (for PWMB) bits in the register causes the corresponding pin to output a continuous logic level one signal. The logic level of the associated pin does not change until the end of the current cycle. F1A and F1B are the lower two bits of CFORC, but can be accessed at the same word address as PWMC.

Data written to PWMA and PWMB is not used until the end of a complete cycle. This prevents spurious short or long pulses when register values are changed. The current duty cycle value is stored in the appropriate PWM buffer register (PWMBUFA or PWMBUFB). The new value is transferred from the PWM register to the buffer register at the end of the current cycle.

Registers PWMA, PWMB, and PWMC are reset to \$00 during reset. These registers may be written or read at any time. PWMC is implemented as the lower byte of a 16-bit register. The upper byte is the CFORC register. The buffer registers, PWMBUFA and PWMBUFB, are read-only at all times and may be accessed as separate bytes or as one 16-bit register.

Pins PWMA and PWMB can also be used for general-purpose output. The values of the F1A and F1B bits in PWMC are driven out on the corresponding PWM pins when normal PWM operation is disabled. When read, the F1A and F1B bits reflect the states of the PWMA and PWMB pins.

APPENDIX A ELECTRICAL CHARACTERISTICS

This appendix contains electrical specification tables and reference timing diagrams.

Table A-1 Maximum Ratings

Num	Rating	Symbol	Value	Unit
1	Supply Voltage ^{1,2,7}	V_{DD}	-0.3 to +6.5	V
2	Input Voltage ^{1,2,3,5,7}	V_{in}	-0.3 to +6.5	V
3	Instantaneous Maximum Current Single pin limit (applies to all pins) ^{1,5,6,7}	I_D	25	mA
4	Operating Maximum Current Digital Input Disruptive Current ^{4,5,6,7,8} $V_{NEGCLMAP} \equiv -0.3$ V $V_{POSCLAMP} \equiv V_{DD} + 0.3$	I_{ID}	-500 to 500	μ A
5	Operating Temperature Range MC68331 No Suffix MC68331 "C" Suffix MC68331 "V" Suffix MC68331 "M" Suffix	T_A	T_L to T_H 0 to 70 -40 to 85 -40 to 105 -40 to 125	$^{\circ}$ C
6	Storage Temperature Range	T_{stg}	-55 to 150	$^{\circ}$ C

1. Permanent damage can occur if maximum ratings are exceeded. Exposure to voltages or currents in excess of recommended values affects device reliability. Device modules may not operate normally while being exposed to electrical extremes.
2. Although sections of the device contain circuitry to protect against damage from high static voltages or electrical fields, take normal precautions to avoid exposure to voltages higher than maximum-rated voltages.
3. All pins except T_{STME}/TSC
4. All functional non-supply pins are internally clamped to V_{SS} . All functional pins except EX-TAL and XFC are internally clamped to V_{DD} .
5. Input must be current limited to the value specified. To determine the value of the required current-limiting resistor, calculate resistance values for positive and negative clamp voltages, then use the larger of the two values.
6. Power supply must maintain regulation within operating V_{DD} range during instantaneous and operating maximum current conditions.
7. This parameter is periodically sampled rather than 100% tested.
8. Total input current for all digital input-only and all digital input/output pins must not exceed 10 mA. Exceeding this limit can cause disruption of normal operation.

A

Table A-2 Typical Ratings, 16.78 MHz Operation

Num	Rating	Symbol	Value	Unit
1	Supply Voltage	V_{DD}	5.0	V
2	Operating Temperature	T_A	25	°C
3	V_{DD} Supply Current RUN LPSTOP, VCO off LPSTOP, External clock, maxi f_{sys}	I_{DD}	75 125 3	mA μ A mA
4	Clock Synthesizer Operating Voltage	V_{DDSYN}	5.0	V
5	V_{DDSYN} Supply Current VCO on, maximum f_{sys} External Clock, maximum f_{sys} LPSTOP, VCO off V_{DD} powered down	I_{DDSYN}	1.0 4.0 100 50	mA mA μ A μ A
6	Power Dissipation	P_D	455	mW

Table A-2a Typical Ratings, 20.97 MHz Operation

Num	Rating	Symbol	Value	Unit
1	Supply Voltage	V_{DD}	5.0	V
2	Operating Temperature	T_A	25	°C
3	V_{DD} Supply Current RUN LPSTOP, VCO off LPSTOP, External clock, maxi f_{sys}	I_{DD}	113 125 3.75	mA μ A μ A
4	Clock Synthesizer Operating Voltage	V_{DDSYN}	5.0	V
5	V_{DDSYN} Supply Current VCO on, maximum f_{sys} External Clock, maximum f_{sys} LPSTOP, VCO off V_{DD} powered down	I_{DDSYN}	1.0 5.0 100 50	mA mA μ A μ A
6	Power Dissipation	P_D	570	mW

Table A-3 Thermal Characteristics

Num	Rating	Symbol	Value	Unit
1	Thermal Resistance	$\Theta_{\theta A}$		°C/W
	Plastic 132-Pin Surface Mount		38	
	Plastic 144-Pin Surface Mount		46	
	Thin Plastic 144-Pin Surface Mount		49	

NOTES:

The average chip-junction temperature (T_J) in C can be obtained from:

$$T_J = T_A + (P_D \times \Theta_{\theta A}) \tag{1}$$

where

- T_A = Ambient Temperature, °C
- $\Theta_{\theta A}$ = Package Thermal Resistance, Junction-to-Ambient, °C/W
- P_D = $P_{INT} + P_{I/O}$
- P_{INT} = $I_{DD} \times V_{DD}$, Watts — Chip Internal Power
- $P_{I/O}$ = Power Dissipation on Input and Output Pins — User Determined

For most applications $P_{I/O} < P_{INT}$ and can be neglected. An approximate relationship between P_D and T_J (if $P_{I/O}$ is neglected) is:

$$P_D = K \div (T_J + 273^\circ\text{C}) \tag{2}$$

Solving equations 1 and 2 for K gives:

$$K = P_D + (T_A + 273^\circ\text{C}) + \Theta_{\theta A} \times P_D^2 \tag{3}$$

where K is a constant pertaining to the particular part. K can be determined from equation (3) by measuring P_D (at equilibrium) for a known T_A . Using this value of K, the values of P_D and T_J can be obtained by solving equations (1) and (2) iteratively for any value of T_A .

A

Table A-4 16.78 MHz Clock Control Timing

(V_{DD} and $V_{DDSYN} = 5.0 \text{ Vdc} \pm 10\%$, $V_{SS} = 0 \text{ Vdc}$, $T_A = T_L$ to T_H , 32.768 kHz reference)

Num	Characteristic	Symbol	Min	Max	Unit
1	PLL Reference Frequency Range	f_{ref}	25	50	kHz
2	System Frequency ¹	f_{sys}	dc	16.78	MHz
	On-Chip PLL System Frequency		0.131	16.78	
	External Clock Operation		dc	16.78	
3	PLL Lock Time ^{2,3,4,5}	t_{pll}	—	20	ms
4	VCO Frequency ⁶	f_{VCO}		2 ($f_{sys} \text{ max}$)	MHz
5	Limp Mode Clock Frequency SYNCR X bit = 0 SYNCR X bit = 1	f_{limp}	—	$f_{sys} \text{ max}/2$ $f_{sys} \text{ max}$	MHz
			—		
6	CLKOUT Stability ^{2,3,4,7} Short term (5 μs interval) Long term (500 μs interval)	C_{stab}	-0.5	0.5	%
			-0.05	0.05	

Table A-4a 20.97 MHz Clock Control Timing

(V_{DD} and $V_{DDSYN} = 5.0 \text{ Vdc} \pm 5\%$, $V_{SS} = 0 \text{ Vdc}$, $T_A = T_L$ to T_H ,
32.768 kHz reference)

Num	Characteristic	Symbol	Min	Max	Unit
1	PLL Reference Frequency Range	f_{ref}	25	50	kHz
2	System Frequency ¹		dc	20.97	
	On-Chip PLL System Frequency	f_{sys}	0.131	20.97	MHz
	External Clock Operation		dc	20.97	
3	PLL Lock Time ^{2,3,4,5}	t_{pll}	—	20	ms
4	VCO Frequency ⁶	f_{VCO}	—	2 ($f_{sys \text{ max}}$)	MHz
5	Limp Mode Clock Frequency	f_{limp}	—	$f_{sys \text{ max}}/2$	MHz
	SYNCR X bit = 0		—	$f_{sys \text{ max}}$	
	SYNCR X bit = 1		—		
6	CLKOUT Stability ^{2,3,4,7}	C_{stab}			%
	Short term (5 μs interval)		-0.5	0.5	
	Long term (500 μs interval)		-0.05	0.05	

Notes for Tables A-4 and A-4a

- All internal registers retain data at 0 Hz
- This parameter is periodically sampled rather than 100% tested.
- Assumes that a low-leakage external filter network is used to condition clock synthesizer input voltage. Total external resistance from the XFC pin due to external leakage must be greater than 15 M Ω to guarantee this specification. Filter network geometry can vary depending upon operating environment (See **4.3 System Clock**).
- Proper layout procedures must be followed to achieve specifications.
- Assumes that stable V_{DDSYN} is applied, and that the crystal oscillator is stable. Lock time is measured from the time V_{DD} and V_{DDSYN} are valid until \overline{RESET} is released. This specification also applies to the period required for PLL lock after changing the W and Y frequency control bits in the synthesizer control register (SYNCR) while the PLL is running, and to the period required for the clock to lock after LPSTOP.
- Internal VCO frequency (f_{VCO}) is determined by SYNCR W and Y bit values. The SYNCR X bit controls a divide-by-two circuit that is not in the synthesizer feedback loop. When X = 0, the divider is enabled, and $f_{sys} = f_{VCO} \div 4$. When X = 1, the divider is disabled, and $f_{sys} = f_{VCO} \div 2$. X must equal one when operating at maximum specified f_{sys} .
- Stability is the average deviation from the programmed frequency measured over the specified interval at maximum f_{sys} . Measurements are made with the device powered by filtered supplies and clocked by a stable external clock signal. Noise injected into the PLL circuitry via V_{DDSYN} and V_{SS} and variation in crystal oscillator frequency increase the C_{stab} percentage for a given interval. When clock stability is a critical constraint on control system operation, this parameter should be measured during functional testing of the final system.

Table A-5 16.78 MHz DC Characteristics
 $(V_{DD} \text{ and } V_{DDSYN} = 5.0 \text{ Vdc} \pm 10\%, V_{SS} = 0 \text{ Vdc}, T_A = T_L \text{ to } T_H)$

Num	Characteristic	Symbol	Min	Max	Unit
1	Input High Voltage	V_{IH}	0.7 (V_{DD})	$V_{DD} + 0.3$	V
2	Input Low Voltage	V_{IL}	$V_{SS} - 0.3$	0.2 (V_{DD})	V
3	Input Hysteresis ¹	V_{HYS}	0.5	—	V
4	Input Leakage Current ² $V_{in} = V_{DD} \text{ or } V_{SS}$ Input-only pins	I_{in}	-2.5	2.5	μA
5	High Impedance (Off-State) Leakage Current ² $V_{in} = V_{DD} \text{ or } V_{SS}$ All input/output and output pins	I_{OZ}	-2.5	2.5	μA
6	CMOS Output High Voltage ^{2, 3} $I_{OH} = -10.0 \mu\text{A}$ Group 1, 2, 4 input/output and all output pins	V_{OH}	$V_{DD} - 0.2$	—	V
7	CMOS Output Low Voltage ² $I_{OL} = 10.0 \mu\text{A}$ Group 1, 2, 4 input/output and all output pins	V_{OL}	—	0.2	V
8	Output High Voltage ^{2, 3} $I_{OH} = -0.8 \text{ mA}$ Group 1, 2, 4 input/output and all output pins	V_{OH}	$V_{DD} - 0.8$	—	V
9	Output Low Voltage ² $I_{OL} = 1.6 \text{ mA}$ Group 1 I/O Pins, CLKOUT, FREEZE/QUOT, IPIPE $I_{OL} = 5.3 \text{ mA}$ Group 2 and Group 4 I/O Pins, CSBOOT, BG/CS $I_{OL} = 12 \text{ mA}$ Group 3	V_{OL}	—	0.4	V
10	Three State Control Input High Voltage	V_{IHTSC}	1.6 (V_{DD})	9.1	V
11	Data Bus Mode Select Pull-up Current ⁵ $V_{in} = V_{IL}$ DATA[15:0] $V_{in} = V_{IH}$ DATA[15:0]	I_{MSP}	— -15	-120 —	μA
12	V_{DD} Supply Current ⁶ RUN ⁴ LPSTOP, 32.768 kHz crystal, VCO Off (STSIM = 0) LPSTOP (External clock input frequency = maximum f_{sys})	I_{DD} S_{IDD} S_{IDD}	— — —	124 350 5	mA μA mA
13	Clock Synthesizer Operating Voltage	V_{DDSYN}	4.5	5.5	V
14	V_{DDSYN} Supply Current ⁶ 32.768 kHz crystal, VCO on, maximum f_{sys} External Clock, maximum f_{sys} LPSTOP, 32.768 kHz crystal, VCO off (STSIM = 0) 32.768 kHz crystal, V_{DD} powered down	I_{DDSYN} I_{DDSYN} S_{IDDSYN} I_{DDSYN}	— — — —	1 5 150 100	mA mA μA μA
15	Power Dissipation ⁸	P_D	—	690	mW
16	Input Capacitance ^{2, 9} All input-only pins All input/output pins	C_{in}	— —	10 20	pF
17	Load Capacitance ² Group 1 I/O Pins and CLKOUT, FREEZE/QUOT, IPIPE Group 2 I/O Pins and CSBOOT, BG/CS Group 3 I/O pins Group 4 I/O pins	C_L	— — — —	90 100 130 200	pF

A

Table A-5a 20.97 MHz DC Characteristics
 $(V_{DD} \text{ and } V_{DDSYN} = 5.0 \text{ Vdc} \pm 5\%, V_{SS} = 0 \text{ Vdc}, T_A = T_L \text{ to } T_H)$

Num	Characteristic	Symbol	Min	Max	Unit
1	Input High Voltage	V_{IH}	0.7 (V_{DD})	$V_{DD} + 0.3$	V
2	Input Low Voltage	V_{IL}	$V_{SS} - 0.3$	0.2 (V_{DD})	V
3	Input Hysteresis ¹	V_{HYS}	0.5	—	V
4	Input Leakage Current ² $V_{in} = V_{DD}$ or V_{SS} Input-only pins	I_{in}	-2.5	2.5	μA
5	High Impedance (Off-State) Leakage Current ² $V_{in} = V_{DD}$ or V_{SS} All input/output and output pins	I_{OZ}	-2.5	2.5	μA
6	CMOS Output High Voltage ^{2, 3} $I_{OH} = -10.0 \mu\text{A}$ Group 1, 2, 4 input/output and all output pins	V_{OH}	$V_{DD} - 0.2$	—	V
7	CMOS Output Low Voltage ² $I_{OL} = 10.0 \mu\text{A}$ Group 1, 2, 4 input/output and all output pins	V_{OL}	—	0.2	V
8	Output High Voltage ^{2, 3} $I_{OH} = -0.8 \text{ mA}$ Group 1, 2, 4 input/output and all output pins	V_{OH}	$V_{DD} - 0.8$	—	V
9	Output Low Voltage ² $I_{OL} = 1.6 \text{ mA}$ Group 1 I/O Pins, CLKOUT, FREEZE/QUOT, IPIPE $I_{OL} = 5.3 \text{ mA}$ Group 2 and Group 4 I/O Pins, CSBOOT, BG/CS $I_{OL} = 12 \text{ mA}$ Group 3	V_{OL}	—	0.4	V
10	Three State Control Input High Voltage	V_{IHTSC}	1.6 (V_{DD})	9.1	V
11	Data Bus Mode Select Pull-up Current ⁵ $V_{in} = V_{IL}$ DATA[15:0] $V_{in} = V_{IH}$ DATA[15:0]	I_{MSP}	— -15	-120 —	μA
12	V_{DD} Supply Current ⁶ RUN ⁴ LPSTOP, 32.768 kHz crystal, VCO Off (STSIM = 0) LPSTOP (External clock input frequency = maximum f_{sys})	I_{DD} S_{IDD} S_{IDD}	— — —	140 350 5	mA μA mA
13	Clock Synthesizer Operating Voltage	V_{DDSYN}	4.75	5.25	V
14	V_{DDSYN} Supply Current ⁶ 32.768 kHz crystal, VCO on, maximum f_{sys} External Clock, maximum f_{sys} LPSTOP, 32.768 kHz crystal, VCO off (STSIM = 0) 32.768 kHz crystal, V_{DD} powered down	I_{DDSYN} I_{DDSYN} S_{IDDSYN} I_{DDSYN}	— — — —	2 6 150 100	mA mA μA μA
15	Power Dissipation ⁷	P_D	—	766	mW
16	Input Capacitance ^{2, 8} All input-only pins All input/output pins	C_{in}	— —	10 20	pF
17	Load Capacitance ² Group 1 I/O Pins and CLKOUT, FREEZE/QUOT, IPIPE Group 2 I/O Pins and CSBOOT, BG/CS Group 3 I/O pins Group 4 I/O pins	C_L	— — — —	90 100 130 200	pF

Notes for Tables A-5 and A-5a

1. Applies to:

- Port E [7:4] — SIZ[1:0], \overline{AS} , \overline{DS}
- Port F [7:0] — \overline{IRQ} [7:1], MODCLK
- Port GP [7:0] — IC4/OC5/OC1, IC[3:1], OC[4:1]/OC1
- Port QS [7:0] — TXD, PCS[3:1], $\overline{EPCS0/SS}$, SCK, MOSI, MISO
BKPT/DSCLK, IFETCH, RESET, RXD, $\overline{TSTME/TSC}$
EXTAL (when PLL enabled)

2. Input-Only Pins: EXTAL, $\overline{TSTME/TSC}$, \overline{BKPT} , RXD

Output-Only Pins: \overline{CSBOOT} , $\overline{BG/CS}$, CLKOUT, FREEZE/QUOT, \overline{IPIPE}

Input/Output Pins:

- Group 1: Port GP [7:0] — IC4/OC5/OC1, IC[3:1], OC[4:1]/OC1
DATA[15:0], IFETCH
- Group 2 : Port C [6:0] — ADDR[22:19]/ \overline{CS} [9:6], FC[2:0]/ \overline{CS} [5:3]
Port E [7:0] — SIZ[1:0], \overline{AS} , \overline{DS} , AVEC, \overline{RMC} , \overline{DSACK} [1:0]
Port F [7:0] — \overline{IRQ} [7:1], MODCLK
Port QS [7:3] — TXD, PCS[3:1], $\overline{EPCS0/SS}$
ADDR23/ $\overline{CS10/ECLK}$, ADDR[18:0], R/W, BERR, $\overline{BR/CS0}$, $\overline{BGACK/CS2}$
- Group 3: HALT, RESET
- Group 4: MISO, MOSI, SCK

3. Does not apply to \overline{HALT} and \overline{RESET} because they are open drain pins. Does not apply to Port QS [7:0] (TXD, PCS[3:1], $\overline{EPCS0/SS}$, SCK, MOSI, MISO) in wired-OR mode.

4. Current measured with system clock frequency of 16.78 MHz, all modules active.

5. Use of an active pulldown device is recommended.

6. Total operating current is the sum of the appropriate I_{DD} and I_{DDSYN} values. I_{DD} values include supply currents for device modules powered by V_{DDE} and V_{DDI} pins.

7. Power dissipation measured at specified system clock frequency, all modules active. Power dissipation can be calculated using the expression:

$$P_D = \text{Maximum } V_{DD} (I_{DD} + I_{DDSYN})$$

I_{DD} includes supply currents for all device modules powered by V_{DDE} and V_{DDI} pins.

8. This parameter is periodically sampled rather than 100% tested.

A

Table A-6 16.78 MHz AC Timing
 $(V_{DD} \text{ and } V_{DDSYN} = 5.0 \text{ Vdc} \pm 10\%, V_{SS} = 0 \text{ Vdc}, T_A = T_L \text{ to } T_H)$

Num	Characteristic	Symbol	Min	Max	Unit
F1	Frequency of Operation (32.768 kHz crystal) ²	f	0.13	16.78	MHz
1	Clock Period	t _{cyc}	59.6	—	ns
1A	ECLK Period	t _{E_{cyc}}	476	—	ns
1B	External Clock Input Period ³	t _{X_{cyc}}	59.6	—	ns
2, 3	Clock Pulse Width	t _{CW}	24	—	ns
2A, 3A	ECLK Pulse Width	t _{ECW}	236	—	ns
2B, 3B	External Clock Input High/Low Time ³	t _{XCHL}	29.8	—	ns
4, 5	Clock Rise and Fall Time	t _{Crf}	—	5	ns
4A, 5A	Rise and Fall Time — All Outputs except CLKOUT	t _{rf}	—	8	ns
4B, 5B	External Clock Rise and Fall Time ⁴	t _{XCrf}	—	5	ns
6	Clock High to Address, FC, SIZE, RMC Valid	t _{CHAV}	0	29	ns
7	Clock High to Address, Data, FC, SIZE, RMC High Impedance	t _{CHAZx}	0	59	ns
8	Clock High to Address, FC, SIZE, RMC Invalid	t _{CHAZn}	0	—	ns
9	Clock Low to \overline{AS} , \overline{DS} , \overline{CS} Asserted	t _{CLSA}	2	25	ns
9A	\overline{AS} to \overline{DS} or \overline{CS} Asserted (Read) ⁵	t _{STSA}	-15	15	ns
9C	Clock Low to IFETCH, IPIPE Asserted	t _{CLIA}	2	22	ns
11	Address, FC, SIZE, RMC Valid to \overline{AS} , \overline{CS} Asserted	t _{AVSA}	15	—	ns
12	Clock Low to \overline{AS} , \overline{DS} , \overline{CS} Negated	t _{CLSN}	2	29	ns
12A	Clock Low to IFETCH, IPIPE Negated	t _{CLIN}	2	22	ns
13	\overline{AS} , \overline{DS} , \overline{CS} Negated to Address, FC, SIZE Invalid (Address Hold)	t _{SNAI}	15	—	ns
14	\overline{AS} , \overline{CS} Width Asserted	t _{SWA}	100	—	ns
14A	\overline{DS} , \overline{CS} Width Asserted (Write)	t _{SWAW}	45	—	ns
14B	\overline{AS} , \overline{CS} Width Asserted (Fast Write Cycle)	t _{SWDW}	40	—	ns
15	\overline{AS} , \overline{DS} , \overline{CS} Width Negated ⁶	t _{SN}	40	—	ns
16	Clock High to \overline{AS} , \overline{DS} , R/W High Impedance	t _{CHSZ}	—	59	ns
17	\overline{AS} , \overline{DS} , \overline{CS} Negated to R/W Negated	t _{SNRN}	15	—	ns
18	Clock High to R/W High	t _{CHRH}	0	29	ns
20	Clock High to R/W Low	t _{CHRL}	0	29	ns
21	R/W Asserted to \overline{AS} , \overline{CS} Asserted	t _{RAAA}	15	—	ns
22	R/W Low to \overline{DS} , \overline{CS} Asserted (Write)	t _{RASA}	70	—	ns
23	Clock High to Data Out Valid	t _{CHDO}	—	29	ns
24	Data Out Valid to Negating Edge of \overline{AS} , \overline{CS}	t _{DVASN}	15	—	ns
25	\overline{DS} , \overline{CS} Negated to Data Out Invalid (Data Out Hold)	t _{SND_{OI}}	15	—	ns
26	Data Out Valid to \overline{DS} , \overline{CS} Asserted (Write)	t _{DVSA}	15	—	ns
27	Data In Valid to Clock Low (Data Setup)	t _{DICL}	5	—	ns
27A	Late BERR, HALT Asserted to Clock Low (Setup Time)	t _{BELCL}	20	—	ns
28	\overline{AS} , \overline{DS} Negated to DSACK[1:0], BERR, HALT, AVEC Negated	t _{SNDN}	0	80	ns
29	\overline{DS} , \overline{CS} Negated to Data In Invalid (Data In Hold) ⁷	t _{SNDI}	0	—	ns
29A	\overline{DS} , \overline{CS} Negated to Data In High Impedance ^{7, 8}	t _{SHDI}	—	55	ns
30	CLKOUT Low to Data In Invalid (Fast Cycle Hold) ⁷	t _{CLDI}	15	—	ns
30A	CLKOUT Low to Data In High Impedance ⁷	t _{CLDH}	—	90	ns
31	DSACK[1:0] Asserted to Data In Valid ⁹	t _{DADI}	—	50	ns
33	Clock Low to \overline{BG} Asserted/Negated	t _{CLBAN}	—	29	ns
35	BR Asserted to \overline{BG} Asserted (RMC Not Asserted) ¹⁰	t _{BRAGA}	1	—	t _{cyc}
37	BGACK Asserted to \overline{BG} Negated	t _{GAGN}	1	2	t _{cyc}

Table A-6 16.78 MHz AC Timing, (Continued)
 $(V_{DD} \text{ and } V_{DDSYN} = 5.0 \text{ Vdc} \pm 10\%, V_{SS} = 0 \text{ Vdc}, T_A = T_L \text{ to } T_H)$

Num	Characteristic	Symbol	Min	Max	Unit
39	\overline{BG} Width Negated	t_{GH}	2	—	t_{cyc}
39A	\overline{BG} Width Asserted	t_{GA}	1	—	t_{cyc}
46	R/\overline{W} Width Asserted (Write or Read)	t_{RWA}	150	—	ns
46A	R/\overline{W} Width Asserted (Fast Write or Read Cycle)	t_{RWAS}	90	—	ns
47A	Asynchronous Input Setup Time BR, BGACK, DSACK[1:0], BERR, \overline{AVEC} , \overline{HALT}	t_{AIST}	5	—	ns
47B	Asynchronous Input Hold Time	t_{AIHT}	15	—	ns
48	DSACK[1:0] Asserted to \overline{BERR} , \overline{HALT} Asserted ¹¹	t_{DABA}	—	30	ns
53	Data Out Hold from Clock High	t_{DOCH}	0	—	ns
54	Clock High to Data Out High Impedance	t_{CHDH}	—	28	ns
55	R/\overline{W} Asserted to Data Bus Impedance Change	t_{RADC}	40	—	ns
56	RESET Pulse Width (Reset Instruction)	t_{HRPW}	512	—	t_{cyc}
57	\overline{BERR} Negated to \overline{HALT} Negated (Rerun)	t_{BNHN}	0	—	ns
70	Clock Low to Data Bus Driven (Show)	t_{SCLDD}	0	29	ns
71	Data Setup Time to Clock Low (Show)	t_{SCLDS}	15	—	ns
72	Data Hold from Clock Low (Show)	t_{SCLDH}	10	—	ns
73	\overline{BKPT} Input Setup Time	t_{BKST}	15	—	ns
74	\overline{BKPT} Input Hold Time	t_{BKHT}	10	—	ns
75	Mode Select Setup Time	t_{MSS}	20	—	t_{cyc}
76	Mode Select Hold Time	t_{MSH}	0	—	ns
77	RESET Assertion Time ¹²	t_{RSTA}	4	—	t_{cyc}
78	RESET Rise Time ¹³	t_{RSTR}	—	10	t_{cyc}

Table A-6a 20.97 MHz AC Timing
 $(V_{DD} \text{ and } V_{DDSYN} = 5.0 \text{ Vdc} \pm 5\%, V_{SS} = 0 \text{ Vdc}, T_A = T_L \text{ to } T_H)$

Num	Characteristic	Symbol	Min	Max	Unit
F1	Frequency of Operation (32.768 kHz crystal) ²	f	0.13	20.97	MHz
1	Clock Period	t_{cyc}	47.7	—	ns
1A	ECLK Period	t_{Ecyc}	381	—	ns
1B	External Clock Input Period ³	t_{Xcyc}	47.7	—	ns
2, 3	Clock Pulse Width	t_{CW}	18.8	—	ns
2A, 3A	ECLK Pulse Width	t_{ECW}	183	—	ns
2B, 3B	External Clock Input High/Low Time ³	t_{XCHL}	23.8	—	ns
4, 5	Clock Rise and Fall Time	t_{Crf}	—	5	ns
4A, 5A	Rise and Fall Time — All Outputs except CLKOUT	t_{rf}	—	8	ns
4B, 5B	External Clock Rise and Fall Time ⁴	t_{XCrf}	—	5	ns
6	Clock High to Address, FC, SIZE, \overline{RMC} Valid	t_{CHAV}	0	23	ns
7	Clock High to Address, Data, FC, SIZE, \overline{RMC} High Impedance	t_{CHAZx}	0	47	ns
8	Clock High to Address, FC, SIZE, \overline{RMC} Invalid	t_{CHAZn}	0	—	ns
9	Clock Low to \overline{AS} , \overline{DS} , \overline{CS} Asserted	t_{CLSA}	0	23	ns
9A	\overline{AS} to \overline{DS} or \overline{CS} Asserted (Read) ⁵	t_{STSA}	-10	10	ns
9C	Clock Low to \overline{IFETCH} , \overline{IPIPE} Asserted	t_{CLIA}	2	22	ns
11	Address, FC, SIZE, \overline{RMC} Valid to \overline{AS} , \overline{CS} Asserted	t_{AVSA}	10	—	ns
12	Clock Low to \overline{AS} , \overline{DS} , \overline{CS} Negated	t_{CLSN}	2	23	ns
12A	Clock Low to \overline{IFETCH} , \overline{IPIPE} Negated	t_{CLIN}	2	22	ns
13	\overline{AS} , \overline{DS} , \overline{CS} Negated to Address, FC, SIZE Invalid (Address Hold)	t_{SNAI}	10	—	ns

Table A-6a 20.97 MHz AC Timing, (Continued)
 $(V_{DD} \text{ and } V_{DDSYN} = 5.0 \text{ Vdc} \pm 5\%, V_{SS} = 0 \text{ Vdc}, T_A = T_L \text{ to } T_H)$

Num	Characteristic	Symbol	Min	Max	Unit
14	\overline{AS} , \overline{CS} Width Asserted	t_{SWA}	80	—	ns
14A	\overline{DS} , \overline{CS} Width Asserted (Write)	t_{SWAW}	36	—	ns
14B	\overline{AS} , \overline{CS} Width Asserted (Fast Write Cycle)	t_{SWDW}	32	—	ns
15	\overline{AS} , \overline{DS} , \overline{CS} Width Negated ⁶	t_{SN}	32	—	ns
16	Clock High to \overline{AS} , \overline{DS} , R/\overline{W} High Impedance	t_{CHSZ}	—	47	ns
17	\overline{AS} , \overline{DS} , \overline{CS} Negated to R/\overline{W} Negated	t_{SNRN}	10	—	ns
18	Clock High to R/\overline{W} High	t_{CHRH}	0	23	ns
20	Clock High to R/\overline{W} Low	t_{CHRL}	0	23	ns
21	R/\overline{W} Asserted to \overline{AS} , \overline{CS} Asserted	t_{RAAA}	10	—	ns
22	R/\overline{W} Low to \overline{DS} , \overline{CS} Asserted (Write)	t_{RASA}	54	—	ns
23	Clock High to Data Out Valid	t_{CHDO}	—	23	ns
24	Data Out Valid to Negating Edge of \overline{AS} , \overline{CS}	t_{DVASN}	10	—	ns
25	\overline{DS} , \overline{CS} Negated to Data Out Invalid (Data Out Hold)	t_{SNDIOI}	10	—	ns
26	Data Out Valid to \overline{DS} , \overline{CS} Asserted (Write)	t_{DVSA}	10	—	ns
27	Data In Valid to Clock Low (Data Setup)	t_{DICL}	5	—	ns
27A	Late \overline{BERR} , \overline{HALT} Asserted to Clock Low (Setup Time)	t_{BELCL}	15	—	ns
28	\overline{AS} , \overline{DS} Negated to $\overline{DSACK}[1:0]$, \overline{BERR} , \overline{HALT} , \overline{AVEC} Negated	t_{SNDN}	0	60	ns
29	\overline{DS} , \overline{CS} Negated to Data In Invalid (Data In Hold) ⁷	t_{SNDI}	0	—	ns
29A	\overline{DS} , \overline{CS} Negated to Data In High Impedance ^{7, 8}	t_{SHDI}	—	48	ns
30	CLKOUT Low to Data In Invalid (Fast Cycle Hold) ⁷	t_{CLDI}	10	—	ns
30A	CLKOUT Low to Data In High Impedance ⁷	t_{CLDH}	—	72	ns
31	$\overline{DSACK}[1:0]$ Asserted to Data In Valid ⁹	t_{DADI}	—	46	ns
33	Clock Low to \overline{BG} Asserted/Negated	t_{CLBAN}	—	23	ns
35	\overline{BR} Asserted to \overline{BG} Asserted (\overline{RMC} Not Asserted) ¹⁰	t_{BRAGA}	1	—	t_{cyc}
37	\overline{BGACK} Asserted to \overline{BG} Negated	t_{GAGN}	1	2	t_{cyc}
39	\overline{BG} Width Negated	t_{GH}	2	—	t_{cyc}
39A	\overline{BG} Width Asserted	t_{GA}	1	—	t_{cyc}
46	R/\overline{W} Width Asserted (Write or Read)	t_{RWA}	115	—	ns
46A	R/\overline{W} Width Asserted (Fast Write or Read Cycle)	t_{RWAS}	70	—	ns
47A	Asynchronous Input Setup Time \overline{BR} , \overline{BGACK} , $\overline{DSACK}[1:0]$, \overline{BERR} , \overline{AVEC} , \overline{HALT}	t_{AIST}	5	—	ns
47B	Asynchronous Input Hold Time	t_{AIHT}	12	—	ns
48	$\overline{DSACK}[1:0]$ Asserted to \overline{BERR} , \overline{HALT} Asserted ¹¹	t_{DABA}	—	30	ns
53	Data Out Hold from Clock High	t_{DOCH}	0	—	ns
54	Clock High to Data Out High Impedance	t_{CHDH}	—	23	ns
55	R/\overline{W} Asserted to Data Bus Impedance Change	t_{RADC}	32	—	ns
56	RESET Pulse Width (Reset Instruction)	t_{HRPW}	512	—	t_{cyc}
57	\overline{BERR} Negated to \overline{HALT} Negated (Rerun)	t_{BNHN}	0	—	ns
70	Clock Low to Data Bus Driven (Show)	t_{SCLDD}	0	23	ns
71	Data Setup Time to Clock Low (Show)	t_{SCLDS}	10	—	ns
72	Data Hold from Clock Low (Show)	t_{SCLDH}	10	—	ns
73	\overline{BKPT} Input Setup Time	t_{BKST}	10	—	ns
74	\overline{BKPT} Input Hold Time	t_{BKHT}	10	—	ns
75	Mode Select Setup Time	t_{MSS}	20	—	t_{cyc}
76	Mode Select Hold Time	t_{MSH}	0	—	ns
77	RESET Assertion Time ¹²	t_{RSTA}	4	—	t_{cyc}
78	RESET Rise Time ^{13,14}	t_{RSTR}	—	10	t_{cyc}

Notes for Tables A-6 and A-6a:

1. All AC timing is shown with respect to 20% V_{DD} and 70% V_{DD} levels unless otherwise noted.
2. Minimum system clock frequency is four times the crystal frequency, subject to specified limits.
3. When an external clock is used, minimum high and low times are based on a 50% duty cycle. The minimum allowable t_{Xcyc} period is reduced when the duty cycle of the external clock signal varies. The relationship between external clock input duty cycle and minimum t_{Xcyc} is expressed:

$$\text{Minimum } t_{Xcyc} \text{ period} = \text{minimum } t_{XCHL} / (50\% - \text{external clock input duty cycle tolerance}).$$
4. Parameters for an external clock signal applied while the internal PLL is disabled (MODCLK pin held low during reset). Does not pertain to an external VCO reference applied while the PLL is enabled (MODCLK pin held high during reset). When the PLL is enabled, the clock synthesizer detects successive transitions of the reference signal. If transitions occur within the correct clock period, rise/fall times and duty cycle are not critical.
5. Specification 9A is the worst-case skew between \overline{AS} and \overline{DS} or \overline{CS} . The amount of skew depends on the relative loading of these signals. When loads are kept within specified limits, skew will not cause \overline{AS} and \overline{DS} to fall outside the limits shown in specification 9.
6. If multiple chip selects are used, \overline{CS} width negated (specification 15) applies to the time from the negation of a heavily loaded chip select to the assertion of a lightly loaded chip select. The \overline{CS} width negated specification between multiple chip selects does not apply to chip selects being used for synchronous ECLK cycles.
7. Hold times are specified with respect to \overline{DS} or \overline{CS} on asynchronous reads and with respect to CLKOUT on fast cycle reads. The user is free to use either hold time.
8. Maximum value is equal to $(t_{cyc} / 2) + 25 \text{ ns}$.
9. If the asynchronous setup time (specification 47A) requirements are satisfied, the $\overline{DSACK}[1:0]$ low to data setup time (specification 31) and $\overline{DSACK}[1:0]$ low to \overline{BERR} low setup time (specification 48) can be ignored. The data must only satisfy the data-in to clock low setup time (specification 27) for the following clock cycle. \overline{BERR} must satisfy only the late \overline{BERR} low to clock low setup time (specification 27A) for the following clock cycle.
10. To ensure coherency during every operand transfer, \overline{BG} will not be asserted in response to \overline{BR} until after all cycles of the current operand transfer are complete and \overline{RMC} is negated.
11. In the absence of $\overline{DSACK}[1:0]$, \overline{BERR} is an asynchronous input using the asynchronous setup time (specification 47A).
12. After external \overline{RESET} negation is detected, a short transition period (approximately $2 t_{cyc}$) elapses, then the SIM drives \overline{RESET} low for $512 t_{cyc}$.
13. External assertion of the \overline{RESET} input can overlap internally-generated resets. To insure that an external reset is recognized in all cases, \overline{RESET} must be asserted for at least 590 CLKOUT cycles.
14. External logic must pull \overline{RESET} high during this period in order for normal MCU operation to begin.
15. Address access time = $(2.5 + WS) t_{cyc} - t_{CHAV} - t_{D1CL}$
 Chip select access time = $(2 + WS) t_{cyc} - t_{CLSA} - t_{D1CL}$
 Where: WS = number of wait states. When fast termination is used (2 clock bus) WS = -1.

A

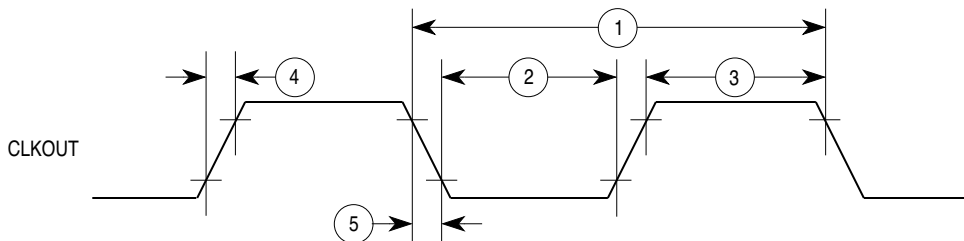

NOTE: Timing shown with respect to 20% and 70% V_{DD} .

68300 CLKOUT TIM

NOTE: Timing shown with respect to 20% and 70% V_{DD} .

Figure A-1 CLKOUT Output Timing Diagram

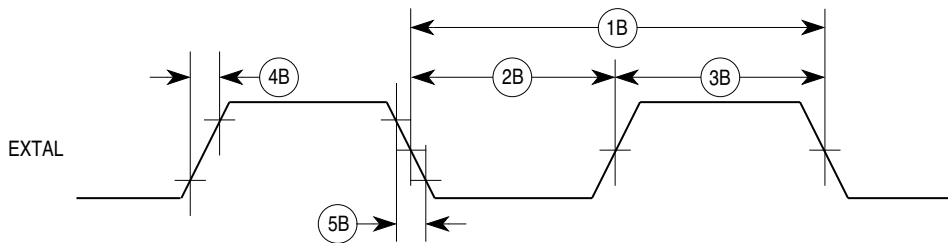

68300 EXT CLK INPUT TIM

NOTE: Timing shown with respect to 20% and 70% V_{DD} . Pulse width shown with respect to 50% V_{DD} .

Figure A-2 External Clock Input Timing Diagram

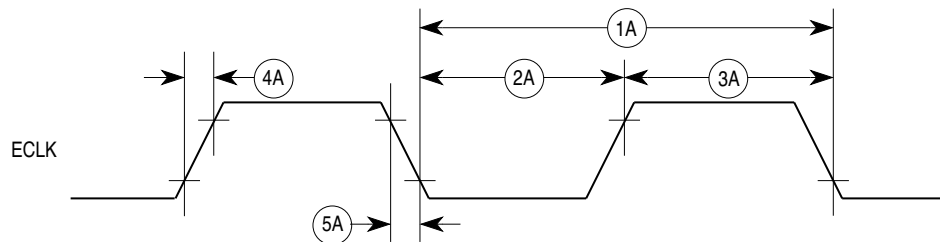

68300 ECLK OUTPUT TIM

NOTE: Timing shown with respect to 20% and 70% V_{DD} .

Figure A-3 ECLK Output Timing Diagram

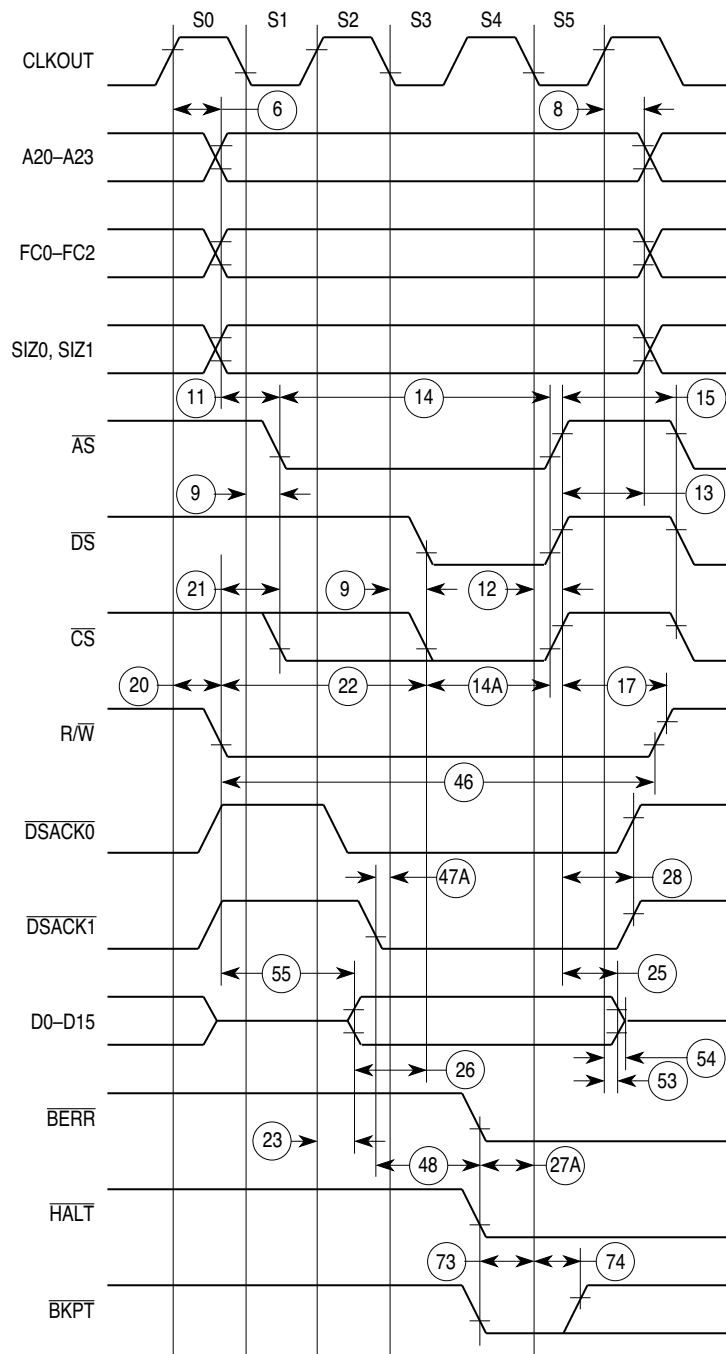

68300 RD CYC TIM

A

Figure A-4 Read Cycle Timing Diagram

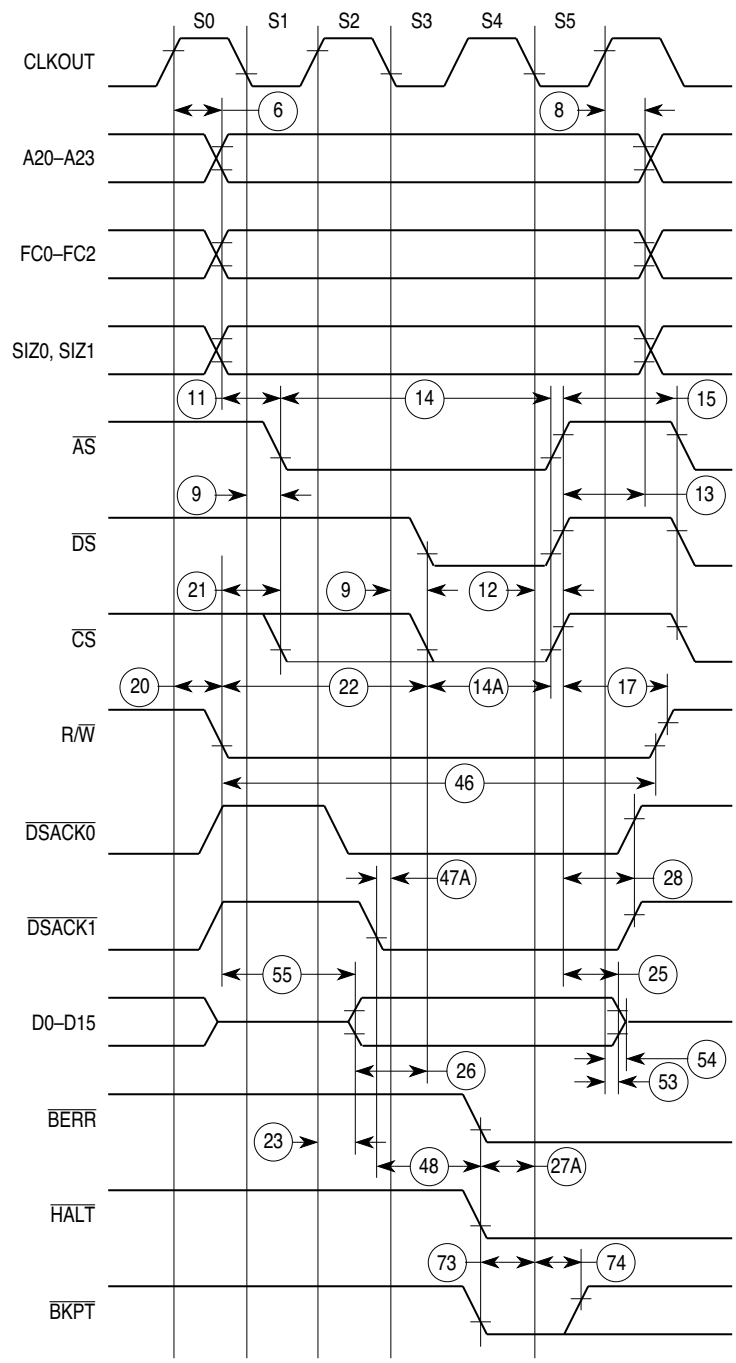

68300 WR CYC TIM

Figure A-5 Write Cycle Timing Diagram

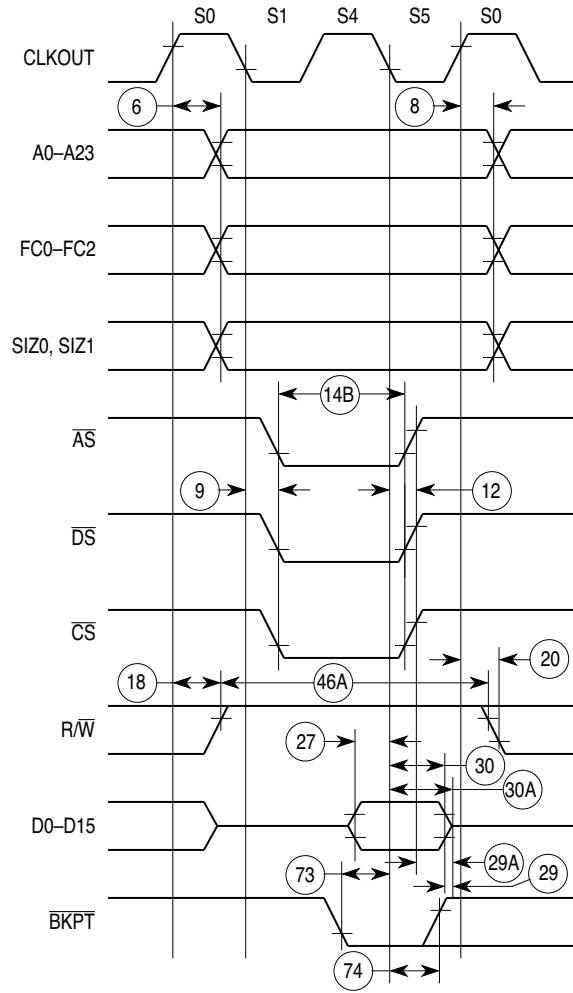

68300 FAST RD CYC TIM

Figure A-6 Fast Termination Read Cycle Timing Diagram

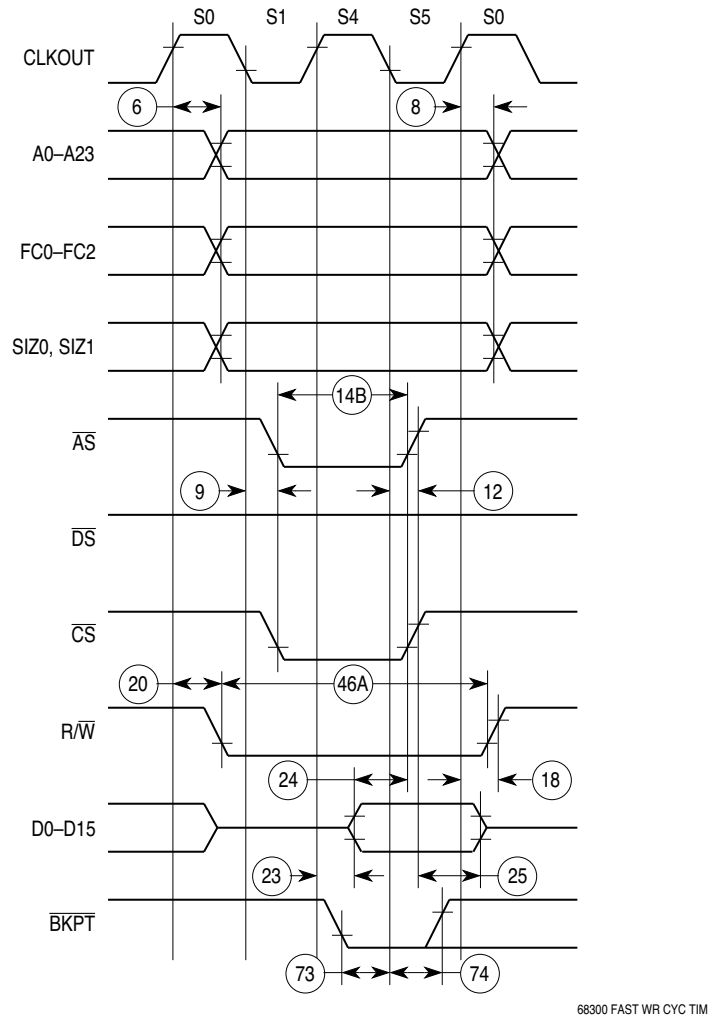
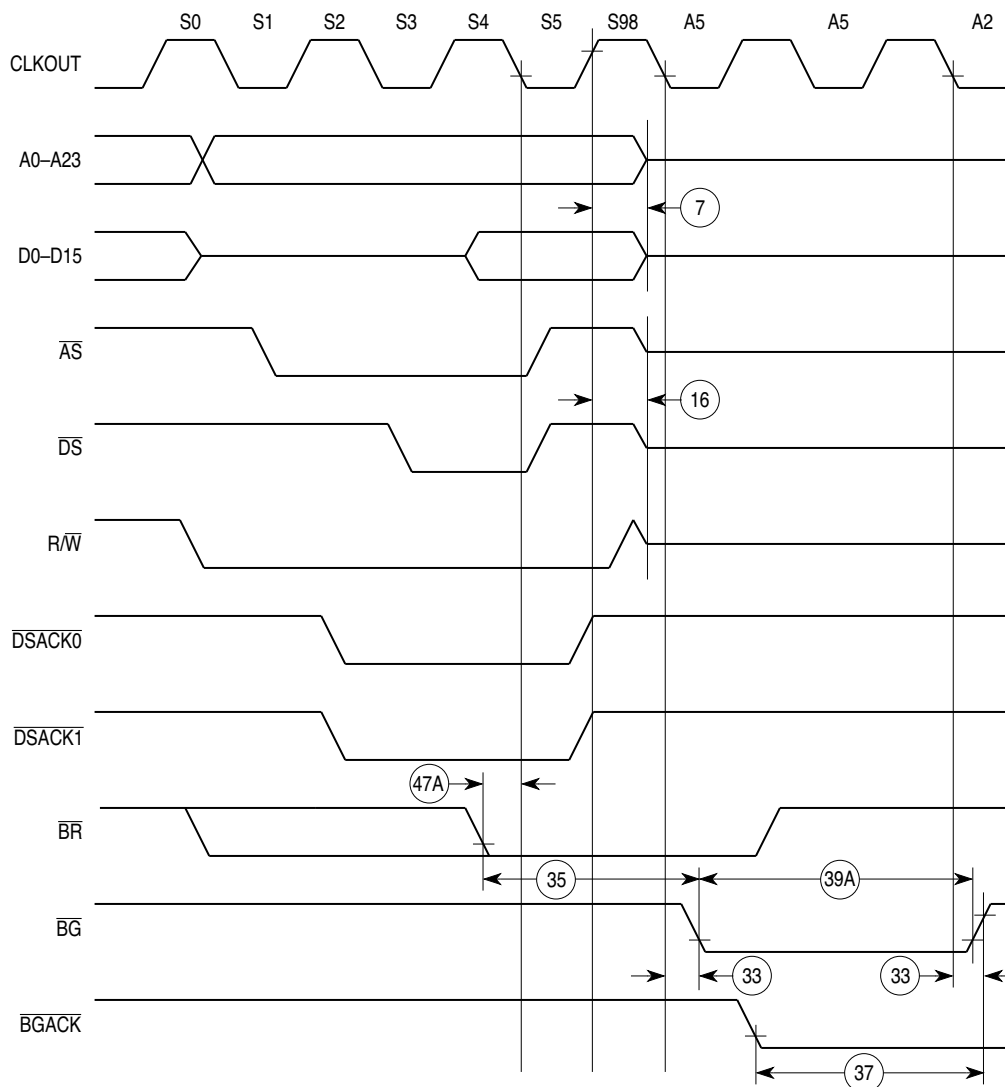

Figure A-7 Fast Termination Write Cycle Timing Diagram



68300 BUS ARB TIM

Figure A-8 Bus Arbitration Timing Diagram — Active Bus Case

A

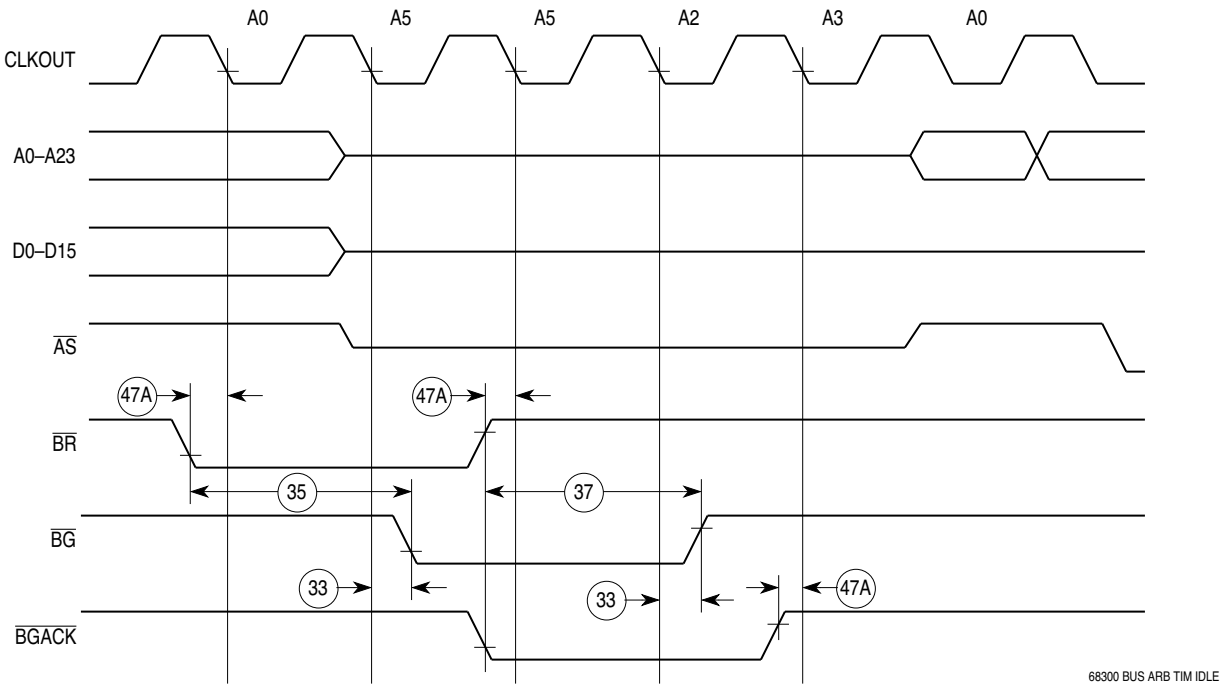
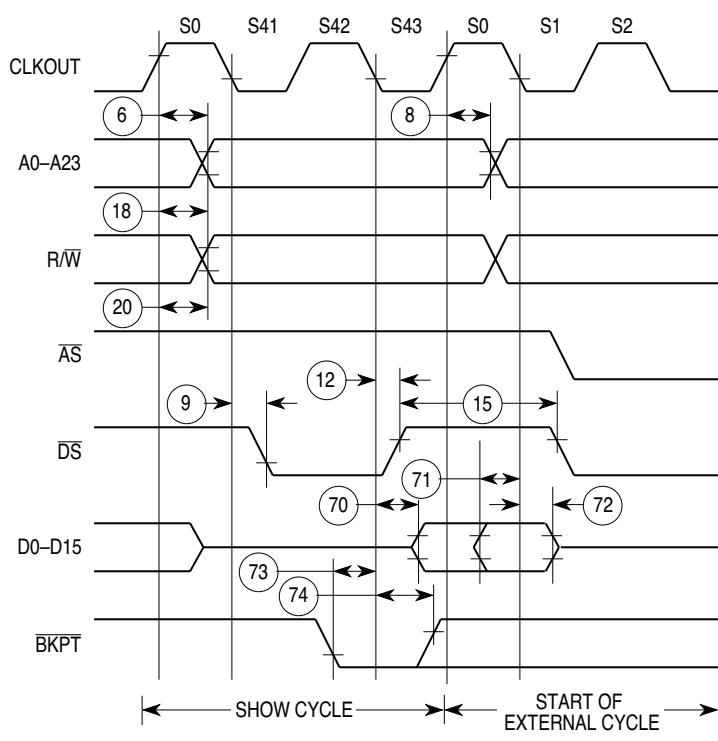
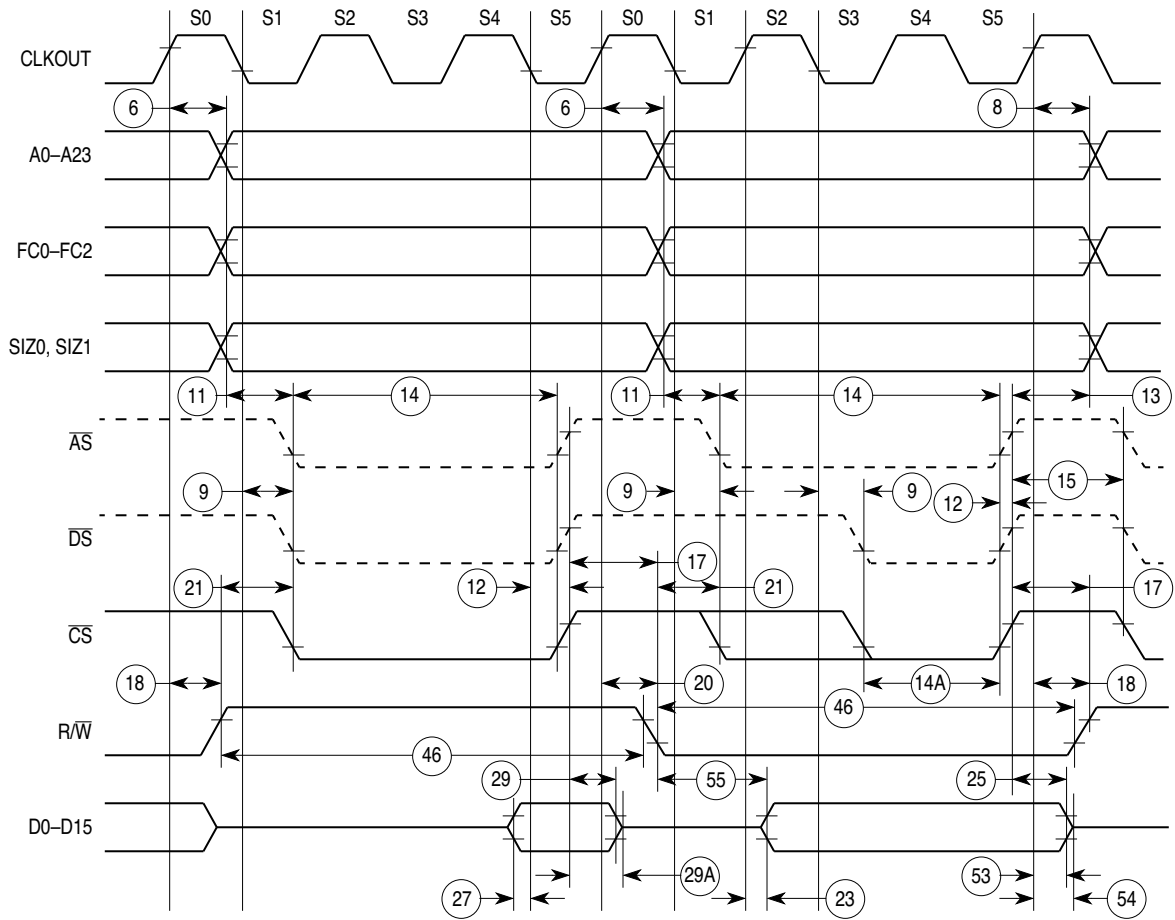

Figure A-9 Bus Arbitration Timing Diagram — Idle Bus Case



NOTE: Show cycles can stretch during S42 when bus accesses take longer than two cycles due to wait-state insertion by IMB modules.

Figure A-10 Show Cycle Timing Diagram



68300 CHIP SEL TIM

NOTE: \overline{AS} and \overline{DS} timing shown for reference only.

Figure A-11 Chip Select Timing Diagram

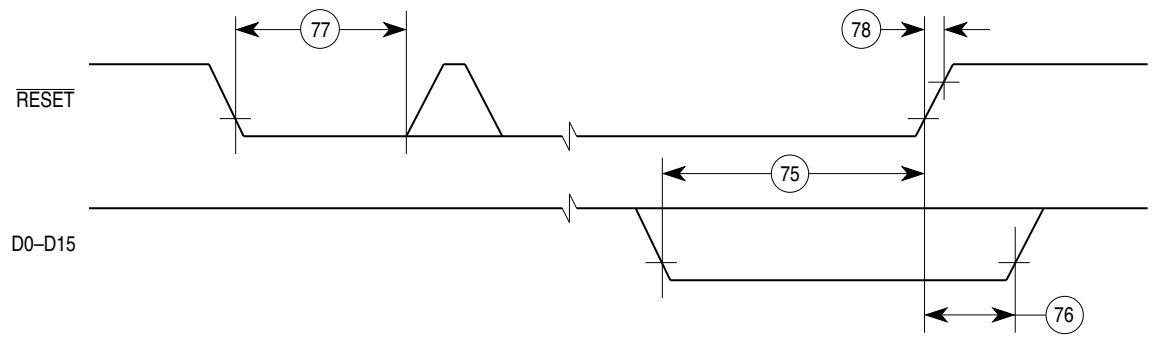

68300 RST/MODE SEL TIM

Figure A-12 Reset and Mode Select Timing Diagram

Table A-7 Background Debugging Mode Timing

($V_{DD} = 5.0 \text{ Vdc} \pm 10\%$, $V_{SS} = 0 \text{ Vdc}$, $T_A = T_L \text{ to } T_H$)

Num	Characteristic	Symbol	Min	Max	Unit
B0	DSI Input Setup Time	t_{DSISU}	15	—	ns
B1	DSI Input Hold Time	t_{DSIH}	10	—	ns
B2	DSCLK Setup Time	t_{DSCSU}	15	—	ns
B3	DSCLK Hold Time	t_{DSCH}	10	—	ns
B4	DSO Delay Time	t_{DSOD}	—	25	ns
B5	DSCLK Cycle Time	t_{DSCCYC}	2	—	t_{cyc}
B6	CLKOUT High to FREEZE Asserted/Negated	t_{FRZAN}	—	50	ns
B7	CLKOUT High to $\overline{\text{IFETCH}}$ High Impedance	t_{IFZ}	—	50	ns
B8	CLKOUT High to $\overline{\text{IFETCH}}$ Valid	t_{IF}	—	50	ns
B9	DSCLK Low Time	t_{DSCLO}	1	—	t_{cyc}
B10	FREEZE Asserted to $\overline{\text{IFETCH}}$ Valid	t_{FRZIF}	TBD	—	t_{cyc}

Notes:

1. All AC timing is shown with respect to 20% V_{DD} and 70% V_{DD} levels unless otherwise noted.

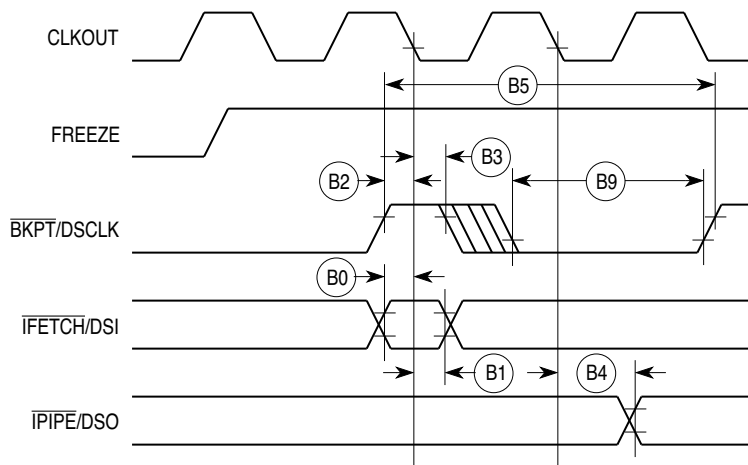

68300 BKGD DBM SER COM TIM

Figure A-13 Background Debugging Mode Timing Diagram — Serial Communication

A

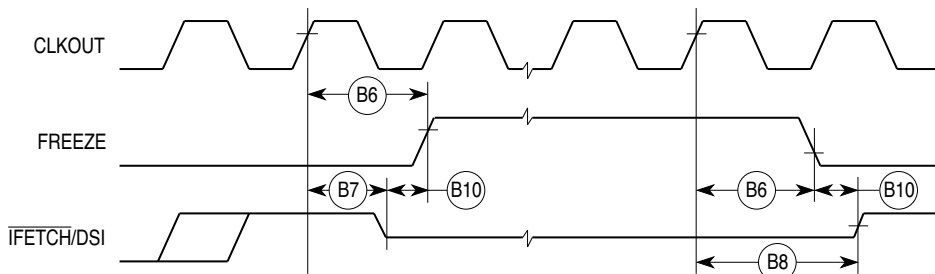

68300 BKGD DBM FRZ TIM

Figure A-14 Background Debugging Mode Timing Diagram —Freeze Assertion

Table A-8 16.78 MHz ECLK Bus Timing
 $(V_{DD} = 5.0 \text{ Vdc} \pm 10\%, V_{SS} = 0 \text{ Vdc}, T_A = T_L \text{ to } T_H)$

Num	Characteristic	Symbol	Min	Max	Unit
E1	ECLK Low to Address Valid ²	t_{EAD}	—	60	ns
E2	ECLK Low to Address Hold	t_{EAH}	15	—	ns
E3	ECLK Low to \overline{CS} Valid (\overline{CS} delay)	t_{ECSD}	—	150	ns
E4	ECLK Low to \overline{CS} Hold	t_{ECSH}	15	—	ns
E5	\overline{CS} Negated Width	t_{ECSN}	30	—	ns
E6	Read Data Setup Time	t_{EDSR}	30	—	ns
E7	Read Data Hold Time	t_{EDHR}	5	—	ns
E8	ECLK Low to Data High Impedance	t_{EDHZ}	—	60	ns
E9	\overline{CS} Negated to Data Hold (Read)	t_{ECDH}	0	—	ns
E10	\overline{CS} Negated to Data High Impedance	t_{ECDZ}	—	1	t_{cyc}
E11	ECLK Low to Data Valid (Write)	t_{EDDW}	—	2	t_{cyc}
E12	ECLK Low to Data Hold (Write)	t_{EDHW}	15	—	ns
E13	Address Access Time (Read) ³	t_{EACC}	386	—	ns
E14	Chip Select Access Time (Read) ⁴	t_{EACS}	296	—	ns
E15	Address Setup Time	t_{EAS}	1/2	—	t_{cyc}

Table A-8a 20.97 MHz ECLK Bus Timing
 $(V_{DD} = 5.0 \text{ Vdc} \pm 5\%, V_{SS} = 0 \text{ Vdc}, T_A = T_L \text{ to } T_H)$

Num	Characteristic	Symbol	Min	Max	Unit
E1	ECLK Low to Address Valid ²	t_{EAD}	—	48	ns
E2	ECLK Low to Address Hold	t_{EAH}	10	—	ns
E3	ECLK Low to \overline{CS} Valid (\overline{CS} delay)	t_{ECSD}	—	120	ns
E4	ECLK Low to \overline{CS} Hold	t_{ECSH}	10	—	ns
E5	\overline{CS} Negated Width	t_{ECSN}	25	—	ns
E6	Read Data Setup Time	t_{EDSR}	25	—	ns
E7	Read Data Hold Time	t_{EDHR}	5	—	ns
E8	ECLK Low to Data High Impedance	t_{EDHZ}	—	48	ns
E9	\overline{CS} Negated to Data Hold (Read)	t_{ECDH}	0	—	ns
E10	\overline{CS} Negated to Data High Impedance	t_{ECDZ}	—	1	t_{cyc}
E11	ECLK Low to Data Valid (Write)	t_{EDDW}	—	2	t_{cyc}
E12	ECLK Low to Data Hold (Write)	t_{EDHW}	10	—	ns
E13	Address Access Time (Read) ³	t_{EACC}	308	—	ns
E14	Chip Select Access Time (Read) ⁴	t_{EACS}	236	—	ns
E15	Address Setup Time	t_{EAS}	1/2	—	t_{cyc}

Notes for Tables A-8 and A-8a:

1. All AC timing is shown with respect to 20% V_{DD} and 70% V_{DD} levels unless otherwise noted.
2. When the previous bus cycle is not an ECLK cycle, the address may be valid before ECLK goes low.
3. Address access time = $t_{Eacc} - t_{EAD} - t_{EDSR}$.
4. Chip select access time = $t_{Eacc} - t_{ECSD} - t_{EDSR}$.

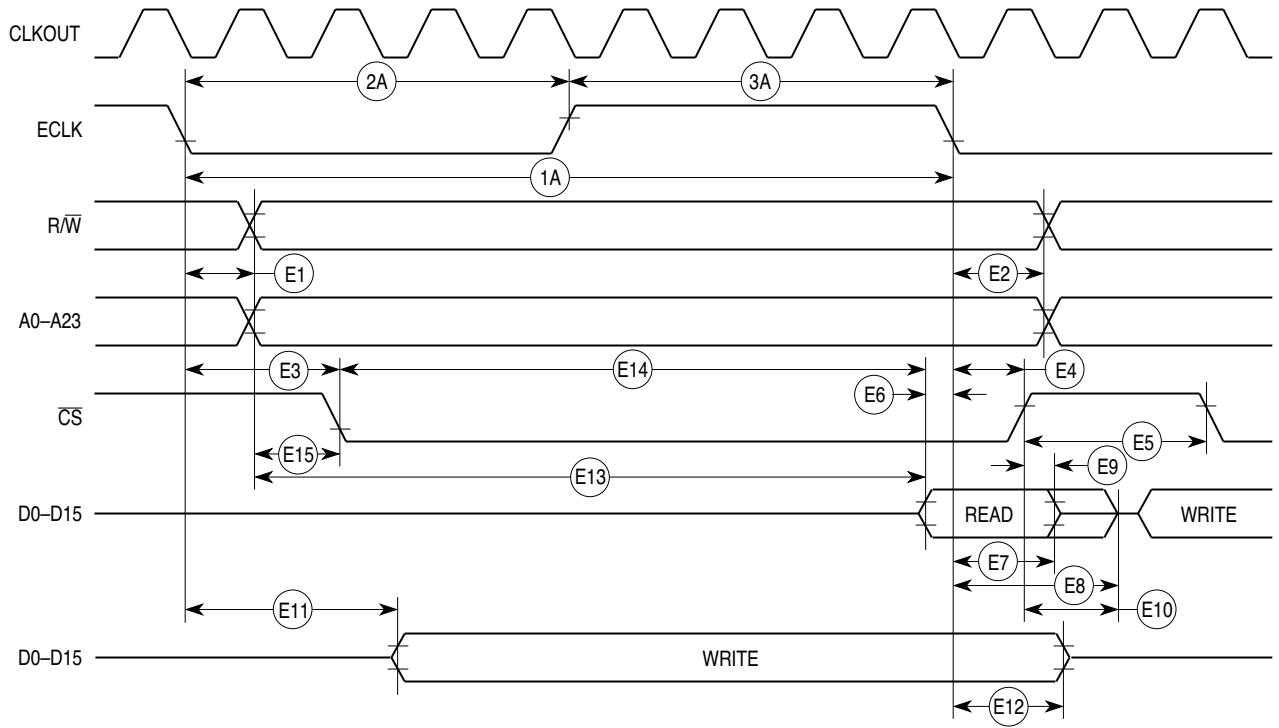

68300 E CYCLE TIM

NOTE: Shown with ECLK = system clock/8 — EDIV bit in clock synthesizer control register (SYNCR) = 0.

Figure A-15 ECLK Timing Diagram

Table A-9 QSPI Timing
 $(V_{DD} = 5.0 V_{dc} \pm 10\%, V_{SS} = 0 V_{dc}, T_A = T_L \text{ to } T_H, 200 \text{ pF load on all QSPI pins})$

Num	Function	Symbol	Min	Max	Unit
	Operating Frequency Master Slave	f_{op}	DC DC	1/4 1/4	System Clock Frequency System Clock Frequency
1	Cycle Time Master Slave	t_{qcy}	4 4	510 —	t_{cyc} t_{cyc}
2	Enable Lead Time Master Slave	t_{lead}	2 2	128 —	t_{cyc} t_{cyc}
3	Enable Lag Time Master Slave	t_{lag}	— 2	1/2 —	SCK t_{cyc}
4	Clock (SCK) High or Low Time Master Slave ²	t_{sw}	$2 t_{cyc} - 60$ $2 t_{cyc} - n$	$255 t_{cyc}$ —	ns ns
5	Sequential Transfer Delay Master Slave (Does Not Require Deselect)	t_{td}	17 13	8192 —	t_{cyc} t_{cyc}
6	Data Setup Time (Inputs) Master Slave	t_{su}	30 20	— —	ns ns
7	Data Hold Time (Inputs) Master Slave	t_{hi}	0 20	— —	ns ns
8	Slave Access Time	t_a	—	1	t_{cyc}
9	Slave MISO Disable Time	t_{dis}	—	2	t_{cyc}
10	Data Valid (after SCK Edge) Master Slave	t_v	— —	50 50	ns ns
11	Data Hold Time (Outputs) Master Slave	t_{ho}	0 0	— —	ns ns
12	Rise Time Input ³ Output	t_{ri} t_{ro}	— —	2 30	μ s ns
13	Fall Time Input ³ Output	t_{fi} t_{fo}	— —	2 30	μ s ns

Notes:

- 1 All AC timing is shown with respect to 20% V_{DD} and 70% V_{DD} levels unless otherwise noted.
2. In formula, n = External SCK rise + External SCK fall time
3. Data can be recognized properly with longer transition times as long as MOSI/MISO signals from external sources are at valid V_{OH}/V_{OL} prior to SCK transitioning between valid V_{OL} and V_{OH} . Due to process variation, logic decision point voltages of the data and clock signals can differ, which can corrupt data if slower transition times are used.

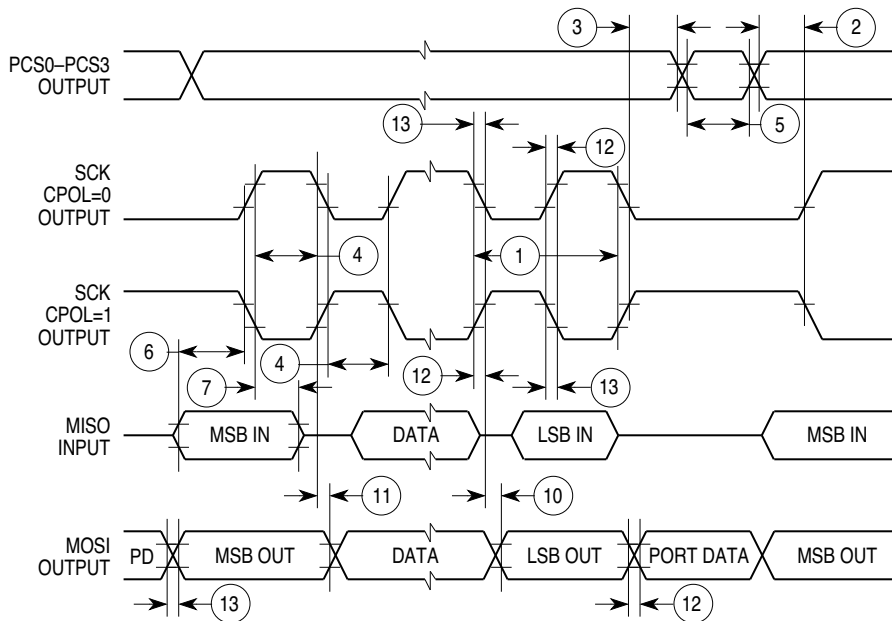

68300 QSPI T MAST CPHA0

A

Figure A-16 QSPI Timing — Master, CPHA = 0

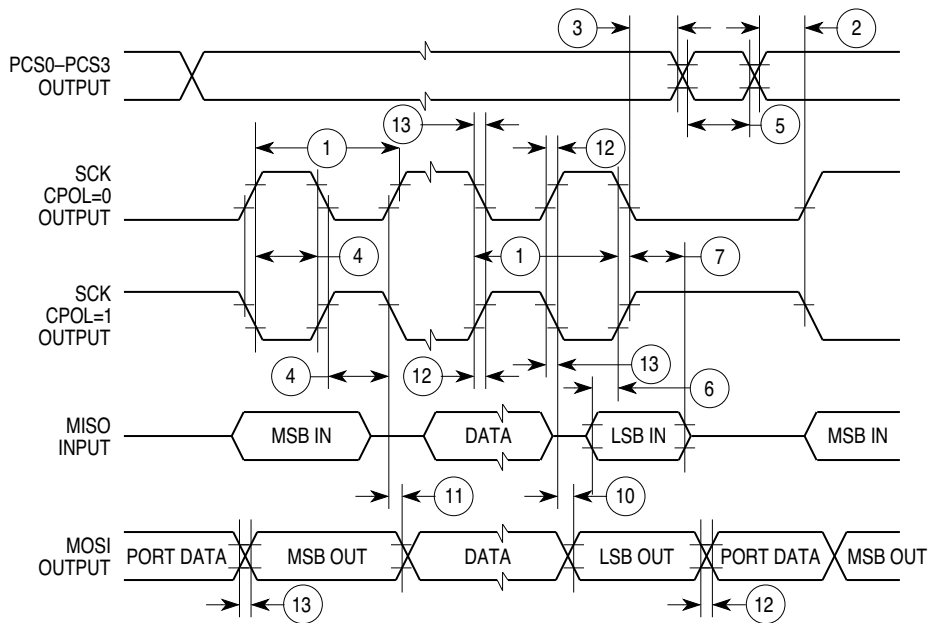

68300 QSPI T MAST CPHA1

Figure A-17 QSPI Timing — Master, CPHA = 1

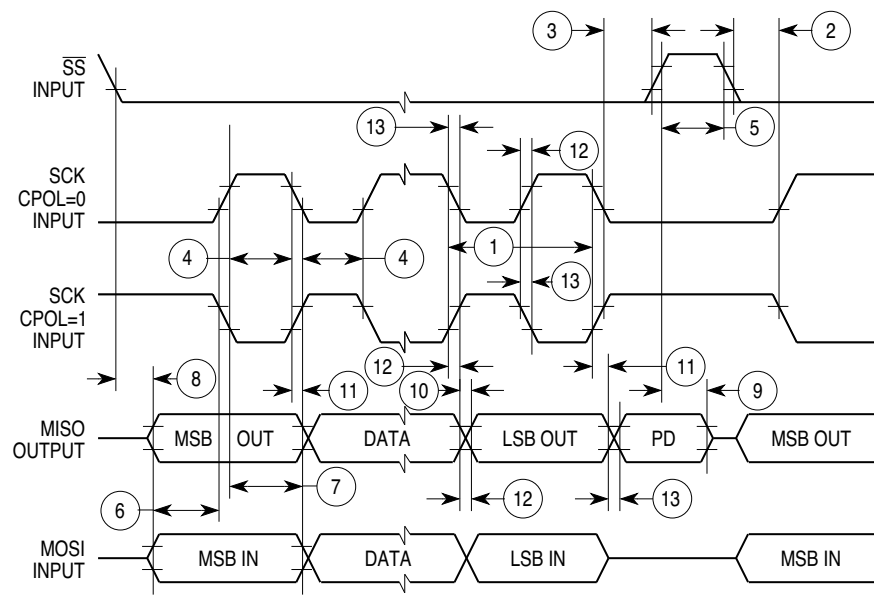

68300 QSPI T SLV CPHA0

Figure A-18 QSPI Timing — Slave, CPHA = 0

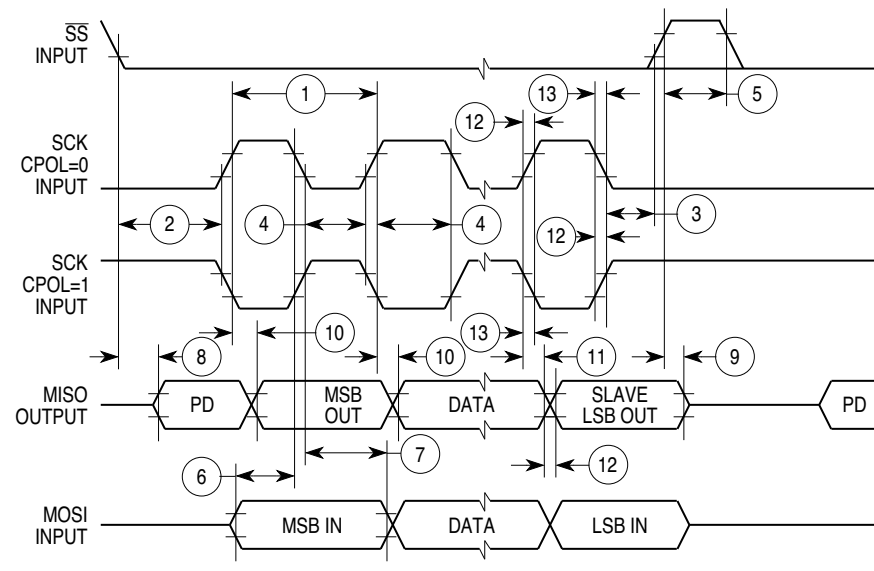

68300 QSPI T SLV CPHA1

Figure A-19 QSPI Timing — Slave, CPHA = 1



APPENDIX B MECHANICAL DATA AND ORDERING INFORMATION

This section contains detailed information to be used as a guide when ordering.

MC68331 is available in either a 132-pin or 144-pin plastic surface mount package. This appendix provides package pin assignment drawings and ordering information.

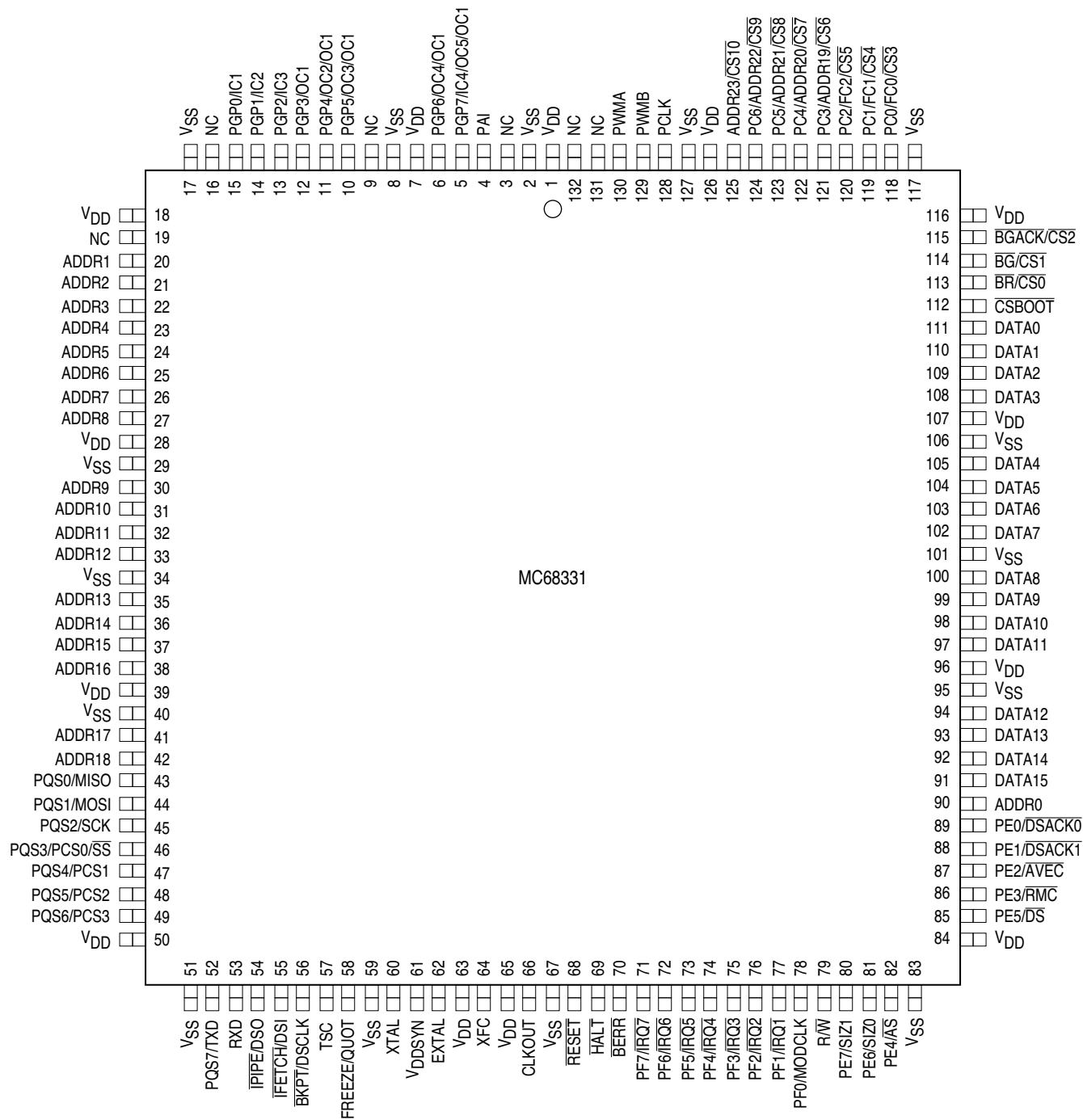

331 132-PIN QFP

Figure B-1 132-Pin Plastic Surface Mount Package Pin Assignments

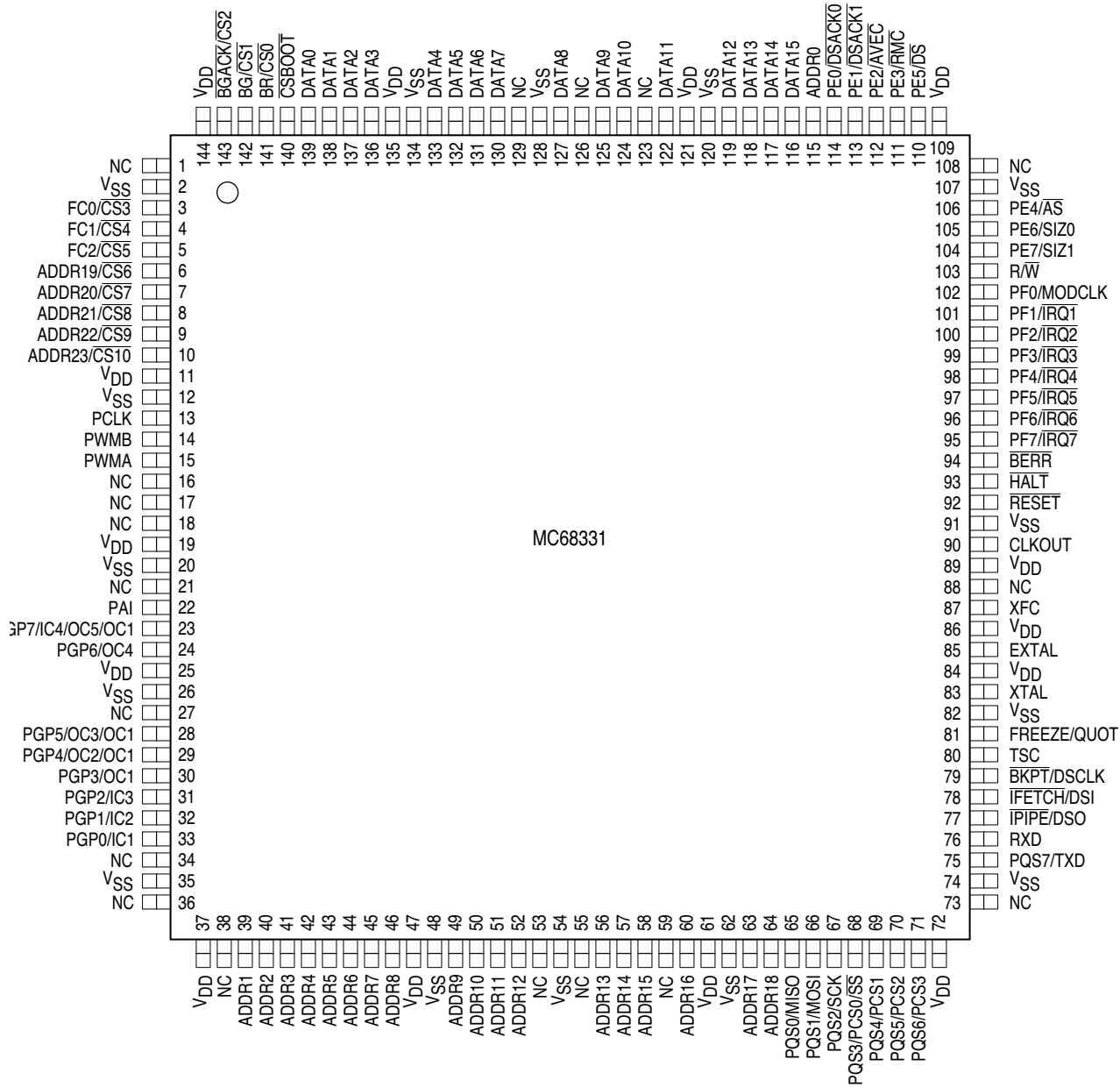

B

331 144-PIN QFP

Figure B-2 144-Pin Plastic Surface Mount Package Pin Assignments

Table B-1 MCU Ordering Information

Package Type	Temperature	Frequency (MHz)	Package Order Quantity	Order Number
132-Pin PQFP	-40 to +85 °C	16 MHz	2 pc tray	SPAKMC331CFC16
			36 pc tray	MC68331CFC16*
		20 MHz	2 pc tray	SPAKMC331CFC20
			36 pc tray	MC68331CFC20*
	-40 to +105 °C	16 MHz	2 pc tray	SPAKMC331VFC16
			36 pc tray	MC68331VFC16*
		20 MHz	2 pc tray	SPAKMC331VFC20
			36 pc tray	MC68331VFC20*
	-40 to +125 °C	16 MHz	2 pc tray	SPAKMC331MFC16
			36 pc tray	MC68331MFC16*
		20 MHz	2 pc tray	SPAKMC331MFC20
			36 pc tray	MC68331MFC20*
144-Pin QFP	-40 to +85 °C	16 MHz	2 pc tray	SPAKMC331CFV16
			44 pc tray	MC68331CFV16*
		20 MHz	2 pc tray	SPAKMC331CFV20
			44 pc tray	MC68331CFV20*
	-40 to +105 °C	16 MHz	2 pc tray	SPAKMC331VFCV16
			44 pc tray	MC68331VFCV16*
		20 MHz	2 pc tray	SPAKMC331VFCV20
			44 pc tray	MC68331VFCV20*
	-40 to +125 °C	16 MHz	2 pc tray	SPAKMC331MFV16
			44 pc tray	MC68331MFV16*
		20 MHz	2 pc tray	SPAKMC331MFV20
			44 pc tray	MC68331MFV20*
144-Pin TQFP	-40 to +85 °C	16 MHz	2 pc tray	SPAKMC331CPV16
			60 pc tray	MC68331CPV16*
		20 MHz	2 pc tray	SPAKMC331CPV20
			60 pc tray	MC68331CPV20*
	-40 to +105 °C	16 MHz	2 pc tray	SPAKMC331VPV16
			60 pc tray	MC68331VPV16*
		20 MHz	2 pc tray	SPAKMC331VPV20
			60 pc tray	MC68331VPV20*
	-40 to +125 °C	16 MHz	2 pc tray	SPAKMC331MPV16
			60 pc tray	MC68331MPV16*
		20 MHz	2 pc tray	SPAKMC331MPV20
			60 pc tray	MC68331MPV20*

*Quantity orders are available as shown in Table B-2. Contact your Freescale representative for ordering numbers.

Table B-2 Quantity Order Suffix

FC	FV	PV
36	44	60
180	220	300
360	440	600

APPENDIX C DEVELOPMENT SUPPORT

This section serves as a brief reference to Freescale development tools for the MC68331 microcontroller. Information provided is complete as of the time of publication, but new systems and software are continually being developed. In addition, a growing number of third-party tools are available. The Freescale *MCU Tool Box* (MCUTLBX/D Rev. C) provides an up-to-date list of development tools. Contact your Freescale representative for further information.

Table C-1 MC68331 Development Tools

Microcontroller Part Number	Modular Development System	Modular Evaluation System
MC68331	M68MMDS1632	M68MEVB1632

C.1 M68MMDS1632 Modular Development System

M68MMDS1632 Freescale Modular Development System (MMDS) is a development tool for evaluating M68HC16 and M68300 MCU-based systems. The MMDS1632 is an emulator, bus state analyzer, and control station for debugging hardware and software. A separately purchased active probe completes MMDS functionality with regard to a particular MCU or MCU family. The many active probes available let your MMDS emulate a variety of different MCUs. Contact your Freescale sales representative, who will assist you in selecting and configuring the modular system that fits your needs. A full-featured development system, the MMDS provides both in-circuit emulation and bus analysis capabilities, including:

- Real-time in-circuit emulation at maximum speed of 20 MHz (can be upgraded to 33 MHz)
- Built-in emulation memory
 - 1 Mbyte main emulation memory (fast termination, 2 bus cycle)
 - 4 Kbytes dual-port emulation memory
- Real-time bus analysis
 - Instruction disassembly
 - State-machine-controlled triggering
- Four hardware breakpoints, bitwise masking
- Analog/digital emulation
- Synchronized signal output
- Built-in AC power supply, 85–264 V, 50–60 Hz, FCC and EC EMI compliant
- RS-232 connection to host capable of communicating at 1200, 2400, 4800, 9600, 19200, 38400, or 57600 baud

C.2 M68MEVB1632 Modular Evaluation Board

M68MEVB1632 Modular Evaluation Board (MEVB) is a development tool for evaluating M68HC16 and M68300 MCU-based systems. The MEVB consists of the M68HC16MPFB modular platform board, an MCU personality board (MPB), an in-circuit debugger printed circuit board (ICD16 or ICD32), and development software. MEVB features include:

- An economical means of evaluating target systems incorporating M68HC16 and M68300 HCMOS MCU devices.
- Expansion memory sockets for installing RAM, EPROM, or EEPROM.
 - Data RAM: 32K X 16, 128K X 16, or 512K X 16
 - EPROM/EEPROM: 32K X 16, 64K X 16, 128K X 16, 256K X 16, or 512K X 16
 - Fast RAM: 32K X 16 or 128K X 16
- Background-mode operation, for detailed operation from a personal computer platform without an on-board monitor.
- Integrated assembly/editing/evaluation/programming environment for easy development.
- As many as seven software breakpoints.
- Re-usable ICD hardware for your target application debug or control.
- Two RS-232C terminal input/output (I/O) ports for user evaluation of the serial communication interface.
- Logic analyzer pod connectors.
- Port replacement unit (PRU) to rebuild I/O ports lost to address/data/control.
- On-board V_{PP} (+12 Vdc) generation for MCU and flash EEPROM programming.

APPENDIX D REGISTER SUMMARY

This appendix contains address maps, register diagrams, and bit/field definitions for the MCU. More detailed information about register function is provided in the appropriate sections of the manual.

Except for central processing unit resources, information is presented in the intermodule bus address order shown in **Table D-1**.

Table D-1 Module Address Map

Module	Size (Bytes)	Base Address
GPT	64	\$YFF900
SIM	128	\$YFFA00
QSM	512	\$YFFC00

Control registers for all the modules in the microcontroller are mapped into a 4-Kbyte block. The state of the module mapping (MM) bit in the SIM configuration register (SIMCR) determines where the control registers block is located in the system memory map. When MM = 0, register addresses range from \$7FF000 to \$7FFFFFF; when MM = 1, register addresses range from \$FFF000 to \$FFFFFF.

In the module memory maps in this appendix, the “Access” column specifies which registers are accessible at the supervisor privilege level only and which registers can be assigned to either the supervisor or user privilege level.

D.1 Central Processing Unit

CPU32 registers are not part of the module address map. The following diagram is a functional representation of CPU resources.

D

D.1.1 CPU32 Register Model

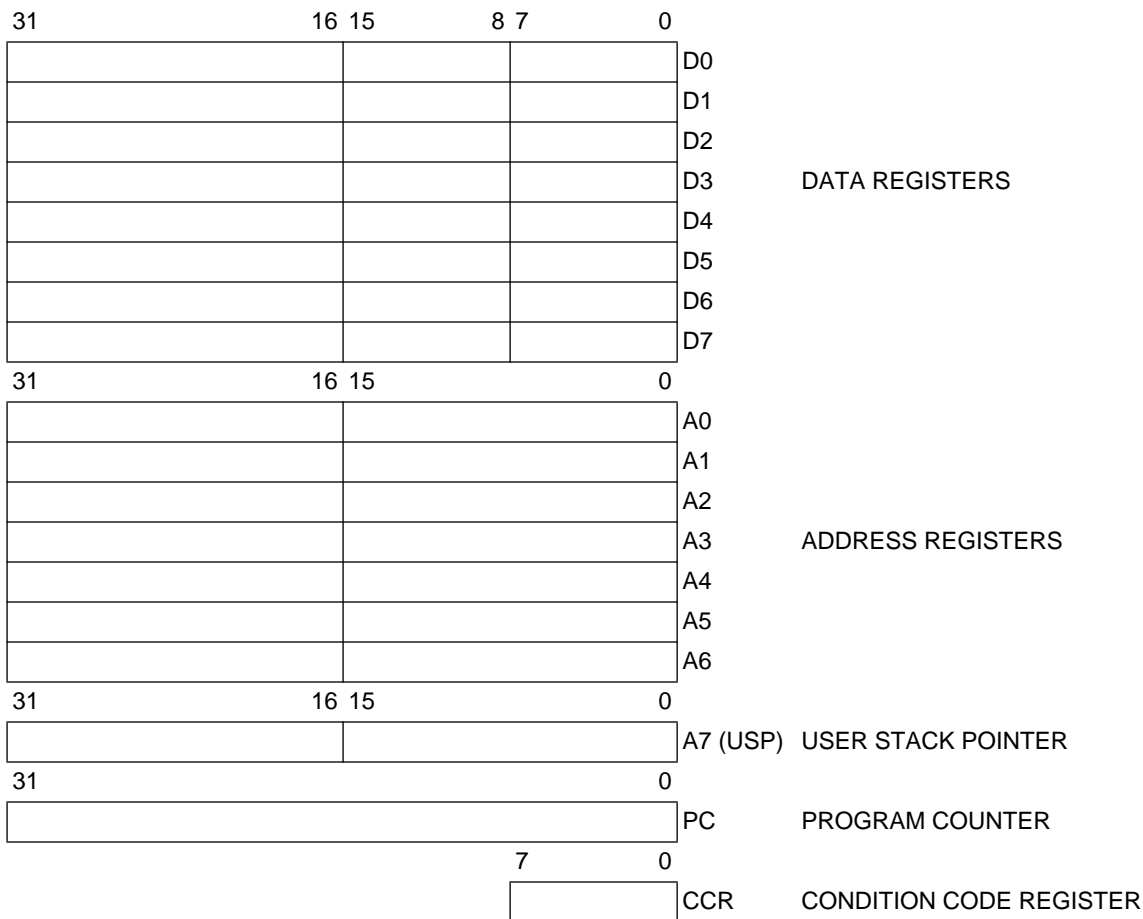

Figure D-1 User Programming Model

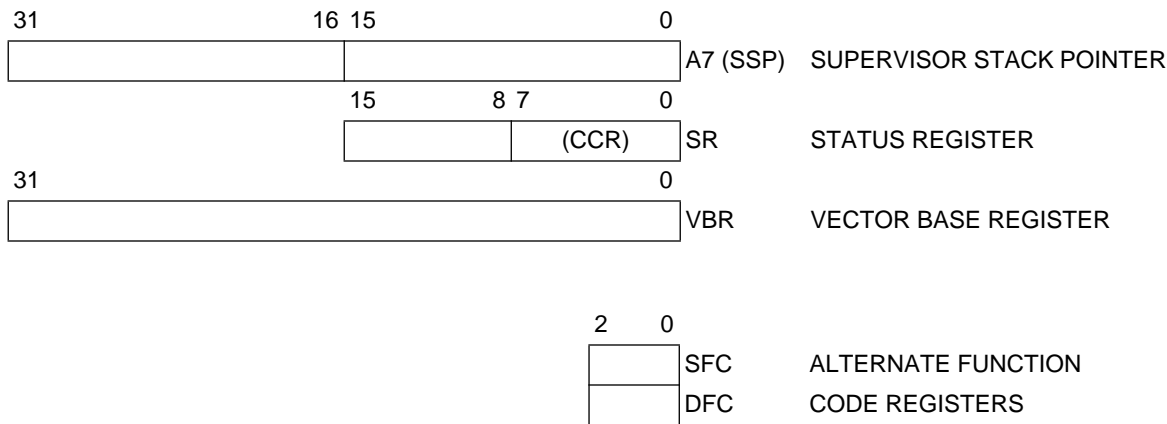

Figure D-2 Supervisor Programming Model Supplement

D.1.2 — Status Register

15	14	13	12	11	10	8	7	6	5	4	3	2	1	0	
T[1:0]		S	0	0	IP			0	0	0	X	N	Z	V	C
RESET:															
0	0	1	0	0	1	1	1	1	0	0	0	U	U	U	U

The status register (SR) contains condition codes, an interrupt priority mask, and three control bits. The condition codes are contained in the condition code register (CCR), the lower byte of the SR. (The lower and upper bytes of the status register are also referred to as the user and system bytes, respectively.) At the user privilege level, only the CCR is available. At the supervisor level, software can access the full status register.

T[1:0] — Trace Enable

- 00 = No tracing
- 01 = Trace on change of flow
- 10 = Trace on instruction execution
- 11 = Undefined; reserved

S — Supervisor/User State

- 0 = CPU operates at user privilege level
- 1 = CPU operates at supervisor privilege level

IP[2:0] — Interrupt Priority Mask

The priority value in this field (0 to 7) is used to mask interrupts.

X — Extend Flag

Used in multiple-precision arithmetic operations. In many instructions it is set to the same value as the C bit.

N — Negative Flag

Set when the MSB of a result register is set.

Z — Zero Flag

Set when all bits of a result register are zero.

V — Overflow Flag

Set when two's complement overflow occurs as the result of an operation.

C — Carry Flag

Set when a carry or borrow occurs during an arithmetic operation. Also used during shift and rotate instructions to facilitate multiple word operations.

D

D.2 General-Purpose Timer

Table D-2 displays the GPT address map. The column labeled “Access” indicates the privilege level at which the CPU must be operating to access the register. A designation of “S” indicates that supervisor access is required: a designation of “S/U” indicates that the register can be programmed to the desired privilege level.

Table D-2 GPT Address Map

Access	Address	15	8	7	0
S	\$YFF900	GPT MODULE CONFIGURATION (GPTMCR)			
S	\$YFF902	(RESERVED FOR TEST)			
S	\$YFF904	INTERRUPT CONFIGURATION (ICR)			
S/U	\$YFF906	PGP DATA DIRECTION (DDRGP)		PGP DATA (PORTGP)	
S/U	\$YFF908	OC1 ACTION MASK (OC1M)		OC1 ACTION DATA (OC1D)	
S/U	\$YFF90A	TIMER COUNTER (TCNT)			
S/U	\$YFF90C	PA CONTROL (PACTL)		PA COUNTER (PACNT)	
S/U	\$YFF90E	INPUT CAPTURE 1 (TIC1)			
S/U	\$YFF910	INPUT CAPTURE 2 (TIC2)			
S/U	\$YFF912	INPUT CAPTURE 3 (TIC3)			
S/U	\$YFF914	OUTPUT COMPARE 1 (TOC1)			
S/U	\$YFF916	OUTPUT COMPARE 2 (TOC2)			
S/U	\$YFF918	OUTPUT COMPARE 3 (TOC3)			
S/U	\$YFF91A	OUTPUT COMPARE 4 (TOC4)			
S/U	\$YFF91C	INPUT CAPTURE 4/OUTPUT COMPARE 5 (TI4/O5)			
S/U	\$YFF91E	TIMER CONTROL 1 (TCTL1)		TIMER CONTROL 2 (TCTL2)	
S/U	\$YFF920	TIMER MASK 1 (TMSK1)		TIMER MASK 2 (TMSK2)	
S/U	\$YFF922	TIMER FLAG 1 (TFLG1)		TIMER FLAG 2 (TFLG2)	
S/U	\$YFF924	FORCE COMPARE (CFORC)		PWM CONTROL C (PWMC)	
S/U	\$YFF926	PWM CONTROL A (PWMA)		PWM CONTROL B (PWMB)	
S/U	\$YFF928	PWM COUNT (PWMCNT)			
S/U	\$YFF92A	PWMA BUFFER (PWMBUFA)		PWMB BUFFER (PWMBUFB)	
S/U	\$YFF92C	GPT PRESCALER (PRESCL)			
	\$YFF92E – \$YFF93F	NOT USED			

Y = M111, where M is the logic state of the module mapping (MM) bit in the SIMCR.

D.2.1 GPTMCR — GPT Module Configuration Register

\$YFF900

15	14	13	12	11	10	9	8	7	6	5	4	3	0
STOP	FRZ1	FRZ0	STOPP	INCP	0	0	0	SUPV	0	0	0	IARB	

RESET:

0	0	0	0	0	0	0	0	1	0	0	0	0	0	0	0
---	---	---	---	---	---	---	---	---	---	---	---	---	---	---	---

GPTMCR bits control freeze, low-power stop, and single-step modes.

STOP — Stop Clocks

- 0 = Internal clocks not shut down
- 1 = Internal clocks shut down

FRZ[1:0] — FREEZE Response

FRZ1 is not used; FRZ0 encoding determines response to the IMB FREEZE signal.
 0 = Ignore IMB FREEZE signal
 1 = Freeze the current state of the GPT

STOPP — Stop Prescaler

0 = Normal operation
 1 = Stop prescaler and pulse accumulator from incrementing. Ignore changes to input pins.

INCP — Increment Prescaler

0 = Has no meaning
 1 = If STOPP is asserted, increment prescaler once and clock input synchronizers once.

SUPV — Supervisor/Unrestricted Data Space

0 = Registers with access controlled by the SUPV bit are accessible from either the user or supervisor privilege level.
 1 = Registers with access controlled by the SUPV bit are restricted to supervisor access only.

IARB[3:0] — Interrupt Arbitration

Each module that generates interrupts must have an IARB value. IARB values are used to arbitrate between interrupt requests of the same priority.

D.2.2 GPTMTR — GPT Module Test Register (Reserved) \$YFF902

This address is currently unused and returns zeros when read. It is reserved for GPT factory test.

D.2.3 ICR — GPT Interrupt Configuration Register \$YFF904

	15		12	11	10		8	7		4	3	2	1	0
	IPA			0	IPL			IVBA			0	0	0	0
RESET:	0	0	0	0	0	0	0	0	0	0	0	0	0	0

ICR fields determine internal and external interrupt priority, and provide the upper nibble of the interrupt vector number supplied to the CPU when an interrupt is acknowledged.

IPA — Interrupt Priority Adjust

Specifies which of the 11 internal GPT interrupt sources is assigned highest priority.

IPL — Interrupt Priority Level

Specifies the priority level of GPT interrupt requests.

IVBA — Interrupt Vector Base Address

Contains the most significant nibble of interrupt vector numbers supplied by the GPT.

D.2.4 DDRGP — Port GP Data Direction Register **\$YFF906**
PORTGP — Port GP Data Register **\$YFF907**

15		8	7		0
DDRGP			PORTGP		
RESET:					
0	0	0	0	0	0

When GPT pins are used as an 8-bit port, DDRGP determines whether pins are input or output and PORTGP holds the 8-bit data.

DDRGP[7:0] — Parallel Data Direction Register
 0 = Input only
 1 = Output

PORTGP[7:0] — Parallel Data Register

D.2.5 OC1M — OC1 Action Mask Register **\$YFF908**
OC1D — OC1 Action Data Register **\$YFF909**

15		11	10	9	8	7		3	2	1	0	
OC1M				0	0	0	OC1D			0	0	0
RESET:												
0	0	0	0	0	0	0	0	0	0	0	0	

All OC outputs can be controlled by the action of OC1. OC1M contains a mask that determines which pins are affected. OC1D determines what outputs are affected.

OC1M[5:1] — OC1 Mask
 0 = Corresponding output compare pin is not affected by OC1 compare.
 1 = Corresponding output compare pin is affected by OC1 compare.
 OC1M[5:1] correspond to OC[5:1].

OC1D[5:1] — OC1 Data
 0 = If OC1 mask bit is set, clear corresponding output compare pin on OC1 match.
 1 = If OC1 mask bit is set, set corresponding output compare pin on OC1 match.
 OC1D[5:1] correspond to OC[5:1].

D.2.6 TCNT — Timer Counter Register **\$YFF90A**

TCNT is the 16-bit free-running counter associated with the input capture, output compare, and pulse accumulator functions of the GPT module.

D.2.7 PACTL — Pulse Accumulator Control Register

\$YFF90C

PACNT — Pulse Accumulator Counter

\$YFF90D

15	14	13	12	11	10	9	8	7								0
PAIS	PAEN	PAMOD	PEDGE	PCLKS	I4/O5	PACLK		PACNT								
RESET:																
U	0	0	0	U	0	0	0	0	0	0	0	0	0	0	0	

PACTL enables the pulse accumulator and selects either event counting or gated mode. In event counting mode, PACNT is incremented each time an event occurs. In gated mode, it is incremented by an internal clock.

PAIS — PAI Pin State (Read Only)

PAEN — Pulse Accumulator Enable
 0 = Pulse accumulator disabled
 1 = Pulse accumulator enabled

PAMOD — Pulse Accumulator Mode
 0 = External event counting
 1 = Gated time accumulation

PEDGE — Pulse Accumulator Edge Control
 The effects of PEDGE and PAMOD are shown in the following table.

PAMOD	PEDGE	Effect
0	0	PAI Falling Edge Increments Counter
0	1	PAI Rising Edge Increments Counter
1	0	Zero on PAI Inhibits Counting
1	1	One on PAI Inhibits Counting

PCLKS — PCLK Pin State (Read Only)

I4/O5 — Input Capture 4/Output Compare 5
 0 = Output compare 5 enabled
 1 = Input capture 4 enabled

PACLK[1:0] — Pulse Accumulator Clock Select (Gated Mode)

PACLK[1:0]	Pulse Accumulator Clock Selected
00	System Clock Divided by 512
01	Same Clock Used to Increment TCNT
10	TOF Flag from TCNT
11	External Clock, PCLK

PACNT — Pulse Accumulator Counter

Eight-bit read/write counter used for external event counting or gated time accumulation.

D.2.8 TIC[1:3] — Input Capture Registers 1–3 \$YFF90E–\$YFF912

The input capture registers are 16-bit read-only registers used to latch the value of TCNT when a specified transition is detected on the corresponding input capture pin. They are reset to \$FFFF.

D.2.9 TOC[1:4] — Output Compare Registers 1–4 \$YFF914–\$YFF91A

The 16-bit read/write output compare registers can be used as output waveform controls or as elapsed time indicators. For output compare functions, they are written to a desired match value and compared against TCNT to control specified pin actions. They are reset to \$FFFF.

D.2.10 TI4/O5 — Input Capture 4/Output Compare 5 Register \$YFF91C

This register serves either as input capture register 4 or output compare register 5, depending on the state of I4/O5 in PACTL.

D.2.11 TCTL1/TCTL2 — Timer Control Registers 1 and 2 \$YFF91E

15	14	13	12	11	10	9	8	7	6	5	4	3	2	1	0
OM5	OL5	OM4	OL4	OM3	OL3	OM2	OL2	EDGE4		EDGE3		EDGE2		EDGE1	
RESET:															
0	0	0	0	0	0	0	0	0	0	0	0	0	0	0	0

TCTL1 determines output compare mode and output logic level. TCTL2 determines the type of input capture to be performed.

OM/OL[5:2] — Output Compare Mode Bits and Output Compare Level Bits
 Each pair of bits specifies an action to be taken when output comparison is successful.

OM/OL[5:2]	Action Taken
00	Timer Disconnected from Output Logic
01	Toggle OCx Output Line
10	Clear OCx Output Line to zero
11	Set OCx Output Line to one

EDGE[4:1] — Input Capture Edge Control
 Each pair of bits configures input sensing logic for the corresponding input capture.

EDGE[4:1]	Configuration
00	Capture Disabled
01	Capture on Rising Edge Only
10	Capture on Falling Edge Only
11	Capture on Any (Rising or Falling) Edge

D.2.12 TMSK1/TMSK2 — Timer Interrupt Mask Registers 1 and 2

\$YFF920

15	14	11	10	8	7	6	5	4	3	2	0
I4/O5I	OCI			ICI		TOI	0	PAOVI	PAII	CPROUT	CPR
RESET:											
0	0	0	0	0	0	0	0	0	0	0	0

TMSK1 enables OC and IC interrupts. TMSK2 controls pulse accumulator interrupts and TCNT functions.

I4/O5I — Input Capture 4/Output Compare 5 Interrupt Enable

0 = IC4/OC5 interrupt disabled

1 = IC4/OC5 interrupt requested when I4/O5F flag in TFLG1 is set

OCI[4:1] — Output Compare Interrupt Enable

0 = OC interrupt disabled

1 = OC interrupt requested when OC flag set

OCI[4:1] correspond to OC[4:1].

ICI[3:1] — Input Capture Interrupt Enable

0 = IC interrupt disabled

1 = IC interrupt requested when IC flag set

ICI[3:1] correspond to IC[3:1].

TOI — Timer Overflow Interrupt Enable

0 = Timer overflow interrupt disabled

1 = Interrupt requested when TOF flag is set

PAOVI — Pulse Accumulator Overflow Interrupt Enable

0 = Pulse accumulator overflow interrupt disabled

1 = Interrupt requested when PAOVF flag is set

PAII — Pulse Accumulator Input Interrupt Enable

0 = Pulse accumulator interrupt disabled

1 = Interrupt requested when PAIF flag is set

CPROUT — Capture/Compare Unit Clock Output Enable

0 = Normal operation for OC1 pin

1 = TCNT clock driven out OC1 pin

CPR[2:0] — Timer Prescaler/PCLK Select Field

This field selects one of seven prescaler taps or PCLK to be TCNT input.

D

D.2.13 TFLG1/TFLG2 — Timer Interrupt Flag Registers 1 and 2

\$YFF922

15	14	11	10	8	7	6	5	4	3	2	1	0
I4/O5F	OCF			ICF			TOF	0	PAOVF	PAIF	0	0
RESET:												
0	0	0	0	0	0	0	0	0	0	0	0	0

These registers show condition flags that correspond to GPT events. If the corresponding interrupt enable bit in TMSK1/TMSK2 is set, an interrupt occurs.

I4/O5F — Input Capture 4/Output Compare 5 Flag

When I4/O5 in PACTL is zero, this flag is set each time TCNT matches the TOC5 value in TI4/O5. When I4/O5 in PACTL is one, the flag is set each time a selected edge is detected at the I4/O5 pin.

OCF[4:1] — Output Compare Flags

An output compare flag is set each time TCNT matches the corresponding TOC register. OCF[4:1] correspond to OC[4:1].

ICF[3:1] — Input Capture Flags

A flag is set each time a selected edge is detected at the corresponding input capture pin. ICF[3:1] correspond to IC[3:1].

TOF — Timer Overflow Flag

This flag is set each time TCNT advances from a value of \$FFFF to \$0000.

PAOVF — Pulse Accumulator Overflow Flag

This flag is set each time the pulse accumulator counter advances from a value of \$FF to \$00.

PAIF — Pulse Accumulator Flag

In event counting mode, this flag is set when an active edge is detected on the PAI pin. In gated time accumulation mode, it is set at the end of the timed period.

D.2.14 CFORC — Compare Force Register

\$YFF924

PWMC — PWM Control Register C

\$YFF925

15	11	10	9	8	7	6	4	3	2	1	0	
FOC			0	FPWMA	FPWMB	PPROUT	PPR		SFA	SFB	F1A	F1B
RESET:												
0	0	0	0	0	0	0	0	0	0	0	0	

Setting a bit in CFORC causes a specific output on OC or PWM pins. PWMC sets PWM operating conditions.

FOC[5:1] — Force Output Compare

0 = Has no meaning.

1 = Causes pin action programmed for corresponding OC pin, but the OC flag is not set.

FOC[5:1] correspond to OC[5:1].

FPWMA — Force PWMA Value

0 = Normal PWMA operation.

1 = The value of F1A is driven out on the PWMA pin, regardless of the state of PPROUT.

FPWMB — Force PWMB Value

0 = Normal PWMB operation.

1 = The value of F1B is driven out on the PWMB pin.

PPROUT — PWM Clock Output Enable

0 = Normal PWM operation on PWMA.

1 = TCNT clock driven out PWMA pin.

PPR[2:0] — PWM Prescaler/PCLK Select

This field selects one of seven prescaler taps or PCLK to be PWMCNT input.

PPR[2:0]	System Clock Divide-by Factor
000	2
001	4
010	8
011	16
100	32
101	64
110	128
111	PCLK

D

SFA — PWMA Slow/Fast Select

0 = PWMA period is 256 PWMCNT increments long.

1 = PWMA period is 32768 PWMCNT increments long.

SFB — PWMB Slow/Fast Select

0 = PWMB period is 256 PWMCNT increments long.

1 = PWMB period is 32768 PWMCNT increments long.

The following table shows a range of PWM output frequencies using a 16.78-MHz system clock and 20.97 system clock.

PPR [2:0]	Prescaler Tap		SFA/B = 0		SFA/B = 1	
	16.78 MHz	20.97 MHz	16.78 MHz	20.97 MHz	16.78 MHz	20.97 MHz
000	Div 2 = 8.39 MHz	Div 2 = 10.5 MHz	32.8 kHz	41 kHz	256 Hz	320 Hz
001	Div 4 = 4.19 MHz	Div 4 = 5.25 MHz	16.4 kHz	20.5 kHz	128 Hz	160 Hz
010	Div 8 = 2.10 MHz	Div 8 = 2.62 MHz	8.19 kHz	10.2 kHz	64.0 Hz	80.0 Hz
011	Div 16 = 1.05 MHz	Div 16 = 1.31 MHz	4.09 kHz	5.15 kHz	32.0 Hz	40.0 Hz
100	Div 32 = 524 kHz	Div 32 = 655 kHz	2.05 kHz	2.56 kHz	16.0 Hz	20.0 Hz
101	Div 64 = 262 kHz	Div 64 = 328 kHz	1.02 kHz	1.28 kHz	8.0 Hz	10.0 Hz
110	Div 128 = 131 kHz	Div 128 = 164 kHz	512 Hz	641 Hz	4.0 Hz	5.0 Hz
111	PCLK	PCLK	PCLK/256	PCLK/256	PCLK/32768	PCLK/32768

F1A — Force Logic Level One on PWMA

0 = Force logic level zero output on PWMA pin.

1 = Force logic level one output on PWMA pin.

F1B — Force Logic Level One on PWMB
 0 = Force logic level zero output on PWMB pin.
 1 = Force logic level one output on PWMB pin.

D.2.15 PWMA/PWMB — PWM Registers A/B \$YFF926, \$YFF927

The value in these registers determines pulse width of the corresponding PWM output. A value of \$00 corresponds to continuously low output; a value of \$80 to 50% duty cycle. Maximum value (\$FF) selects an output that is high for 255/256 of the period. Writes to these registers are buffered by PWMBUFA and PWMBUFB.

D.2.16 PWMCNT — PWM Count Register \$YFF928

PWMCNT is the 16-bit free-running counter used for GPT PWM functions.

D.2.17 PWMBUFA — PWM Buffer Register A \$YFF92A
PWMBUFB — PWM Buffer Register B \$YFF92B

To prevent glitches when PWM duty cycle is changed, the contents of PWMA and PWMB are transferred to these read-only registers at the end of each duty cycle. Reset state is \$0000.

D.2.18 PRESCL — GPT Prescaler \$YFF92C

The 9-bit prescaler value can be read from bits [8:0] at this address. Bits [15:9] always read as zeros. Reset state is \$0000.

D.3 System Integration Module

Table D-3 displays the SIM address map. The column labeled “Access” indicates the privilege level at which the CPU must be operating to access the register. A designation of “S” indicates that supervisor access is required. A designation of “S/U” indicates that the register can be programmed to the desired privilege level.

Table D-3 SIM Address Map

Access	Address	15	8	7	0
S	\$YFFA00	SIM CONFIGURATION (SIMCR)			
S	\$YFFA02	FACTORY TEST (SIMTR)			
S	\$YFFA04	CLOCK SYNTHESIZER CONTROL (SYNCR)			
S	\$YFFA06	NOT USED	RESET STATUS REGISTER (RSR)		
S	\$YFFA08	MODULE TEST E (SIMTRE)			
S	\$YFFA0A	NOT USED	NOT USED		
S	\$YFFA0C	NOT USED	NOT USED		
S	\$YFFA0E	NOT USED	NOT USED		
S/U	\$YFFA10	NOT USED	PORT E DATA (PORTE0)		
S/U	\$YFFA12	NOT USED	PORT E DATA (PORTE1)		
S/U	\$YFFA14	NOT USED	PORT E DATA DIRECTION (DDRE)		
S	\$YFFA16	NOT USED	PORT E PIN ASSIGNMENT (PEPAR)		
S/U	\$YFFA18	NOT USED	PORT F DATA (PORTF0)		
S/U	\$YFFA1A	NOT USED	PORT F DATA (PORTF1)		
S/U	\$YFFA1C	NOT USED	PORT F DATA DIRECTION (DDRF)		
S	\$YFFA1E	NOT USED	PORT F PIN ASSIGNMENT (PFPAR)		
S	\$YFFA20	NOT USED	SYSTEM PROTECTION CONTROL (SYPCR)		
S	\$YFFA22	PERIODIC INTERRUPT CONTROL (PICR)			
S	\$YFFA24	PERIODIC INTERRUPT TIMING (PITR)			
S	\$YFFA26	NOT USED	SOFTWARE SERVICE (SWSR)		
S	\$YFFA28	NOT USED	NOT USED		
S	\$YFFA2A	NOT USED	NOT USED		
S	\$YFFA2C	NOT USED	NOT USED		
S	\$YFFA2E	NOT USED	NOT USED		
S	\$YFFA30	TEST MODULE MASTER SHIFT A (TSTMSRA)			
S	\$YFFA32	TEST MODULE MASTER SHIFT B (TSTMSRB)			
S	\$YFFA34	TEST MODULE SHIFT COUNT (TSTSC)			
S	\$YFFA36	TEST MODULE REPETITION COUNTER (TSTRC)			
S	\$YFFA38	TEST MODULE CONTROL (CREG)			
S/U	\$YFFA3A	TEST MODULE DISTRIBUTED REGISTER (DREG)			
	\$YFFA3C	NOT USED	NOT USED		
	\$YFFA3E	NOT USED	NOT USED		
S/U	\$YFFA40	NOT USED	PORT C DATA (PORTC)		
	\$YFFA42	NOT USED	NOT USED		
S	\$YFFA44	CHIP-SELECT PIN ASSIGNMENT (CSPAR0)			
S	\$YFFA46	CHIP-SELECT PIN ASSIGNMENT (CSPAR1)			
S	\$YFFA48	CHIP-SELECT BASE BOOT (CSBARBT)			
S	\$YFFA4A	CHIP-SELECT OPTION BOOT (CSORBT)			
S	\$YFFA4C	CHIP-SELECT BASE 0 (CSBAR0)			
S	\$YFFA4E	CHIP-SELECT OPTION 0 (CSOR0)			

Table D-3 SIM Address Map

Access	Address	15	8 7	0
S	\$YFFA50		CHIP-SELECT BASE 1 (CSBAR1)	
S	\$YFFA52		CHIP-SELECT OPTION 1 (CSOR1)	
S	\$YFFA54		CHIP-SELECT BASE 2 (CSBAR2)	
S	\$YFFA56		CHIP-SELECT OPTION 2 (CSOR2)	
S	\$YFFA58		CHIP-SELECT BASE 3 (CSBAR3)	
S	\$YFFA5A		CHIP-SELECT OPTION 3 (CSOR3)	
S	\$YFFA5C		CHIP-SELECT BASE 4 (CSBAR4)	
S	\$YFFA5E		CHIP-SELECT OPTION 4 (CSOR4)	
S	\$YFFA60		CHIP-SELECT BASE 5 (CSBAR5)	
S	\$YFFA62		CHIP-SELECT OPTION 5 (CSOR5)	
S	\$YFFA64		CHIP-SELECT BASE 6 (CSBAR6)	
S	\$YFFA66		CHIP-SELECT OPTION 6 (CSOR6)	
S	\$YFFA68		CHIP-SELECT BASE 7 (CSBAR7)	
S	\$YFFA6A		CHIP-SELECT OPTION 7 (CSOR7)	
S	\$YFFA6C		CHIP-SELECT BASE 8 (CSBAR8)	
S	\$YFFA6E		CHIP-SELECT OPTION 8 (CSOR8)	
S	\$YFFA70		CHIP-SELECT BASE 9 (CSBAR9)	
S	\$YFFA72		CHIP-SELECT OPTION 9 (CSOR9)	
S	\$YFFA74		CHIP-SELECT BASE 10 (CSBAR10)	
S	\$YFFA76		CHIP-SELECT OPTION 10 (CSOR10)	
	\$YFFA78	NOT USED		NOT USED
	\$YFFA7A	NOT USED		NOT USED
	\$YFFA7C	NOT USED		NOT USED
	\$YFFA7E	NOT USED		NOT USED

Y = M111, where M is the logic state of the module mapping (MM) bit in the SIMCR

D.3.1 SIMCR — Module Configuration Register

\$YFFA00

15	14	13	12	11	10	9	8	7	6	5	4	3	0	
EXOFF	FRZSW	FRZBM	0	SLVEN	0	SHEN	SUPV	MM	0	0			IARB	
RESET:														
0	0	0	0	DATA11	0	0	0	1	1	0	0	1	1	1

SIMCR controls system configuration. SIMCR can be read or written at any time, except for the module mapping (MM) bit, which can only be written once.

EXOFF — External Clock Off

- 0 = The CLKOUT pin is driven from an internal clock source.
- 1 = The CLKOUT pin is placed in a high-impedance state.

FRZSW — Freeze Software Enable

- 0 = When FREEZE is asserted, the software watchdog and periodic interrupt timer counters continue to run.
- 1 = When FREEZE is asserted, the software watchdog and periodic interrupt timer counters are disabled, preventing interrupts during software debug.

FRZBM — Freeze Bus Monitor Enable

- 0 = When FREEZE is asserted, the bus monitor continues to operate.
- 1 = When FREEZE is asserted, the bus monitor is disabled.

SLVEN — Factory Test Mode Enabled

- 0 = IMB is not available to an external master.
- 1 = An external bus master has direct access to the IMB.

SHEN[1:0] — Show Cycle Enable

This field determines what the EBI does with the external bus during internal transfer operations.

SUPV — Supervisor/Unrestricted Data Space

- The SUPV bit places the SIM global registers in either supervisor or user data space.
- 0 = Registers with access controlled by the SUPV bit are accessible from either the user or supervisor privilege level.
- 1 = Registers with access controlled by the SUPV bit are restricted to supervisor access only.

MM — Module Mapping

- 0 = Internal modules are addressed from \$7FF000 – \$7FFFFFFF.
- 1 = Internal modules are addressed from \$FFF000 – \$FFFFFFF.

IARB[3:0] — Interrupt Arbitration Field

Determines SIM interrupt arbitration priority. The reset value is \$F (highest priority), to prevent SIM interrupts from being discarded during initialization.

D.3.2 SIMTR — System Integration Test Register \$YFFA02

SIMTR is used for factory test only.

D.3.3 SYNCR — Clock Synthesizer Control Register \$YFFA04

15	14	13					8	7	6	5	4	3	2	1	0	
W	X	Y				EDIV	0	0	SLIMP	SLOCK	RSTEN	STSIM	STEXT			
RESET:																
0	0	1	1	1	1	1	1	0	0	0	U	U	0	0	0	

SYNCR determines system clock operating frequency and mode of operation. Clock frequency is determined by SYNCR bit settings as follows:

W — Frequency Control (VCO)

- 0 = Base VCO frequency
- 1 = VCO frequency multiplied by four

X — Frequency Control Bit (Prescale)

- 0 = VCO frequency divided by four (base system clock frequency)
- 1 = VCO frequency divided by two (system clock frequency doubles)

Y[5:0] — Frequency Control (Counter)

The Y field is the initial value for the modulus 64 down counter in the synthesizer feedback loop. Values range from 0 to 63.

EDIV — ECLK Divide Rate

- 0 = ECLK is system clock divided by 8
- 1 = ECLK is system clock divided by 16

SLIMP — Limp Mode

- 0 = External crystal is VCO reference
- 1 = Loss of crystal reference

SLOCK — Synthesizer Lock

- 0 = VCO is enabled, but has not locked.
- 1 = VCO has locked on the desired frequency or system clock is external.

RSTEN — Reset Enable

- 0 = Loss of reference causes the MCU to operate in limp mode.
- 1 = Loss of reference causes system reset.

STSIM — Stop Mode System Integration Clock

- 0 = SIM clock driven by an external source and VCO off during low-power stop.
- 1 = SIM clock driven by VCO during low-power stop.

STEXT — Stop Mode External Clock

- 0 = CLKOUT held low during low-power stop.
- 1 = CLKOUT driven from SIM clock during low-power stop.

D.3.4 RSR — Reset Status Register

\$YFFA07

15	8	7	6	5	4	3	2	1	0		
NOT USED				EXT	POW	SW	HLT	0	LOC	SYS	TST

RSR contains a status bit for each reset source in the MCU. RSR is updated when the MCU comes out of reset. A set bit indicates what type of reset occurred. If multiple sources assert reset signals at the same time, more than one bit in RSR may be set. This register can be read at any time; a write has no effect.

EXT — External Reset

Reset caused by an external signal.

POW — Power-Up Reset

Reset caused by the power-up reset circuit.

SW — Software Watchdog Reset

Reset caused by the software watchdog circuit.

HLT — Halt Monitor Reset

Reset caused by the halt monitor.

LOC — Loss of Clock Reset

Reset caused by loss of clock frequency reference.

SYS — System Reset

Reset caused by a RESET instruction.

TST — Test Submodule Reset

Reset caused by the test submodule. Used during system test only.

D.3.5 SIMTRE — System Integration Test Register (ECLK)

\$YFFFA08

Register is used for factory test only.

D.3.6 PORTE0/PORTE1 — Port E Data Register

\$YFFFA11, \$YFFFA13

15	8	7	6	5	4	3	2	1	0
NOT USED		PE7	PE6	PE5	PE4	PE3	PE2	PE1	PE0
RESET:									
		U	U	U	U	U	U	U	U

PORTE is an internal data latch that can be accessed at two locations. PORTE can be read or written at any time. If a pin in I/O port E is configured as an output, the corresponding bit value is driven out on the pin. When a pin is configured for output, a read of PORTE returns the latched bit value; when a pin is configured for input, a read returns the pin logic level.

D.3.7 DDRE — Port E Data Direction Register

\$YFFFA15

15	8	7	6	5	4	3	2	1	0
NOT USED		DDE7	DDE6	DDE5	DDE4	DDE3	DDE2	DDE1	DDE0
RESET:									
		0	0	0	0	0	0	0	0

Bits in this register control the direction of the port E pin drivers when pins are configured for I/O. Setting a bit configures the corresponding pin as an output; clearing a bit configures the corresponding pin as an input. This register can be read or written at any time.

D.3.8 PEPAR — Port E Pin Assignment Register

\$YFFFA17

15	8	7	6	5	4	3	2	1	0
NOT USED		PEPA7	PEPA6	PEPA5	PEPA4	PEPA3	PEPA2	PEPA1	PEPA0
RESET:									
		DATA8	DATA8	DATA8	DATA8	DATA8	DATA8	DATA8	DATA8

Bits in this register determine the function of port E pins. Setting a bit assigns the corresponding pin to a bus control signal; clearing a bit assigns the pin to I/O port E.

Table D-4 Port E Pin Assignments

PEPAR Bit	Port E Signal	Bus Control Signal
PEPA7	PE7	SIZ1
PEPA6	PE6	SIZ0
PEPA5	PE5	\overline{AS}
PEPA4	PE4	DS
PEPA3	PE3	RMC
PEPA2	PE2	\overline{AVEC}
PEPA1	PE1	DSACK1
PEPA0	PE0	DSACK0

D.3.9 PORTF0/PORTF1 — Port F Data Register

\$YFFA19, \$YFFA1B

15	8	7	6	5	4	3	2	1	0
NOT USED		PF7	PF6	PF5	PF4	PF3	PF2	PF1	PF0
RESET:		U	U	U	U	U	U	U	U

PORTF is an internal data latch that can be accessed at two locations. It can be read or written at any time. If a pin in I/O port F is configured as an output, the corresponding bit value is driven out on the pin. When a pin is configured for output, a read of PORTF returns the latched bit value; when a pin is configured for input, a read returns the pin logic level.

D.3.10 DDRF — Port F Data Direction Register

\$YFFA1D

15	8	7	6	5	4	3	2	1	0
NOT USED		DDF7	DDF6	DDF5	DDF4	DDF3	DDF2	DDF1	DDF0
RESET:		0	0	0	0	0	0	0	0

Bits in this register control the direction of the port F pin drivers when pins are configured for I/O. Setting a bit configures the corresponding pin as an output; clearing a bit configures the corresponding pin as an input. This register can be read or written at any time.

D.3.11 PFPAR — Port F Pin Assignment Register

\$YFFA1F

15	8	7	6	5	4	3	2	1	0
NOT USED		PFPA7	PFPA6	PFPA5	PFPA4	PFPA3	PFPA2	PFPA1	PFPA0
RESET:		DATA9	DATA9	DATA9	DATA9	DATA9	DATA9	DATA9	DATA9

Bits in this register determine the function of port F pins. Setting a bit assigns the corresponding pin to a control signal; clearing a bit assigns the pin to port F.

Table D-5 Port F Pin Assignments

PFPA Field	Port F Signal	Control Signal
PFPA7	PF7	$\overline{\text{IRQ7}}$
PFPA6	PF6	$\overline{\text{IRQ6}}$
PFPA5	PF5	$\overline{\text{IRQ5}}$
PFPA4	PF4	$\overline{\text{IRQ4}}$
PFPA3	PF3	$\overline{\text{IRQ3}}$
PFPA2	PF2	$\overline{\text{IRQ2}}$
PFPA1	PF1	$\overline{\text{IRQ1}}$
PFPA0	PF0	MODCLK

D.3.12 SYPCR — System Protection Control Register

\$YFFA21

15	8	7	6	5	4	3	2	1	0
NOT USED		SWE	SWP	SWT		HME	BME	BMT	
RESET:									
		1	$\overline{\text{MODCLK}}$	0	0	0	0	0	0

SYPCR controls system monitor functions, software watchdog clock prescaling, and bus monitor timing. This register can be written once following power-on or reset.

SWE — Software Watchdog Enable
 0 = Software watchdog disabled
 1 = Software watchdog enabled

SWP — Software Watchdog Prescale
 0 = Software watchdog clock not prescaled
 1 = Software watchdog clock prescaled by 512

SWT[1:0] — Software Watchdog Timing
 This field selects software watchdog time-out period.

Table D-6 Software Watchdog Ratio

SWP	SWT	Ratio
0	00	2^9
0	01	2^{11}
0	10	2^{13}
0	11	2^{15}
1	00	2^{18}
1	01	2^{20}
1	10	2^{22}
1	11	2^{24}

HME — Halt Monitor Enable
 0 = Disable halt monitor function
 1 = Enable halt monitor function

BME — Bus Monitor External Enable

0 = Disable bus monitor function for an internal to external bus cycle.

1 = Enable bus monitor function for an internal to external bus cycle.

BMT[1:0] — Bus Monitor Timing

This field selects bus monitor time-out period.

Table D-7 Bus Monitor Period

BMT	Bus Monitor Time-out Period
00	64 System Clocks
01	32 System Clocks
10	16 System Clocks
11	8 System Clocks

D.3.13 PICR — Periodic Interrupt Control Register

\$YFFA22

15	14	13	12	11	10	8	7	0						
0	0	0	0	0	PIRQL	PIV								
RESET:														
0	0	0	0	0	0	0	0	0	0	0	1	1	1	1

Contains information concerning periodic interrupt priority and vectoring. PICR[10:0] can be read or written at any time. PICR[15:11] are unimplemented and always return zero.

PIRQL[2:0] — Periodic Interrupt Request Level

This field determines the priority of periodic interrupt requests.

PIV[7:0] — Periodic Interrupt Vector

The bits of this field contain the periodic interrupt vector number supplied by the SIM when the CPU acknowledges an interrupt request.

D.3.14 PITR — Periodic Interrupt Timer Register

\$YFFA24

15	14	13	12	11	10	9	8	7	0					
0	0	0	0	0	0	0	PTP	PITM						
RESET:														
0	0	0	0	0	0	0	MODCLK	0	0	0	0	0	0	0

Contains the count value for the periodic timer. This register can be read or written at any time.

PTP — Periodic Timer Prescaler Control

0 = Periodic timer clock not prescaled

1 = Periodic timer clock prescaled by a value of 512

PITM[7:0] — Periodic Interrupt Timing Modulus

This is the 8-bit timing modulus used to determine periodic interrupt rate. Use the following expression to calculate timer period.

D.3.15 SWSR — Software Service Register **\$YFFA27**

15		8	7	6	5	4	3	2	1	0
NOT USED			0	0	0	0	0	0	0	0
RESET:										
			0	0	0	0	0	0	0	0

When the software watchdog is enabled, a service sequence must be written to this register within a specific interval. When read, SWSR always returns \$00. Register shown with read value.

D.3.16 TSTMSRA — Master Shift Register A **\$YFFA30**

Register is used for factory test only.

D.3.17 TSTMSRB — Master Shift Register B **\$YFFA32**

Register is used for factory test only.

D.3.18 TSTSC — Test Module Shift Count **\$YFFA34**

Register is used for factory test only.

D.3.19 TSTRC — Test Module Repetition Count **\$YFFA36**

Register is used for factory test only.

D.3.20 CREG — Test Submodule Control Register **\$YFFA38**

Register is used for factory test only.

D.3.21 DREG — Distributed Register **\$YFFA3A**

Register is used for factory test only.

D.3.22 PORTC — Port C Data Register **\$YFFA41**

15		8	7	6	5	4	3	2	1	0
NOT USED			0	PC6	PC5	PC4	PC3	PC2	PC1	PC0
RESET:										
			0	1	1	1	1	1	1	1

PORTC latches data for chip-select pins that are used for discrete output.

D.3.23 CSPAR0 — Chip Select Pin Assignment Register 0 **\$YFFA44**

15	14	13	12	11	10	9	8	7	6	5	4	3	2	1	0
0	0	CSPA0[6]	CSPA0[5]	CSPA0[4]	CSPA0[3]	CSPA0[2]	CSPA0[1]	CSPA0[0]	CSBOOT						
RESET:															
0	0	DATA2	1	DATA2	1	DATA2	1	DATA1	1	DATA1	1	DATA1	1	1	DATA0

Table D-8 CSPAR0 Pin Assignments

CSPAR0 Field	CSPAR0 Signal	Alternate Signal	Discrete Output
CSPA0[6]	$\overline{CS5}$	FC2	PC2
CSPA0[5]	$\overline{CS4}$	FC1	PC1
CSPA0[4]	$\overline{CS3}$	FC0	PC0
CSPA0[3]	$\overline{CS2}$	BGACK	—
CSPA0[2]	$\overline{CS1}$	BG	—
CSPA0[1]	$\overline{CS0}$	BR	—
\overline{CSBOOT}	\overline{CSBOOT}	—	—

Contains seven 2-bit fields, CSPA0[6:1] and \overline{CSBOOT} , that determine the functions of corresponding chip-select pins. CSPAR0[15:14] are not used. These bits always read zero; write has no effect. CSPAR0 bit 1 always reads one; writes to CSPAR0 bit 1 have no effect. The alternate functions can be enabled by data bus mode selection during reset.

D.3.24 CSPAR1 — Chip Select Pin Assignment Register 1

\$YFFA46

15	14	13	12	11	10	9	8	7	6	5	4	3	2	1	0
0	0	0	0	0	0	CSPA1[4]		CSPA1[3]		CSPA1[2]		CSPA1[1]		CSPA1[0]	
RESET:															
0	0	0	0	0	0	DATA7	1	DATA6	1	DATA5	1	DATA4	1	DATA3	1

Table D-9 CSPAR1 Pin Assignments

CSPAR1 Field	CSPAR1 Signal	Alternate Signal	Discrete Output
CSPA1[4]	$\overline{CS10}$	ADDR23	ECLK
CSPA1[3]	$\overline{CS9}$	ADDR22	PC6
CSPA1[2]	$\overline{CS8}$	ADDR21	PC5
CSPA1[1]	$\overline{CS7}$	ADDR20	PC4
CSPA1[0]	$\overline{CS6}$	ADDR19	PC3

Contains five 2-bit fields (CSPA1[4:0]) that determine the functions of corresponding chip-select pins. CSPAR1[15:10] are not used. These bits always read zero; write has no effect. The CSPAR1 pin assignments table shows alternate functions that can be enabled by data bus mode selection during reset.

Table D-10 CSPAR0 and CSPAR1 Pin Assignment Field Encoding

Bit Field	Description
00	Discrete Output*
01	Alternate Function*
10	Chip Select (8-Bit Port)
11	Chip Select (16-Bit Port)

*Does not apply to the \overline{CSBOOT} field

D.3.25 CSBARBT — Chip Select Base Address Register Boot ROM \$YFFA48
CSBAR[0:10] — Chip Select Base Address Registers \$YFFA4C–\$YFFA74

15	14	13	12	11	10	9	8	7	6	5	4	3	2	0
ADDR 23	ADDR 22	ADDR 21	ADDR 20	ADDR 19	ADDR 18	ADDR 17	ADDR 16	ADDR 15	ADDR 14	ADDR 13	ADDR 12	ADDR 11	BLKSZ	
RESET:														
0	0	0	0	0	0	0	0	0	0	0	0	0	0	0

Each chip-select pin has an associated base address register. A base address is the lowest address in the block of addresses enabled by a chip select. CSBARBT contains the base address for selection of a bootstrap peripheral memory device. Bit and field definition for CSBARBT and CSBAR[0:10] are the same, but reset block sizes differ.

ADDR[23:11] — Base Address

This field sets the starting address of a particular address space.

BLKSZ — Block Size

This field determines the size of the block above the base address that is enabled by the chip select.

D

Table D-11 Block Size Encoding

BLKSZ[2:0]	Block Size	Address Lines Compared
000	2 K	ADDR[23:11]
001	8 K	ADDR[23:13]
010	16 K	ADDR[23:14]
011	64 K	ADDR[23:16]
100	128 K	ADDR[23:17]
101	256 K	ADDR[23:18]
110	512 K	ADDR[23:19]
111	1 M	ADDR[23:20]

D.3.26 CSORBT — Chip Select Option Register Boot ROM \$YFFA4A
CSOR[0:10] — Chip Select Option Registers \$YFFA4E–\$YFFA76

15	14	13	12	11	10	9	6	5	4	3	1	0
MODE	BYTE	R/W	STRB	DSACK			SPACE	IPL		AVEC		
RESET:												
0	0	0	0	0	0	0	0	0	0	0	0	0

Contain parameters that support bootstrap operations from peripheral memory devices. Bit and field definitions for CSORBT and CSOR[0:10] are the same.

MODE — Asynchronous Bus/Synchronous E-clock Mode

Synchronous mode cannot be used with internally generated autovectors.

- 0 = Asynchronous mode selected
- 1 = Synchronous mode selected

BYTE — Upper/Lower Byte Option

The value in this field determines whether a select signal can be asserted.

R/W — Read/Write

This field causes a chip select to be asserted only for a read, only for a write, or for both read and write.

STRB — Address Strobe/Data Strobe

- 0 = Address strobe
- 1 = Data strobe

DSACK — Data Strobe Acknowledge

This field specifies the source of \overline{DSACK} in asynchronous bus mode and controls wait state insertion.

SPACE — Address Space Select

This field selects an address space to be used by the chip-select logic.

IPL — Interrupt Priority Level

This field determines interrupt priority level when a chip select is used for interrupt acknowledgement. It does not affect CPU interrupt recognition.

AVEC — Autovector Enable

- Do not enable autovector support when in synchronous mode.
- 0 = External interrupt vector enabled
- 1 = Autovector enabled

Table D-12 Option Register Function Summary

MODE	BYTE	R/W	STRB	DSACK	SPACE	IPL	AVEC
0 = ASYNC	00 = Disable	00 = Rsvd	0 = AS	0000 = 0 WAIT	00 = CPU SP	000 = All	0 = Off
1 = SYNC	01 = Lower	01 = Read	1 = DS	0001 = 1 WAIT	01 = User SP	001 = Priority 1	1 = On
	10 = Upper	10 = Write		0010 = 2 WAIT	10 = Supv SP	010 = Priority 2	
	11 = Both	11 = Both		0011 = 3 WAIT	11 = S/U SP	011 = Priority 3	
				0100 = 4 WAIT		100 = Priority 4	
				0101 = 5 WAIT		101 = Priority 5	
				0110 = 6 WAIT		110 = Priority 6	
				0111 = 7 WAIT		111 = Priority 7	
				1000 = 8 WAIT			
				1001 = 9 WAIT			
				1010 = 10 WAIT			
				1011 = 11 WAIT			
				1100 = 12 WAIT			
				1101 = 13 WAIT			
				1110 = F term			
				1111 = External			

D.4 Queued Serial Module

Table D-13 displays the QSM address map. The column labeled “Access” indicates the privilege level at which the CPU must be operating to access the register. A designation of “S” indicates that supervisor access is required: a designation of “S/U” indicates that the register can be programmed to the desired privilege level.

Table D-13 QSM Address Map

Access	Address	15	8	7	0
S	\$YFFC00	QSM MODULE CONFIGURATION (QSMCR)			
S	\$YFFC02	QSM TEST (QTEST)			
S	\$YFFC04	QSM INTERRUPT LEVEL (QILR)		QSM INTERRUPT VECTOR (QIVR)	
S/U	\$YFFC06	NOT USED			
S/U	\$YFFC08	SCI CONTROL 0 (SCCR0)			
S/U	\$YFFC0A	SCI CONTROL 1 (SCCR1)			
S/U	\$YFFC0C	SCI STATUS (SCSR)			
S/U	\$YFFC0E	SCI DATA (SCDR)			
S/U	\$YFFC10	NOT USED			
S/U	\$YFFC12	NOT USED			
S/U	\$YFFC14	NOT USED		PQS DATA (PORTQS)	
S/U	\$YFFC16	PQS PIN ASSIGNMENT (PQSPAR)		PQS DATA DIRECTION (DDRQS)	
S/U	\$YFFC18	SPI CONTROL 0 (SPCR0)			
S/U	\$YFFC1A	SPI CONTROL 1 (SPCR1)			
S/U	\$YFFC1C	SPI CONTROL 2 (SPCR2)			
S/U	\$YFFC1E	SPI CONTROL 3 (SPCR3)		SPI STATUS (SPSR)	
S/U	\$YFFC20– \$YFFCFF	NOT USED			
S/U QUEUE RAM	\$YFFD00– \$YFFD1F	RECEIVE RAM (RR[0:F])			
S/U QUEUE RAM	\$YFFD20– \$YFFD3F	TRANSMIT RAM (TR[0:F])			
S/U QUEUE RAM	\$YFFD40– \$YFFD4F	COMMAND RAM (CR[0:F])			

Y = M111, where M is the logic state of the module mapping (MM) bit in the SIMCR.

D.4.1 QSMCR — QSM Configuration Register

\$YFFC00

15	14	13	12	11	10	9	8	7	6	5	4	3	0
STOP	FRZ1	FRZ0	0	0	0	0	0	SUPV	0	0	0	IARB	
RESET:													
0	0	0	0	0	0	0	0	1	0	0	0	0	0

QSMCR bits enable stop and freeze modes, and determine the arbitration priority of QSM interrupt requests.

STOP — Stop Enable

- 0 = Normal QSM clock operation
- 1 = QSM clock operation stopped

When STOP is set, the QSM enters low-power stop mode. System clock input to the module is disabled. While STOP is asserted, only QSMCR reads are guaranteed to be

valid, but writes to QSPI RAM or any register are guaranteed valid. STOP is set during reset. The SCI receiver and transmitter must be disabled before STOP is set. To stop the QSPI, set the HALT bit in SPCR3, wait until the HALTA flag is set, then set STOP.

FRZ[1:0] — Freeze Control

- 0 = Ignore the FREEZE signal on the IMB
- 1 = Halt the QSPI (on a transfer boundary)

FRZ1 determines what action is taken by the QSPI when the FREEZE signal of the IMB is asserted. FREEZE is asserted whenever the CPU enters background mode. FRZ0 is reserved for future use.

SUPV — Supervisor/Unrestricted

- 0 = Supervisor access
- 1 = User access

IARB — Interrupt Arbitration

Each module that generates interrupts must have an IARB value. IARB values are used to arbitrate between interrupt requests of the same priority.

D.4.2 QTEST — QSM Test Register \$YFFC02

Used for factory test only.

D.4.3 QILR — QSM Interrupt Level Register \$YFFC04

QIVR — QSM Interrupt Vector Register \$YFFC05

15	14	13		11	10		8	7					0			
0	0	ILQSPI			ILSCI			INTV								
RESET:																
0	0	0	0	0	0	0	0	0	0	0	0	0	1	1	1	1

The values of the ILQSPI and ILSCI fields in QILR determine the priority of QSPI and SCI interrupt requests. QIVR determines the value of the interrupt vector number the QSM supplies when it responds to an interrupt acknowledge cycle. At reset, QIVR is initialized to vector number \$0F, the uninitialized interrupt vector number. To use interrupt-driven serial communication, a user-defined vector number must be written to QIVR.

ILQSPI — Interrupt Level for QSPI

When an interrupt request is made, ILQSPI value determines which of the interrupt request signals is asserted; when a request is acknowledged, the QSM compares this value to a mask value supplied by the CPU32 to determine whether to respond. ILQSPI must have a value in the range \$0 (lowest priority) to \$7 (highest priority).

ILSCI — Interrupt Level for SCI

When an interrupt request is made, ILSCI value determines which of the interrupt request signals is asserted. When a request is acknowledged, the QSM compares this value to a mask value supplied by the CPU32 to determine whether to respond. The field must have a value in the range \$0 (lowest priority) to \$7 (highest priority).

If ILQSPI and ILSCI have the same nonzero value, and both submodules simultaneously request interrupt service, the QSPI has priority.

INTV[7:0] — Interrupt Vector Number

The values of INTV[7:1] are the same for both QSPI and SCI interrupt requests; the value of INTV0 used during an interrupt acknowledge cycle is supplied by the QSM. INTV0 is at logic level zero during an SCI interrupt and at logic level one during a QSPI interrupt. A write to INTV0 has no effect. Reads of INTV0 return a value of one.

D.4.4 SCCR0 — SCI Control Register 0

\$YFFC08

15	14	13	12													0
0	0	0	SCBR													

RESET:

0 0 0 0 0 0 0 0 0 0 0 0 0 0 1 0 0

SCCR0 contains the SCI baud rate selection field. Baud rate must be set before the SCI is enabled. The CPU32 can read and write SCCR0 at any time. Changing the value of SCCR0 bits during a transfer operation can disrupt operation.

SCBR — SCI Baud Rate

SCI baud rate is programmed by writing a 13-bit value to this field. Writing a value of zero to SCBR disables the baud rate generator. Baud clock rate is calculated as follows:

D

D.4.5 SCCR1 — SCI Control Register 1

\$YFFC0A

15	14	13	12	11	10	9	8	7	6	5	4	3	2	1	0
0	LOOPS	WOMS	ILT	PT	PE	M	WAKE	TIE	TCIE	RIE	ILIE	TE	RE	RWU	SBK

RESET:

0 0 0 0 0 0 0 0 0 0 0 0 0 0 0 0

SCCR1 contains SCI configuration parameters, including transmitter and receiver enable bits, interrupt enable bits, and operating mode enable bits. The CPU can read and write SCCR0 at any time. The SCI can modify the RWU bit under certain circumstances. Changing the value of SCCR1 bits during a transfer operation can disrupt operation.

LOOPS — Loop Mode

- 0 = Normal SCI operation, no looping, feedback path disabled
- 1 = Test SCI operation, looping, feedback path enabled

WOMS — Wired-OR Mode for SCI Pins

- 0 = If configured as an output, TXD is a normal CMOS output.
- 1 = If configured as an output, TXD is an open-drain output.

ILT — Idle-Line Detect Type

- 0 = Short idle-line detect (start count on first one)
- 1 = Long idle-line detect (start count on first one after stop bit(s))

- PT — Parity Type
 - 0 = Even parity
 - 1 = Odd parity

- PE — Parity Enable
 - 0 = SCI parity disabled
 - 1 = SCI parity enabled

- M — Mode Select
 - 0 = 10-bit SCI frame
 - 1 = 11-bit SCI frame

- WAKE — Wakeup by Address Mark
 - 0 = SCI receiver awakened by idle-line detection
 - 1 = SCI receiver awakened by address mark (last bit set)

- TIE — Transmit Interrupt Enable
 - 0 = SCI TDRE interrupts inhibited
 - 1 = SCI TDRE interrupts enabled

- TCIE — Transmit Complete Interrupt Enable
 - 0 = SCI TC interrupts inhibited
 - 1 = SCI TC interrupts enabled

- RIE — Receiver Interrupt Enable
 - 0 = SCI RDRF and OR interrupts inhibited
 - 1 = SCI RDRF and OR interrupts enabled

- ILIE — Idle-Line Interrupt Enable
 - 0 = SCI IDLE interrupts inhibited
 - 1 = SCI IDLE interrupts enabled

- TE — Transmitter Enable
 - 0 = SCI transmitter disabled (TXD pin can be used as I/O)
 - 1 = SCI transmitter enabled (TXD pin dedicated to SCI transmitter)

- RE — Receiver Enable
 - 0 = SCI receiver disabled (status bits inhibited)
 - 1 = SCI receiver enabled

- RWU — Receiver Wakeup
 - 0 = Normal receiver operation (received data recognized)
 - 1 = Wakeup mode enabled (received data ignored until awakened)

- SBK — Send Break
 - 0 = Normal operation
 - 1 = Break frame(s) transmitted after completion of current frame

D.4.6 SCSR — SCI Status Register

\$YFFC0C

15	9	8	7	6	5	4	3	2	1	0
NOT USED		TDRE	TC	RDRF	RAF	IDLE	OR	NF	FE	PF
RESET:										
		1	1	0	0	0	0	0	0	0

SCSR contains flags that show SCI operating conditions. These flags are cleared either by SCI hardware or by a CPU32 read/write sequence. The sequence consists of reading SCSR, then reading or writing SCDR.

If an internal SCI signal for setting a status bit comes after the CPU32 has read the asserted status bits, but before the CPU has written or read SCDR, the newly set status bit is not cleared. SCSR must be read again with the bit set and SCDR must be written or read before the status bit is cleared.

A long-word read can consecutively access both SCSR and SCDR. This action clears receive status flag bits that were set at the time of the read, but does not clear TDRE or TC flags. Reading either byte of SCSR causes all 16 bits to be accessed, and any status bit already set in either byte are cleared on a subsequent read or write of register SCDR.

D

TDRE — Transmit Data Register Empty
 0 = Register TDR still contains data to be sent to the transmit serial shifter.
 1 = A new character can now be written to register TDR.

TC — Transmit Complete
 0 = SCI transmitter is busy.
 1 = SCI transmitter is idle.

RDRF — Receive Data Register Full
 0 = Register RDR is empty or contains previously read data.
 1 = Register RDR contains new data.

RAF — Receiver Active
 0 = SCI receiver is idle.
 1 = SCI receiver is busy.

IDLE — Idle-Line Detected
 0 = SCI receiver did not detect an idle-line condition.
 1 = SCI receiver detected an idle-line condition.

OR — Overrun Error
 0 = RDRF is cleared before new data arrives.
 1 = RDRF is not cleared before new data arrives.

NF — Noise Error Flag
 0 = No noise detected on the received data
 1 = Noise occurred on the received data.

FE — Framing Error
 0 = No framing error on the received data
 1 = Framing error or break occurred on the received data.

PF — Parity Error
 0 = No parity error on the received data
 1 = Parity error occurred on the received data.

D.4.7 SCDR — SCI Data Register \$YFFC0E

15	14	13	12	11	10	9	8	7	6	5	4	3	2	1	0
0	0	0	0	0	0	0	R8/T8	R7/T7	R6/T6	R5/T5	R4/T4	R3/T3	R2/T2	R1/T1	R0/T0
RESET:															
0	0	0	0	0	0	0	0	U	U	U	U	U	U	U	U

SCDR consists of two data registers located at the same address. RDR is a read-only register that contains data received by the SCI serial interface. Data comes into the receive serial shifter and is transferred to RDR. TDR is a write-only register that contains data to be transmitted. Data is first written to TDR, then transferred to the transmit serial shifter, where additional format bits are added before transmission. R[7:0]/T[7:0] contain either the first eight data bits received when SCDR is read, or the first eight data bits to be transmitted when SCDR is written. R8/T8 are used when the SCI is configured for 9-bit operation. When the SCI is configured for 8-bit operation, R8/T8 have no meaning or effect.

D.4.8 PORTQS — Port QS Data Register \$YFFC15

15							8	7	6	5	4	3	2	1	0
NOT USED							PQS7	PQS6	PQS5	PQS4	PQS3	PQS2	PQS1	PQS0	
RESET:															
							0	0	0	0	0	0	0	0	0

PORTQS latches I/O data. Writes drive pins defined as outputs. Reads return data present on the pins. To avoid driving undefined data, first write a byte to PORTQS, then configure DDRQS.

D.4.9 PQSPAR — PORT QS Pin Assignment Register \$YFFC16
DDRQS — PORT QS Data Direction Register \$YFFC17

15	14	13	12	11	10	9	8	7	6	5	4	3	2	1	0
0	PQSPA6	PQSPA5	PQSPA4	PQSPA3	0	PQSPA1	PQSPA0	DDQS7	DDQS6	DDQS5	DDQS4	DDQS3	DDQS2	DDQS1	DDQS0
RESET:															
0	0	0	0	0	0	0	0	0	0	0	0	0	0	0	0

Clearing a bit in PQSPAR assigns the corresponding pin to general-purpose I/O; setting a bit assigns the pin to the QSPI. PQSPAR does not affect operation of the SCI.

Table D-14 PQSPAR Pin Assignments

PQSPAR Field	PQSPAR Bit	Pin Function
PQSPA0	0	PQS0
	1	MISO
PQSPA1	0	PQS1
	1	MOSI
PQSPA2	0	PQS2 ¹
	1	SCK
PQSPA3	0	PQS3
	1	PCS0/ \overline{SS}
PQSPA4	0	PQS4
	1	PCS1
PQSPA5	0	PQS5
	1	PCS2
PQSPA6	0	PQS6
	1	PCS3
PQSPA7	0	PQS7 ²
	1	TXD

1. PQS2 is a digital I/O pin unless the SPI is enabled (SPE in SPCR1 set), in which case it becomes SPI serial clock SCK.
2. PQS7 is a digital I/O pin unless the SCI transmitter is enabled (TE in SCCR1 = 1), in which case it becomes SCI serial output TXD.

DDRQS determines whether pins are inputs or outputs. Clearing a bit makes the corresponding pin an input; setting a bit makes the pin an output. DDRQS affects both QSPI function and I/O function.

Table D-15 Effect of DDRQS on PORTQS Pins

Pin	DDRQS Bit	Pin Function
PQS0	0	Digital Input
	1	Digital Output
PQS1	0	Digital Input
	1	Digital Output
PQS2	0	Digital Input
	1	Digital Output
PQS2	0	Digital Input
	1	Digital Output
PQS3	0	Digital Input
	1	Digital Output
PQS4	0	Digital Input
	1	Digital Output
PQS5	0	Digital Input
	1	Digital Output
PQS6	0	Digital Input
	1	Digital Output
PQS7	0	Digital Input
	1	Digital Output

Table D-16 Effect of DDRQS on QSM Pin Function

QSM Pin	Mode	DDRQS Bit	Bit State	Pin Function
MISO	Master	DDQS0	0	Serial Data Input to QSPI
			1	Disables Data Input
	Slave		0	Disables Data Output
			1	Serial Data Output from QSPI
MOSI	Master	DDQS1	0	Disables Data Output
			1	Serial Data Output from QSPI
	Slave		0	Serial Data Input to QSPI
			1	Disables Data Input
SCK ¹	Master	DDQS2	0	Disables Clock Output
			1	Clock Output from QSPI
	Slave		0	Clock Input to QSPI
			1	Disables Clock Input
PCS0/SS	Master	DDQS3	0	Assertion Causes Mode Fault
			1	Chip-Select Output
	Slave		0	QSPI Slave Select Input
			1	Disables Select Input
PCS[3:1]	Master	DDQS [4:6]	0	Disables Chip-Select Output
			1	Chip-Select Output
	Slave		0	Inactive
			1	Inactive
TXD ²	Transmit	DDQS7	X	Serial Data Output from SCI
RXD	Receive	None	NA	Serial Data Input to SCI

1. PQS2 is a digital I/O pin unless the SPI is enabled (SPE in SPCR1 set), in which case it becomes SPI serial clock SCK.
2. PQS7 is a digital I/O pin unless the SCI transmitter is enabled (TE in SCCR1 =1), in which case it becomes SCI serial output TXD.

DDRQS determines the direction of the TXD pin only when the SCI transmitter is disabled. When the SCI transmitter is enabled, the TXD pin is an output.

D.4.10 SPCR0 — QSPI Control Register 0

\$YFFC18

15	14	13		10	9	8	7								0
MSTR	WOMQ	BITS			CPOL	CPHA	SP								
RESET:															
0	0	0	0	0	0	0	1	0	0	0	0	0	0	1	0

SPCR0 contains parameters for configuring the QSPI and enabling various modes of operation. The CPU has read/write access to SPCR0, but the QSM has read access only. SPCR0 must be initialized before QSPI operation begins. Writing a new value to SPCR0 while the QSPI is enabled disrupts operation.

MSTR — Master/Slave Mode Select

- 0 = QSPI is a slave device.
- 1 = QSPI is system master.

WOMQ — Wired-OR Mode for QSPI Pins

- 0 = Outputs have normal MOS drivers.
- 1 = Pins designated for output by DDRQS have open-drain drivers.

BITS — Bits Per Transfer

The BITS field determines the number of serial data bits transferred.

CPOL — Clock Polarity

- 0 = The inactive state value of SCK is logic level zero.
- 1 = The inactive state value of SCK is logic level one.

CPHA — Clock Phase

- 0 = Data captured on the leading edge of SCK and changed on the following edge of SCK.
- 1 = Data is changed on the leading edge of SCK and captured on the following edge of SCK.

SPBR — Serial Clock Baud Rate

QSPI baud rate is selected by writing a value from 2 to 255 into SPBR. Giving BR a value of zero or one disables SCK (disable state determined by CPOL).

D

D.4.11 SPCR1 — QSPI Control Register 1

\$YFFC1A

15	14		8	7		0
SPE	DSCKL				DTL	
RESET:						
0	0	0	0	0	1	0

SPCR1 enables the QSPI and specified transfer delays. The CPU32 has read/write access to SPCR1, but the QSM has read access only to all bits but enable bit SPE. SPCR1 must be written last during initialization because it contains SPE. Writing a new value to SPCR1 while the QSPI is enabled disrupts operation.

SPE — QSPI Enable

- 0 = QSPI is disabled. QSPI pins can be used for general-purpose I/O.
- 1 = QSPI is enabled. Pins allocated by PQSPAR are controlled by the QSPI.

DSCKL — Delay before SCK

When the DSCK bit in command RAM is set, this field determines the length of delay from PCS valid to SCK transition. PCS can be any of the four peripheral chip-select pins.

DTL — Length of Delay after Transfer

When the DT bit in command RAM is set, this field determines the length of delay after serial transfer.

D.4.12 SPCR2 — QSPI Control Register 2

\$YFFC1C

15	14	13	12	11		8	7	6	5	4	3		0
SPIFIE	WREN	WRTO	0	ENDQP			0	0	0	0	NEWQP		
RESET:													
0	0	0	0	0	0	0	0	0	0	0	0	0	0

SPCR2 contains QSPI queue pointers, wraparound mode control bits, and an interrupt enable bit. The CPU32 has read/write access to SPCR2, but the QSM has read access only. SPCR2 is buffered. New SPCR2 values become effective only after completion of the current serial transfer. Rewriting NEWQP in SPCR2 causes execution to restart at the designated location. SPCR2 reads return the value of the register, not the buffer.

SPIFIE — SPI Finished Interrupt Enable

- 0 = QSPI interrupts disabled
- 1 = QSPI interrupts enabled

WREN — Wrap Enable

- 0 = Wraparound mode disabled
- 1 = Wraparound mode enabled

WRTO — Wrap To

- 0 = Wrap to pointer address \$0
- 1 = Wrap to address in NEWQP

ENDQP — Ending Queue Pointer

This field contains the last QSPI queue address.

NEWQP — New Queue Pointer Value

This field contains the first QSPI queue address.

D.4.13 SPCR3 — QSPI Control Register 3

\$YFFC1E

SPSR — QSPI Status Register

\$YFFC1F

15	14	13	12	11	10	9	8	7	6	5	4	3		0
0	0	0	0	0	LOOPQ	HME	HALT	SPIF	MODF	HALTA	0	CPTQP		
RESET:														
0	0	0	0	0	0	0	0	0	0	0	0	0	0	0

SPCR3 contains the loop mode enable bit, halt and mode fault interrupt enables, and the halt control bit. The CPU has read/write access to SPCR3, but the QSM has read access only. SPCR3 must be initialized before QSPI operation begins. Writing a new value to SPCR3 while the QSPI is enabled disrupts operation. SPSR contains information concerning the current serial transmission. Only the QSPI can set bits in SPSR. The CPU reads SPSR to obtain QSPI status information and writes it to clear status flags.

LOOPQ — QSPI Loop Mode

0 = Feedback path disabled

1 = Feedback path enabled

HMIE — HALTA and MODF Interrupt Enable

0 = HALTA and MODF interrupts disabled

1 = HALTA and MODF interrupts enabled

HALT — Halt

0 = Halt not enabled

1 = Halt enabled

SPIF — QSPI Finished Flag

0 = QSPI not finished

1 = QSPI finished

MODF — Mode Fault Flag

0 = Normal operation

1 = Another SPI node requested to become the network SPI master while the QSPI was enabled in master mode (\overline{SS} input taken low).

HALTA — Halt Acknowledge Flag

0 = QSPI not halted

1 = QSPI halted

CPTQP — Completed Queue Pointer

CPTQP points to the last command executed. It is updated when the current command is complete. When the first command in a queue is executing, CPTQP contains either the reset value (\$0) or a pointer to the last command completed in the previous queue.

D.4.14 RR[0:F] — Receive Data RAM

\$YFFD00–\$YFFD0E

Data received by the QSPI is stored in this segment. The CPU32 reads this segment to retrieve data from the QSPI. Data stored in receive RAM is right-justified. Unused bits in a receive queue entry are set to zero by the QSPI upon completion of the individual queue entry. The CPU can access the data using byte, word, or long-word addressing.

D.4.15 TR[0:F] — Transmit Data RAM

\$YFFD20–\$YFFD3E

Data that is to be transmitted by the QSPI is stored in this segment. The CPU32 normally writes one word of data into this segment for each queue command to be executed.

Information to be transmitted must be written to transmit data RAM in a right-justified format. The QSPI cannot modify information in the transmit data RAM. The QSPI copies the information to its data serializer for transmission. Information remains in transmit RAM until overwritten.

D

D.4.16 CR[0:F] — Command RAM

\$YFFD40–\$YFFD4F

7	6	5	4	3	2	1	0
CONT	BITSE	DT	DSCK	PCS3	PCS2	PCS1	PCS0*
—	—	—	—	—	—	—	—
CONT	BITSE	DT	DSCK	PCS3	PCS2	PCS1	PCS0*

COMMAND CONTROL

PERIPHERAL CHIP SELECT

*The PCS0 bit represents the dual-function PCS0/ \overline{SS} .

Command RAM is used by the QSPI when in master mode. The CPU32 writes one byte of control information to this segment for each QSPI command to be executed. The QSPI cannot modify information in command RAM.

Command RAM consists of 16 bytes. Each byte is divided into two fields. The peripheral chip-select field enables peripherals for transfer. The command control field provides transfer options.

A maximum of 16 commands can be in the queue. Queue execution proceeds from the address in NEWQP through the address in ENDQP (both of these fields are in SPCR2).

CONT — Continue

- 0 = Control of chip selects returned to PORTQS after transfer is complete.
- 1 = Peripheral chip selects remain asserted after transfer is complete.

BITSE — Bits per Transfer Enable

- 0 = Eight bits
- 1 = Number of bits set in BITS field of SPCR0

DT — Delay after Transfer

The QSPI provides a variable delay at the end of serial transfer to facilitate interfacing with peripherals that have a latency requirement. The delay between transfers is determined by the SPCR1 DTL field.

DSCK — PCS to SCK Delay

- 0 = PCS valid to SCK transition is one-half SCK.
- 1 = SPCR1 DSCKL field specifies delay from PCS valid to SCK.

PCS[3:0] — Peripheral Chip Select

Peripheral chip-select bits are used to select an external device for serial data transfer. More than one peripheral chip select may be activated at a time, and more than one peripheral chip can be connected to each PCS pin, provided proper fanout is observed. PCS0 shares a pin with the slave select (\overline{SS}) signal, which initiates slave mode serial transfer. If \overline{SS} is taken low when the QSPI is in master mode, a mode fault occurs.

Table D-17 MC68331 Module Address Map

(Assumes SIMCR MM = 1)

GPT				
Access	Address	15	8 7	0
S	\$FFF900	GPT MODULE CONFIGURATION (GPTMCR)		
S	\$FFF902	(RESERVED FOR TEST)		
S	\$FFF904	INTERRUPT CONFIGURATION (ICR)		
S/U	\$FFF906	PGP DATA DIRECTION (DDRGP)	PGP DATA (PORTGP)	
S/U	\$FFF908	OC1 ACTION MASK (OC1M)	OC1 ACTION DATA (OC1D)	
S/U	\$FFF90A	TIMER COUNTER (TCNT)		
S/U	\$FFF90C	PA CONTROL (PACTL)	PA COUNTER (PACNT)	
S/U	\$FFF90E	INPUT CAPTURE 1 (TIC1)		
S/U	\$FFF910	INPUT CAPTURE 2 (TIC2)		
S/U	\$FFF912	INPUT CAPTURE 3 (TIC3)		
S/U	\$FFF914	OUTPUT COMPARE 1 (TOC1)		
S/U	\$FFF916	OUTPUT COMPARE 2 (TOC2)		
S/U	\$FFF918	OUTPUT COMPARE 3 (TOC3)		
S/U	\$FFF91A	OUTPUT COMPARE 4 (TOC4)		
S/U	\$FFF91C	INPUT CAPTURE 4/OUTPUT COMPARE 5 (TI4/O5)		
S/U	\$FFF91E	TIMER CONTROL 1 (TCTL1)	TIMER CONTROL 2 (TCTL2)	
S/U	\$FFF920	TIMER MASK 1 (TMSK1)	TIMER MASK 2 (TMSK2)	
S/U	\$FFF922	TIMER FLAG 1 (TFLG1)	TIMER FLAG 2 (TFLG2)	
S/U	\$FFF924	FORCE COMPARE (CFORC)	PWM CONTROL C (PWMC)	
S/U	\$FFF926	PWM CONTROL A (PWMA)	PWM CONTROL B (PWMB)	
S/U	\$FFF928	PWM COUNT (PWMCNT)		
S/U	\$FFF92A	PWMA BUFFER (PWMBUFA)	PWMB BUFFER (PWMBUFB)	
S/U	\$FFF92C	GPT PRESCALER (PRESCL)		
	\$FFF92E – \$FFF93F	NOT USED		
SIM				
Access	Address	15	8 7	0
S	\$FFFA00	MODULE CONFIGURATION (SIMCR)		
S	\$FFFA02	FACTORY TEST (SIMTR)		
S	\$FFFA04	CLOCK SYNTHESIZER CONTROL (SYNCR)		
S	\$FFFA06	NOT USED	RESET STATUS (RSR)	
S	\$FFFA08	MODULE TEST E (SIMTRE)		
S	\$FFFA0A	NOT USED	NOT USED	
S	\$FFFA0C	NOT USED	NOT USED	
S	\$FFFA0E	NOT USED	NOT USED	
S/U	\$FFFA10	NOT USED	PORTE DATA (PORTE0)	
S/U	\$FFFA12	NOT USED	PORTE DATA (PORTE1)	
S/U	\$FFFA14	NOT USED	PORTE DATA DIRECTION (DDRE)	
S	\$FFFA16	NOT USED	PORTE PIN ASSIGNMENT (PEPAR)	
S/U	\$FFFA18	NOT USED	PORTF DATA (PORTF0)	
S/U	\$FFFA1A	NOT USED	PORTF DATA (PORTF1)	
S/U	\$FFFA1C	NOT USED	PORTF DATA DIRECTION (DDRF)	
S	\$FFFA1E	NOT USED	PORTF PIN ASSIGNMENT (PFPAR)	
S	\$FFFA20	NOT USED	SYSTEM PROTECTION CONTROL (SYPCR)	
S	\$FFFA22	PERIODIC INTERRUPT CONTROL (PICR)		

D

Table D-17 MC68331 Module Address Map, (Continued)

(Assumes SIMCR MM = 1)

SIM (Continued)			
Access	Address	15	8 7 0
S	\$FFFA24	PERIODIC INTERRUPT TIMING (PITR)	
S	\$FFFA26	NOT USED	SOFTWARE SERVICE (SWSR)
S	\$FFFA28	NOT USED	NOT USED
S	\$FFFA2A	NOT USED	NOT USED
S	\$FFFA2C	NOT USED	NOT USED
S	\$FFFA2E	NOT USED	NOT USED
S	\$FFFA30	TEST MODULE MASTER SHIFT A (TSTMSRA)	
S	\$FFFA32	TEST MODULE MASTER SHIFT B (TSTMSRB)	
S	\$FFFA34	TEST MODULE SHIFT COUNT (TSTSC)	
S	\$FFFA36	TEST MODULE REPETITION COUNTER (TSTRC)	
S	\$FFFA38	TEST MODULE CONTROL (CREG)	
S/U	\$FFFA3A	TEST MODULE DISTRIBUTED (DREG)	
	\$FFFA3C	NOT USED	NOT USED
	\$FFFA3E	NOT USED	NOT USED
S/U	\$FFFA40	NOT USED	PORT C DATA (PORTC)
	\$FFFA42	NOT USED	NOT USED
S	\$FFFA44	CHIP-SELECT PIN ASSIGNMENT (CSPAR0)	
S	\$FFFA46	CHIP-SELECT PIN ASSIGNMENT (CSPAR1)	
S	\$FFFA48	CHIP-SELECT BASE BOOT (CSBARBT)	
S	\$FFFA4A	CHIP-SELECT OPTION BOOT (CSORBT)	
S	\$FFFA4C	CHIP-SELECT BASE 0 (CSBAR0)	
S	\$FFFA4E	CHIP-SELECT OPTION 0 (CSOR0)	
S	\$FFFA50	CHIP-SELECT BASE 1 (CSBAR1)	
S	\$FFFA52	CHIP-SELECT OPTION 1 (CSOR1)	
S	\$FFFA54	CHIP-SELECT BASE 2 (CSBAR2)	
S	\$FFFA56	CHIP-SELECT OPTION 2 (CSOR2)	
S	\$FFFA58	CHIP-SELECT BASE 3 (CSBAR3)	
S	\$FFFA5A	CHIP-SELECT OPTION 3 (CSOR3)	
S	\$FFFA5C	CHIP-SELECT BASE 4 (CSBAR4)	
S	\$FFFA5E	CHIP-SELECT OPTION 4 (CSOR4)	
S	\$FFFA60	CHIP-SELECT BASE 5 (CSBAR5)	
S	\$FFFA62	CHIP-SELECT OPTION 5 (CSOR5)	
S	\$FFFA64	CHIP-SELECT BASE 6 (CSBAR6)	
S	\$FFFA66	CHIP-SELECT OPTION 6 (CSOR6)	
S	\$FFFA68	CHIP-SELECT BASE 7 (CSBAR7)	
S	\$FFFA6A	CHIP-SELECT OPTION 7 (CSOR7)	
S	\$FFFA6C	CHIP-SELECT BASE 8 (CSBAR8)	
S	\$FFFA6E	CHIP-SELECT OPTION 8 (CSOR8)	
S	\$FFFA70	CHIP-SELECT BASE 9 (CSBAR9)	
S	\$FFFA72	CHIP-SELECT OPTION 9 (CSOR9)	
S	\$FFFA74	CHIP-SELECT BASE 10 (CSBAR10)	
S	\$FFFA76	CHIP-SELECT OPTION 10 (CSOR10)	
	\$FFFA78	NOT USED	NOT USED
	\$FFFA7A	NOT USED	NOT USED
	\$FFFA7C	NOT USED	NOT USED
	\$FFFA7E	NOT USED	NOT USED

Table D-17 MC68331 Module Address Map, (Continued)

(Assumes SIMCR MM = 1)

QSM			
Access	Address	15	8 7
S	\$FFFC00	QSM MODULE CONFIGURATION (QSMCR)	
S	\$FFFC02	QSM TEST (QTEST)	
S	\$FFFC04	QSM INTERRUPT LEVEL (QILR)	QSM INTERRUPT VECTOR (QIVR)
S/U	\$FFFC06	NOT USED	
S/U	\$FFFC08	SCI CONTROL 0 (SCCR0)	
S/U	\$FFFC0A	SCI CONTROL 1 (SCCR1)	
S/U	\$FFFC0C	SCI STATUS (SCSR)	
S/U	\$FFFC0E	SCI DATA (SCDR)	
S/U	\$FFFC10	NOT USED	
S/U	\$FFFC12	NOT USED	
S/U	\$FFFC14	NOT USED	PQS DATA (PORTQS)
S/U	\$FFFC16	PQS PIN ASSIGNMENT (PQSPAR)	PQS DATA DIRECTION (DDRQS)
S/U	\$FFFC18	SPI CONTROL 0 (SPCR0)	
S/U	\$FFFC1A	SPI CONTROL 1 (SPCR1)	
S/U	\$FFFC1C	SPI CONTROL 2 (SPCR2)	
S/U	\$FFFC1E	SPI CONTROL 3 (SPCR3)	SPI STATUS (SPSR)
S/U	\$FFFC20– \$FFFCFF	NOT USED	
S/U QUEUE RAM	\$FFFD00– \$FFFD1F	RECEIVE RAM (RR[0:F])	
S/U QUEUE RAM	\$FFFD20– \$FFFD3F	TRANSMIT RAM (TR[0:F])	
S/U QUEUE RAM	\$FFFD40– \$FFFD4F	COMMAND RAM (CR[0:F])	

D

Table D-18 Register Bit and Field Mnemonics

Mnemonic	Name	Register Location
ADDR[23:11]	Base Address	CSBAR[0:10], CSBARBT
AVEC	Autovector Enable	CSOR[0:10], CSORBT
BITS	Bits Per Transfer	SPCR0
BITSE	Bits Per Transfer Enable	CR[0:F]
BLKSZ	Block Size	CSBAR[0:10], CSBARBT
BME	Bus Monitor External Enable	SYPCR
BMT[1:0]	Bus Monitor Timing	SYPCR
BYTE	Upper/Lower Byte Option	CSOR[0:10], CSORBT
C	Carry Flag	CCR
CONT	Continue	CR[0:F]
CPHA	Clock Phase	SPCR0
CPOL	Clock Polarity	SPCR0
CPROUT	Capture/Compare Clock Output Enable	TMSK2
CPR[2:0]	Timer Prescaler/PCLK Select Field	TMSK2
CPTQP	Completed Queue Pointer	SPSR
CSPA0[6:1]	Chip-Select [6:1]	CSPAR0
CSPA1[4:0]	Chip-Select [4:0]	CSPAR1
CSBOOT	Boot ROM Chip Select	CSPAR0
DDE[7:0]	Port E Data Direction	DDRE
DDF[7:0]	Port F Data Direction	DDRF
DDRGP[7:0]	Port GP Data Direction	DDRGP
DDQS[7:0]	Port QS Data Direction	DDRQS
DSACK	Data Strobe Acknowledge	CSOR[0:10], CSORBT
DSCK	PCS to SCK Delay	CR[0:F]
DSCKL	Delay Before SCK	SPCR1
DT	Delay After Transfer	CR[0:F]
DTL	Length of Delay After Transfer	SPCR1
EDGE[4:1]	Input Capture Edge Control	TCTL2
EDIV	ECLK Divide Rate	SYNCR
ENDQP	Ending Queue Pointer	SPCR2
EXOFF	External Clock Off	SIMCR
EXT	External Reset	RSR
F1A	Force Logic Level One on PWMA	PWMC
F1B	Force Logic Level One on PWMB	PWMC
FE	Framing Error	SCSR
FOC[5:1]	Force Output Compare	CFORC
FPWMA	Force PWMA Value	CFORC
FPWMB	Force PWMB Value	CFORC
FRZBM	Freeze Bus Monitor Enable	SIMCR
FRZSW	Freeze Software Enable	SIMCR
FRZ[1:0]	Freeze Response	GPTMCR
FRZ[1:0]	Freeze1	QSMCR
HALT	Halt	SPCR3
HALTA	Halt Acknowledge Flag	SPSR
HLT	Halt Monitor Reset	RSR
HME	Halt Monitor Enable	SYPCR
HMIE	HALTA and MODF Interrupt Enable	SPCR3

Table D-18 Register Bit and Field Mnemonics, (Continued)

Mnemonic	Name	Register Location
I4/O5	Input Capture 4/Output Compare 5	PACNT
I4/O5F	Input Capture 4/Output Compare 5 Flag	TFLG1
I4/O5I	I4/O5 Interrupt Enable	TMSK1
IARB[3:0]	Interrupt Arbitration	GPTMCR, QSMCR, SIMCR
ICF[3:1]	Input Capture Flags	TFLG1
ICI[3:1]	Input Capture Interrupt Enable	TMSK1
IDLE	Idle-Line Detected	SCSR
ILIE	Idle-Line Interrupt Enable	SCCR1
ILQSPI	Interrupt Level for QSPI	QILR
ILSCI	Interrupt Level for SCI	QILR
ILT	Idle-Line Detect Type	SCCR1
INCP	Increment Prescaler	GPTMCR
INTV[7:0]	Interrupt Vector Number	QIVR
IP[2:0]	Interrupt Priority Mask	SR
IPA	Interrupt Priority Adjust	ICR
IPL	Interrupt Priority Level	CSOR[0:10], CSORBT, ICR
IVBA	Interrupt Vector Base Address	ICR
LOC	Loss of Clock Reset	RSR
LOOPQ	QSPI Loop Mode	SPCR3
LOOPS	Loop Mode	SCCR1
M	Mode Select	SCCR1
MM	Module Mapping	SIMCR
MODE	Asynchronous/Synchronous Mode	CSOR[0:10], CSORBT
MODF	Mode Fault Flag	SPSR
MSTR	Master/Slave Mode Select	SPCR0
N	Negative Flag	CCR
NEWQP	New Queue Pointer Value	SPCR2
NF	Noise Error	SCSR
OC1D[5:1]	OC1 Data	OC1D
OC1M[5:1]	OC1 Mask	OC1M
OCF[4:1]	Output Compare Flags	TFLG1
OCI[4:1]	Output Compare Interrupt Enable	TMSK1
OM[5:2]	Output Compare Mode Bits	TCTL1
OL[5:2]	Output Compare Level Bits	TCTL1
OR	Overrun Error	SCSR
PACLK[1:0]	Pulse Accumulator Clock Select (Gated Mode)	PACNT
PACNT	Pulse Accumulator Counter	PACNT
PAEN	Pulse Accumulator Enable	PACNT
PAIF	Pulse Accumulator Flag	TFLG2
PAII	Pulse Accumulator Input Interrupt Enable	TMSK2
PAIS	PAI Pin State (Read Only)	PACNT
PAMOD	Pulse Accumulator Mode	PACNT
PAOVF	Pulse Accumulator Overflow Flag	TFLG2
PAOVI	Pulse Accumulator Overflow Interrupt Enable	TMSK2
PC[6:0]	Port C Data	PORTC

D

Table D-18 Register Bit and Field Mnemonics, (Continued)

Mnemonic	Name	Register Location
PCLKS	PCLK Pin State (Read Only)	PACNT
PCS[3:0]	Peripheral Chip Select	CR[0:F]
PE	Parity Enable	SCCR1
PE[7:0]	Port E Data	PORTE
PEDGE	Pulse Accumulator Edge Control	PACNT
PEPA[7:0]	Port E Pin Assignment	PEPAR
PF	Parity Error	SCSR
PF[7:0]	Port F Data	PORTF
PFFPA[7:0]	Port F Pin Assignment	PFFPAR
PORTGP[7:0]	Port GP Data	PORTGP
PIRQL[2:0]	Periodic Interrupt Request Level	PICR
PITM[7:0]	Periodic Interrupt Timing Modulus	PITR
PIV[7:0]	Periodic Interrupt Vector	PICR
POW	Power-Up Reset	RSR
PPROUT	PWM Clock Output Enable	PWMC
PPR[2:0]	PWM Prescaler/PCLK Select	PWMC
PQS[7:0]	Port QS Data	PORTQS
PQSPA[6:0]	Port QS Pin Assignment	PQSPAR
PT	Parity Type	SCCR1
PTP	Periodic Timer Prescaler Control	PITR
RAF	Receiver Active	SCSR
RDRF	Receive Data Register Full	SCSR
RE	Receiver Enable	SCCR1
RIE	Receiver Interrupt Enable	SCCR1
RR[0:F]	Receive Data RAM	QSPI RAM
RSTEN	Reset Enable	SYNCR
R \bar{W}	Read/Write	CSOR[0:10], CSORBT
RWU	Receiver Wakeup	SCCR1
R[8:0]/T[8:0]	SCI Receive/Transmit Data	SCDR
S	Supervisor/User State	SR
SBK	Send Break	SCCR1
SCBR	SCI Baud Rate	SCCR0
SFA	PWMA Slow/Fast Select	PWMC
SFB	PWMB Slow/Fast Select	PWMC
SHEN[1:0]	Show Cycle Enable	SIMCR
SLIMP	LIMP Mode	SYNCR
SLOCK	Synthesizer Lock	SYNCR
SLVEN	Factory Test Mode Enabled	SIMCR
SPACE	Address Space Select	CSOR[0:10], CSORBT
SPBR	Serial Clock Baud Rate	SPCR0
SPE	QSPI Enable	SPCR1
SPIF	QSPI Finished Flag	SPSR
SPIFIE	SPI Finished Interrupt Enable	SPCR2
STEXT	Stop Mode External Clock	SYNCR
STOP	Stop Clocks	GPTMCR
STOP	Stop Enable	QSMCR
STOPP	Stop Prescaler	GPTMCR
STRB	Address Strobe/Data Strobe	CSOR[0:10], CSORBT

Table D-18 Register Bit and Field Mnemonics, (Continued)

Mnemonic	Name	Register Location
STSIM	Stop Mode System Integration Clock	SYNCR
SUPV	Supervisor/Unrestricted	GPTMCR, QSMCR, SIMCR
SW	Software Watchdog Reset	RSR
SWE	Software Watchdog Enable	SYPCR
SWP	Software Watchdog Prescale	SYPCR
SWT[1:0]	Software Watchdog Timing	SYPCR
SYS	System Reset	RSR
T[1:0]	Trace Enable	SR
TC	Transmit Complete	SCSR
TCIE	Transmit Complete Interrupt Enable	SCCR1
TDRE	Transmit Data Register Empty	SCSR
TE	Transmitter Enable	SCCR1
TIE	Transmit Interrupt Enable	SCCR1
TOF	Timer Overflow Flag	TFLG2
TOI	Timer Overflow Interrupt Enable	TMSK2
TR[0:F]	Transmit Data RAM	QSPI RAM
TST	Test Submodule Reset	RSR
V	Overflow Flag	CCR
W	Frequency Control (VCO)	SYNCR
WAKE	Wakeup by Address Mark	SCCR1
WOMQ	Wired-OR Mode for QSPI Pins	SPCR0
WOMS	Wired-OR Mode for SCI Pins	SCCR1
WREN	Wrap Enable	SPCR2
WRTO	Wrap To	SPCR2
X	Extend	CCR
X	Frequency Control Bit (Prescale)	SYNCR
Y[5:0]	Frequency Control (Counter)	SYNCR
Z	Zero Flag	CCR

D





INDEX



Компания «Life Electronics» занимается поставками электронных компонентов импортного и отечественного производства от производителей и со складов крупных дистрибьюторов Европы, Америки и Азии.

С конца 2013 года компания активно расширяет линейку поставок компонентов по направлению коаксиальный кабель, кварцевые генераторы и конденсаторы (керамические, пленочные, электролитические), за счёт заключения дистрибьюторских договоров

Мы предлагаем:

- Конкурентоспособные цены и скидки постоянным клиентам.
- Специальные условия для постоянных клиентов.
- Подбор аналогов.
- Поставку компонентов в любых объемах, удовлетворяющих вашим потребностям.
- Приемлемые сроки поставки, возможна ускоренная поставка.
- Доставку товара в любую точку России и стран СНГ.
- Комплексную поставку.
- Работу по проектам и поставку образцов.
- Формирование склада под заказчика.
- Сертификаты соответствия на поставляемую продукцию (по желанию клиента).
- Тестирование поставляемой продукции.
- Поставку компонентов, требующих военную и космическую приемку.
- Входной контроль качества.
- Наличие сертификата ISO.

В составе нашей компании организован Конструкторский отдел, призванный помогать разработчикам, и инженерам.

Конструкторский отдел помогает осуществить:

- Регистрацию проекта у производителя компонентов.
- Техническую поддержку проекта.
- Защиту от снятия компонента с производства.
- Оценку стоимости проекта по компонентам.
- Изготовление тестовой платы монтаж и пусконаладочные работы.



Тел: +7 (812) 336 43 04 (многоканальный)
Email: org@lifeelectronics.ru