

RFFM6404

2.5V to 4.5V, ISM Band, 27.5dBm, 430MHz to 450MHz Transmit/Receive Module

The RFFM6404 is a single-chip front end module (FEM) for applications in the 430MHz and 450MHz ISM Bands. The RFFM6404 addresses the need for aggressive size reduction for typical portable equipment RF front-end design and greatly reduces the number of components outside of the core chipset thus minimizing the footprint and assembly cost of the overall solution. The RFFM6404 contains an integrated 27.5dBm PA, SP2T Antenna switch, integrated Tx harmonic filter, LNA with bypass mode, and matching components. The RFFM6404 is packaged in a 28-pin, 6.0mm x 6.0mm x 0.975mm over-molded laminate package with backside ground which greatly minimizes next level board space and allows for simplified integration.



Package: LGA, 28-pin, 6.0mm x 6.0mm x 0.975mm

Features

- Integrated 50Ω Input/Output Match
- Tx Output Power: 27.5dBm
- Separate Tx/Rx 50Ω transceiver interface
- Integrated PA, filtering LNA with Bypass Mode

Applications

- 400MHz ISM Bands
- Single Chip RF Front End Module
- Wireless Automatic Metering
- Portable Battery Powered Equipment
- Smart Energy

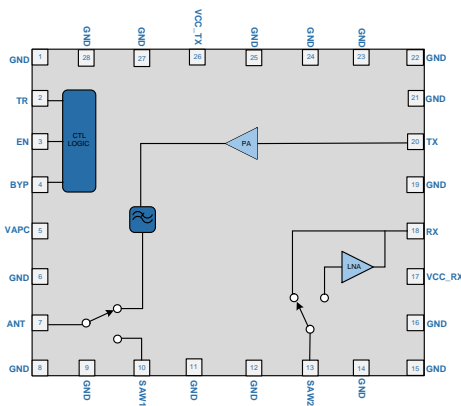

Functional Block Diagram

Ordering Information

RFFM6404SB	Standard 5-piece bag
RFFM6404SQ	Standard 25-piece bag
RFFM6404SR	Standard 100-piece reel
RFFM6404TR13	Standard 2500-piece reel
RFFM6404PCK-410	Fully Assembled Evaluation Board w/ 5-piece bag

Absolute Maximum Ratings

Parameter	Rating	Unit
Voltage	5.25	V
Storage Temperature Range	-40 to +150	°C
Operating Temperature Range	-40 to +85	°C
Receive RF Input Power (SAW2)	+25	dBm
Transmit RF Input Power (PA Enabled)	+15	dBm
Receive RF Input Power (ANT)	+33	dBm
T/R Port Load VSWR in Transmit Mode	10:1	
ESD, HBM	500	V
ESD, CDM	1000	V
Moisture Sensitivity Level	MSL3	



Caution! ESD sensitive device.



RFMD Green: RoHS status based on EU Directive 2011/65/EU (at time of this document revision), halogen free per IEC 61249-2-21, < 1000ppm each of antimony trioxide in polymeric materials and red phosphorus as a flame retardant, and <2% antimony in solder.

Exceeding any one or a combination of the Absolute Maximum Rating conditions may cause permanent damage to the device. Extended application of Absolute Maximum Rating conditions to the device may reduce device reliability. Specified typical performance or functional operation of the device under Absolute Maximum Rating conditions is not implied.

Nominal Operating Parameters

Parameter	Specification			Unit	Condition
	Min	Typ	Max		
Frequency	430		450	MHz	
RF Port Impedance		50		Ω	
Operating Voltage	2.5	4.2	4.5	V	V _{CC} TX & V _{CC} RX
V _{APC} (Tx Output Power Control)	0.0	2.7	3.0	V	V _{APC} operates such that the transmitter output power is saturated at a level lower than 1.9V and minimal variation in output power of the device occurs above that level
Leakage Current					RF:Off, V_{CC}TX=4.2V, V_{CC}RX=4.2V, V_{APC}=0.0V, EN=0.0V, TR=0.0V, BYP=0.0V, Temperature=25°C
Total FEM Leakage Current		0.1	1.0	μA	I _{CC} TX + I _{CC} RX
Transmit High Power Mode					Measured Path: TX to ANT, V_{CC}TX=4.2V, V_{CC}RX=4.2V, V_{APC}=2.7V, EN=1.8V, TR=1.8V, BYP=0.2V, Temperature=25°C
Gain	25.5	26.5		dB	V _{CC} TX=4.2V, P _{IN} =+3dBm
	21.5	22.5		dB	V _{CC} TX=2.7V, P _{IN} =+3dBm
Output Power		29.5		dBm	V _{CC} TX=4.2V, P _{IN} =+3dBm
		27.5		dBm	V _{CC} TX=3.6V, P _{IN} =+3dBm
	24.5	25.5		dBm	V _{CC} TX=2.7V, P _{IN} =+3dBm
Output Power Variation	-0.4		-0.4	dB	V _{CC} TX=4.2V, P _{IN} =+3dBm, Over frequency and control voltage
Output P3dB		29		dBm	V _{CC} TX=4.2V
Operating Current		350		mA	V _{CC} TX=4.2V, P _{OUT} =27.5dBm, I _{CC} TX
		450	600	mA	V _{CC} TX=4.2V, P _{IN} =+3dBm, I _{CC} TX
Quiescent Current		100		mA	I _{CC} TX, RF = Off
Second Harmonic			-30	dBc	P _{OUT} =27.5dBm
			-50	dBc	P _{OUT} =27.5dBm, with harmonic filter
Third – Fourth Harmonic			-40	dBc	P _{OUT} =27.5dBm
			-60	dBc	P _{OUT} =27.5dBm, with harmonic filter
Fifth – Tenth Harmonic			-60	dBc	P _{OUT} =27.5dBm
			-60	dBc	P _{OUT} =27.5dBm, with harmonic filter
Module PAE		45		%	V _{CC} TX=4.2V, P _{OUT} =29.5dBm (takes into account filter and switches)

Parameter	Specification			Unit	Condition
	Min	Typ	Max		
PA PAE		TBD		%	$V_{CCTX}=4.2V$, $P_{OUT}=29.5dBm$ (excludes losses of module filter and switches)
Input Return Loss	9			dB	
Output Return Loss	7			dB	
Receive Mode					Measured Path: SAW2 to RX, $V_{CCTX}=4.2V$, $V_{CCRX}=4.2V$, $V_{APC}=0.0V$, $EN=1.8V$, $TR=0.2V$, $BYP=0.2V$, Temperature=$25^{\circ}C$
Gain	14.0	15.5	18.0	dB	
Noise Figure	1.7	1.9	2.5	dB	
IP1dB	-6.0	-3.5		dBm	
IIP3	3			dBm	
Operating Current	4.0	5.0	8.0	mA	
Input Return Loss	10			dB	
Output Return Loss	10			dB	
Receive Bypass Mode					Measured Path: SAW2 to RX, $V_{CCTX}=4.2V$, $V_{CCRX}=4.2V$, $V_{APC}=0.0V$, $EN=1.8V$, $TR=0.2V$, $BYP=1.8V$, Temperature=$25^{\circ}C$
Insertion Loss		2	5	dB	
IP1dB	21.0	22.5		dBm	
IIP3	44	47		dBm	1MHz Spacing
VccTX Supply Current		370	500	μA	
VccRx Supply Current		70	200	μA	
Input Return Loss	8			dB	
Output Return Loss	8			dB	
Antenna Switch					Measured Path: ANT to SAW1, RX & RX Bypass Modes
Insertion Loss		0.5		dB	
IP1dB		33		dB	
IIP3		54		dB	
Input Return Loss	17			dB	
Output Return Loss	17			dB	
Isolation					
Isolation	30			dB	ANT to SAW1, Transmit High Power Mode
Logic					EN, TR, BYP
Control Logic HIGH	1.6		4.3	V	Max Control Logic High = $V_{CCTX}/V_{CCRX} - 0.2VDC$
Control Logic LOW		0.2	0.3	V	
Control Logic HIGH Current		10	500	nA	
Control Logic LOW Current		0.1		μA	
V _{APC} HIGH Current		50	100	μA	Across all rated voltages at rated power

Switch Control Truth Table

Operating Mode	TR (Pin 2)	EN (Pin 3)	BYP (Pin 4)	PA	LNA
Transmit	High	High	Low	ON	OFF
Receive	Low	High	Low	OFF	ON
Receive Bypass	Low	High	High	OFF	OFF
Shutdown	X	Low	X	OFF	OFF

Application Schematic (without external filter)

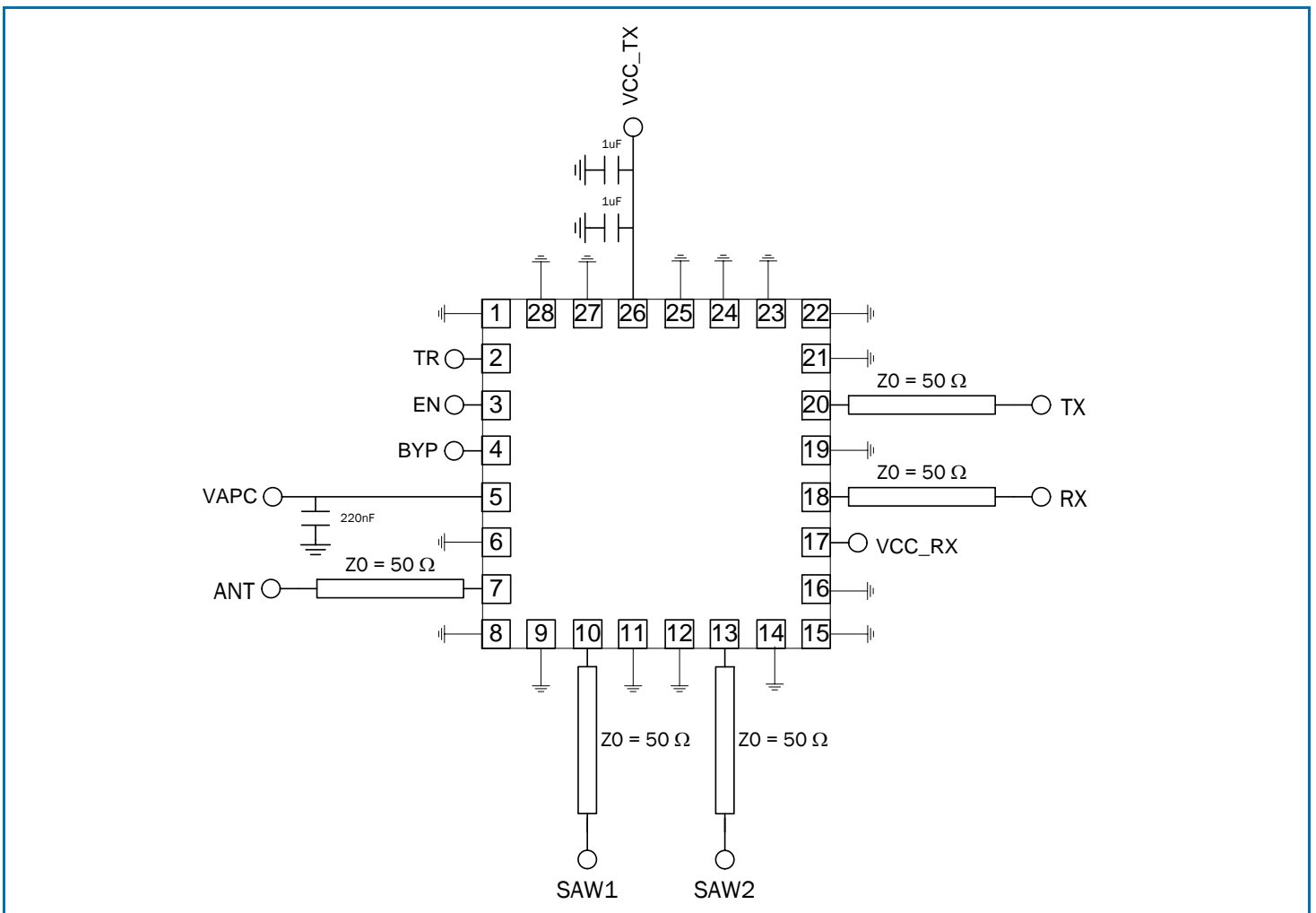

Application Schematic (with external filter)

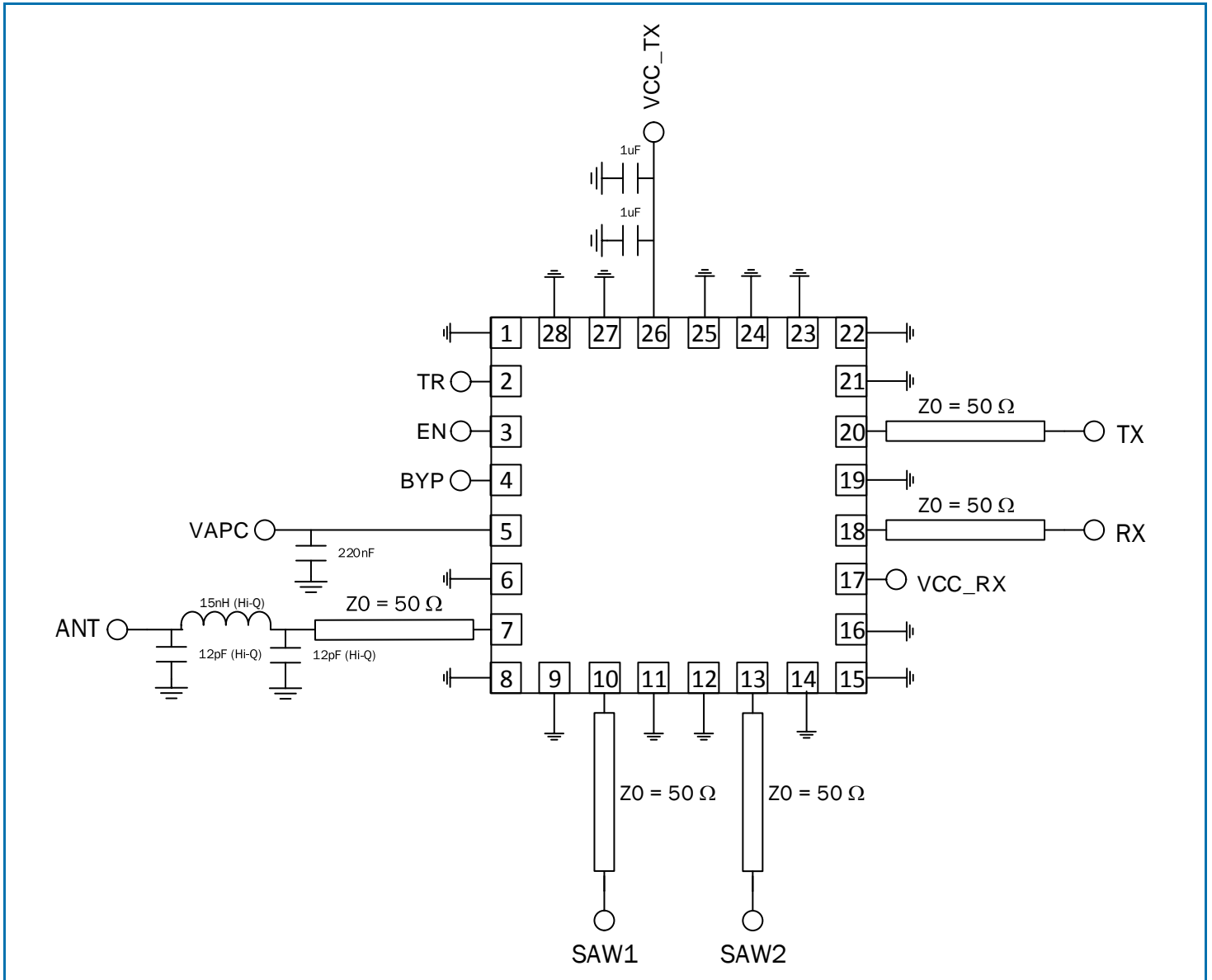

Pin Out

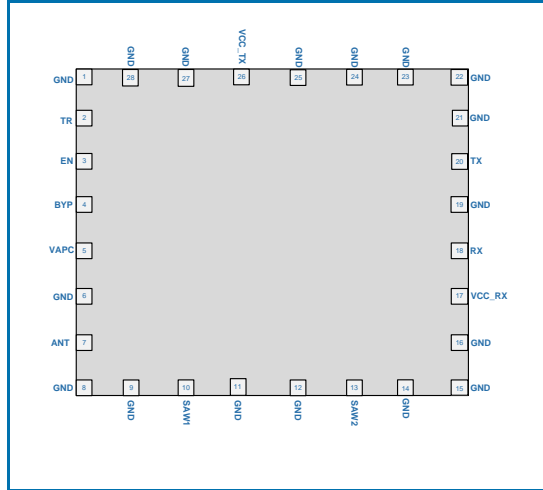

Package Outline and Branding Drawing (Dimensions in millimeters)

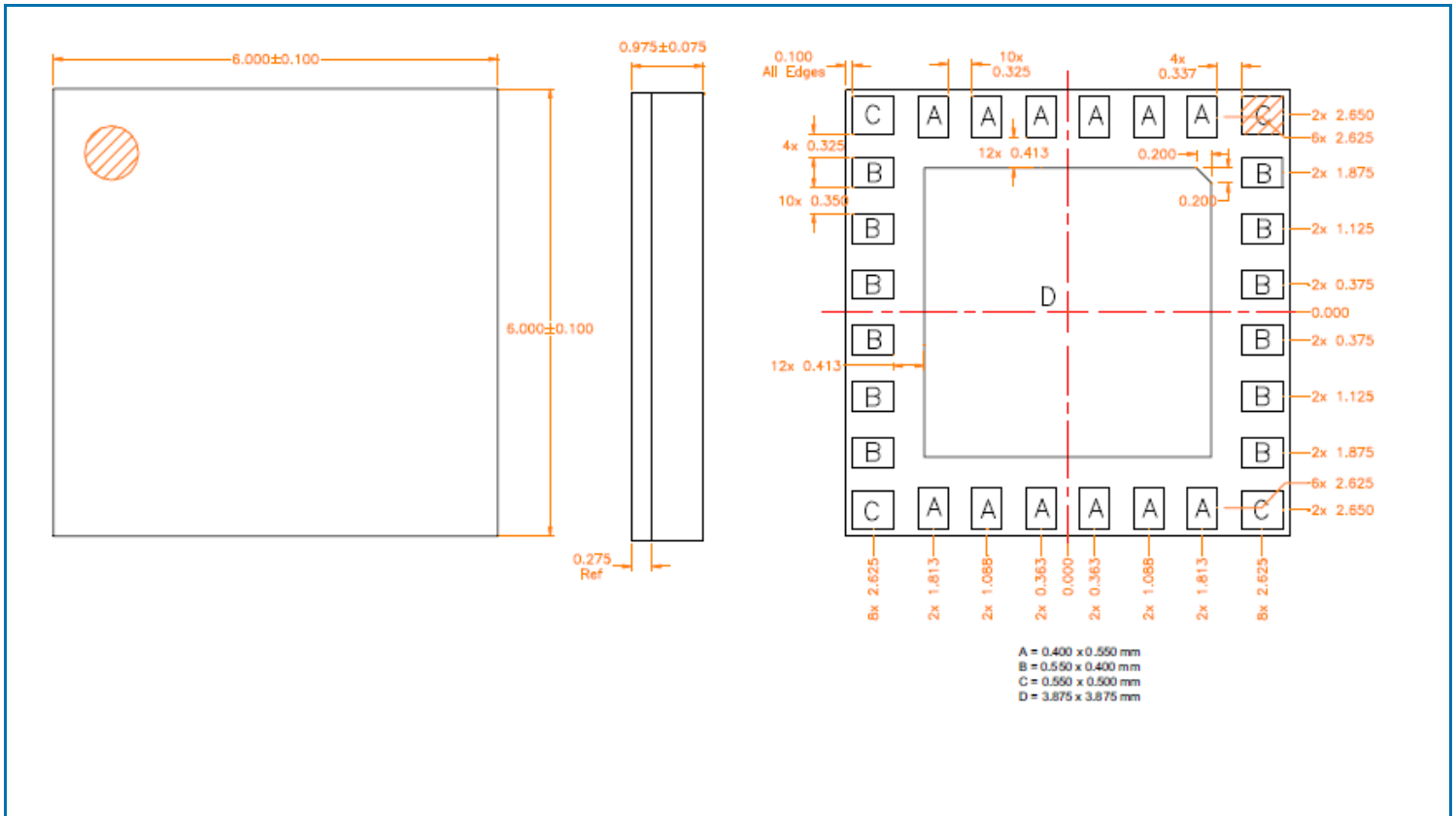

PCB Patterns

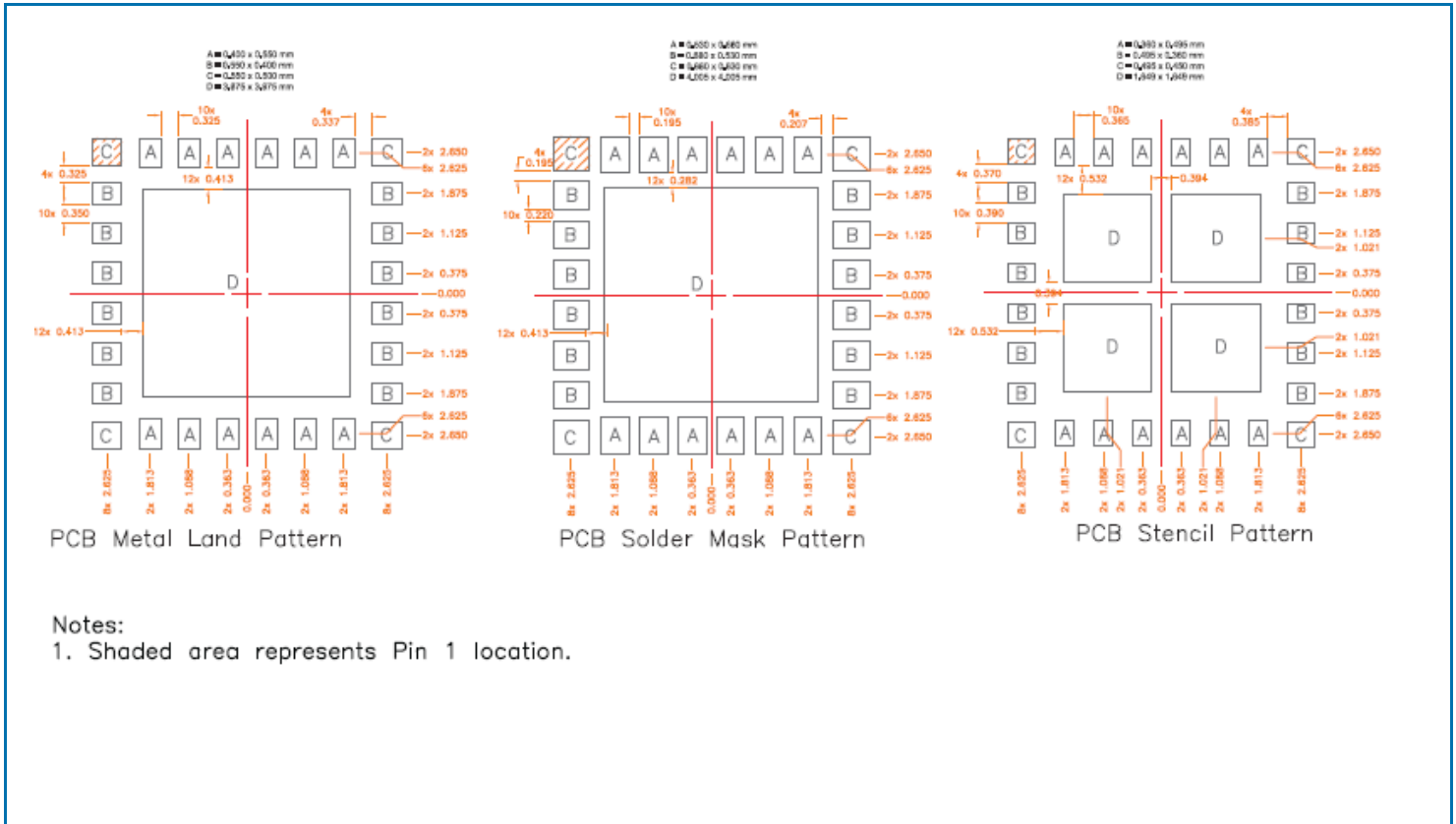

Pin Names and Descriptions

Pin	Name	Description
1	GND	Ground
2	TR	Digital Input: Transmit/Receive
3	EN	Digital Input: FEM Enable
4	BYP	Digital Input: RX Bypass Mode
5	VAPC	Analog Input; TX Output Power Control
6	GND	Ground
7	ANT	Antenna Switch Common Port, internally matched to 50Ω, DC Blocked
8	GND	Ground
9	GND	Ground
10	SAW1	Receive side of antenna switch, internally matched to 50Ω, DC Blocked
11	GND	Ground
12	GND	Ground
13	SAW2	RX and RX bypass input port, internally matched to 50Ω, DC Blocked
14	GND	Ground
15	GND	Ground
16	GND	Ground
17	VCC_RX	4.2V power supply
18	RX	Receive output, internally matched to 50Ω, DC Blocked
19	GND	Ground
20	TX	TX input port, internally matched to 50Ω, DC Blocked
21	GND	Ground
22	GND	Ground
23	GND	Ground
24	GND	Ground
25	GND	Ground
26	VCC_TX	4.2V power supply
27	GND	Ground
28	GND	Ground

Компания «Life Electronics» занимается поставками электронных компонентов импортного и отечественного производства от производителей и со складов крупных дистрибьюторов Европы, Америки и Азии.

С конца 2013 года компания активно расширяет линейку поставок компонентов по направлению коаксиальный кабель, кварцевые генераторы и конденсаторы (керамические, пленочные, электролитические), за счёт заключения дистрибьюторских договоров

Мы предлагаем:

- Конкурентоспособные цены и скидки постоянным клиентам.
- Специальные условия для постоянных клиентов.
- Подбор аналогов.
- Поставку компонентов в любых объемах, удовлетворяющих вашим потребностям.
- Приемлемые сроки поставки, возможна ускоренная поставка.
- Доставку товара в любую точку России и стран СНГ.
- Комплексную поставку.
- Работу по проектам и поставку образцов.
- Формирование склада под заказчика.
- Сертификаты соответствия на поставляемую продукцию (по желанию клиента).
- Тестирование поставляемой продукции.
- Поставку компонентов, требующих военную и космическую приемку.
- Входной контроль качества.
- Наличие сертификата ISO.

В составе нашей компании организован Конструкторский отдел, призванный помогать разработчикам, и инженерам.

Конструкторский отдел помогает осуществить:

- Регистрацию проекта у производителя компонентов.
- Техническую поддержку проекта.
- Защиту от снятия компонента с производства.
- Оценку стоимости проекта по компонентам.
- Изготовление тестовой платы монтаж и пусконаладочные работы.



Тел: +7 (812) 336 43 04 (многоканальный)
Email: org@lifeelectronics.ru