



| 2CP5 & 2CP50 SERIES

HVAC/Refrigeration Pressure Sensor

Introduction

The 2CP series is ideal for demanding air conditioning and refrigeration applications where long-term reliability and accuracy is a must. The 2CP series provides proven reliability at a competitive price.

Sensata Technologies has been a leading global supplier of pressure sensors and switches for over 50 years. The 2CP has many options, consult the factory to customize a 2CP to meet your application's needs.



Features

- UL recognized
- Ceramic capacitive sensor
- Durable, compact, low-cost design
- Accurate performance over wide temperatures
- Overvoltage and short circuit protected

Applications

- Discharge and suction pressure monitoring
- Subcooling and superheat calculations
- Compressor oil pressure monitoring
- Condenser fan control
- Compressor staging and unloading
- Electronic expansion valve control
- Remote systems diagnostics and trending



SPECIFICATIONS

Pressure Ranges	0 to 15 psi, through 0 to 750 psi
Accuracy	±0.8% F.S. (linearity, hysteresis, repeatability and calibration) Static error band @ 25°C, 5.0VDC
Total Error Band	±1.0% (-20°C to +85°C) ±1.5% (-40°C to +125°C)
Operating Temperature	-40°C to +135°C
Storage Temperature	40°C to +150°C
Proof Pressure	5X 15 to 75 psi, 3X 100 to 300 psi, 2X 500+ psi
Burst Pressure	2CP5 - 5x operating pressure 2CP50 - 3x operating pressure
Cycle Life	10M F.S. cycles
Random Vibration	11g (50 to 2000 Hz)
Drop (any Axis)	1.5m
Electrical Connection	Nema 4X, IP65

Supply Voltage	4.5 to 5.5 VDC
Output Voltage	0.5 to 4.5 VDC typical
Supply Current	7 mA (max @ 5.5 VDC no load)
Output Current	2.5 mA (max sinked or source)
Output Load	10K ohms typical
Output Response Time	10mS
Overtoltage Protection	16 VDC
Reverse Voltage	-14 VDC
Short Circuit Protected	Yes
EMC (512MHz to 1 GHz)	50 V/m
EMC (1 MHz to 512 MHz)	100 V/m
ESD (CDF-AEC-Q100-002)	15 kV

STANDARDS

Sample PN	Production PN	Description
2CP5B0520150ANN	2CP5-71-46	Brass, 0 to 150 psia
2CP5B0520200ANN	ANN 2CP5-71-49	Brass, 0 to 200 psia
2CP5B0520300SNN	NN 2CP5-71-50	Brass, 0 to 300 psia
2CP5B0520400SNN	N 2CP5-71-51	Brass, 0 to 400 psia
2CP5B0520500SNN	2CP5-71-47	Brass, 0 to 500 psia
2CP5S0520500SNN	2CP5-71-48	Steel, 0 to 500 psia

SEAL MATERIALS

Material	Refridgerant	Maximum Seal Temperature Range
HNBR (Hydrogenated Nitrile)	R134a, R404a, R407c, R410a, R507	-20°C to 135°C
Neoprene	R12, R22, R134a, R404a, R407c, R410a, R502, R507	-40°C to 120°C

DIMENSIONAL DRAWINGS

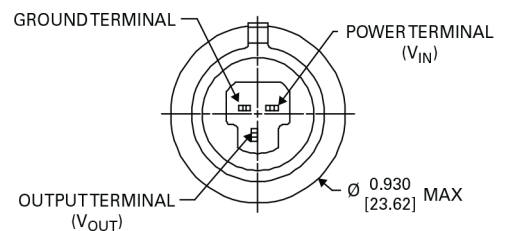
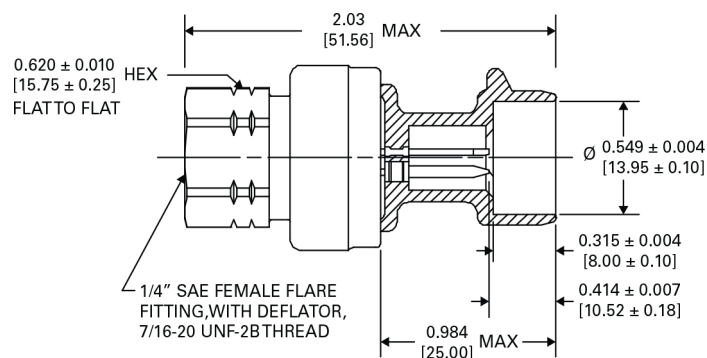

INCHES (MM)



ORDERING OPTIONS

Example : 2CP5-S-05-2-XXXX-A-N-N

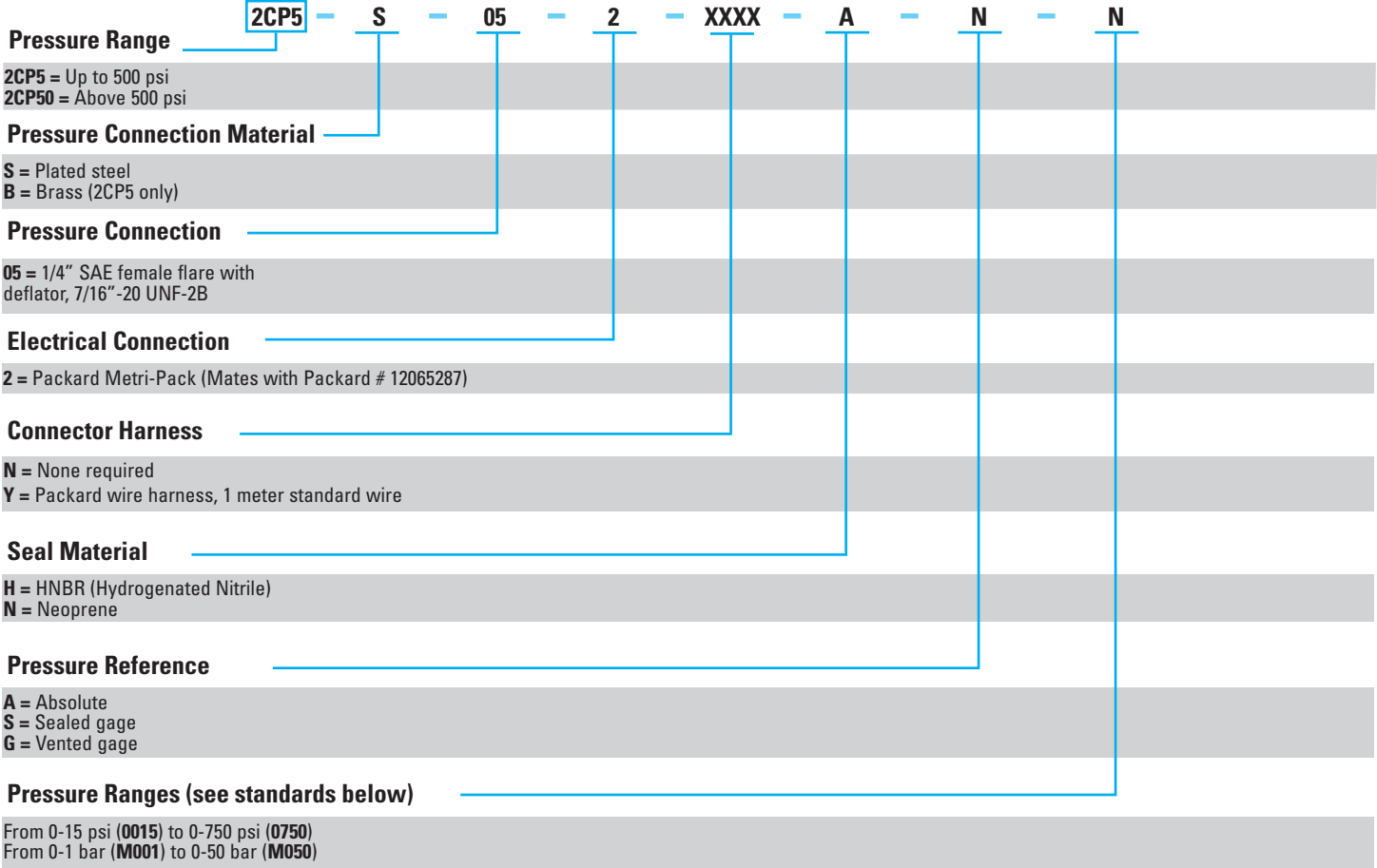

AGENCY APPROVALS & CERTIFICATIONS



UL recognized file #SA995
RoHS, REACH available

Sensata Technologies, Inc. ("Sensata") data sheets are solely intended to assist designers ("Buyers") who are developing systems that incorporate Sensata products (also referred to herein as "components"). Buyer understands and agrees that Buyer remains responsible for using its independent analysis, evaluation and judgment in designing Buyer's systems and products. Sensata data sheets have been created using standard laboratory conditions and engineering practices. Sensata has not conducted any testing other than that specifically described in the published documentation for a particular data sheet. Sensata may make corrections, enhancements, improvements and other changes to its data sheets or components without notice.

Buyers are authorized to use Sensata data sheets with the Sensata component(s) identified in each particular data sheet. HOWEVER, NO OTHER LICENSE, EXPRESS OR IMPLIED, BY ESTOPPEL OR OTHERWISE TO ANY OTHER SENSATA INTELLECTUAL PROPERTY RIGHT, AND NO LICENSE TO ANY THIRD PARTY TECHNOLOGY OR INTELLECTUAL PROPERTY RIGHT, IS GRANTED HEREIN. SENSATA DATA SHEETS ARE PROVIDED "AS IS". SENSATA MAKES NO WARRANTIES OR REPRESENTATIONS WITH REGARD TO THE DATA SHEETS OR USE OF THE DATA SHEETS, EXPRESS, IMPLIED OR STATUTORY, INCLUDING ACCURACY OR COMPLETENESS. SENSATA DISCLAIMS ANY WARRANTY OF TITLE AND ANY IMPLIED WARRANTIES OF MERCHANTABILITY, FITNESS FOR A PARTICULAR PURPOSE, QUIET ENJOYMENT, QUIET POSSESSION, AND NON-INFRINGEMENT OF ANY THIRD PARTY INTELLECTUAL PROPERTY RIGHTS WITH REGARD TO SENSATA DATA SHEETS OR USE THEREOF.

All products are sold subject to Sensata's terms and conditions of sale supplied at www.sensata.com SENSATA ASSUMES NO LIABILITY FOR APPLICATIONS ASSISTANCE OR THE DESIGN OF BUYERS' PRODUCTS. BUYER ACKNOWLEDGES AND AGREES THAT IT IS SOLELY RESPONSIBLE FOR COMPLIANCE WITH ALL LEGAL, REGULATORY AND SAFETY-RELATED REQUIREMENTS CONCERNING ITS PRODUCTS, AND ANY USE OF SENSATA COMPONENTS IN ITS APPLICATIONS, NOTWITHSTANDING ANY APPLICATIONS-RELATED INFORMATION OR SUPPORT THAT MAY BE PROVIDED BY SENSATA.

Mailing Address: Sensata Technologies, Inc., 529 Pleasant Street, Attleboro, MA 02703, USA.

CONTACT US

Americas
+1 (800) 350 2727
sensors@sensata.com
Europe, Middle East & Africa
+33 (3) 88 20 8080
position-info.eu@sensata.com
Asia Pacific
sales.isasia@list.sensata.com
China +86 (21) 2306 1500
Japan +81 (45) 277 7117
Korea +82 (31) 601 2004
India +91 (80) 67920890
Rest of Asia +886 (2) 27602006 ext 2808

Компания «Life Electronics» занимается поставками электронных компонентов импортного и отечественного производства от производителей и со складов крупных дистрибьюторов Европы, Америки и Азии.

С конца 2013 года компания активно расширяет линейку поставок компонентов по направлению коаксиальный кабель, кварцевые генераторы и конденсаторы (керамические, пленочные, электролитические), за счёт заключения дистрибьюторских договоров

Мы предлагаем:

- Конкурентоспособные цены и скидки постоянным клиентам.
- Специальные условия для постоянных клиентов.
- Подбор аналогов.
- Поставку компонентов в любых объемах, удовлетворяющих вашим потребностям.
- Приемлемые сроки поставки, возможна ускоренная поставка.
- Доставку товара в любую точку России и стран СНГ.
- Комплексную поставку.
- Работу по проектам и поставку образцов.
- Формирование склада под заказчика.
- Сертификаты соответствия на поставляемую продукцию (по желанию клиента).
- Тестирование поставляемой продукции.
- Поставку компонентов, требующих военную и космическую приемку.
- Входной контроль качества.
- Наличие сертификата ISO.

В составе нашей компании организован Конструкторский отдел, призванный помогать разработчикам, и инженерам.

Конструкторский отдел помогает осуществить:

- Регистрацию проекта у производителя компонентов.
- Техническую поддержку проекта.
- Защиту от снятия компонента с производства.
- Оценку стоимости проекта по компонентам.
- Изготовление тестовой платы монтаж и пусконаладочные работы.



Тел: +7 (812) 336 43 04 (многоканальный)

Email: org@lifeelectronics.ru