

## Si52147 EVALUATION BOARD USER'S GUIDE

### Description

The Si52147 is a nine port PCIe clock generator compliant to the PCIe Gen1, Gen2 and Gen3 standards. The Si52147 is a 48-pin QFN device that operates on a 3.3 V power supply and can be controlled using SMBus signals along with hardware control input pins. The differential outputs support spread spectrum and can be controlled through SSON input pin. The Si52147 needs a crystal or clock input of 25 MHz. The connections are described in this document.

### EVB Features

This document is intended to be used in conjunction with the Si52147 device and data sheet for the following tests:

- PCIe Gen1, Gen2, Gen3 compliancy
- Power consumption test
- Jitter performance
- Testing out I<sup>2</sup>C code for signal tuning
- In-system validation where SMA connectors are present

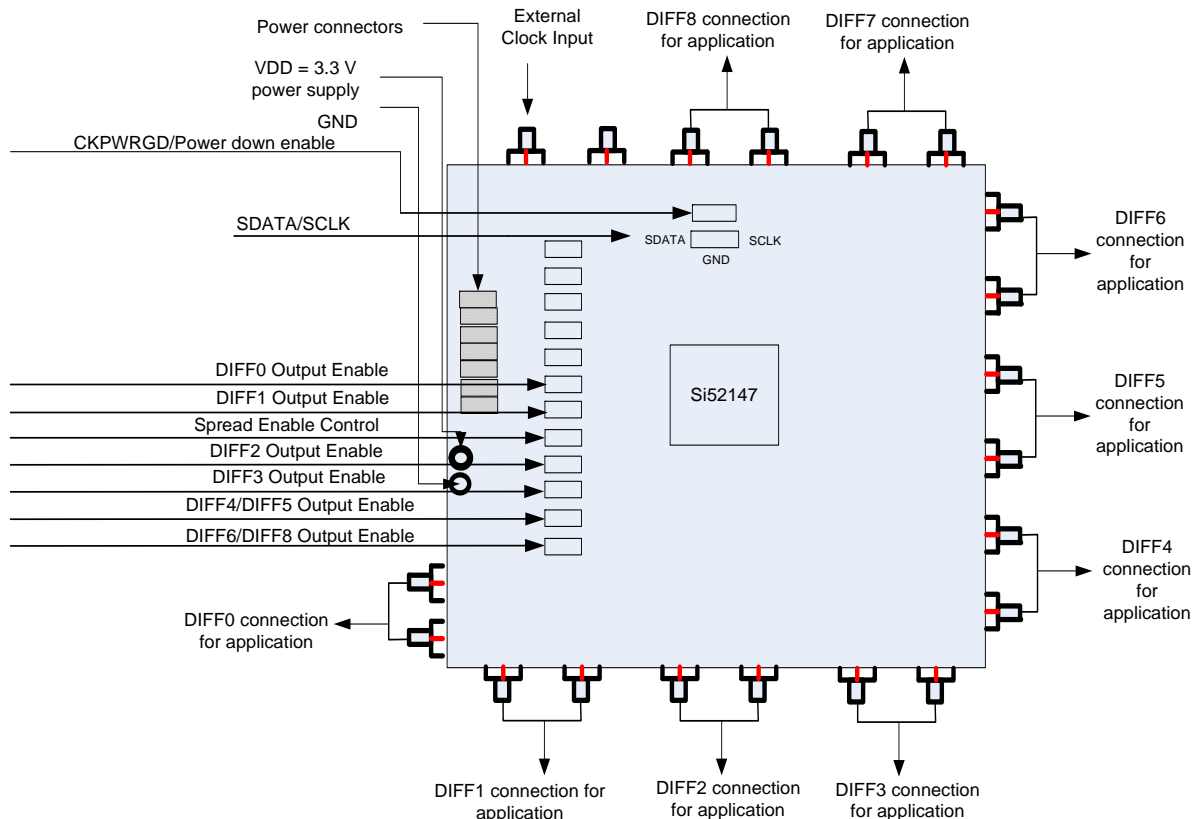

# Si52147-EVB

## 1. Front Panel

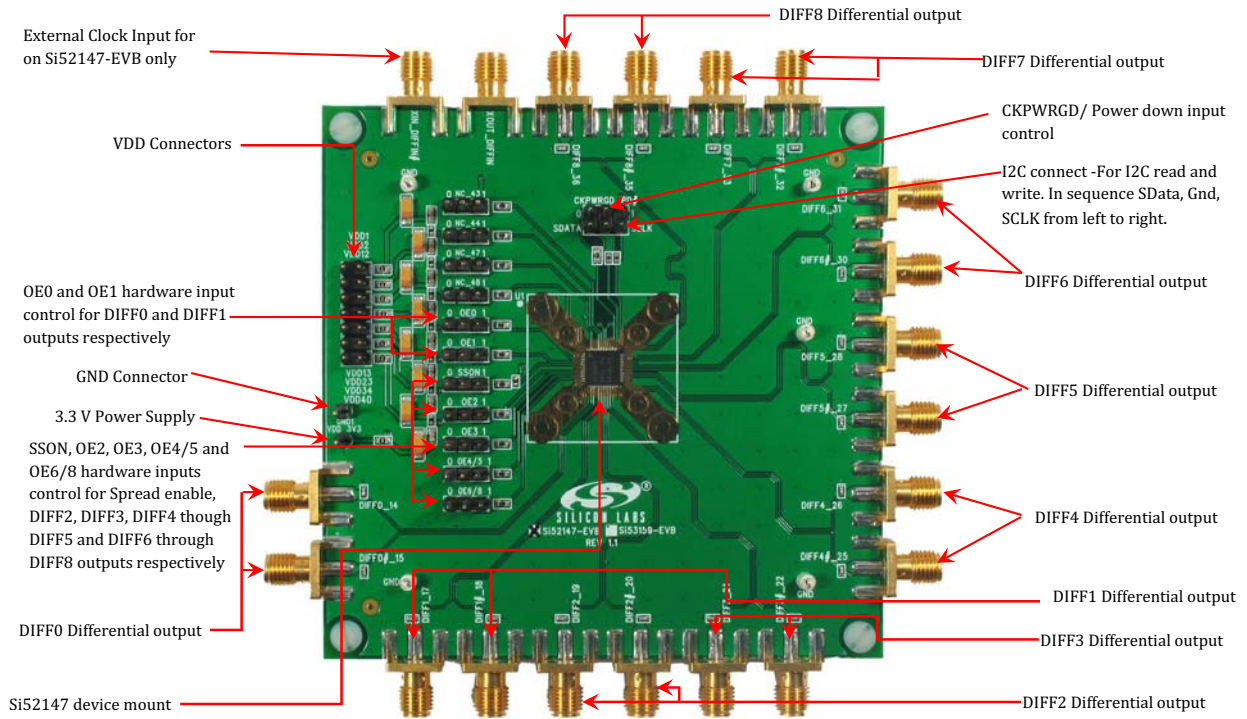

Figure 1. Evaluation Module Front Panel

Table 1. Input Jumper Settings

Jumper Label	Type	Description
OE0	I	<b>OE0, 3.3 V Input for Enabling DIFF0 Clock Output.</b> 1 = DIFF0 enabled, 0 = DIFF0 disabled.
OE1	I	<b>OE1, 3.3 V Input for Enabling DIFF1 Clock Output.</b> 1 = DIFF1 enabled, 0 = DIFF1 disabled.
OE2	I	<b>OE2, 3.3 V Input for Enabling DIFF2 Clock Output.</b> 1 = DIFF2 enabled, 0 = DIFF2 disabled.
OE3	I	<b>OE3, 3.3 V Input for Enabling DIFF3 Clock Output.</b> 1 = DIFF3 enabled, 0 = DIFF3 disabled.
OE4/5	I	<b>OE4/5, 3.3 V Input for Enabling DIFF4 and DIFF5 Clock Outputs.</b> 1 = DIFF4 & DIFF5 enabled, 0 = DIFF4 & DIFF5 disabled.
OE6/8	I	<b>OE6/8, 3.3 V Input for Enabling DIFF6, DIFF7 and DIFF8 Clock Outputs.</b> 1 = DIFF6, DIFF7 & DIFF8 enabled, 0 = DIFF6, DIFF7 & DIFF8 disabled.
CLKPWGD/ $\overline{\text{PD}}$	I	<b>3.3 V LVTTTL Input.</b> After CLKPWGD (active high) assertion, this pin becomes a real-time input for asserting power down (active low).

Table 1. Input Jumper Settings (Continued)

SSON	I	<b>SSON Input, 3.3 V-Tolerant Active Input for Spread selection on the Output.</b> Internal 100 k $\Omega$ pulldown. 1 = -0.5% Spread enabled, 0 = Spread disabled.
SDATA	I/O	<b>SMBus-Compatible SDATA.</b>
SCLK	I	<b>SMBus-Compatible SCLOCK.</b>

Table 2. Spread Selection

SSON	Frequency (MHz)	Spread (%)	Note
0	100.00	OFF	Default Value for SSON=0
1	100.00	-0.5	

# Si52147-EVB

## 1.1. Generating DIFF Outputs from the Si52147

Upon power-on of the device, if the input pins are left floating, by default all DIFF outputs DIFF[0:8] are ON with 100 MHz and with spread spectrum disabled. The input pin headers have clear indication of jumper settings for setting logic low (0) and high (1) as shown below, the jumper placed on middle and left pin will set input OE0 to LOW; and jumper placed on middle and right pin will set input OE0 to high.

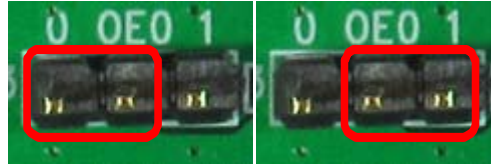

The output enable pins can be changed on the fly to observe outputs stopped cleanly. To enable the spread spectrum, the SSON input needs to change from a logic level low to high. Input functionality is explained in detail below.

### 1.1.1. SSON Input

Apply the appropriate logic level to SSON input to achieve clock frequency selection. When the SSON is high, -0.5% down spread is enabled on all differential outputs with a saw-tooth spread profile. When the SSON is low, spread profile is disabled.

### 1.1.2. OE [0:8] Input

The output enable pins can change on the fly when the device is on. Deasserting (valid low) results in corresponding DIFF output to be stopped after their next transition with final state low/low. Asserting (valid high) results in corresponding output that was stopped are to resume normal operation in a glitch-free manner.

Each of the hardware OE [0:8] pins are mapped via I<sup>2</sup>C to control bit in Control register. The hardware pin and the Register Control Bit both need to be high to enable the output. Both of these form an “AND” function to disable or enable the DIFF output. The DIFF outputs and their corresponding I<sup>2</sup>C control bits and hardware pins are listed in Table 3.

**Table 3. Output Enable Control**

I <sup>2</sup> C Control Bit	Output	Hardware Control Input
Byte1 [bit 4]	DIFF0	OE0
Byte1 [bit 2]	DIFF1	OE1
Byte2 [bit 1]	DIFF2	OE2
Byte2 [bit 0]	DIFF3	OE3
Byte1 [bit 7]	DIFF4	OE4/5
Byte1 [bit 6]	DIFF5	OE4/5
Byte2 [bit 5]	DIFF6	OE6/8
Byte2 [bit 4]	DIFF7	OE6/8
Byte2 [bit 3]	DIFF8	OE6/8

## 2. Schematics

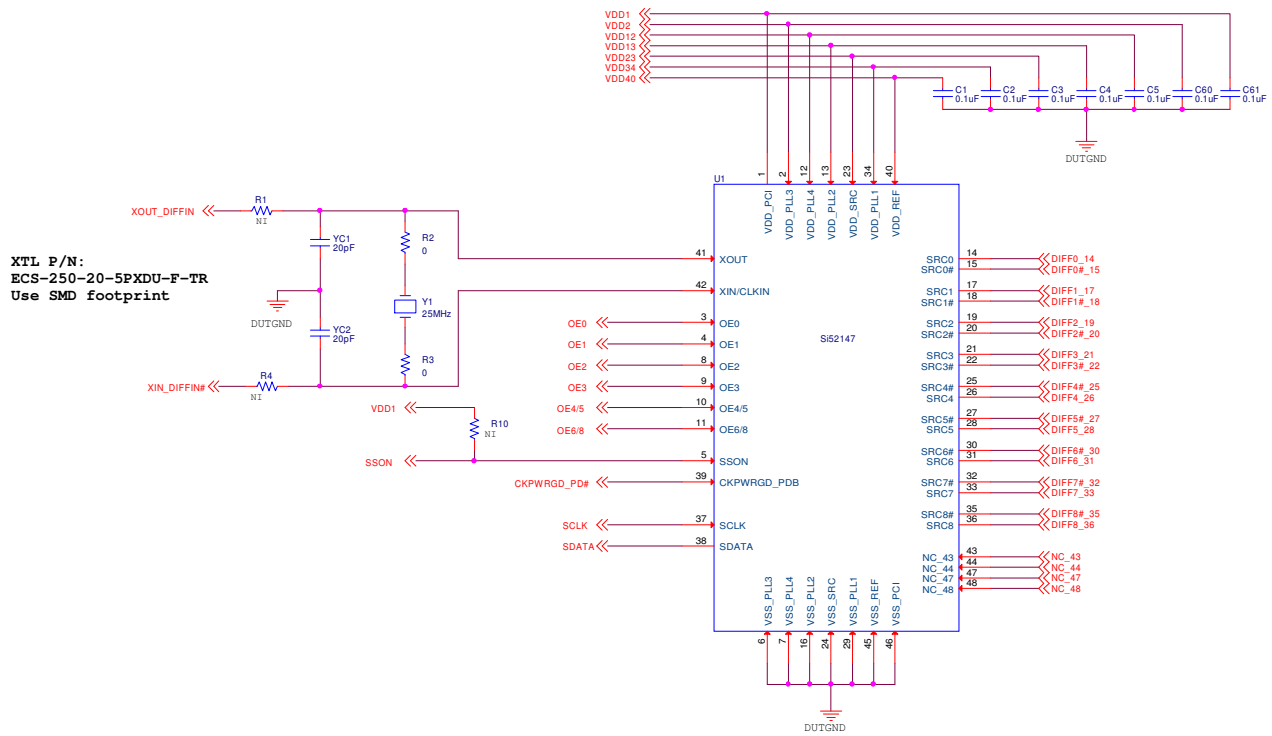

Figure 2. QFN-48 Device Connection

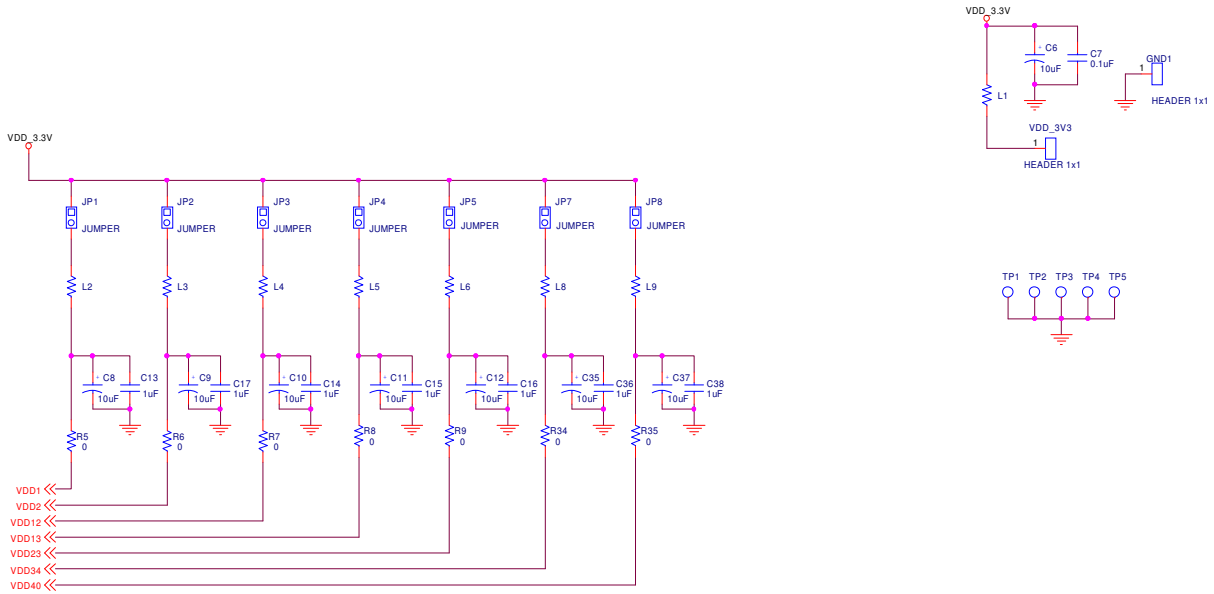

Figure 3. Device Power Supply

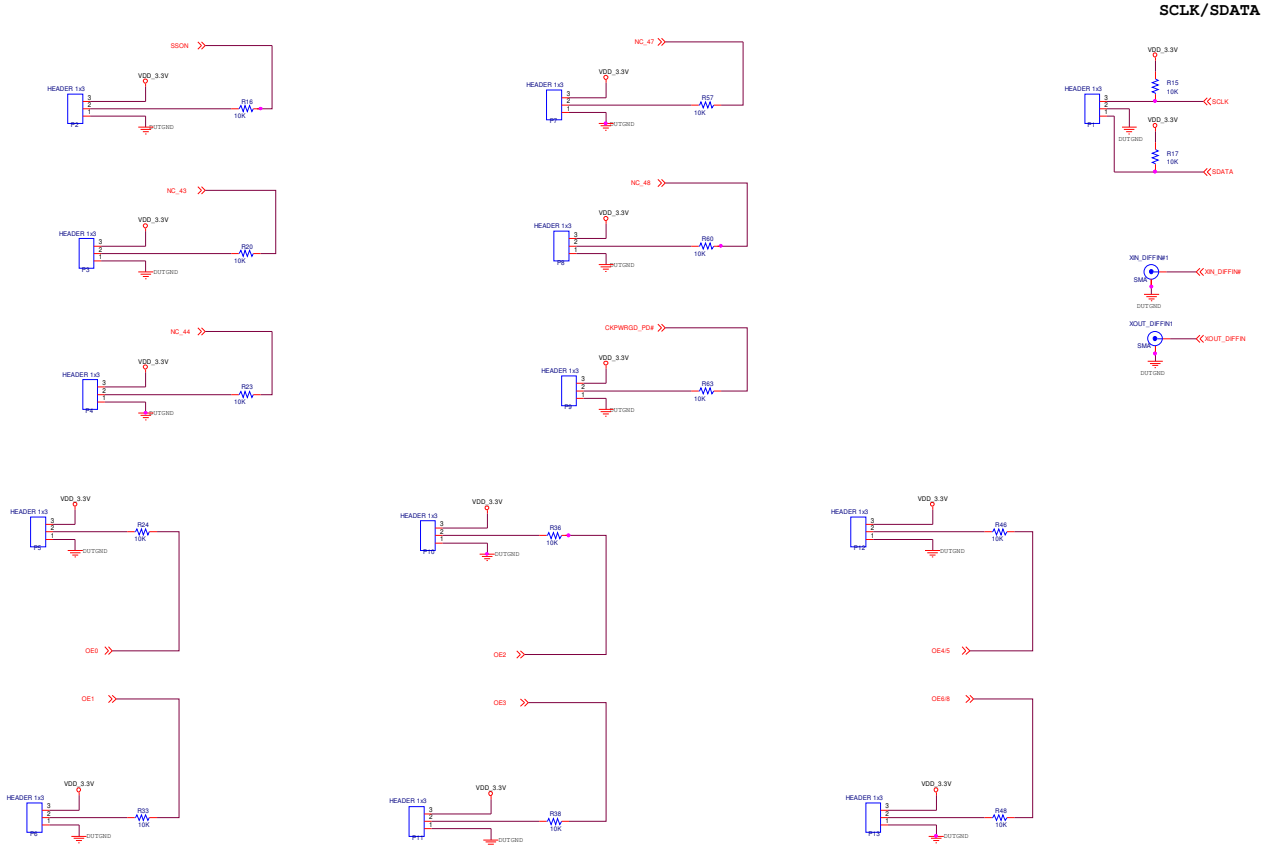

Figure 4. Clock and Control Signals

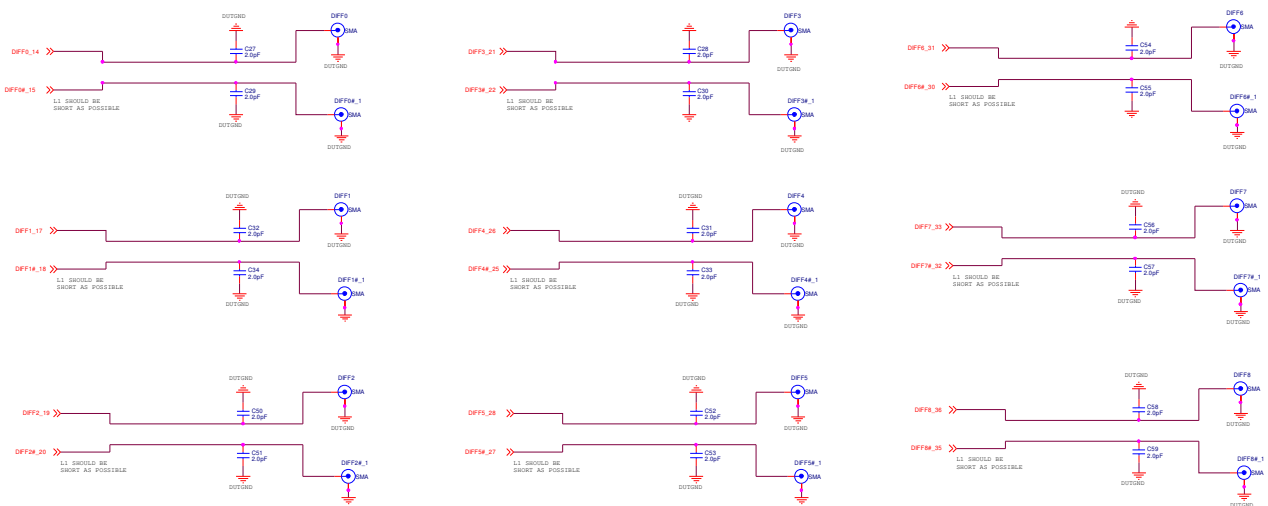

Figure 5. Differential Clock Signals

**NOTES:**

## CONTACT INFORMATION

Silicon Laboratories Inc.  
400 West Cesar Chavez  
Austin, TX 78701  
Tel: 1+(512) 416-8500  
Fax: 1+(512) 416-9669  
Toll Free: 1+(877) 444-3032

Please visit the Silicon Labs Technical Support web page:  
<https://www.silabs.com/support/pages/contacttechnicalsupport.aspx>  
and register to submit a technical support request.

The information in this document is believed to be accurate in all respects at the time of publication but is subject to change without notice. Silicon Laboratories assumes no responsibility for errors and omissions, and disclaims responsibility for any consequences resulting from the use of information included herein. Additionally, Silicon Laboratories assumes no responsibility for the functioning of undescribed features or parameters. Silicon Laboratories reserves the right to make changes without further notice. Silicon Laboratories makes no warranty, representation or guarantee regarding the suitability of its products for any particular purpose, nor does Silicon Laboratories assume any liability arising out of the application or use of any product or circuit, and specifically disclaims any and all liability, including without limitation consequential or incidental damages. Silicon Laboratories products are not designed, intended, or authorized for use in applications intended to support or sustain life, or for any other application in which the failure of the Silicon Laboratories product could create a situation where personal injury or death may occur. Should Buyer purchase or use Silicon Laboratories products for any such unintended or unauthorized application, Buyer shall indemnify and hold Silicon Laboratories harmless against all claims and damages.

Silicon Laboratories and Silicon Labs are trademarks of Silicon Laboratories Inc.  
Other products or brandnames mentioned herein are trademarks or registered trademarks of their respective holders.



Компания «Life Electronics» занимается поставками электронных компонентов импортного и отечественного производства от производителей и со складов крупных дистрибьюторов Европы, Америки и Азии.

С конца 2013 года компания активно расширяет линейку поставок компонентов по направлению коаксиальный кабель, кварцевые генераторы и конденсаторы (керамические, пленочные, электролитические), за счёт заключения дистрибьюторских договоров

Мы предлагаем:

- Конкурентоспособные цены и скидки постоянным клиентам.
- Специальные условия для постоянных клиентов.
- Подбор аналогов.
- Поставку компонентов в любых объемах, удовлетворяющих вашим потребностям.
- Приемлемые сроки поставки, возможна ускоренная поставка.
- Доставку товара в любую точку России и стран СНГ.
- Комплексную поставку.
- Работу по проектам и поставку образцов.
- Формирование склада под заказчика.
- Сертификаты соответствия на поставляемую продукцию (по желанию клиента).
- Тестирование поставляемой продукции.
- Поставку компонентов, требующих военную и космическую приемку.
- Входной контроль качества.
- Наличие сертификата ISO.

В составе нашей компании организован Конструкторский отдел, призванный помогать разработчикам, и инженерам.

Конструкторский отдел помогает осуществить:

- Регистрацию проекта у производителя компонентов.
- Техническую поддержку проекта.
- Защиту от снятия компонента с производства.
- Оценку стоимости проекта по компонентам.
- Изготовление тестовой платы монтаж и пусконаладочные работы.



Тел: +7 (812) 336 43 04 (многоканальный)

Email: [org@lifeelectronics.ru](mailto:org@lifeelectronics.ru)