

MC14541B

Programmable Timer

The MC14541B programmable timer consists of a 16-stage binary counter, an integrated oscillator for use with an external capacitor and two resistors, an automatic power-on reset circuit, and output control logic.

Timing is initialized by turning on power, whereupon the power-on reset is enabled and initializes the counter, within the specified V_{DD} range. With the power already on, an external reset pulse can be applied. Upon release of the initial reset command, the oscillator will oscillate with a frequency determined by the external RC network. The 16-stage counter divides the oscillator frequency (f_{osc}) with the n^{th} stage frequency being $f_{osc}/2^n$.

Features

- Available Outputs 2^8 , 2^{10} , 2^{13} or 2^{16}
- Increments on Positive Edge Clock Transitions
- Built-in Low Power RC Oscillator ($\pm 2\%$ accuracy over temperature range and $\pm 20\%$ supply and $\pm 3\%$ over processing at < 10 kHz)
- Oscillator May Be Bypassed if External Clock Is Available (Apply external clock to Pin 3)
- External Master Reset Totally Independent of Automatic Reset Operation
- Operates as 2^n Frequency Divider or Single Transition Timer
- Q/\bar{Q} Select Provides Output Logic Level Flexibility
- Reset (auto or master) Disables Oscillator During Resetting to Provide No Active Power Dissipation
- Clock Conditioning Circuit Permits Operation with Very Slow Clock Rise and Fall Times
- Automatic Reset Initializes All Counters On Power Up
- Supply Voltage Range = 3.0 Vdc to 18 Vdc with Auto Reset Disabled (Pin 5 = V_{DD})
= 8.5 Vdc to 18 Vdc with Auto Reset Enabled (Pin 5 = V_{SS})
- Pb-Free Packages are Available

PIN ASSIGNMENT

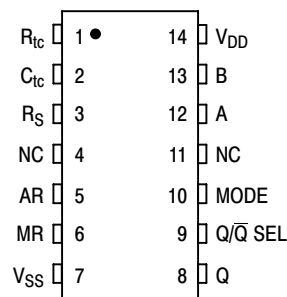

NC = NO CONNECTION



ON Semiconductor®

<http://onsemi.com>

MARKING DIAGRAMS

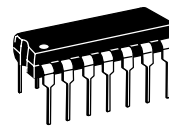

PDIP-14
P SUFFIX
CASE 646

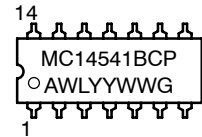

SOIC-14
D SUFFIX
CASE 751A

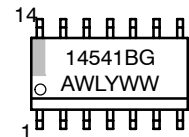

TSSOP-14
DT SUFFIX
CASE 948G

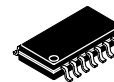
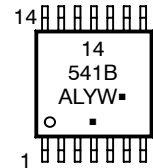

SOEIAJ-14
F SUFFIX
CASE 965

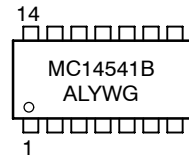

A = Assembly Location
WL, L = Wafer Lot
YY, Y = Year
WW, W = Work Week
G or ■ = Pb-Free Package
(Note: Microdot may be in either location)

ORDERING INFORMATION

See detailed ordering and shipping information in the package dimensions section on page 2 of this data sheet.

MC14541B

MAXIMUM RATINGS (Voltages Referenced to V_{SS})

Symbol	Parameter	Value	Unit
V_{DD}	DC Supply Voltage Range	-0.5 to +18.0	V
V_{in}, V_{out}	Input or Output Voltage Range, (DC or Transient)	-0.5 to $V_{DD} + 0.5$	V
I_{in}	Input Current (DC or Transient)	± 10 (per Pin)	mA
I_{out}	Output Current (DC or Transient)	± 45 (per Pin)	mA
P_D	Power Dissipation, per Package (Note 1)	500	mW
T_A	Ambient Temperature Range	-55 to +125	°C
T_{stg}	Storage Temperature Range	-65 to +150	°C
T_L	Lead Temperature, (8-Second Soldering)	260	°C

Stresses exceeding Maximum Ratings may damage the device. Maximum Ratings are stress ratings only. Functional operation above the Recommended Operating Conditions is not implied. Extended exposure to stresses above the Recommended Operating Conditions may affect device reliability.

1. Temperature Derating:

Plastic "P and D/DW" Packages: - 7.0 mW/°C From 65°C To 125°C

ORDERING INFORMATION

Device	Package	Shipping [†]
MC14541BCP	PDIP-14	25 Units / Rail
MC14541BCPG	PDIP-14 (Pb-Free)	
MC14541BD	SOIC-14	55 Units / Rail
MC14541BDG	SOIC-14 (Pb-Free)	
MC14541BDR2	SOIC-14	2500 / Tape & Reel
MC14541BDR2G	SOIC-14 (Pb-Free)	
MC14541BDTR2	TSSOP-14*	
MC14541BDTR2G	TSSOP-14*	
MC14541BF	SOEIAJ-14	50 Units / Rail
MC14541BFG	SOEIAJ-14 (Pb-Free)	
MC14541BFEL	SOEIAJ-14	2000 / Tape & Reel
MC14541BFELG	SOEIAJ-14 (Pb-Free)	

[†]For information on tape and reel specifications, including part orientation and tape sizes, please refer to our Tape and Reel Packaging Specifications Brochure, BRD8011/D.

*This package is inherently Pb-Free.

MC14541B

ELECTRICAL CHARACTERISTICS (Voltages Referenced to V_{SS})

Characteristic	Symbol	V _{DD} Vdc	- 55° C		25° C			125° C		Unit
			Min	Max	Min	Typ (Note 2)	Max	Min	Max	
Output Voltage V _{in} = V _{DD} or 0 V _{in} = 0 or V _{DD}	"0" Level V _{OL}	5.0	-	0.05	-	0	0.05	-	0.05	Vdc
		10	-	0.05	-	0	0.05	-	0.05	
		15	-	0.05	-	0	0.05	-	0.05	
	"1" Level V _{OH}	5.0	4.95	-	4.95	5.0	-	4.95	-	Vdc
		10	9.95	-	9.95	10	-	9.95	-	
		15	14.95	-	14.95	15	-	14.95	-	
Input Voltage "0" Level (V _O = 4.5 or 0.5 Vdc) (V _O = 9.0 or 1.0 Vdc) (V _O = 13.5 or 1.5 Vdc) "1" Level (V _O = 0.5 or 4.5 Vdc) (V _O = 1.0 or 9.0 Vdc) (V _O = 1.5 or 13.5 Vdc)	V _{IL}	5.0	-	1.5	-	2.25	1.5	-	1.5	Vdc
		10	-	3.0	-	4.50	3.0	-	3.0	
		15	-	4.0	-	6.75	4.0	-	4.0	
	V _{IH}	5.0	3.5	-	3.5	2.75	-	3.5	-	Vdc
		10	7.0	-	7.0	5.50	-	7.0	-	
		15	11	-	11	8.25	-	11	-	
Output Drive Current (V _{OH} = 2.5 Vdc) (V _{OH} = 9.5 Vdc) (V _{OH} = 13.5 Vdc) (V _{OL} = 0.4 Vdc) (V _{OL} = 0.5 Vdc) (V _{OL} = 1.5 Vdc)	Source I _{OH}	5.0	-7.96	-	-6.42	-12.83	-	-4.49	-	mAdc
		10	-4.19	-	-3.38	-6.75	-	-2.37	-	
		15	-16.3	-	-13.2	-26.33	-	-9.24	-	
	Sink I _{OL}	5.0	1.93	-	1.56	3.12	-	1.09	-	mAdc
		10	4.96	-	4.0	8.0	-	2.8	-	
		15	19.3	-	15.6	31.2	-	10.9	-	
Input Current	I _{in}	15	-	± 0.1	-	± 0.00001	± 0.1	-	± 1.0	μAdc
Input Capacitance (V _{in} = 0)	C _{in}	-	-	-	-	5.0	7.5	-	-	pF
Quiescent Current (Pin 5 is High) Auto Reset Disabled	I _{DD}	5.0	-	5.0	-	0.005	5.0	-	150	μAdc
		10	-	10	-	0.010	10	-	300	
		15	-	20	-	0.015	20	-	600	
Auto Reset Quiescent Current (Pin 5 is low)	I _{DDR}	10	-	250	-	30	250	-	1500	μAdc
		15	-	500	-	82	500	-	2000	
Supply Current (Notes 3 & 4) (Dynamic plus Quiescent)	I _D	5.0	I _D = (0.4 μA/kHz) f + I _{DD}							μAdc
10	I _D = (0.8 μA/kHz) f + I _{DD}									
15	I _D = (1.2 μA/kHz) f + I _{DD}									

2. Data labelled "Typ" is not to be used for design purposes but is intended as an indication of the IC's potential performance.

3. The formulas given are for the typical characteristics only at 25° C.

4. When using the on chip oscillator the total supply current (in μAdc) becomes: I_T = I_D + 2 C_{tc} V_{DD} f × 10⁻³ where I_D is in μA, C_{tc} is in pF, V_{DD} in Volts DC, and f in kHz. (see Fig. 3) Dissipation during power-on with automatic reset enabled is typically 50 μA @ V_{DD} = 10 Vdc.

MC14541B

SWITCHING CHARACTERISTICS (Note 5) ($C_L = 50 \text{ pF}$, $T_A = 25^\circ\text{C}$)

Characteristic	Symbol	V_{DD}	Min	Typ (Note 6)	Max	Unit
Output Rise and Fall Time $t_{TLH}, t_{THL} = (1.5 \text{ ns/pF}) C_L + 25 \text{ ns}$ $t_{TLH}, t_{THL} = (0.75 \text{ ns/pF}) C_L + 12.5 \text{ ns}$ $t_{TLH}, t_{THL} = (0.55 \text{ ns/pF}) C_L + 9.5 \text{ ns}$	t_{TLH} , t_{THL}	5.0 10 15	– – –	100 50 40	200 100 80	ns
Propagation Delay, Clock to Q (2^8 Output) $t_{PLH}, t_{PHL} = (1.7 \text{ ns/pF}) C_L + 3415 \text{ ns}$ $t_{PLH}, t_{PHL} = (0.66 \text{ ns/pF}) C_L + 1217 \text{ ns}$ $t_{PLH}, t_{PHL} = (0.5 \text{ ns/pF}) C_L + 875 \text{ ns}$	t_{PLH} t_{PHL}	5.0 10 15	– – –	3.5 1.25 0.9	10.5 3.8 2.9	μs
Propagation Delay, Clock to Q (2^{16} Output) $t_{PHL}, t_{PLH} = (1.7 \text{ ns/pF}) C_L + 5915 \text{ ns}$ $t_{PHL}, t_{PLH} = (0.66 \text{ ns/pF}) C_L + 3467 \text{ ns}$ $t_{PHL}, t_{PLH} = (0.5 \text{ ns/pF}) C_L + 2475 \text{ ns}$	t_{PHL} t_{PLH}	5.0 10 15	– – –	6.0 3.5 2.5	18 10 7.5	μs
Clock Pulse Width	$t_{WH(cl)}$	5.0 10 15	900 300 225	300 100 85	– – –	ns
Clock Pulse Frequency (50% Duty Cycle)	f_{cl}	5.0 10 15	– – –	1.5 4.0 6.0	0.75 2.0 3.0	MHz
MR Pulse Width	$t_{WH(R)}$	5.0 10 15	900 300 225	300 100 85	– – –	ns
Master Reset Removal Time	t_{rem}	5.0 10 15	420 200 200	210 100 100	– – –	ns

5. The formulas given are for the typical characteristics only at 25°C .

6. Data labelled "Typ" is not to be used for design purposes but is intended as an indication of the IC's potential performance.

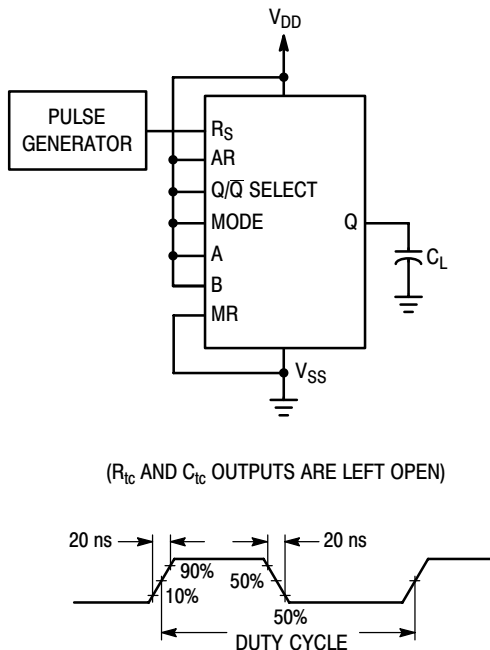

Figure 1. Power Dissipation Test Circuit and Waveform

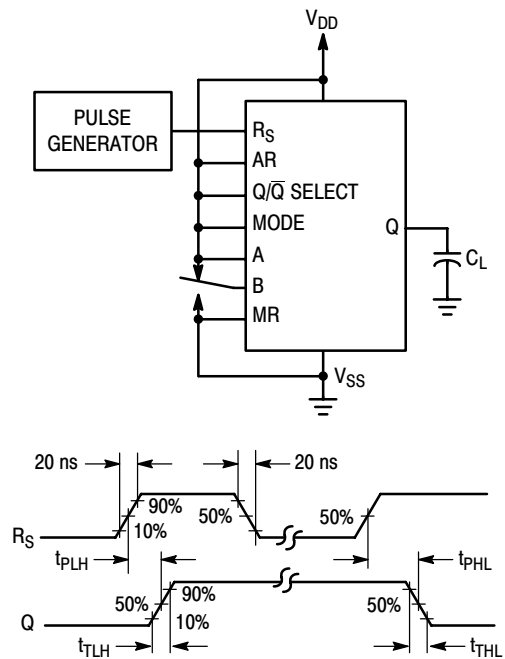
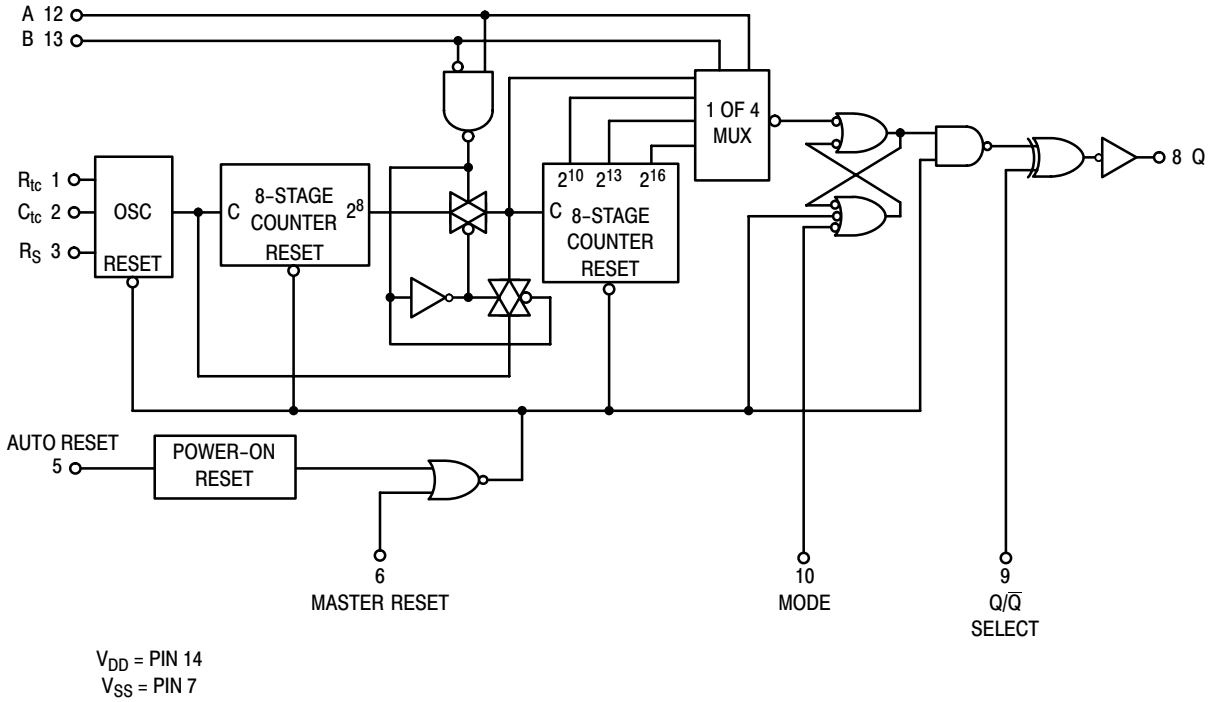

Figure 2. Switching Time Test Circuit and Waveforms

MC14541B

EXPANDED BLOCK DIAGRAM



FREQUENCY SELECTION TABLE

A	B	Number of Counter Stages n	Count 2^n
0	0	13	8192
0	1	10	1024
1	0	8	256
1	1	16	65536

TRUTH TABLE

Pin	State	
	0	1
Auto Reset, 5	Auto Reset Operating	Auto Reset Disabled
Master Reset, 6	Timer Operational	Master Reset On
Q/\bar{Q} , 9	Output Initially Low After Reset	Output Initially High After Reset
Mode, 10	Single Cycle Mode	Recycle Mode

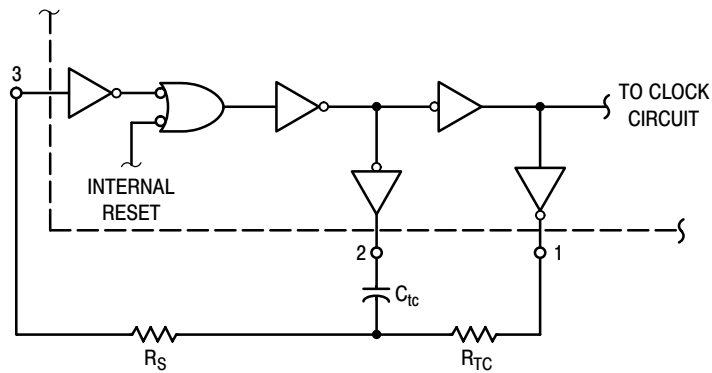

Figure 3. Oscillator Circuit Using RC Configuration

TYPICAL RC OSCILLATOR CHARACTERISTICS

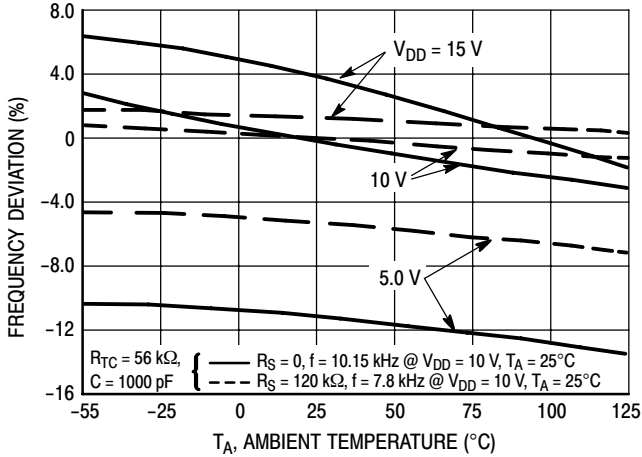

Figure 4. RC Oscillator Stability

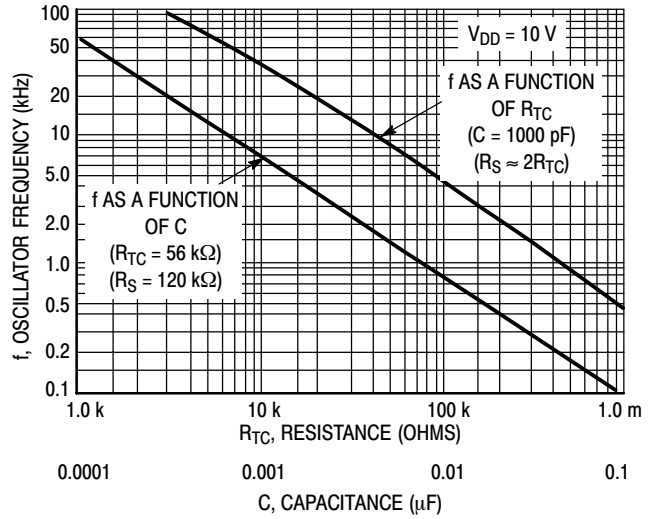

Figure 5. RC Oscillator Frequency as a Function of R_{tc} and C_{tc}

OPERATING CHARACTERISTICS

With Auto Reset pin set to a “0” the counter circuit is initialized by turning on power. Or with power already on, the counter circuit is reset when the Master Reset pin is set to a “1”. Both types of reset will result in synchronously resetting all counter stages independent of counter state. Auto Reset pin when set to a “1” provides a low power operation.

The RC oscillator as shown in Figure 3 will oscillate with a frequency determined by the external RC network i.e.,

$$f = \frac{1}{2.3 R_{tc} C_{tc}} \quad \text{if } (1 \text{ kHz} \leq f \leq 100 \text{ kHz})$$

and $R_S \approx 2 R_{tc}$ where $R_S \geq 10 \text{ k}\Omega$

The time select inputs (A and B) provide a two-bit address to output any one of four counter stages (2^8 , 2^{10} , 2^{13} and 2^{16}). The 2^n counts as shown in the Frequency Selection Table represents the Q output of the N^{th} stage of the counter. When A is “1”, 2^{16} is selected for both states of B. However,

when B is “0”, normal counting is interrupted and the 9th counter stage receives its clock directly from the oscillator (i.e., effectively outputting 2^8).

The Q/\bar{Q} select output control pin provides for a choice of output level. When the counter is in a reset condition and Q/\bar{Q} select pin is set to a “0” the Q output is a “0”, correspondingly when Q/\bar{Q} select pin is set to a “1” the Q output is a “1”.

When the mode control pin is set to a “1”, the selected count is continually transmitted to the output. But, with mode pin “0” and after a reset condition the R_S flip-flop (see Expanded Block Diagram) resets, counting commences, and after 2^{n-1} counts the R_S flip-flop sets which causes the output to change state. Hence, after another 2^{n-1} counts the output will not change. Thus, a Master Reset pulse must be applied or a change in the mode pin level is required to reset the single cycle operation.

DIGITAL TIMER APPLICATION

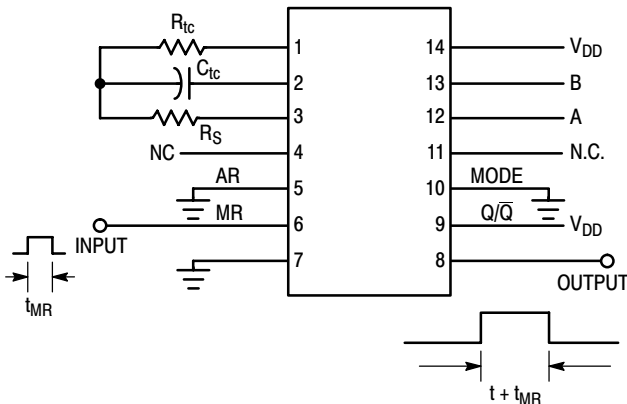

When Master Reset (MR) receives a positive pulse, the internal counters and latch are reset. The Q output goes high and remains high until the selected (via A and B) number of clock pulses are counted, the Q output then goes low and remains low until another input pulse is received.

This “one shot” is fully retriggerable and as accurate as the input frequency. An external clock can be used (pin 3 is the clock input, pins 1 and 2 are outputs) if additional accuracy is needed.

Notice that a setup time equal to the desired pulse width output is required immediately following initial power up, during which time Q output will be high.

MC14541B

PACKAGE DIMENSIONS

PDIP-14
CASE 646-06
ISSUE P

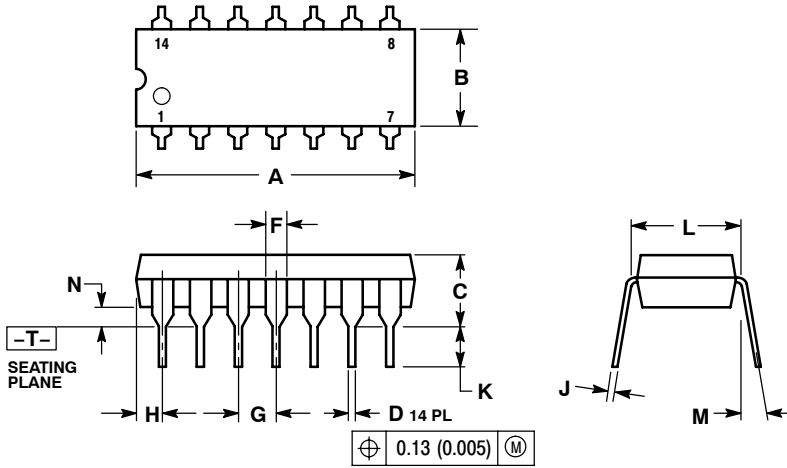

NOTES:

1. DIMENSIONING AND TOLERANCING PER ANSI Y14.5M, 1982.
2. CONTROLLING DIMENSION: INCH.
3. DIMENSION L TO CENTER OF LEADS WHEN FORMED PARALLEL.
4. DIMENSION B DOES NOT INCLUDE MOLD FLASH.
5. ROUNDED CORNERS OPTIONAL.

DIM	INCHES		MILLIMETERS	
	MIN	MAX	MIN	MAX
A	0.715	0.770	18.16	19.56
B	0.240	0.260	6.10	6.60
C	0.145	0.185	3.69	4.69
D	0.015	0.021	0.38	0.53
F	0.040	0.070	1.02	1.78
G	0.100 BSC		2.54 BSC	
H	0.052	0.095	1.32	2.41
J	0.008	0.015	0.20	0.38
K	0.115	0.135	2.92	3.43
L	0.290	0.310	7.37	7.87
M	---	10°	---	10°
N	0.015	0.039	0.38	1.01

MC14541B

SOIC-14
CASE 751A-03
ISSUE H

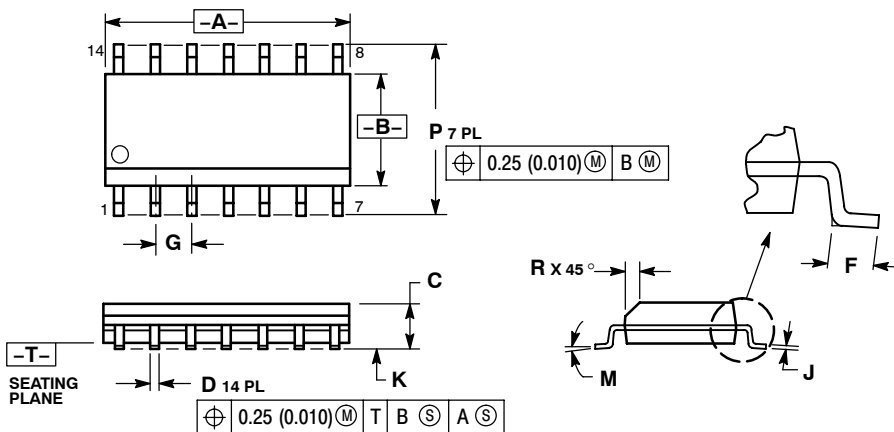

NOTES:

1. DIMENSIONING AND TOLERANCING PER ANSI Y14.5M, 1982.
2. CONTROLLING DIMENSION: MILLIMETER.
3. DIMENSIONS A AND B DO NOT INCLUDE MOLD PROTRUSION.
4. MAXIMUM MOLD PROTRUSION 0.15 (0.006) PER SIDE.
5. DIMENSION D DOES NOT INCLUDE DAMBAR PROTRUSION. ALLOWABLE DAMBAR PROTRUSION SHALL BE 0.127 (0.005) TOTAL IN EXCESS OF THE D DIMENSION AT MAXIMUM MATERIAL CONDITION.

DIM	MILLIMETERS		INCHES	
	MIN	MAX	MIN	MAX
A	8.55	8.75	0.337	0.344
B	3.80	4.00	0.150	0.157
C	1.35	1.75	0.054	0.068
D	0.35	0.49	0.014	0.019
F	0.40	1.25	0.016	0.049
G	1.27 BSC		0.050 BSC	
J	0.19	0.25	0.008	0.009
K	0.10	0.25	0.004	0.009
M	0°	7°	0°	7°
P	5.80	6.20	0.228	0.244
R	0.25	0.50	0.010	0.019

SOLDERING FOOTPRINT*

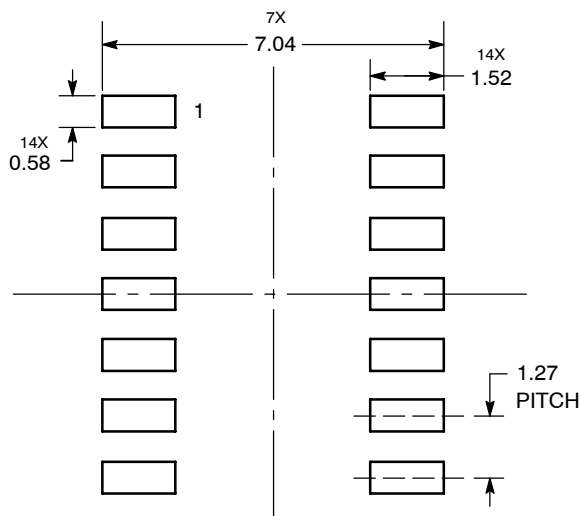

DIMENSIONS: MILLIMETERS

*For additional information on our Pb-Free strategy and soldering details, please download the ON Semiconductor Soldering and Mounting Techniques Reference Manual, SOLDERRM/D.

MC14541B

PACKAGE DIMENSIONS

SOEIAJ-14
CASE 965-01
ISSUE A

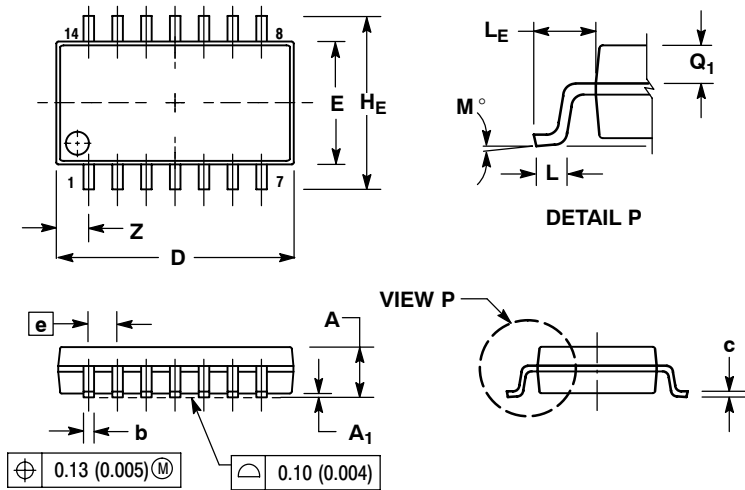

NOTES:

1. DIMENSIONING AND TOLERANCING PER ANSI Y14.5M, 1982.
2. CONTROLLING DIMENSION: MILLIMETER.
3. DIMENSIONS D AND E DO NOT INCLUDE MOLD FLASH OR PROTRUSIONS AND ARE MEASURED AT THE PARTING LINE. MOLD FLASH OR PROTRUSIONS SHALL NOT EXCEED 0.15 (0.006) PER SIDE.
4. TERMINAL NUMBERS ARE SHOWN FOR REFERENCE ONLY.
5. THE LEAD WIDTH DIMENSION (b) DOES NOT INCLUDE DAMBAR PROTRUSION. ALLOWABLE DAMBAR PROTRUSION SHALL BE 0.08 (0.003) TOTAL IN EXCESS OF THE LEAD WIDTH DIMENSION AT MAXIMUM MATERIAL CONDITION. DAMBAR CANNOT BE LOCATED ON THE LOWER RADIUS OR THE FOOT. MINIMUM SPACE BETWEEN PROTRUSIONS AND ADJACENT LEAD TO BE 0.46 (0.018).

DIM	MILLIMETERS		INCHES	
	MIN	MAX	MIN	MAX
A	---	2.05	---	0.081
A ₁	0.05	0.20	0.002	0.008
b	0.35	0.50	0.014	0.020
c	0.10	0.20	0.004	0.008
D	9.90	10.50	0.390	0.413
E	5.10	5.45	0.201	0.215
e	1.27 BSC		0.050 BSC	
H _E	7.40	8.20	0.291	0.323
0.50	0.50	0.85	0.020	0.033
L _E	1.10	1.50	0.043	0.059
M	0°	10°	0°	10°
Q ₁	0.70	0.90	0.028	0.035
Z	---	1.42	---	0.056

ON Semiconductor and are registered trademarks of Semiconductor Components Industries, LLC (SCILLC). SCILLC reserves the right to make changes without further notice to any products herein. SCILLC makes no warranty, representation or guarantee regarding the suitability of its products for any particular purpose, nor does SCILLC assume any liability arising out of the application or use of any product or circuit, and specifically disclaims any and all liability, including without limitation special, consequential or incidental damages. "Typical" parameters which may be provided in SCILLC data sheets and/or specifications can and do vary in different applications and actual performance may vary over time. All operating parameters, including "Typicals" must be validated for each customer application by customer's technical experts. SCILLC does not convey any license under its patent rights nor the rights of others. SCILLC products are not designed, intended, or authorized for use as components in systems intended for surgical implant into the body, or other applications intended to support or sustain life, or for any other application in which the failure of the SCILLC product could create a situation where personal injury or death may occur. Should Buyer purchase or use SCILLC products for any such unintended or unauthorized application, Buyer shall indemnify and hold SCILLC and its officers, employees, subsidiaries, affiliates, and distributors harmless against all claims, costs, damages, and expenses, and reasonable attorney fees arising out of, directly or indirectly, any claim of personal injury or death associated with such unintended or unauthorized use, even if such claim alleges that SCILLC was negligent regarding the design or manufacture of the part. SCILLC is an Equal Opportunity/Affirmative Action Employer. This literature is subject to all applicable copyright laws and is not for resale in any manner.

PUBLICATION ORDERING INFORMATION

LITERATURE FULFILLMENT:
Literature Distribution Center for ON Semiconductor
P.O. Box 5163, Denver, Colorado 80217 USA
Phone: 303-675-2175 or 800-344-3860 Toll Free USA/Canada
Fax: 303-675-2176 or 800-344-3867 Toll Free USA/Canada
Email: orderlit@onsemi.com

N. American Technical Support: 800-282-9855 Toll Free USA/Canada
Europe, Middle East and Africa Technical Support:
Phone: 421 33 790 2910
Japan Customer Focus Center
Phone: 81-3-5773-3850

ON Semiconductor Website: www.onsemi.com
Order Literature: <http://www.onsemi.com/orderlit>

For additional information, please contact your local Sales Representative

Компания «Life Electronics» занимается поставками электронных компонентов импортного и отечественного производства от производителей и со складов крупных дистрибьюторов Европы, Америки и Азии.

С конца 2013 года компания активно расширяет линейку поставок компонентов по направлению коаксиальный кабель, кварцевые генераторы и конденсаторы (керамические, пленочные, электролитические), за счёт заключения дистрибьюторских договоров

Мы предлагаем:

- Конкурентоспособные цены и скидки постоянным клиентам.
- Специальные условия для постоянных клиентов.
- Подбор аналогов.
- Поставку компонентов в любых объемах, удовлетворяющих вашим потребностям.
- Приемлемые сроки поставки, возможна ускоренная поставка.
- Доставку товара в любую точку России и стран СНГ.
- Комплексную поставку.
- Работу по проектам и поставку образцов.
- Формирование склада под заказчика.
- Сертификаты соответствия на поставляемую продукцию (по желанию клиента).
- Тестирование поставляемой продукции.
- Поставку компонентов, требующих военную и космическую приемку.
- Входной контроль качества.
- Наличие сертификата ISO.

В составе нашей компании организован Конструкторский отдел, призванный помогать разработчикам, и инженерам.

Конструкторский отдел помогает осуществить:

- Регистрацию проекта у производителя компонентов.
- Техническую поддержку проекта.
- Защиту от снятия компонента с производства.
- Оценку стоимости проекта по компонентам.
- Изготовление тестовой платы монтаж и пусконаладочные работы.



Тел: +7 (812) 336 43 04 (многоканальный)
Email: org@lifeelectronics.ru