

---

## Digitally Enhanced Power Analog Controller with Integrated Synchronous Driver

---

### Synchronous Buck Features:

- Input Voltage: 4.5V to 32V
- Output Voltage: 0.5V to 3.6V
  - Greater than 3.6V requires external divider
- Switching Frequency: 100 kHz to 1.6 MHz
- Quiescent Current: 5 mA Typical
- High-Drive:
  - +5V Gate Drive
  - 1A/2A Source Current
  - 1A/2A Sink Current
- Low-Drive:
  - +5V Gate Drive
  - 2A Source Current
  - 4A Sink Current
- Peak Current Mode Control
- Differential Remote Output Sense
- Multi-Phase Systems:
  - Master or Slave
  - Frequency Synchronized
  - Common Error Signal
- Multiple Output Systems:
  - Master or Slave
  - Frequency Synchronized
- Configurable Parameters:
  - Overcurrent Limit
  - Input Undervoltage Lockout
  - Output Overvoltage
  - Output Undervoltage
  - Internal Analog Compensation
  - Soft Start Profile
  - Synchronous Driver Dead Time
  - Switching Frequency
- Thermal Shutdown

### Microcontroller Features:

- Precision 8 MHz Internal Oscillator Block:
  - Factory Calibrated
- Interrupt Capable
  - Firmware
  - Interrupt-on-Change Pins
- Only 35 Instructions to Learn
- 4096 Words On-Chip Program Memory
- High Endurance Flash:
  - 100,000 write Flash Endurance
  - Flash Retention: >40 years
- Watchdog Timer (WDT) with Independent Oscillator for Reliable Operation
- Programmable Code Protection
- In-Circuit Debug (ICD) via Two Pins (**MCP19111**)
- In-Circuit Serial Programming™ (ICSP™) via Two Pins
- 11 I/O Pins and One Input-Only Pin (**MCP19110**)
  - Three Open-Drain Pins
- 14 I/O Pins and One Input-Only Pin (**MCP19111**)
  - Three Open-Drain Pins
- Analog-to-Digital Converter (ADC):
  - 10-bit Resolution
  - 12 Internal Channels
  - Eight External Channels
- Timer0: 8-bit Timer/Counter with 8-Bit Prescaler
- Enhanced Timer1:
  - 16-bit Timer/Counter with Prescaler
  - Two Selectable Clock Sources
- Timer2: 8-Bit Timer/Counter with Prescaler
  - 8-bit Period Register
- I<sup>2</sup>C™ Communication:
  - 7-bit Address Masking
  - Two Dedicated Address Registers
  - SMBus/PMBus™ Compatibility

# MCP19110/11

Pin Diagram – 24-Pin QFN (MCP19110)

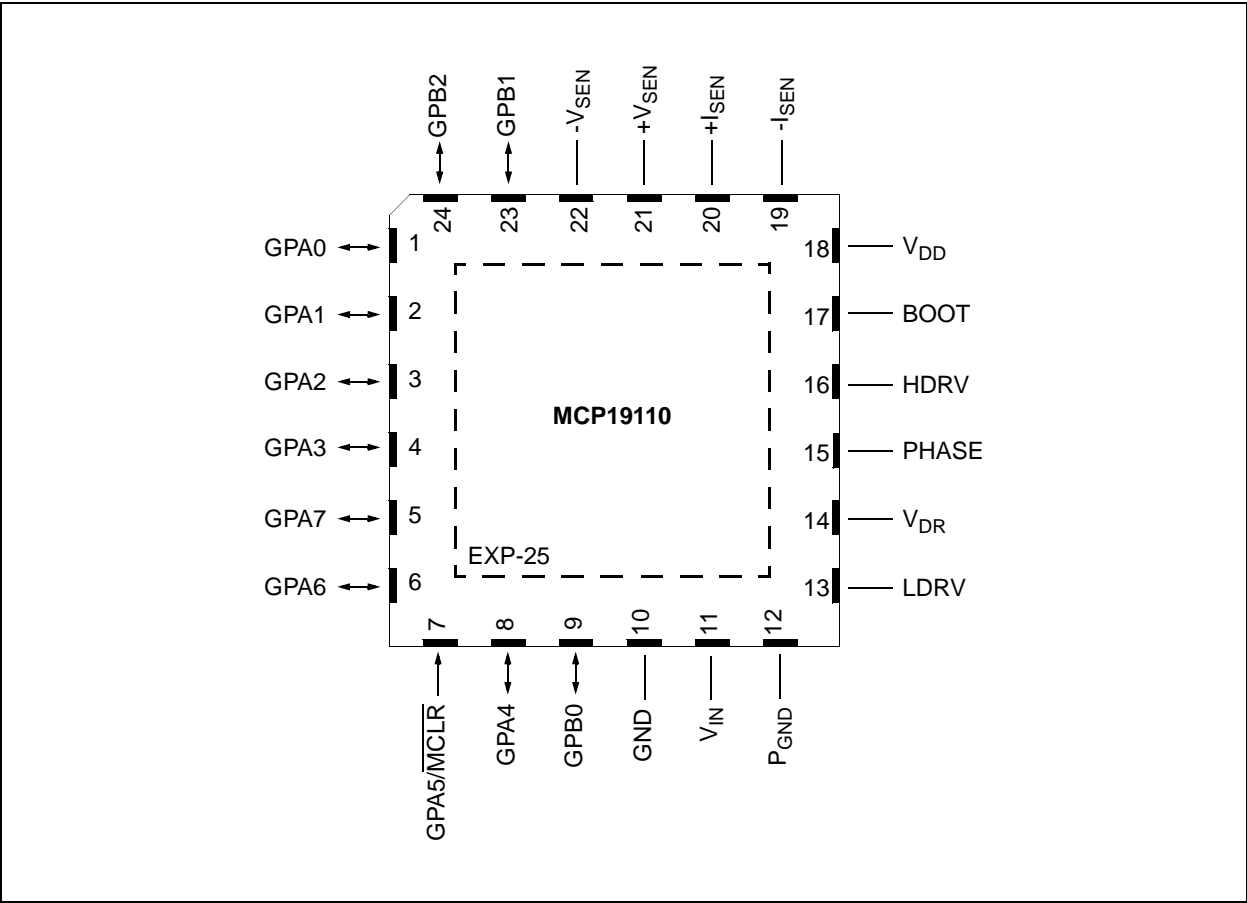

**TABLE 0-1: 24-PIN SUMMARY**

I/O	24-Pin QFN	ANSEL	A/D	Timers	MSSP	Interrupt	Pull-up	Basic	Additional
GPA0	1	Y	AN0	—	—	IOC	Y	—	Analog Debug Output <sup>(1)</sup>
GPA1	2	Y	AN1	—	—	IOC	Y	—	Sync. Signal In/Out <sup>(2, 3)</sup>
GPA2	3	Y	AN2	TOCKI	—	IOC INT	Y	—	—
GPA3	5	Y	AN3	—	—	IOC	Y	—	—
GPA4	8	N	—	—	—	IOC	N	—	—
GPA5	7	N	—	—	—	IOC <sup>(4)</sup>	Y <sup>(5)</sup>	$\overline{\text{MCLR}}$	—
GPA6	6	N	—	—	—	IOC	N	ICSPDAT	—
GPA7	5	N	—	—	SCL	IOC	N	ICSPCLK	—
GPB0	9	N	—	—	SDA	IOC	N	—	—
GPB1	23	Y	AN4	—	—	IOC	Y	—	Error Signal In/Out <sup>(3)</sup>
GPB2	24	Y	AN5	—	—	IOC	Y	—	—
V <sub>IN</sub>	11	N	—	—	—	—	—	V <sub>IN</sub>	Device Input Voltage
V <sub>DR</sub>	14	N	—	—	—	—	—	V <sub>DR</sub>	Gate Drive Supply Input Voltage
V <sub>DD</sub>	18	N	—	—	—	—	—	V <sub>DD</sub>	Internal Regulator Output
GND	10	N	—	—	—	—	—	GND	Small Signal Ground
P <sub>GND</sub>	12	N	—	—	—	—	—	—	Large Signal Ground
LDRV	13	N	—	—	—	—	—	—	Low-Side MOSFET Connection
HDRV	16	N	—	—	—	—	—	—	High-Side MOSFET Connection
PHASE	15	N	—	—	—	—	—	—	Switch Node
BOOT	17	N	—	—	—	—	—	—	Floating Bootstrap Supply
+V <sub>SEN</sub>	21	N	—	—	—	—	—	—	Output Voltage Differential Sense
-V <sub>SEN</sub>	22	N	—	—	—	—	—	—	Output Voltage Differential Sense
+I <sub>SEN</sub>	20	N	—	—	—	—	—	—	Current Sense Input
-I <sub>SEN</sub>	19	N	—	—	—	—	—	—	Current Sense Input

- Note**
- 1: The Analog Debug Output is selected when the ATSTCON<BNCHEN> bit is set.
  - 2: Selected when device is functioning as multiple output master or slave by proper configuration of the MLTPH<2:0> bits in the BUFFCON register.
  - 3: Selected when device is functioning as multi-phase master or slave by proper configuration of the MLTPH<2:0> bits in the BUFFCON register.
  - 4: The IOC is disabled when  $\overline{\text{MCLR}}$  is enabled.
  - 5: Weak pull-up always enabled when  $\overline{\text{MCLR}}$  is enabled, otherwise the pull-up is under user control.

# MCP19110/11

## Pin Diagram – 28-Pin QFN (MCP19111)

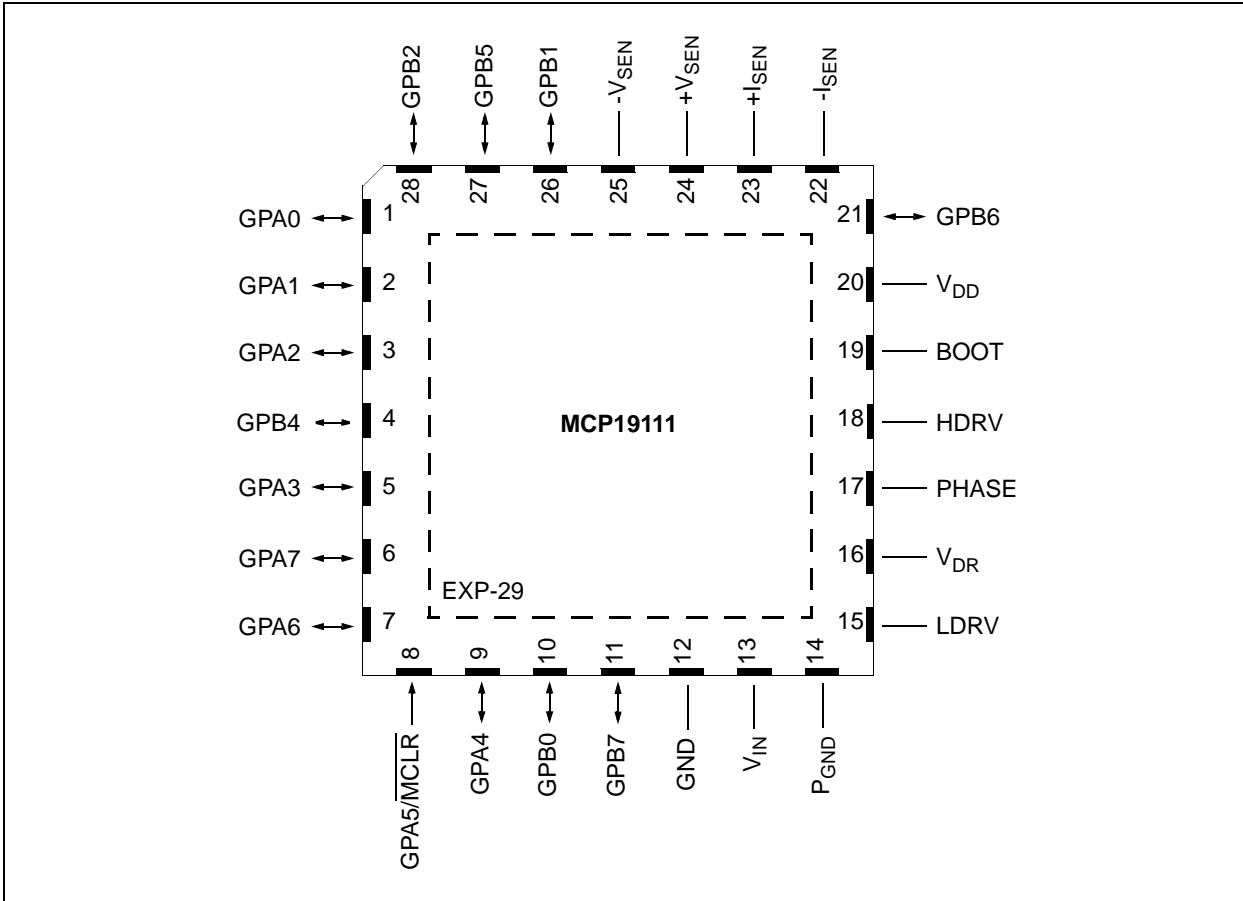

**TABLE 0-1: 28-PIN SUMMARY**

I/O	28-Pin QFN	ANSEL	A/D	Timers	MSSP	Interrupt	Pull-up	Basic	Additional
GPA0	1	Y	AN0	—	—	IOC	Y	—	Analog Debug Output <sup>(1)</sup>
GPA1	2	Y	AN1	—	—	IOC	Y	—	Sync. Signal In/Out <sup>(2, 3)</sup>
GPA2	3	Y	AN2	TOCKI	—	IOC INT	Y	—	—
GPA3	5	Y	AN3	—	—	IOC	Y	—	—
GPA4	9	N	—	—	—	IOC	N	—	—
GPA5	8	N	—	—	—	IOC <sup>(4)</sup>	Y <sup>(5)</sup>	$\overline{\text{MCLR}}$	—
GPA6	7	N	—	—	—	IOC	N	—	—
GPA7	6	N	—	—	SCL	IOC	N	—	—
GPB0	10	N	—	—	SDA	IOC	N	—	—
GPB1	26	Y	AN4	—	—	IOC	Y	—	Error Signal In/Out <sup>(3)</sup>
GPB2	28	Y	AN5	—	—	IOC	Y	—	—
GPB4	4	Y	AN6	—	—	IOC	Y	ICSPDAT ICDDAT	—
GPB5	27	Y	AN7	—	—	IOC	Y	ICSPCLK ICDCLK	Alternate Sync Signal In/Out <sup>(2, 3)</sup>
GPB6	21	N	—	—	—	IOC	Y	—	—
GPB7	11	N	—	—	—	IOC	Y	—	—
V <sub>IN</sub>	13	N	—	—	—	—	—	V <sub>IN</sub>	Device Input Voltage
V <sub>DR</sub>	16	N	—	—	—	—	—	V <sub>DR</sub>	Gate Drive Supply Input Voltage
V <sub>DD</sub>	20	N	—	—	—	—	—	V <sub>DD</sub>	Internal Regulator Output
GND	12	N	—	—	—	—	—	GND	Small Signal Ground
P <sub>GND</sub>	14	N	—	—	—	—	—	—	Large Signal Ground
LDRV	15	N	—	—	—	—	—	—	Low-Side MOSFET Connection
HDRV	18	N	—	—	—	—	—	—	High-Side MOSFET Connection
PHASE	17	N	—	—	—	—	—	—	Switch Node
BOOT	19	N	—	—	—	—	—	—	Floating Bootstrap Supply
+V <sub>SEN</sub>	24	N	—	—	—	—	—	—	Output Voltage Differential Sense
-V <sub>SEN</sub>	25	N	—	—	—	—	—	—	Output Voltage Differential Sense
+I <sub>SEN</sub>	23	N	—	—	—	—	—	—	Current Sense Input
-I <sub>SEN</sub>	22	N	—	—	—	—	—	—	Current Sense Input

- Note** 1: The Analog Debug Output is selected when the ATSTCON<BNCHEN> bit is set.
- 2: Selected when device is functioning as multiple output master or slave by proper configuration of the MLTPH<2:0> bits in the BUFFCON register.
- 3: Selected when device is functioning as multi-phase master or slave by proper configuration of the MLTPH<2:0> bits in the BUFFCON register.
- 4: The IOC is disabled when  $\overline{\text{MCLR}}$  is enabled.
- 5: Weak pull-up always enabled when  $\overline{\text{MCLR}}$  is enabled, otherwise the pull-up is under user control.

# MCP19110/11

---

## Table of Contents

1.0	Device Overview .....	9
2.0	Pin Description .....	12
3.0	Functional Description .....	17
4.0	Electrical Characteristics .....	23
5.0	Digital Electrical Characteristics .....	29
6.0	Configuring the MCP19110/11 .....	37
7.0	Typical Performance Curves .....	53
8.0	System Bench Testing .....	57
9.0	Device Calibration .....	59
10.0	Relative Efficiency Measurement .....	67
11.0	Memory Organization .....	69
12.0	Device Configuration .....	81
13.0	Oscillator Modes .....	83
14.0	Resets .....	85
15.0	Interrupts .....	93
16.0	Power-Down Mode (Sleep) .....	101
17.0	Watchdog Timer (WDT) .....	103
18.0	Flash Program Memory Control .....	105
19.0	I/O Ports .....	111
20.0	Interrupt-On-Change .....	121
21.0	Internal Temperature Indicator Module .....	123
22.0	Analog-to-Digital Converter (ADC) Module .....	125
23.0	Timer0 Module .....	135
24.0	Timer1 Module with Gate Control .....	137
25.0	Timer2 Module .....	140
26.0	PWM Module .....	143
27.0	Master Synchronous Serial Port (MSSP) Module .....	147
28.0	In-Circuit Serial Programming™ (ICSP™) .....	191
29.0	Instruction Set Summary .....	193
30.0	Development Support .....	203
31.0	Packaging Information .....	207
	Appendix A: Revision History .....	213
	Index .....	215
	The Microchip Web Site .....	221
	Customer Change Notification Service .....	221
	Customer Support .....	221
	.....	222
	Product Identification System .....	223

## TO OUR VALUED CUSTOMERS

It is our intention to provide our valued customers with the best documentation possible to ensure successful use of your Microchip products. To this end, we will continue to improve our publications to better suit your needs. Our publications will be refined and enhanced as new volumes and updates are introduced.

### Most Current Data Sheet

To obtain the most up-to-date version of this data sheet, please register at our World Wide Web site at:

<http://www.microchip.com>

You can determine the version of a data sheet by examining its literature number found on the bottom outside corner of any page. The last character of the literature number is the version number, (e.g., DS30000000A is version A of document DS30000000).

### Errata

An errata sheet, describing minor operational differences from the data sheet and recommended workarounds, may exist for current devices. As device/documentation issues become known to us, we will publish an errata sheet. The errata will specify the revision of silicon and revision of document to which it applies.

To determine if an errata sheet exists for a particular device, please check with one of the following:

- Microchip's World Wide Web site; <http://www.microchip.com>
- Your local Microchip sales office (see last page)

When contacting a sales office, please specify which device, revision of silicon and data sheet (include literature number) you are using.

### Customer Notification System

Register on our web site at [www.microchip.com](http://www.microchip.com) to receive the most current information on all of our products.

# MCP19110/11

---

NOTES:



## 1.0 DEVICE OVERVIEW

The MCP19110/11 is a highly integrated, mixed signal, analog pulse-width modulation (PWM) current mode controller with an integrated microcontroller core for synchronous DC/DC step-down applications. Since the MCP19110/11 uses traditional analog control circuitry to regulate the output of the DC/DC converter, the integration of the PIC<sup>®</sup> microcontroller mid-range core is used to provide complete customization of device operating parameters, start-up and shut down profiles, protection levels and fault handling procedures.

The MCP19110/11 is designed to efficiently operate from a single 4.5V to 32V supply. It features integrated synchronous drivers, bootstrap device, internal linear regulator and 4 kW nonvolatile memory all in a space-saving 24-pin 4 mm x 4mm QFN package (MCP19110) or 28-pin 5 mm x 5 mm QFN package (MCP19111).

After initial device configuration using Microchip's MPLAB<sup>®</sup> X Integrated Development Environment (IDE) software, the PMBus or I<sup>2</sup>C can be used by a host to communicate with, or modify, the operation of the MCP19110/11.

Two internal linear regulators generate two 5V rails. One 5V rail is used to provide power for the internal analog circuitry and is contained on-chip. The second 5V rail provides power to the PIC device and is present on the V<sub>DD</sub> pin. It is recommended that a 1 μF capacitor be placed between V<sub>DD</sub> and P<sub>GND</sub>. The V<sub>DD</sub> pin may also be directly connected to the V<sub>DR</sub> pin, or connected through a low-pass RC filter. The V<sub>DR</sub> pin provides power to the internal synchronous driver.

**FIGURE 1-1: TYPICAL APPLICATION CIRCUIT**

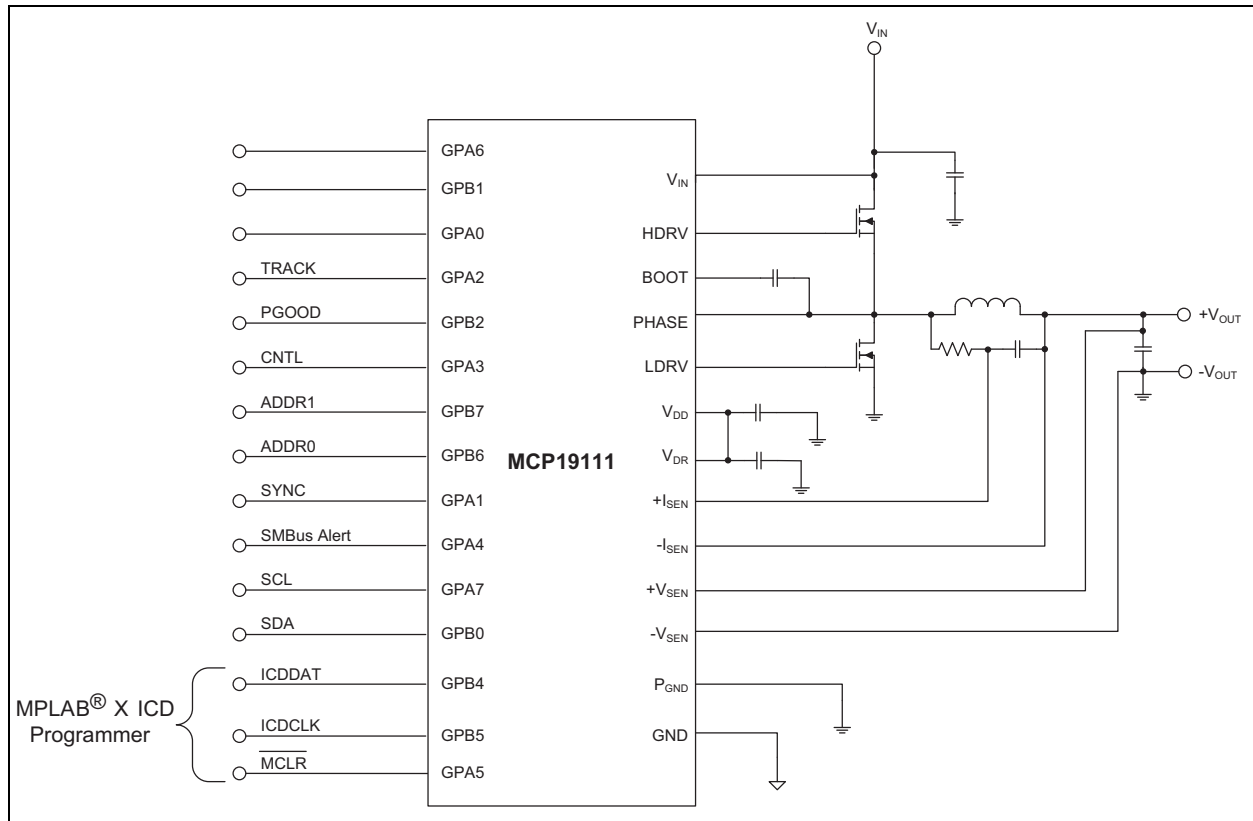
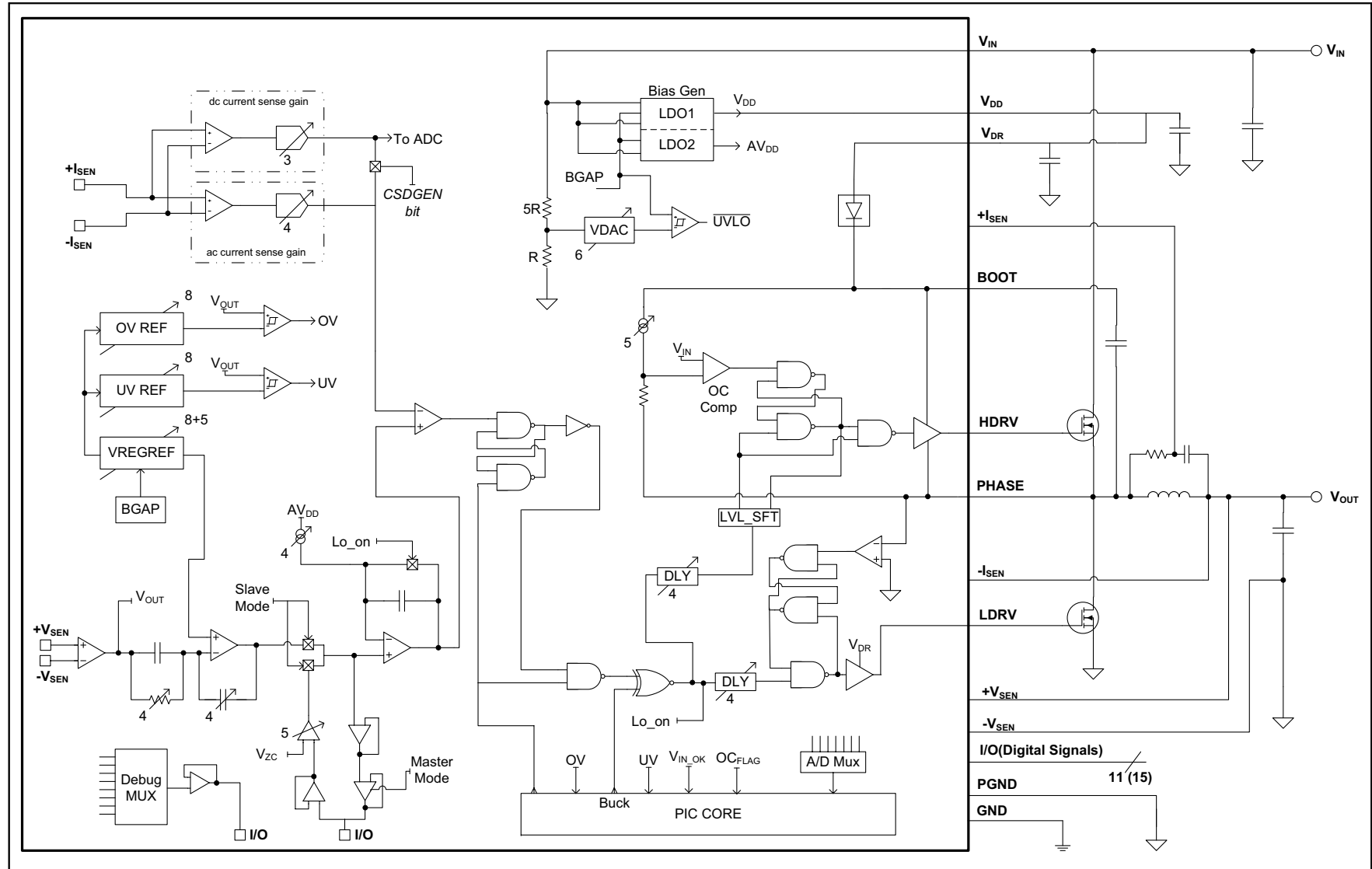
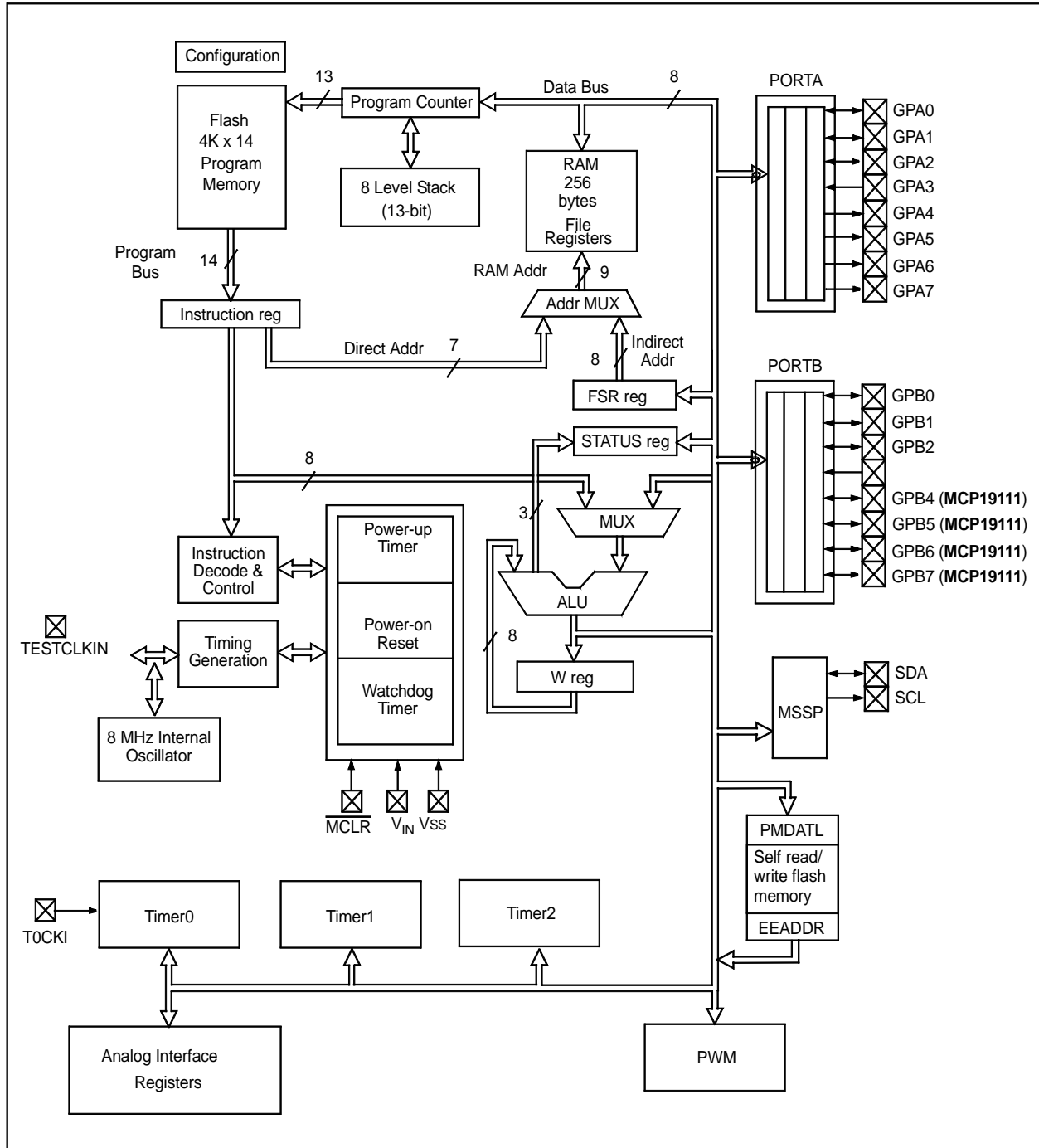

FIGURE 1-2: MCP19110/11 SYNCHRONOUS BUCK BLOCK DIAGRAM



**FIGURE 1-3: MICROCONTROLLER CORE BLOCK DIAGRAM**



# MCP19110/11

## 2.0 PIN DESCRIPTION

The MCP19110/11 family of devices feature pins that have multiple functions associated with each pin. Table 2-1 provides a description of the different functions. See Section 2.1 “Detailed Pin Functional Description” for more detailed information.

**TABLE 2-1: MCP19110/11 PINOUT DESCRIPTION**

Name	Function	Input Type	Output Type	Description
GPA0/AN0/ANALOG_TEST	GPA0	TTL	CMOS	General purpose I/O
	AN0	AN	—	A/D Channel 0 input.
	ANALOG_TEST	—	—	Internal analog signal multiplexer output <sup>(1)</sup>
GPA1/AN1/CLKPIN	GPA1	TTL	CMOS	General purpose I/O
	AN1	AN	—	A/D Channel 1 input.
	CLKPIN	—	—	Switching frequency clock input or output <sup>(2,3)</sup>
GPA2/AN2/T0CKI/INT	GPA2	TTL	CMOS	General purpose I/O
	AN2	AN	—	A/D Channel 2 input
	T0CKI	ST	—	Timer0 clock input
	INT	ST	—	External interrupt
GPA3/AN3	GPA3	TTL	CMOS	General purpose I/O
	AN3	AN	—	A/D Channel 3 input
GPA4	GPA4	TTL	OD	General purpose I/O
GPA5/ $\overline{\text{MCLR}}$	GPA5	TTL	—	General purpose input only
	$\overline{\text{MCLR}}$	ST	—	Master Clear with internal pull-up
GPA6/ICSPDAT	GPA6	ST	CMOS	General purpose I/O
	ICSPDAT		CMOS	Serial Programming Data I/O ( <b>MCP19110 Only</b> )
GPA7/SCL/ICSPCLK	GPA7	ST	OD	General purpose open-drain I/O
	SCL	I <sup>2</sup> C	OD	I <sup>2</sup> C clock
	ICSPCLK	ST	—	Serial Programming Clock ( <b>MCP19110 Only</b> )
GPB0/SDA	GPB0	TTL	OD	General purpose I/O
	SDA	I <sup>2</sup> C	OD	I <sup>2</sup> C data input/output
GPB1/AN4/EAPIN	GPB1	TTL	CMOS	General purpose I/O
	AN4	AN	—	A/D Channel 4 input
	EAPIN	—	—	Error amplifier signal input/output <sup>(3)</sup>
GPB2/AN5	GPB2	TTL	CMOS	General purpose I/O
	AN5	AN	—	A/D Channel 5 input
GPB4/AN6/ICSPDAT ( <b>MCP19111 Only</b> )	GPB4	TTL	CMOS	General purpose I/O
	AN6	AN	—	A/D Channel 6 input
	ICSPDAT	ST	CMOS	Serial Programming Data I/O

**Legend:** AN = Analog input or output    CMOS = CMOS compatible input or output    OD = Open Drain  
TTL = TTL compatible input    ST = Schmitt Trigger input with CMOS levels    I<sup>2</sup>C = Schmitt Trigger input with I<sup>2</sup>C

**Note 1:** Analog Test is selected when the ATSTCON<BNCHEN> bit is set.

**Note 2:** Selected when device is functioning as multiple output master or slave by proper configuration of the MLTPH<2:0> bits in the BUFFCON register.

**Note 3:** Selected when device is functioning as multi-phase master or slave by proper configuration of the MLTPH<2:0> bits in the BUFFCON register.

**TABLE 2-1: MCP19110/11 PINOUT DESCRIPTION (CONTINUED)**

Name	Function	Input Type	Output Type	Description
GPB5/AN7/ICSPCLK/ ALT_CLKPIN (MCP19111 Only)	GPB5	TTL	CMOS	General purpose I/O
	AN7	AN	—	A/D Channel 7 input
	ICSPCLK	ST	—	Serial Programming Clock
	ALT_CLKPIN	—	—	Alternate switching frequency clock input or output <sup>(2,3)</sup>
GPB6 (MCP19111 Only)	GPB6	TTL	CMOS	General purpose I/O
GPB7 (MCP19111 Only)	GPB7	TTL	CMOS	General purpose I/O
V <sub>IN</sub>	V <sub>IN</sub>	—	—	Device input supply voltage
V <sub>DD</sub>	V <sub>DD</sub>	—	—	Internal +5V LDO output pin
V <sub>DR</sub>	V <sub>DR</sub>	—	—	Gate drive supply input voltage pin
GND	GND	—	—	Small signal quiet ground
P <sub>GND</sub>	P <sub>GND</sub>	—	—	Large signal power ground
LDRV	LDRV	—	—	High-current drive signal connected to the gate of the low-side MOSFET
HDRV	HDRV	—	—	Floating high-current drive signal connected to the gate of the high-side MOSFET
PHASE	PHASE	—	—	Synchronous buck switch node connection
BOOT	BOOT	—	—	Floating bootstrap supply
+V <sub>SEN</sub>	+V <sub>SEN</sub>	—	—	Positive input of the output voltage sense differential amplifier
-V <sub>SEN</sub>	-V <sub>SEN</sub>	—	—	Negative input of the output voltage sense differential amplifier
+I <sub>SEN</sub>	+I <sub>SEN</sub>	—	—	Current sense input
-I <sub>SEN</sub>	-I <sub>SEN</sub>	—	—	Current sense input
EP	—	—	—	Exposed Thermal Pad

**Legend:** AN = Analog input or output    CMOS = CMOS compatible input or output    OD = Open Drain  
TTL = TTL compatible input    ST = Schmitt Trigger input with CMOS levels    I<sup>2</sup>C = Schmitt Trigger input with I<sup>2</sup>C

- Note** 1: Analog Test is selected when the ATSTCON<BNCHEN> bit is set.  
2: Selected when device is functioning as multiple output master or slave by proper configuration of the MLTPH<2:0> bits in the BUFFCON register.  
3: Selected when device is functioning as multi-phase master or slave by proper configuration of the MLTPH<2:0> bits in the BUFFCON register.

# MCP19110/11

---

## 2.1 Detailed Pin Functional Description

### 2.1.1 GPA0 PIN

GPA0 is a general purpose TTL input or CMOS output pin whose data direction is controlled in TRISGPA. An internal weak pull-up and interrupt-on-change are also available.

AN0 is an input to the A/D. To configure this pin to be read by the A/D on channel 0, bits TRISA0 and ANSA0 must be set.

When the ATSTCON<BNCHEN> bit is set, this pin is configured as the ANALOG\_TEST function. It is a buffered output of the internal analog signal multiplexer. Signals present on this pin are controlled by the BUFFCON register, see [Register 8-2](#).

### 2.1.2 GPA1 PIN

GPA1 is a general purpose TTL input or CMOS output pin whose data direction is controlled in TRISGPA. An internal weak pull-up and interrupt-on-change are also available.

AN1 is an input to the A/D. To configure this pin to be read by the A/D on channel 1, bits TRISA1 and ANSA1 must be set.

When the MCP19110/11 is configured as a multiple output or multi-phase MASTER or SLAVE, this pin is configured to be the switching frequency synchronization input or output, CLKPIN. See [Section 3.10.6 “Multi-Phase System”](#) and [Section 3.10.7 “Multiple Output System”](#) for more information.

### 2.1.3 GPA2 PIN

GPA2 is a general purpose TTL input or CMOS output pin whose data direction is controlled in TRISGPA. An internal weak pull-up and interrupt-on-change are also available.

AN2 is an input to the A/D. To configure this pin to be read by the A/D on channel 2, bits TRISA2 and ANSA2 must be set.

When bit T0CS is set, the T0CKI function is enabled. See [Section 23.0 “Timer0 Module”](#) for more information.

GPA2 can also be configured as an external interrupt by setting of the INTE bit. See [Section 15.2 “GPA2/INT Interrupt”](#) for more information.

### 2.1.4 GPA3 PIN

GPA3 is a general purpose TTL input or CMOS output pin whose data direction is controlled in TRISGPA. An internal weak pull-up and interrupt-on-change are also available.

AN3 is an input to the A/D. To configure this pin to be read by the A/D on channel 3, bits TRISA3 and ANSA3 must be set.

### 2.1.5 GPA4 PIN

GPA4 is a true open-drain general purpose pin whose data direction is controlled in TRISGPA. There is no internal connection between this pin and device  $V_{DD}$ , making this pin ideal to be used as an SMBus Alert pin. This pin does not have a weak pull-up, but interrupt-on-change is available.

### 2.1.6 GPA5 PIN

GPA5 is a general purpose TTL input-only pin. An internal weak pull-up and interrupt-on-change are also available.

For programming purposes, this pin is to be connected to the MCLR pin of the serial programmer. See [Section 28.0 “In-Circuit Serial Programming™ \(ICSP™\)”](#) for more information.

### 2.1.7 GPA6 PIN

GPA6 is a general purpose CMOS input/output pin whose data direction is controlled in TRISGPA. An interrupt-on-change is also available.

On the MCP19110, the ISCPDAT is the serial programming data input function. This is used in conjunction with ICSPCLK to serial program the device. This pin function is only implemented on the MCP19110.

### 2.1.8 GPA7 PIN

GPA7 is a true open-drain general purpose pin whose data direction is controlled in TRISGPA. There is no internal connection between this pin and device  $V_{DD}$ . This pin does not have a weak pull-up, but interrupt-on-change is available.

When the MCP19110/11 is configured for I<sup>2</sup>C communication (see [Section 27.2 “I<sup>2</sup>C Mode Overview”](#)), GPA7 functions as the I<sup>2</sup>C clock, SCL.

On the MCP19110, the ISCPCLK is the serial programming clock function. This is used in conjunction with ICSPDAT to serial program the device. This pin function is only implemented on the MCP19110.

### 2.1.9 GPB0 PIN

GPB0 is a true open-drain general purpose pin whose data direction is controlled in TRISGPB. There is no internal connection between this pin and device  $V_{DD}$ . This pin does not have a weak pull-up, but interrupt-on-change is available.

When the MCP19110/11 is configured for I<sup>2</sup>C communication (see [Section 27.2 “I<sup>2</sup>C Mode Overview”](#)), GPB0 functions as the I<sup>2</sup>C clock, SDA.

## 2.1.10 GPB1 PIN

GPB1 is a general purpose TTL input or CMOS output pin whose data direction is controlled in TRISGPB. An internal weak pull-up and interrupt-on-change are also available.

AN4 is an input to the A/D. To configure this pin to be read by the A/D on channel 4, bits TRISB1 and ANSB1 must be set.

When the MCP19110/11 is configured as a multiple output or multi-phase MASTER or SLAVE, this pin is configured to be the error amplifier signal input or output. See [Section 3.10.6 “Multi-Phase System”](#) and [Section 3.10.7 “Multiple Output System”](#), for more information.

## 2.1.11 GPB2 PIN

GPB2 is a general purpose TTL input or CMOS output pin whose data direction is controlled in TRISGPB. An internal weak pull-up and interrupt-on-change are also available.

AN5 is an input to the A/D. To configure this pin to be read by the A/D on channel 5, bits TRISB2 and ANSB2 must be set.

## 2.1.12 GPB4 PIN

This pin and its associated functions are only available on the MCP19111 device.

GPB4 is a general purpose TTL input or CMOS output pin whose data direction is controlled in TRISGPB. An internal weak pull-up and interrupt-on-change are also available.

AN6 is an input to the A/D. To configure this pin to be read by the A/D on channel 6, bits TRISB4 and ANSB4 must be set.

On the MCP19111, the ISCPDAT is the serial programming data input function. This is used in conjunction with ICSPCLK to serial program the device. This pin function is only implemented on the MCP19111.

## 2.1.13 GBP5 PIN

This pin and its associated functions are only available on the MCP19111 device.

GPB5 is a general purpose TTL input or CMOS output pin whose data direction is controlled in TRISGPB. An internal weak pull-up and interrupt-on-change are also available.

AN7 is an input to the A/D. To configure this pin to be read by the A/D on channel 7, bits TRISB5 and ANSB5 must be set.

On the MCP19111, the ISCPCLK is the serial programming clock function. This is used in conjunction with ICSPDAT to serial program the device. This pin function is only implemented on the MCP19111.

This pin can also be configured as an alternate switching frequency synchronization input or output, ALT\_-CLKPIN, for use in multiple output or multi-phase systems. See [Section 19.1 “Alternate Pin Function”](#) for more information.

## 2.1.14 GPB6 PIN

This pin and associated functions is only available on the MCP19111 device.

GPB6 is a general purpose TTL input or CMOS output pin whose data direction is controlled in TRISGPB. An internal weak pull-up and interrupt-on-change are also available.

## 2.1.15 GPB7 PIN

This pin and associated functions is only available on the MCP19111 device.

GPB7 is a general purpose TTL input or CMOS output pin whose data direction is controlled in TRISGPB. An internal weak pull-up and interrupt-on-change are also available.

## 2.1.16 $V_{IN}$ PIN

Device input power connection pin. It is recommended that capacitance be placed between this pin and the GND pin of the device.

## 2.1.17 $V_{DD}$ PIN

The output of the internal +5.0V regulator is connected to this pin. It is recommended that a 1.0  $\mu$ F bypass capacitor be connected between this pin and the GND pin of the device. The bypass capacitor should be placed physically close to the device.

## 2.1.18 $V_{DR}$ PIN

The 5V supply for the low-side driver is connected to this pin. The pin can be connected by an RC filter to the  $V_{DD}$  pin.

## 2.1.19 GND PIN

GND is the small signal ground connection pin. This pin should be connected to the exposed pad, on the bottom of the package.

## 2.1.20 $P_{GND}$ PIN

Connect all large signal level ground returns to  $P_{GND}$ . These large-signal level ground traces should have a small loop area and minimal length to prevent coupling of switching noise to sensitive traces.

## 2.1.21 LDRV PIN

The gate of the low-side or rectifying MOSFET is connected to LDRV. The PCB tracing connecting LDRV to the gate must be of minimal length and appropriate width to handle the high peak drive currents and fast voltage transitions.

# MCP19110/11

---

## 2.1.22 HDRV PIN

The gate of the high-side MOSFET is connected to HDRV. This is a floating driver referenced to PHASE. The PCB trace connecting HDRV to the gate must be of minimal length and appropriate width to handle the high-peak drive current and fast voltage transitions.

## 2.1.23 PHASE PIN

The PHASE pin provides the return path for the high-side gate driver. The source of the high-side MOSFET, drain of the low-side MOSFET and the inductor are connected to this pin.

## 2.1.24 BOOT PIN

The BOOT pin is the floating bootstrap supply pin for the high-side gate driver. A capacitor is connected between this pin and the PHASE pin to provide the necessary charge to turn on the high-side MOSFET.

## 2.1.25 $+V_{SEN}$ PIN

The non-inverting input of the unity gain amplifier used for output voltage remote sensing is connected to the  $+V_{SEN}$  pin. This pin can be internally pulled-up to  $V_{DD}$  by setting PE1<PUEN> bit.

## 2.1.26 $-V_{SEN}$ PIN

The inverting input of the unity gain amplifier used for output voltage remote sensing is connected to the  $-V_{SEN}$  pin. This pin can be internally pull-down to GND by setting PE1<PDEN> bit.

## 2.1.27 $+I_{SEN}$ PIN

The non-inverting input of the current sense amplifier is connected to the  $+I_{SEN}$  pin.

## 2.1.28 $-I_{SEN}$ PIN

The inverting input of the current sense amplifier is connected to the  $-I_{SEN}$  pin.

## 2.1.29 EXPOSED PAD (EP)

There is no internal connection to the Exposed Thermal Pad. The EP should be connected to the GND pin and to the GND PCB plane to aid in the removal of the heat.



## 3.0 FUNCTIONAL DESCRIPTION

### 3.1 Linear Regulators

Two internal linear regulators generate two 5V rails. One 5V rail is used to provide power for the internal analog circuitry and is contained on-chip. The second 5V rail provides power to the internal PIC core and it is present on the  $V_{DD}$  pin. It is recommended that a 1  $\mu$ F capacitor be placed between  $V_{DD}$  and  $P_{GND}$ .

The  $V_{DR}$  pin provides power to the internal synchronous MOSFET driver.  $V_{DD}$  can be directly connected to  $V_{DR}$  or connected through a low-pass RC filter to provide noise filtering. A 1  $\mu$ F ceramic bypass capacitor should be placed between  $V_{DR}$  and  $P_{GND}$ . When connecting  $V_{DD}$  to  $V_{DR}$ , the gate drive current required to drive the external MOSFETs must be added to the MCP19110/11 quiescent current,  $I_{Q(max)}$ . This total current must be less than the maximum current,  $I_{DD-OUT}$ , available from  $V_{DD}$  that is specified in [Section 4.2 “Electrical Characteristics”](#).

#### EQUATION 3-1: TOTAL REGULATOR CURRENT

$$I_{DD-OUT} > (I_Q + I_{DRIVE} + I_{EXT})$$

Where:

- $I_{DD-OUT}$  is the total current available from  $V_{DD}$
- $I_Q$  is the device quiescent current
- $I_{DRIVE}$  is the current required to drive the external MOSFETs
- $I_{EXT}$  is the amount of current used to power additional external circuitry.

#### EQUATION 3-2: GATE DRIVE CURRENT

$$I_{DRIVE} = (Q_{gHIGH} + Q_{gLOW}) \times F_{SW}$$

Where:

- $I_{DRIVE}$  is the current required to drive the external MOSFETs
- $Q_{gHIGH}$  is the total gate charge of the high-side MOSFET
- $Q_{gLOW}$  is the total gate charge of the low-side MOSFET
- $F_{SW}$  is the switching frequency

Alternatively, an external regulator can be used to power the synchronous driver. An external 5V source can be connected to  $V_{DR}$ . The amount of current required from this external source can be found in [Equation 3-2](#). Care must be taken that the voltage applied to  $V_{DR}$  does not exceed the maximum ratings found in [Section 4.1 “Absolute Maximum Ratings \(†\)”](#).

### 3.2 Internal Synchronous Driver

The internal synchronous driver is capable of driving two N-Channel MOSFETs in a synchronous rectified buck converter topology. The gate of the floating MOSFET is connected to the HDRV pin. The source of this MOSFET is connected to the PHASE pin. The HDRV pin source and sink current is configurable. By setting the DRVSTR bit in the PE1 register, the high-side is capable of sourcing and sinking a peak current of 1A. By clearing this bit, the source and sink peak current is 2A.

**Note 1:** The PE1<DRVSTR> bit configures the peak source/sink current of the HDRV pin.

The MOSFET connected to the LDRV pin is not floating. The low-side MOSFET gate is connected to the LDRV pin and the source of this MOSFET is connected to  $P_{GND}$ . The drive strength of the LDRV pin is not configurable. This pin is capable of sourcing a peak current of 2A. The peak sink current is 4A. This helps keep the low-side MOSFET off when the high-side MOSFET is turning on.

**Note 1:** Refer to [Figure 1-1](#) for a graphical representation of the MOSFET connections.

#### 3.2.1 MOSFET DRIVER DEAD TIME

The MOSFET driver dead time is defined as the time between one drive signal going low and the complimentary drive signal going high. Refer to [Figure 6-2](#). The MCP19110/11 has the capability to adjust both the high-side and low-side driver dead time independently. The adjustment of the driver dead time is controlled by the DEADCON register and is adjustable in 4 ns increments.

**Note 1:** The DEADCON register controls the amount of dead time added to the HDRV or LDRV signal. The dead time circuitry is enabled by the LDLYBY and HDLYBY bits in the PE1 register.

#### 3.2.2 MOSFET DRIVER CONTROL

The MCP19110/11 has the ability to disable the entire synchronous driver or just one side of the synchronous drive signal. The bits that control the MOSFET driver can be found in the [Register 8-1](#).

By setting ATSTCON<DRVDIS>, the entire synchronous driver is disabled. The HDRV and LDRV signals are set low and the PHASE pin is floating. Clearing this bit allows normal operation.

Individual control of the HDRV or LDRV signal is accomplished by setting or clearing the HIDIS or LODIS bits in the ATSTCON register. When either driver is disabled, the output signal is set low.

# MCP19110/11

## 3.3 Output Voltage

The output voltage is configured by the settings contained in the OVCCON and OVFCN registers. No external resistor divider is needed to set the output voltage. Refer to [Section 6.10 “Output Voltage Configuration”](#).

The MCP19110/11 contains a unity gain differential amplifier used for remote sensing of the output voltage. Connect the  $+V_{SEN}$  and  $-V_{SEN}$  pins directly at the load for better load regulation. The  $+V_{SEN}$  and  $-V_{SEN}$  are the positive and negative inputs, respectively, of the differential amplifier.

## 3.4 Switching Frequency

The switching frequency is configurable over the range of 100 kHz to 1.6 MHz. The Timer2 module is used to generate the HDRV/LDRV switching frequency. Refer to [Section 26.0 “PWM Module”](#) for more information. [Example 3-1](#) shows how to configure the MCP19110/11 for a switching frequency of 300 kHz.

### EXAMPLE 3-1: CONFIGURING F<sub>sw</sub>

```

BANKSEL    T2CON
CLRF      T2CON    ;Turn off Timer2
CLRF      TMR2     ;Initialize module
MOVLW    0x19     ;Fsw=300 kHz
MOVWF    PR2
MOVLW    0x0A     ;Max duty cycle=40%
MOVWF    PWMRL
MOVLW    0x00     ;No phase shift
MOVWF    PWMPHL
MOVLW    0x04     ;Turn on Timer2
MOVWF    T2CON
    
```

## 3.5 Compensation

The MCP19110/11 is an analog peak current mode controller with integrated adjustable compensation. The CMPZCON register is used to adjust the compensation zero frequency and gain. [Figure 3-1](#) shows the internal compensation network with the output differential amplifier.

**FIGURE 3-1: SIMPLIFIED INTERNAL COMPENSATION**

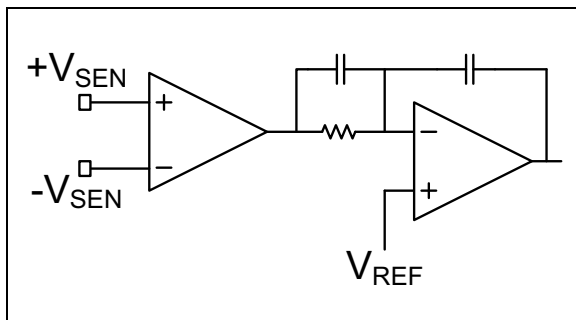

## 3.6 Slope Compensation

In current mode control systems, slope compensation needs to be added to the control path to help prevent subharmonic oscillation when operating with greater than 50% duty cycle. In the MCP19110/11, a negative slope is added to the error amplifier output signal before it is compared to the current sense signal. The amount of slope added is controlled by the SLPCRCON register, [Register 6-7](#).

**Note 1:** To enable the slope compensation circuitry, the ABECON<SLCPBY> bit must be cleared.

The amount of slope compensation added should be equal to the inductor current down slope during the high-side off time.

## 3.7 Current Sense

The output current is differentially sensed by the MCP19110/11. The sense element can be either a resistor placed in series with the output, or the series resistance of the inductor. If the inductor series resistance is used, a filter is needed to remove the large AC component of the voltage that appears across the inductor and leave only the small AC voltage that appears across the inductor resistance, as shown in [Figure 3-2](#). This small AC voltage is representative of the output current.

**FIGURE 3-2: INDUCTOR CURRENT SENSE FILTER**

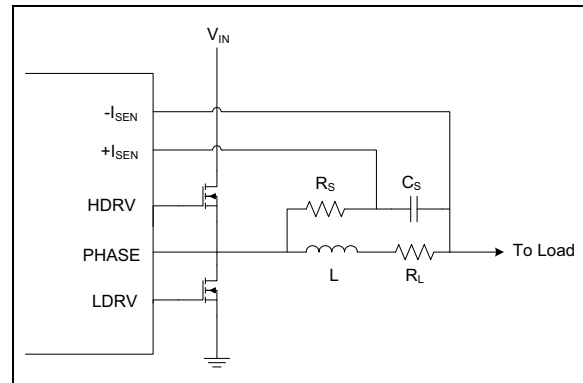

The value of  $R_S$  and  $C_S$  can be found by using [Equation 3-3](#). When the current sense filter time constant is set equal to the inductor time constant, the voltage appearing across  $C_S$  approximates the current flowing in the inductor, multiplied by the inductor resistance.

## EQUATION 3-3: CALCULATING FILTER VALUES

$$\frac{L}{R_L} = (R_S \times C_S)$$

Where:

- L is the inductance value of the output inductor
- $R_L$  is the series resistance of the output inductor
- $R_S$  is the current sense filter resistor
- $C_S$  is the current sense filter capacitor

Both AC gain and DC gain can be added to the current sense signal. Refer to [Section 6.3 “Current Sense AC Gain”](#) and [Section 6.4 “Current Sense DC Gain”](#) for more information.

## 3.7.1 PLACEMENT OF THE CURRENT SENSE FILTER COMPONENTS

The amplitude of the current sense signal is typically less than 100 mV peak-to-peak. Therefore, the small signal current sense traces are very susceptible to circuit noise. When designing the printed circuit board, placement of  $R_S$  and  $C_S$  is very important. The  $+I_{SEN}$  and  $-I_{SEN}$  traces should be routed parallel to each other with minimum spacing. This Kelvin sense routing technique helps minimize noise sensitivity. The filter capacitor ( $C_S$ ), should be placed as close to the MCP19110/11 as possible. This will help filter any noise that is injected onto the current sense lines. The trace connecting  $C_S$  to the inductor should occur directly at the inductor and not at any other  $+V_{SEN}$  trace. The filter resistor ( $R_S$ ), should be placed close to the inductor. See [Figure 3-3](#) for component placement. Care should also be taken to avoid routing the  $+I_{SEN}$  and  $-I_{SEN}$  traces near the high current switching nodes of the HDRV, LDRV, PHASE, or BOOST traces. It is recommended that a ground layer be placed between these high current traces and the small signal current sense traces.

**FIGURE 3-3: CURRENT SENSE FILTER COMPONENT PLACEMENT**

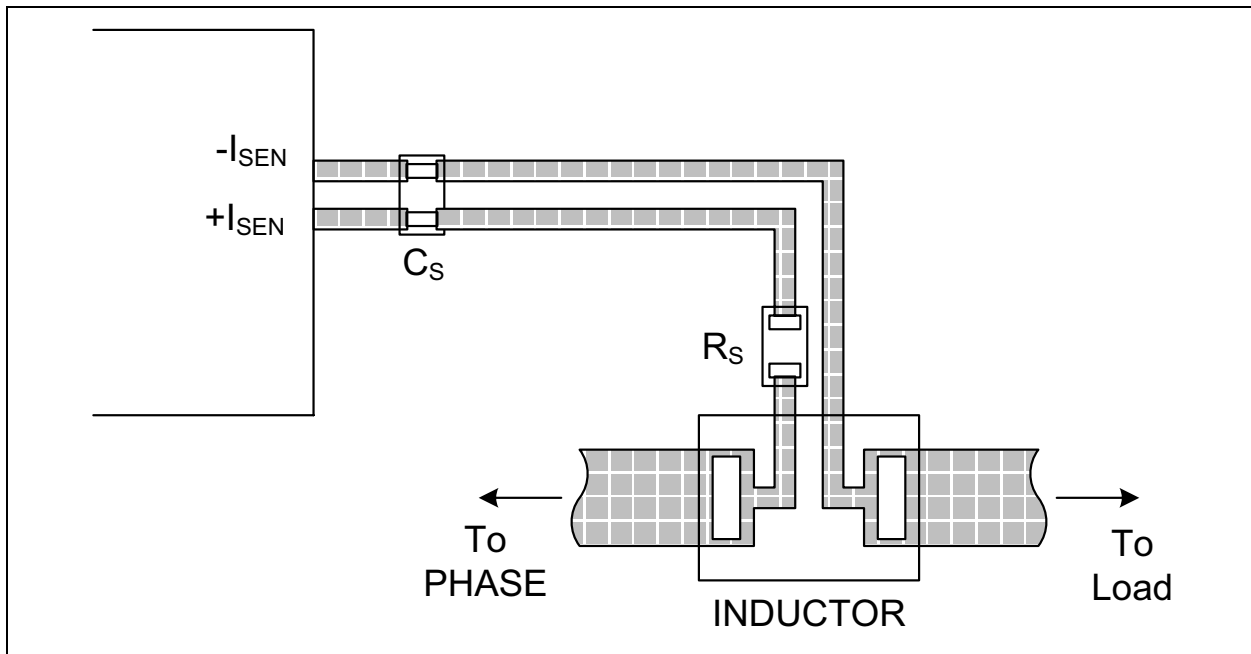

# MCP19110/11

## 3.8 Protection Features

### 3.8.1 INPUT UNDERVOLTAGE LOCKOUT

The input Undervoltage Lockout (UVLO) threshold is configurable by the VINLVL register, [Register 6-1](#). When the voltage at the  $V_{IN}$  pin of the MCP19110/11 is below the configurable threshold, the PIR2<VINIF> flag will be set. This flag is cleared by hardware once the  $V_{IN}$  voltage is greater than the configurable threshold. By enabling the global interrupts or polling the VINIF bit, the MCP19110/11 can be disabled when the  $V_{IN}$  voltage is below the threshold.

**Note 1:** The UVLO DAC must be enabled by setting the VINLVL<UVLOEN> bit.

- 2: Interrupt flag bits are set when an interrupt condition occurs, regardless of the state of its corresponding enable bit or the Global Enable bit (GIE) of the INTCON register.

Some techniques that can be used to disable the switching of the MCP19110/11 while the VINIF flag is set include setting the ATSTCON<DVRDIS> bit, setting the reference voltage to 0V, setting the PE1<PUEN> bit, or setting the ATSTCON<HIDIS> and ATSTCON<LODIS> bits.

### 3.8.2 OUTPUT OVERCURRENT

The MCP19110/11 senses the voltage drop across the high-side MOSFET to determine when an output overcurrent (OC) exists. This voltage drop is configurable by the OCCON register ([Register 6-2](#)), and is measured when the high-side MOSFET is conducting. To avoid false OC events, leading edge blanking is applied to the measurements. The amount of blanking is controlled by the OCLEB<1:0> bits in the OCCON register. See [Section 6.2 “Output Overcurrent”](#) for more information.

When the input voltage is greater than 20V, or if the  $R_{DS(ON)}$  of the high-side MOSFET is such that the programmed overcurrent threshold does not produce acceptable peak overcurrent protection, an alternative method must be used to determine an overcurrent situation. An alternative technique can use the configurable output undervoltage protection, and the PE1<UVTEE> bit, to quickly terminate switching when the output voltage drops because of an overcurrent event.

**Note 1:** The OC DAC must be enabled by setting the OCCON<OCEN> bit.

### 3.8.3 OUTPUT UNDERVOLTAGE

When the output undervoltage DAC is enabled by setting the ABECON<UVDCEN> bit, the voltage measured between the  $+V_{SEN}$  and  $-V_{SEN}$  pins is monitored and compared to the UV threshold controlled by the OUVCON register ([Register 6-12](#)). When the output voltage is below the threshold, the PIR2<UVIF> flag will be set. Once set, firmware can determine how the MCP19110/11 responds to the fault condition and it must clear the UVIF flag.

By setting the PE1<UVTEE> bit, the HDRV and LDRV signals will be asserted low when the UVIF flag is set. The signals will remain low until the flag is cleared.

**Note 1:** The UV DAC must be enabled by setting the ABECON<UVDCEN> bit.

- 2: Interrupt flag bits are set when an interrupt condition occurs, regardless of the state of its corresponding enable bit or the Global Enable bit (GIE) of the INTCON register.
- 3: The output of the remote sense comparator is compared to the UV threshold. Therefore, the offset in this comparator should be considered when calculating the UV threshold.

### 3.8.4 OUTPUT OVERVOLTAGE

When the output overvoltage DAC is enabled by setting the ABECON<OVDCEN> bit, the voltage measured between the  $+V_{SEN}$  and  $-V_{SEN}$  pins is monitored and compared to the OV threshold controlled by the OOVCON register ([Register 6-13](#)). When the output voltage is above the threshold, the PIR2<OVIF> flag will be set. Once set, firmware can determine how the MCP19110/11 responds to the fault condition and it must clear the OVIF flag.

By setting the PE1<OVTEE> bit, the HDRV and LDRV signals will be asserted low when the OVIF flag is set. The signals will remain low until the flag is cleared.

**Note 1:** The OV DAC must be enabled by setting the ABECON<OVDCEN> bit.

- 2: Interrupt flag bits are set when an interrupt condition occurs, regardless of the state of its corresponding enable bit or the Global Enable bit (GIE) of the INTCON register.
- 3: The output of the remote sense comparator is compared to the OV threshold. Therefore, the offset in this comparator should be considered when calculating the OV threshold.

## 3.8.5 OVERTEMPERATURE

The MCP19110/11 features a hardware overtemperature shutdown protection typically set at +160°C. No firmware fault-handling procedure is required to shutdown the MCP19110/11 for an overtemperature condition.

## 3.9 PIC Microcontroller Core

Integrated into the MCP19110/11 is the PIC microcontroller mid-range core. This is a fully functional microcontroller, allowing proprietary features to be implemented. Setting the CONFIG<CP> bit enables the code protection. The firmware is then protected from external reads or writes. Various status and fault bits are available to customize the fault handling response.

A minimal amount of firmware is required to properly configure the MCP19110/11. [Section 6.0 “Configuring the MCP19110/11”](#) contains detailed information about each register that needs to be set for the MCP19110/11 device to operate. To aid in the development of the required firmware, a Graphical User Interface (GUI) has been developed. This GUI can be used to quickly configure the MCP19110/11 for basic operation. Customized or proprietary features can then be added to the GUI generated firmware.

**Note 1:** The GUI can be found on the MCP19110/11 product page on [www.microchip.com](http://www.microchip.com).

**2:** Microchip's MPLAB X Integrated Development Environment Software is required to use the GUI.

The MCP19110/11 device features firmware debug support. See [Section 30.0 “Development Support”](#) for more information.

## 3.10 Miscellaneous Features

### 3.10.1 DEVICE ADDRESSING

The communication address of the MCP19110/11 is stored in the SSPADD register. This value can be loaded when the device firmware is programmed or configured by external components. By reading a voltage on a GPIO with the ADC, a device specific address can be stored into the SSPADD register.

The MCP19110/11 contains a second address register, SSPADD2. This is a 7-bit address that can be used as the SMBus alert address when PMBus communication is used. See [Section 27.0 “Master Synchronous Serial Port \(MSSP\) Module”](#) for more information.

### 3.10.2 DEVICE ENABLE

A GPIO pin can be configured to be a device enable pin. By configuring the pin as an input, the PORT register or the interrupt on change (IOC) can be used to enable the device. [Example 3-2](#) shows how to configure a GPIO as an enable pin by testing the PORT register.

### EXAMPLE 3-2: CONFIGURING GPA3 AS DEVICE ENABLE

```

BANKSEL    TRISGPA
BSF        TRISGPA, 3    ;Set GPA3 as input
BANKSEL    ANSELA
BCF        ANSELA, 3    ;Set GPA3 as digital input
:
:                        ;Insert additional user code here
:
WAIT_ENABLE:
BANKSEL    PORTGPA
BTFSS     PORTGPA, 3    ;Test GPA3 to see if pulled high
:          ;A high on GPA3 indicated device to be enabled
GOTO      WAIT_ENABLE  ;Stay in loop waiting for device enable
BANKSEL    ATSTCON
BSF        ATSTCON, 0   ;Enable the device by enabling drivers
:
:                        ;Insert additional code here
:
    
```

# MCP19110/11

## 3.10.3 OUTPUT POWER GOOD

The output voltage measured between the +V<sub>SEN</sub> and -V<sub>SEN</sub> pins can be monitored by the internal ADC. In firmware, when this ADC reading matches a user-defined power good value, a GPIO can be toggled to indicate the system output voltage is within a specified range. Delays, hysteresis and time-out values can all be configured in firmware.

## 3.10.4 OUTPUT VOLTAGE SOFT-START

During start-up, soft start of the output voltage is accomplished in firmware. By using one of the internal timers and incrementing the OVCCON or OVFCON register on a timer overflow, very long soft start times can be achieved.

## 3.10.5 OUTPUT VOLTAGE TRACKING

The MCP19110/11 can be configured to track another voltage signal at start-up or shutdown. The ADC is configured to read a GPIO that has the desired tracking voltage applied to it. The firmware then handles the tracking of the internal output voltage reference to this ADC reading.

## 3.10.6 MULTI-PHASE SYSTEM

In a multi-phase system, the output of each converter is connected together. There is one master device that sets the system switching frequency and provides each slave device with an error signal, in order to regulate the output to the same value.

The MCP19110/11 can be configured as a multi-phase master or slave by the setting of the MLTPH<2:0> bits in the BUFFCON register ([Register 8-2](#)). When set as a multi-phase master device, the internal switching frequency clock is connected to GPA1 and the output of the error amplifier is connected to GPB1. The GPIOs need to be configured as outputs.

When set as a multi-phase slave device, the GPA1 pin is configured as the CLKPIN function. The switching frequency clock from the master device must be connected to GPA1. The slave device will synchronize its internal switching frequency clock to the master clock. Phase shift can be applied by setting the PWMPHL register of the slave device. The slave GPB1 pin is configured as the error signal input pin (EAPIN). The master error amplifier output must be connected to GPB1. Gain can be added to the master error amplifier output signal by the SLVGNCON register setting ([Register 6-8](#)). The slave device will use this master error signal to regulate the output voltage. When set as a slave device, GPA1 and GPB1 need to be configured as inputs. Refer to [Section 26.1 “Standard Pulse-Width Modulation \(PWM\) Mode”](#) for additional information.

**Note 1:** The ALT\_CLKPIN can also be used by setting the APFCON<CLKSEL> bit. This function is only available in the MCP19111.

## 3.10.7 MULTIPLE OUTPUT SYSTEM

In a multiple output system, the switching frequency of each converter should be synchronized to a master clock to prevent beat frequencies from developing. Phase shift is often added to the master clock to help smooth the system input current. The MCP19110/11 has the ability to function as a multiple output master or slave by setting the appropriate MLTPH<2:0> bits in the BUFFCON register ([Register 8-2](#)).

When configured as a multiple output master, the GPA1 pin is set as the CLKPIN output function. The internal switching frequency clock is applied to this pin and is to be connected to the GPA1 pin of the slave units.

When configured as a multiple output slave, the GPA1 pin is set as the CLKPIN input function. The switching frequency clock of the master device is connected to this pin. Phase shift can be applied by appropriately setting the PWMPHL register of the slave device. Refer to [Section 26.1 “Standard Pulse-Width Modulation \(PWM\) Mode”](#).

**Note 1:** The ALT\_CLKPIN can also be used by setting the APFCON<CLKSEL> bit. This function is only available in the MCP19111.

## 3.10.8 SYSTEM BENCH TESTING

The MCP19110/11 is a highly integrated controller. To facilitate system prototyping, various internal signals can be measured by configuring the MCP19110/11 in bench test mode. To accomplish this, the ATSTCON<BNCHEN> bit is set. This configures GPA0 as the ANALOG\_TEST feature. The signals measured on GPA0 are controlled by the ASEL<4:0> bits of the BUFFCON register. See [Section 8.0 “System Bench Testing”](#) for more information.

**Note 1:** The factory-set calibration words are write-protected even when the MCP19110/11 is placed in a Bench Test mode.

## 4.0 ELECTRICAL CHARACTERISTICS

### 4.1 ABSOLUTE MAXIMUM RATINGS (†)

$V_{IN} - V_{GND}$ .....	-0.3V to +32V
$V_{BOOT} - V_{PHASE}$ .....	-0.3V to +6.5V
$V_{PHASE}$ (continuous) .....	GND – 0.3V to +38V
$V_{PHASE}$ (transient < 100 ns) .....	GND – 5.0V to +38V
$V_{DD}$ internally generated .....	+5V $\pm$ 20%
$V_{HDRV}$ , HDRV Pin .....	+ $V_{PHASE} - 0.3V$ to $V_{BOOT} + 0.3V$
$V_{LDRV}$ , LDRV Pin .....	+ $(V_{GND} - 0.3V)$ to $(V_{DD} + 0.3V)$
Voltage on MCLR with respect to GND .....	-0.3V to +13.5V
Maximum Voltage: any other pin .....	+ $(V_{GND} - 0.3V)$ to $(V_{DD} + 0.3V)$
Maximum output current sunk by any single I/O pin .....	25 mA
Maximum output current sourced by any single I/O pin .....	25 mA
Maximum current sunk by all GPIO .....	65 mA
Maximum current sourced by all GPIO .....	65 mA
ESD protection on all pins (HBM) .....	1.0 kV
ESD protection on all pins (MM) .....	100V

† **Notice:** Stresses above those listed under “Maximum Ratings” may cause permanent damage to the device. This is a stress rating only and functional operation of the device at those or any other conditions above those indicated in the operational listings of this specification is not implied. Exposure to maximum rating conditions for extended periods may affect device reliability.

# MCP19110/11

## 4.2 Electrical Characteristics

**Electrical Specifications:** Unless otherwise noted,  $V_{IN} = 12V$ ,  $V_{REF} = 1.2V$ ,  $F_{SW} = 300\text{ kHz}$ ,  $T_A = +25^\circ\text{C}$ . **Boldface** specifications apply over the  $T_A$  range of  $-40^\circ\text{C}$  to  $+125^\circ\text{C}$ .

Parameter	Symbol	Min	Typ	Max	Units	Conditions
<b>Input</b>						
Input Voltage	$V_{IN}$	<b>4.5</b>	—	<b>32</b>	V	
Input Quiescent Current	$I_Q$	—	5	<b>10</b>	mA	Not switching
Shutdown Current	$I_{SHDN}$	—	1.8	<b>2.2</b>	mA	Note 4
Adjustable Input Under-voltage Lockout Range	UVLO	<b>3</b>	—	<b>32</b>	V	VINLVL is a LOG DAC
Input Undervoltage Lockout Hysteresis	UVLO <sub>HYS</sub>	—	13	—	%	Hysteresis applied to adjustable UVLO setpoint
<b>Overcurrent</b>						
Overcurrent Minimum Threshold	OC <sub>MIN</sub>	—	160	—	mV	
Overcurrent Maximum Threshold	OC <sub>MAX</sub>	—	620	—	mV	
Overcurrent Mid-Scale Threshold	OC <sub>MID</sub>	<b>240</b>	400	<b>550</b>	mV	
Overcurrent Step Size	OC <sub>STEP_SIZE</sub>	<b>10</b>	15	<b>20</b>	mV	
Adjustable OC Leading Edge Blanking Minimum Set Point	LEB <sub>min</sub>	—	114	—	ns	
Adjustable OC Leading Edge Blanking Maximum Set Point	LEB <sub>max</sub>	—	780	—	ns	
<b>Current Sense</b>						
Current Sense Minimum AC Gain	$I_{AC\_GAIN}$	—	0	—	dB	
Current Sense Maximum AC Gain	$I_{AC\_GAIN}$	—	22.8	—	dB	
Current Sense AC Gain Mid-Set Point	$I_{AC\_GAIN}$	8.5	11.5	14	dB	
Current Sense AC Gain Step Size	$I_{AC\_GAIN\_STEP}$	—	1.5	—	dB	
Current Sense AC Gain Offset Voltage	$I_{AC\_OFFSET}$	-175	9	135	mV	
Current Sense Minimum DC Gain	$I_{DC\_GAIN}$	—	19.5	—	dB	
Current Sense Maximum DC Gain	$I_{DC\_GAIN}$	—	35.7	—	dB	
Current Sense DC Gain Mid-Set Point	$I_{DC\_GAIN}$	27	28.6	30.3	dB	
Current Sense DC Gain Step Size	$I_{DC\_GAIN\_STEP}$	—	2.3	—	dB	

**Note 1:** Ensured by design. Not production tested.

**2:**  $V_{DD\_OUT}$  is the voltage present at the  $V_{DD}$  pin.  $V_{DD}$  is the internally generated bias voltage.

**3:** This is the total source current for all GPIO pins combined. Individually, each pin can source a maximum of 25 mA.

**4:** PE1 = 0x00h, ABECON = 0x00h, ATSTCON = 0x80h, WPUGPA = 0x00h, WPUGPB = 0x00h, and SLEEP command issued to PIC core, see SECTION 16.0.



## 4.2 Electrical Characteristics (Continued)

<b>Electrical Specifications:</b> Unless otherwise noted, $V_{IN} = 12V$ , $V_{REF} = 1.2V$ , $F_{SW} = 300\text{ kHz}$ , $T_A = +25^\circ\text{C}$ . <b>Boldface</b> specifications apply over the $T_A$ range of $-40^\circ\text{C}$ to $+125^\circ\text{C}$ .						
Parameter	Symbol	Min	Typ	Max	Units	Conditions
Current Sense DC Gain Offset Voltage	$I_{DC\_OFFSET}$	1.4	1.56	1.7	V	
Voltage for Zero Current	VZC	—	1.45	—	V	VZCCON = 0x80h
<b>Voltage Reference</b>						
Adjustable $V_{OUT}$ Range	$V_{OUT\_RANGE}$	<b>0.5</b>	—	<b>3.6</b>	V	$V_{OUT}$ range with no external voltage divider
$V_{OUT}$ Coarse Resolution	$V_{OUT\_COARSE}$	<b>10.8</b>	15.8	<b>25.8</b>	mV	
$V_{OUT}$ Coarse Mid Set Point	$V_{OUT\_COARSE\_MID}$	<b>1.85</b>	2.04	<b>2.25</b>	V	
$V_{OUT}$ Fine Resolution	$V_{OUT\_FINE}$	—	0.8	<b>1</b>	mV	
<b>Output Overvoltage</b>						
Adjustable Overvoltage Range	$OV_{RANGE}$	<b>0</b>	—	<b>4.5</b>	V	
Adjustable Overvoltage Mid-Set Point	$OV_{MID}$	<b>1.8</b>	2	<b>2.3</b>	V	
Adjustable Overvoltage Resolution	$OV_R$	—	15	—	mV	
<b>Output Undervoltage</b>						
Adjustable Undervoltage Range	$UV_{RANGE}$	<b>0</b>	—	<b>4.5</b>		
Adjustable Undervoltage Mid-Set Point	$UV_{MID}$	<b>1.8</b>	2	<b>2.3</b>	V	
Adjustable Undervoltage Resolution	$UV_R$	—	15	—	mV	
<b>Remote Sense Differential Amplifier</b>						
Closed Loop Voltage Gain	$A_{VOL}$	<b>0.95</b>	1	<b>1.05</b>	V/V	
Common Mode Range	$V_{CMR}$	<b>GND – 0.3</b>	—	<b><math>V_{DD} + 1.0</math></b>	V	Note 1
Common Mode Reject Ratio	CMRR	—	57	—	dB	
Differential Amplifier Offset	$V_{OS}$	—	40	—	mV	See <a href="#">Section 9.5 “Calibration Word 5”</a> and <a href="#">Section 9.6 “Calibration Word 6”</a>
<b>Compensation</b>						
Minimum Zero Frequency	$F_{ZERO\_MIN}$	—	350	—	Hz	
Maximum Zero Frequency	$F_{ZERO\_MAX}$	—	35000	—	Hz	
Minimum Error Amplifier Gain	$G_{EA\_MIN}$	—	0	—	dB	
Maximum Error Amplifier Gain	$G_{EA\_MAX}$	—	36.15	—	dB	

**Note 1:** Ensured by design. Not production tested.

**2:**  $V_{DD-OUT}$  is the voltage present at the  $V_{DD}$  pin.  $V_{DD}$  is the internally generated bias voltage.

**3:** This is the total source current for all GPIO pins combined. Individually, each pin can source a maximum of 25 mA.

**4:** PE1 = 0x00h, ABECON = 0x00h, ATSTCON = 0x80h, WPUGPA = 0x00h, WPUGPB = 0x00h, and SLEEP command issued to PIC core, see SECTION 16.0.

# MCP19110/11

## 4.2 Electrical Characteristics (Continued)

<b>Electrical Specifications:</b> Unless otherwise noted, $V_{IN} = 12V$ , $V_{REF} = 1.2V$ , $F_{SW} = 300\text{ kHz}$ , $T_A = +25^\circ\text{C}$ . <b>Boldface</b> specifications apply over the $T_A$ range of $-40^\circ\text{C}$ to $+125^\circ\text{C}$ .						
Parameter	Symbol	Min	Typ	Max	Units	Conditions
<b>Oscillator</b>						
Internal Oscillator Frequency	$F_{OSC}$	<b>7.60</b>	8.00	<b>8.40</b>	MHz	
Switching Frequency	$F_{SW}$	—	$F_{OSC}/N$	—	kHz	
Switching Frequency Range Select	N	<b>5</b>	—	<b>80</b>		
Maximum Duty Cycle		—	$(N-1)/N$	—	%/100	
<b>Dead Time Adjustment</b>						
Dead Time Step Size	$DT_{STEP}$	—	4	—	ns	
<b>HDRV Output Driver</b>						
HDRV Source Resistance	$R_{HDRV-SCR}$	—	1	<b>2.6</b>	$\Omega$	Measured at 500 mA <a href="#">Note 1</a> , High Range
		—	2	<b>3.5</b>	$\Omega$	Measured at 500 mA <a href="#">Note 1</a> , Low Range
HDRV Sink Resistance	$R_{HDRV-SINK}$	—	1	<b>2.6</b>	$\Omega$	Measured at 500 mA <a href="#">Note 1</a> , High Range
		—	2	<b>3.5</b>	$\Omega$	Measured at 500 mA <a href="#">Note 1</a> , Low Range
HDRV Source Current	$I_{HDRV-SCR}$	—	2	—	A	<a href="#">Note 1</a> , High Range
		—	1	—	A	<a href="#">Note 1</a> , Low Range
HDRV Sink Current	$I_{HDRV-SINK}$	—	2	—	A	<a href="#">Note 1</a> , High Range
		—	1	—	A	<a href="#">Note 1</a> , Low Range
HDRV Rise Time	$t_{RH}$	—	15	<b>30</b>	ns	<a href="#">Note 1</a> , $C_{LOAD} = 3.3\text{ nF}$ , High Range
HDRV Fall Time	$t_{FH}$	—	15	<b>30</b>	ns	<a href="#">Note 1</a> , $C_{LOAD} = 3.3\text{ nF}$ , High Range
<b>LDRV Output Driver</b>						
LDRV Source Resistance	$R_{LDRV-SCR}$	—	1	<b>2.5</b>	$\Omega$	Measured at 500 mA <a href="#">Note 1</a>
LDRV Sink Resistance	$R_{LDRV-SINK}$	—	0.5	<b>1.0</b>	$\Omega$	Measured at 500 mA <a href="#">Note 1</a>
LDRV Source Current	$I_{LDRV-SCR}$	—	2	—	A	<a href="#">Note 1</a>
LDRV Sink Current	$I_{LDRV-SINK}$	—	4	—	A	<a href="#">Note 1</a>
LDRV Rise Time	$t_{RL}$	—	15	<b>30</b>	ns	<a href="#">Note 1</a> , $C_{LOAD} = 3.3\text{ nF}$
LDRV Fall Time	$t_{FL}$	—	7	<b>15</b>	ns	<a href="#">Note 1</a> , $C_{LOAD} = 3.3\text{ nF}$

**Note 1:** Ensured by design. Not production tested.

**2:**  $V_{DD-OUT}$  is the voltage present at the  $V_{DD}$  pin.  $V_{DD}$  is the internally generated bias voltage.

**3:** This is the total source current for all GPIO pins combined. Individually, each pin can source a maximum of 25 mA.

**4:** PE1 = 0x00h, ABECON = 0x00h, ATSTCON = 0x80h, WPUGPA = 0x00h, WPUGPB = 0x00h, and SLEEP command issued to PIC core, see SECTION 16.0.

## 4.2 Electrical Characteristics (Continued)

**Electrical Specifications:** Unless otherwise noted,  $V_{IN} = 12V$ ,  $V_{REF} = 1.2V$ ,  $F_{SW} = 300\text{ kHz}$ ,  $T_A = +25^\circ\text{C}$ . **Boldface** specifications apply over the  $T_A$  range of  $-40^\circ\text{C}$  to  $+125^\circ\text{C}$ .

Parameter	Symbol	Min	Typ	Max	Units	Conditions
<b>Linear Regulator</b>						
Bias Voltage, LDO Output	$V_{DD}$	<b>4.6</b>	5.0	<b>5.4</b>	V	$V_{IN} = 6.0V$ to $32V$ , <a href="#">Note 2</a>
Internal Circuitry Bias Voltage	$AV_{DD}$	—	5.0	—	V	$V_{IN} = 6.0V$ to $32V$ , <a href="#">Note 2</a>
Maximum $V_{DD}$ Output Current	$I_{DD}$	<b>30</b>	—	—	mA	$V_{IN} = 6.0V$ to $20V$ , $V_{DD} = 5.0V$ , <a href="#">Note 2</a>
Line Regulation	$\frac{\Delta V_{DD}}{(V_{DD} \times \Delta V_{IN})}$	—	0.05	<b>0.1</b>	%/V	$(V_{DD} + 1.0V) \leq V_{IN} \leq 20V$ <a href="#">Note 2</a>
Load Regulation	$\Delta V_{DD}/V_{DD}$	<b>-1.75</b>	-0.8	<b>+0.5</b>	%	$I_{DD} = 1\text{ mA}$ to $30\text{ mA}$ <a href="#">Note 2</a>
Output Short Circuit Current	$I_{DD\_SC}$	—	65	—	mA	$V_{IN} = (V_{DD} + 1.0V)$ <a href="#">Note 2</a>
Dropout Voltage	$V_{IN} - V_{DD}$	—	0.5	<b>1</b>	V	$I_{DD} = 30\text{ mA}$ , $V_{IN} = V_{DD} + 1.0V$ <a href="#">Note 2</a>
Power Supply Rejection Ratio	$PSRR_{LDO}$	—	60	—	dB	$f \leq 1000\text{ Hz}$ , $I_{DD} = 25\text{ mA}$ , $C_{IN} = 0\text{ }\mu\text{F}$ , $C_{DD} = 1\text{ }\mu\text{F}$
Band Gap Voltage	BG	<b>-2.5%</b>	1.23	<b>+2.5%</b>	V	
<b>GPIO Pins</b>						
Maximum GPIO Sink Current	$I_{SINK\_GPIO}$	—	—	90	mA	<a href="#">Note 3</a> , <a href="#">Note 1</a>
Maximum GPIO Source Current	$I_{SOURCE\_GPIO}$	—	—	90	mA	<a href="#">Note 3</a> , <a href="#">Note 1</a>
GPIO Weak Pull-up Current	$I_{PULL-UP\_GPIO}$	50	250	400	$\mu\text{A}$	$V_{DD} = 5V$
GPIO Output Low Voltage	$V_{OL}$	—	—	0.6	V	$I_{OL} = 7\text{ mA}$ , $V_{DD} = 5V$ , $T_A = +90^\circ\text{C}$
GPIO Output High Voltage	$V_{OH}$	$V_{DD} - 0.7$	—	—	V	$I_{OH} = -2.5\text{ mA}$ , $V_{DD} = 5V$ , $T_A = +90^\circ\text{C}$
GPIO Input Leakage Current	$GPIO\_I_{IL}$	—	$\pm 0.1$	$\pm 1$	$\mu\text{A}$	Negative current is defined as current sourced by the pin, $T_A = +90^\circ\text{C}$
GPIO Input Low Voltage	$V_{IL}$	GND	—	0.8	V	I/O Port with TTL buffer $V_{DD} = 5V$ , $T_A = +90^\circ\text{C}$
		GND		$0.2V_{DD}$	V	I/O Port with Schmitt Trigger buffer, $V_{DD} = 5V$ , $T_A = +90^\circ\text{C}$
		GND		$0.2V_{DD}$	V	$\overline{MCLR}$ , $T_A = +90^\circ\text{C}$

**Note 1:** Ensured by design. Not production tested.

**2:**  $V_{DD\_OUT}$  is the voltage present at the  $V_{DD}$  pin.  $V_{DD}$  is the internally generated bias voltage.

**3:** This is the total source current for all GPIO pins combined. Individually, each pin can source a maximum of 25 mA.

**4:** PE1 = 0x00h, ABECON = 0x00h, ATSTCON = 0x80h, WPUGPA = 0x00h, WPUGPB = 0x00h, and SLEEP command issued to PIC core, see SECTION 16.0.

# MCP19110/11

## 4.2 Electrical Characteristics (Continued)

**Electrical Specifications:** Unless otherwise noted,  $V_{IN} = 12V$ ,  $V_{REF} = 1.2V$ ,  $F_{SW} = 300\text{ kHz}$ ,  $T_A = +25^\circ\text{C}$ . **Boldface** specifications apply over the  $T_A$  range of  $-40^\circ\text{C}$  to  $+125^\circ\text{C}$ .

Parameter	Symbol	Min	Typ	Max	Units	Conditions
GPIO Input High Voltage	$V_{IH}$	2.0	—	$V_{DD}$	V	I/O Port with TTL buffer, $V_{DD} = 5V$ , $T_A = +90^\circ\text{C}$
		$0.8V_{DD}$	—	$V_{DD}$	V	I/O Port with Schmitt Trigger buffer, $V_{DD} = 5V$ , $T_A = +90^\circ\text{C}$
		$0.8V_{DD}$	—	$V_{DD}$	V	MCLR, $T_A = +90^\circ\text{C}$
<b>Thermal Shutdown</b>						
Thermal Shutdown	$T_{SHD}$	—	160	—	$^\circ\text{C}$	
Thermal Shutdown Hysteresis	$T_{SHD\_HYS}$	—	20	—	$^\circ\text{C}$	

- Note 1:** Ensured by design. Not production tested.  
**Note 2:**  $V_{DD\_OUT}$  is the voltage present at the  $V_{DD}$  pin.  $V_{DD}$  is the internally generated bias voltage.  
**Note 3:** This is the total source current for all GPIO pins combined. Individually, each pin can source a maximum of 25 mA.  
**Note 4:** PE1 = 0x00h, ABECON = 0x00h, ATSTCON = 0x80h, WPUGPA = 0x00h, WPUGPB = 0x00h, and SLEEP command issued to PIC core, see SECTION 16.0.

## 4.3 Thermal Specifications

Parameter	Symbol	Min	Typ	Max	Units	Test Conditions
<b>Temperature Ranges</b>						
Specified Temperature Range	$T_A$	-40	—	+125	$^\circ\text{C}$	
Operating Temperature Range	$T_A$	-40	—	+125	$^\circ\text{C}$	
Maximum Junction Temperature	$T_J$	—	—	+150	$^\circ\text{C}$	
Storage Temperature Range	$T_A$	-65	—	+150	$^\circ\text{C}$	
<b>Thermal Package Resistances</b>						
Thermal Resistance, 24L-QFN 4x4	$\theta_{JA}$	—	42	—	$^\circ\text{C/W}$	
Thermal Resistance, 28L-QFN 5x5	$\theta_{JA}$	—	35.3	—	$^\circ\text{C/W}$	

## 5.0 DIGITAL ELECTRICAL CHARACTERISTICS

### 5.1 Timing Parameter Symbology

The timing parameter symbols have been created with one of the following formats:

- |             |           |  |
|-------------|-----------|--|
| 1. TppS2ppS | 3. TCC:ST | (I <sup>2</sup> C specifications only) |
| 2. TppS     | 4. Ts     | (I <sup>2</sup> C specifications only) |

<b>T</b>		
F	Frequency	TTime

Lowercase letters (pp) and their meanings:

<b>pp</b>			
cc	CCP1	osc	OSC1
ck	CLKOUT	rd	$\overline{RD}$
cs	$\overline{CS}$	rw	$\overline{RD}$ or $\overline{WR}$
di	SDI	sc	SCK
do	SDO	ss	$\overline{SS}$
dt	Data in	t0	T0CKI
io	I/O port	t1	T1CKI
mc	$\overline{MCLR}$	wr	$\overline{WR}$

Uppercase letters and their meanings:

<b>S</b>			
F	Fall	P	Period
H	High	R	Rise
I	Invalid (high-impedance)	V	Valid
L	Low	Z	High-impedance
<b>I<sup>2</sup>C only</b>			
AA	Output access	High	High
BUF	Bus free	Low	Low

TCC:ST (I<sup>2</sup>C specifications only)

<b>CC</b>			
HD	Hold	SU	Setup
<b>ST</b>			
DAT	DATA input hold	STO	STOP condition
STA	START condition		

**FIGURE 5-1: LOAD CONDITIONS**

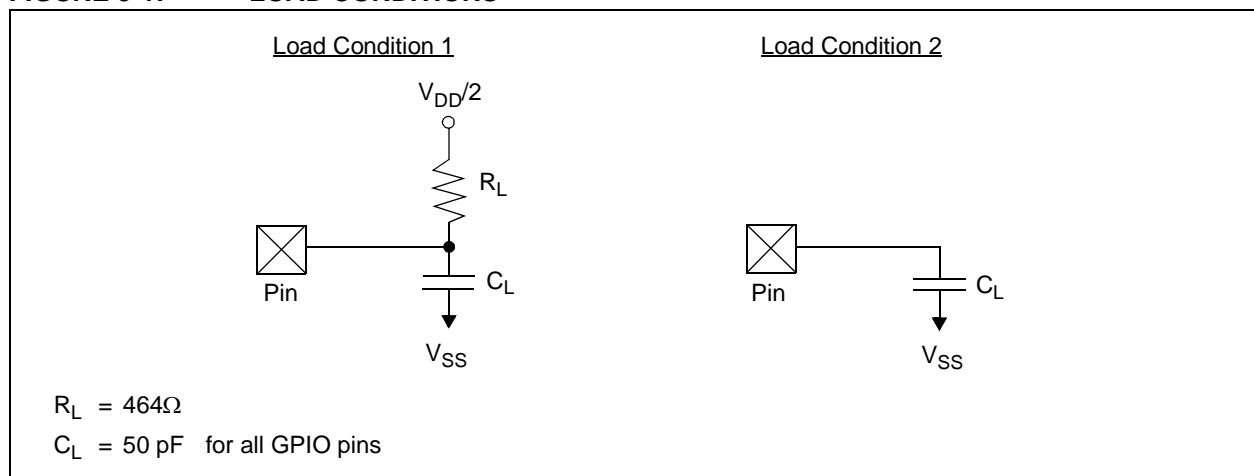

# MCP19110/11

## 5.2 AC Characteristics: MCP19110/11 (Industrial, Extended)

**FIGURE 5-2: EXTERNAL CLOCK TIMING**

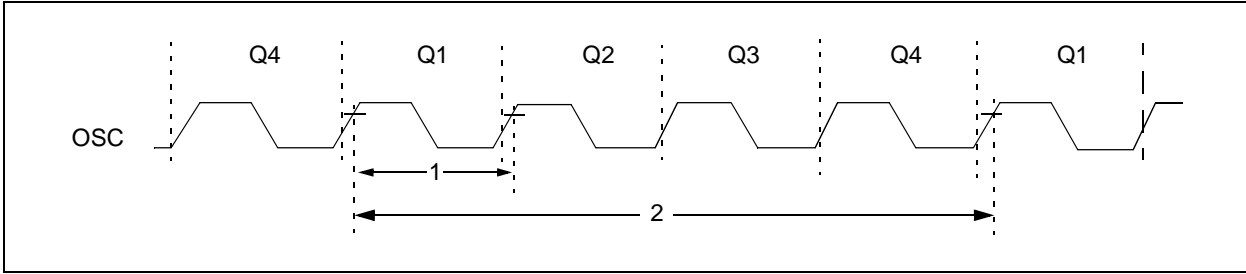

**TABLE 5-1: EXTERNAL CLOCK TIMING REQUIREMENTS**

Param No.	Sym	Characteristic	Min	Typ <sup>†</sup>	Max	Units	Conditions
	$F_{OSC}$	Oscillator Frequency <sup>(1)</sup>	—	8	—	MHz	
1	$T_{OSC}$	Oscillator Period <sup>(1)</sup>	—	250	—	ns	
2	$T_{CY}$	Instruction Cycle Time <sup>(1)</sup>	—	1000	—	ns	

\* These parameters are characterized but not tested.

† Data in “Typ” column is at  $V_{IN} = 12V$  ( $V_{DD} = 5V$ ), +25°C unless otherwise stated. These parameters are for design guidance only and are not tested.

**Note 1:** Instruction cycle period ( $T_{CY}$ ) equals four times the input oscillator time base period. All specified values are based on characterization data for that particular oscillator type under standard operating conditions with the device executing code.

**FIGURE 5-3: CLKOUT AND I/O TIMING**

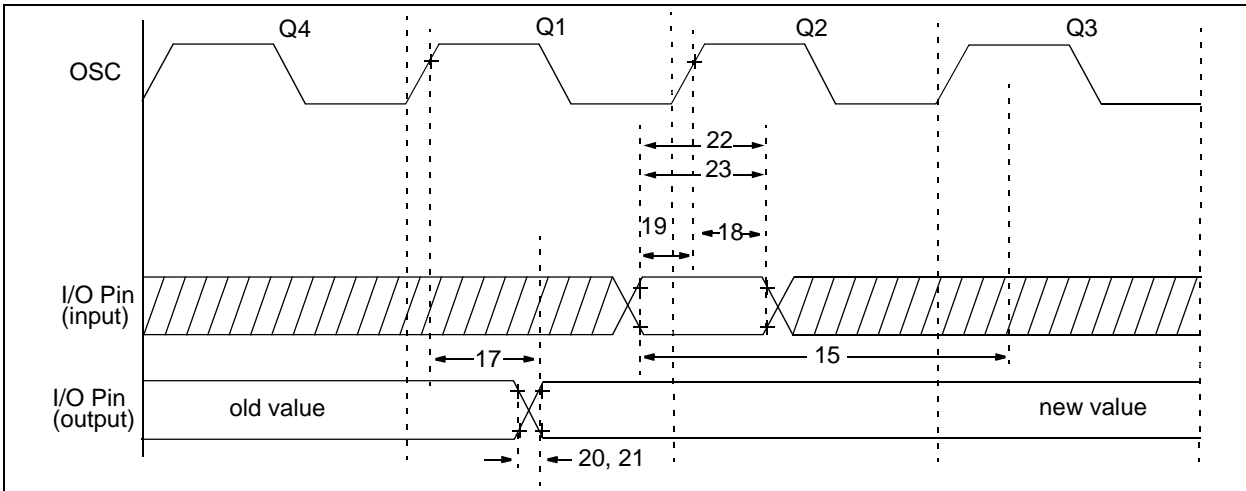

**TABLE 5-2: CLKOUT AND I/O TIMING REQUIREMENTS**

Param No.	Sym	Characteristic	Min	Typ†	Max	Units	Conditions
17	TosH2ioV	OSC1↑ (Q1 cycle) to Port out valid	—	50	150*	ns	
		Port out valid	—	—	300	ns	
18	TosH2ioI	OSC1↑ (Q2 cycle) to Port input invalid (I/O in hold time)	100	—	—	ns	
19	TioV2osH	Port input valid to OSC1↑ (I/O in setup time)	0	—	—	ns	
20	TioR	Port output rise time	—	10	40	ns	
21	TioF	Port output fall time	—	10	40	ns	
22	Tinp	INT pin high	25	—	—	ns	
22A		or low time	40	—	—	ns	
23	Trbp	Port A change INT	Tcy	—	—	ns	
23A	Trbp	high or low time					

\* These parameters are characterized but not tested.

† Data in "Typ" column is at  $V_{IN} = 12V$  ( $V_{DD} = 5V$ ),  $+25^{\circ}C$  unless otherwise stated.

**FIGURE 5-4: RESET, WATCHDOG TIMER, OSCILLATOR START-UP TIMER AND POWER-UP TIMER TIMING**

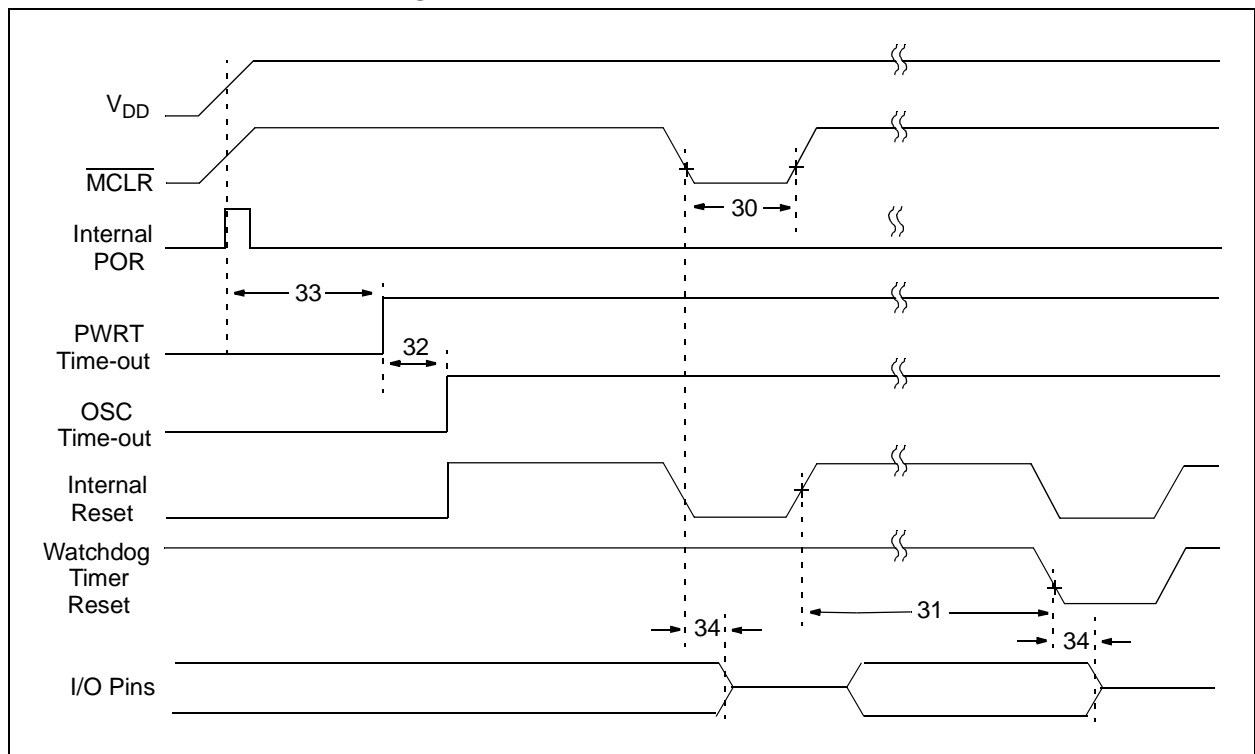

# MCP19110/11

**TABLE 5-3: RESET, WATCHDOG TIMER, OSCILLATOR START-UP TIMER, AND POWER-UP TIMER REQUIREMENTS**

Param No.	Sym	Characteristic	Min	Typ <sup>†</sup>	Max	Units	Conditions
30	T <sub>MCLR</sub>	MCLR Pulse Width (low)	2	—	—	μs	V <sub>DD</sub> = 5V, -40°C to +85°C
31	T <sub>WDT</sub>	Watchdog Timer Time-out Period (No Prescaler)	7	18	33	ms	V <sub>DD</sub> = 5V, -40°C to +85°C
32	T <sub>OST</sub>	Oscillation Start-up Timer Period	—	1024T <sub>OSC</sub>	—	—	T <sub>OSC</sub> = OSC1 period
33*	T <sub>PWRT</sub>	Power-up Timer Period (4 x T <sub>WDT</sub> )	28	64	132	ms	V <sub>DD</sub> = 5V, -40°C to +85°C
34	T <sub>IOZ</sub>	I/O high-impedance from $\overline{\text{MCLR}}$ Low or Watchdog Timer Reset	—	—	2.0	μs	

\* These parameters are characterized but not tested.

† Data in "Typ" column is at V<sub>IN</sub> = 12V (V<sub>DD</sub> = 5V), +25°C unless otherwise stated. These parameters are for design guidance only and are not tested.

**FIGURE 5-5: TIMER0 AND TIMER1 EXTERNAL CLOCK TIMINGS**

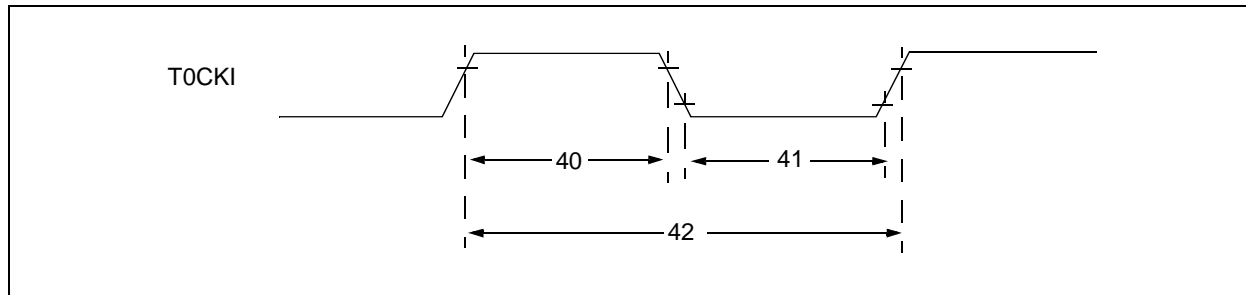

**TABLE 5-4: TIMER0 AND TIMER1 EXTERNAL CLOCK REQUIREMENTS**

Param No.	Sym	Characteristic	Min	Typ <sup>†</sup>	Max	Units	Conditions
40*	Tt0H	TOCKI High Pulse Width	No Prescaler	0.5T <sub>CY</sub> + 20	—	—	ns
			With Prescaler	10	—	—	ns
41*	Tt0L	TOCKI Low Pulse Width	No Prescaler	0.5T <sub>CY</sub> + 20	—	—	ns
			With Prescaler	10	—	—	ns
42*	Tt0P	TOCKI Period	Greater of: 20 or $\frac{T_{CY} + 40}{N}$	—	—	ns	N = prescale value (2, 4, ..., 256)

\* These parameters are characterized but not tested.

† Data in "Typ" column is at V<sub>IN</sub> = 12V (V<sub>DD</sub> = 5V), +25°C unless otherwise stated. These parameters are for design guidance only and are not tested.



**FIGURE 5-6: PWM TIMING**

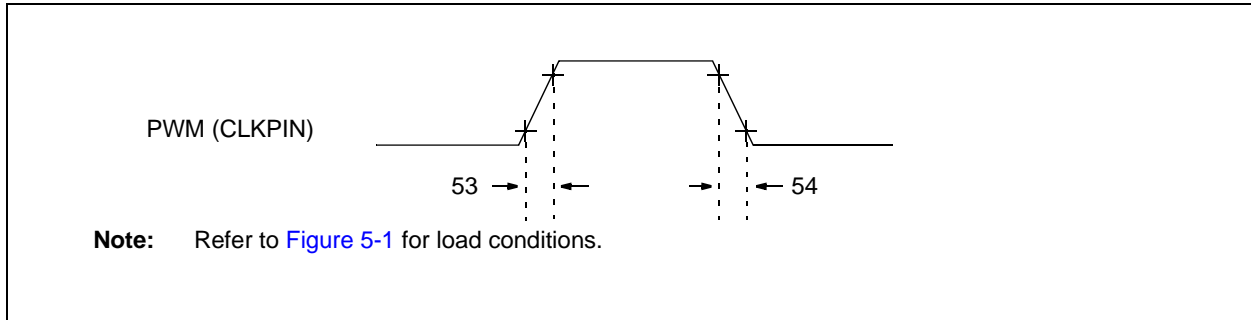

**TABLE 5-5: PWM REQUIREMENTS**

Param No.	Sym	Characteristic	Min	Typ†	Max	Units	Conditions
53*	TccR	PWM (CLKPIN) output rise time	—	10	25	ns	
54*	TccF	PWM (CLKPIN) output fall time	—	10	25	ns	

\* These parameters are characterized but not tested.

† Data in “Typ” column is at  $V_{IN} = 12V$  ( $V_{DD} = 5V$ ),  $+25^{\circ}C$  unless otherwise stated. Parameters are for design guidance only and are not tested.

**TABLE 5-6: MCP19110/11 A/D CONVERTER (ADC) CHARACTERISTICS:**

Standard Operating Conditions (unless otherwise stated)							
Operating temperature $-40^{\circ}C \leq T_A \leq +125^{\circ}C$							
Param No.	Sym	Characteristic	Min	Typ†	Max	Units	Conditions
AD01	$N_R$	Resolution	—	—	10	bit	
AD02	$E_{IL}$	Integral Error	—	—	$\pm 1$	LSb	$AV_{DD} = 5.0V$
AD03	$E_{DL}$	Differential Error	—	—	$\pm 1$	LSb	No missing codes to 10 bits $AV_{DD} = 5.0V$
AD04	$E_{OFF}$	Offset Error	—	+3.0	+5.0	LSb	$AV_{DD} = 5.0V$
AD07	$E_{GN}$	Gain Error	—	$\pm 2$	$\pm 5$	LSb	$AV_{DD} = 5.0V$
AD06 AD06A	$V_{REF}$	Reference Voltage <sup>(3)</sup>	—	$AV_{DD}$	—	V	
AD07	$V_{AIN}$	Full-Scale Range	GND	—	$AV_{DD}$	V	
AD08	$Z_{AIN}$	Recommended Impedance of Analog Voltage Source	—	—	10	k $\Omega$	

\* These parameters are characterized but not tested.

† Data in ‘Typ’ column is at  $V_{IN} = 12V$  ( $V_{DD} = 5V$ ),  $+25^{\circ}C$  unless otherwise stated. These parameters are for design guidance only and are not tested.

**Note 1:** Total Absolute Error includes integral, differential, offset and gain errors.

**2:** The A/D conversion result never decreases with an increase in the input voltage and has no missing codes.

**3:** When ADC is off, it will not consume any current other than leakage current. The power-down current specification includes any such leakage from the ADC module.

# MCP19110/11

**TABLE 5-7: MCP19110/11 A/D CONVERSION REQUIREMENTS**

Standard Operating Conditions (unless otherwise stated) Operating temperature $-40^{\circ}\text{C} \leq T_A \leq +125^{\circ}\text{C}$							
Param No.	Sym	Characteristic	Min	Typ†	Max	Units	Conditions
AD130*	$T_{AD}$	A/D Clock Period	1.6	—	9.0	$\mu\text{s}$	$T_{OSC}$ -based, $V_{REF} \geq 3.0\text{V}$
			3.0	—	9.0	$\mu\text{s}$	$T_{OSC}$ -based, $V_{REF}$ full range
		A/D Internal RC Oscillator Period	3.0	6.0	9.0	$\mu\text{s}$	ADCS<1:0> = 11 (ADRC mode) At $V_{DD} = 2.5\text{V}$
			1.6	4.0	6.0	$\mu\text{s}$	At $V_{DD} = 5.0\text{V}$
AD131	$T_{CNV}$	Conversion Time (not including Acquisition Time) <sup>(1)</sup>	—	11	—	$T_{AD}$	Set GO/DONE bit to new data in A/D Result register
AD132*	$T_{ACQ}$	Acquisition Time	—	11.5	—	$\mu\text{s}$	
AD133*	$T_{AMP}$	Amplifier Settling Time	—	—	5	$\mu\text{s}$	
AD134	$T_{GO}$	Q4 to A/D Clock Start	—	$T_{OSC}/2$	—	—	If the A/D clock source is selected as RC, a time of $T_{CY}$ is added before the A/D clock starts. This allows the SLEEP instruction to be executed.
			—	$T_{OSC}/2 + T_{CY}$	—	—	

\* These parameters are characterized but not tested.

† Data in 'Typ' column is at  $V_{IN} = 12\text{V}$  ( $V_{DD} = 5\text{V}$ ),  $+25^{\circ}\text{C}$  unless otherwise stated. These parameters are for design guidance only and are not tested.

**Note 1:** ADRESH and ADRESL registers may be read on the following  $T_{CY}$  cycle.

**FIGURE 5-7: A/D CONVERSION TIMING (NORMAL MODE)**

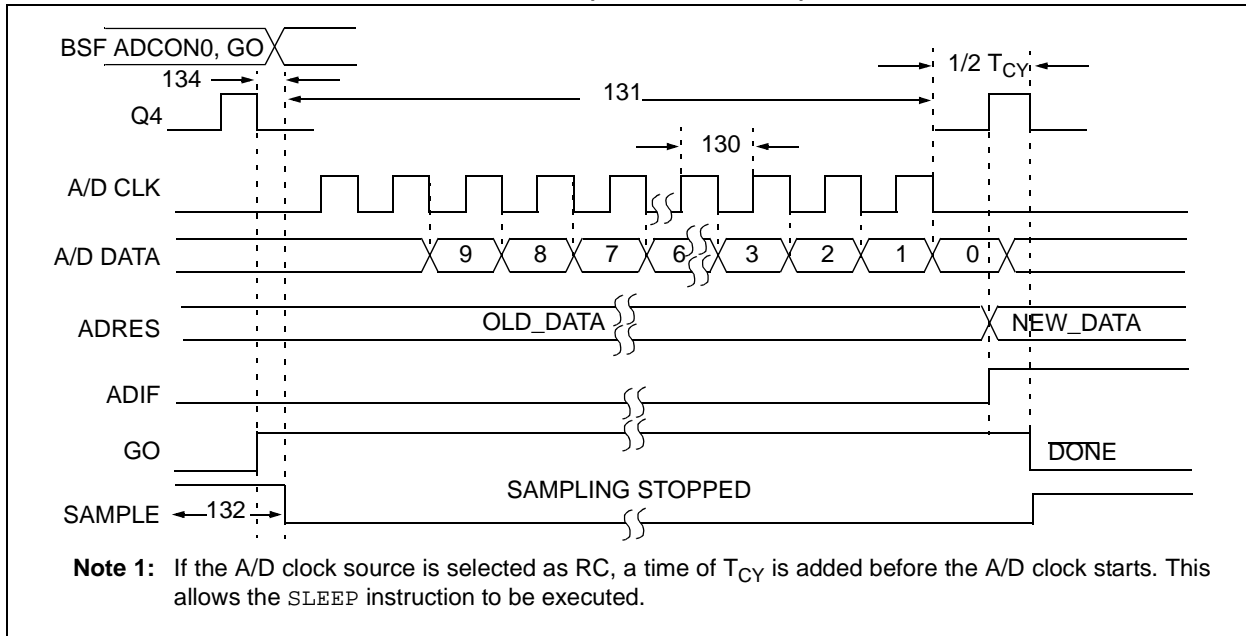

**FIGURE 5-8: A/D CONVERSION TIMING (SLEEP MODE)**

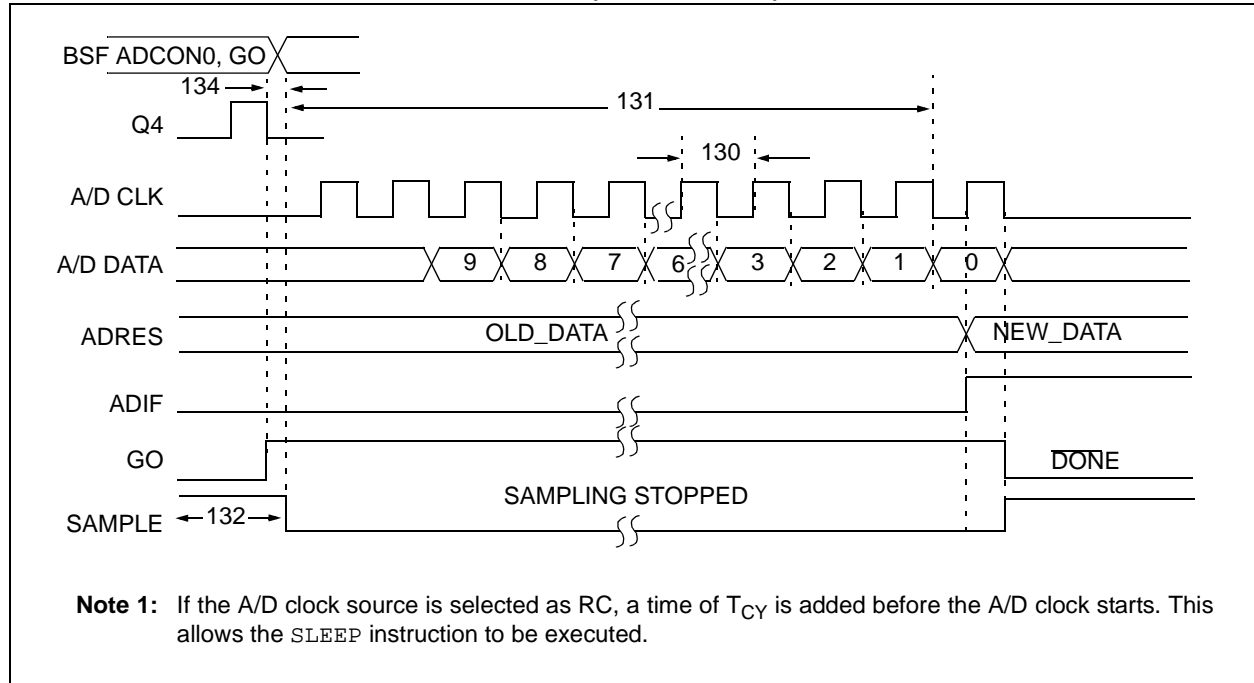

# MCP19110/11

---

NOTES:

## 6.0 CONFIGURING THE MCP19110/11

The MCP19110/11 is an analog controller with digital peripheral. This means that device configuration is handled through register settings instead of adding external components. The following sections detail how to set the analog control registers.

The VINLVL<UVLOEN> bit must be set to enable the input Undervoltage Lockout circuitry.

**Note:** The VINIF interrupt flag bit is set when an interrupt condition occurs, regardless of the state of its corresponding enable bit or the Global Enable bit, GIE, of the INTCON register.

### 6.1 Input Undervoltage Lockout

The VINLVL register contains the digital value that sets the input Undervoltage Lockout. When the input voltage on the V<sub>IN</sub> pin to the MCP19110/11 is below this programmed level, the INTCON<VINIF> flag will be set. This bit is automatically cleared when the MCP19110/11 V<sub>IN</sub> voltage rises above this programmed level.

#### REGISTER 6-1: VINLVL: INPUT UNDERVOLTAGE LOCKOUT CONTROL REGISTER

R/W-0	U-0	R/W-x	R/W-x	R/W-x	R/W-x	R/W-x	R/W-x
UVLOEN	—	UVLO5	UVLO4	UVLO3	UVLO2	UVLO1	UVLO0
bit 7							bit 0

#### Legend:

R = Readable bit	W = Writable bit	U = Unimplemented bit, read as '0'
-n = Value at POR	'1' = Bit is set	'0' = Bit is cleared
		x = Bit is unknown

bit 7      **UVLOEN:** Undervoltage Lockout DAC Control bit  
           1 = Undervoltage Lockout DAC is enabled  
           0 = Undervoltage Lockout DAC is disabled

bit 6      **Unimplemented:** Read as '0'

bit 5-0    **UVLO<5:0>:** Undervoltage Lockout Configuration bits  
 $UVLO<5:0> = 26.5 \cdot \ln(UVLO_{SET\_POINT}/4)$

# MCP19110/11

---

## 6.2 Output Overcurrent

The MCP19110/11 features a cycle-by-cycle peak current limit. By monitoring the OCIF interrupt flag, custom overcurrent fault handling can be implemented.

To detect an output overcurrent, the MCP19110/11 senses the voltage drop across the high-side MOSFET while it is conducting. Leading edge blanking is incorporated to mask the overcurrent measurement for a given amount of time. This helps prevent false overcurrent readings. When the input voltage is greater than 20V, or if the  $R_{DS(ON)}$  of the high-side MOSFET is such that the programmed overcurrent threshold does not produce acceptable peak overcurrent protection, an alternative method must be used to determine an output overcurrent situation. An alternative technique can use the configurable output undervoltage protection and the PE1<UVTEE> bit to quickly terminate switching when the output voltage drops because of an overcurrent event.

When an output overcurrent is sensed, the OCIF flag is set and the high-side drive signal is immediately terminated. Without any custom overcurrent handling implemented, the high-side drive signal will be asserted high at the beginning of the next clock cycle. If the overcurrent condition still exists, the high-drive signal will again be terminated.

The OCIF interrupt flag must be cleared in software. However, if a subsequent switching cycle without an overcurrent condition has not occurred, hardware will immediately set the OCIF interrupt flag.

Register OCCON contains the bits used to configure both the output overcurrent limit and the amount of leading edge blanking (see [Register 6-2](#)).

The OCCON<OCEN> bit must be set to enable the input overcurrent circuitry.

<p><b>Note:</b> The OCIF interrupt flag bit is set when an interrupt condition occurs, regardless of the state of its corresponding enable bit or the Global Enable bit, GIE, of the INTCON register.</p>
---

## REGISTER 6-2: OCON: OUTPUT OVERCURRENT CONTROL REGISTER

R/W-0	R/W-x	R/W-x	R/W-x	R/W-x	R/W-x	R/W-x	R/W-x
OCEN	OCLEB1	OCLEB0	OOC4	OOC3	OOC2	OOC1	OOC0
bit 7							bit 0

### Legend:

R = Readable bit

W = Writable bit

U = Unimplemented bit, read as '0'

-n = Value at POR

'1' = Bit is set

'0' = Bit is cleared

x = Bit is unknown

- bit 7      **OCEN:** Output Overcurrent DAC Control bit  
 1 = Output Overcurrent DAC is enabled  
 0 = Output Overcurrent DAC is disabled
- bit 6-5    **OCLEB<1:0>:** Leading Edge Blanking  
 00 = 114 ns blanking  
 01 = 213 ns blanking  
 10 = 400 ns blanking  
 11 = 780 ns blanking
- bit 4-0    **OOC<4:0>:** Output Overcurrent Configuration bits  
 00000 = 160 mV drop  
 00001 = 175 mV drop  
 00010 = 190 mV drop  
 00011 = 205 mV drop  
 00100 = 220 mV drop  
 00101 = 235 mV drop  
 00110 = 250 mV drop  
 00111 = 265 mV drop  
 01000 = 280 mV drop  
 01001 = 295 mV drop  
 01010 = 310 mV drop  
 01011 = 325 mV drop  
 01100 = 340 mV drop  
 01101 = 355 mV drop  
 01110 = 370 mV drop  
 01111 = 385 mV drop  
 10000 = 400 mV drop  
 10001 = 415 mV drop  
 10010 = 430 mV drop  
 10011 = 445 mV drop  
 10100 = 460 mV drop  
 10101 = 475 mV drop  
 10110 = 490 mV drop  
 10111 = 505 mV drop  
 11000 = 520 mV drop  
 11001 = 535 mV drop  
 11010 = 550 mV drop  
 11011 = 565 mV drop  
 11100 = 580 mV drop  
 11101 = 595 mV drop  
 11110 = 610 mV drop  
 11111 = 625 mV drop

# MCP19110/11

## 6.3 Current Sense AC Gain

The current measured across the inductor is a square wave that is averaged by the capacitor ( $C_S$ ) connected between  $+I_{SEN}$  and  $-I_{SEN}$ . This very small voltage plus the ripple can be amplified by the current sense AC gain circuitry. The amount of gain is controlled by the CSGSCON register.

**REGISTER 6-3: CSGSCON: CURRENT SENSE AC GAIN CONTROL REGISTER**

U-0	R/W-x	R/W-x	R/W-x	R/W-x	R/W-x	R/W-x	R/W-x
—	Reserved	Reserved	Reserved	CSGS3	CSGS2	CSGS1	CSGS0
bit 7							bit 0

**Legend:**

R = Readable bit

W = Writable bit

U = Unimplemented bit, read as '0'

-n = Value at POR

'1' = Bit is set

'0' = Bit is cleared

x = Bit is unknown

bit 7 **Unimplemented:** Read as '0'

bit 6-4 **Reserved**

bit 3-0 **CSGS<3:0>:** Current Sense AC Gain Setting bits

0000 = 0 dB

0001 = 1.0 dB

0010 = 2.5 dB

0011 = 4.0 dB

0100 = 5.5 dB

0101 = 7.0 dB

0110 = 8.5 dB

0111 = 10.0 dB

1000 = 11.5 dB

1001 = 13.0 dB

1010 = 14.5 dB

1011 = 16.0 dB

1100 = 17.5 dB

1101 = 19.0 dB

1110 = 20.5 dB

1111 = 22.0 dB



## 6.4 Current Sense DC Gain

DC gain can be added to the sensed inductor current to allow it to be read by the ADC. The amount of DC gain added is controlled by the CSDGCON register.

Adding DC gain to the current sense signal used by the control loop may also be needed in some multi-phase systems to account for device and component differences. The CSDGEN bit determines if the gained current sense signal is added back to the AC current signal (see [Register 6-4](#)). If the CSDGEN bit is cleared, DC gain can still be added, but the gained signal is not added back to the AC current signal.

**REGISTER 6-4: CSDGCON: CURRENT SENSE DC GAIN CONTROL REGISTER**

R/W-0	U-0	U-0	U-0	R/W-x	R/W-x	R/W-x	R/W-x
CSDGEN	—	—	—	Reserved	CSDG2	CSDG1	CSDG0
bit 7				bit 0			

**Legend:**

R = Readable bit	W = Writable bit	U = Unimplemented bit, read as '0'
-n = Value at POR	'1' = Bit is set	'0' = Bit is cleared      x = Bit is unknown

- bit 7      **CSDGEN:** Current Sense DC Gain Enable bit  
1 = DC gain current sense signal used in control loop.  
0 = DC gain current sense signal only read by ADC.
- bit 6-4    **Unimplemented:** Read as '0'
- bit 3      **Reserved**
- bit 2-0    **CSDG<2:0>:** Current Sense DC Gain Setting bits  
000 = 19.5 dB  
001 = 21.8 dB  
010 = 24.1 dB  
011 = 26.3 dB  
100 = 28.6 dB  
101 = 30.9 dB  
110 = 33.2 dB  
111 = 35.7 dB

# MCP19110/11

## 6.5 Voltage for Zero Current

In multi-phase systems it may be necessary to provide some offset to the sensed inductor current. The VZCCON register can be used to provide a positive or negative offset in the sensed current. Typically, the VZCCON will be set to 0x80h, which corresponds to the sensed inductor current centered around 1.45V. However, by adjusting the VZCCON register, this centered voltage can be shifted up or down by approximately 3.28 mV per step.

**REGISTER 6-5: VZCCON: VOLTAGE FOR ZERO CURRENT CONTROL REGISTER**

R/W-x	R/W-x	R/W-x	R/W-x	R/W-x	R/W-x	R/W-x	R/W-x
VZC7	VZC6	VZC5	VZC4	VZC3	VZC2	VZC1	VZC0
bit 7							bit 0

**Legend:**

R = Readable bit	W = Writable bit	U = Unimplemented bit, read as '0'	
-n = Value at POR	'1' = Bit is set	'0' = Bit is cleared	x = Bit is unknown

bit 7-0      **VZC<7:0>**: Voltage for Zero Current Setting bits  
00000000 = -420.00 mV Offset  
00000001 = -416.72 mV Offset  
•  
•  
•  
10000000 = 0 mV Offset  
•  
•  
•  
11111110 = +413.12 mV Offset  
11111111 = +416.40 mV Offset

## 6.6 Compensation Setting

The MCP19110/11 uses a peak current mode control architecture. A control reference is used to regulate the peak current of the converter directly. The inner current loop essentially turns the inductor into a voltage-controlled current source. This reduces the control-to-output transfer function to a simple single-pole model of a current source feeding a capacitor. The desired response of the overall loop can be tuned by proper placement of the compensation zero frequency and gain. Figure 6-1 shows a simplified drawing of the internal compensation. See Register 6-6 for the adjustable zero frequency and gain settings.

**FIGURE 6-1: SIMPLIFIED COMPENSATION**

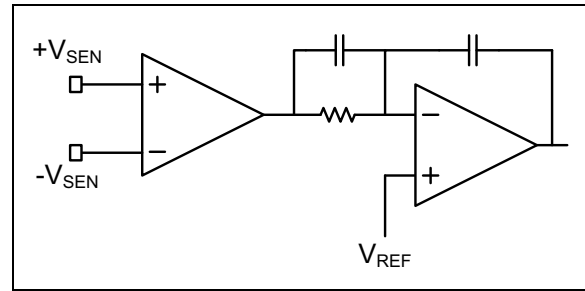

### REGISTER 6-6: CMPZCON: COMPENSATION SETTING CONTROL REGISTER

R/W-x	R/W-x	R/W-x	R/W-x	R/W-x	R/W-x	R/W-x	R/W-x
CMPZF3	CMPZF2	CMPZF1	CMPZF0	CMPZG3	CMPZG2	CMPZG1	CMPZG0
bit 7							bit 0

**Legend:**

R = Readable bit                      W = Writable bit                      U = Unimplemented bit, read as '0'  
 -n = Value at POR                      '1' = Bit is set                      '0' = Bit is cleared                      x = Bit is unknown

bit 7-4                      **CMPZF<3:0>**: Compensation Zero Frequency Setting bits

- 0000 = 1500 Hz
- 0001 = 1850 Hz
- 0010 = 2300 Hz
- 0011 = 2840 Hz
- 0100 = 3460 Hz
- 0101 = 4300 Hz
- 0110 = 5300 Hz
- 0111 = 6630 Hz
- 1000 = 8380 Hz
- 1001 = 9950 Hz
- 1010 = 12200 Hz
- 1011 = 14400 Hz
- 1100 = 18700 Hz
- 1101 = 23000 Hz
- 1110 = 28400 Hz
- 1111 = 35300 Hz

bit 3-0                      **CMPZG<3:0>**: Compensation Gain Setting bits

- 0000 = 36.15 dB
- 0001 = 33.75 dB
- 0010 = 30.68 dB
- 0011 = 28.43 dB
- 0100 = 26.10 dB
- 0101 = 23.81 dB
- 0110 = 21.44 dB
- 0111 = 19.10 dB
- 1000 = 16.78 dB
- 1001 = 14.32 dB
- 1010 = 12.04 dB
- 1011 = 9.54 dB
- 1100 = 7.23 dB
- 1101 = 4.61 dB
- 1110 = 2.28 dB
- 1111 = 0.00 dB

# MCP19110/11

## 6.7 Slope Compensation

A negative voltage slope is added to the output of the error amplifier. This is done to prevent subharmonic instability when:

1. the operating duty cycle is greater than 50%
2. wide changes in the duty cycle occur.

The amount of negative slope added to the error amplifier output is controlled by [Register 6-7](#).

The slope compensation is enabled by setting the SLCPBY bit in the ABECON register.

### REGISTER 6-7: SLPCRCON: SLOPE COMPENSATION RAMP CONTROL REGISTER

R/W-x	R/W-x	R/W-x	R/W-x	R/W-x	R/W-x	R/W-x	R/W-x
SLPG3	SLPG2	SLPG1	SLPG0	SLPS3	SLPS2	SLPS1	SLPS0
bit 7							bit 0

#### Legend:

R = Readable bit

W = Writable bit

U = Unimplemented bit, read as '0'

-n = Value at POR

'1' = Bit is set

'0' = Bit is cleared

x = Bit is unknown

bit 7-4 **SLPG<3:0>**: Slope Compensation Amplitude Configuration bits

0000	= 0.017 $V_{PK-PK}$ , measured for 50% duty cycle waveform
0001	= 0.022 $V_{PK-PK}$ , measured for 50% duty cycle waveform
0010	= 0.030 $V_{PK-PK}$ , measured for 50% duty cycle waveform
0011	= 0.040 $V_{PK-PK}$ , measured for 50% duty cycle waveform
0100	= 0.053 $V_{PK-PK}$ , measured for 50% duty cycle waveform
0101	= 0.070 $V_{PK-PK}$ , measured for 50% duty cycle waveform
0110	= 0.094 $V_{PK-PK}$ , measured for 50% duty cycle waveform
0111	= 0.125 $V_{PK-PK}$ , measured for 50% duty cycle waveform
1000	= 0.170 $V_{PK-PK}$ , measured for 50% duty cycle waveform
1001	= 0.220 $V_{PK-PK}$ , measured for 50% duty cycle waveform
1010	= 0.300 $V_{PK-PK}$ , measured for 50% duty cycle waveform
1011	= 0.400 $V_{PK-PK}$ , measured for 50% duty cycle waveform
1100	= 0.530 $V_{PK-PK}$ , measured for 50% duty cycle waveform
1101	= 0.700 $V_{PK-PK}$ , measured for 50% duty cycle waveform
1110	= 0.940 $V_{PK-PK}$ , measured for 50% duty cycle waveform
1111	= 1.250 $V_{PK-PK}$ , measured for 50% duty cycle waveform

bit 3-0 **SLPS<3:0>**: Slope Compensation  $\Delta V/\Delta t$  Configuration bits

#### 6.7.1 SLPS<3:0> CONFIGURATION

The SLPS<3:0> directly controls the  $\Delta V/\Delta t$  of the added ramp. This byte should be set proportional to the switching frequency according to the following equation:

#### EQUATION 6-1:

$$n = \left( \frac{F_{SW}}{100,000} \right) - 1$$

Where:

$F_{SW}$  = Device switching frequency

n = Decimal equivalent of SLPS<3:0>

#### 6.7.2 SLPG<3:0> CONFIGURATION

The SLPG<3:0> controls the amplitude of the added ramp. The values listed above correspond to a 50% duty cycle waveform and is true only if the SLPS<3:0> bits are set according to the equation in [Section 6.7.1 "SLPS<3:0> Configuration"](#). If less amplitude is required, the SLPS<3:0> bits can be adjusted to a lower switching frequency.

## 6.8 MASTER Error Signal Gain

When operating in a multi-phase system, the output of the MASTER's error amplifier is used by all SLAVE devices as their control signal. It is important to balance the current in all phases to maintain a uniform temperature across all phases. Component tolerances make this balancing difficult. Each SLAVE device has the ability to gain or attenuate the MASTER error signal depending upon the settings of [Register 6-8](#).

**Note:** The SLVGNCON register is configured in the multi-phase SLAVE device.

### REGISTER 6-8: SLVGNCON: MASTER ERROR SIGNAL INPUT GAIN CONTROL REGISTER

U-0	U-0	U-0	R/W-x	R/W-x	R/W-x	R/W-x	R/W-x	
—	—	—	SLVGN4	SLVGN3	SLVGN2	SLVGN1	SLVGN0	
bit 7								bit 0

#### Legend:

R = Readable bit	W = Writable bit	U = Unimplemented bit, read as '0'
-n = Value at POR	'1' = Bit is set	'0' = Bit is cleared
		x = Bit is unknown

bit 7-5      **Unimplemented:** Read as '0'

bit 4-0      **SLVGN<4:0>:** MASTER Error Signal Gain bits

00000	= -3.3 dB
00001	= -3.1 dB
00010	= -2.9 dB
00011	= -2.7 dB
00100	= -2.5 dB
00101	= -2.3 dB
00110	= -2.1 dB
00111	= -1.9 dB
01000	= -1.7 dB
01001	= -1.4 dB
01010	= -1.2 dB
01011	= -1.0 dB
01100	= -0.8 dB
01101	= -0.6 dB
01110	= -0.4 dB
01111	= -0.2 dB
10000	= 0.0 dB
10001	= 0.2 dB
10010	= 0.4 dB
10011	= 0.7 dB
10100	= 0.9 dB
10101	= 1.1 dB
10110	= 1.3 dB
10111	= 1.5 dB
11000	= 1.7 dB
11001	= 1.9 dB
11010	= 2.1 dB
11011	= 2.3 dB
11100	= 2.6 dB
11101	= 2.8 dB
11110	= 3.0 dB
11111	= 3.2 dB

# MCP19110/11

## 6.9 MOSFET Driver Programmable Dead Time

The turn-on delay of the high-side and low-side drive signals can be configured independently to allow different MOSFETs and circuit board layouts to be used to construct an optimized system. See [Figure 6-2](#).

Setting the HDLYBY and LDLYBY bits of the PE1 register enables the high-side and low-side delay, respectively. The amount of delay added is controlled in the DEADCON register. See [Register 6-9](#) for more information.

**FIGURE 6-2: MOSFET DRIVER DEAD TIME**

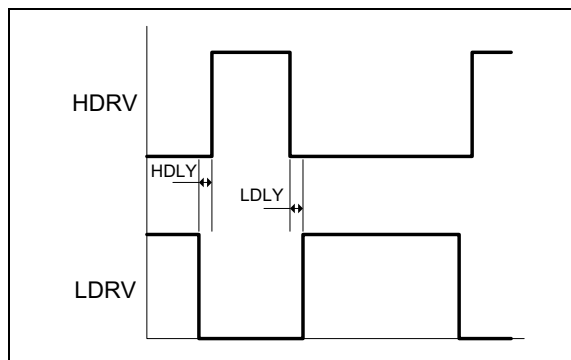

**REGISTER 6-9: DEADCON: DRIVER DEAD TIME CONTROL REGISTER**

R/W-x	R/W-x	R/W-x	R/W-x	R/W-x	R/W-x	R/W-x	R/W-x
HDLY3	HDLY2	HDLY1	HDLY0	LDLY3	LDLY2	LDLY1	LDLY0
bit 7							bit 0

**Legend:**

R = Readable bit                      W = Writable bit                      U = Unimplemented bit, read as '0'  
 -n = Value at POR                      '1' = Bit is set                      '0' = Bit is cleared                      x = Bit is unknown

bit 7-4                      **HDLY<3:0>**: High-Side Dead Time Configuration bits

- 0000 = 11 ns delay
- 0001 = 15 ns delay
- 0010 = 19 ns delay
- 0011 = 23 ns delay
- 0100 = 27 ns delay
- 0101 = 31 ns delay
- 0110 = 35 ns delay
- 0111 = 39 ns delay
- 1000 = 43 ns delay
- 1001 = 47 ns delay
- 1010 = 51 ns delay
- 1011 = 55 ns delay
- 1100 = 59 ns delay
- 1101 = 63 ns delay
- 1110 = 67 ns delay
- 1111 = 71 ns delay

bit 3-0                      **LDLY<3:0>**: Low-Side Dead Time Configuration bits

- 0000 = 4 ns delay
- 0001 = 8 ns delay
- 0010 = 12 ns delay
- 0011 = 16 ns delay
- 0100 = 20 ns delay
- 0101 = 24 ns delay
- 0110 = 28 ns delay
- 0111 = 32 ns delay
- 1000 = 36 ns delay
- 1001 = 40 ns delay
- 1010 = 44 ns delay
- 1011 = 48 ns delay
- 1100 = 52 ns delay
- 1101 = 56 ns delay
- 1110 = 60 ns delay
- 1111 = 64 ns delay

## 6.10 Output Voltage Configuration

Two registers control the error amplifier reference voltage. The reference is coarsely set in 15 mV steps and then finely adjusted in 0.82 mV steps above the coarse setting (see [Registers 6-10](#) and [6-11](#)). Higher output voltages can be achieved by using a voltage divider connected between the output and the +V<sub>SEN</sub> pin. Care must be taken to ensure maximum voltage rating compliance on all pins.

**Note:** The OVFCO<sub>N</sub><VOUTEN> bit must be set to enable the output voltage setting registers.

### REGISTER 6-10: OVCCO<sub>N</sub>: OUTPUT VOLTAGE SET POINT COARSE CONTROL REGISTER

R/W-0	R/W-0	R/W-0	R/W-0	R/W-0	R/W-0	R/W-0	R/W-0
OVC7	OVC6	OVC5	OVC4	OVC3	OVC2	OVC1	OVC0
bit 7							bit 0

**Legend:**

R = Readable bit                      W = Writable bit                      U = Unimplemented bit, read as '0'  
 -n = Value at POR                      '1' = Bit is set                      '0' = Bit is cleared                      x = Bit is unknown

bit 7-0                      **OVC<7:0>**: Output Voltage Set Point Coarse Configuration bits  
 $OVC<7:0> = (V_{OUT}/15.8 \text{ mV}) + 15.8 \text{ mV}$

### REGISTER 6-11: OVFCO<sub>N</sub>: OUTPUT VOLTAGE SET POINT FINE CONTROL REGISTER

R/W-0	U-0	U-0	R/W-0	R/W-0	R/W-0	R/W-0	R/W-0
VOUTEN	—	—	OVF4	OVF3	OVF2	OVF1	OVF0
bit 7							bit 0

**Legend:**

R = Readable bit                      W = Writable bit                      U = Unimplemented bit, read as '0'  
 -n = Value at POR                      '1' = Bit is set                      '0' = Bit is cleared                      x = Bit is unknown

bit 7                      **VOUTEN**: Output Voltage DAC Enable bit  
 1 = Output Voltage DAC is enabled  
 0 = Output Voltage DAC is disabled

bit 6-5                      **Unimplemented**: Read as '0'

bit 4-0                      **OVF<4:0>**: Output Voltage Set Point Fine Configuration bits  
 $OVF<4:0> = (V_{OUT} - V_{OUT\_COARSE})/0.8 \text{ mV}$

# MCP19110/11

## 6.11 Output Undervoltage

The output voltage is monitored, and when it is below the output undervoltage threshold, the UVIF flag is set. This flag must be cleared in software. See [Section 15.3.1.4 “PIR2 Register”](#) for more information.

The output undervoltage threshold is controlled by the OUVCON register, as shown in [Register 6-12](#).

**REGISTER 6-12: OUVCON: OUTPUT UNDERVOLTAGE DETECT LEVEL CONTROL REGISTER**

R/W-x	R/W-x	R/W-x	R/W-x	R/W-x	R/W-x	R/W-x	R/W-x
OUV7	OUV6	OUV5	OUV4	OUV3	OUV2	OUV1	OUV0
bit 7							bit 0

**Legend:**

R = Readable bit                      W = Writable bit                      U = Unimplemented bit, read as '0'  
-n = Value at POR                      '1' = Bit is set                      '0' = Bit is cleared                      x = Bit is unknown

bit 7-0                      **OUV<7:0>**: Output Undervoltage Detect Level Configuration bits  
 $OUV<7:0> = (V_{OUT\_UV\_Detect\_Level})/15 \text{ mV}$

## 6.12 Output Overvoltage

The output voltage is monitored, and when it is above the output overvoltage threshold, the OVIF flag is set. This flag must be cleared in software. See [Section 15.3.1.4 “PIR2 Register”](#) for more information.

The output overvoltage threshold is controlled by the OOVCON register, as shown in [Register 6-13](#).

**REGISTER 6-13: OOVCON: OUTPUT OVERVOLTAGE DETECT LEVEL CONTROL REGISTER**

R/W-x	R/W-x	R/W-x	R/W-x	R/W-x	R/W-x	R/W-x	R/W-x
OOV7	OOV6	OOV5	OOV4	OOV3	OOV2	OOV1	OOV0
bit 7							bit 0

**Legend:**

R = Readable bit                      W = Writable bit                      U = Unimplemented bit, read as '0'  
-n = Value at POR                      '1' = Bit is set                      '0' = Bit is cleared                      x = Bit is unknown

bit 7-0                      **OOV<7:0>**: Output Overvoltage Detect Level Configuration bits  
 $OOV<7:0> = (V_{OUT\_OV\_Detect\_Level})/15 \text{ mV}$



## 6.13 Analog Peripheral Control

The MCP19110/11 has various analog peripherals. These peripherals can be configured to allow customizable operation. Refer to [Register 6-14](#) more information.

### 6.13.1 DIODE EMULATION MODE

The MCP19110/11 can operate in either diode emulation or synchronous rectification mode. When operating in diode emulation mode, the LDRV signal is terminated when the voltage across the low-side MOSFET is approximately 0V. This condition is true when the inductor current reaches approximately 0A. Both the HDRV and LDRV signals are low until the beginning of the next switching cycle. At that time, the HDRV signal is asserted high, turning on the high-side MOSFET.

When operating in Synchronous Rectification mode, the LDRV signal is held high until the beginning of the next switching cycle. At that time, the HDRV signal is asserted high, turning on the high-side MOSFET.

The PE1<DECON> bit controls the operating mode of the MCP19110/11.

### 6.13.2 HIGH-SIDE DRIVE STRENGTH

The peak source and sink current of the high-side driver can be configured to either be 1A source/sink or 2A source/sink. The PE1<DVRSTR> bit determines the high-side drive strength.

### 6.13.3 MOSFET DRIVER DEAD TIME

As described in [Section 6.9 “MOSFET Driver Programmable Dead Time”](#), the MOSFET drive dead time can be adjusted. In order to enable dead time settings, the proper bypass bits must be cleared. PE1<HDLYBY> and PE1<LDLYBY> control the delay circuits. Clearing the respective bits allows the dead time programmed by the DEADCON register to be added to the appropriate turn-on edge.

### 6.13.4 OUTPUT VOLTAGE SENSE PULL-UP/PULL-DOWN

A high-impedance pull-up on the +V<sub>SEN</sub> pin can be configured by setting the PE1<PUEN> bit. When set, the +V<sub>SEN</sub> pin is internally pulled-up to V<sub>DD</sub>.

A high-impedance pull-down on the -V<sub>SEN</sub> can be configured by setting the PE1<PDEN> bit. When set, the -V<sub>SEN</sub> pin is internally pulled-down to ground.

### 6.13.5 OUTPUT UNDERVOLTAGE ACCELERATOR

The MCP19110/11 has additional control circuitry to allow it to respond quickly to an output undervoltage condition. The enabling of this circuitry is handled by the PE1<UVTEE> bit. When this bit is set, the MCP19110/11 will respond to an output undervoltage condition by setting both the HDRV and LDRV signals low and turning off both the high-side and low-side MOSFETs.

### 6.13.6 OUTPUT OVERVOLTAGE ACCELERATOR

The MCP19110/11 has additional control circuitry to allow it to respond quickly to an output overvoltage condition. The enabling of this circuitry is handled by the PE1<OVTEE> bit. When this bit is set, the MCP19110/11 will respond to an output overvoltage condition by setting both the HDRV and LDRV signals low and turning off both the high-side and low-side MOSFETs.

# MCP19110/11

## REGISTER 6-14: PE1: ANALOG PERIPHERAL ENABLE 1 CONTROL REGISTER

R/W-0	R/W-0	R/W-0	R/W-0	R/W-0	R/W-0	R/W-0	R/W-0
DECON	DVRSTR	HDLYBY	LDLYBY	PDEN	PUEN	UVTEE	OVTEE
bit 7							bit 0

### Legend:

R = Readable bit

W = Writable bit

U = Unimplemented bit, read as '0'

-n = Value at POR

'1' = Bit is set

'0' = Bit is cleared

x = Bit is unknown

- bit 7      **DECON:** Diode Emulation Mode bit  
1 = Diode emulation mode enabled  
0 = Synchronous rectification mode enabled
- bit 6      **DVRSTR:** High-Side Drive Strength Configuration bit  
1 = High-side 1A source/sink drive strength  
0 = High-side 2A source/sink drive strength
- bit 5      **HDLYBY:** High-Side Dead Time Bypass bit  
1 = High-side dead time bypass is enabled  
0 = High-side dead time bypass is disabled
- bit 4      **LDLYBY:** Low-Side Dead Time Bypass bit  
1 = Low-side dead time bypass is enabled  
0 = Low-side dead time bypass is disabled
- bit 3      **PDEN:** -V<sub>SEN</sub> Weak Pull Down Enable bit  
1 = -V<sub>SEN</sub> weak pull down is enabled  
0 = -V<sub>SEN</sub> weak pull down is disabled
- bit 2      **PUEN:** +V<sub>SEN</sub> Weak Pull Up Enable bit  
1 = +V<sub>SEN</sub> weak pull up is enabled  
0 = +V<sub>SEN</sub> weak pull up is disabled
- bit 1      **UVTEE:** Output Undervoltage Accelerator Enable bit  
1 = Output undervoltage accelerator is enabled  
0 = Output undervoltage accelerator is disabled
- bit 0      **OVTEE:** Output Overvoltage Accelerator Enable bit  
1 = Output overvoltage accelerator is enabled  
0 = Output overvoltage accelerator is disabled

## 6.14 Analog Blocks Enable Control

Various analog circuit blocks can be enabled or disabled, as shown in [Register 6-15](#). Additional enable bits are located in the ATSTCON register.

### 6.14.1 OUTPUT OVERVOLTAGE ENABLE

The output overvoltage is enabled by setting the ABECON<OVDCEN> bit. Clearing this bit will disable the output overvoltage circuitry and cause the setting in the OOVCON register to be ignored.

### 6.14.2 OUTPUT UNDERVOLTAGE ENABLE

The output undervoltage is enabled by setting the ABECON<UVDCEN> bit. Clearing this bit will disable the output undervoltage circuitry and cause the setting in the OUVCON register to be ignored.

### 6.14.3 RELATIVE EFFICIENCY MEASUREMENT CONTROL

**Section 10.0 “Relative Efficiency Measurement”** describes the procedure used to measure the relative efficiency of the system. Setting the ABECON<MEASEN> bit initiates the relative measurement.

### 6.14.4 SLOPE COMPENSATION CONTROL

The slope compensation described in [Register 6-7](#) can be bypassed by setting the ABECON<SLCPBY> bit. Under normal operation, this bit will always be set.

### 6.14.5 CURRENT MEASUREMENT CONTROL

The peak current measurement circuitry is controlled by the ABECON<CRTMEN> bit. Setting this bit enables the current measurement circuitry. Under normal operation, this bit will be set.

### 6.14.6 INTERNAL TEMPERATURE MEASUREMENT CONTROL

The internal temperature of the silicon can be measured with the ADC. To enable the internal temperature measurement circuitry, the ABECON<TMPSEN> bit must be set.

### 6.14.7 RELATIVE EFFICIENCY CIRCUITRY CONTROL

**Section 10.0 “Relative Efficiency Measurement”** describes the procedure used to measure the relative efficiency of the system. Setting the ABECON<RECIREN> bit enables the relative efficiency measurement circuitry.

### 6.14.8 SIGNAL CHAIN CONTROL

Setting the ABECON<PATHEN> bit enables the voltage control path. Under normal operation, this bit is set.

# MCP19110/11

## REGISTER 6-15: ABECON: ANALOG BLOCK ENABLE CONTROL REGISTER

R/W-0	R/W-0	R/W-0	R/W-0	R/W-0	R/W-0	R/W-0	R/W-0
OVDCCEN	UVDCEN	MEASEN	SLCPBY	CRTMEN	TMPSEN	RECIREN	PATHEN
bit 7							bit 0

### Legend:

R = Readable bit

W = Writable bit

U = Unimplemented bit, read as '0'

-n = Value at POR

'1' = Bit is set

'0' = Bit is cleared

x = Bit is unknown

- bit 7      **OVDCCEN:** Output overvoltage DAC control bit  
1 = Output overvoltage DAC is enabled  
0 = Output overvoltage DAC is disabled
- bit 6      **UVDCEN:** Output undervoltage DAC control bit  
1 = Output undervoltage DAC is enabled  
0 = Output undervoltage DAC is disabled
- bit 5      **MEASEN:** Relative efficiency measurement control bit  
1 = Initiate relative efficiency measurement  
0 = Relative efficiency measurement not in progress
- bit 4      **SLCPBY:** Slope compensation bypass control bit  
1 = Slope compensation is disabled  
0 = Slope compensation is enabled
- bit 3      **CRTMEN:** Current measurement circuitry control bit  
1 = Current measurement circuitry is enabled  
0 = Current measurement circuitry is disabled
- bit 2      **TMPSEN:** Internal temperature sensor control bit  
1 = Internal temperature sensor circuitry is enabled  
0 = Internal temperature sensor circuitry is disabled
- bit 1      **RECIREN:** Relative efficiency circuitry control bit  
1 = Relative efficiency measurement circuitry is enabled  
0 = Relative efficiency measurement circuitry is disabled
- bit 0      **PATHEN:** Signal chain circuitry control bit  
1 = Signal chain circuitry is enabled  
0 = Signal chain circuitry is disabled

## 7.0 TYPICAL PERFORMANCE CURVES

**Note:** The graphs and tables provided following this note are a statistical summary based on a limited number of samples and are provided for informational purposes only. The performance characteristics listed herein are not tested or guaranteed. In some graphs or tables, the data presented may be outside the specified operating range (e.g., outside specified power supply range) and therefore, outside the warranted range.

**Note:** Unless otherwise indicated,  $V_{IN} = 12V$ ,  $F_{SW} = 300\text{ kHz}$ ,  $T_A = +25^\circ\text{C}$ .

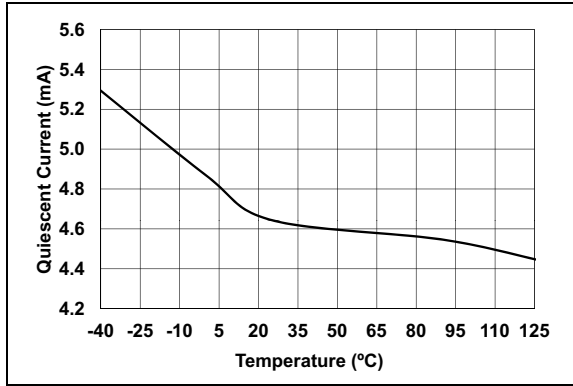

**FIGURE 7-1:**  $I_Q$  vs. Temperature.

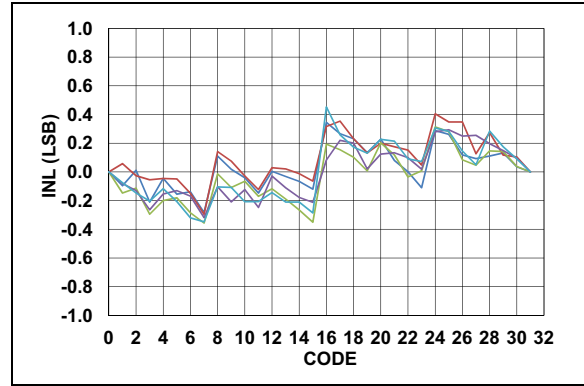

**FIGURE 7-4:** OVFCOIN DAC INL vs. Code and Temperature ( $-40^\circ\text{C}$  to  $+125^\circ\text{C}$ ).

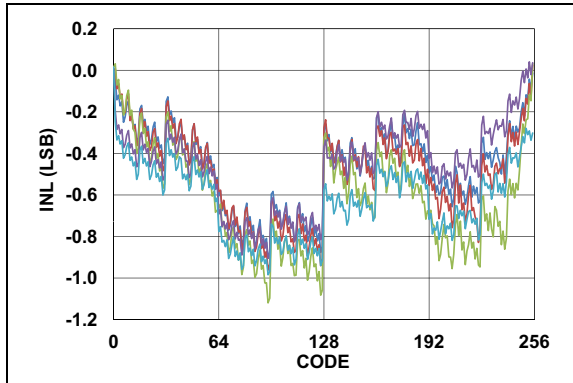

**FIGURE 7-2:** OVCCOIN DAC INL vs. Code and Temperature ( $-40^\circ\text{C}$  to  $+125^\circ\text{C}$ ).

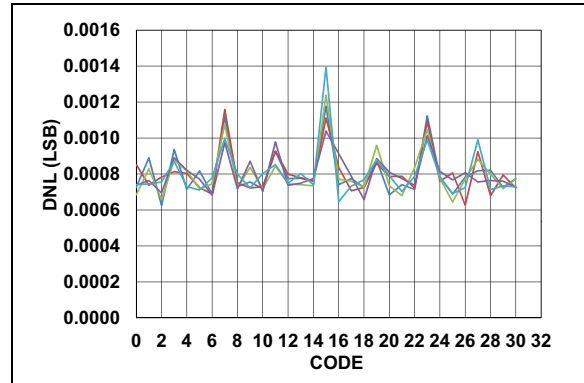

**FIGURE 7-5:** OVFCOIN DAC DNL vs. Code and Temperature ( $-40^\circ\text{C}$  to  $+125^\circ\text{C}$ ).

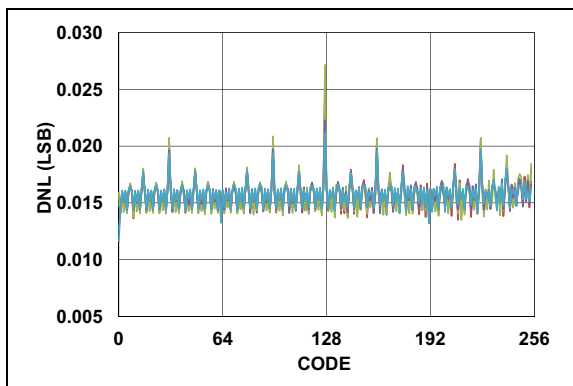

**FIGURE 7-3:** OVCCOIN DAC DNL vs. Code and Temperature ( $-40^\circ\text{C}$  to  $+125^\circ\text{C}$ ).

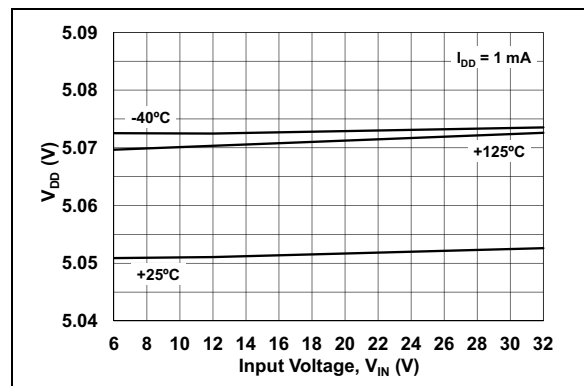

**FIGURE 7-6:**  $V_{DD}$  vs. Input Voltage.

# MCP19110/11

Note: Unless otherwise indicated,  $V_{IN} = 12V$ ,  $F_{SW} = 300\text{ kHz}$ ,  $T_A = +25^\circ\text{C}$ .

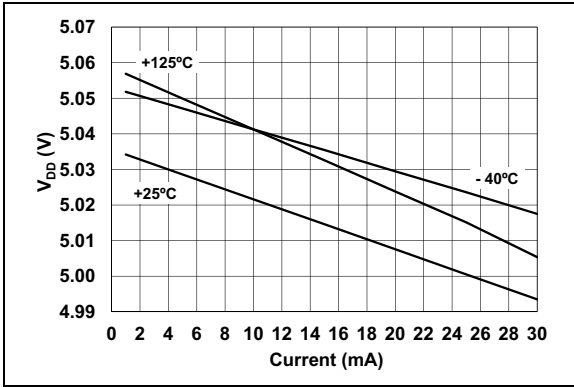

FIGURE 7-7:  $V_{DD}$  vs. Output Current.

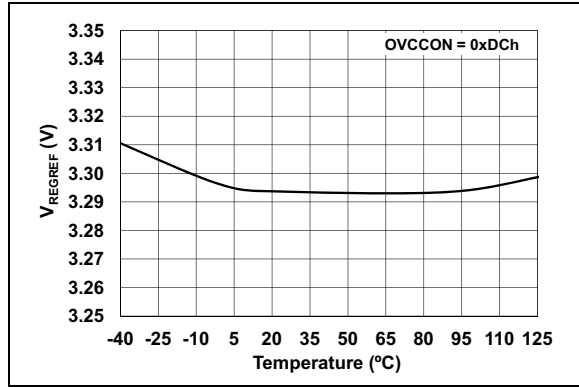

FIGURE 7-10:  $V_{REGREF}$  vs. Temperature ( $V_{REGREF} = 3.3V$ ).

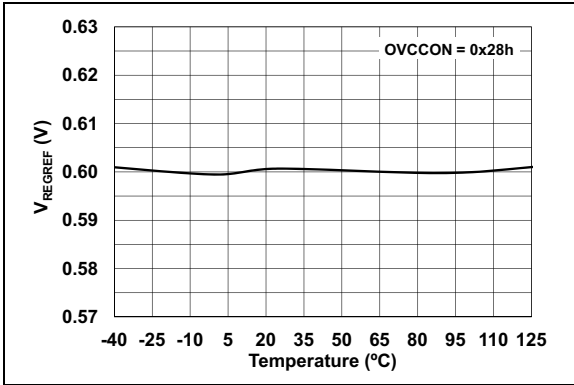

FIGURE 7-8:  $V_{REGREF}$  vs. Temperature ( $V_{REGREF} = 0.6V$ ).

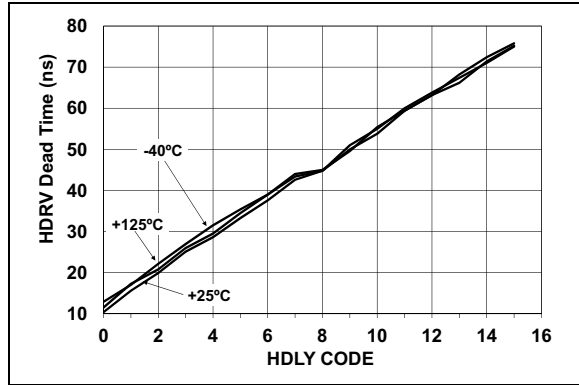

FIGURE 7-11: HDRV Dead Time vs. HDLY Code.

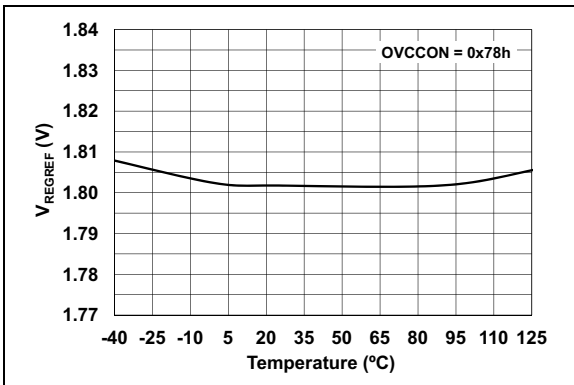

FIGURE 7-9:  $V_{REGREF}$  vs. Temperature ( $V_{REGREF} = 1.8V$ ).

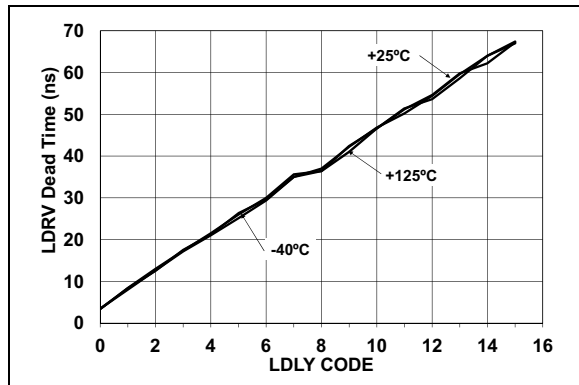
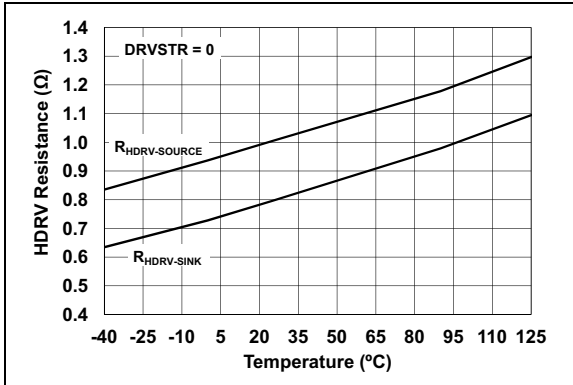
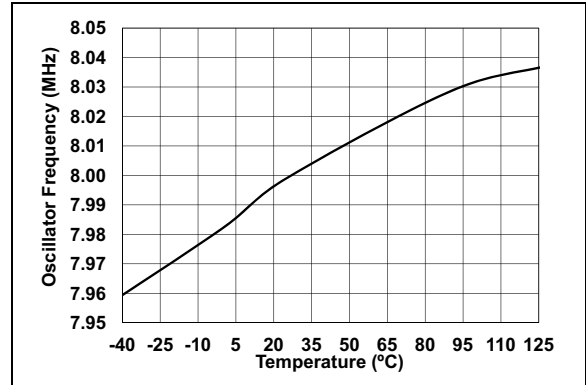

FIGURE 7-12: LDRV Dead Time vs. LDLY Code.

**Note:** Unless otherwise indicated,  $V_{IN} = 12V$ ,  $F_{SW} = 300\text{ kHz}$ ,  $T_A = +25^\circ\text{C}$ .



**FIGURE 7-13:** HDRV  $R_{DSon}$  vs. Temperature.



**FIGURE 7-16:** Oscillator Frequency vs. Temperature.

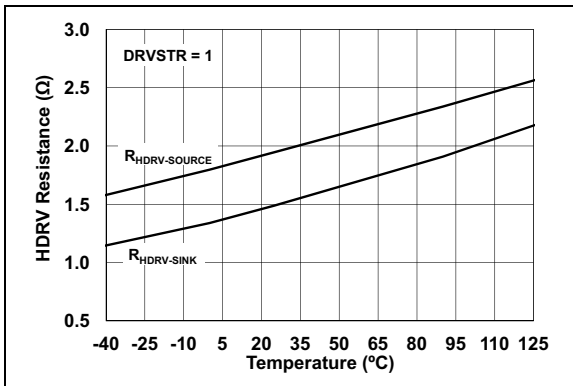

**FIGURE 7-14:** HDRV  $R_{DSon}$  vs. Temperature.

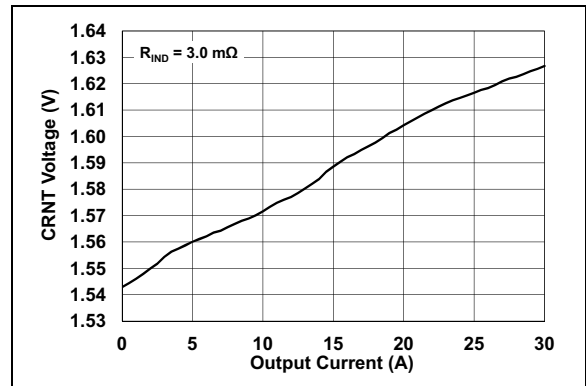

**FIGURE 7-17:** CRNT Voltage vs. Output Current.

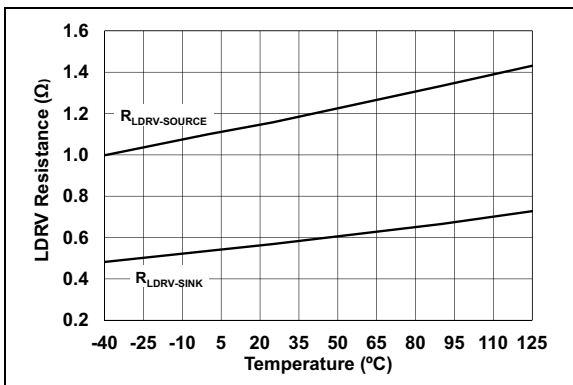

**FIGURE 7-15:** LDRV  $R_{DSon}$  vs. Temperature.

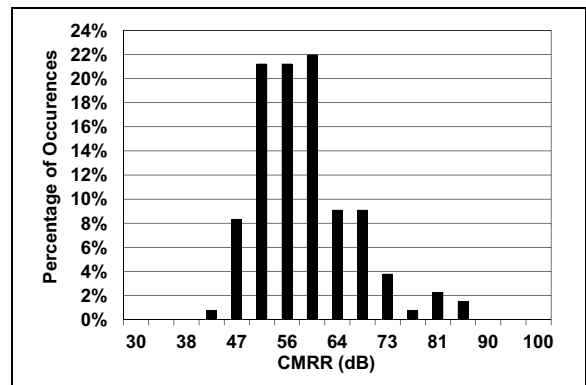

**FIGURE 7-18:** Remote Sense Amplifier CMRR.

# MCP19110/11

---

NOTES:



## 8.0 SYSTEM BENCH TESTING

To allow for easier system design and bench testing, the MCP19110/11 family of devices feature a multiplexer used to output various internal analog signals. These signals can be measured on the GPA0 pin through a unity gain buffer. The configuration control of the GPA0 pin is found in the ATSTCON register, as shown in [Register 8-1](#).

Control of the signals present at the output of the unity gain buffer is found in the BUFFCON register, as shown in [Register 8-2](#).

## 8.1 Analog Bench Test Control

### 8.1.1 ATSTCON REGISTER

The ATSTCON register contains the bits used to disable the MOSFET drivers and configure the GPA0 pin as the unity gain buffer out, as shown in [Register 8-1](#).

**Note 1:** The DRVDIS bit is reset to '1' so the high-side and low-side drivers are in a known state after reset. This bit must be cleared by software for normal operation.

### REGISTER 8-1: ATSTCON: ANALOG BENCH TEST CONTROL REGISTER

R/W-1	U-0	U-0	U-0	R/W-0	R/W-0	R/W-0	R/W-1
Reserved	—	—	Reserved	HIDIS	LODIS	BNCHEN	DRVDIS
bit 7							bit 0

#### Legend:

R = Readable bit	W = Writable bit	U = Unimplemented bit, read as '0'
-n = Value at POR	'1' = Bit is set	'0' = Bit is cleared
		x = Bit is unknown

bit 7	<b>Reserved</b>
bit 6-5	<b>Unimplemented:</b> Read as '0'
bit 4	<b>Reserved</b>
bit 3	<b>HIDIS:</b> High-side driver control bit 1 = High-side driver is disabled 0 = High-side driver is enabled
bit 2	<b>LODIS:</b> Low-side driver control bit 1 = Low-side driver is disabled 0 = Low-side driver is enabled
bit 1	<b>BNCHEN:</b> GPA0 bench test configuration control bit 1 = GPA0 is configured for analog bench test output 0 = GPA0 is configured for normal operation
bit 0	<b>DRVDIS:</b> MOSFET driver disable control bit 1 = High-side and low-side drivers are set low, PHASE pin is floating 0 = High-side and low-side drivers are set for normal operation

# MCP19110/11

## 8.2 Unity Gain Buffer

The unity gain buffer module is used during a multi-phase application and while operating in Bench Test mode.

When the ATSTCON<BNCHEN> bit is set, the device is in Bench Test mode and the ASEL<4:0> bits of the BUFFCON register determine which internal analog signal can be measured on the GPA0 pin.

When measuring signals with the unity gain buffer, the buffer offset must be added to the measured signal. The factory measured buffer offset can be read from memory location 2087h. Refer to [Section 11.1.1 “Reading Program Memory as Data”](#) for more information.

**REGISTER 8-2: BUFFCON: UNITY GAIN BUFFER CONTROL REGISTER**

R/W-0	R/W-0	R/W-0	R/W-0	R/W-0	R/W-0	R/W-0	R/W-0
MLTPH2	MLTPH1	MLTPH0	ASEL4	ASEL3	ASEL2	ASEL1	ASEL0
bit 7							bit 0

<b>Legend:</b>			
R = Readable bit	W = Writable bit	U = Unimplemented bit, read as '0'	
-n = Value at POR	'1' = Bit is set	'0' = Bit is cleared	x = Bit is unknown

- bit 7-5     **MLTPH<2:0>**: System configuration bits
  - 000 = Device set as stand-alone unit
  - 001 = Device set as multiple output MASTER
  - 010 = Device set as multiple output SLAVE
  - 011 = Device set as multi-phase MASTER
  - 100 = Device set as multi-phase SLAVE
  
- bit 4-0     **ASEL<4:0>**: Multiplexer output control bit
  - 00000 = Voltage proportional to current in the inductor
  - 00001 = Error amplifier output plus slope compensation, input to PWM comparator
  - 00010 = Input to slope compensation circuitry
  - 00011 = Band gap reference
  - 00100 = Output voltage reference
  - 00101 = Output voltage after internal differential amplifier
  - 00110 = Unimplemented
  - 00111 = Voltage proportional to the internal temperature
  - 01000 = Internal ground for current sense circuitry, see [Section 6.5 “Voltage for Zero Current”](#)
  - 01001 = Output overvoltage comparator reference
  - 01010 = Output undervoltage comparator reference
  - 01011 = Error amplifier output
  - 01100 = For a multi-phase SLAVE, error amplifier signal received from MASTER
  - 01101 = For multi-phase SLAVE, error signal received from MASTER with gain, see [Section 6.8 “MASTER Error Signal Gain”](#)
  - 01110 =  $V_N$  divided down by 1/5
  - 01111 = DC inductor valley current
  - 10000 = Unimplemented
  - 
  - 
  - 
  - 11100 = Unimplemented
  - 11101 = Overcurrent reference
  - 11110 = Unimplemented
  - 11111 = Unimplemented

## 9.0 DEVICE CALIBRATION

Read-only memory locations 2080h through 208Fh contain factory calibration data. Refer to [Section 18.0 “Flash Program Memory Control”](#) for information on how to read from these memory locations.

## 9.1 Calibration Word 1

The DOV<3:0> bits at memory location 2080h set the offset calibration for the output voltage remote sense differential amplifier. Firmware must read these values and write them to the DOVCAL register for proper calibration.

The FCAL<6:0> bits at memory location 2080h set the internal oscillator calibration. Firmware must read these values and write them to the OSCCAL register for proper calibration.

### REGISTER 9-1: CALWD1: CALIBRATION WORD 1 REGISTER

U-0	U-0	R/P-1	R/P-1	R/P-1	R/P-1
—	—	DOV3	DOV2	DOV1	DOV0
bit 13				bit 8	

U-0	R/P-1	R/P-1	R/P-1	R/P-1	R/P-1	R/P-1	R/P-1
—	FCAL6	FCAL5	FCAL4	FCAL3	FCAL2	FCAL1	FCAL0
bit 7							bit 0

#### Legend:

R = Readable bit	P = Programmable bit	U = Unimplemented bit, read as '0'
-n = Value at POR	'1' = Bit is set	'0' = Bit is cleared      x = Bit is unknown

- bit 13-12      **Unimplemented:** Read as '0'
- bit 11-8      **DOV<3:0>:** Output voltage remote sense differential amplifier offset calibration bits.
- bit 7          **Unimplemented:** Read as '0'
- bit 6-0      **FCAL<6:0>:** Internal oscillator calibration bits.

# MCP19110/11

## 9.2 Calibration Word 2

The TTA<3:0> bits at memory location 2082h calibrate the overtemperature shutdown threshold point. Firmware must read these values and write them to the TTACAL register for proper calibration.

The BGR<3:0> bits at memory location 2082h calibrate the internal band gap. Firmware must read these values and write them to the BGRCAL register for proper calibration.

### REGISTER 9-2: CALWD2: CALIBRATION WORD 2 REGISTER

U-0	U-0	R/P-1	R/P-1	R/P-1	R/P-1
—	—	TTA3	TTA2	TTA1	TTA0
bit 13					bit 8

U-0	U-0	U-0	U-0	R/P-1	R/P-1	R/P-1	R/P-1
—	—	—	—	BGR3	BGR2	BGR1	BGR0
bit 7							bit 0

#### Legend:

R = Readable bit

P = Programmable bit

U = Unimplemented bit, read as '0'

-n = Value at POR

'1' = Bit is set

'0' = Bit is cleared

x = Bit is unknown

bit 13-12 **Unimplemented:** Read as '0'

bit 11-8 **TTA<3:0>:** Overtemperature shutdown threshold calibration bits.

bit 7-4 **Unimplemented:** Read as '0'

bit 3-0 **BGR<3:0>:** Internal band gap calibration bits.

## 9.3 Calibration Word 3

The VRO<3:0> bits at memory location 2083h calibrate the offset of the buffer amplifier of the output voltage regulation reference set point. This effectively changes the band gap reference. Firmware must read these values and write them to the VROCAL register for proper calibration.

The ZRO<3:0> bits at memory location 2083h calibrate the offset of the error amplifier. Firmware must read these values and write them to the ZROCAL register for proper calibration.

### REGISTER 9-3: CALWD3: CALIBRATION WORD 3 REGISTER

U-0	U-0	R/P-1	R/P-1	R/P-1	R/P-1
—	—	VRO3	VRO2	VRO1	VRO0
bit 13		bit 8			

U-0	U-0	U-0	U-0	R/P-1	R/P-1	R/P-1	R/P-1
—	—	—	—	ZRO3	ZRO2	ZRO1	ZRO0
bit 7				bit 0			

#### Legend:

R = Readable bit  
-n = Value at POR

P = Programmable bit  
'1' = Bit is set

U = Unimplemented bit, read as '0'  
'0' = Bit is cleared  
x = Bit is unknown

- bit 13-12      **Unimplemented:** Read as '0'
- bit 11-8      **VRO<3:0>:** Reference voltage offset calibration bits.
- bit 7-4        **Unimplemented:** Read as '0'
- bit 3-0        **ZRO<3:0>:** Error amplifier offset voltage calibration bits.

# MCP19110/11

## 9.4 Calibration Word 4

The TANA<9:0> bits at memory location 2084h contain the ADC reading from the internal temperature sensor when the silicon temperature is at +30°C. The temperature coefficient of the internal temperature sensor is 16 mV/°C.

### REGISTER 9-4: CALWD4: CALIBRATION WORD 4 REGISTER

U-0	U-0	U-0	U-0	R/P-1	R/P-1
—	—	—	—	TANA9	TANA8
bit 13				bit 8	

R/P-1	R/P-1	R/P-1	R/P-1	R/P-1	R/P-1	R/P-1	R/P-1
TANA7	TANA6	TANA5	TANA4	TANA3	TANA2	TANA1	TANA0
bit 7							bit 0

#### Legend:

R = Readable bit

P = Programmable bit

U = Unimplemented bit, read as '0'

-n = Value at POR

'1' = Bit is set

'0' = Bit is cleared

x = Bit is unknown

bit 13-10 **Unimplemented:** Read as '0'

bit 9-0 **TANA<9:0>:** ADC internal temperature sensor at +30°C calibration bits

$TANA<9:0> = (\text{Temperature} \times 13.3 \text{ mV/}^\circ\text{C}) + 1.75$

## 9.5 Calibration Word 5

The DIFC<7:0> bits at memory location 2085h contain the offset voltage information for the output voltage difference amplifier. The value is an 8-bit two's complement number that represents the number of the OVCCON counts needed to adjust for the differential amplifier offset. This value can be used to completely remove the differential amplifier offset.

For example, the offset of the differential amplifier is measured to be -64 mV. Since one OVCCON count equals 16 mV, this represents four counts of the OVCCON register. Therefore, the value stored at location 2085h would be 0xFCh, where the setting of the DIFC7 bit represents a negative number.

### REGISTER 9-5: CALWD5: CALIBRATION WORD 5 REGISTER

U-0	U-0	U-0	U-0	U-0	U-0
—	—	—	—	—	—
bit 13					bit 8

R/P-1	R/P-1	R/P-1	R/P-1	R/P-1	R/P-1	R/P-1	R/P-1
DIFC7	DIFC6	DIFC5	DIFC4	DIFC3	DIFC2	DIFC1	DIFC0
bit 7							bit 0

#### Legend:

R = Readable bit  
-n = Value at POR

P = Programmable bit  
'1' = Bit is set

U = Unimplemented bit, read as '0'  
'0' = Bit is cleared  
x = Bit is unknown

bit 13-8      **Unimplemented:** Read as '0'

bit 7-0      **DIFC<7:0>:** OVCCON counts to adjust for differential amplifier offset calibration bits

# MCP19110/11

## 9.6 Calibration Word 6

The DIFF<7:0> bits at memory location 2086h contain the offset voltage information for the output voltage difference amplifier. The value is an 8-bit two's complement number that represents the number of the OVFCOIN counts needed to adjust for the differential amplifier offset. This value can be used to completely remove the differential amplifier offset.

For example, the offset of the differential amplifier is measured to be +4.2 mV. Since one OVFCOIN count equals 0.7 mV, this represents six counts of the OVFCOIN register. Therefore the value stored at location 2086h would be 0x06h, where clearing the DIFF7 bit represents a positive number.

### REGISTER 9-6: CALWD6: CALIBRATION WORD 6 REGISTER

U-0	U-0	U-0	U-0	U-0	U-0
—	—	—	—	—	—
bit 13					bit 8

R/P-1	R/P-1	R/P-1	R/P-1	R/P-1	R/P-1	R/P-1	R/P-1
DIFF7	DIFF6	DIFF5	DIFF4	DIFF3	DIFF2	DIFF1	DIFF0
bit 7							bit 0

#### Legend:

R = Readable bit

P = Programmable bit

U = Unimplemented bit, read as '0'

-n = Value at POR

'1' = Bit is set

'0' = Bit is cleared

x = Bit is unknown

bit 13-8      **Unimplemented:** Read as '0'

bit 7-0      **DIFF<7:0>:** OVFCOIN counts to adjust for differential amplifier offset calibration bits



## 9.7 Calibration Word 7

The BUFF<7:0> bits at memory location 2087h represent the offset voltage of the unity gain buffer. This is an 8-bit two's complement number. The MSB is the sign bit. If the MSB is set to 1, the resulting number is negative.

### REGISTER 9-7: CALWD7: CALIBRATION WORD 7 REGISTER

U-0	U-0	U-0	U-0	U-0	U-0
—	—	—	—	—	—
bit 13					bit 8

R/P-1	R/P-1	R/P-1	R/P-1	R/P-1	R/P-1	R/P-1	R/P-1
BUFF7	BUFF6	BUFF5	BUFF4	BUFF3	BUFF2	BUFF1	BUFF0
bit 7							bit 0

#### Legend:

R = Readable bit	P = Programmable bit	U = Unimplemented bit, read as '0'
-n = Value at POR	'1' = Bit is set	'0' = Bit is cleared
		x = Bit is unknown

bit 13-8      **Unimplemented:** Read as '0'

bit 7-0      **BUFF<7:0>:** Unity gain buffer offset voltage calibration bits

# MCP19110/11

---

NOTES:

## 10.0 RELATIVE EFFICIENCY MEASUREMENT

With a constant input voltage, output voltage and load current, any change in the high-side MOSFET on-time represents a change in the system efficiency. The MCP19110/11 is capable of measuring the on-time of the high-side MOSFET. Therefore, the relative efficiency of the system can be measured and optimized by changing the system parameters, such as switching frequency, driver dead time or high-side drive strength.

### 10.1 Relative Efficiency Measurement Procedure

To measure the relative efficiency, the RELEFF register, ABECON<MEASEN> and ABECON<RECIREN> bits, and the ADC RELEFF input are used. The following steps outlines the measurement process:

1. Set the ABECON<RECIREN> bit to enable the measurement circuitry.
2. Clear the ABECON<MEASEN> bit.
3. With the ADC, read the RELEFF channel and store this reading as the High.
4. With the ADC, read the VZC channel and store this reading as the Low.
5. Set the ABECON<MEASEN> bit to initiate a measurement cycle.
6. Monitor the RELEFF<MSDONE> bit. When set, it indicates the measurement is complete.

7. When the measurement is complete, use the ADC to read the RELEFF channel. This value becomes the Fractional variable in Equation 10-1. This reading should be accomplished approximately 50ms after the RELESS<MSDONE> bit is set.
8. Read the value of the RE<6:0> bits in the RELEFF register and store the reading as Whole.
9. Clear the ABECON<MEASEN> bit.
10. The relative efficiency is then calculated by the following equation:

#### EQUATION 10-1:

$$Unicycle = \frac{\left( Whole + \frac{(Fractional - Low)}{(High - Low)} \right)}{(PR2 + 1)}$$

Where:

Whole = Value obtained in Step 8 of the measurement procedure

Fractional = Value obtained in Step 7 of the measurement procedure

High = Value obtained in Step 3 of the measurement procedure

Low = Value obtained in Step 4 of the measurement procedure

**Note 1:** The RELEFF<MSDONE> bit is set and cleared automatically.

#### REGISTER 10-1: RELEFF: RELATIVE EFFICIENCY MEASUREMENT REGISTER

R/W-0	R/W-0	R/W-0	R/W-0	R/W-0	R/W-0	R/W-0	R/W-0
MSDONE	RE6	RE5	RE4	RE3	RE2	RE1	RE0
bit 7							bit 0

#### Legend:

R = Readable bit

W = Writable bit

U = Unimplemented bit, read as '0'

-n = Value at POR

'1' = Bit is set

'0' = Bit is cleared

x = Bit is unknown

bit 7 **MSDONE:** Relative efficiency measurement done bit

1 = Relative efficiency measurement is complete

0 = Relative efficiency measurement is not complete

bit 6-0 **RE<6:0>:** Whole clock counts for relative efficiency measurement result

# MCP19110/11

---

NOTES:

## 11.0 MEMORY ORGANIZATION

There are two types of memory in the MCP19110/11:

- Program Memory
  - Special Function Registers (SFRs)
  - General Purpose RAM

### 11.1 Program Memory Organization

The MCP19110/11 has a 13-bit program counter capable of addressing an 8K x 14 program memory space. Only the first 4K x 14 (0000h-0FFFh) is physically implemented. Addressing a location above this boundary will cause a wrap-around within the first 4K x 14 space. The Reset vector is at 0000h and the interrupt vector is at 0004h (see Figure 11-1). The width of the program memory bus (instruction word) is 14-bits. Since all instructions are a single word, the MCP19110/11 has space for 4K of instructions.

**FIGURE 11-1: PROGRAM MEMORY MAP AND STACK FOR MCP19110/11**

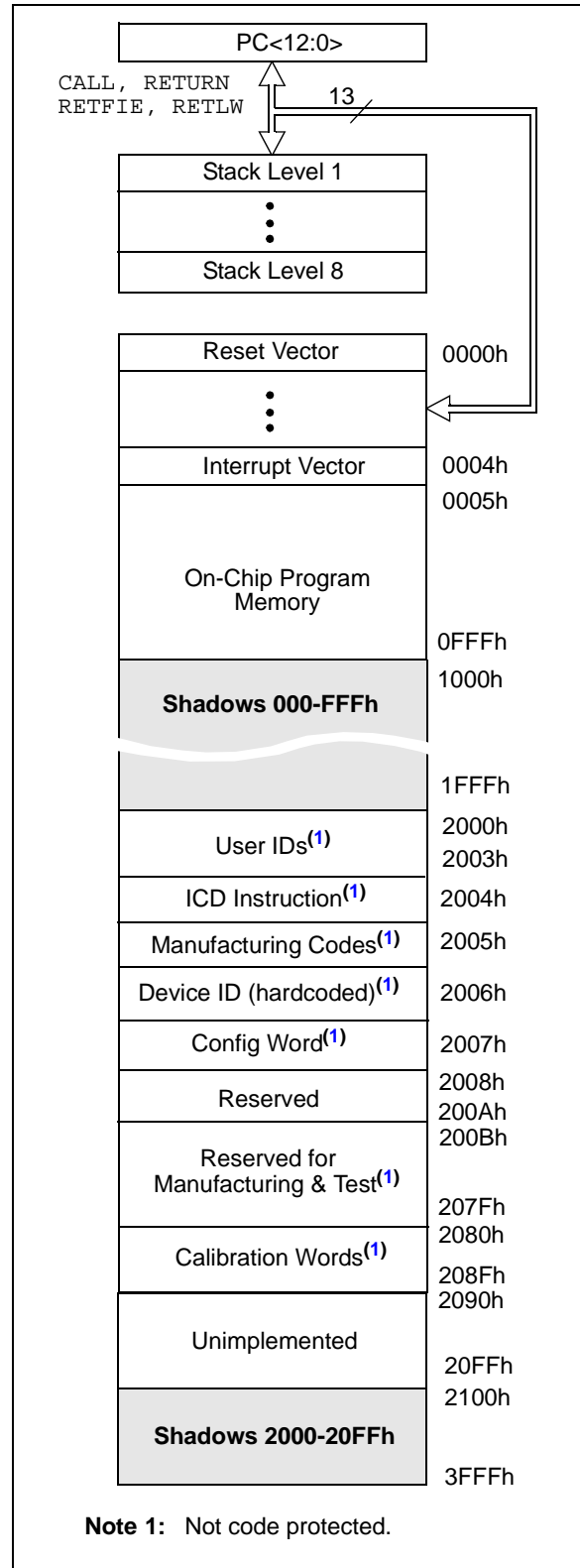

# MCP19110/11

## 11.1.1 READING PROGRAM MEMORY AS DATA

There are two methods of accessing constants in program memory. The first method is to use tables of RETLW instructions. The second method is to set a Files Select Register (FSR) to point to the program memory.

### 11.1.1.1 RETLW Instruction

The RETLW instruction can be used to provide access to tables of constants. The recommended way to create such a table is shown in [Example 11-1](#).

#### EXAMPLE 11-1: RETLW INSTRUCTION

```
constants
    RETLW DATA0      ;Index0 data
    RETLW DATA1      ;Index1 data
    RETLW DATA2
    RETLW DATA3

my_function
    ;... LOTS OF CODE...
    MOVLW    DATA_INDEX
    call constants
    ;... THE CONSTANT IS IN W
```

### 11.1.1.2 Indirect Read with Files Select Register (FSR)

The program memory can be accessed as data by setting bit 7 of the FSRxH register and reading the matching INDFx register. The MOVIW instruction will place the lower 8 bits of the addressed word in the W register. Writes to the program memory cannot be performed via the INDF registers. Instructions that access the program memory via the FSR require one extra instruction cycle to complete. [Example 11-2](#) demonstrates accessing the program memory via an FSR.

The HIGH directive will set bit<7> if a label points to a location in program memory.

#### EXAMPLE 11-2: ACCESSING PROGRAM MEMORY VIA FSR

```
constants
    RETLW DATA0      ;Index0 data
    RETLW DATA1      ;Index1 data
    RETLW DATA2
    RETLW DATA3

my_function
    ;... LOTS OF CODE...
    MOVLW    LOW constants
    MOVWF    FSR1L
    MOVLW    HIGH constants
    MOVWF    FSR1H
    MOVIW   0[FSR1]
    ;THE PROGRAM MEMORY IS IN W
```

## 11.2 Data Memory Organization

The data memory (see [Table 11-1](#)) is partitioned into four banks, which contain the General Purpose Registers (GPR) and the Special Function Registers (SFR). The Special Function Registers are located in the first 32 locations of each bank. Register locations 20h-7Fh in Bank 0, A0h-EFh in Bank 1 and 120h-16Fh in Bank 2 are General Purpose Registers, implemented as static RAM. All other RAM is unimplemented and returns '0' when read. The RP<1:0> bits of the STATUS register are the bank select bits.

RP1	RP0	
0	0	-> Bank 0 is selected
0	1	-> Bank 1 is selected
1	0	-> Bank 2 is selected
1	1	-> Bank 3 is selected

To move values from one register to another register, the value must pass through the W register. This means that for all register-to-register moves, two instruction cycles are required.

The STATUS register, shown in [Register 11-1](#), contains:

- the arithmetic status of the ALU
- the Reset status
- the bank select bits for data memory (RAM)

The STATUS register can be the destination for any instruction, like any other register. If the STATUS register is the destination for an instruction that affects the Z, DC or C bits, then the write to these three bits is disabled. These bits are set or cleared according to the device logic. Furthermore, the  $\overline{TO}$  and  $\overline{PD}$  bits are not writable. Therefore, the result of an instruction with the STATUS register as destination may be different than intended.

For example, CLRF STATUS will clear the upper three bits and set the Z bit. This leaves the STATUS register as '000u u1uu' (where u = unchanged).

Therefore, it is recommended that only BCF, BSF, SWAPF and MOVWF instructions are used to alter the STATUS register, because these instructions do not affect any Status bits. For other instructions not affecting any Status bits, see the [Section 29.0 "Instruction Set Summary"](#).

**Note 1:** The C and DC bits operate as Borrow and Digit Borrow out bits, respectively, in subtraction.

## REGISTER 11-1: STATUS: STATUS REGISTER

R/W-0	R/W-0	R/W-0	R-1	R-1	R/W-x	R/W-x	R/W-x
IRP	RP1	RP0	$\overline{TO}$	$\overline{PD}$	Z	DC <sup>(1)</sup>	C <sup>(1)</sup>
bit 7							bit 0

### Legend:

R = Readable bit	W = Writable bit	U = Unimplemented bit, read as '0'
-n = Value at POR	'1' = Bit is set	'0' = Bit is cleared
		x = Bit is unknown

bit 7	<b>IRP:</b> Register Bank Select bit (used for Indirect addressing) 1 = Bank 2 & 3 (100h – 1FFh) 0 = Bank 0 & 1 (00h – FFh)
bit 6-5	<b>RP&lt;1:0&gt;:</b> Register Bank Select bits (used for Direct addressing) 00 = Bank 0 (00h - 7Fh) 01 = Bank 1 (80h - FFh) 10 = Bank 2 (100h - 17Fh) 11 = Bank 3 (180h - 1FFh)
bit 4	<b><math>\overline{TO}</math>:</b> Time-out bit 1 = After power-up, CLRWD $\overline{T}$ instruction or SLEEP instruction 0 = A WDT time-out occurred
bit 3	<b><math>\overline{PD}</math>:</b> Power-down bit 1 = After power-up or by the CLRWD $\overline{T}$ instruction 0 = By execution of the SLEEP instruction
bit 2	<b>Z:</b> Zero bit 1 = The result of an arithmetic or logic operation is zero 0 = The result of an arithmetic or logic operation is not zero
bit 1	<b>DC:</b> Digit Carry/Digit Borrow bit <sup>(1)</sup> (ADDWF, ADDLW, SUBLW, SUBWF instructions) 1 = A carry-out from the 4 <sup>th</sup> low-order bit of the result occurred 0 = No carry-out from the 4 <sup>th</sup> low-order bit of the result
bit 0	<b>C:</b> Carry/Borrow bit <sup>(1)</sup> (ADDWF, ADDLW, SUBLW, SUBWF instructions) <sup>(1)</sup> 1 = A carry-out from the Most Significant bit of the result occurred 0 = No carry-out from the Most Significant bit of the result occurred

**Note 1:** For  $\overline{Borrow}$ , the polarity is reversed. A subtraction is executed by adding the two's complement of the second operand. For rotate (RRF, RLF) instructions, this bit is loaded with either the high-order or low-order bit of the source register.

### 11.2.1 SPECIAL FUNCTION REGISTERS

The Special Function Registers are registers used by the CPU and peripheral functions for controlling the desired operation of the device (see Table 11-1). These registers are static RAM.

The special registers can be classified into two sets: core and peripheral. The Special Function Registers associated with the microcontroller core are described in this section. Those related to the operation of the peripheral features are described in the associated section for that peripheral feature.

# MCP19110/11

## 11.3 DATA MEMORY

TABLE 11-1: MCP19110/11 DATA MEMORY MAP

File Address	File Address	File Address	File Address
Indirect addr. <sup>(1)</sup> 00h	Indirect addr. <sup>(1)</sup> 80h	Indirect addr. <sup>(1)</sup> 100h	Indirect addr. <sup>(1)</sup> 180h
TMR0 01h	OPTION_REG 81h	TMR0 101h	OPTION_REG 181h
PCL 02h	PCL 82h	PCL 102h	PCL 182h
STATUS 03h	STATUS 83h	STATUS 103h	STATUS 183h
FSR 04h	FSR 84h	FSR 104h	FSR 184h
PORTGPA 05h	TRISGPA 85h	WPUGPA 105h	IOCA 185h
PORTGPB 06h	TRISGPB 86h	WPUGPB 106h	IOCB 186h
PIR1 07h	PIE1 87h	PE1 107h	ANSELA 187h
PIR2 08h	PIE2 88h	BUFFCON 108h	ANSELB 188h
PCON 09h	APFCON 89h	ABECON 109h	
PCLATH 0Ah	PCLATH 8Ah	PCLATH 10Ah	PCLATH 18Ah
INTCON 0Bh	INTCON 8Bh	INTCON 10Bh	INTCON 18Bh
TMR1L 0Ch			PORTICD <sup>(2)</sup> 18Ch
TMR1H 0Dh			TRISICD <sup>(2)</sup> 18Dh
T1CON 0Eh			ICKBUG <sup>(2)</sup> 18Eh
TMR2 0Fh			BIGBUG <sup>(2)</sup> 18Fh
T2CON 10h	VINLVL 90h	SSPADD 110h	PMCON1 190h
PR2 11h	OCCON 91h	SSPBUF 111h	PMCON2 191h
		SSPCON1 112h	PMADRL 192h
PWMPHL 13h	CSGSCON 93h	SSPCON2 113h	PMADRH 193h
PWMPHH 14h		SSPCON3 114h	PMDATL 194h
PWMRL 15h	CSDGCON 95h	SSPMSK 115h	PMDATH 195h
PWMRH 16h		SSPSTAT 116h	
	VZCCON 97h	SSPADD2 117h	
	CMPZCON 98h	SSPMSK2 118h	OSCCAL 198h
OVCCON 19h	OUVCON 99h		DOVCAL 199h
OVFCON 1Ah	OOVCON 9Ah		TTACAL 19Ah
OSCTUNE 1Bh	DEADCON 9Bh		BGRCAL 19Bh
ADRESL 1Ch	SLPCRCON 9Ch		VROCAL 19Ch
ADRESH 1Dh	SLVGNCON 9Dh		ZROCAL 19Dh
ADCON0 1Eh	RELEFF 9Eh		
ADCON1 1Fh			ATSTCON 19Fh
General Purpose Register 96 Bytes	General Purpose Register 80 Bytes	General Purpose Register 80 bytes	
	Accesses Bank 0	Accesses Bank 0	Accesses Bank 0
20h	A0h	120h	1A0h
	EFh	16F	1EF
	F0h	170h	1F0h
7Fh	FFh	17Fh	1FFh

Bank 0

Bank 1

Bank2

Bank3

■ Unimplemented data memory locations, read as '0'.

- Note 1:** Not a physical register.  
**Note 2:** Only accessible when `DBGEN = 0` and `ICKBUG<INBUG> = 1`.



**TABLE 11-2: MCP19110/11 SPECIAL REGISTERS SUMMARY BANK 0**

Adr	Name	Bit 7	Bit 6	Bit 5	Bit 4	Bit 3	Bit 2	Bit 1	Bit 0	Value on POR Reset	Value on all other resets <sup>(1)</sup>
Bank 0											
00h	INDF	Addressing this location uses contents of FSR to address data memory (not a physical register)								xxxx xxxx	xxxx xxxx
01h	TMR0	Timer0 Module's Register								xxxx xxxx	uuuu uuuu
02h	PCL	Program Counter's (PC) Least Significant byte								0000 0000	0000 0000
03h	STATUS	IRP	RP1	RP0	$\overline{TO}$	$\overline{PD}$	Z	DC	C	0001 1xxx	000q quuu
04h	FSR	Indirect data memory address pointer								xxxx xxxx	uuuu uuuu
05h	PORTGPA	GPA7	GPA6	GPA5	GPA4	GPA3	GPA2	GPA1	GPA0	xxxx xxxx	uuuu uuuu
06h	PORTGPB	GPB7	GPB6	GPB5	GPB4	—	GPB2	GPB1	GPB0	xxx- xxxx	uuu- uuuu
07h	PIR1	—	ADIF	BCLIF	SSPIF	—	—	TMR2IF	TMR1IF	-000 --00	-000 --00
08h	PIR2	UVIF	—	OCIF	OVIF	—	—	VINIF	DCERIF	0-00 --00	0-00 --00
09h	PCON	—	—	—	—	—	$\overline{OT}$	$\overline{POR}$	—	---- -qq-	---- -uu-
0Ah	PCLATH	—	—	—	Write buffer for upper 5 bits of program counter					---0 0000	---0 0000
0Bh	INTCON	GIE	PEIE	TOIE	INTE	IOCE	TOIF	INTF	IOCF <sup>(3)</sup>	0000 000x	0000 000u
0Ch	TMR1L	Holding register for the Least Significant byte of the 16-bit TMR1								xxxx xxxx	uuuu uuuu
0Dh	TMR1H	Holding register for the Most Significant byte of the 16-bit TMR1								xxxx xxxx	uuuu uuuu
0Eh	T1CON	—	—	T1CKPS1	T1CKPS0	—	—	TMR1CS	TMR1ON	--00 --00	--uu --uu
0Fh	TMR2	Timer2 Module Register								0000 0000	uuuu uuuu
10h	T2CON	—	—	—	—	—	TMR2ON	T2CKPS1	T2CKPS0	---- -000	---- -000
11h	PR2	Timer2 Module Period Register								1111 1111	1111 1111
12h	—	Unimplemented								—	—
13h	PWMPHL	SLAVE Phase Shift Register								xxxx xxxx	uuuu uuuu
14h	PWMPHH	SLAVE Phase Shift Register								xxxx xxxx	uuuu uuuu
15h	PWMRL	PWM Register Low Byte								xxxx xxxx	uuuu uuuu
16h	PWMRH	PWM Register High Byte								xxxx xxxx	uuuu uuuu
17h	—	Unimplemented								—	—
18h	—	Unimplemented								—	—
19h	OVCCON	OVC7	OVC6	OVC5	OVC4	OVC3	OVC2	OVC1	OVC0	0000 0000	0000 0000
1Ah	OVFCON	VOUTON	—	—	OVF4	OVF3	OVF2	OVF1	OVF0	0--0 0000	0--0 0000
1Bh	OSCTUNE	—	—	—	TUN4	TUN3	TUN2	TUN1	TUN0	---0 0000	---0 0000
1Ch	ADRESL	Least significant 8 bits of the right-shifted result								xxxx xxxx	uuuu uuuu
1Dh	ADRESH	Most significant 2 bits of right-shifted result								---- --xx	uuuu uuuu
1Eh	ADCON0	—	CHS4	CHS3	CHS2	CHS1	CHS0	GO/DONE	ADON	-000 0000	-000 0000
1Fh	ADCON1	—	ADCS2	ADCS1	ADCS0	—	—	—	—	-000 ----	-000 ----

**Legend:** — = Unimplemented locations read as '0', u = unchanged, x = unknown, q = value depends on condition, shaded = unimplemented

**Note 1:** Other (non power-up) resets include MCLR Reset and Watchdog Timer Reset during normal operation.

**Note 2:** IRP & RP1 bits are reserved, always maintain these bits clear.

**Note 3:** MCLR and WDT reset does not affect the previous value data latch. The IOCF bit will be cleared upon reset but will set again if the mismatch exists.

# MCP19110/11

**TABLE 11-3: MCP19110/11 SPECIAL REGISTERS SUMMARY BANK 1**

Addr	Name	Bit 7	Bit 6	Bit 5	Bit 4	Bit 3	Bit 2	Bit 1	Bit 0	Value on POR Reset	Values on all other resets <sup>(1)</sup>
Bank 1											
80h	INDF	Addressing this location uses contents of FSR to address data memory (not a physical register)								xxxx xxxx	uuuu uuuu
81h	OPTION_REG	$\overline{\text{RAPU}}$	INTEDG	T0CS	T0SE	PSA	PS2	PS1	PS0	1111 1111	1111 1111
82h	PCL	Program Counter's (PC) Least Significant byte								0000 0000	0000 0000
83h	STATUS	IRP <sup>(2)</sup>	RP1 <sup>(2)</sup>	RP0	$\overline{\text{TO}}$	$\overline{\text{PD}}$	Z	DC	C	0001 1xxx	000q quuu
84h	FSR	Indirect data memory address pointer								xxxx xxxx	uuuu uuuu
85h	TRISGPA	TRISA7	TRISA6	TRISA5	TRISA4	TRISA3	TRISA2	TRISA1	TRISA0	1111 1111	1111 1111
86h	TRISGPB	TRISB7	TRISB6	TRISB5	TRISB4	—	TRISB2	TRISB1	TRISB0	1111 1111	1111 1111
87h	PIE1	—	ADIE	BCLIE	SSPIE	—	—	TMR2IE	TMR1IE	-000 --00	-000 --00
88h	PIE2	UVIE	—	OCIE	OVIE	—	—	VINIE	DCERIE	0-00 --00	0-00 --00
89h	APFCON	—	—	—	—	—	—	—	CLKSEL	---- --0	---- --0
8Ah	PCLATH	—	—	—	Write buffer for upper 5 bits of program counter					---0 0000	---0 0000
8Bh	INTCON	GIE	PEIE	T0IE	INTE	IOCE	TOIF	INTF	IOCF <sup>(4)</sup>	0000 000x	0000 000u
8Ch	—	Unimplemented								—	—
8Dh	—	Unimplemented								—	—
8Eh	—	Unimplemented								—	—
8Fh	—	Unimplemented								—	—
90h	VINLVL	UVLOEN	—	UVLO5	UVLO4	UVLO3	UVLO2	UVLO1	UVLO0	0-xx xxxx	0-uu uuuu
91h	OCCON	OCEN	OCLEB1	OCLEB0	OOC4	OOC3	OOC2	OOC1	OOC0	0xxx xxxx	0uuu uuuu
92h	—	—	—	Reserved	Reserved	Reserved	Reserved	Reserved	Reserved	--xx xxxx	--uu uuuu
93h	CSGSCON	—	Reserved	Reserved	Reserved	CSGS3	CSGS2	CSGS1	CSGS0	-xxx xxxx	-uuu uuuu
94h	—	Reserved	Reserved	Reserved	Reserved	Reserved	Reserved	Reserved	Reserved	xxxx xxxx	uuuu uuuu
95h	CSDGCON	CSDGEN	—	—	—	Reserved	CSDG2	CSDG1	CSDG0	0--- xxxx	0--- uuuu
96h	—	—	—	—	—	Reserved	Reserved	Reserved	Reserved	---- xxxx	---- uuuu
97h	VZCCON	VZC7	VZC6	VZC5	VZC4	VZC3	VZC2	VZC1	VZC0	xxxx xxxx	uuuu uuuu
98h	CMPZCON	CMPZF3	CMPZF2	CMPZF1	CMPZF0	CMPZG3	CMPZG2	CMPZG1	CMPZG0	xxxx xxxx	uuuu uuuu
99h	OUVCON	OUV7	OUV6	OUV5	OUV4	OUV3	OUV2	OUV1	OUV0	xxxx xxxx	uuuu uuuu
9Ah	OOVCON	OOV7	OOV6	OOV5	OOV4	OOV3	OOV2	OOV1	OOV0	xxxx xxxx	uuuu uuuu
9Bh	DEADCON	HDLY3	HDLY2	HDLY1	HDLY0	LDLY3	LDLY2	LDLY1	LDLY0	xxxx xxxx	uuuu uuuu
9Ch	SLPCRCON	SLPG3	SLPG2	SLPG1	SLPG0	SLPS3	SLPS2	SLPS1	SLPS0	xxxx xxxx	uuuu uuuu
9Dh	SLVGNCON	—	—	—	SLVGN4	SLVGN3	SLVGN2	SLVGN1	SLVGN0	---x xxxx	---u uuuu
9Eh	RELEFF	MSDONE	RE6	RE5	RE4	RE3	RE2	RE1	RE0	0000 0000	0000 0000
9Fh	—	Unimplemented								—	—

**Legend:** — = Unimplemented locations read as '0', u = unchanged, x = unknown, q = value depends on condition, shaded = unimplemented

- Note**
- Other (non power-up) resets include MCLR Reset and Watchdog Timer Reset during normal operation.
  - IRP & RP1 bits are reserved, always maintain these bits clear.
  - RA3 pull-up is enabled when pin is configured as MCLR in Configuration Word.
  - MCLR and WDT Reset does not affect the previous value data latch. The IOCF bit will be cleared upon reset but will set again if the mismatch exists.

**TABLE 11-4: MCP19110/11 SPECIAL REGISTERS SUMMARY BANK 2**

Adr	Name	Bit 7	Bit 6	Bit 5	Bit 4	Bit 3	Bit 2	Bit 1	Bit 0	Value on POR Reset	Value on all other resets <sup>(1)</sup>	
Bank 2												
100h	INDF	Addressing this location uses contents of FSR to address data memory (not a physical register)								xxxx xxxx	xxxx xxxx	
101h	TMR0	Timer0 Module's Register								xxxx xxxx	uuuu uuuu	
102h	PCL	Program Counter's (PC) Least Significant byte								0000 0000	0000 0000	
103h	STATUS	IRP <sup>(2)</sup>	RP1 <sup>(2)</sup>	RP0	$\overline{TO}$	$\overline{PD}$	Z	DC	C	0001 1xxx	000q quuu	
104h	FSR	Indirect data memory address pointer								xxxx xxxx	uuuu uuuu	
105h	WPUGPA	—	—	WPUA5	—	WPUA3	WPUA2	WPUA1	WPUA0	--1- 1111	--u- uuuu	
106h	WPUGPB	WPUB7	WPUB6	WPUB5	WPUB4	—	WPUB2	WPUB1	—	1111 -11-	uuuu -uu-	
107h	PE1	DECON	DVRSTR	HDLYBY	LDLYBY	PDEN	PUEN	UVTEE	OVTEE	0000 1100	0000 1100	
108h	BUFFCON	MLTPH2	MLTPH1	MLTPH0	ASEL4	ASEL3	ASEL2	ASEL1	ASEL0	0000 0000	0000 0000	
109h	ABECON	OVDCEEN	UVDCEN	MEASEN	SLCPBY	CRTMEN	TMPSEN	RECIREN	PATHEN	0000 0000	0000 0000	
10Ah	PCLATH	—	—	—	Write buffer for upper 5 bits of program counter				---	0000	---	0000
10Bh	INTCON	GIE	PEIE	TOIE	INTE	IOCE	TOIF	INTF	IOCF <sup>(3)</sup>	0000 000x	0000 000u	
10Ch	—	Unimplemented								—	—	
10Dh	—	Unimplemented								—	—	
10Eh	—	Unimplemented								—	—	
10Fh	—	Unimplemented								—	—	
110h	SSPADD	ADD<7:0>								0000 0000	0000 0000	
111h	SSPBUF	Synchronous Serial Port Receive Buffer/Transmit Register								xxxx xxxx	uuuu uuuu	
112h	SSPCON1	WCOL	SSPOV	SSPEN	CKP	SSPM>3:0>				0000 0000	0000 0000	
113h	SSPCON2	GCEN	ACKSTAT	ACKDT	ACKEN	RCEN	PEN	RSEN	SEN	0000 0000	0000 0000	
114h	SSPCON3	ACKTIM	PCIE	SCIE	BOEN	SDAHT	SBCDE	AHEN	DHEN	0000 0000	0000 0000	
115h	SSPMSK	MSK<7:0>								1111 1111	1111 1111	
116h	SSPSTAT	SMP	CKE	$\overline{D/A}$	P	S	$\overline{R/W}$	UA	BF	—	—	
117h	SSPADD2	ADD2<7:0>								0000 0000	0000 0000	
118h	SSPMSK2	MSK2<7:0>								1111 1111	1111 1111	
119h	—	Unimplemented								—	—	
11Ah	—	Unimplemented								—	—	
11Bh	—	Unimplemented								—	—	
11Ch	—	Unimplemented								—	—	
11Dh	—	Unimplemented								—	—	
11Eh	—	Unimplemented								—	—	
11Fh	—	Unimplemented								—	—	

**Legend:** — = Unimplemented locations read as '0', u = unchanged, x = unknown, q = value depends on condition, shaded = unimplemented

**Note 1:** Other (non power-up) resets include MCLR Reset and Watchdog Timer Reset during normal operation.

**Note 2:** IRP & RP1 bits are reserved, always maintain these bits clear.

**Note 3:** MCLR and WDT reset does not affect the previous value data latch. The IOCF bit will be cleared upon reset but will set again if the mismatch exists.

# MCP19110/11

**TABLE 11-5: MCP19110/11 SPECIAL REGISTERS SUMMARY BANK 3**

Addr	Name	Bit 7	Bit 6	Bit 5	Bit 4	Bit 3	Bit 2	Bit 1	Bit 0	Value on POR Reset	Values on all other resets <sup>(1)</sup>
Bank 3											
180h	INDF	Addressing this location uses contents of FSR to address data memory (not a physical register)								xxxx xxxx	uuuu uuuu
181h	OPTION_REG	RAPU	INTEDG	T0CS	T0SE	PSA	PS2	PS1	PS0	1111 1111	1111 1111
182h	PCL	Program Counter's (PC) Least Significant byte								0000 0000	0000 0000
183h	STATUS	IRP <sup>(2)</sup>	RP1 <sup>(2)</sup>	RP0	$\overline{TO}$	$\overline{PD}$	Z	DC	C	0001 1xxx	000q quuu
184h	FSR	Indirect data memory address pointer								xxxx xxxx	uuuu uuuu
185h	IOCA	IOCA7	IOCA6	IOCA5	IOCA4	IOCA3	IOCA2	IOCA1	IOCA0	0000 0000	0000 0000
186h	IOCB	IOCB7	IOCB6	IOCB5	IOCB4	—	IOCB2	IOCB1	IOCB0	0000 -000	0000 -000
187h	ANSELA	—	—	—	—	ANSA3	ANSA2	ANSA1	ANSA0	---- 1111	---- 1111
188h	ANSELB	—	—	ANSB5	ANSB4	—	ANSB2	ANSB1	—	--11 -11-	--11 -11-
189h	—	Unimplemented								—	—
18Ah	PCLATH	—	—	—	Write buffer for upper 5 bits of program counter					---0 0000	---0 0000
18Bh	INTCON	GIE	PEIE	TOIE	INTE	IOCE	TOIF	INTF	IOCF <sup>(4)</sup>	0000 000x	0000 000u
18Ch	PORTICD <sup>(5)</sup>	In-Circuit Debug Port Register									
18Dh	TRISICD <sup>(5)</sup>	In-Circuit Debug TRIS Register									
18Eh	ICKBUG <sup>(5)</sup>	In-Circuit Debug Register								0--- ----	0--- ----
18Fh	BIGBUG <sup>(5)</sup>	In-Circuit Debug Breakpoint Register								---- ----	---- ----
190h	PMCON1	—	CALSEL	—	—	—	WREN	WR	RD	-0-- -000	-0-- -000
191h	PMCON2	Program Memory Control Register 2 (not a physical register)								---- ----	---- ----
192h	PMADRL	PMADRL7	PMADRL6	PMADRL5	PMADRL4	PMADRL3	PMADRL2	PMADRL1	PMADRL0	0000 0000	0000 0000
193h	PMADRH	—	—	—	—	PMADRH3	PMADRH2	PMADRH1	PMADRH0	---- 0000	---- 0000
194h	PMDATL	PMDATL7	PMDATL6	PMDATL5	PMDATL4	PMDATL3	PMDATL2	PMDATL1	PMDATL0	0000 0000	0000 0000
195h	PMDATH	—	—	PMDATH5	PMDATH4	PMDATH3	PMDATH2	PMDATH1	PMDATH0	--00 0000	--00 0000
196h	—	Unimplemented								—	—
197h	—	Unimplemented								—	—
198h	OSCCAL	—	FCALT6	FCALT5	FCALT4	FCALT3	FCALT2	FCALT1	FCALT0	xxxx xxxx	uuuu uuuu
199h	DOVCAL	—	—	—	—	DOVT3	DOVT2	DOVT1	DOVT0	xxxx xxxx	uuuu uuuu
19Ah	TTACAL	—	—	—	—	TTA3	TTA2	TTA1	TTA0	xxxx xxxx	uuuu uuuu
19Bh	BGRCAL	Reserved	Reserved	Reserved	Reserved	BGRT3	BGRT2	BGRT1	BGRT0	xxxx xxxx	uuuu uuuu
19Ch	VROCAL	—	—	—	—	VROT3	VROT2	VROT1	VROT0	xxxx xxxx	uuuu uuuu
19Dh	ZROCAL	—	—	—	—	ZROT3	ZROT2	ZROT1	ZROT0	xxxx xxxx	uuuu uuuu
19Eh	—	Unimplemented								—	—
19Fh	ATSTCON	—	—	—	—	HIDIS	LODIS	BNCHEN	DRVDIS	1--0 0001	1--0 0001

**Legend:** — = Unimplemented locations read as '0', u = unchanged, x = unknown, q = value depends on condition, shaded = unimplemented

- Note**
- Other (non power-up) resets include MCLR Reset and Watchdog Timer Reset during normal operation.
  - IRP & RP1 bits are reserved, always maintain these bits clear.
  - RA3 pull-up is enabled when pin is configured as MCLR in Configuration Word.
  - MCLR and WDT Reset does not affect the previous value data latch. The IOCF bit will be cleared upon reset but will set again if the mismatch exists.
  - Only accessible when DBGEN = 0 and ICKBUG<INBUG> = 1.

## 11.3.0.1 OPTION Register

The OPTION register is a readable and writable register, which contains various control bits to configure:

- Timer0/WDT prescaler
- External GPA2/INT interrupt
- Timer0
- Weak pull-ups on PORTGPA and PORTGPB

**Note 1:** To achieve a 1:1 prescaler assignment for Timer0, assign the prescaler to the WDT by setting PSA bit to '1' of the OPTION register. See [Section 23.1.3 "Software Programmable Prescaler"](#)

### REGISTER 11-2: OPTION\_REG: OPTION REGISTER (Note 1)

R/W-1	R/W-1	R/W-1	R/W-1	R/W-1	R/W-1	R/W-1	R/W-1
RAPU	INTEDG	T0CS	T0SE	PSA	PS2	PS1	PS0
bit 7							bit 0

**Legend:**

R = Readable bit	W = Writable bit	U = Unimplemented bit, read as '0'
-n = Value at POR	'1' = Bit is set	'0' = Bit is cleared      x = Bit is unknown

- bit 7      **RAPU:** Port GPx Pull-up Enable bit  
1 = Port GPx pull-ups are disabled  
0 = Port GPx pull-ups are enabled
- bit 6      **INTEDG:** Interrupt Edge Select bit  
0 = Interrupt on rising edge of INT pin  
1 = Interrupt on falling edge of INT pin
- bit 5      **T0CE:** TMR0 Clock Source Select bit  
1 = Transition on T0CKI pin  
0 = Internal instruction cycle clock
- bit 4      **T0SE:** TMR0 Source Edge Select bit  
1 = Increment on high-to-low transition on T0CKI pin  
0 = Increment on low-to-high transition on T0CKI pin
- bit 3      **PSA:** Prescaler Assignment bit  
1 = Prescaler is assigned to WDT  
0 = Prescaler is assigned to the Timer0 module
- bit 2-0    **PS<2:0>:** Prescaler Rate Select bits

Bit Value	TMR0 Rate	WDT Rate
000	1: 2	1: 1
001	1: 4	1: 2
010	1: 8	1: 4
011	1: 16	1: 8
100	1: 32	1: 16
101	1: 64	1: 32
110	1: 128	1: 64
111	1: 256	1: 128

**Note 1:** Individual WPUx bit must also be enabled.

# MCP19110/11

## 11.4 PCL and PCLATH

The Program Counter (PC) is 13 bits wide. The low byte comes from the PCL register, which is a readable and writable register. The high byte (PC<12:8>) is not directly readable or writable and comes from PCLATH. On any Reset, the PC is cleared. Figure 11-2 shows the two situations for loading the PC. The upper example in Figure 11-2 shows how the PC is loaded on a write to PCL (PCLATH<4:0> → PCH). The lower example in Figure 11-2 shows how the PC is loaded during a CALL or GOTO instruction (PCLATH<4:3> → PCH).

**FIGURE 11-2: LOADING OF PC IN DIFFERENT SITUATIONS**

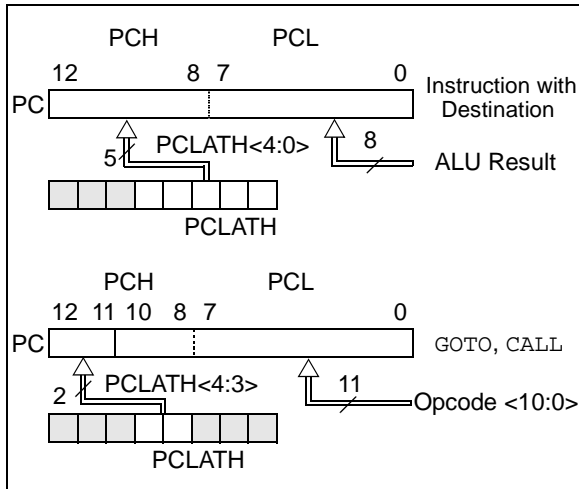

### 11.4.1 MODIFYING PCL

Executing any instruction with the PCL register as the destination simultaneously causes the Program Counter PC<12:8> bits (PCH) to be replaced by the contents of the PCLATH register. This allows the entire content of the program counter to be changed by writing the desired upper 5 bits to the PCLATH register. When the lower 8 bits are written to the PCL register, all 13 bits of the program counter will change to the values contained in the PCLATH register and those being written to the PCL register.

### 11.4.2 COMPUTED GOTO

A computed GOTO is accomplished by adding an offset to the program counter (ADDWF PCL). Care should be exercised when jumping into a look-up table or program branch table (computed GOTO) by modifying the PCL register. Assuming that PCLATH is set to the table start address, if the table length is greater than 255 instructions or if the lower 8 bits of the memory address rolls over from 0xFFh to 0X00h in the middle of the table, then PCLATH must be incremented for each address rollover that occurs between the table beginning and the table location within the table.

For more information, refer to Application Note AN556 – “Implementing a Table Read” (DS00556).

### 11.4.3 COMPUTED FUNCTION CALLS

A computed function CALL allows programs to maintain tables of functions and provides another way to execute state machines or look-up tables. When performing a table read using a computed function CALL, care should be exercised if the table location crosses a PCL memory boundary (each 256-byte block).

If using the CALL instruction, the PCH<2:0> and PCL registers are loaded with the operand of the CALL instruction. PCH<6:3> is loaded with PCLATH<6:3>.

### 11.4.4 STACK

The MCP19110/11 has an 8-level x 1-bit wide hardware stack (refer to Figure 11-1). The stack space is not part of either program or data space and the Stack Pointer is not readable or writable. The PC is PUSHed onto the stack when a CALL instruction is executed or an interrupt causes a branch. The stack is POPed in the event of a RETURN, RETLW or a RETFIE instruction execution. PCLATH is not affected by a PUSH or POP operation.

The stack operates as a circular buffer. This means that after the stack has been PUSHed eight times, the ninth push overwrites the value that was stored from the first push. The tenth push overwrites the second push (and so on).

- Note 1:** There are no Status bits to indicate Stack Overflow or Stack Underflow conditions.
- 2:** There are no instructions/mnemonics called PUSH or POP. These are actions that occur from the execution of the CALL, RETURN, RETLW and RETFIE instructions or the vectoring to an interrupt address.

## 11.5 Indirect Addressing, INDF and FSR Registers

The INDF register is not a physical register. Addressing the INDF register will cause indirect addressing.

Indirect addressing is possible by using the INDF register. Any instruction using the INDF register actually accesses data pointed to by the File Select Register (FSR). Reading INDF itself indirectly will produce 00h. Writing to the INDF register directly results in a no operation (although Status bits may be affected). An effective 9-bit address is obtained by concatenating the 8-bit FSR and the IRP bit of the STATUS register, as shown in Figure 11-3.

A simple program to clear RAM location 40h-7Fh using indirect addressing is shown in Example 11-3.

## EXAMPLE 11-3: INDIRECT ADDRESSING

```

MOVLW 0x40 ;initialize pointer
MOVWF FSR ;to RAM
NEXT   CLRF INDF ;clear INDF register
       INCF FSR ;inc pointer
       BTFSS FSR,7 ;all done?
       GOTO NEXT ;no clear next
CONTINUE ;yes continue
    
```

## FIGURE 11-3: DIRECT/INDIRECT ADDRESSING

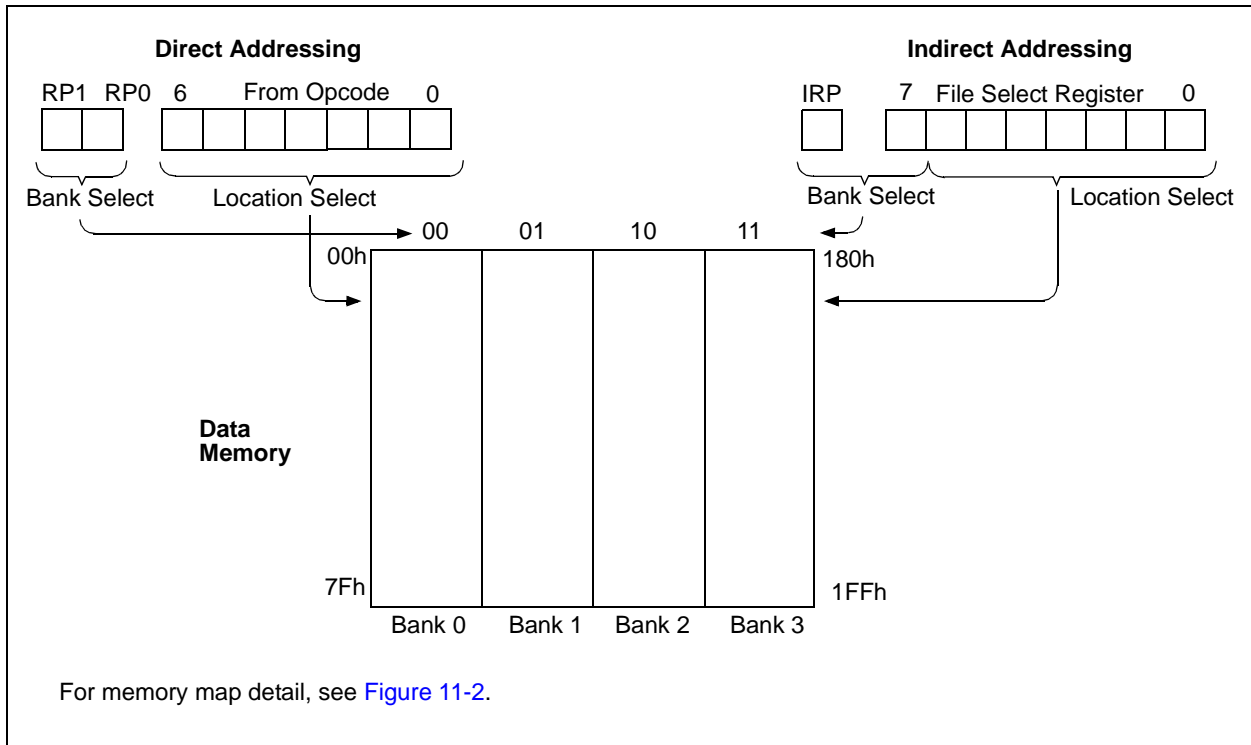

# MCP19110/11

---

NOTES:



## 12.0 DEVICE CONFIGURATION

Device Configuration consists of Configuration Word, Code Protection and Device ID.

**Note:** The  $\overline{\text{DBGEN}}$  bit in Configuration Word is managed automatically by device development tools, including debuggers and programmers. For normal device operation, this bit should be maintained as a '1'.

### 12.1 Configuration Word

There are several Configuration Word bits that allow different timers to be enabled and memory protection options. These are implemented as Configuration Word at 2007h.

**REGISTER 12-1: CONFIG – CONFIGURATION WORD REGISTER**

R/P-1	U-1	R/P-1	R/P-1	U-1	U-1
$\overline{\text{DBGEN}}$	—	WRT1	WRT0	—	—
bit 13			bit 8		

U-1	R/P-1	R/P-1	R/P-1	R/P-1	U-1	U-1	U-1
—	$\overline{\text{CP}}$	$\overline{\text{MCLRE}}$	$\overline{\text{PWRT\#}}$	WDTE	—	—	—
bit 7							bit 0

**Legend:**

R = Readable bit	P = Programmable bit	U = Unimplemented bit, read as '0'
-n = Value at POR	'1' = Bit is set	'0' = Bit is cleared
		x = Bit is unknown

- bit 13  **$\overline{\text{DBGEN}}$** : ICD Debug bit  
1 = ICD debug mode disabled  
0 = ICD debug mode enabled
- bit 12 **Unimplemented**: Read as '1'
- bit 11-10 **WRT<1:0>**: Flash Program Memory Self Write Enable bit  
11 = Write protection off  
10 = 000h to 3FFh write protected, 400h to FFFh may be modified by PMCON1 control  
01 = 000h to 7FFh write protected, 800h to FFFh may be modified by PMCON1 control  
00 = 000h to FFFh write protected, entire program memory is write protected.
- bit 9-7 **Unimplemented**: Read as '1'
- bit 6  **$\overline{\text{CP}}$** : Code Protection  
1 = Program memory code protection is disabled  
0 = Program memory code protection is enabled
- bit 5  **$\overline{\text{MCLRE}}$** :  $\overline{\text{MCLRE}}$  Pin Function Select  
1 =  $\overline{\text{MCLRE}}$  pin is  $\overline{\text{MCLRE}}$  function and weak internal pull-up is enabled  
0 =  $\overline{\text{MCLRE}}$  pin is alternate function,  $\overline{\text{MCLRE}}$  function is internally disabled
- bit 4  **$\overline{\text{PWRT\#}}$** : Power-up Timer Enable bit  
1 = PWRT disabled  
0 = PWRT enabled
- bit 3 **WDTE**: Watchdog Timer Enable bit  
1 = WDT enabled  
0 = WDT disabled
- bit 2-0 **Unimplemented**: Read as '1'

# MCP19110/11

## 12.2 Code Protection

Code protection allows the device to be protected from unauthorized access. Internal access to the program memory is unaffected by any code protection setting.

### 12.2.1 PROGRAM MEMORY PROTECTION

The entire program memory space is protected from external reads and writes by the  $\overline{CP}$  bit in the Configuration Word. When  $\overline{CP} = 0$ , external reads and writes of the program memory are inhibited and a read will return all '0's. The CPU can continue to read program memory, regardless of the protection bit settings. Writing the program memory is dependent upon the write protection setting. See [Section 12.3 "Write Protection"](#) for more information.

## 12.3 Write Protection

Write protection allows the device to be protected from unintended self-writes. Applications, such as bootloader software, can be protected while allowing other regions of the program memory to be modified.

The WRT<1:0> bits in the Configuration Word define the size of the program memory block that is protected.

### REGISTER 12-2: DEVIDEID: DEVICE ID REGISTER<sup>(1)</sup>

R	R	R	R	R	R
DEV<8:3>					
bit 13			bit 8		

R	R	R	R	R	R	R	R
DEV<2:0>			REV<4:0>				
bit 7			bit 0				

<b>Legend:</b>			
R = Readable bit	P = Programmable bit	U = Unimplemented bit, read as '0'	
-n = Value at POR	'1' = Bit is set	'0' = Bit is cleared	x = Bit is unknown

bit 13-5      **DEV<8:0>**: Device ID bits

Device	DEVICEID<13:0> Values	
	DEV<8:0>	REV<4:0>
MCP19110	00 0111 111	x xx
MCP19111	10 1111 100	x xxxxx

bit 4-0      **REV<4:0>**: Revision ID bits  
 These bits are used to identify the revision.

**Note 1:** This location cannot be written.

## 12.4 ID Locations

Four memory locations (2000h – 2003h) are designated as ID locations where the user can store checksum or other code identification numbers. These locations are not accessible during normal execution but are readable and writable during Program/Verify mode. Only the Least Significant seven bits of the ID locations are reported when using MPLAB Integrated Development Environment (IDE).

## 12.5 Device ID and Revision ID

The memory location 2006h is where the Device ID and Revision ID are stored. The upper nine bits hold the Device ID. The lower five bits hold the Revision ID.

Development tools, such as device programmers and debuggers, may be used to read the Device ID and Revision ID.

## 13.0 OSCILLATOR MODES

The MCP19110/11 has one oscillator configuration which is an 8 MHz internal oscillator.

### 13.1 Internal Oscillator (INTOSC)

The Internal Oscillator module provides a system clock source of 8 MHz. The frequency of the internal oscillator can be trimmed with a calibration value in the OSCTUNE register.

### 13.2 Oscillator Calibration

The 8 MHz internal oscillator is factory calibrated. The factory calibration values reside in the read-only Calibration Word 1 register. These values must be read from the Calibration Word 1 register and stored in the OSCCAL register. Refer to [Section 18.0 “Flash Program Memory Control”](#) for the procedure on reading from program memory.

**Note 1:** The FCAL<6:0> bits from the Calibration Word 1 register must be written into the OSCCAL register to calibrate the internal oscillator.

### 13.3 Frequency Tuning in User Mode

In addition to the factory calibration, the base frequency can be tuned in the user's application. This frequency tuning capability allows the user to deviate from the factory-calibrated frequency. The user can tune the frequency by writing to the OSCTUNE register (see [Register 13-1](#)).

**REGISTER 13-1: OSCTUNE – OSCILLATOR TUNING REGISTER**

U-0	U-0	U-0	R/W-0	R/W-0	R/W-0	R/W-0	R/W-0
—	—	—	TUN4	TUN3	TUN2	TUN1	TUN0
bit 7							bit 0

**Legend:**

R = Readable bit	W = Writable bit	U = Unimplemented bit, read as '0'
-n = Value at POR	'1' = Bit is set	'0' = Bit is cleared      x = Bit is unknown

bit 7-5      **Unimplemented:** Read as '0'

bit 4-0      **TUN<4:0>:** Frequency Tuning bits

01111 = Maximum frequency

01110 =

•

•

•

00001 =

00000 = Center frequency. Oscillator Module is running at the calibrated frequency.

11111 =

•

•

•

10000 = Minimum frequency

# MCP19110/11

## 13.3.1 OSCILLATOR DELAY UPON POWER-UP, WAKE-UP AND BASE FREQUENCY CHANGE

In applications where the OSCTUNE register is used to shift the frequency of the internal oscillator, the application should not expect the frequency of the internal oscillator to stabilize immediately. In this case, the frequency may shift gradually toward the new value. The time for this frequency shift is less than eight cycles of the base frequency.

On power up, the device is held in reset by the power-up time, if the power-up timer is enabled.

Following a wake-up from Sleep mode or POR, an internal delay of ~10  $\mu$ s is invoked to allow the memory bias to stabilize before program execution can begin.

**TABLE 13-1: SUMMARY OF REGISTERS ASSOCIATED WITH CLOCK SOURCES**

Name	Bit 7	Bit 6	Bit 5	Bit 4	Bit 3	Bit 2	Bit 1	Bit 0	Register on Page
OSCTUNE	—	—	—	TUN4	TUN3	TUN2	TUN1	TUN0	83

**Legend:** — = unimplemented locations read as '0'. Shaded cells are not used by clock sources.

**TABLE 13-2: SUMMARY OF CALIBRATION WORD ASSOCIATED WITH CLOCK SOURCES**

Name	Bits	Bit -/7	Bit -/6	Bit 13/5	Bit 12/4	Bit 11/3	Bit 10/2	Bit 9/1	Bit 8/0	Register on Page
CALWD1	13:8	—	—	—	—	DOV3	DOV2	DOV1	DOV0	59
	7:0	—	FCAL6	FCAL5	FCAL4	FCAL3	FCAL2	FCAL1	FCAL0	

**Legend:** — = unimplemented locations read as '0'. Shaded cells are not used by clock sources.

## 14.0 RESETS

The reset logic is used to place the MCP19110/11 into a known state. The source of the reset can be determined by using the device status bits.

There are multiple ways to reset this device:

- Power-on Reset (POR)
- Overtemperature Reset (OT)
- MCLR Reset
- WDT Reset

To allow  $V_{DD}$  to stabilize, an optional power-up timer can be enabled to extend the Reset time after a POR event.

Some registers are not affected in any Reset condition; their status is unknown on POR and unchanged in any other Reset. Most other registers are reset to a “Reset state” on:

- Power-on Reset
- MCLR Reset
- MCLR Reset during Sleep
- WDT Reset

WDT wake-up does not cause register resets in the same manner as a WDT Reset, since wake-up is viewed as the resumption of normal operation.  $\overline{TO}$  and  $\overline{PD}$  bits are set or cleared differently in different Reset situations, as indicated in Table 14-1. Software can use these bits to determine the nature of the Reset. See Table 14-2 for a full description of Reset states of all registers.

A simplified block diagram of the On-Chip Reset Circuit is shown in Figure 14-1.

The  $\overline{MCLR}$  Reset path has a noise filter to detect and ignore small pulses. See Section 5.0 “Digital Electrical Characteristics” for pulse-width specifications.

**FIGURE 14-1: SIMPLIFIED BLOCK DIAGRAM OF ON-CHIP RESET CIRCUIT**

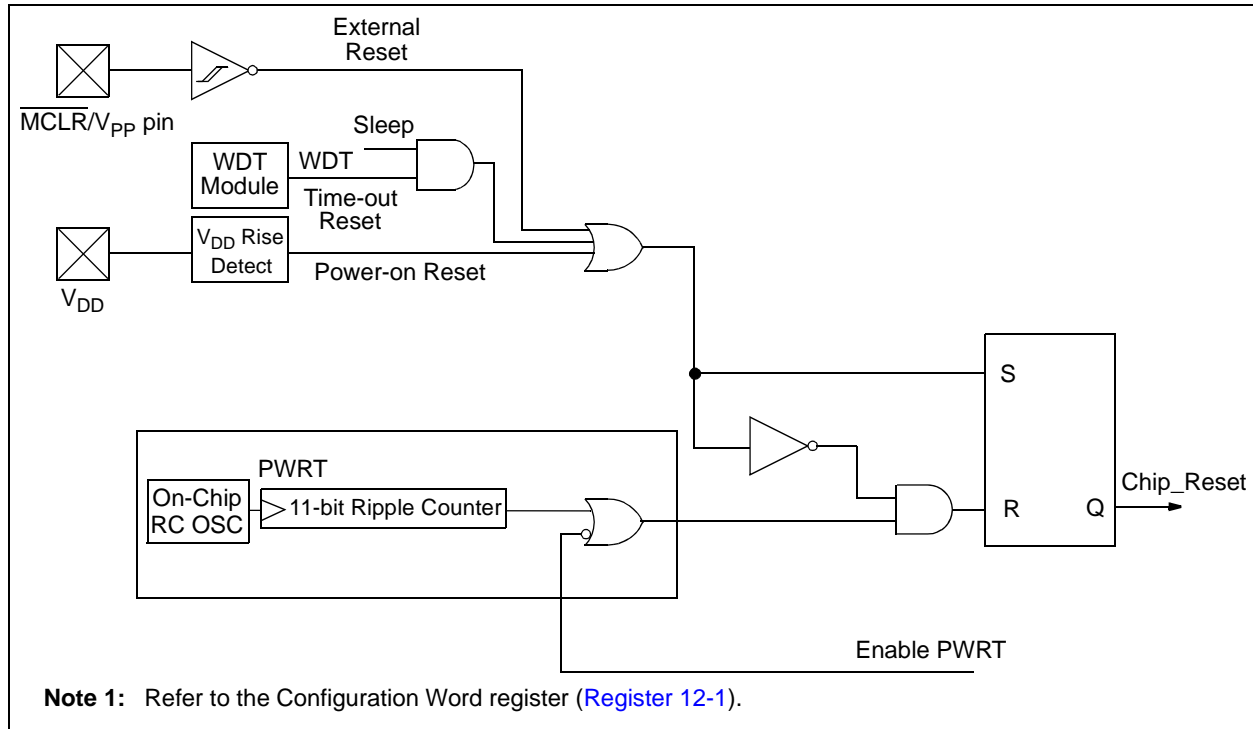

**TABLE 14-1: TIME-OUT IN VARIOUS SITUATIONS**

Power-up		Wake-up from Sleep
$\overline{PWRTE} = 0$	$\overline{PWRTE} = 1$	
$T_{PWRT}$	—	—

# MCP19110/11

**TABLE 14-2: STATUS/PCON BITS AND THEIR SIGNIFICANCE**

$\overline{\text{POR}}$	$\overline{\text{TO}}$	$\overline{\text{PD}}$	Condition
0	1	1	Power-on Reset
u	0	u	WDT Reset
u	0	0	WDT Wake-up
u	u	u	$\overline{\text{MCLR}}$ Reset during normal operation
u	1	0	$\overline{\text{MCLR}}$ Reset during Sleep

**Legend:** u = unchanged, x = unknown

## 14.1 Power-on Reset (POR)

The on-chip POR circuit holds the chip in Reset until  $V_{DD}$  has reached a high enough level for proper operation. To take advantage of the POR, simply connect the  $\overline{\text{MCLR}}$  pin through a resistor to  $V_{DD}$ . This will eliminate external RC components usually needed to create Power-on Reset.

**Note:** The POR circuit does not produce an internal Reset when  $V_{DD}$  declines. To re-enable the POR,  $V_{DD}$  must reach  $V_{SS}$  for a minimum of 100  $\mu\text{s}$ .

When the device starts normal operation (exits the Reset condition), device operating parameters (i.e., voltage, frequency, temperature, etc.) must be met to ensure proper operation. If these conditions are not met, the device must be held in Reset until the operating conditions are met.

## 14.2 $\overline{\text{MCLR}}$

MCP19110/11 has a noise filter in the  $\overline{\text{MCLR}}$  Reset path. The filter will detect and ignore small pulses.

It should be noted that a WDT Reset does not drive  $\overline{\text{MCLR}}$  pin low.

Voltages applied to the  $\overline{\text{MCLR}}$  pin that exceed its specification can result in both  $\overline{\text{MCLR}}$  Resets and excessive current beyond the device specification during the ESD event. For this reason, Microchip recommends that the  $\overline{\text{MCLR}}$  pin no longer be tied directly to  $V_{DD}$ . The use of an RC network, as shown in Figure 14-2, is suggested.

An internal  $\overline{\text{MCLR}}$  option is enabled by clearing the MCLRE bit in the Configuration Word register. When  $\text{MCLRE} = 0$ , the Reset signal to the chip is generated internally. When the  $\text{MCLRE} = 1$ , the  $\overline{\text{MCLR}}$  pin becomes an external Reset input. In this mode, the  $\overline{\text{MCLR}}$  pin has a weak pull-up to  $V_{DD}$ .

**FIGURE 14-2: RECOMMENDED  $\overline{\text{MCLR}}$  CIRCUIT**

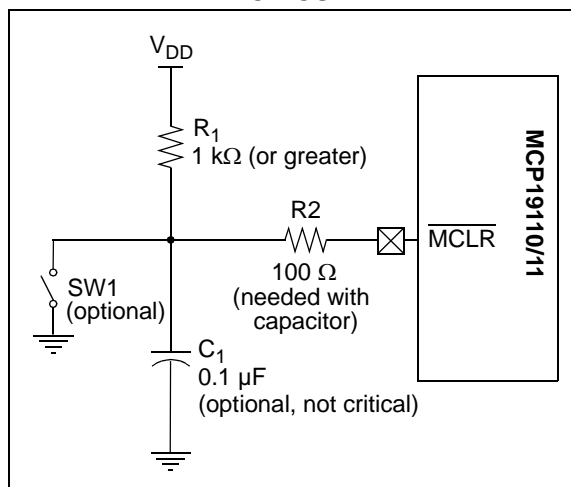

## 14.3 Power-up Timer (PWRT)

The Power-up Timer provides a fixed 64 ms (nominal) time-out on power-up only, from POR Reset. The Power-up Timer operates from an internal RC oscillator. The chip is kept in Reset as long as PWRT is active. The PWRT delay allows the  $V_{DD}$  to rise to an acceptable level. A Configuration bit ( $\overline{PWRT}$ ), can disable (if set) or enable (if cleared or programmed) the Power-up Timer.

The Power-up Timer delay will vary from chip-to-chip due to:

- $V_{DD}$  variation
- Temperature variation
- Process variation

**Note:** Voltage spikes below  $V_{SS}$  at the  $\overline{MCLR}$  pin, inducing currents greater than 80 mA, may cause latch-up. Thus, a series resistor of 50-100 $\Omega$  should be used when applying a “low” level to the  $\overline{MCLR}$  pin, rather than pulling this pin directly to  $V_{SS}$ .

## 14.4 Watchdog Timer (WDT) Reset

The Watchdog Timer generates a Reset if the firmware does not issue a  $\overline{CLRWD}$  instruction within the time-out period. The  $\overline{TO}$  and  $\overline{PD}$  bits in the STATUS register are changed to indicate the WDT Reset. See [Section 17.0 “Watchdog Timer \(WDT\)”](#) for more information.

## 14.5 Power-Up Timer

The Power-up Timer optionally delays device execution after a POR event. This timer is typically used to allow  $V_{DD}$  to stabilize before allowing the device to start running.

The Power-up Timer is controlled by the  $\overline{PWRT}$  bit of Configuration Word.

## 14.6 Start-up Sequence

Upon the release of a POR, the following must occur before the device will begin executing:

- Power-up Timer runs to completion (if enabled)
- Oscillator start-up timer runs to completion
- $\overline{MCLR}$  must be released (if enabled)

The total time-out will vary based on  $\overline{PWRT}$  bit status. For example, with  $\overline{PWRT}$  bit erased (PWRT disabled), there will be no time-out at all. [Figures 14-3, 14-4 and 14-5](#) depict time-out sequences.

Since the time-outs occur from the POR pulse, if  $\overline{MCLR}$  is kept low long enough, the time-outs will expire. Then, bringing  $\overline{MCLR}$  high will begin execution immediately (see [Figure 14-4](#)). This is useful for testing purposes or to synchronize more than one MCP19110/11 device operating in parallel.

### 14.6.1 POWER CONTROL (PCON) REGISTER

The Power Control register PCON (address 8Eh) has two Status bits to indicate what type of Reset occurred last.

**FIGURE 14-3: TIME-OUT SEQUENCE ON POWER-UP (DELAYED  $\overline{MCLR}$ ): CASE 1**

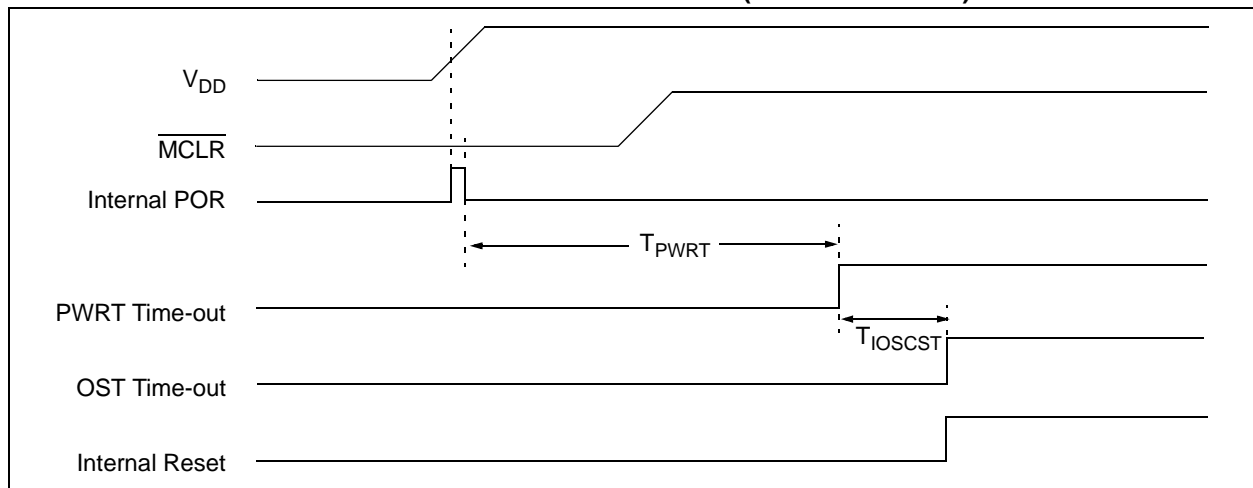

# MCP19110/11

FIGURE 14-4: TIME-OUT SEQUENCE ON POWER-UP (DELAYED  $\overline{\text{MCLR}}$ ): CASE 2

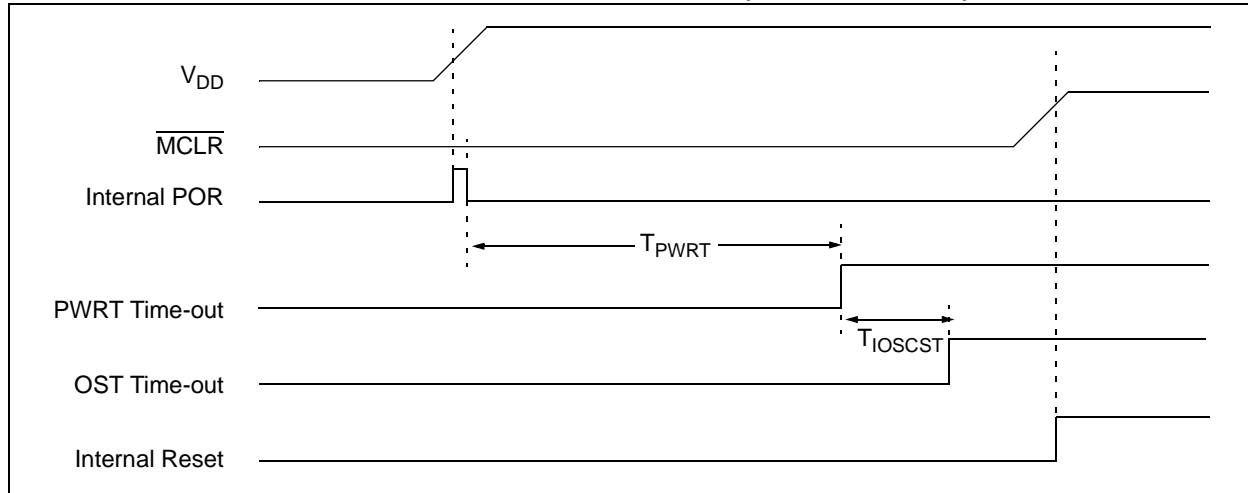
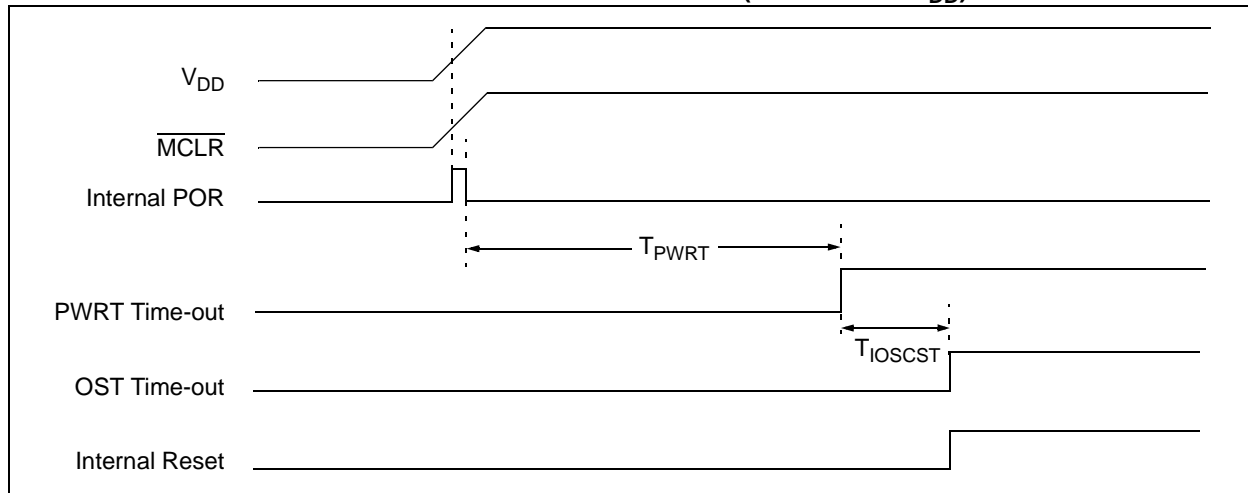

FIGURE 14-5: TIME-OUT SEQUENCE ON POWER-UP ( $\overline{\text{MCLR}}$  WITH  $V_{\text{DD}}$ )





**TABLE 14-3: INITIALIZATION CONDITION FOR REGISTERS**

Register	Address	Power-on Reset	MCLR Reset WDT Reset	Wake-up from Sleep through Interrupt Wake-up from Sleep through WDT Time-out
W	—	xxxx xxxx	uuuu uuuu	uuuu uuuu
INDF	00h/80h/ 100h/180h	xxxx xxxx	xxxx xxxx	uuuu uuuu
TMR0	01h/101h	xxxx xxxx	uuuu uuuu	uuuu uuuu
PCL	02h/82h/ 102h/182h	0000 0000	0000 0000	PC + 1 <sup>(3)</sup>
STATUS	03h/83h/ 103h/183h	0001 1xxx	000q quuu <sup>(4)</sup>	uuuq quuu <sup>(4)</sup>
FSR	04h/84h/ 104h/184h	xxxx xxxx	uuuu uuuu	uuuu uuuu
PORTGPA	05h	xxxx xxxx	uuuu uuuu	uuuu uuuu
PORTGPB	06h	xxx- xxxx	uuu- uuuu	uuu- uuuu
PIR1	07h	-000 --00	-000 --00	-uuu --uu
PIR2	08h	0-00 --00	0-00 --00	u-uu --uu
PCON	09h	---- -qq-	---- -uu-	---- -uu-
PCLATH	0Ah/8Ah/ 10Ah/18Ah	---0 0000	---0 0000	---u uuuu
INTCON	0Bh/8Bh/ 10Bh/18Bh	0000 000x	0000 000u	uuuu uuuu <sup>(2)</sup>
TMR1L	0Ch	xxxx xxxx	uuuu uuuu	uuuu uuuu
TMR1H	0Dh	xxxx xxxx	uuuu uuuu	uuuu uuuu
T1CON	0Eh	--00 --00	--uu --uu	--uu --uu
TMR2	0Fh	0000 0000	uuuu uuuu	uuuu uuuu
T2CON	10h	---- -000	---- -000	---- -uuu
PR2	11h	1111 1111	1111 1111	uuuu uuuu
PWMPHL	13h	xxxx xxxx	uuuu uuuu	uuuu uuuu
PWMPHH	14h	xxxx xxxx	uuuu uuuu	uuuu uuuu
PWMRL	15h	xxxx xxxx	uuuu uuuu	uuuu uuuu
PWMRH	16h	xxxx xxxx	uuuu uuuu	uuuu uuuu
OVCCON	19h	0000 0000	0000 0000	uuuu uuuu
OVFCON	1Ah	0--0 0000	0--0 0000	u--u uuuu
OSCTUNE	1Bh	---0 0000	---0 0000	---u uuuu
ADRESL <sup>(1)</sup>	1Ch	xxxx xxxx	uuuu uuuu	uuuu uuuu
ADRESH <sup>(1)</sup>	1Dh	---- --xx	---- --uu	---- --uu
ADCON0 <sup>(1)</sup>	1Eh	-000 0000	-000 0000	-uuu uuuu
ADCON1 <sup>(1)</sup>	1Fh	-000 ----	-000 ----	-uuu ----
OPTION_REG	81h/181h	1111 1111	1111 1111	uuuu uuuu
TRISGPA	85h	1111 1111	1111 1111	uuuu uuuu
TRISGPB	86h	1111 1111	1111 1111	uuuu uuuu

**Legend:** u = unchanged, x = unknown, - = unimplemented bit, reads as '0', q = value depends on condition.

**Note 1:** If V<sub>DD</sub> goes too low, Power-on Reset will be activated and registers will be affected differently.

**2:** One or more bits in INTCON and/or PIRx will be affected (to cause wake-up).

**3:** When the wake-up is due to an interrupt and the GIE bit is set, the PC is loaded with the interrupt vector (0004h).

**4:** See Table 14-5 for Reset value for specific condition.

# MCP19110/11

**TABLE 14-3: INITIALIZATION CONDITION FOR REGISTERS (CONTINUED)**

Register	Address	Power-on Reset	MCLR Reset WDT Reset	Wake-up from Sleep through Interrupt Wake-up from Sleep through WDT Time-out
PIE1	87h	-000 --00	-000 --00	-uuu --uu
PIE2	88h	0-00 --00	0-00 --00	u-uu --uu
APFCON	89h	---- ---0	---- ---0	---- ---u
VINLVL	90h	0-xx xxxx	0-uu uuuu	u-uu uuuu
OCCON	91h	0xxx xxxx	0uuu uuuu	uuuu uuuu
CSGSCON	93h	-xxx xxxx	-uuu uuuu	-uuu uuuu
CSDGCON	95h	0--- xxxx	0--- uuuu	u--- uuuu
VZCCON	97h	xxxx xxxx	uuuu uuuu	uuuu uuuu
CMPZCON	98h	xxxx xxxx	uuuu uuuu	uuuu uuuu
OUVCON	99h	xxxx xxxx	uuuu uuuu	uuuu uuuu
OOVCON	9Ah	xxxx xxxx	uuuu uuuu	uuuu uuuu
DEADCON	9Bh	xxxx xxxx	uuuu uuuu	uuuu uuuu
SLPCRCON	9Ch	xxxx xxxx	uuuu uuuu	uuuu uuuu
SLVGNCON	9Dh	---x xxxx	---u uuuu	---u uuuu
RELEFF	9Eh	0000 0000	0000 0000	uuuu uuuu
WPUGPA	105h	--1- 1111	--u- uuuu	--u- uuuu
WPUGPB	106h	1111 -11-	uuuu -uu-	uuuu -uu-
PE1	107h	0000 1100	0000 1100	uuuu uuuu
BUFFCON	108h	000- 0000	000- 0000	uuu- uuuu
ABECON	109h	0000 0000	0000 0000	uuuu uuuu
SSPADD	110h	0000 0000	0000 0000	uuuu uuuu
SSPBUF	111h	xxxx xxxx	uuuu uuuu	uuuu uuuu
SSPCON1	112h	0000 0000	0000 0000	uuuu uuuu
SSPCON2	113h	0000 0000	0000 0000	uuuu uuuu
SSPCON3	114h	0000 0000	0000 0000	uuuu uuuu
SSPMSK	115h	1111 1111	1111 1111	uuuu uuuu
SSPSTAT	116h			
SSPADD2	117h	0000 0000	0000 0000	uuuu uuuu
SSPMSK2	118h	1111 1111	1111 1111	uuuu uuuu
IOCA	185h	0000 0000	0000 0000	uuuu uuuu
IOCB	186h	0000 -000	0000 -000	uuuu -uuu
ANSELA	187h	---- 1111	---- 1111	---- uuuu
ANSELB	188h	--11 -11-	--11 -11-	--uu -uu-
PMCON1	190h	-0-- -000	-0-- -000	-u-- -uuu
PMCON2	191h	---- ----	---- ----	---- ----
PMADRL	192h	0000 0000	0000 0000	uuuu uuuu
PMADRH	193h	---- -000	---- -000	---- -uuu
PMDATL	194h	0000 0000	0000 0000	uuuu uuuu

**Legend:** u = unchanged, x = unknown, - = unimplemented bit, reads as '0', q = value depends on condition.

- Note** 1: If  $V_{DD}$  goes too low, Power-on Reset will be activated and registers will be affected differently.  
 2: One or more bits in INTCON and/or PIRx will be affected (to cause wake-up).  
 3: When the wake-up is due to an interrupt and the GIE bit is set, the PC is loaded with the interrupt vector (0004h).  
 4: See Table 14-5 for Reset value for specific condition.

**TABLE 14-3: INITIALIZATION CONDITION FOR REGISTERS (CONTINUED)**

Register	Address	Power-on Reset	MCLR Reset WDT Reset	Wake-up from Sleep through Interrupt Wake-up from Sleep through WDT Time-out
PMDATH	195h	--00 0000	--00 0000	--uu uuuu
OSCCAL	198h	-xxx xxxxx	-uuu uuuu	-uuu uuuu
DOVCAL	199h	---- xxxxx	---- uuuu	---- uuuu
TTACAL	19Ah	---- xxxxx	---- uuuu	---- uuuu
BGRCAL	19Bh	---- xxxxx	---- uuuu	---- uuuu
VROCAL	19Ch	---- xxxxx	---- uuuu	---- uuuu
ZROCAL	19Dh	---- xxxxx	---- uuuu	---- uuuu
ATSTCON	19F	1--- 0001	1--- 0001	u--- uuuu

**Legend:** u = unchanged, x = unknown, - = unimplemented bit, reads as '0', q = value depends on condition.

**Note 1:** If  $V_{DD}$  goes too low, Power-on Reset will be activated and registers will be affected differently.

**2:** One or more bits in INTCON and/or PIRx will be affected (to cause wake-up).

**3:** When the wake-up is due to an interrupt and the GIE bit is set, the PC is loaded with the interrupt vector (0004h).

**4:** See Table 14-5 for Reset value for specific condition.

## 14.7 Determining the Cause of a Reset

Upon any Reset, multiple bits in the STATUS and PCON register are updated to indicate the cause of the Reset. Table 14-4 and Table 14-5 show the Reset conditions of these registers.

**TABLE 14-4: RESET STATUS BITS AND THEIR SIGNIFICANCE**

POR	TO	PD	Condition
0	1	1	Power-on Reset
u	0	u	WDT Reset
u	0	0	WDT Wake-up from Sleep
u	1	0	Interrupt Wake-up from Sleep
u	u	u	MCLR Reset during normal operation
u	1	0	MCLR Reset during Sleep
0	0	x	Not allowed. TO is set on POR
0	x	0	Not allowed. PD is set on POR

**TABLE 14-5: RESET CONDITION FOR SPECIAL REGISTERS (Note 2)**

Condition	Program Counter	STATUS Register	PCON Register
Power-on Reset	0000h	0001 1xxx	---- -u0-
MCLR Reset during normal operation	0000h	000u uuuu	---- -uu-
MCLR Reset during Sleep	0000h	0001 0uuu	---- -uu-
WDT Reset	0000h	0000 uuuu	---- -uu-
WDT Wake-up from Sleep	PC + 1	uuu0 0uuu	---- -uu-
Interrupt Wake-up from Sleep	PC + 1 <sup>(1)</sup>	uuu1 0uuu	---- -uu-

**Legend:** u = unchanged, x = unknown, - = unimplemented bit, reads as '0'.

**Note 1:** When the wake-up is due to an interrupt and Global Enable bit (GIE) is set, the return address is pushed on the stack and PC is loaded with the interrupt vector (0004h) after execution of PC + 1.

**2:** If a Status bit is not implemented, that bit will be read as '0'.

# MCP19110/11

## 14.8 Power Control (PCON) Register

The Power Control (PCON) register contains flag bits to differentiate between a:

- Power-on Reset ( $\overline{\text{POR}}$ )
- Overtemperature ( $\overline{\text{OT}}$ )

The PCON register bits are shown in [Register 14-1](#).

**REGISTER 14-1: PCON – POWER CONTROL REGISTER**

U-0	U-0	U-0	U-0	U-0	R/W-0	R/W-0	U-0
—	—	—	—	—	$\overline{\text{OT}}$	$\overline{\text{POR}}$	—
bit 7							bit 0

**Legend:**

R = Readable bit	W = Writable bit	U = Unimplemented bit, read as '0'
-n = Value at POR	'1' = Bit is set	'0' = Bit is cleared
		x = Bit is unknown

- bit 7-3 **Unimplemented:** Read as '0'
- bit 2 **OT:** Overtemperature Reset Status bit  
1 = No Overtemperature Reset occurred  
0 = An Overtemperature Reset occurred (must be set in software after an Overtemperature occurs)
- bit 1 **POR:** Power-on Reset Status bit  
1 = No Power-on Reset occurred  
0 = A Power-on Reset occurred (must be set in software after a Power-on Reset occurs)
- bit 0 **Unimplemented:** Read as '0'

**TABLE 0-1: SUMMARY OF REGISTERS ASSOCIATED WITH RESETS**

Name	Bit 7	Bit 6	Bit 5	Bit 4	Bit 3	Bit 2	Bit 1	Bit 0	Register on Page
PCON	—	—	—	—	—	$\overline{\text{OT}}$	$\overline{\text{POR}}$	—	<a href="#">92</a>
STATUS	IPR	RP1	RP0	$\overline{\text{TO}}$	$\overline{\text{PD}}$	Z	DC	C	<a href="#">71</a>

**Legend:** — = unimplemented bit, reads as '0'. Shaded cells are not used by Resets.

**Note 1:** Other (non Power-up) Resets include  $\overline{\text{MCLR}}$  Reset and Watchdog Timer Reset during normal operation.

## 15.0 INTERRUPTS

The MCP19110/11 has multiple sources of interrupt:

- External Interrupt (INT pin)
- Interrupt-On-Change (IOC) Interrupts
- Timer0 Overflow Interrupt
- Timer1 Overflow Interrupt
- Timer2 Match Interrupt
- ADC Interrupt
- System Overvoltage Error
- System Undervoltage Error
- System Overcurrent Error
- SSP
- BCL
- System Input Undervoltage Error

The Interrupt Control register (INTCON) and Peripheral Interrupt Request Registers (PIRx) record individual interrupt requests in flag bits. The INTCON register also has individual and global interrupt enable bits.

The Global Interrupt Enable bit, GIE of the INTCON register, enables (if set) all unmasked interrupts, or disables (if cleared) all interrupts. Individual interrupts can be disabled through their corresponding enable bits in the INTCON register and PIEx registers. GIE is cleared on Reset.

When an interrupt is serviced, the following actions occur automatically:

- The GIE is cleared to disable any further interrupt.
- The return address is pushed onto the stack.
- The PC is loaded with 0004h.

The firmware within the Interrupt Service Routine (ISR) should determine the source of the interrupt by polling the interrupt flag bits. The interrupt flag bits must be cleared before exiting the ISR, to avoid repeated interrupts. Because the GEI bit is cleared, any interrupt that occurs while executing the ISR will be recorded through its interrupt flag, but will not cause the processor to redirect to the interrupt vector.

- Note 1:** Individual interrupt flag bits are set, regardless of the status of their corresponding mask bit or the GIE bit.
- 2:** When an instruction that clears the GIE bit is executed, any interrupts that were pending for execution in the next cycle are ignored. The interrupts, which were ignored, are still pending to be serviced when the GIE bit is set again.

The `RETFIE` instruction exists the ISR by popping the previous address from the stack, restoring the saved context from the shadow registers and setting the GIE bit.

For additional information on a specific Interrupt's operation, refer to its Peripheral chapter.

## 15.1 Interrupt Latency

For external interrupt events, such as the INT pin or PORTGPx change interrupt, the interrupt latency will be three or four instruction cycles. The exact latency depends upon when the interrupt event occurs (see [Figure 15-2](#)). The latency is the same for one or two-cycle instructions.

## 15.2 GPA2/INT Interrupt

The external interrupt on the GPA2/INT pin is edge-triggered; either on the rising edge, if the INTEDG bit of the OPTION register is set, or the falling edge, if the INTEDG bit is cleared. When a valid edge appears on the GPA2/INT pin, the INTF bit of the INTCON register is set. This interrupt can be disabled by clearing the INTE control bit of the INTCON register. The INTF bit must be cleared by software in the Interrupt Service Routine before re-enabling this interrupt. The GPA2/INT interrupt can wake-up the processor from Sleep, if the INTE bit was set prior to going into Sleep. See [Section 16.0 "Power-Down Mode \(Sleep\)"](#) for details on Sleep, and [Section 16.1 "Wake-up from Sleep"](#) for timing of wake-up from Sleep through GPA2/INT interrupt.

**Note:** The ANSEL register must be initialized to configure an analog channel as a digital input. Pins configured as analog inputs will read '0' and cannot generate an interrupt.

# MCP19110/11

**FIGURE 15-1: INTERRUPT LOGIC**

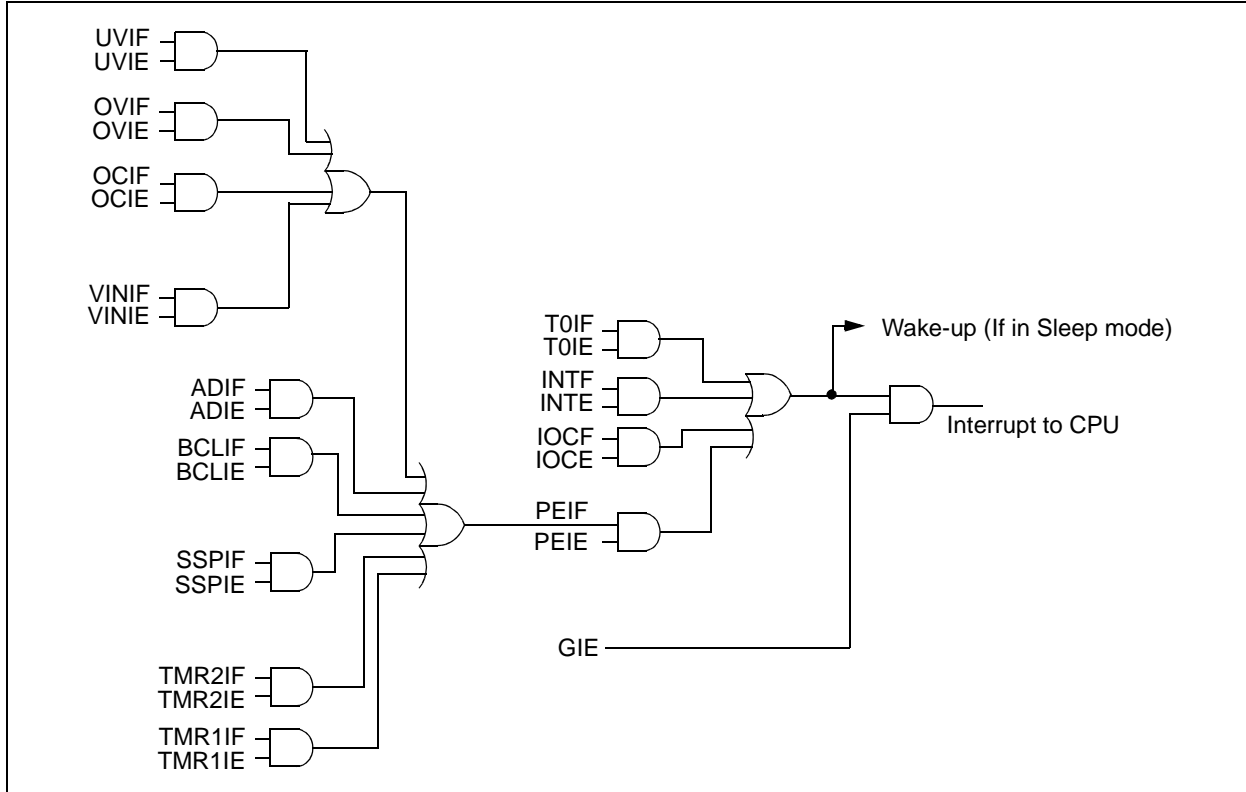

**FIGURE 15-2: INT PIN INTERRUPT TIMING**

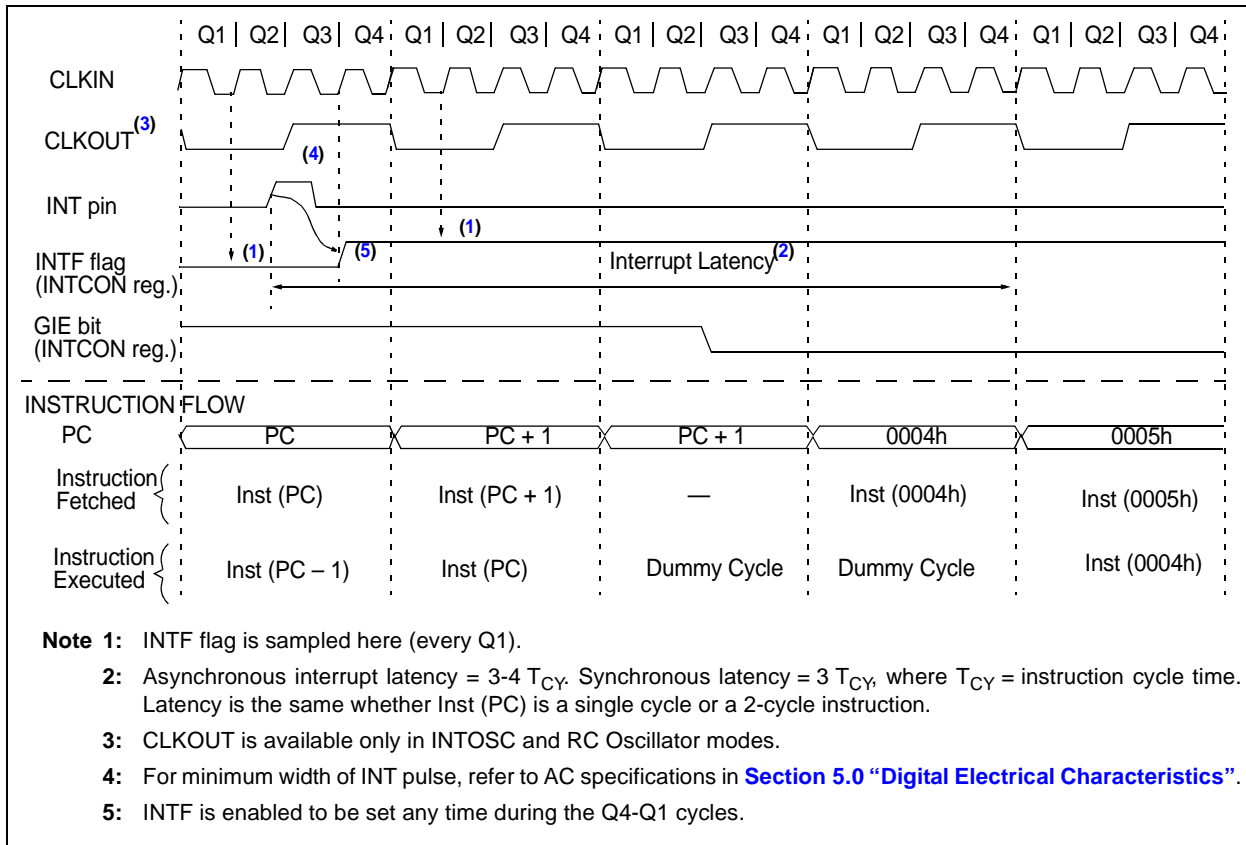

## 15.3 Interrupt Control Registers

### 15.3.1 INTCON REGISTER

The INTCON register is a readable and writable register, that contains the various enable and flag bits for the TMR0 register overflow, interrupt-on-change and external INT pin interrupts.

**Note:** Interrupt flag bits are set when an interrupt condition occurs, regardless of the state of its corresponding enable bit or the Global Enable bit, GIE, of the INTCON register. User software should ensure the appropriate interrupt flag bits are clear prior to enabling an interrupt.

#### REGISTER 15-1: INTCON – INTERRUPT CONTROL REGISTER

R/W-0	R/W-0	R/W-0	R/W-0	R/W-0	R/W-0	R/W-0	R/W-x
GIE	PEIE	TOIE	INTE	IOCE	TOIF	INTF	IOCF
bit 7							bit 0

**Legend:**

R = Readable bit                      W = Writable bit                      U = Unimplemented bit, read as '0'  
 -n = Value at POR                      '1' = Bit is set                      '0' = Bit is cleared                      x = Bit is unknown

- bit 7            **GIE:** Global Interrupt Enable bit  
                  1 = Enables all unmasked interrupts  
                  0 = Disables all interrupts
- bit 6            **PEIE:** Peripheral Interrupt Enable bit  
                  1 = Enables all unmasked peripheral interrupts  
                  0 = Disables all peripheral interrupts
- bit 5            **TOIE:** TMR0 Overflow Interrupt Enable bit  
                  1 = Enables the TMR0 interrupt  
                  0 = Disables the TMR0 interrupt
- bit 4            **INTE:** INT External Interrupt Enable bit  
                  1 = Enables the INT external interrupt  
                  0 = Disables the INT external interrupt
- bit 3            **IOCE:** Interrupt-on-Change Enable bit<sup>(1)</sup>  
                  1 = Enables the interrupt-on-change  
                  0 = Disables the interrupt-on-change
- bit 2            **TOIF:** TMR0 Overflow Interrupt Flag bit<sup>(2)</sup>  
                  1 = TMR0 register has overflowed (must be cleared in software)  
                  0 = TMR0 register did not overflow
- bit 1            **INTF:** External Interrupt Flag bit  
                  1 = The external interrupt occurred (must be cleared in software)  
                  0 = The external interrupt did not occur
- bit 0            **IOCF:** Interrupt-on-Change Interrupt Flag bit  
                  1 = When at least one of the interrupt-on-change pins changed state  
                  0 = None of the interrupt-on-change pins have changed state

- Note 1:** IOC register must also be enabled.  
**2:** TOIF bit is set when TMR0 rolls over. TMR0 is unchanged on Reset and should be initialized before clearing TOIF bit.

# MCP19110/11

## 15.3.1.1 PIE1 Register

The PIE1 register contains the Peripheral Interrupt Enable bits, as shown in [Register 15-2](#).

**Note 1:** Bit PEIE of the INTCON register must be set to enable any peripheral interrupt.

**REGISTER 15-2: PIE1 – PERIPHERAL INTERRUPT ENABLE REGISTER 1**

U-0	R/W-0	R/W-0	R/W-0	U-0	U-0	R/W-0	R/W-0
—	ADIE	BCLIE	SSPIE	—	—	TMR2IE	TMR1IE
bit 7							bit 0

**Legend:**

R = Readable bit

W = Writable bit

U = Unimplemented bit, read as '0'

-n = Value at POR

'1' = Bit is set

'0' = Bit is cleared

x = Bit is unknown

- bit 7           **UNIMPLEMENTED:** Read as '0'
- bit 6-0       **ADIE:** ADC Interrupt Enable bit
  - 1 = Enables the ADC interrupt
  - 0 = Disables the ADC interrupt
- bit 6-0       **BCLIE:** MSSP Bus Collision Interrupt Enable bit
  - 1 = Enables the MSSP Bus Collision Interrupt
  - 0 = Disables the MSSP Bus Collision Interrupt
- bit 6-0       **SSPIE:** Synchronous Serial Port (MSSP) Interrupt Enable bit
  - 1 = Enables the MSSP interrupt
  - 0 = Disables the MSSP interrupt
- bit 6-0       **UNIMPLEMENTED:** Read as 0
- bit 6-0       **TMR2IE:** Timer2 Interrupt Enable
  - 1 = Enables the Timer2 interrupt
  - 0 = Disables the Timer2 interrupt
- bit 6-0       **TMR1IE:** Timer1 Interrupt Enable
  - 1 = Enables the Timer1 interrupt
  - 0 = Disables the Timer1 interrupt



## 15.3.1.2 PIE2 Register

The PIE2 register contains the Peripheral Interrupt Enable bits, as shown in [Register 15-3](#).

**Note 1:** Bit PEIE of the INTCON register must be set to enable any peripheral interrupt.

### REGISTER 15-3: PIE2 – PERIPHERAL INTERRUPT ENABLE REGISTER 2

U-0	U-0	R/W-0	R/W-0	U-0	U-0	R/W-0	U-0
UVIE	—	OCIE	OVIE	—	—	VINIE	—
bit 7							bit 0

**Legend:**

R = Readable bit                      W = Writable bit                      U = Unimplemented bit, read as '0'  
 -n = Value at POR                      '1' = Bit is set                      '0' = Bit is cleared                      x = Bit is unknown

- bit 7            **UVIE:** Output Undervoltage Interrupt enable bit  
                  1 = Enables the UV interrupt  
                  0 = Disables the UV interrupt
- bit 6            **UNIMPLEMENTED:** Read as '0'
- bit 5            **OCIE:** Output Overcurrent Interrupt enable bit  
                  1 = Enables the OC interrupt  
                  0 = Disables the OC interrupt
- bit 4            **OVIE:** Output Overvoltage Interrupt enable bit  
                  1 = Enables the OV interrupt  
                  0 = Disables the OV interrupt
- bit 3-2        **UNIMPLEMENTED:** Read as '0'
- bit 1            **VINIE:**  $V_{IN}$  UVLO Interrupt Enable  
                  1 = Enables the  $V_{IN}$  UVLO interrupt  
                  0 = Disables the  $V_{IN}$  UVLO interrupt
- bit 0            **UNIMPLEMENTED:** Read as '0'

# MCP19110/11

## 15.3.1.3 PIR1 Register

The PIR1 register contains the Peripheral Interrupt Flag bits, as shown in [Register 15-4](#).

**Note 1:** Interrupt flag bits are set when an interrupt condition occurs, regardless of the state of its corresponding enable bit or the Global Enable bit, GIE of the INTCON register. User software should ensure the appropriate interrupt flag bits are clear prior to enabling an interrupt.

### REGISTER 15-4: PIR1 – PERIPHERAL INTERRUPT FLAG REGISTER 1

U-0	R/W-0	R/W-0	R/W-0	U-0	U-0	R/W-0	R/W-0
—	ADIF	BCLIF	SSPIF	—	—	TMR2IF	TMR1IF
bit 7							bit 0

#### Legend:

R = Readable bit

W = Writable bit

U = Unimplemented bit, read as '0'

-n = Value at POR

'1' = Bit is set

'0' = Bit is cleared

x = Bit is unknown

- bit 7      **UNIMPLEMENTED:** Read as '0'
- bit 6      **ADIF:** ADC Interrupt Flag bit  
1 = ADC conversion complete  
0 = ADC conversion has not completed or has not been started
- bit 5      **BCLIF:** MSSP Bus Collision Interrupt Flag bit  
1 = Interrupt is pending  
0 = Interrupt is not pending
- bit 4      **SSPIF:** Synchronous Serial Port (MSSP) Interrupt Flag bit  
1 = Interrupt is pending  
0 = Interrupt is not pending
- bit 3-2    **UNIMPLEMENTED:** Read as '0'
- bit 1      **TMR2IF:** Timer2 to PR2 Match Interrupt Flag  
1 = Timer2 to PR2 match occurred (must be cleared in software)  
0 = Timer2 to PR2 match did not occur
- bit 0      **TMR1IF:** Timer1 Interrupt Flag  
1 = Timer1 rolled over (must be cleared in software)  
0 = Timer1 has not rolled over

## 15.3.1.4 PIR2 Register

The PIR2 register contains the Peripheral Interrupt Flag bits, as shown in [Register 15-5](#).

**Note 1:** Interrupt flag bits are set when an interrupt condition occurs, regardless of the state of its corresponding enable bit or the Global Enable bit, GIE of the INTCON register. User software should ensure the appropriate interrupt flag bits are clear prior to enabling an interrupt.

**REGISTER 15-5: PIR2 – PERIPHERAL INTERRUPT FLAG REGISTER 2**

R/W-0	U-0	R/W-0	R/W-0	U-0	U-0	R/W-0	U-0
UVIF	—	OCIF	OVIF	—	—	VINIF	—
bit 7							bit 0

**Legend:**

R = Readable bit	W = Writable bit	U = Unimplemented bit, read as '0'
-n = Value at POR	'1' = Bit is set	'0' = Bit is cleared      x = Bit is unknown

- bit 7      **UVIF:** Output undervoltage error interrupt flag bit  
           1 = Output undervoltage error has occurred  
           0 = Output undervoltage error has not occurred
- bit 6      **UNIMPLEMENTED:** Read as '0'
- bit 5      **OCIF:** Output overcurrent error interrupt flag bit  
           1 = Output overcurrent error has occurred  
           0 = Output overcurrent error has not occurred
- bit 4      **OVIF:** Output overvoltage error interrupt flag bit  
           1 = Output overvoltage error has occurred  
           0 = Output overvoltage error has not occurred
- bit 3-2    **UNIMPLEMENTED:** Read as '0'
- bit 1      **VINIF:**  $V_{IN}$  Status bit  
           1 =  $V_{IN}$  is below acceptable level  
           0 =  $V_{IN}$  is at acceptable level
- bit 0      **UNIMPLEMENTED:** Read as '0'

**TABLE 15-1: SUMMARY OF REGISTERS ASSOCIATED WITH INTERRUPTS**

Name	Bit 7	Bit 6	Bit 5	Bit 4	Bit 3	Bit 2	Bit 1	Bit 0	Register on Page
INTCON	GIE	PEIE	T0IE	INTE	IOCE	T0IF	INTF	IOCF	<a href="#">95</a>
OPTION_REG	$\overline{RAPU}$	INTEDG	T0CE	T0SE	PSA	PS2	PS1	PS0	<a href="#">77</a>
PIE1	—	ADIE	BCLIE	SSPIE	—	—	TMR2IE	TMR1IE	<a href="#">96</a>
PIE2	UVIE	—	OCIE	OVIE	—	—	VINIE	—	<a href="#">97</a>
PIR1	—	ADIF	BCLIF	SSPIF	—	—	TMR2IF	TMR1IF	<a href="#">98</a>
PIR2	UVIF	—	OCIF	OVIF	—	—	VINIF	—	<a href="#">99</a>

**Legend:** — = unimplemented locations read as '0'. Shaded cells are not used by Interrupts.

# MCP19110/11

---

## 15.4 Context Saving During Interrupts

During an interrupt, only the return PC value is saved on the stack. Typically, users may wish to save key registers during an interrupt (e.g., W and STATUS registers). This must be implemented in software.

Temporary holding registers W\_TEMP and STATUS\_TEMP should be placed in the last 16 bytes of GPR (see [Figure 11-2](#)). These 16 locations are common to all banks and do not require banking. This makes context save and restore operations simpler. The code shown in [Example 15-1](#) can be used to:

- Store the W register
- Store the STATUS register
- Execute the ISR code
- Restore the Status (and Bank Select Bit register)
- Restore the W register

**Note:** The MCP19110/11 device does not require saving the PCLATH. However, if computed GOTOS are used in both the ISR and the main code, the PCLATH must be saved and restored in the ISR.

### EXAMPLE 15-1: SAVING STATUS AND W REGISTERS IN RAM

```
MOVWF  W_TEMP          ;Copy W to TEMP register
SWAPF  STATUS,W        ;Swap status to be saved into W
                          ;Swaps are used because they do not affect the status bits
MOVWF  STATUS_TEMP     ;Save status to bank zero STATUS_TEMP register
:
:(ISR)                  ;Insert user code here
:
SWAPF  STATUS_TEMP,W   ;Swap STATUS_TEMP register into W
                          ;(sets bank to original state)
MOVWF  STATUS          ;Move W into STATUS register
SWAPF  W_TEMP,F        ;Swap W_TEMP
SWAPF  W_TEMP,W        ;Swap W_TEMP into W
```

## 16.0 POWER-DOWN MODE (SLEEP)

The Power-Down mode is entered by executing a `SLEEP` instruction.

Upon entering Sleep mode, the following conditions exist:

1. WDT will be cleared but keeps running, if enabled for operation during Sleep.
2.  $\overline{\text{PD}}$  bit of the STATUS register is cleared.
3.  $\overline{\text{TO}}$  bit of the STATUS register is set.
4. CPU clock is not disabled.
5. Timer1 oscillator is unaffected, and peripherals that operate from it may continue operation in Sleep.
6. ADC is unaffected.
7. I/O ports maintain the status they had before `SLEEP` was executed (driving high, low or high-impedance).
8. Resets other than WDT are not affected by Sleep mode.
9. Analog circuitry is unaffected by execution of `SLEEP` instruction.

Refer to individual chapters for more details on peripheral operation during Sleep.

To minimize current consumption, the following conditions should be considered:

- I/O pins should not be floating
- External circuitry sinking current from I/O pins
- Internal circuitry sourcing current from I/O pins
- Current draw from pins with internal weak pull-ups
- Modules using Timer1 oscillator

I/O pins that are high-impedance inputs should be pulled to  $V_{\text{DD}}$  or GND externally to avoid switching currents caused by floating inputs.

The `SLEEP` instruction does not affect the analog circuitry. The enable state of the analog circuitry does not change with the execution of the `SLEEP` instruction.

Examples of internal circuitry that might be sourcing current include modules, such as the DAC. See [Section 22.0 “Analog-to-Digital Converter \(ADC\) Module”](#) for more information on this module.

## 16.1 Wake-up from Sleep

The device can wake-up from Sleep through one of the following events:

1. External Reset input on  $\overline{\text{MCLR}}$  pin, if enabled
2. POR Reset
3. Watchdog Timer, if enabled
4. Any external interrupt
5. Interrupts by peripherals capable of running during Sleep (see individual peripheral for more information)

The first two events will cause a device Reset. The last three events are considered a continuation of program execution. To determine whether a device Reset or Wake-up event occurred, refer to [Section 14.7 “Determining the Cause of a Reset”](#).

The following peripheral interrupts can wake the device from Sleep:

1. Timer1 interrupt. Timer1 must be operating as an asynchronous counter
2. A/D conversion
3. Interrupt-on-change
4. External Interrupt from INT pin

When the `SLEEP` instruction is being executed, the next instruction ( $\text{PC} + 1$ ) is prefetched. For the device to wake-up through an interrupt event, the corresponding interrupt enable bit must be enabled. Wake-up will occur regardless of the state of the GIE bit. If the GIE bit is disabled, the device continues execution at the instruction after the `SLEEP` instruction. If the GIE bit is enabled, the device executes the instruction after the `SLEEP` instruction, the device will then call the Interrupt Service Routine. In cases where the execution of the instruction following `SLEEP` is not desirable, the user should have an `NOP` after the `SLEEP` instruction.

The WDT is cleared when the device wakes up from Sleep, regardless of the source of wake-up.

# MCP19110/11

## 16.1.1 WAKE-UP USING INTERRUPTS

When global interrupts are disabled (GIE cleared) and any interrupt source has both its interrupt enable bit and interrupt flag bit set, one of the following will occur:

- If the interrupt occurs **before** the execution of a SLEEP instruction:
  - SLEEP instruction will execute as an NOP
  - WDT and WDT prescaler will not be cleared
  - $\overline{TO}$  bit of the STATUS register will not be set
  - $\overline{PD}$  bit of the STATUS register will not be cleared

- If the interrupt occurs **during or after** the execution of a SLEEP instruction:
  - SLEEP instruction will be completely executed
  - Device will immediately wake-up from Sleep
  - WDT and WDT prescaler will be cleared
  - $\overline{TO}$  bit of the STATUS register will be set
  - $\overline{PD}$  bit of the STATUS register will be cleared

Even if the flag bits were checked before executing a SLEEP instruction, it may be possible for flag bits to become set before the SLEEP instruction completes. To determine whether a SLEEP instruction executed, test the PD bit. If the  $\overline{PD}$  bit is set, the SLEEP instruction was executed as an NOP.

**FIGURE 16-1: WAKE-UP FROM SLEEP THROUGH INTERRUPT**

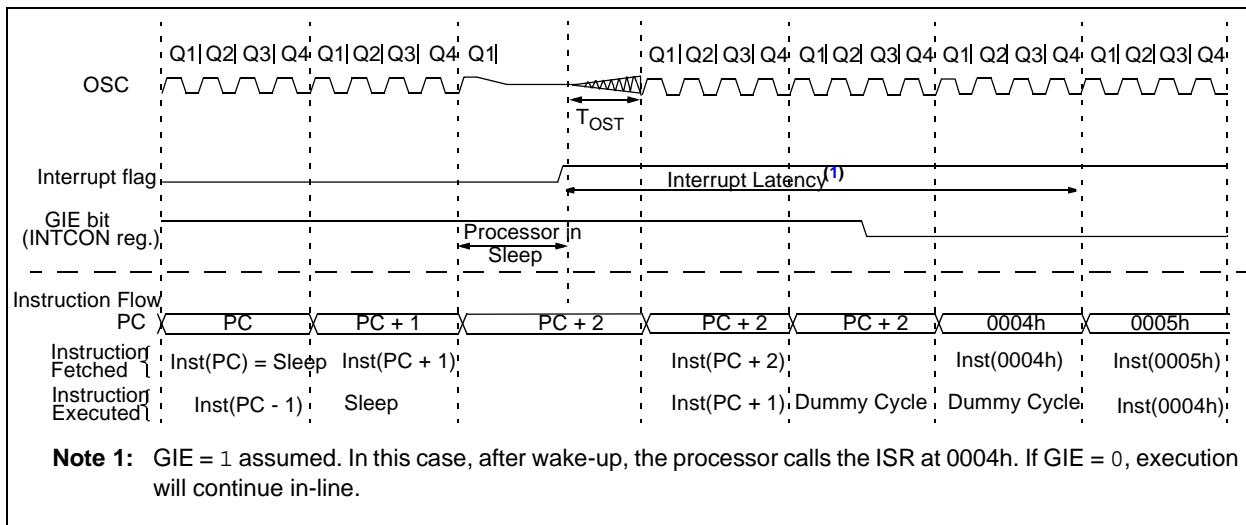

**TABLE 16-1: SUMMARY OF REGISTERS ASSOCIATED WITH POWER-DOWN MODE**

Name	Bit 7	Bit 6	Bit 5	Bit 4	Bit 3	Bit 2	Bit 1	Bit 0	Register on Page
INTCON	GIE	PEIE	T0IE	INTE	IOCE	T0IF	INTF	IOCF	95
IOCA	IOCA7	IOCA6	IOCA5	IOCA4	IOCA3	IOCA2	IOCA1	IOCA0	122
IOCB	IOCB7	IOCB6	IOCB5	IOCB4	—	IOCB2	IOCB1	IOCB0	122
PIE1	—	ADIE	BCLIE	SSPIE	—	—	TMR2IE	TMR1IE	96
PIE2	UVIE	—	OCIE	OVIE	—	—	VINIE	—	97
PIR1	—	ADIF	BCLIF	SSPIF	—	—	TMR2IF	TMR1IF	98
PIR2	UVIF	—	OCIF	OVIF	—	—	VINIF	—	99
STATUS	IRP	RP1	RP0	$\overline{TO}$	$\overline{PD}$	Z	DC	C	71

**Legend:** — = unimplemented, read as '0'. Shaded cells are not used in Power-down mode.

## 17.0 WATCHDOG TIMER (WDT)

The Watchdog Timer is a free-running timer. The WDT is enabled by setting the WDTE bit of the Configuration Word (default setting).

During normal operation, a WDT time-out generates a device Reset. If the device is in Sleep mode, a WDT time-out causes the device to wake-up and continue with normal operation.

The WDT can be permanently disabled by clearing the WDTE bit of the Configuration word. See [Section 12.1 “Configuration Word”](#) for more information.

### 17.1 Watchdog Timer (WDT) Operation

During normal operation, a WDT time-out generates a device RESET. If the device is in SLEEP mode, a WDT time-out causes the device to wake-up and continue with normal operation; this is known as a WDT wake-up. The WDT can be permanently disabled by clearing the WDTE configuration bit.

The postscaler assignment is fully under software control and can be changed during program execution.

### 17.2 WDT Period

The WDT has a nominal time-out period of 18 ms (with no prescaler). The time-out periods vary with temperature,  $V_{DD}$  and process variations from part to part (see [Table 5-4](#)). If longer time-out periods are desired, a prescaler with a division ratio of up to 1:128 can be assigned to the WDT under software control by writing to the OPTION register. Thus, time-out periods up to 2.3 seconds can be realized.

The CLRWDT and SLEEP instructions clear the WDT and the prescaler, if assigned to the WDT, and prevent it from timing out and generating a device Reset.

The  $\overline{TO}$  bit in the STATUS register will be cleared upon a Watchdog Timer time-out.

### 17.3 WDT Programming Considerations

Under worst-case conditions (i.e.,  $V_{DD}$  = Minimum, Temperature = Maximum, Maximum WDT prescaler), it may take several seconds before a WDT time-out occurs.

**FIGURE 17-1: WATCHDOG TIMER WITH SHARED PRESCALER BLOCK DIAGRAM**

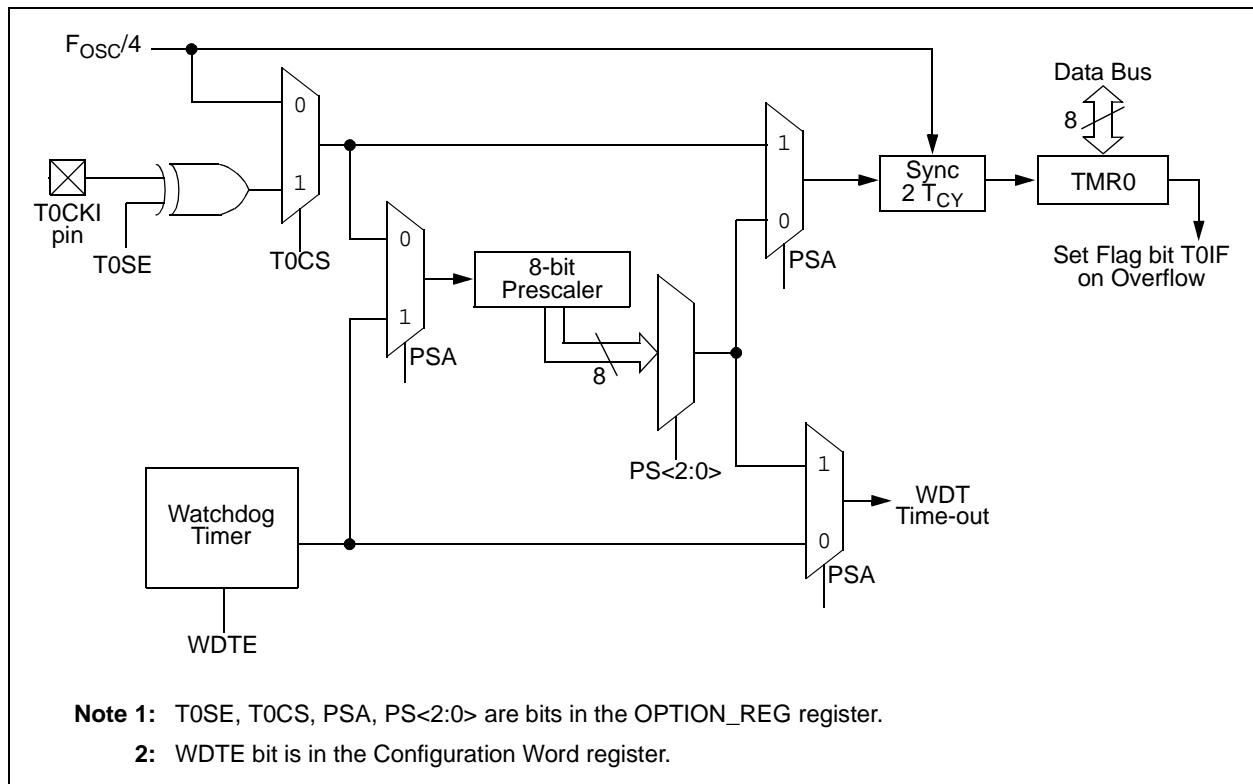

# MCP19110/11

**TABLE 17-1: WDT STATUS**

Conditions	WDT
WDTE = 0	Cleared
CLRWDT Command	
Exit Sleep	

**TABLE 17-2: SUMMARY OF REGISTERS ASSOCIATED WITH WATCHDOG TIMER**

Name	Bit 7	Bit 6	Bit 5	Bit 4	Bit 3	Bit 2	Bit 1	Bit 0	Register on Page
OPTION_REG	$\overline{\text{RAPU}}$	INTEDG	T0CS	T0SE	PSA	PS<2:0>			77

**Legend:** Shaded cells are not used by the Watchdog Timer.

**TABLE 17-3: SUMMARY OF CONFIGURATION WORD ASSOCIATED WITH WATCHDOG TIMER**

Name	Bits	Bit -/7	Bit -/6	Bit 13/5	Bit 12/4	Bit 11/3	Bit 10/2	Bit 9/1	Bit 8/0	Register on Page
CONFIG	13:8	—	—	$\overline{\text{DBGEN}}$	—	WRT1	WRT0	—	—	81
	7:0	—	$\overline{\text{CP}}$	$\overline{\text{MCLRE}}$	$\overline{\text{PWRTE}}$	WDTE	—	—	—	

**Legend:** — = unimplemented location, read as '1'. Shaded cells are not used by Watchdog Timer.



## 18.0 FLASH PROGRAM MEMORY CONTROL

The Flash program memory is readable and writable during normal operation (full  $V_{IN}$  range). This memory is not directly mapped in the register file space. Instead, it is indirectly addressed through the Special Function Registers (SFR) (see [Registers 18-1 to 18-5](#)). There are six SFRs used to read and write this memory:

- PMCON1
- PMCON2
- PMDATL
- PMDATH
- PMADRL
- PMADRH

When interfacing the program memory block, the PMDATL and PMDATH registers form a two-byte word, which holds the 14-bit data for read/write, and the PMADRL and PMADRH registers form a two-byte word, which holds the 13-bit address of the FLASH location being accessed. These devices have 4K words of program Flash with an address range from 0000h to 0FFFh.

The program memory allows single word read and a four-word write. A four-word write automatically erases the row of the location and writes the new data (erase before write).

The write time is controlled by an on-chip timer. The write/erase voltages are generated by an on-chip charge pump rated to operate over the voltage range of the device for byte or word operations.

When the device is code protected, the CPU may continue to read and write the Flash program memory.

Depending on the settings of the Flash Program Memory Enable (WRT<1:0>) bits, the device may or may not be able to write certain blocks of the program memory, however, reads of the program memory are allowed.

When the Flash Program Memory Code Protection ( $\overline{CP}$ ) bit is enabled, the program memory is code protected, and the device programmer (ICSP) cannot access data or program memory.

## 18.1 PMADRH and PMADRL Registers

The PMADRH and PMADRL registers can address up to a maximum of 4K words of program memory.

When selecting a program address value, the Most Significant Byte (MSB) of the address is written to the PMADRH register and the Least Significant Byte (LSB) is written to the PMADRL register.

## 18.2 PMCON1 and PMCON2 Registers

PMCON1 is the control register for the data program memory accesses.

Control bits RD and WR initiate read and write, respectively. These bits cannot be cleared, only set in software. They are cleared in hardware at completion of the read or write operation. The inability to clear the WR bit in software prevents the accidental premature termination of a write operation.

The WREN bit, when set, will allow a write operation. On power-up, the WREN bit is clear.

The CALSEL bit allows the user to read locations in test memory in case there are calibration bits stored in the calibration word locations that need to be transferred to SFR trim registers. The CALSEL bit is only for reads, and if a write operation is attempted with CALSEL = 1, no write will occur.

PMCON2 is not a physical register. Reading PMCON2 will read all '0's. The PMCON2 register is used exclusively in the flash memory write sequence.

# MCP19110/11

## 18.3 Flash Program Memory Control Registers

### REGISTER 18-1: PMDATL: PROGRAM MEMORY DATA LOW BYTE REGISTER

R/W-0	R/W-0	R/W-0	R/W-0	R/W-0	R/W-0	R/W-0	R/W-0
PMDATL<7:0>							
bit 7							bit 0

**Legend:**

R = Readable bit                      W = Writable bit                      U = Unimplemented bit, read as '0'  
-n = Value at POR                      '1' = Bit is set                      '0' = Bit is cleared                      x = Bit is unknown

bit 7-0                      **PMDATL<7:0>**: 8 Least Significant Data bits Read from Program Memory

### REGISTER 18-2: PMADRL: PROGRAM MEMORY ADDRESS LOW BYTE REGISTER

R/W-0	R/W-0	R/W-0	R/W-0	R/W-0	R/W-0	R/W-0	R/W-0
PMADRL<7:0>							
bit 7							bit 0

**Legend:**

R = Readable bit                      W = Writable bit                      U = Unimplemented bit, read as '0'  
-n = Value at POR                      '1' = Bit is set                      '0' = Bit is cleared                      x = Bit is unknown

bit 7-0                      **PMADRL<7:0>**: 8 Least Significant Address bits for Program Memory Read/Write Operation

### REGISTER 18-3: PMDATH: PROGRAM MEMORY DATA HIGH BYTE REGISTER

U-0	U-0	R/W-0	R/W-0	R/W-0	R/W-0	R/W-0	R/W-0
—	—	PMDATH<5:0>					
bit 7							bit 0

**Legend:**

R = Readable bit                      W = Writable bit                      U = Unimplemented bit, read as '0'  
-n = Value at POR                      '1' = Bit is set                      '0' = Bit is cleared                      x = Bit is unknown

bit 7-6                      **Unimplemented**: Read as '0'

bit 5-0                      **PMDATH<5:0>**: 6 Most Significant Data bits Read from Program Memory

## REGISTER 18-4: PMADRH: PROGRAM MEMORY ADDRESS HIGH BYTE REGISTER

U-0	U-0	U-0	U-0	R/W-0	R/W-0	R/W-0	R/W-0
—	—	—	—	PMADRH<3:0>			
bit 7							bit 0

### Legend:

R = Readable bit                      W = Writable bit                      U = Unimplemented bit, read as '0'  
 -n = Value at POR                      '1' = Bit is set                      '0' = Bit is cleared                      x = Bit is unknown

bit 7-4                      **Unimplemented:** Read as '0'

bit 3-0                      **PMADRH<3:0>**: Specifies the 4 Most Significant Address bits or High bits for Program Memory Reads.

## REGISTER 18-5: PMCON1: PROGRAM MEMORY CONTROL REGISTER 1

U-1	R/W-0	U-0	U-0	U-0	R/W-0	R/S-0	R/S-0
—	CALSEL	—	—	—	WREN	WR	RD
bit 7							bit 0

### Legend:

R = Readable bit                      W = Writable bit                      U = Unimplemented bit, read as '0'  
 -n = Value at POR                      '1' = Bit is set                      '0' = Bit is cleared                      x = Bit is unknown  
 S = Bit can only be set

bit 7                      **Unimplemented:** Read as '1'

bit 6                      **CALSEL:** Program Memory calibration space select bit  
                                  1 = Select test memory area for reads only (for loading calibration trim registers)  
                                  0 = Select user area for reads

bit 5-3                      **Unimplemented:** Read as '0'

bit 2                      **WREN:** Program Memory Write Enable bit  
                                  1 = Allows write cycles  
                                  0 = Inhibits write to the Flash Program Memory

bit 1                      **WR:** Write Control bit  
                                  1 = Initiates a write cycle to program memory. (The bit is cleared by hardware when write is complete.  
                                                                       The WR bit can only be set (not cleared) in software.)  
                                  0 = Write cycle to the Flash memory is complete

bit 0                      **RD:** Read Control bit  
                                  1 = Initiates a program memory read. (The read takes one cycle. The RD is cleared in hardware; the  
                                                                       RD bit can only be set (not cleared) in software).  
                                  0 = Does not initiate a Flash memory read

# MCP19110/11

## 18.3.1 READING THE FLASH PROGRAM MEMORY

To read a program memory location, the user must write two bytes of the address to the PMADRL and PMADRH registers, and then set control bit RD (PMCON1<0>). Once the read control bit is set, the program memory Flash controller will use the second instruction cycle after to read the data. This causes the second instruction immediately following the “BSF PMCON1, RD” instruction to be ignored. The data is available, in the very next cycle, in the PMDATL and PMDATH registers; it can be read as two bytes in the following instructions. PMDATL and PMDATH registers will hold this value until another read or until it is written to by the user (during a write operation).

### EXAMPLE 18-1: FLASH PROGRAM READ

```

BANKSELPM_ADR; Change STATUS bits RP1:0 to select bank with PMADR
MOVLWMS_PROG_PM_ADDR;
MOVWFPADRH; MS Byte of Program Address to read
MOVLWLS_PROG_PM_ADDR;
MOVWFPADRL; LS Byte of Program Address to read
BANKSELPMCON1; Bank to containing PMCON1
BSF PMCON1, RD; EE Read

NOP      ; First instruction after BSF PMCON1,RD executes normally

NOP      ; Any instructions here are ignored as program
          ; memory is read in second cycle after BSF PMCON1,RD
          ;
BANKSELPMDATL; Bank to containing PMADRL
MOVFPMDATL, W; W = LS Byte of Program PMDATL
MOVFPMDATH, W; W = MS Byte of Program PMDATL
    
```

FIGURE 18-1: FLASH PROGRAM MEMORY READ CYCLE EXECUTION – NORMAL MODE

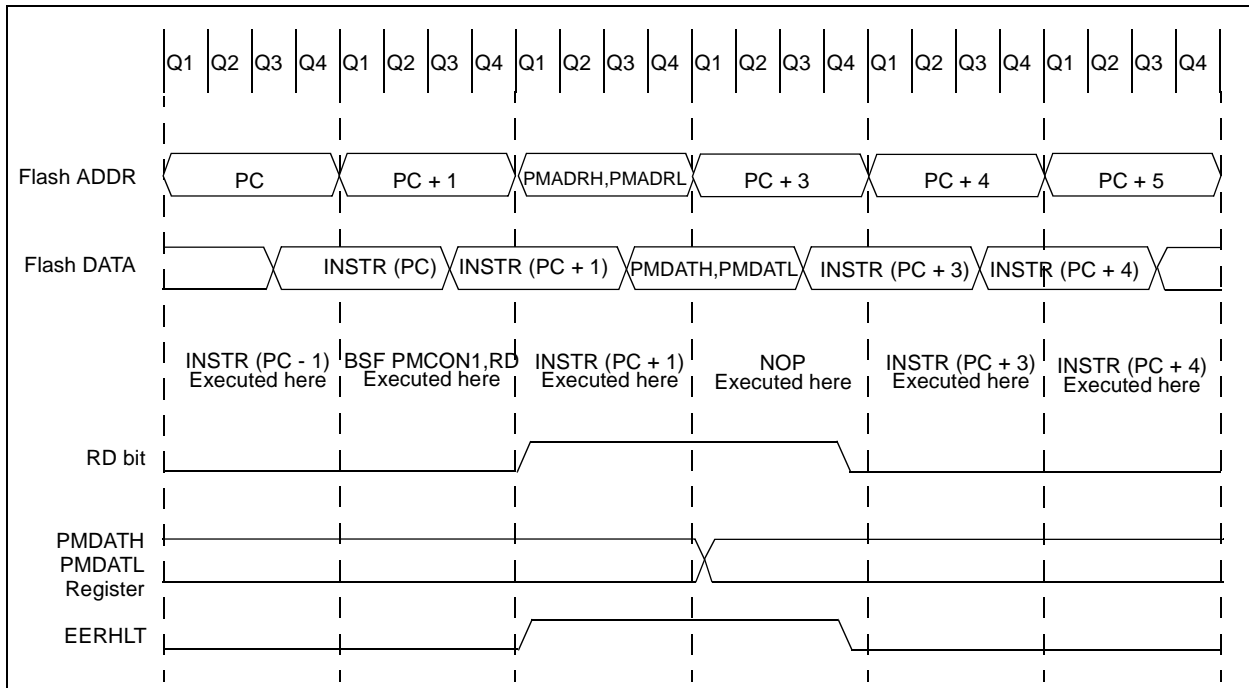

### 18.3.2 WRITING TO THE FLASH PROGRAM MEMORY

A word of the Flash program memory may only be written to if the word is in an unprotected segment of memory, as defined in [Section 12.1 “Configuration Word”](#) (bits WRT1:WRT0).

**Note:** The write protect bits are used to protect the users' program from modification by the user's code. They have no effect when programming is performed by ICSP. The code-protect bits, when programmed for code protection, will prevent the program memory from being written via the ICSP interface.

Flash program memory must be written in four-word blocks. See [Figures 18-2](#) and [18-3](#) for more details. A block consists of four words with sequential addresses, with a lower boundary defined by an address, where  $PMADRL<1:0> = 00$ . All block writes to program memory are done as 16-word erase by four-word write operations. The write operation is edge-aligned and cannot occur across boundaries.

To write program data, it must first be loaded into the buffer registers (see [Figure 18-2](#)). This is accomplished by first writing the destination address to PMADRL and PMADRH, and then writing the data to PMDATL and PMDATH. After the address and data have been set, then the following sequence of events must be executed:

1. Write 55h, then AAh, to PMCON2 (Flash programming sequence).
2. Set the WR control bit of the PMCON1 register.

All four buffer register locations should be written to with correct data. If less than four words are being written to in the block of four words, then a read from the program memory location(s) not being written to must be performed. This takes the data from the program memory location(s) not being written and loads it into the PMDATL and PMDATH registers. Then the sequence of events to transfer data to the buffer registers must be executed.

To transfer data from the buffer registers to the program memory, the PMADRL and PMADRH must point to the last location in the four-word block ( $PMADRL<1:0> = 11$ ). Then the following sequence of events must be executed:

1. Write 55h, then AAh, to PMCON2 (Flash programming sequence).
2. Set control bit WR of the PMCON1 register to begin the write operation.

The user must follow the same specific sequence to initiate the write for each word in the program block, writing each program word in sequence (000, 001, 010, 011). When the write is performed on the last word ( $PMADRL<1:0> = 11$ ), a block of sixteen words is automatically erased and the content of the four-word buffer registers are written into the program memory.

After the “BSF PMCON1, WR” instruction, the processor requires two cycles to set up the erase/write operation. The user must place two NOP instructions after the WR bit is set. Since data is being written to buffer registers, the writing of the first three words of the block appears to occur immediately. The processor will halt internal operations for the typical 4 ms, only during the cycle in which the erase takes place (i.e., the last word of the sixteen-word block erase). This is not Sleep mode, as the clocks and peripherals will continue to run. After the four-word write cycle, the processor will resume operation with the third instruction after the PMCON1 write instruction. The above sequence must be repeated for the higher 12 words.

**Note:** An erase is only initiated for the write of four words, just after a row boundary; or  $PMCON1<WR>$  set with  $PMADRL<3:0> = xxx0011$ .

Refer to [Figure 18-2](#) for a block diagram of the buffer registers and the control signals for test mode.

### 18.3.3 PROTECTION AGAINST SPURIOUS WRITE

There are conditions when the device should not write to the program memory. To protect against spurious writes, various mechanisms have been built in. On power-up, WREN is cleared. Also, the Power-up Timer (72 ms duration) prevents program memory writes.

The write initiate sequence, and the WREN bit, help prevent an accidental write during a power glitch or software malfunction.

#### 18.3.4 OPERATION DURING CODE PROTECT

When the device is code protected, the CPU is able to read and write unscrambled data to the program memory. The test mode access is disabled.

#### 18.3.5 OPERATION DURING WRITE PROTECT

When the program memory is write protected, the CPU can read and execute from the program memory. The portions of program memory that are write protected can not be modified by the CPU using the PMCON registers. The write protection has no effect in ICSP mode.

# MCP19110/11

**FIGURE 18-2: BLOCK WRITES TO 4K FLASH PROGRAM MEMORY**

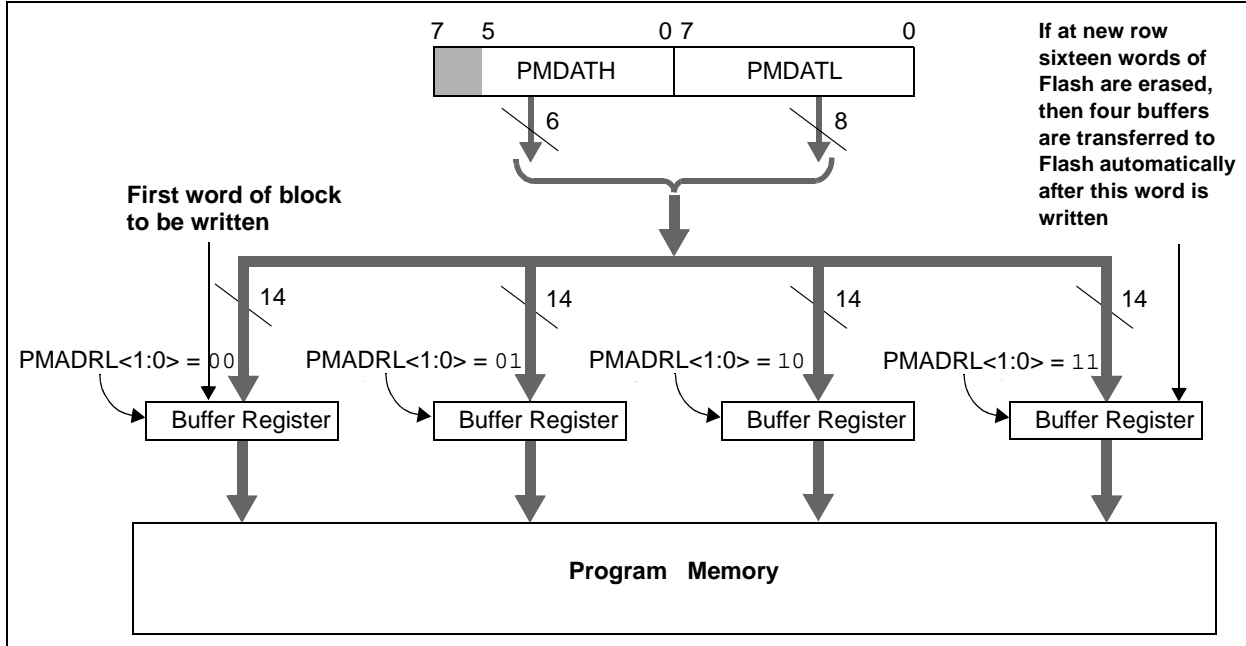

**FIGURE 18-3: FLASH PROGRAM MEMORY LONG WRITE CYCLE EXECUTION**

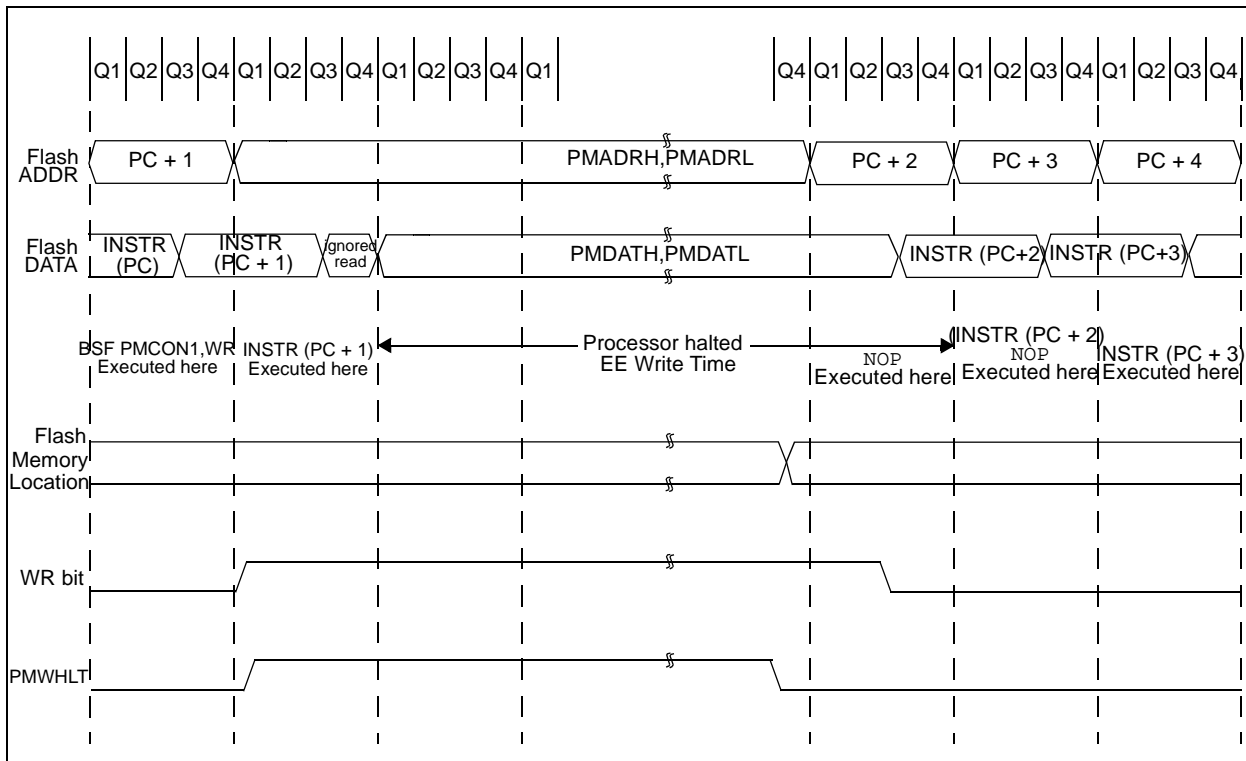

## 19.0 I/O PORTS

In general, when a peripheral is enabled, that pin may not be used as a general purpose I/O pin.

Each port has two registers for its operation. These registers are:

- TRISGPx registers (data direction register)
- PORTGPx registers (reads the levels on the pins of the device)

Some ports may have one or more of the following additional registers. These registers are:

- ANSELx (analog select)
- WPUx (weak pull-up)

Ports with analog functions also have an ANSELx register, which can disable the digital input and save power. A simplified model of a generic I/O port, without the interfaces to other peripherals, is shown in Figure 19-1.

**FIGURE 19-1: GENERIC I/O PORTGPX OPERATION**

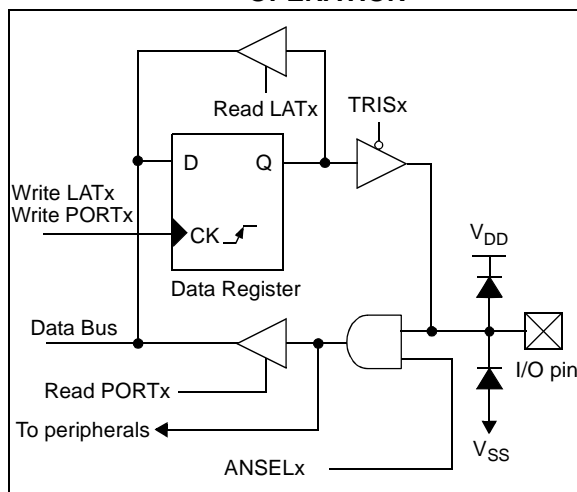

**EXAMPLE 19-1: INITIALIZING PORTA**

```

; This code example illustrates
; initializing the PORTGPA register. The
; other ports are initialized in the same
; manner.

BANKSEL PORTGPA;
CLRF   PORTGPA;Init PORTA
BANKSEL ANSELA;
CLRF   ANSELA;digital I/O
BANKSEL TRISGPA;
MOVLW  B'00011111';Set GPA<4:0> as
        ;inputs
MOVWF  TRISGPA;and set GPA<7:6> as
        ;outputs
    
```

# MCP19110/11

## 19.1 Alternate Pin Function

The Alternate Pin Function Control (APFCON) register is used to steer specific peripheral input and output functions between different pins. The APFCON register is shown in [Register 19-1](#). For the MCP19111 device, the following function can be moved between different pins:

- Frequency Synchronization Clock Input/Output

This bit has no effect on the values of any TRIS register. PORT and TRIS overrides will be routed to the correct pin. The unselected pin will be unaffected.

### REGISTER 19-1: APFCON: ALTERNATE PIN FUNCTION CONTROL REGISTER

U-0	U-0	U-0	U-0	U-0	U-0	U-0	R/W-0
—	—	—	—	—	—	—	CLKSEL
bit 7							bit 0

#### Legend:

R = Readable bit

W = Writable bit

U = Unimplemented bit, read as '0'

-n = Value at POR

'1' = Bit is set

'0' = Bit is cleared

x = Bit is unknown

bit 7-1 **Unimplemented:** Read as '0'

bit 0 **CLKSEL:** Pin Selection bit

1 = Multi-phase or multiple output clock function is on GPB5

0 = Multi-phase or multiple output clock function is on GPA1

## 19.2 PORTGPA and TRISGPA Registers

PORTGPA is an 8-bit wide, bidirectional port consisting of five CMOS I/O, two open-drain I/O, and one open-drain input-only pin. The corresponding data direction register is TRISGPA ([Register 19-3](#)). Setting a TRISGPA bit (= 1) will make the corresponding PORTGPA pin an input (i.e., disable the output driver). Clearing a TRISGPA bit (= 0) will make the corresponding PORTGPA pin an output (i.e., enables output driver). The exception is GPA5, which is input only and its TRISGPA bit will always read as '1'. [Example 19-1](#) shows how to initialize an I/O port.

Reading the PORTGPA register ([Register 19-2](#)) reads the status of the pins, whereas writing to it will write to the PORT latch. All write operations are read-modify-write operations.

The TRISGPA register ([Register 19-3](#)) controls the PORTGPA pin output drivers, even when they are being used as analog inputs. The user must ensure the bits in the TRISGPA register are maintained set when using them as analog inputs. I/O pins configured as analog input always read '0'. If the pin is configured for a digital output (either port or alternate function), the TRISGPA bit must be cleared in order for the pin to drive the signal, and a read will reflect the state of the pin.

### 19.2.1 INTERRUPT-ON-CHANGE

Each PORTGPA pin is individually configurable as an interrupt-on-change pin. Control bits IOCA<7:0> enable or disable the interrupt function for each pin. The interrupt-on-change feature is disabled on a Power-on Reset. Reference [Section 20.0 "Interrupt-On-Change"](#) for more information.

### 19.2.2 WEAK PULL-UPS

PORTGPA <3:0> and PORTGPA5 have an internal weak pull-up. PORTGPA<7:6> are special ports for the SSP module and do not have weak pull-ups. Individual control bits can enable or disable the internal weak pull-ups (see [Register 19-4](#)). The weak pull-up is automatically turned off when the port pin is configured as an output, an alternative function or on a Power-on Reset setting the RAPU bit of the OPTION register. The weak pull-up on GPA5 is enabled when configured as MCLR pin by setting bit 5 of the Configuration word, and disabled when GPA5 is an I/O. There is no software control of the MCLR pull-up.



## 19.2.3 ANSELA REGISTER

The ANSELA register ([Register 19-5](#)) is used to configure the Input mode of an I/O pin to analog. Setting the appropriate ANSELA bit high will cause all digital reads on the pin to be read as '0' and allows analog functions on the pin to operate correctly.

The state of the ANSELA bits has no effect on the digital output functions. A pin with TRISGPA clear and ANSELA set will still operate as a digital output, but the Input mode will be analog. This can cause unexpected behavior when executing read-modify-write instructions on the affected port.

**Note:** The ANSELA bits default to the Analog mode after Reset. To use any pins as digital general purpose or peripheral inputs, the corresponding ANSELA bits must be initialized to '0' by user software.

## 19.2.4 PORTGPA FUNCTIONS AND OUTPUT PRIORITIES

Each PORTGPA pin is multiplexed with other functions. The pins, their combined functions and their output priorities are shown in [Table 19-1](#). For additional information, refer to the appropriate section in this data sheet.

PORTGPA pins GPA7 and GPA4 are true open-drain pins with no connection back to  $V_{DD}$ .

When multiple outputs are enabled, the actual pin control goes to the peripheral with the highest priority.

Analog input functions, such as ADC, are not shown in the priority lists. These inputs are active when the I/O pin is set for Analog mode using the ANSELA registers. Digital output functions may control the pin when it is in Analog mode with the priority shown in [Table 19-1](#).

**TABLE 19-1: PORTGPA OUTPUT PRIORITY**

Pin Name	Function Priority <sup>(1)</sup>
GPA0	GPA0 AN0 ANALOG_TEST
GPA1	GPA1 AN1 CLKPIN
GPA2	GPA2 AN2 T0CKI INT
GPA3	GPA3 AN3
GPA4	GPA4 (open-drain input/output)
GPA5	GPA5 (open-drain data input only)
GPA6	GPA6 ICSPDAT ( <b>MCP19110 Only</b> )
GPA7	GPA7 (open-drain output) SCL ICSPCLK ( <b>MCP19110 Only</b> )

**Note 1:** Priority listed from highest to lowest.

## REGISTER 19-2: PORTGPA: PORTGPA REGISTER

R/W-x	R/W-x	R-x	R-x	R/W-x	R/W-x	R/W-x	R/W-x
GPA7	GPA6	GPA5	GPA4	GPA3	GPA2	GPA1	GPA0
bit 7							bit 0

### Legend:

R = Readable bit                      W = Writable bit                      U = Unimplemented bit, read as '0'  
 -n = Value at POR                      '1' = Bit is set                      '0' = Bit is cleared                      x = Bit is unknown

- bit 7                      **GPA7:** General Purpose Open-Drain I/O pin.
- bit 6                      **GPA6:** General Purpose I/O pin.  
 1 = Port pin is >  $V_{IH}$   
 0 = Port pin is <  $V_{IL}$
- bit 5                      **GPA5/MCLR:** General Purpose Open-Drain I/O pin.
- bit 4                      **GPA4:** General Purpose Open-Drain I/O pin.
- bit 3-0                      **GPA<3:0>:** General Purpose I/O pin.  
 1 = Port pin is >  $V_{IH}$   
 0 = Port pin is <  $V_{IL}$

# MCP19110/11

## REGISTER 19-3: TRISGPA: PORTGPA TRI-STATE REGISTER

R/W-1	R/W-1	R-1	R/W-1	R/W-1	R/W-1	R/W-1	R/W-1
TRISA7	TRISA6	TRISA5	TRISA4	TRISA3	TRISA2	TRISA1	TRISA0
bit 7							bit 0

### Legend:

R = Readable bit                      W = Writable bit                      U = Unimplemented bit, read as '0'  
 -n = Value at POR                      '1' = Bit is set                      '0' = Bit is cleared                      x = Bit is unknown

- bit 7-6            **TRISA<7:6>**: PORTGPA Tri-State Control bit  
                     1 = PORTGPA pin configured as an input (tri-stated)  
                     0 = PORTGPA pin configured as an output
- bit 5             **TRISA5**: GPA5 Port Tri-State Control bit  
                     This bit is always '1' as GPA5 is an input only
- bit 4-0           **TRISA<4:0>**: PORTGPA Tri-State Control bit  
                     1 = PORTGPA pin configured as an input (tri-stated)  
                     0 = PORTGPA pin configured as an output

## REGISTER 19-4: WPUGPA: WEAK PULL-UP PORTGPA REGISTER

U-0	U-0	R/W-1	U-0	R/W-1	R/W-1	R/W-1	R/W-1
—	—	WPUA5	—	WPUA3	WPUA2	WPUA1	WPUA0
bit 7							bit 0

### Legend:

R = Readable bit                      W = Writable bit                      U = Unimplemented bit, read as '0'  
 -n = Value at POR                      '1' = Bit is set                      '0' = Bit is cleared                      x = Bit is unknown

- bit 7-6            **Unimplemented**: Read as '0'
- bit 5             **WPUA5**: Weak Pull-up Register bit  
                     1 = Pull-up enabled.  
                     0 = Pull-up disabled.
- bit 4             **Unimplemented**: Read as '0'
- bit 3-0           **WPUA<3:0>**: Weak Pull-up Register bit  
                     1 = Pull-up enabled.  
                     0 = Pull-up disabled.

- Note 1:** The weak pull-up device is enabled only when the global  $\overline{\text{RAPU}}$  bit is enabled, the pin is in input mode (TRISGPA = 1), and the individual WPUA bit is enabled (WPUA = 1), and the pin is not configured as an analog input.
- 2:** GPA5 weak pull-up is also enabled when the pin is configured as  $\overline{\text{MCLR}}$  in Configuration word.

## REGISTER 19-5: ANSELA: ANALOG SELECT PORTGPA REGISTER

U-0	U-0	U-0	R/W-1	R/W-1	R/W-1	R/W-1	R/W-1
—	—	—	—	ANSA3	ANSA2	ANSA1	ANSA0
bit 7							bit 0

### Legend:

R = Readable bit

W = Writable bit

U = Unimplemented bit, read as '0'

-n = Value at POR

'1' = Bit is set

'0' = Bit is cleared

x = Bit is unknown

bit 7-4 **Unimplemented:** Read as '0'

bit 3-0 **ANSA<3:0>:** Analog Select PORTGPA Register bit

1 = Analog input. Pin is assigned as analog input.<sup>(1)</sup>

0 = Digital I/O. Pin is assigned to port or special function.

**Note 1:** Setting a pin to an analog input automatically disables the digital input circuitry, weak pull-ups, and interrupt-on-change if available. The corresponding TRIS bit must be set to Input mode in order to allow external control of the voltage on the pin.

**TABLE 19-2: SUMMARY OF REGISTERS ASSOCIATED WITH PORTGPA**

Name	Bit 7	Bit 6	Bit 5	Bit 4	Bit 3	Bit 2	Bit 1	Bit 0	Register on Page
ANSELA	—	—	—	—	ANSA3	ANSA2	ANSA1	ANSA0	<a href="#">115</a>
APFCON	—	—	—	—	—	—	—	CLKSEL	<a href="#">112</a>
OPTION_REG	$\overline{\text{RAPU}}$	INTEDG	T0CS	T0SE	PSA	PS2	PS1	PS0	<a href="#">77</a>
PORTGPA	GPA7	GPA6	GPA5	GPA4	GPA3	GPA2	GPA1	GPA0	<a href="#">113</a>
TRISGPA	TRISA7	TRISA6	TRISA5	TRISA4	TRISA3	TRISA2	TRISA1	TRISA0	<a href="#">114</a>
WPUGPA	—	—	WPUA5	—	WPUA3	WPUA2	WPUA1	WPUA0	<a href="#">114</a>

**Legend:** — = unimplemented locations read as '0'. Shaded cells are not used by PORTGPA.

## 19.3 PORTGPB and TRISGPB Registers

PORTGPB is an 8-bit wide, bidirectional port consisting of seven general purpose I/O ports. The corresponding data direction register is TRISGPB (Register 19-7). Setting a TRISGPB bit (= 1) will make the corresponding PORTGPB pin an input (i.e., disable the output driver). Clearing a TRISGPB bit (= 0) will make the corresponding PORTGPB pin an output (i.e., enable the output driver). Example 19-1 shows how to initialize an I/O port.

Some pins for PORTGPB are multiplexed with an alternate function for the peripheral, or a clock function. In general, when a peripheral or clock function is enabled, that pin may not be used as a general purpose I/O pin.

Reading the PORTGPB register (Register 19-6) reads the status of the pins, whereas writing to it will write to the PORT latch. All write operations are read-modify-write operations.

The TRISGPB register (Register 19-7) controls the PORTGPB pin output drivers, even when they are being used as analog inputs. The user should ensure the bits in the TRISGPB register are maintained set when using them as analog inputs. I/O pins configured as analog input always read '0'. If the pin is configured for a digital output (either port or alternate function), the TRISGPB bit must be cleared in order for the pin to drive the signal and a read will reflect the state of the pin.

### 19.3.1 INTERRUPT-ON-CHANGE

Each PORTGPB pin is individually configurable as an interrupt-on-change pin. Control bits IOCB<7:4> and IOCB<2:0> enable or disable the interrupt function for each pin. The interrupt-on-change feature is disabled on a Power-on Reset. Reference Section 20.0 "Interrupt-On-Change" for more information.

### 19.3.2 WEAK PULL-UPS

Each of the PORTGPB pins has an individually configurable internal weak pull-up. Control bits WPUB<7:4> and WPUB<2:1> enable or disable each pull-up (see Register 19-8). Each weak pull-up is automatically turned off when the port pin is configured as an output. All pull-ups are disabled on a Power-on Reset by the RAPU bit of the OPTION register.

### 19.3.3 ANSELB REGISTER

The ANSELB register (Register 19-9) is used to configure the Input mode of an I/O pin to analog. Setting the appropriate ANSELB bit high will cause all digital reads on the pin to be read as '0' and allows analog functions on the pin to operate correctly.

The state of the ANSELB bits has no effect on the digital output functions. A pin with TRISGPB clear and ANSELB set will still operate as a digital output, but the

Input mode will be analog. This can cause unexpected behavior when executing read-modify-write instructions on the affected port.

**Note:** The ANSELB bits default to the Analog mode after Reset. To use any pins as digital general purpose or peripheral inputs, the corresponding ANSELB bits must be initialized to '0' by the user's software.

### 19.3.4 PORTGPB FUNCTIONS AND OUTPUT PRIORITIES

Each PORTGPB pin is multiplexed with other functions. The pins, their combined functions and their output priorities are shown in Table 19-3. For additional information, refer to the appropriate section in this data sheet.

PORTGPB pin GPB0 is a true open-drain pin with no connection back to  $V_{DD}$ .

When multiple outputs are enabled, the actual pin control goes to the peripheral with the highest priority.

Analog input functions, such as ADC, and some digital input functions are not included in the list below. These inputs are active when the I/O pin is set for Analog mode using the ANSELB registers. Digital output functions may control the pin when it is in Analog mode, with the priority shown in Table 19-3.

**TABLE 19-3: PORTGPB OUTPUT PRIORITY**

Pin Name	Function Priority <sup>(1)</sup>
GPB0	GPB0 (open-drain input/output) SDA
GPB1	GPB1 AN4 EAPIN
GPB2	GPB2 AN5
GPB4	GPB4 AN6 ICSPDAT/ICDDAT (MCP19111 Only)
GPB5	GPB5 AN7 ICSPCLK/ICDCLK (MCP19111 Only) ALT_CLKPIN (MCP19111 Only)
GPB6	GPB6
GPB7	GPB7

**Note 1:** Priority listed from highest to lowest.

## REGISTER 19-6: PORTGPB: PORTGPB REGISTER

R/W-x	R/W-x	R/W-x	R/W-x	U-x	R/W-x	R/W-x	R/W-x
GPB7 <sup>(1)</sup>	GPB6 <sup>(1)</sup>	GPB5 <sup>(1)</sup>	GPB4 <sup>(1)</sup>	—	GPB2	GPB1	GPB0
bit 7							bit 0

### Legend:

R = Readable bit  
-n = Value at POR

W = Writable bit  
'1' = Bit is set

U = Unimplemented bit, read as '0'  
'0' = Bit is cleared  
x = Bit is unknown

- bit 7-4      **GPB<7:4>**: General Purpose I/O Pin bit  
                  1 = Port pin is > V<sub>IH</sub>  
                  0 = Port pin is < V<sub>IL</sub>
- bit 3      **Unimplemented**: Read as '0'
- bit 2-0      **GPB<2:0>**: General Purpose I/O Pin bit  
                  1 = Port pin is > V<sub>IH</sub>  
                  0 = Port pin is < V<sub>IL</sub>

**Note 1:** Not implemented on MCP19110.

## REGISTER 19-7: TRISGPB: PORTGPB TRI-STATE REGISTER

R/W-1	R/W-1	R/W-1	R/W-1	U-1	R/W-1	R/W-1	R/W-1
TRISB7 <sup>(1)</sup>	TRISB6 <sup>(1)</sup>	TRISB5 <sup>(1)</sup>	TRISB4 <sup>(1)</sup>	—	TRISB2	TRISB1	TRISB0
bit 7							bit 0

### Legend:

R = Readable bit  
-n = Value at POR

W = Writable bit  
'1' = Bit is set

U = Unimplemented bit, read as '0'  
'0' = Bit is cleared  
x = Bit is unknown

- bit 7-4      **TRISB<7:4>**: PORTGPB Tri-State Control bit  
                  1 = PORTGPB pin configured as an input (tri-stated)  
                  0 = PORTGPB pin configured as an output
- bit 3      **Unimplemented**: Read as '1'
- bit 2-0      **TRISB<2:0>**: PORTGPB Tri-State Control bit  
                  1 = PORTGPB pin configured as an input (tri-stated)  
                  0 = PORTGPB pin configured as an output

**Note 1:** Not implemented on MCP19110.

# MCP19110/11

## REGISTER 19-8: WPUGPB: WEAK PULL-UP PORTGPB REGISTER

R/W-1	R/W-1	R/W-1	R/W-1	U-0	R/W-1	R/W-1	U-0
WPUB7 <sup>(2)</sup>	WPUB6 <sup>(2)</sup>	WPUB5 <sup>(2)</sup>	WPUB4 <sup>(2)</sup>	—	WPUB2	WPUB1	—
bit 7							bit 0

### Legend:

R = Readable bit                      W = Writable bit                      U = Unimplemented bit, read as '0'  
 -n = Value at POR                      '1' = Bit is set                      '0' = Bit is cleared                      x = Bit is unknown

bit 7-4                      **WPUB<7:4>**: Weak Pull-up Register bit

1 = Pull-up enabled  
 0 = Pull-up disabled

bit 3                      **Unimplemented**: Read as '0'

bit 2-1                      **WPUB<2:1>**: Weak Pull-up Register bit

1 = Pull-up enabled  
 0 = Pull-up disabled

bit 0                      **Unimplemented**: Read as '0'

**Note 1:** The weak pull-up device is enabled only when the global  $\overline{\text{RAPU}}$  bit is enabled, the pin is in Input mode (TRISGPA = 1), the individual WPUB bit is enabled (WPUB = 1), and the pin is not configured as an analog input.

**2:** Not implemented on MCP19110.

## REGISTER 19-9: ANSELB: ANALOG SELECT PORTGPB REGISTER

U-0	U-0	R/W-1	R/W-1	U-0	R/W-1	R/W-1	U-0
—	—	ANSB5 <sup>(2)</sup>	ANSB4 <sup>(2)</sup>	—	ANSB2	ANSB1	—
bit 7							bit 0

### Legend:

R = Readable bit                      W = Writable bit                      U = Unimplemented bit, read as '0'  
 -n = Value at POR                      '1' = Bit is set                      '0' = Bit is cleared                      x = Bit is unknown

bit 7-6                      **Unimplemented**: Read as '0'

bit 5-4                      **ANSB<5:4>**: Analog Select PORTGPB Register bit

1 = Analog input. Pin is assigned as analog input<sup>(1)</sup>.  
 0 = Digital I/O. Pin is assigned to port or special function.

bit 3                      **Unimplemented**: Read as '0'

bit 2-1                      **ANSB<2:1>**: Analog Select PORTGPB Register bit

1 = Analog input. Pin is assigned as analog input<sup>(1)</sup>.  
 0 = Digital I/O. Pin is assigned to port or special function.

bit 0                      **Unimplemented**: Read as '0'

**Note 1:** Setting a pin to an analog input automatically disables the digital input circuitry, weak pull-ups and interrupt-on-change if available. The corresponding TRIS bit must be set to Input mode in order to allow external control of the voltage on the pin.

**2:** Not implemented on MCP19110.

**TABLE 19-4: SUMMARY OF REGISTERS ASSOCIATED WITH PORTGPB**

Name	Bit 7	Bit 6	Bit 5	Bit 4	Bit 3	Bit 2	Bit 1	Bit 0	Register on Page
ANSELB	—	—	ANSB5	ANSB4	—	ANSB2	ANSB1	—	<a href="#">118</a>
APFCON	—	—	—	—	—	—	—	CLKSEL	<a href="#">112</a>
OPTION_REG	$\overline{\text{RAPU}}$	INTEDG	T0CS	T0SE	PSA	PS2	PS1	PS0	<a href="#">77</a>
PORTGPB	GPB7	GPB6	GPB5	GPB4	—	GPB2	GPB1	GPB0	<a href="#">117</a>
TRISGPB	TRISB7	TRISB6	TRISB5	TRISB4	—	TRISB2	TRISB1	TRISB0	<a href="#">117</a>
WPUGPB	WPUB7	WPUB6	WPUB5	WPUB4	—	WPUB2	WPUB1	—	<a href="#">118</a>

**Legend:** — = unimplemented locations read as '0'. Shaded cells are not used by PORTGPB.

# MCP19110/11

---

NOTES:



## 20.0 INTERRUPT-ON-CHANGE

Each PORTGPA and PORTGPB pin is individually configurable as an interrupt-on-change pin. Control bits IOCA and IOCB enable or disable the interrupt function for each pin. Refer to [Register 20-1](#) and [Register 20-2](#). The interrupt-on-change is disabled on a Power-on Reset.

The interrupt-on-change on GPA5 is disabled when configured as MCLR pin in the Configuration Word.

For enabled interrupt-on-change pins, the values are compared with the old value latched on the last read of PORTGPA or PORTGPB. The mismatched outputs of the last read of all the PORTGPA and PORTGPB pins are OR'ed together to set the Interrupt-on-Change Interrupt Flag bit (IOCF) in the INTCON register ([Register 15-1](#)).

### 20.1 Enabling the Module

To allow individual port pins to generate an interrupt, the IOCIE bit of the INTCON register must be set. If the IOCIE bit is disabled, the edge detection on the pin will still occur, but an interrupt will not be generated.

### 20.2 Individual Pin Configuration

To enable a pin to detect an interrupt-on-change, the associated IOCAx or IOCBx bit of the IOCA or IOCB register is set.

## 20.3 Clearing Interrupt Flags

The user, in the Interrupt Service Routine, clears the interrupt by:

- a) Any read of PORTGPA or PORTGPB AND Clear flag bit IOCF. This will end the mismatch condition;  
OR
- b) Any write of PORTGPA or PORTGPB AND Clear flag bit IOCF will end the mismatch condition;

A mismatch condition will continue to set flag bit IOCF. Reading PORTGPA or PORTGPB will end the mismatch condition and allow flag bit IOCF to be cleared. The latch holding the last read value is not affected by a MCLR Reset. After this Reset, the IOCF flag will continue to be set if a mismatch is present.

<b>Note:</b> If a change on the I/O pin should occur when any PORTGPA or PORTGPB operation is being executed, then the IOCF interrupt flag may not get set.
---

### 20.4 Operation in Sleep

The interrupt-on-change interrupt sequence will wake the device from Sleep mode, if the IOCE bit is set.

# MCP19110/11

## 20.5 Interrupt-On-Change Registers

**REGISTER 20-1: IOCA: INTERRUPT-ON-CHANGE PORTGPA REGISTER**

R/W-0	R/W-0	R/W-0	R/W-0	R/W-0	R/W-0	R/W-0	R/W-0
IOCA7	IOCA6	IOCA5	IOCA4	IOCA3	IOCA2	IOCA1	IOCA0
bit 7							bit 0

**Legend:**

R = Readable bit                      W = Writable bit                      U = Unimplemented bit, read as '0'  
 -n = Value at POR                      '1' = Bit is set                      '0' = Bit is cleared                      x = Bit is unknown

bit 7-6            **IOCA<7:6>**: Interrupt-on-Change PORTGPA Register bits.

1 = Interrupt-on-change enabled on the pin.  
 0 = Interrupt-on-change disabled on the pin.

bit 5              **IOCA<5>**: Interrupt-on-Change PORTGPA Register bits<sup>(1)</sup>.

1 = Interrupt-on-change enabled on the pin.  
 0 = Interrupt-on-change disabled on the pin.

bit 4-0            **IOCA<4:0>**: Interrupt-on-Change PORTGPA Register bits.

1 = Interrupt-on-change enabled on the pin.  
 0 = Interrupt-on-change disabled on the pin.

**Note 1:** The Interrupt-on-change on GPA5 is disabled if GPA5 is configured as  $\overline{\text{MCLR}}$ .

**REGISTER 20-2: IOCB: INTERRUPT-ON-CHANGE PORTGPB REGISTER**

R/W-0	R/W-0	R/W-0	R/W-0	U-0	R/W-0	R/W-0	R/W-0
IOCB7 <sup>(1)</sup>	IOCB6 <sup>(1)</sup>	IOCB5 <sup>(1)</sup>	IOCB4 <sup>(1)</sup>	—	IOCB2	IOCB1	IOCB0
bit 7							bit 0

**Legend:**

R = Readable bit                      W = Writable bit                      U = Unimplemented bit, read as '0'  
 -n = Value at POR                      '1' = Bit is set                      '0' = Bit is cleared                      x = Bit is unknown

bit 7-4            **IOCB<7:4>**: Interrupt-on-Change PORTGPB Register bits.

1 = Interrupt-on-change enabled on the pin.  
 0 = Interrupt-on-change disabled on the pin.

bit 3              **Unimplemented:** Read as '0'

bit 2-0            **IOCB<2:0>**: Interrupt-on-Change PORTGPB Register bits.

1 = Interrupt-on-change enabled on the pin.  
 0 = Interrupt-on-change disabled on the pin.

**Note 1:** Not implemented on MCP19111.

**TABLE 20-1: SUMMARY OF REGISTERS ASSOCIATED WITH INTERRUPT-ON-CHANGE**

Name	Bit 7	Bit 6	Bit 5	Bit 4	Bit 3	Bit 2	Bit 1	Bit 0	Register on Page
ANSELA	—	—	—	—	ANSA3	ANSA2	ANSA1	ANSA0	115
ANSELB	—	—	ANSB5	ANSB4	—	ANSB2	ANSB1	—	118
INTCON	GIE	PEIE	T0IE	INTE	IOCE	T0IF	INTF	IOCF	96
IOCA	IOCA7	IOCA6	IOCA5	IOCA4	IOCA3	IOCA2	IOCA1	IOCA0	122
IOCB	IOCB7	IOCB6	IOCB5	IOCB4	—	IOCB2	IOCB1	IOCB0	122
TRISGPA	TRISA7	TRISA6	TRISA5	TRISA4	TRISA3	TRISA2	TRISA1	TRISA0	114
TRISGPB	TRISB7	TRISB6	TRISB5	TRISB4	—	TRISB2	TRISB1	TRISB0	117

**Legend:** — = unimplemented locations read as '0'. Shaded cells are not used by interrupt-on-change.

## 21.0 INTERNAL TEMPERATURE INDICATOR MODULE

The MCP19110/11 is equipped with a temperature circuit designed to measure the operating temperature of the silicon die. The circuit's range of the operating temperature falls between -40°C and +125°C. The output is a voltage that is proportional to the device temperature. The output of the temperature indicator is internally connected to the device ADC.

### 21.1 Circuit Operation

The TMPSEN bit in the ABECON register, [Register 6-15](#), is set to enable the internal temperature measurement circuit. The MCP19110/11 overtemperature shutdown feature is NOT controlled by this bit.

### 21.2 Temperature Output

The output of the circuit is measured using the internal analog-to-digital converter. Channel 10 is reserved for the temperature circuit output. Refer to [Section 22.0 "Analog-to-Digital Converter \(ADC\) Module"](#) for detailed information.

The temperature of the silicon die can be calculated by the ADC measurement by using [Equation 21-1](#).

#### EQUATION 21-1: SILICON DIE TEMPERATURE

$$TEMP\_DIE = \frac{ADC\ READING - 1.75}{13.3mV/^{\circ}C}$$

**FIGURE 21-1: TEMPERATURE CIRCUIT DIAGRAM**

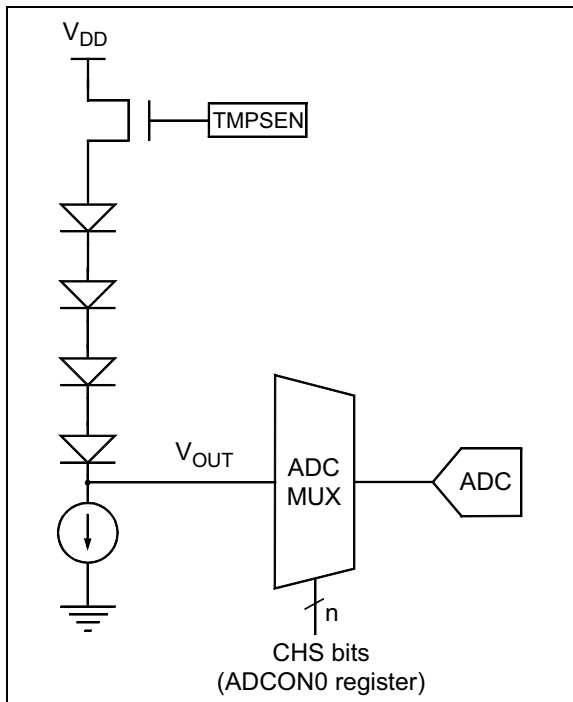

# MCP19110/11

---

NOTES:

## 22.0 ANALOG-TO-DIGITAL CONVERTER (ADC) MODULE

The Analog-to-Digital Converter (ADC) allows conversion of an analog input signal to a 10-bit binary representation of that signal. This device uses analog inputs, which are multiplexed into a single sample and hold circuit. The output of the sample and hold is connected to the input of the converter. The converter generates a 10-bit binary result via successive approximation and stores the right justified conversion result into the ADC result registers (ADRESH:ADRESL register pair). [Figure 22-1](#) shows the block diagram of the ADC.

The internal band gap supplies the voltage reference to the ADC.

The ADC can generate an interrupt upon completion of a conversion. This interrupt can be used to wake-up the device from Sleep.

**FIGURE 22-1: ADC BLOCK DIAGRAM**

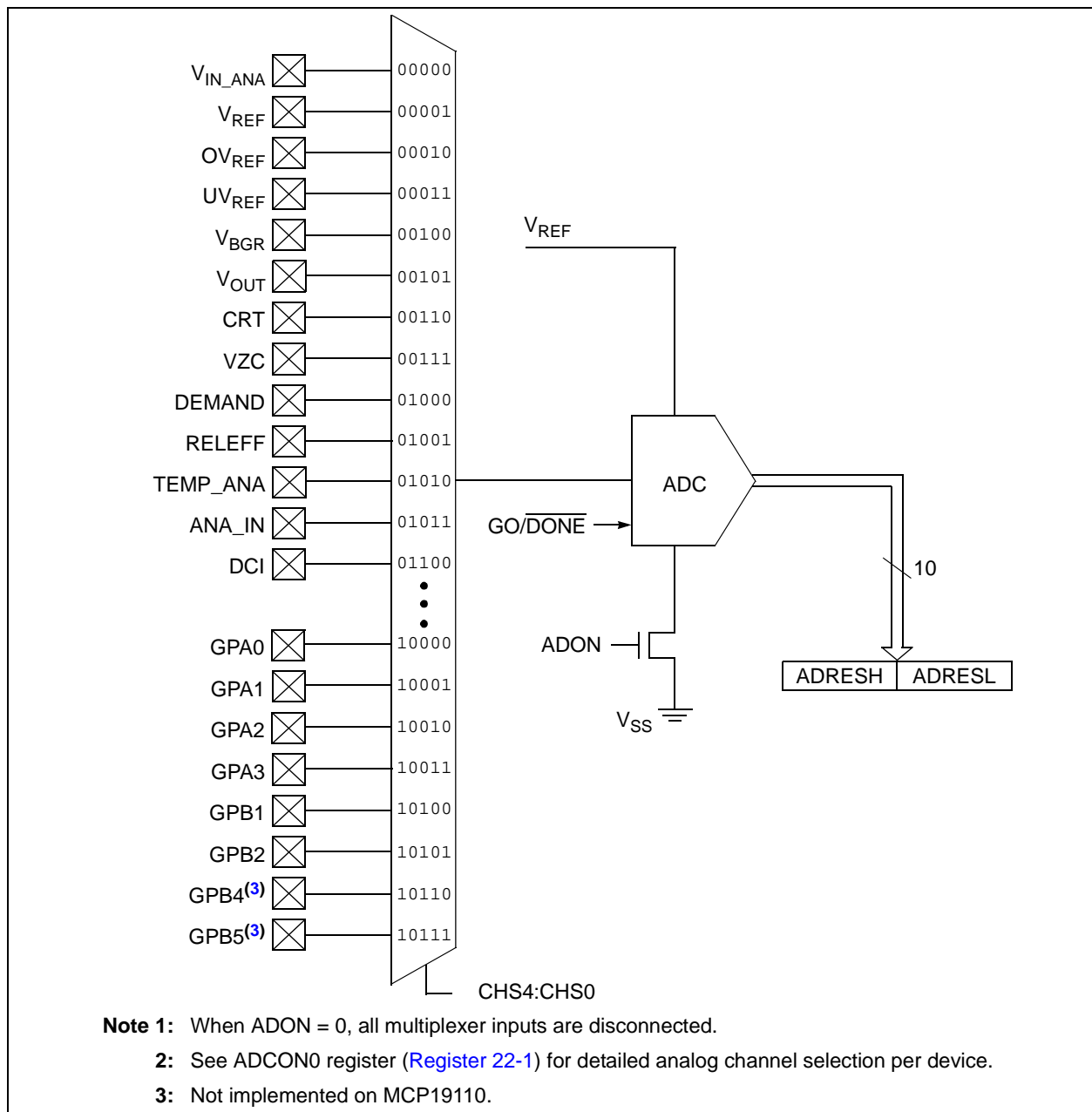

# MCP19110/11

## 22.1 ADC Configuration

When configuring and using the ADC, the following functions must be considered:

- Port configuration
- Channel selection
- ADC conversion clock source
- Interrupt control
- Result formatting

### 22.1.1 PORT CONFIGURATION

The ADC can be used to convert both analog and digital signals. When converting analog signals, the I/O pin should be configured for analog by setting the associated TRIS and ANSEL bits. Refer to [Section 19.0 “I/O Ports”](#) for more information.

**Note:** Analog voltages on any pin that is defined as a digital input may cause the input buffer to conduct excess current.

### 22.1.2 CHANNEL SELECTION

There are up to 19 channel selections available on the MCP19110 and 21 channel selections available on the MCP19111:

- AN<6:0> pins
- VIN: 1/5 of the input voltage ( $V_{IN}$ )
- VREGREF:  $V_{OUT}$  reference voltage
- OV\_REF: reference for OV comparator
- UV\_REF: reference for UV comparator
- VBGR: band gap reference
- VOUT: output voltage
- CRT: voltage proportional to the AC inductor current
- VZC: an internal ground, Voltage for Zero Current
- DEMAND: input to slope compensation circuitry
- RELEFF: relative efficient measurement channel
- TMP\_ANA: voltage proportional to silicon die temperature
- ANA\_IN: for a multi-phase slave, error amplifier signal received from master
- DCI: DC inductor valley current

The CHS<4:0> bits of the ADCON0 register determine which channel is connected to the sample and hold circuit.

When changing channels, a delay is required before starting the next conversion. Refer to [Section 22.2 “ADC Operation”](#) for more information.

### 22.1.3 ADC CONVERSION CLOCK

The source of the conversion clock is software selectable via the ADCS bits of the ADCON1 register. There are five possible clock options:

- $F_{OSC}/8$
- $F_{OSC}/16$
- $F_{OSC}/32$
- $F_{OSC}/64$
- $F_{RC}$  (clock derived from internal oscillator with a divisor of 16)

The time to complete one bit conversion is defined as  $T_{AD}$ . One full 10-bit conversion requires 11  $T_{AD}$  periods as shown in [Figure 22-2](#).

For a correct conversion, the appropriate  $T_{AD}$  specification must be met. Refer to the A/D conversion requirements in [Section 5.0 “Digital Electrical Characteristics”](#) for more information. [Table 22-1](#) gives examples of appropriate ADC clock selections.

**Note:** Unless using the  $F_{RC}$ , any changes in the system clock frequency will change the ADC clock frequency, which may adversely affect the ADC result.

**TABLE 22-1: ADC CLOCK PERIOD ( $T_{AD}$ ) VS. DEVICE OPERATING FREQUENCIES**

ADC Clock Period ( $T_{AD}$ )		Device Frequency ( $F_{OSC}$ )
ADC Clock Source	ADCS<2:0>	8 MHz
$F_{OSC}/8$	001	1.0 $\mu s$ <sup>(2)</sup>
$F_{OSC}/16$	101	2.0 $\mu s$
$F_{OSC}/32$	010	4.0 $\mu s$
$F_{OSC}/64$	110	8.0 $\mu s$ <sup>(3)</sup>
$F_{RC}$	x11	2.0 – 6.0 $\mu s$ <sup>(1,4)</sup>

**Legend:** Shaded cells are outside of recommended range.

- Note 1:** The  $F_{RC}$  source has a typical  $T_{AD}$  time of 4  $\mu s$  for  $V_{DD} > 3.0V$ .
- Note 2:** These values violate the minimum required  $T_{AD}$  time.
- Note 3:** For faster conversion times, the selection of another clock source is recommended.
- Note 4:** The  $F_{RC}$  clock source is only recommended if the conversion will be preformed during Sleep.

**FIGURE 22-2: ANALOG-TO-DIGITAL CONVERSION  $T_{AD}$  CYCLES**

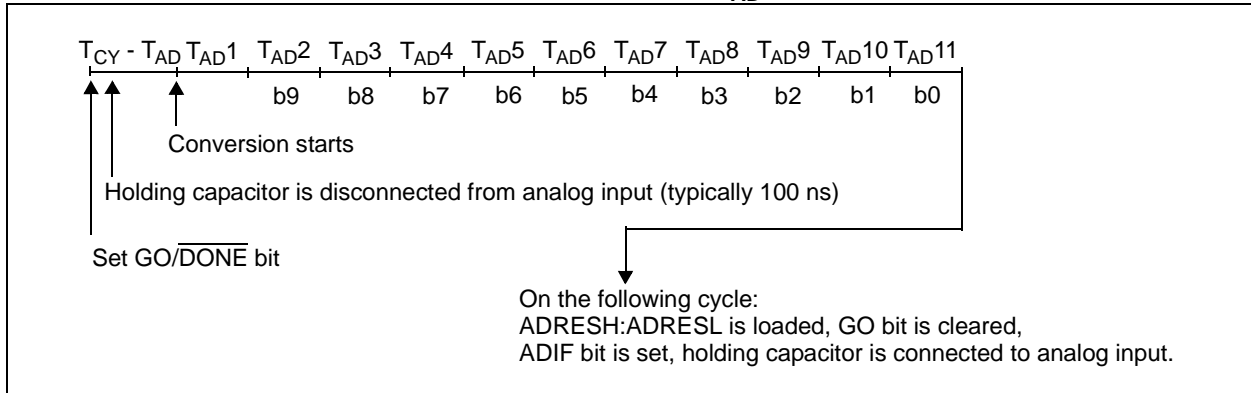

### 22.1.4 INTERRUPTS

The ADC module allows for the ability to generate an interrupt upon completion of an Analog-to-Digital conversion. The ADC Interrupt Flag is the ADIF bit in the PIR1 register. The ADC Interrupt Enable is the ADIE bit in the PIE1 register. The ADIF bit must be cleared in software.

**Note 1:** The ADIF bit is set at the completion of every conversion, regardless of whether or not the ADC interrupt is enabled.

**2:** The ADC operates during Sleep-only when the  $F_{RC}$  oscillator is selected.

This interrupt can be generated while the device is operating, or while in Sleep. If the device is in Sleep, the interrupt will wake-up the device. Upon waking from Sleep, the next instruction following the `SLEEP` instruction is always executed. If the user is attempting to wake-up from Sleep and resume in-line code execution, the GIE and PEIE bits of the INTCON register must be disabled. If the GIE and PEIE bits of the INTCON register are enabled, execution will switch to the Interrupt Service Routine.

### 22.1.5 RESULT FORMATTING

The 10-bit A/D conversion result is supplied in right justified format only.

Figure 22-3 shows the output format.

**FIGURE 22-3: 10-BIT A/D RESULT FORMAT**

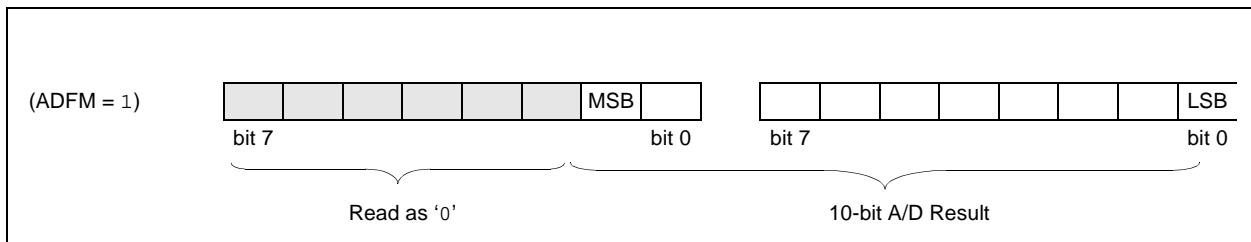

## 22.2 ADC Operation

### 22.2.1 STARTING A CONVERSION

To enable the ADC module, the ADON bit of the ADCON0 register must be set to a '1'. Setting the GO/DONE bit of the ADCON0 register to a '1' will start the Analog-to-Digital conversion.

**Note:** The GO/DONE bit should not be set in the same instruction that turns on the ADC. Refer to [Section 22.2.5 “A/D Conversion Procedure”](#).

### 22.2.2 COMPLETION OF A CONVERSION

When the conversion is complete, the ADC module will:

- Clear the GO/DONE bit
- Set the ADIF Interrupt Flag bit
- Update the ADRESH:ADRESL registers with new conversion result

### 22.2.3 TERMINATING A CONVERSION

If a conversion must be terminated before completion, the GO/DONE bit can be cleared in software. The ADRESH:ADRESL registers will not be updated with the partially complete Analog-to-Digital conversion sample. Instead, the ADRESH:ADRESL register pair will retain the value of the previous conversion. Additionally, a two T<sub>AD</sub> delay is required before another acquisition can be initiated. Following the delay, an input acquisition is automatically started on the selected channel.

**Note:** A device Reset forces all registers to their Reset state. Thus, the ADC module is turned off and any pending conversion is terminated.

### 22.2.4 ADC OPERATION DURING SLEEP

The ADC module can operate during Sleep. This requires the ADC clock source to be set to the F<sub>RC</sub> option. When the F<sub>RC</sub> clock source is selected, the ADC waits one additional instruction before starting the conversion. This allows the SLEEP instruction to be executed, which can reduce system noise during the conversion. If the ADC interrupt is enabled, the device will wake-up from Sleep when the conversion completes. If the ADC interrupt is disabled, the ADC module is turned off after the conversion completes, although the ADON bit remains set.

When the ADC clock source is something other than F<sub>RC</sub>, a SLEEP instruction causes the present conversion to be aborted and the ADC module is turned off, although the ADON bit remains set.

### 22.2.5 A/D CONVERSION PROCEDURE

This is an example procedure for using the ADC to perform an Analog-to-Digital conversion:

1. Configure Port:
  - Disable pin output driver (Refer to the TRIS register)
  - Configure pin as analog (Refer to the ANSEL register)
2. Configure the ADC module:
  - Select ADC conversion clock
  - Select ADC input channel
  - Turn on ADC module
3. Configure ADC interrupt (optional):
  - Clear ADC interrupt flag
  - Enable ADC interrupt
  - Enable peripheral interrupt
  - Enable global interrupt<sup>(1)</sup>
4. Wait the required acquisition time<sup>(2)</sup>.
5. Start conversion by setting the GO/DONE bit.
6. Wait for ADC conversion to complete by one of the following:
  - Polling the GO/DONE bit
  - Waiting for the ADC interrupt (interrupts enabled)
7. Read ADC Result.
8. Clear the ADC interrupt flag (required if interrupt is enabled).

**Note 1:** The global interrupt can be disabled if the user is attempting to wake-up from Sleep and resume in-line code execution.

**2:** Refer to [Section 22.4 “A/D Acquisition Requirements”](#).

#### EXAMPLE 22-1: A/D CONVERSION

```

;This code block configures the ADC
;for polling, Frc clock and AN0 input.
;
;Conversion start & polling for completion ;
are included.
;
BANKSEL  ADCON1      ;
MOVLW   B'01110000' ;Frc clock
MOVWF   ADCON1      ;
BANKSEL  TRISGPA    ;
BSF     TRISGPA,0   ;Set GPA0 to input
BANKSEL  ANSELA     ;
BSF     ANSELA,0    ;Set GPA0 to analog
BANKSEL  ADCON0     ;
MOVLW   B'01000001' ;Select channel AN0
MOVWF   ADCON0     ;Turn ADC On
CALL    SampleTime  ;Acquisition delay
BSF     ADCON0,1    ;Start conversion
BTFSC   ADCON0,1    ;Is conversion done?
GOTO    $-1         ;No, test again
BANKSEL  ADRESH     ;
MOV     ADRESH,W    ;Read upper 2 bits
MOVWF  RESULTHI     ;store in GPR space
BANKSEL  ADRESL     ;
MOV     ADRESL,W    ;Read lower 8 bits
MOVWF  RESULTLO     ;Store in GPR space
    
```



## 22.3 ADC Register Definitions

The following registers are used to control the operation of the ADC:

### REGISTER 22-1: ADCON0: A/D CONTROL REGISTER 0

U-0	R/W-0	R/W-0	R/W-0	R/W-0	R/W-0	R/W-0	R/W-0
—	CHS4	CHS3	CHS2	CHS1	CHS0	GO/DONE	ADON
bit 7							bit 0

#### Legend:

R = Readable bit	W = Writable bit	U = Unimplemented bit, read as '0'
-n = Value at POR	'1' = Bit is set	'0' = Bit is cleared
		x = Bit is unknown

bit 7 **Unimplemented:** Read as '0'

bit 6-2 **CHS<4:0>:** Analog Channel Select bits

00000 = VIN\_ANA (analog voltage proportional to  $V_{IN}$ )  
 00001 = VREGREF (reference voltage for  $V_{REG}$  output)  
 00010 = OV\_REF (reference for overvoltage comparator)  
 00011 = UV\_REF (reference for undervoltage comparator)  
 00100 = VBGR (band gap reference)  
 00101 = INT\_VREG (internal version of the  $V_{REG}$  load voltage)  
 00110 = CRT (voltage proportional to the current in the inductor)  
 00111 = VZC (an internal ground, Voltage for Zero Current)  
 01000 = DEMAND (input to current loop, output of demand mux)  
 01001 = RELEFF (analog voltage proportional to duty cycle)  
 01010 = TMP\_ANA (analog voltage proportional to temperature)  
 01011 = ANA\_IN (demanded current from the remote master)  
 01100 = DCI (dc inductor valley current)  
 01101 = Unimplemented  
 01110 = Unimplemented  
 01111 = Unimplemented  
 10000 = GPA0 (i.e. ADDR1)  
 10001 = GPA1 (i.e. ADDR0)  
 10010 = GPA2 (i.e. Temperature Sensor Input)  
 10011 = GPA3 (i.e. Tracking Voltage)  
 10100 = GPB1  
 10101 = GPB2  
 10110 = GPB4<sup>(1)</sup>  
 10111 = GPB5<sup>(1)</sup>  
 11000 = Unimplemented  
 11001 = Unimplemented  
 11011 = Unimplemented  
 11100 = Unimplemented  
 11101 = Unimplemented  
 11110 = Unimplemented  
 11111 = Unimplemented

bit 1 **GO/DONE:** A/D Conversion Status bit

1 = A/D conversion cycle in progress. Setting this bit starts an A/D conversion cycle.  
 This bit is automatically cleared by hardware when the A/D conversion has completed.  
 0 = A/D conversion completed/not in progress

bit 0 **ADON:** ADC Enable bit

1 = ADC is enabled  
 0 = ADC is disabled and consumes no operating current

**Note 1:** Not implemented on MCP19110.

# MCP19110/11

## REGISTER 22-2: ADCON1: A/D CONTROL REGISTER 1

U-0	R/W-0	R/W-0	R/W-0	U-0	U-0	U-0	U-0
—	ADCS2	ADCS1	ADCS0	—	—	—	—
bit 7							bit 0

### Legend:

R = Readable bit                      P = Programmable bit                      U = Unimplemented bit, read as '0'  
 -n = Value at POR                      '1' = Bit is set                      '0' = Bit is cleared                      x = Bit is unknown

bit 7                      **Unimplemented:** Read as '0'  
 bit 6-4                      **ADCS<2:0>:** A/D Conversion Clock Select bits  
                                     000 = Reserved  
                                     001 =  $F_{OSC}/8$   
                                     010 =  $F_{OSC}/32$   
                                     x11 =  $F_{RC}$  (clock derived from internal oscillator with a divisor of 16)  
                                     100 = Reserved  
                                     101 =  $F_{OSC}/16$   
                                     110 =  $F_{OSC}/64$   
 bit 3-0                      **Unimplemented:** Read as '0'

## REGISTER 22-3: ADRESH: ADC RESULT REGISTER HIGH (ADRESH)

U-0	U-0	U-0	U-0	U-0	U-0	R-x	R-x
—	—	—	—	—	—	ADRES9	ADRES8
bit 7							bit 0

### Legend:

R = Readable bit                      W = Writable bit                      U = Unimplemented bit, read as '0'  
 -n = Value at POR                      '1' = Bit is set                      '0' = Bit is cleared                      x = Bit is unknown

bit 7-2                      **Unimplemented:** Read as '0'  
 bit 1-0                      **ADRES<9:8>:** Most Significant A/D Results

## REGISTER 22-4: ADRESL: ADC RESULT REGISTER LOW (ADRESL)

R-x	R-x	R-x	R-x	R-x	R-x	R-x	R-x
ADRES7	ADRES6	ADRES5	ADRES4	ADRES3	ADRES2	ADRES1	ADRES0
bit 7							bit 0

### Legend:

R = Readable bit                      W = Writable bit                      U = Unimplemented bit, read as '0'  
 -n = Value at POR                      '1' = Bit is set                      '0' = Bit is cleared                      x = Bit is unknown

bit 7-0                      **ADRES<7:0>:** Least Significant A/D results

## 22.4 A/D Acquisition Requirements

For the ADC to meet its specified accuracy, the charge holding capacitor ( $C_{HOLD}$ ) must be allowed to fully charge to the input channel voltage level. The Analog Input model is shown in [Figure 22-4](#). The source impedance ( $R_S$ ) and the internal sampling switch ( $R_{SS}$ ) impedance directly affect the time required to charge the capacitor  $C_{HOLD}$ . The sampling switch ( $R_{SS}$ ) impedance varies over the device voltage ( $V_{DD}$ ), refer to [Figure 22-4](#).

The maximum recommended impedance for analog sources is 10 k $\Omega$ . As the source impedance is decreased, the acquisition time may be decreased. After the analog input channel is selected (or changed), an A/D acquisition must be done before the conversion can be started. To calculate the minimum acquisition time, [Equation 22-1](#) may be used. This equation assumes that 1/2 LSB error is used (1,024 steps for the ADC). The 1/2 LSB error is the maximum error allowed for the ADC to meet its specified resolution.

### EQUATION 22-1: ACQUISITION TIME EXAMPLE

**Assumptions:** Temperature = +50°C and external impedance of 10 k $\Omega$  5.0V  $V_{DD}$

$$\begin{aligned} T_{ACQ} &= \text{Amplifier Settling Time} + \text{Hold Capacitor Charging Time} + \text{Temperature Coefficient} \\ &= T_{AMP} + T_C + T_{COFF} \\ &= 2 \mu s + T_C + [(Temperature - 25^\circ C)(0.05 \mu s/^\circ C)] \end{aligned}$$

The value for  $T_C$  can be approximated with the following equations:

$$V_{APPLIED} \left( 1 - \frac{1}{(2^n + 1) - 1} \right) = V_{CHOLD} \quad ;[1] V_{CHOLD} \text{ charged to within } 1/2 \text{ lsb}$$

$$V_{APPLIED} \left( 1 - e^{-\frac{T_C}{RC}} \right) = V_{CHOLD} \quad ;[2] V_{CHOLD} \text{ charge response to } V_{APPLIED}$$

$$V_{APPLIED} \left( 1 - e^{-\frac{T_C}{RC}} \right) = V_{APPLIED} \left( 1 - \frac{1}{(2^n + 1) - 1} \right) \quad ;\text{combining [1] and [2]}$$

**Note:** Where  $n$  = number of bits of the ADC.

Solving for  $T_C$ :

$$\begin{aligned} T_C &= -C_{HOLD}(R_{IC} + R_{SS} + R_S) \ln(1/2047) \\ &= -10 \text{ pF}(1 \text{ k}\Omega + 7 \text{ k}\Omega + 10 \text{ k}\Omega) \ln(0.0004885) \\ &= 1.37 \mu s \end{aligned}$$

Therefore:

$$\begin{aligned} T_{ACQ} &= 2 \mu s + 1.37 \mu s + [(50^\circ C - 25^\circ C)(0.05 \mu s/^\circ C)] \\ &= 4.67 \mu s \end{aligned}$$

**Note 1:** The charge holding capacitor ( $C_{HOLD}$ ) is not discharged after each conversion.

**2:** The maximum recommended impedance for analog sources is 10 k $\Omega$ . This is required to meet the pin leakage specification.

# MCP19110/11

**FIGURE 22-4: ANALOG INPUT MODEL**

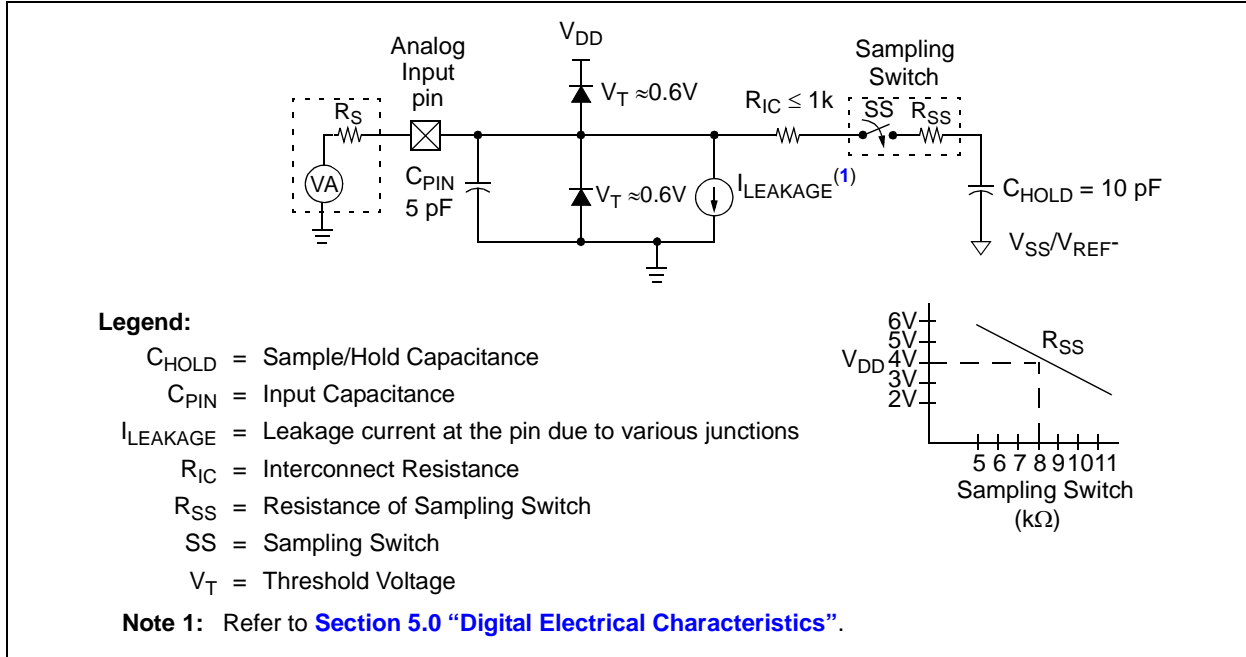

**FIGURE 22-5: ADC TRANSFER FUNCTION**

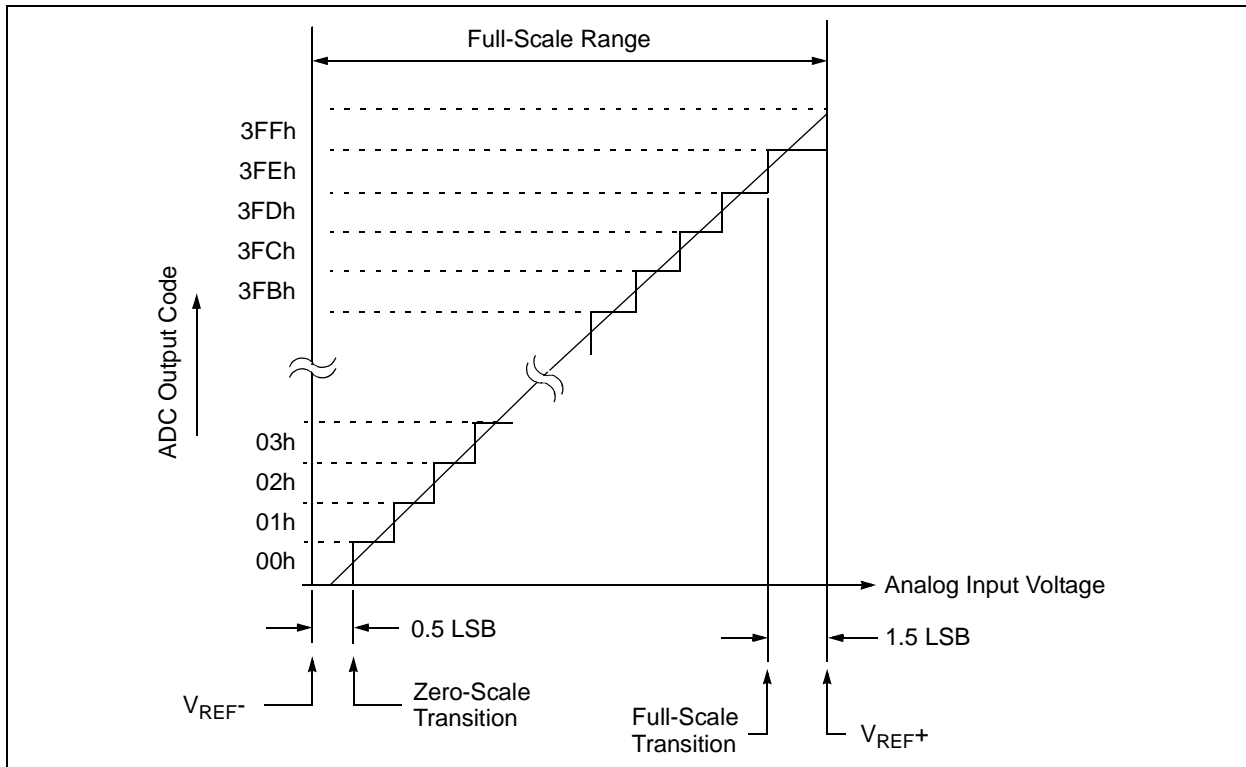

**TABLE 22-2: SUMMARY OF REGISTERS ASSOCIATED WITH ADC**

Name	Bit 7	Bit 6	Bit 5	Bit 4	Bit 3	Bit 2	Bit 1	Bit 0	Register on Page
ADCON0	—	CHS4	CHS3	CHS2	CHS1	CHS0	GO/DONE	ADON	<a href="#">129</a>
ADCON1	—	ADCS2	ADCS1	ADCS0	—	—	—	—	<a href="#">130</a>
ADRESH	—	—	—	—	—	—	ADRES9	ADRES8	<a href="#">130</a>
ADRESL	ADRES7	ADRES6	ADRES5	ADRES4	ADRES3	ADRES2	ADRES1	ADRES0	<a href="#">130</a>
ANSELA	—	—	—	—	ANSA3	ANSA2	ANSA1	ANSA0	<a href="#">115</a>
ANSELB	—	—	ANSB5	ANSB4	—	ANSB2	ANSB1	—	<a href="#">118</a>
INTCON	GIE	PEIE	T0IE	INTE	IOCE	T0IF	INTF	IOCF	<a href="#">95</a>
PIE1	—	ADIE	BCLIE	SSPIE	—	—	TMR2IE	TMR1IE	<a href="#">96</a>
PIR1	—	ADIF	BCLIF	SSPIF	—	—	TMR2IF	TMR1IF	<a href="#">98</a>
TRISGPA	TRISA7	TRISA6	TRISA5	TRISA4	TRISA3	TRISA2	TRISA1	TRISA0	<a href="#">114</a>
TRISGPB	TRISB7	TRISB6	TRISB5	TRISB4	—	TRISB2	TRISB1	TRISB0	<a href="#">117</a>

**Legend:** — = unimplemented read as '0'. Shaded cells are not used for ADC module.

# MCP19110/11

---

NOTES:

## 23.0 TIMER0 MODULE

The Timer0 module is an 8-bit timer/counter with the following features:

- 8-bit timer/counter register (TMR0)
- 8-bit prescaler (independent of Watchdog Timer)
- Programmable internal or external clock source
- Programmable external clock edge selection
- Interrupt on overflow

Figure 23-1 is a block diagram of the Timer0 module.

**FIGURE 23-1: BLOCK DIAGRAM OF THE TIMER0**

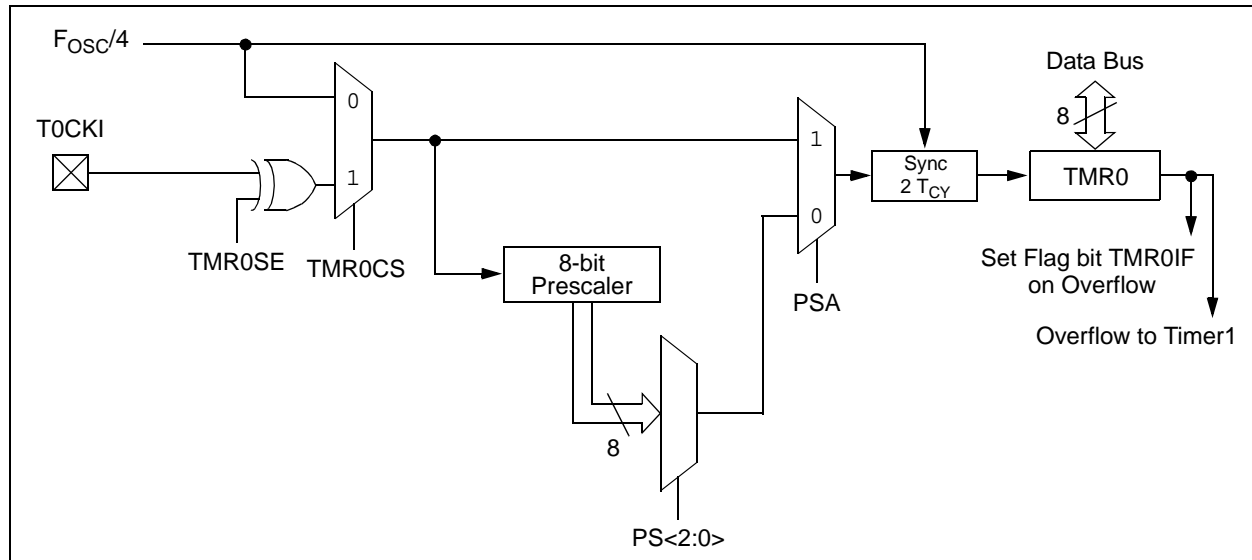

### 23.1 Timer0 Operation

The Timer0 module can be used as either an 8-bit timer or an 8-bit counter.

#### 23.1.1 8-BIT TIMER MODE

The Timer0 module will increment every instruction cycle, if used without a prescaler. 8-Bit Timer mode is selected by clearing the T0CS bit of the OPTION\_REG register.

When TMR0 is written, the increment is inhibited for two instruction cycles immediately following the write.

**Note:** The value written to the TMR0 register can be adjusted, in order to account for the two-instruction cycle delay when TMR0 is written.

#### 23.1.2 8-BIT COUNTER MODE

In 8-Bit Counter mode, the Timer0 module will increment on every rising or falling edge of the T0CKI pin. The incrementing edge is determined by the T0SE bit of the OPTION\_REG register.

8-Bit Counter mode using the T0CKI pin is selected by setting the T0CS bit in the OPTION\_REG register to '1'.

#### 23.1.3 SOFTWARE PROGRAMMABLE PRESCALER

A single software programmable prescaler is available for use with either Timer0 or the Watchdog Timer (WDT), but not both simultaneously. The prescaler assignment is controlled by the PSA bit of the OPTION\_REG register. To assign the prescaler to Timer0, the PSA bit must be cleared to '0'.

There are eight prescaler options for the Timer0 module ranging from 1:2 to 1:256. The prescale values are selectable via the PS<2:0> bits of the OPTION\_REG register. In order to have a 1:1 prescaler value for the Timer0 module, the prescaler must be disabled by setting the PSA bit of the OPTION\_REG register.

The prescaler is not readable or writable. When assigned to the Timer0 module, all instructions writing to the TMR0 register will clear the prescaler.

# MCP19110/11

## 23.1.4 SWITCHING PRESCALER BETWEEN TIMER0 AND WDT MODULES

As a result of having the prescaler assigned to either Timer0 or the WDT, it is possible to generate an unintended device Reset when switching prescaler values. When changing the prescaler assignment from Timer0 to the WDT module, the instruction sequence shown in [Example 23-1](#) must be executed.

### EXAMPLE 23-1: CHANGING PRESCALER (TIMER0 → WDT)

```
BANKSEL TMR0      ;
CLRWDW           ;Clear WDT
CLRF    TMR0     ;Clear TMR0 and
                ;prescaler
BANKSEL OPTION_REG ;
BSF    OPTION_REG,PSA ;Select WDT
CLRWDW           ;
MOVW   b'11111000' ;Mask prescaler
ANDWF  OPTION_REG,W ;bits
IORLW  b'00000101' ;Set WDT prescaler
MOVWF  OPTION_REG ;to 1:32
```

When changing the prescaler assignment from the WDT to the Timer0 module, the following instruction sequence must be executed (see [Example 23-2](#)).

### EXAMPLE 23-2: CHANGING PRESCALER (WDT → TIMER0)

```
CLRWDW           ;Clear WDT and
                ;prescaler
BANKSEL OPTION_REG ;
MOVW   b'11110000' ;Mask TMR0 select and
ANDWF  OPTION_REG,W ;prescaler bits
IORLW  b'00000011' ;Set prescale to 1:16
MOVWF  OPTION_REG ;
```

## 23.1.5 TIMER0 INTERRUPT

Timer0 will generate an interrupt when the TMR0 register overflows from FFh to 00h. The T0IF interrupt flag bit of the INTCON register is set every time the TMR0 register overflows, regardless of whether or not the Timer0 interrupt is enabled. The T0IF bit can only be cleared in software. The Timer0 interrupt enable is the T0IE bit of the INTCON register.

**Note:** The Timer0 interrupt cannot wake the processor from Sleep since the timer is frozen during Sleep.

## 23.1.6 USING TIMER0 WITH AN EXTERNAL CLOCK

When Timer0 is in Counter mode, the synchronization of the T0CKI input and the Timer0 register is accomplished by sampling the prescaler output on the Q2 and Q4 cycles of the internal phase clocks. Therefore, the high and low periods of the external clock source must meet the timing requirements as shown in [Section 5.0](#) “[Digital Electrical Characteristics](#)”.

## 23.1.7 OPERATION DURING SLEEP

Timer0 cannot operate while the processor is in Sleep mode. The contents of the TMR0 register will remain unchanged while the processor is in Sleep mode.

**TABLE 23-1: SUMMARY OF REGISTERS ASSOCIATED WITH TIMER0**

Name	Bit 7	Bit 6	Bit 5	Bit 4	Bit 3	Bit 2	Bit 1	Bit 0	Register on Page
INTCON	GIE	PEIE	T0IE	INTE	IOCFIE	T0IF	INTF	IOCF	96
OPTION_REG	RAPU	INTEDG	T0CS	T0SE	PSA	PS2	PS1	PS0	77
TMR0	Timer0 Module Register								135*
TRISGPA	TRISA7	TRISA6	TRISA5	TRISA4	TRISA3	TRISA2	TRISA1	TRISA0	114

**Legend:** — = Unimplemented locations, read as ‘0’. Shaded cells are not used by the Timer0 module.

\* Page provides register information.



## 24.0 TIMER1 MODULE WITH GATE CONTROL

The Timer1 module is a 16-bit timer with the following features:

- 16-bit timer register pair (TMR1H:TMR1L)
- Readable and Writable (both registers)
- Selectable internal clock source
- 2-bit prescaler
- Interrupt on overflow

Figure 24-1 is a block diagram of the Timer1 module.

**FIGURE 24-1: TIMER1 BLOCK DIAGRAM**

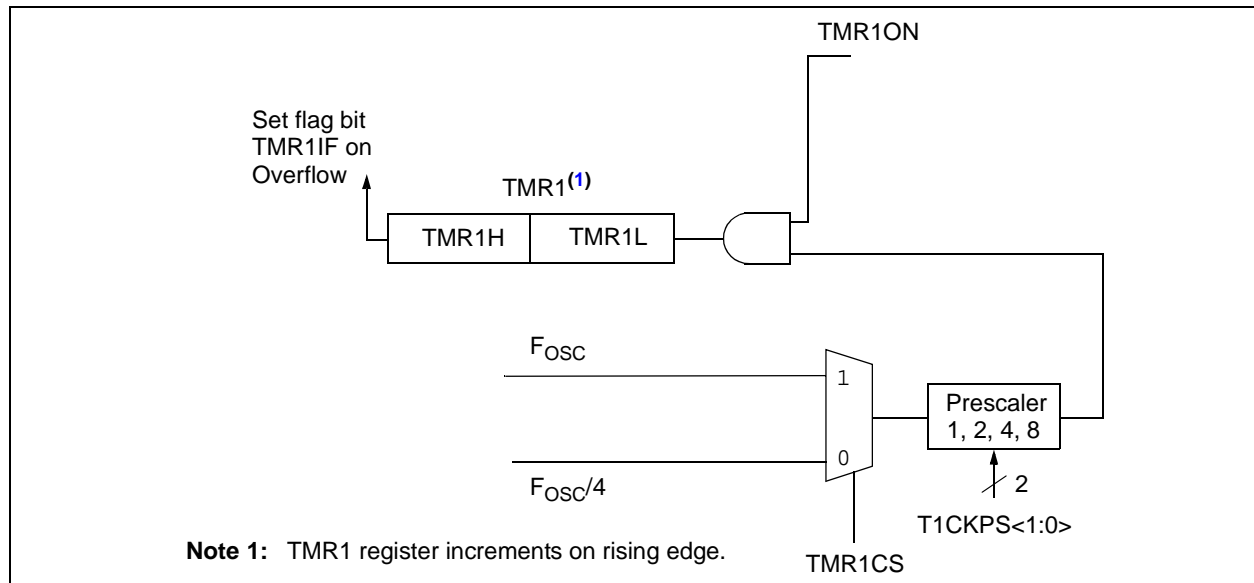

### 24.1 Timer1 Operation

The Timer1 module is a 16-bit incrementing timer which is accessed through the TMR1H:TMR1L register pair. Writes to TMR1H or TMR1L directly update the counter. The timer is incremented on every instruction cycle.

Timer1 is enabled by configuring the TMR1ON bit in the T1CON register. Table 24-1 displays the Timer1 enable selections.

### 24.2 Clock Source Selection

The TMR1CS bit of the T1CON register is used to select the clock source for Timer1. Table 24-1 displays the clock source selections.

#### 24.2.1 INTERNAL CLOCK SOURCE

The TMR1H:TMR1L register pair will increment on multiples of  $F_{OSC}$  or  $F_{OSC}/4$  as determined by the Timer1 prescaler.

As an example, when the  $F_{OSC}$  internal clock source is selected, the Timer1 register value will increment by four counts every instruction clock cycle.

**TABLE 24-1: CLOCK SOURCE SELECTIONS**

TMR1CS	Clock Source
1	8 MHz system Clock ( $F_{OSC}$ )
0	2 MHz instruction clock ( $F_{OSC}/4$ )

# MCP19110/11

## 24.3 Timer1 Prescaler

Timer1 has four prescaler options allowing 1, 2, 4 or 8 divisions of the clock input. The T1CKPS bits of the T1CON register control the prescale counter. The prescale counter is not directly readable or writable; however, the prescaler counter is cleared upon a write to TMR1H or TMR1L.

## 24.4 Timer1 Interrupt

The Timer1 register pair (TMR1H:TMR1L) increments to FFFFh and rolls over to 0000h. When Timer1 rolls over, the Timer1 interrupt flag bit of the PIR1 register is set. To enable the interrupt on rollover, you must set these bits:

- TMR1ON bit of the T1CON register
- TMR1IE bit of the PIE1 register
- PEIE bit of the INTCON register
- GIE bit of the INTCON register

The interrupt is cleared by clearing the TMR1IF bit in the Interrupt Service Routine.

**Note:** The TMR1H:TMR1L register pair and the TMR1IF bit should be cleared before enabling interrupts.

## 24.5 Timer1 in Sleep

Unlike other standard mid-range Timer1 modules, the MCP19110/11 Timer1 module only clocks from an internal system clock, and thus does not run during Sleep mode, nor can it be used to wake the device from this mode.

## 24.6 Timer1 Control Register

The Timer1 Control register (T1CON), shown in [Register 24-1](#), is used to control Timer1 and select the various features of the Timer1 module.

**REGISTER 24-1: T1CON: TIMER1 CONTROL REGISTER**

U-0	U-0	R/W-0	R/W-0	U-0	U-0	R/W-0	R/W-0
—	—	T1CKPS1	T1CKPS0	—	—	TMR1CS	TMR1ON
bit 7							bit 0

**Legend:**

R = Readable bit                      W = Writable bit                      U = Unimplemented bit, read as '0'  
-n = Value at POR                      '1' = Bit is set                      '0' = Bit is cleared                      x = Bit is unknown

- bit 7-6                      **Unimplemented:** Read as '0'
- bit 5-4                      **T1CKPS<1:0>:** Timer1 Input Clock Prescale Select bits  
11 = 1:8 Prescale value  
10 = 1:4 Prescale value  
01 = 1:2 Prescale value  
00 = 1:1 Prescale value
- bit 3-2                      **Unimplemented:** Read as '0'
- bit 1                      **TMR1CS:** Timer1 Clock Source Control bit  
1 = 8 MHz system clock (F<sub>OSC</sub>)  
0 = 2 MHz instruction clock (F<sub>OSC</sub>)
- bit 0                      **TMR1ON:** Timer1 On bit  
1 = Enables Timer1  
0 = Stops Timer1, Clears Timer1 gate flip-flop

**TABLE 24-2: SUMMARY OF REGISTERS ASSOCIATED WITH TIMER1**

Name	Bit 7	Bit 6	Bit 5	Bit 4	Bit 3	Bit 2	Bit 1	Bit 0	Register on Page
INTCON	GIE	PEIE	T0IE	INTE	IOCE	T0IF	INTF	IOCF	<a href="#">95</a>
PIE1	—	ADIE	BCLIE	SSPIE	—	—	TMR2IE	TMR1IE	<a href="#">95</a>
PIR1	—	ADIF	BCLIF	SSPIF	—	—	TMR2IF	TMR1IF	<a href="#">98</a>
TMR1H	Holding Register for the Most Significant Byte of the 16-bit TMR1 Register								<a href="#">137*</a>
TMR1L	Holding Register for the Least Significant Byte of the 16-bit TMR1 Register								<a href="#">137*</a>
T1CON	—	—	T1CKPS1	T1CKPS0	—	—	TMR1CS	TMR1ON	<a href="#">138</a>

**Legend:** — = unimplemented, read as '0'. Shaded cells are not used by the Timer1 module.

\* Page provides register information.

# MCP19110/11

## 25.0 TIMER2 MODULE

The Timer2 module is an 8-bit timer with the following features:

- 8-bit timer register (TMR2)
- 8-bit period register (PR2)
- Interrupt on TMR2 match with PR2
- Software programmable prescaler (1:1, 1:4, 1:16)

See [Figure 25-1](#) for a block diagram of Timer2.

### 25.1 Timer2 Operation

The clock input to the Timer2 module is the system clock ( $F_{OSC}$ ). The clock is fed into the Timer2 prescaler, which has prescale options of 1:1, 1:4 or 1:16. The output of the prescaler is then used to increment the TMR2 register.

The values of TMR2 and PR2 are constantly compared to determine when they match. TMR2 will increment from 00h until it matches the value in PR2. When a match occurs, TMR2 is reset to 00h on the next increment cycle.

The match output of the Timer2/PR2 comparator is used to set the TMR2IF interrupt flag bit in the PIR1 register.

The TMR2 and PR2 registers are both fully readable and writable. On any Reset, the TMR2 register is set to 00h and the PR2 register is set to FFh.

Timer2 is turned on by setting the TMR2ON bit in the T2CON register to a '1'. Timer2 is turned off by clearing the TMR2ON bit to a '0'.

The Timer2 prescaler is controlled by the T2CKPS bits in the T2CON register. The prescaler counter is cleared when:

- A write to TMR2 occurs.
- A write to T2CON occurs.
- Any device Reset occurs (Power-on Reset,  $\overline{MCLR}$  Reset, Watchdog Timer Reset, or Brown-out Reset).

**Note:** TMR2 is not cleared when T2CON is written.

**FIGURE 25-1: TIMER2 BLOCK DIAGRAM**

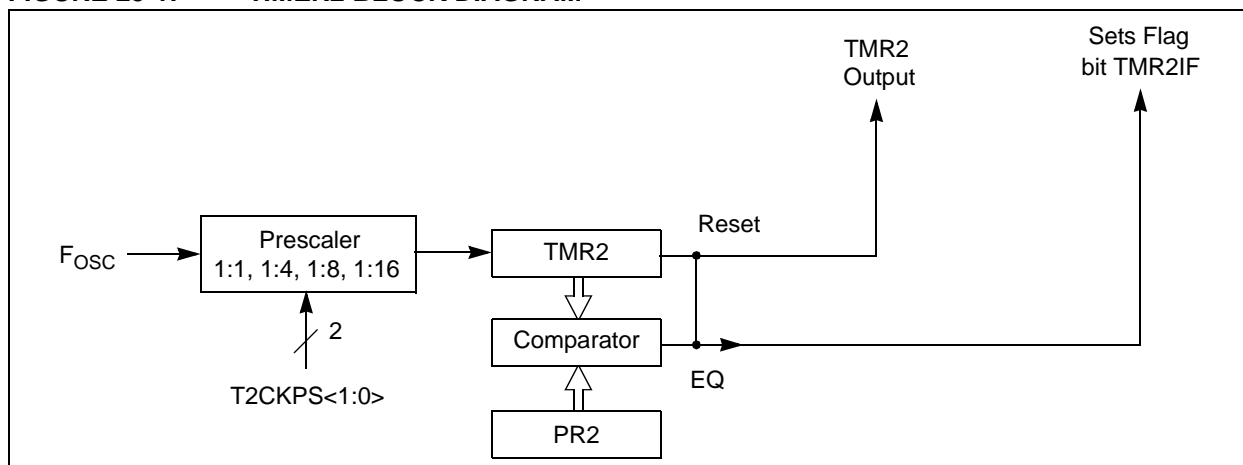

## 25.2 Timer2 Control Register

**REGISTER 25-1: T2CON: TIMER2 CONTROL REGISTER**

U-0	U-0	U-0	U-0	U-0	R/W-0	R/W-0	R/W-0
—	—	—	—	—	TMR2ON	T2CKPS1	T2CKPS0
bit 7						bit 0	

**Legend:**

R = Readable bit                      W = Writable bit                      U = Unimplemented bit, read as '0'  
 -n = Value at POR                      '1' = Bit is set                      '0' = Bit is cleared                      x = Bit is unknown

- bit 7-3            **Unimplemented:** Read as '0'
- bit 2            **TMR2ON:** Timer2 On bit  
                   1 = Timer2 is on  
                   0 = Timer2 is off
- bit 1-0        **T2CKPS<1:0>:** Timer2 Clock Prescale Select bits  
                   00 =Prescaler is 1  
                   01 =Prescaler is 4  
                   10 =Prescaler is 8  
                   11 =Prescaler is 16

**TABLE 25-1: SUMMARY OF REGISTERS ASSOCIATED WITH TIMER2**

Name	Bit 7	Bit 6	Bit 5	Bit 4	Bit 3	Bit 2	Bit 1	Bit 0	Register on Page
INTCON	GIE	PEIE	T0IE	INTE	IOCE	T0IF	INTF	IOCF	95
PIE1	—	ADIE	BCLIE	SSPIE	—	—	TMR2IE	TMR1IE	96
PIR1	—	ADIF	BCLIF	SSPIF	—	—	TMR2IF	TMR1IF	98
PR2	Timer2 Module Period Register								140*
T2CON	—	—	—	—	—	TMR2ON	T2CKPS1	T2CKPS0	141
TMR2	Holding Register for the 8-bit TMR2 Time Base								140*

**Legend:** — = unimplemented read as '0'. Shaded cells are not used for Timer2 module.

\* Page provides register information.

# MCP19110/11

---

NOTES:

## 26.0 PWM MODULE

The CCP module implemented on the MCP19110/11 is a modified version of the CCP module found in standard mid-range microcontrollers. In the MCP19110/11, the PWM module is used to generate the system clock or system oscillator. This system clock will control the MCP19110/11 switching frequency, as well as set the maximum allowable duty cycle. The PWM module does not continuously adjust the duty cycle to control the output voltage. This is accomplished by the analog control loop and associated circuitry.

### 26.1 Standard Pulse-Width Modulation (PWM) Mode

The PWM module output signal is used to set the operating switching frequency and maximum allowable duty cycle of the MCP19110/11. The actual duty cycle on the HDRV and LDRV is controlled by the analog PWM control loop. However, this duty cycle cannot be greater than the value in the PWMRL register.

There are two modes of operation that concern the system clock PWM signal. These modes are stand-alone (non-frequency synchronization) and frequency synchronization.

#### 26.1.1 STAND-ALONE (NON-FREQUENCY SYNCHRONIZATION) MODE

When the MCP19110/11 is running stand-alone, the PWM signal functions as the system clock. It is operating at the programmed switching frequency with a programmed maximum duty cycle ( $D_{CLOCK}$ ). The programmed maximum duty cycle is not adjusted on a cycle-by-cycle basis to control the MCP19110/11 system output. The required duty cycle ( $D_{BUCK}$ ) to control the output is adjusted by the MCP19110/11 analog control loop and associated circuitry.  $D_{CLOCK}$  does, however, set the maximum allowable  $D_{BUCK}$ .

#### EQUATION 26-1:

$$D_{BUCK} < 1 - D_{CLOCK}$$

#### 26.1.2 SWITCHING FREQUENCY SYNCHRONIZATION MODE

The MCP19110/11 can be programmed to be a switching frequency MASTER or SLAVE device. The MASTER device functions as described in [Section 26.1.1 “Stand-Alone \(Non-Frequency Synchronization\) Mode”](#) with the exception of the system clock also being applied to GPA1.

A SLAVE device will receive the MASTER system clock on GPA1. This MASTER system clock will be OR'ed with the output of the TIMER2 module. This OR'ed signal will latch PWMRL into PWMRH and PWMPHL into PWMPHH.

[Figure 26-1](#) shows a simplified block diagram of the CCP module in PWM mode.

The PWMPHL register allows for a phase shift to be added to the SLAVE system clock.

It is desired to have the MCP19110/11 SLAVE device's system clock start point shifted by a programmed amount from the MASTER system clock. This SLAVE phase shift is specified by writing to the PWMPHL register. The SLAVE phase shift can be calculated by using the following equation.

#### EQUATION 26-2:

$$SLAVE\ PHASE\ SHIFT = PWMPHL \cdot T_{OSC} \cdot (T2\ PRESCALE\ VALUE)$$

# MCP19110/11

**FIGURE 26-1: SIMPLIFIED PWM BLOCK DIAGRAM**

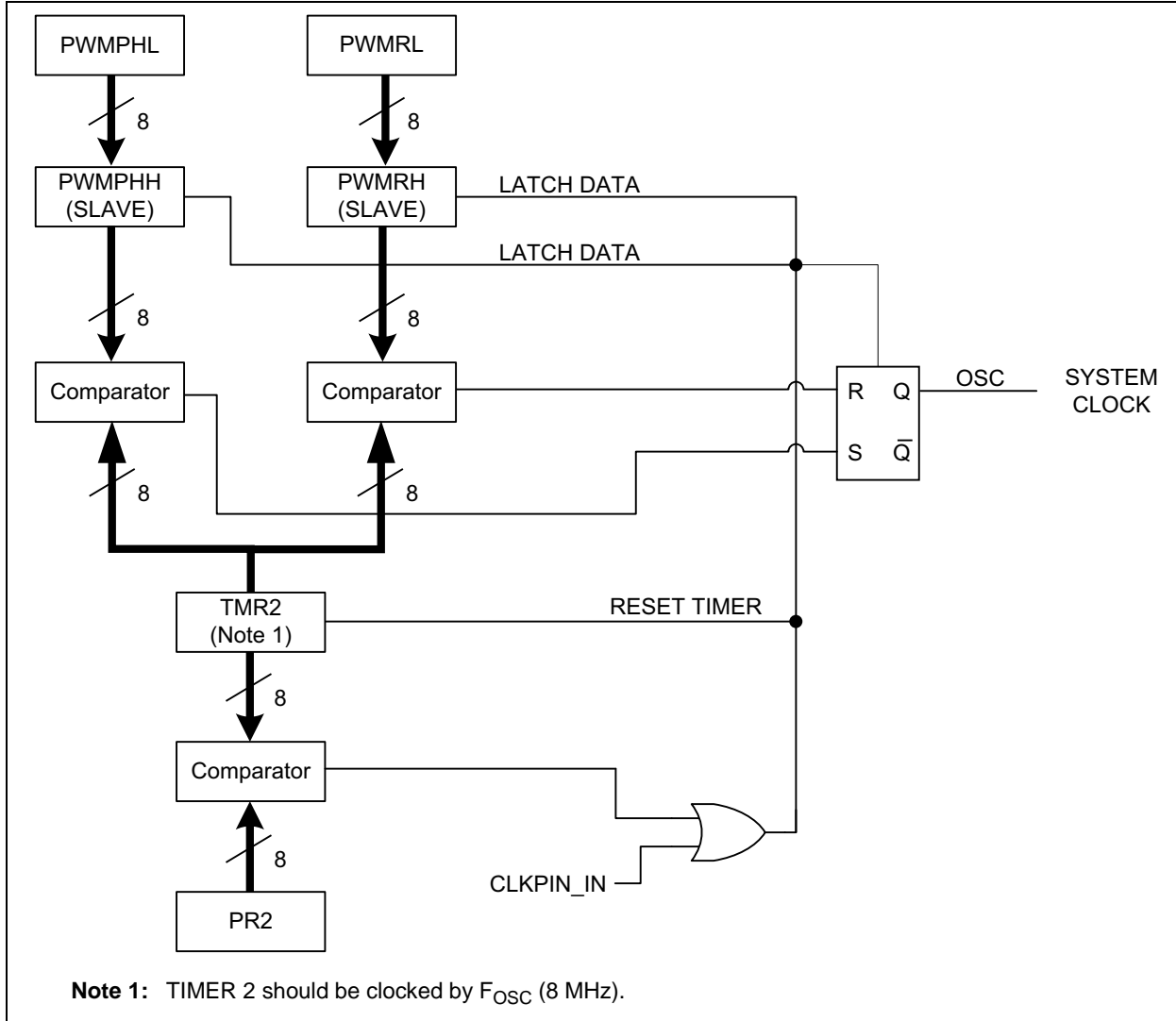

A PWM output (Figure 26-2) has a time base (period) and a time that the output stays high (duty cycle). The frequency of the PWM is the inverse of the period (1/period).

### 26.1.3 PWM PERIOD

The PWM period is specified by writing to the PR2 register. The PWM period can be calculated using the following equation:

**FIGURE 26-2: PWM OUTPUT**

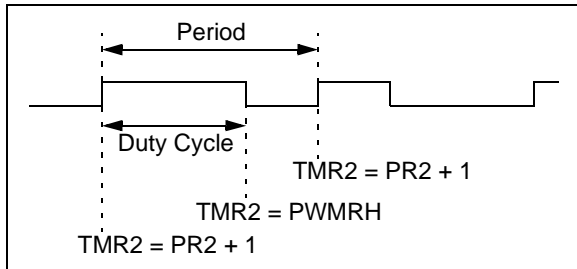

**EQUATION 26-3:**

$$PWM\ PERIOD = [(PR2) + 1] \times T_{OSC} \times (T2\ PRESCALE\ VALUE)$$

When TMR2 is equal to PR2, the following two events occur on the next increment cycle:

- TMR2 is cleared
- The PWM duty cycle is latched from PWMRL into PWMRH



## 26.1.4 PWM DUTY CYCLE ( $D_{\text{CLOCK}}$ )

The PWM duty cycle ( $D_{\text{CLOCK}}$ ) is specified by writing to the PWMRL register. Up to 8-bit resolution is available. The following equation is used to calculate the PWM duty cycle ( $D_{\text{CLOCK}}$ ):

### EQUATION 26-4:

$$PWM \text{ DUTY CYCLE} = PWMRL \times T_{OSC} \times (T2 \text{ PRESCALE VALUE})$$

The PWMRL bits can be written to at any time, but the duty cycle value is not latched into PWMRH until after a match between PR2 and TMR2 occurs.

## 26.2 Operation during Sleep

When the device is placed in Sleep, the allocated timer will not increment and the state of the module will not change. If the CLKPIN pin is driving a value, it will continue to drive that value. When the device wakes up, it will continue from this state.

**TABLE 26-1: SUMMARY OF REGISTERS ASSOCIATED WITH PWM MODULE**

Name	Bit 7	Bit 6	Bit 5	Bit 4	Bit 3	Bit 2	Bit 1	Bit 0	Register on Page
APFCON	—	—	—	—	—	—	—	CLKSEL	112
T2CON	—	—	—	—	—	TMR2ON	T2CKPS1	T2CKPS0	141
PR2	Timer2 Module Period Register								140*
PWMRL	PWM Register Low Byte								143*
PWMPHL	SLAVE Phase Shift Byte								143*
BUFFCON	MLTPH2	MLTPH1	MLTPH0	ASEL4	ASEL3	ASEL2	ASEL1	ASEL0	58

**Legend:** — = Unimplemented locations, read as '0'. Shaded cells are not used by Capture mode.

\* Page provides register information.

# MCP19110/11

---

NOTES:

## 27.0 MASTER SYNCHRONOUS SERIAL PORT (MSSP) MODULE

### 27.1 Master SSP (MSSP) Module Overview

The Master Synchronous Serial Port (MSSP) module is a serial interface useful for communicating with other peripheral or microcontroller devices. These peripheral devices may be Serial EEPROMs, shift registers, display drivers, A/D converters, etc. The MSSP module only operates in Inter-Integrated Circuit (I<sup>2</sup>C) mode.

The I<sup>2</sup>C interface supports the following modes and features:

- Master mode
- Slave mode
- Byte NACKing (Slave mode)
- Limited Multi-Master support
- 7-bit and 10-bit addressing
- Start and Stop interrupts
- Interrupt masking
- Clock stretching
- Bus collision detection
- General call address matching
- Dual Address masking
- Address Hold and Data Hold modes
- Selectable SDA hold times

Figure 27-1 is a block diagram of the I<sup>2</sup>C interface module in Master mode. Figure 27-2 is a diagram of the I<sup>2</sup>C interface module in Slave mode.

**FIGURE 27-1: MSSP BLOCK DIAGRAM (I<sup>2</sup>C MASTER MODE)**

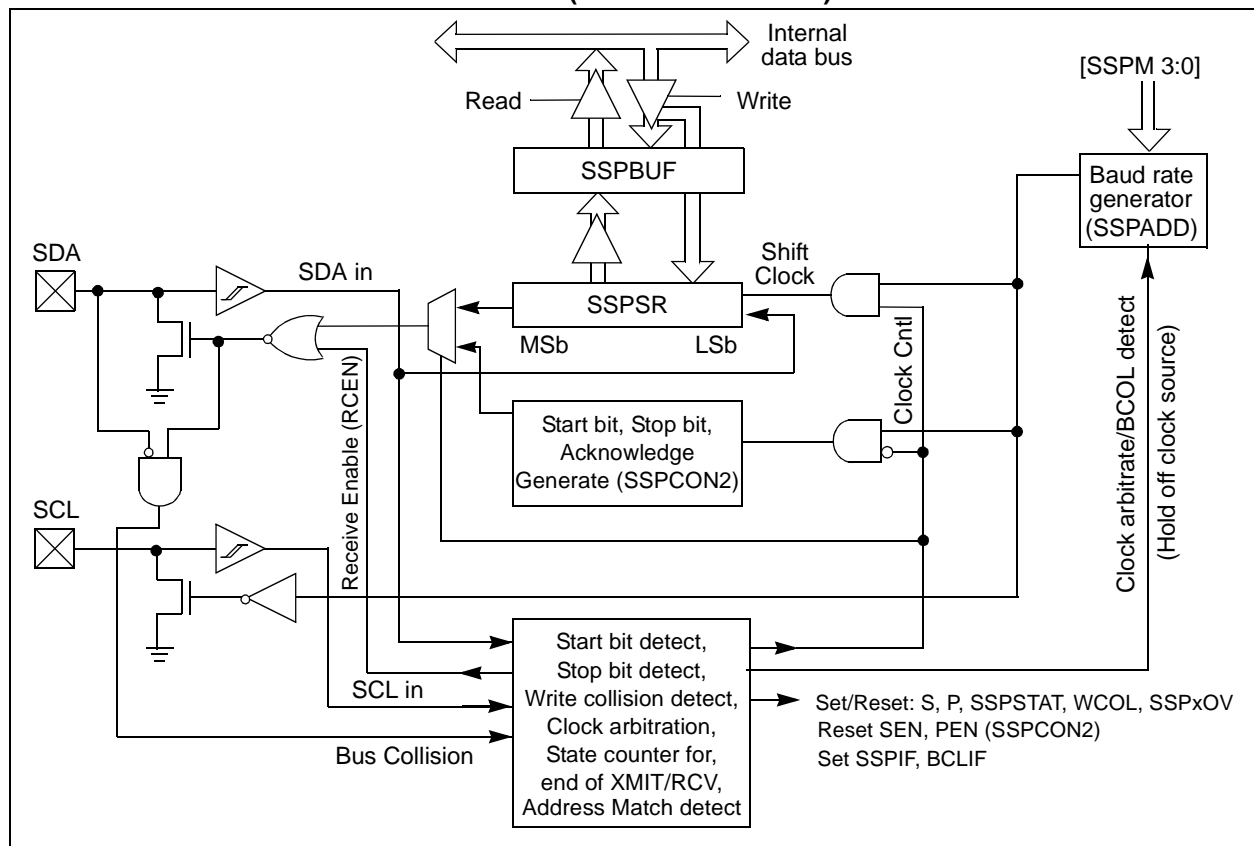

# MCP19110/11

**FIGURE 27-2: MSSP BLOCK DIAGRAM (I<sup>2</sup>C SLAVE MODE)**

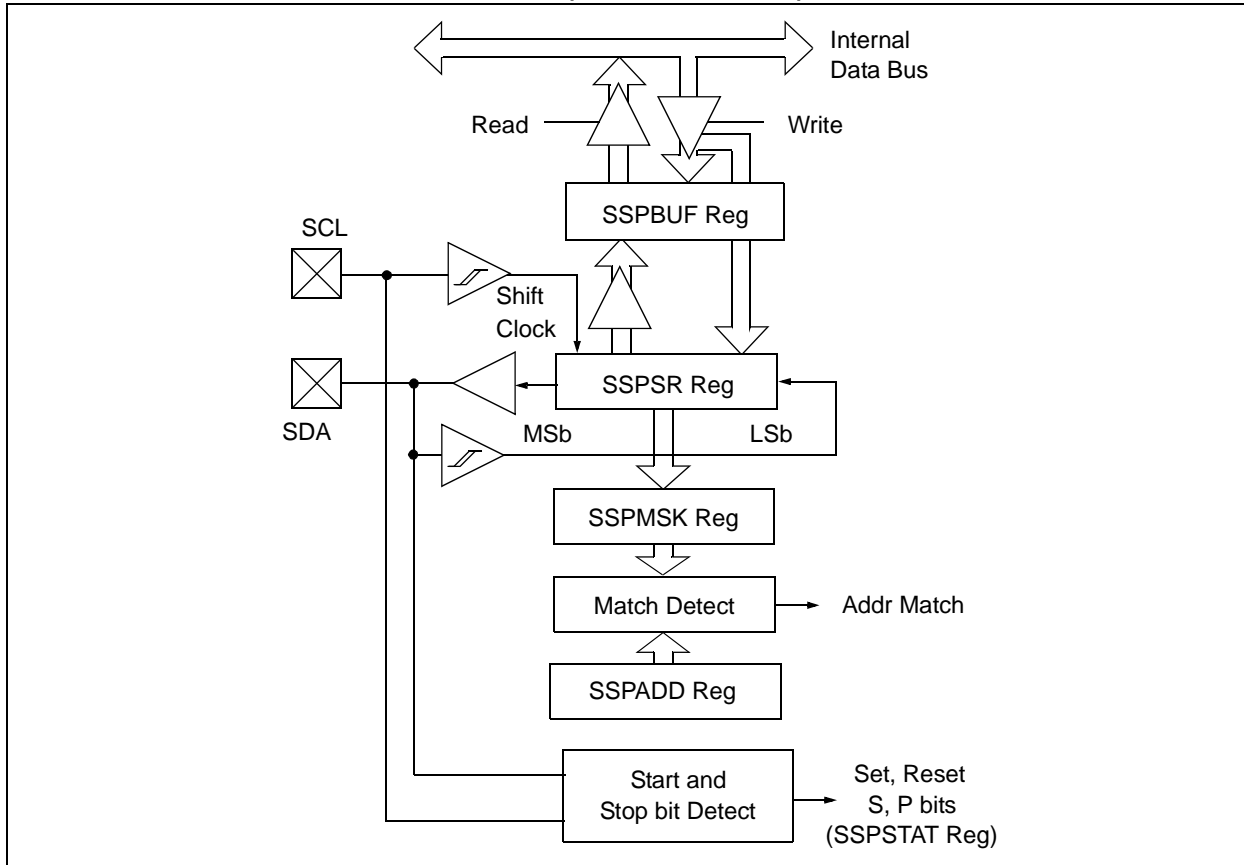

## 27.2 I<sup>2</sup>C MODE OVERVIEW

The Inter-Integrated Circuit Bus (I<sup>2</sup>C) is a multi-master serial data communication bus. Devices communicate in a master/slave environment, where the master devices initiate the communication. A Slave device is controlled through addressing.

The MSSP module has eight registers for I<sup>2</sup>C operation. They are the:

- MSSP Status Register (SSPSTAT)
- MSSP Control Register1 (SSPCON1)
- MSSP Control Register2 (SSPCON2)
- MSSP Control Register3 (SSPCON3)
- Serial Receive/Transmit Buffer (SSPBUF)
- MSSP Shift Register (SSPSR) - Not directly accessible
- MSSP Address Register (SSPADD)
- MSSP Address Register2 (SSPADD2)
- MSSP Address Mask Register1 (SSPMSK)
- MSSP Address Mask Register2 (SSPMSK2)

The SSPCON1 register is used to define the I<sup>2</sup>C mode. Four selection bits (SSPCON1<3:0>) allow one of the following I<sup>2</sup>C modes to be selected:

- I<sup>2</sup>C Slave mode (7-bit address)
- I<sup>2</sup>C Slave mode (10-bit address)
- I<sup>2</sup>C Master mode, clock = OSC/4 (SSPADD +1)
- I<sup>2</sup>C firmware controlled Master mode (Slave idle)

The SSPSTAT register gives the status of the data transfer. This information includes detection of a START or STOP bit, specifies if the data received byte was data or address, if the next byte is completion of the 10-bit address, and if this will be a read or write data transfer.

The SSPBUF is the register to which transfer data is written to or read from. The SSPSR register shifts the data in or out of the device. In receive operation, the SSPBUF and SSPSR create a double buffer receiver. This allows reception of the next byte to begin before reading the last byte of received data. When the complete byte is received before the SSPBUF register is read, a receiver overflow has occurred and the SPOV bit (SSPCON1<6>) is set and the byte in the SSPSR is lost.

The I<sup>2</sup>C bus specifies two signal connections:

- Serial Clock (SCL)
- Serial Data (SDA)

Both the SCL and SDA connections are bidirectional open-drain lines, each requiring pull-up resistors for the supply voltage. Pulling the line to ground is considered a logical zero; letting the line float is considered a logical one.

Before selecting any I<sup>2</sup>C mode, the SCL and SDA pins must be programmed to inputs by setting the appropriate TRIS bits. Selecting I<sup>2</sup>C mode, by setting the SSPEN bit, enables the SCL and SDA pins to be used as clock and data lines in I<sup>2</sup>C mode.

Figure 27-3 shows a typical connection between two devices configured as master and slave.

**FIGURE 27-3: I<sup>2</sup>C MASTER/SLAVE CONNECTION**

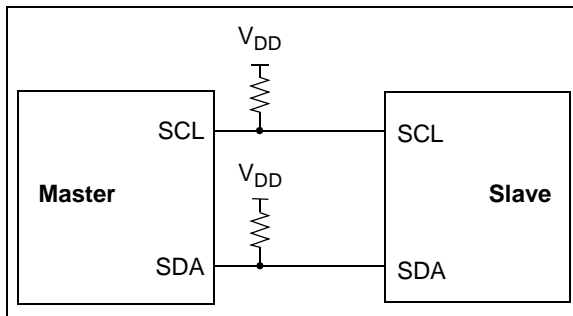

The I<sup>2</sup>C bus can operate with one or more master devices and one or more slave devices.

There are four potential modes of operation for a given device:

- Master Transmit mode  
(master is transmitting data to a slave)
- Master Receive mode  
(master is receiving data from a slave)
- Slave Transmit mode  
(slave is transmitting data to a master)
- Slave Receive mode  
(slave is receiving data from the master)

To begin communication, a master device starts out in Master Transmit mode. The master device sends out a Start bit followed by the address byte of the slave it intends to communicate with. This is followed by a single Read/Write bit, which determines whether the master intends to transmit to or receive data from the slave device.

If the requested slave exists on the bus, it will respond with an Acknowledge bit, otherwise known as an ACK. The master then continues in either Transmit mode or Receive mode and the slave continues in the complement, either in Receive mode or Transmit mode, respectively.

A Start bit is indicated by a high-to-low transition of the SDA line while the SCL line is held high. Address and data bytes are sent out, Most Significant bit (MSb) first. The Read/Write bit is sent out as a logical one when the master intends to read data from the slave, and is sent out as a logical zero when it intends to write data to the slave.

The Acknowledge bit ( $\overline{\text{ACK}}$ ) is an active-low signal, which holds the SDA line low to indicate to the transmitter that the slave device has received the transmitted data and is ready to receive more.

The transition of a data bit is always performed while the SCL line is held low. Transitions that occur while the SCL line is held high are used to indicate Start and Stop bits.

If the master intends to write to the slave, then it repeatedly sends out a byte of data, with the slave responding after each byte with an  $\overline{\text{ACK}}$  bit. In this example, the master device is in Master Transmit mode, and the slave is in Slave Receive mode.

If the master intends to read from the slave, then it repeatedly receives a byte of data from the slave, and responds after each byte with an  $\overline{\text{ACK}}$  bit. In this example, the master device is in Master Receive mode, and the slave is Slave Transmit mode.

On the last byte of data communicated, the master device may end the transmission by sending a Stop bit. If the master device is in Receive mode, it sends the Stop bit in place of the last  $\overline{\text{ACK}}$  bit. A Stop bit is indicated by a low-to-high transition of the SDA line, while the SCL line is held high.

In some cases, the master may want to maintain control of the bus and reinitiate another transmission. If so, the master device may send another Start bit in place of the Stop bit or last ACK bit when it is in receive mode.

The I<sup>2</sup>C bus specifies three message protocols:

- Single message where a master writes data to a slave
- Single message where a master reads data from a slave
- Combined message where a master initiates a minimum of two writes, or two reads, or a combination of writes and reads, to one or more slaves

When one device is transmitting a logical one, or letting the line float, and a second device is transmitting a logical zero, or holding the line low, the first device can detect that the line is not a logical one. This detection, when used on the SCL line, is called clock stretching. Clock stretching gives slave devices a mechanism to control the flow of data. When this detection is used on the SDA line, it is called arbitration. Arbitration ensures that there is only one master device communicating at any single time.

## 27.2.1 CLOCK STRETCHING

When a slave device has not completed processing data, it can delay the transfer of more data through the process of Clock Stretching. An addressed slave device may hold the SCL clock line low after receiving or sending a bit, indicating that it is not yet ready to continue. The master that is communicating with the slave will attempt to raise the SCL line in order to transfer the next bit, but will detect that the clock line has not yet been released. Because the SCL connection is open-drain, the slave has the ability to hold that line low until it is ready to continue communicating.

Clock stretching allows receivers that cannot keep up with a transmitter to control the flow of incoming data.

## 27.2.2 ARBITRATION

Each master device must monitor the bus for Start and Stop bits. If the device detects that the bus is busy, it cannot begin a new message until the bus returns to an Idle state.

However, two master devices may try to initiate a transmission on or about the same time. When this occurs, the process of arbitration begins. Each transmitter checks the level of the SDA data line and compares it to the level that it expects to find. The first transmitter to observe that the two levels don't match, loses arbitration, and must stop transmitting on the SDA line.

For example, if one transmitter holds the SDA line to a logical one (lets it float) and a second transmitter holds it to a logical zero (pulls it low), the result is that the SDA line will be low. The first transmitter then observes that the level of the line is different than expected and concludes that another transmitter is communicating.

The first transmitter to notice this difference is the one that loses arbitration and must stop driving the SDA line. If this transmitter is also a master device, it also must stop driving the SCL line. It then can monitor the lines for a Stop condition before trying to reissue its transmission. In the meantime, the other device that has not noticed any difference between the expected and actual levels on the SDA line continues with its original transmission. It can do so without any complications, because so far, the transmission appears exactly as expected with no other transmitter disturbing the message.

Slave Transmit mode can also be arbitrated, when a master addresses multiple slaves, but this is less common.

If two master devices are sending a message to two different slave devices at the address stage, the master sending the lower slave address always wins arbitration. When two master devices send messages to the same slave address, and addresses can sometimes refer to multiple slaves, the arbitration process must continue into the data stage.

Arbitration usually occurs very rarely, but it is a necessary process for proper multi-master support.

## 27.3 I<sup>2</sup>C MODE OPERATION

All MSSP I<sup>2</sup>C communication is byte oriented and shifted out MSb first. Six SFR registers and two interrupt flags interface the module with the PIC microcontroller and user software. Two pins, SDA and SCL, are exercised by the module to communicate with other external I<sup>2</sup>C devices.

### 27.3.1 BYTE FORMAT

All communication in I<sup>2</sup>C is done in 9-bit segments. A byte is sent from a Master to a Slave or vice-versa, followed by an Acknowledge bit sent back. After the 8<sup>th</sup> falling edge of the SCL line, the device outputting data on the SDA changes that pin to an input and reads in an acknowledge value on the next clock pulse.

The clock signal, SCL, is provided by the master. Data is valid to change while the SCL signal is low, and sampled on the rising edge of the clock. Changes on the SDA line while the SCL line is high define special conditions on the bus, explained below.

### 27.3.2 DEFINITION OF I<sup>2</sup>C TERMINOLOGY

There is language and terminology in the description of I<sup>2</sup>C communication that have definitions specific to I<sup>2</sup>C. That word usage is defined below and may be used in the rest of this document without explanation. This table was adapted from the Philips I<sup>2</sup>C specification.

### 27.3.3 SDA AND SCL PINS

On the MCP19110/11, the SCL and SDA pins are always open-drain. These pins should be set by the user to inputs by setting the appropriate TRIS bits.

<b>Note:</b> Data is tied to output zero when an I <sup>2</sup> C mode is enabled.
--

## 27.3.4 SDA HOLD TIME

The hold time of the SDA pin is selected by the SDAHT bit of the SSPCON3 register. Hold time is the time SDA is held valid after the falling edge of SCL. Setting the SDAHT bit selects a longer 300 ns minimum hold time and may help on buses with large capacitance.

**TABLE 27-1: I<sup>2</sup>C BUS TERMS**

TERM	Description
Transmitter	The device which shifts data out onto the bus.
Receiver	The device which shifts data in from the bus.
Master	The device that initiates a transfer, generates clock signals and terminates a transfer.
Slave	The device addressed by the master.
Multi-Master	A bus with more than one device that can initiate data transfers.
Arbitration	Procedure to ensure that only one master at a time controls the bus. Winning arbitration ensures that the message is not corrupted.
Synchronization	Procedure to synchronize the clocks of two or more devices on the bus.
Idle	No master is controlling the bus, and both SDA and SCL lines are high.
Active	Any time one or more master devices are controlling the bus.
Addressed Slave	Slave device that has received a matching address and is actively being clocked by a master.
Matching Address	Address byte that is clocked into a slave that matches the value stored in SSPADDx.
Write Request	Slave receives a matching address with R/W bit clear, and is ready to clock in data.
Read Request	Master sends an address byte with the R/W bit set, indicating that it wishes to clock data out of the Slave. This data is the next and all following bytes until a Restart or Stop.
Clock Stretching	When a device on the bus holds SCL low to stall communication.
Bus Collision	Any time the SDA line is sampled low by the module while it is outputting and expected high state.

## 27.3.5 START CONDITION

The I<sup>2</sup>C specification defines a Start condition as a transition of SDA from a high to a low state, while SCL line is high. A Start condition is always generated by the master and signifies the transition of the bus from an Idle to an Active state. Figure 27-4 shows the wave forms for Start and Stop conditions.

A bus collision can occur on a Start condition if the module samples the SDA line low before asserting it low. This does not conform to the I<sup>2</sup>C Specification, that states no bus collision can occur on a Start.

## 27.3.6 STOP CONDITION

A Stop condition is a transition of the SDA line from low-to-high state while the SCL line is high.

**Note:** At least one SCL low time must appear before a Stop is valid, therefore, if the SDA line goes low then high again while the SCL line stays high, only the Start condition is detected.

## 27.3.7 RESTART CONDITION

A Restart is valid any time that a Stop would be valid. A master can issue a Restart if it wishes to hold the bus after terminating the current transfer. A Restart has the same effect on the slave that a Start would, resetting all slave logic and preparing it to clock in an address. The master may want to address the same or another slave.

In 10-bit Addressing Slave mode, a Restart is required for the master to clock data out of the addressed slave. Once a slave has been fully addressed, matching both high and low address bytes, the master can issue a Restart and the high address byte with the R/W bit set. The slave logic will then hold the clock and prepare to clock out data.

After a full match with R/W clear in 10-bit mode, a prior match flag is set and maintained. Until a Stop condition, a high address with R/W clear or a high address match fails.

# MCP19110/11

## 27.3.8 START/STOP CONDITION INTERRUPT MASKING

The SCIE and PCIE bits of the SSPCON3 register can enable the generation of an interrupt in Slave modes that do not typically support this function. These bits will have no effect on slave modes where interrupt on Start and Stop detect are already enabled.

**FIGURE 27-4: I<sup>2</sup>C START AND STOP CONDITIONS**

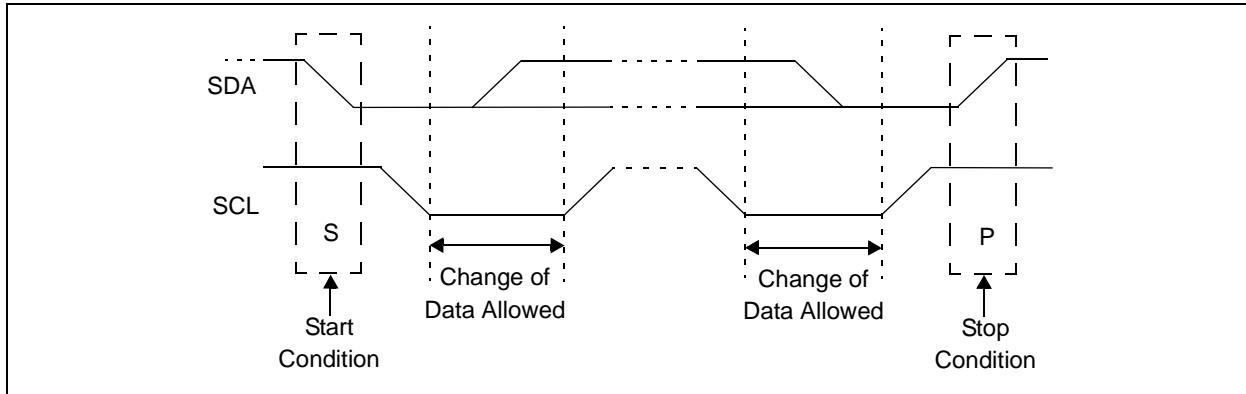

**FIGURE 27-5: I<sup>2</sup>C RESTART CONDITION**

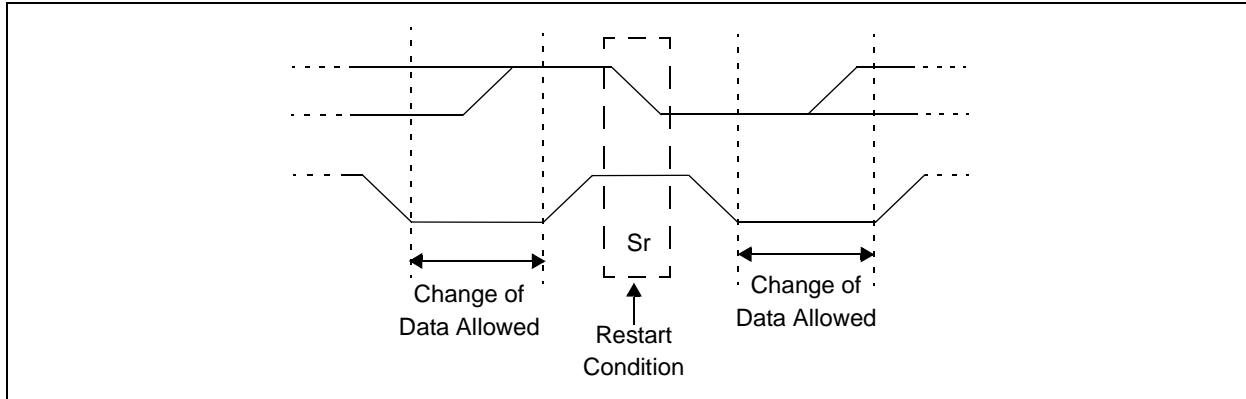

## 27.3.9 ACKNOWLEDGE SEQUENCE

The 9<sup>th</sup> SCL pulse for any transferred byte in I<sup>2</sup>C is dedicated as an Acknowledge. It allows receiving devices to respond back to the transmitter by pulling the SDA line low. The transmitter must release control of the line during this time to shift in the response. The Acknowledge ( $\overline{\text{ACK}}$ ) is an active-low signal, pulling the SDA line low indicates to the transmitter that the device has received the transmitted data and is ready to receive more.

The result of an  $\overline{\text{ACK}}$  is placed in the ACKSTAT bit of the SSPCON2 register.

Slave software, when the AHEN and DHEN bits are set, allow the user to set the  $\overline{\text{ACK}}$  value sent back to the transmitter. The ACKDT bit of the SSPCON2 register is set/cleared to determine the response.

Slave hardware will generate an  $\overline{\text{ACK}}$  response if the AHEN and DHEN bits of the SSPCON3 register are clear.

There are certain conditions where an  $\overline{\text{ACK}}$  will not be sent by the slave. If the BF bit of the SSPSTAT register or the SSPOV bit of the SSPCON1 register are set when a byte is received, an  $\overline{\text{ACK}}$  will not be sent.

When the module is addressed, after the 8<sup>th</sup> falling edge of SCL on the bus, the ACKTIM bit of the SSPCON3 register is set. The ACKTIM bit indicates the acknowledge time of the active bus. The ACKTIM Status bit is only active when the AHEN bit or DHEN bit is enabled.



## 27.4 I<sup>2</sup>C SLAVE MODE OPERATION

The MSSP Slave mode operates in one of the four modes selected in the SSPM bits of SSPCON1 register. The modes can be divided into 7-bit and 10-bit Addressing mode. 10-bit Addressing mode operates the same as 7-bit, with some additional overhead for handling the larger addresses.

Modes with Start and Stop bit interrupts operate the same as the other modes. The exception is the SSPIF bit getting set upon detection of a Start, Restart or Stop condition.

### 27.4.1 SLAVE MODE ADDRESSES, SSPADD

The SSPADD register ([Register 27-7](#)) contains the Slave mode address. The first byte received after a Start or Restart condition is compared against the value stored in this register. If the byte matches, the value is loaded into the SSPBUF register and an interrupt is generated. If the value does not match, the module goes idle and no indication is given to the software that anything happened.

The SSPMSK register ([Register 27-6](#)) affects the address matching process. See [Section 27.4.10 “SSPMSKx Register”](#) for more information.

### 27.4.2 SECOND SLAVE MODE ADDRESS, SSPADD2

The SSPADD2 register ([Register 27-9](#)) contains a second Slave mode address. To enable the use of this second Slave mode address, bit 0 must be set. The first byte received after a Start or Restart condition is compared against the value stored in this register. If the byte matches, the value is loaded into the SSPBUF register and an interrupt is generated. If the value does not match, the module goes Idle and no indication is given to the software that anything happened.

The SSPMSK2 register, [Register 27-8](#), affects the address matching process. See [Section 27.4.10 “SSPMSKx Register”](#) for more information.

#### 27.4.2.1 I<sup>2</sup>C Slave 7-bit Addressing Mode

In 7-bit Addressing mode, the LSb of the received data byte is ignored when determining if there is an address match.

#### 27.4.2.2 I<sup>2</sup>C Slave 10-bit Addressing Mode

In 10-bit Addressing mode, the first received byte is compared to the binary value of '1 1 1 1 0 A9 A8 0'. A9 and A8 are the two MSb of the 10-bit address and stored in bits 2 and 1 of the SSPADDx register.

After the acknowledge of the high byte, the UA bit is set, and SCL is held low until the user updates SSPADDx with the low address. The low address byte is clocked in and all eight bits are compared to the low address value in SSPADDx. Even if there is no address match, SSPIF and UA are set, and SCL is held low until SSPADDx is updated to receive a high byte again. When SSPADDx is updated, the UA bit is cleared. This ensures the module is ready to receive the high address byte on the next communication.

A high and low address match as a write request is required at the start of all 10-bit addressing communication. A transmission can be initiated by issuing a Restart once the slave is addressed, and clocking in the high address with the  $\overline{R/W}$  bit set. The slave hardware will then acknowledge the read request and prepare to clock out data. This is only valid for a slave after it has received a complete high and low address byte match.

### 27.4.3 SLAVE RECEPTION

When the  $\overline{R/W}$  bit of a matching received address byte is clear, the  $\overline{R/W}$  bit of the SSPSTAT register is cleared. The received address is loaded into the SSPBUF register and acknowledged.

When an overflow condition exists for a received address, then not Acknowledge is given. An overflow condition is defined as either bit BF of the SSPSTAT register is set, or bit SSPOV of the SSPCON1 register is set. The BOEN bit of the SSPCON3 register modifies this operation. For more information, see [Register 27-5](#).

An MSSP interrupt is generated for each transferred data byte. Flag bit, SSPIF, must be cleared by software.

When the SEN bit of the SSPCON2 register is set, SCL will be held low (clock stretch) following each received byte. The clock must be released by setting the CKP bit of the SSPCON1 register, except sometimes in 10-bit mode.

## 27.4.3.1 7-bit Addressing Reception

This section describes a standard sequence of events for the MSSP module configured as an I<sup>2</sup>C Slave in 7-bit Addressing mode, all decisions made by hardware or software and their effect on reception. [Figure 27-6](#) and [Figure 27-7](#) are used as a visual reference for this description.

This is a step-by-step process of what typically must be done to accomplish I<sup>2</sup>C communication.

1. Start bit detected.
2. S bit of SSPSTAT is set; SSPIF is set if interrupt on Start detect is enabled.
3. Matching address with R/W bit clear is received.
4. The slave pulls SDA low sending an  $\overline{\text{ACK}}$  to the master, and sets SSPIF bit.
5. Software clears the SSPIF bit.
6. Software reads received address from SSPBUF clearing the BF flag.
7. If SEN = 1, Slave software sets CKP bit to release the SCL line.
8. The master clocks out a data byte.
9. Slave drives SDA low, sending an  $\overline{\text{ACK}}$  to the master, and sets SSPIF bit.
10. Software clears SSPIF.
11. Software reads the received byte from SSPBUF clearing BF.
12. Steps 8–12 are repeated for all received bytes from the Master.
13. Master sends Stop condition, setting P bit of SSPSTAT, and the bus goes Idle.

## 27.4.3.2 7-bit Reception with AHEN and DHEN

Slave device reception with AHEN and DHEN set operates the same as without these options, with extra interrupts and clock stretching added after the 8<sup>th</sup> falling edge of SCL. These additional interrupts allow the slave software to decide whether it wants to  $\overline{\text{ACK}}$  the receive address or data byte, rather than the hardware. This functionality adds support for PMBus that was not present on previous versions of this module.

This list describes the steps that need to be taken by slave software to use these options for I<sup>2</sup>C communication. [Figure 27-8](#) displays a module using both address and data holding. [Figure 27-9](#) includes the operation with the SEN bit of the SSPCON2 register set.

1. S bit of SSPSTAT is set; SSPIF is set if interrupt on Start detect is enabled.
2. Matching address with R/W bit clear is clocked in. SSPIF is set and CKP cleared after the 8<sup>th</sup> falling edge of SCL.
3. Slave clears the SSPIF.
4. Slave can look at the ACKTIM bit of the SSPCON3 register to determine if the SSPIF was after or before the  $\overline{\text{ACK}}$ .
5. Slave reads the address value from SSPBUF, clearing the BF flag.
6. Slave sets  $\overline{\text{ACK}}$  value clocked out to the master by setting ACKDT.
7. Slave releases the clock by setting CKP.
8. SSPxIF is set after an  $\overline{\text{ACK}}$ , not after a NACK.
9. If SEN = 1 the slave hardware will stretch the clock after the  $\overline{\text{ACK}}$ .
10. Slave clears SSPIF.

**Note:** SSPIF is still set after the 9th falling edge of SCL even if there is no clock stretching and BF has been cleared. Only if NACK is sent to Master is SSPIF not set.

11. SSPIF set and CKP cleared after 8th falling edge of SCL for a received data byte.
12. Slave looks at ACKTIM bit of SSPCON3 to determine the source of the interrupt.
13. Slave reads the received data from SSPBUF clearing BF.
14. Steps 7–14 are the same for each received data byte.
15. Communication is ended by either the slave sending an  $\overline{\text{ACK}} = 1$ , or the master sending a Stop condition. If a Stop is sent and Interrupt on Stop Detect is disabled, the slave will only know by polling the P bit of the SSTSTAT register.

**FIGURE 27-6: I<sup>2</sup>C SLAVE, 7-BIT ADDRESS, RECEPTION (SEN = 0, AHEN = 0, DHEN = 0)**

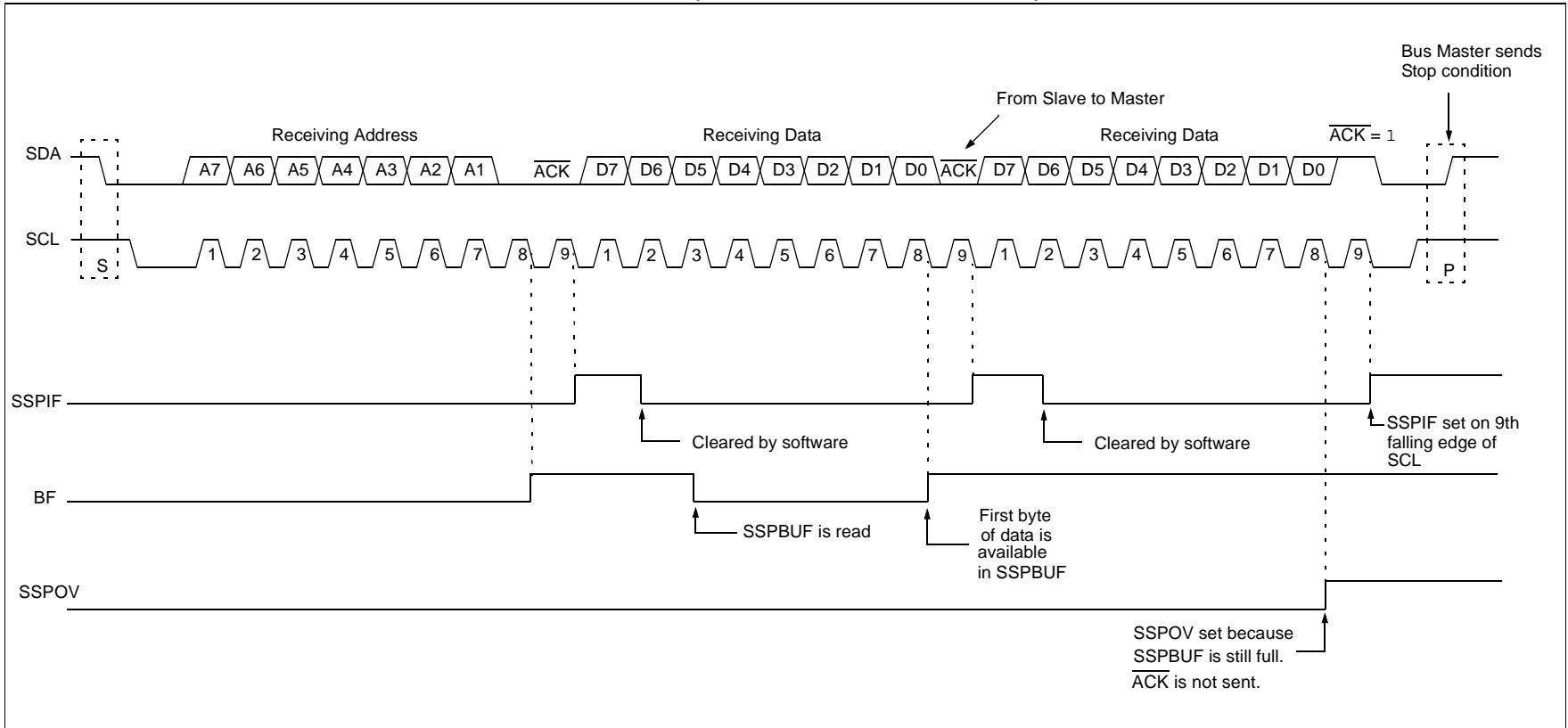
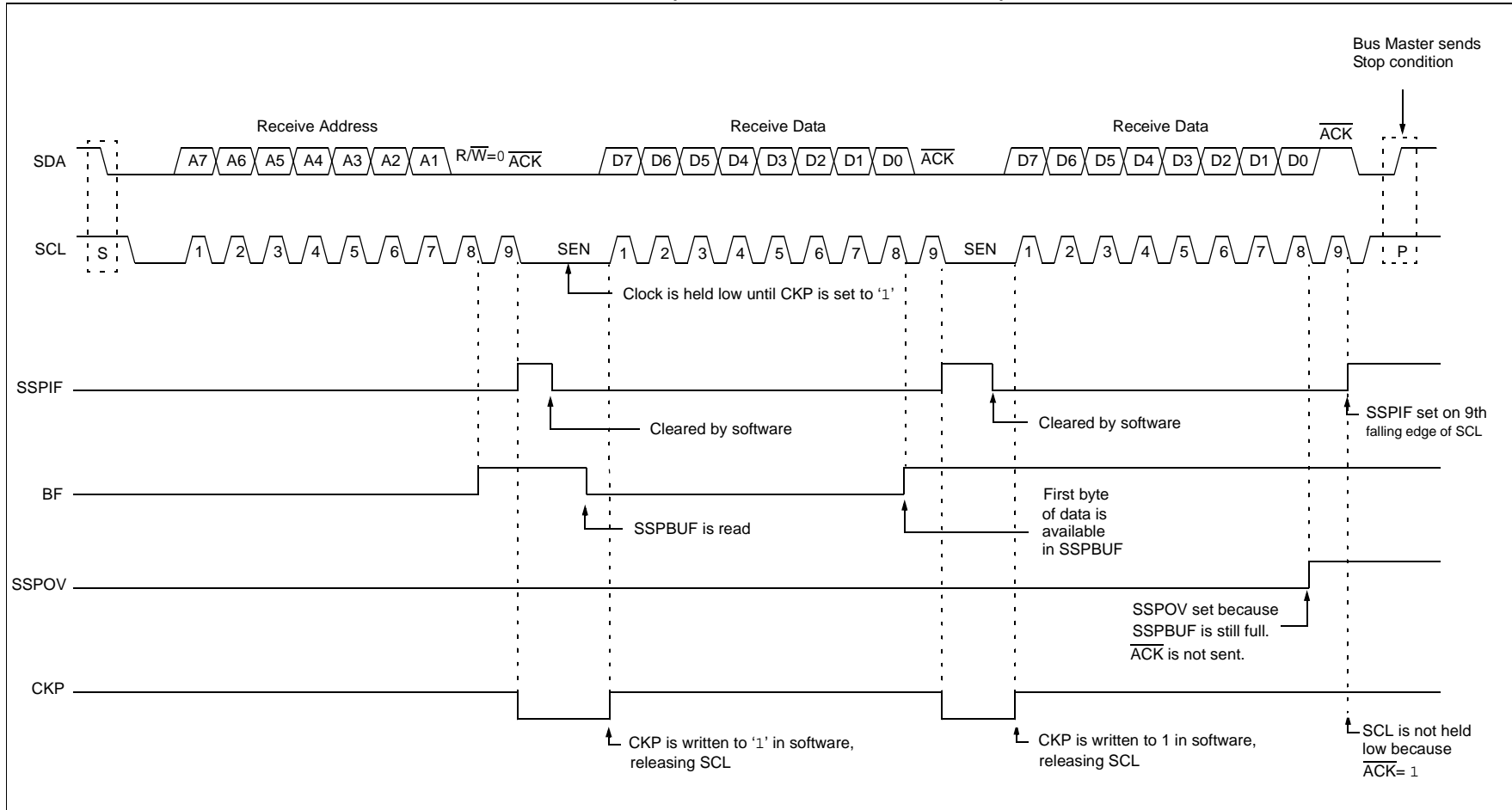
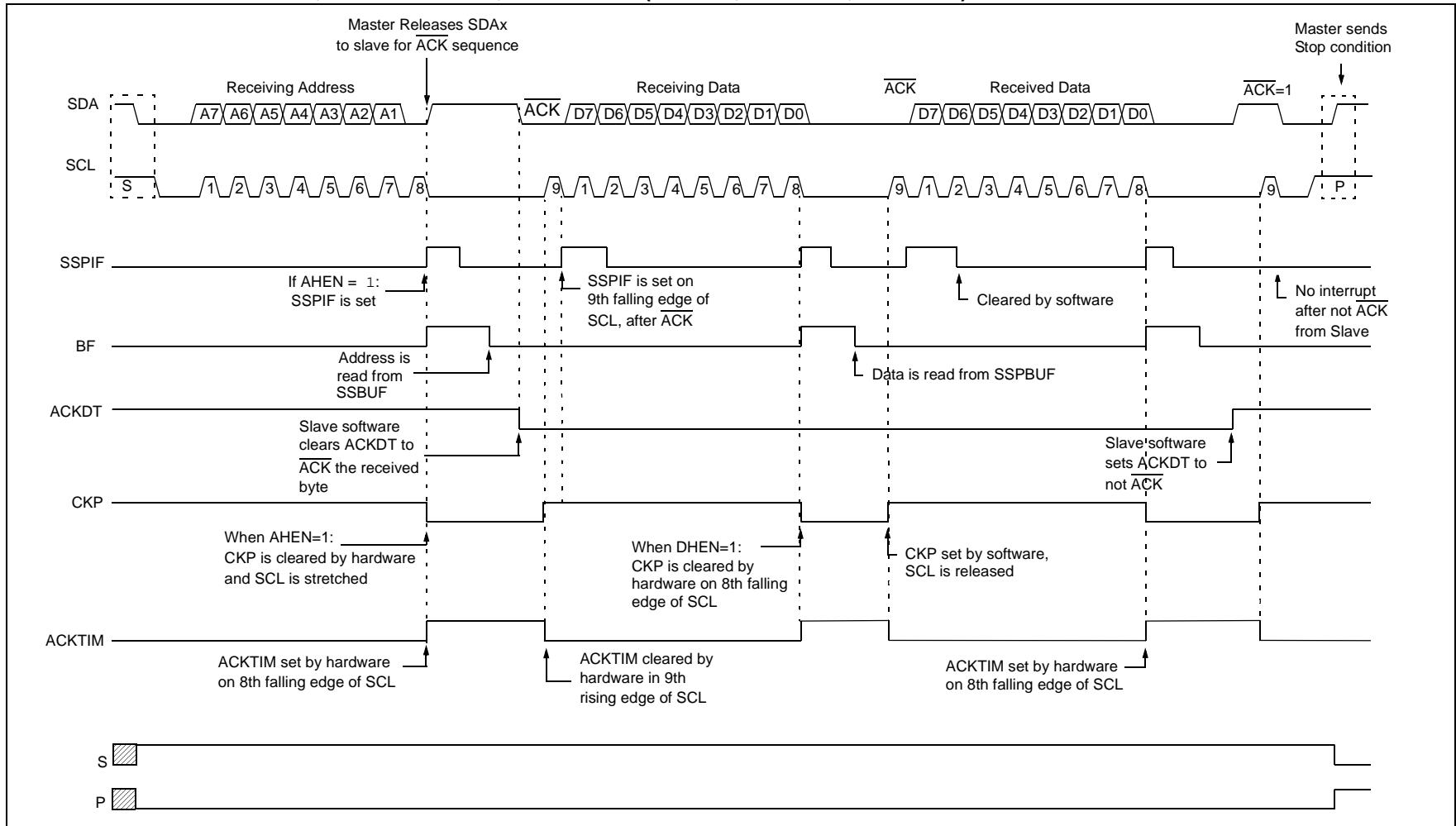

FIGURE 27-7: I<sup>2</sup>C SLAVE, 7-BIT ADDRESS, RECEPTION (SEN = 1, AHEN = 0, DHEN = 0)



**FIGURE 27-8: I<sup>2</sup>C SLAVE, 7-BIT ADDRESS, RECEPTION (SEN = 0, AHEN = 1, DHEN = 1)**



**FIGURE 27-9: I<sup>2</sup>C SLAVE, 7-BIT ADDRESS, RECEPTION (SEN = 1, AHEN = 1, DHEN = 1)**

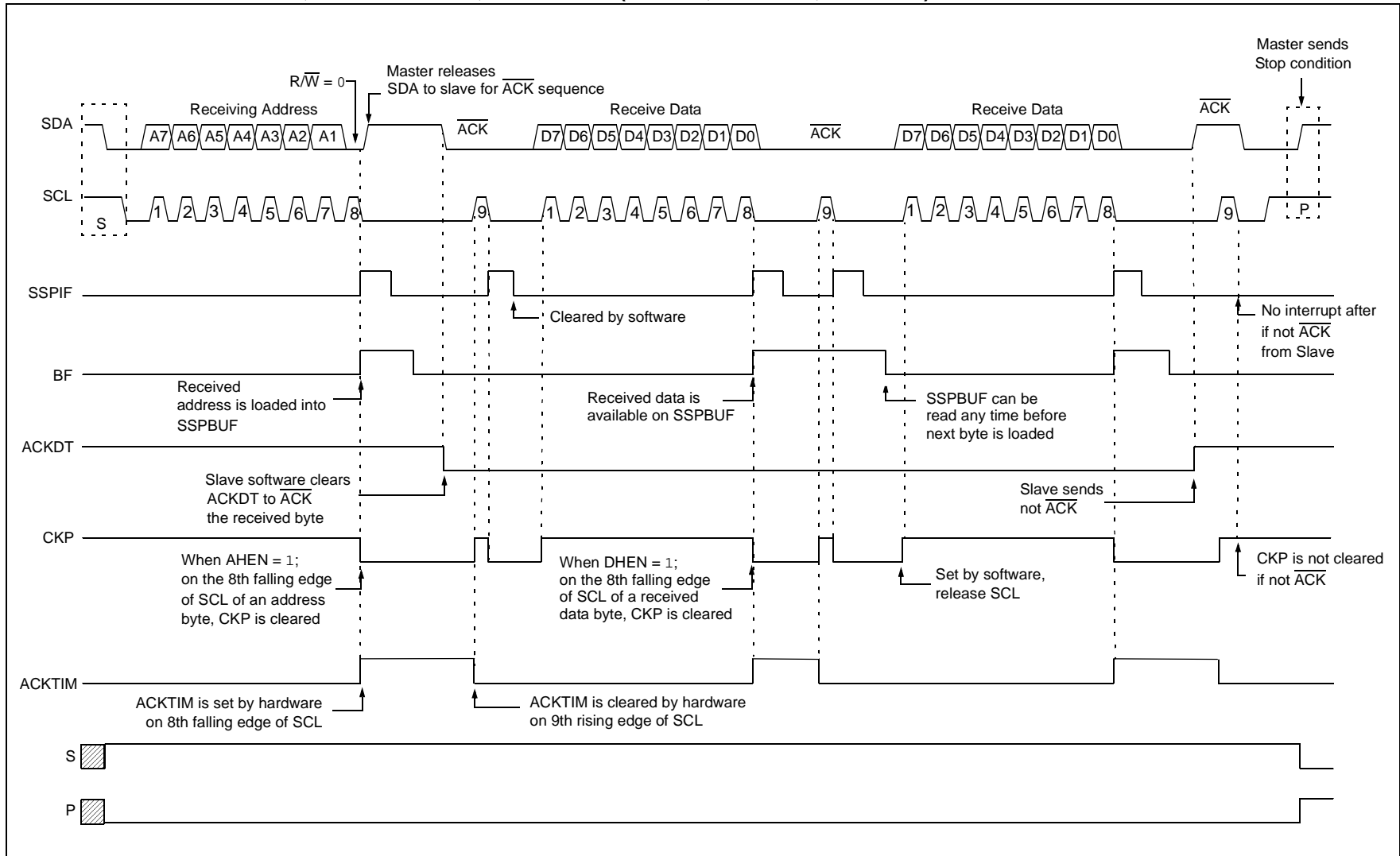

#### 27.4.4 SLAVE TRANSMISSION

When the  $\overline{R/W}$  bit of the incoming address byte is set and an address match occurs, the  $\overline{R/W}$  bit of the SSPSTAT register is set. The received address is loaded into the SSPBUF register, and an  $\overline{ACK}$  pulse is sent by the slave on the ninth bit.

Following the  $\overline{ACK}$ , slave hardware clears the CKP bit and the SCL pin is held low (see [Section 27.4.7 “Clock Stretching”](#) for more detail). By stretching the clock, the master will be unable to assert another clock pulse until the slave is done preparing the transmit data.

The transmit data must be loaded into the SSPBUF register which also loads the SSPSR register. Then the SCL pin should be released by setting the CKP bit of the SSPCON1 register. The eight data bits are shifted out on the falling edge of the SCL input. This ensures that the SDA signal is valid during the SCL high time.

The  $\overline{ACK}$  pulse from the master-receiver is latched on the rising edge of the ninth SCL input pulse. This  $\overline{ACK}$  value is copied to the ACKSTAT bit of the SSPCON2 register. If ACKSTAT is set (not  $\overline{ACK}$ ), then the data transfer is complete. In this case, when the not  $\overline{ACK}$  is latched by the slave, the slave goes Idle and waits for another occurrence of the Start bit. If the SDA line was low ( $\overline{ACK}$ ), the next transmit data must be loaded into the SSPBUF register. Again, the SCL pin must be released by setting bit CKP.

An MSSP interrupt is generated for each data transfer byte. The SSPIF bit must be cleared by software and the SSPSTAT register is used to determine the status of the byte. The SSPIF bit is set on the falling edge of the ninth clock pulse.

##### 27.4.4.1 Slave Mode Bus Collision

A slave receives a Read request and begins shifting data out on the SDA line. If a bus collision is detected and the SBCDE bit of the SSPCON3 register is set, the BCLIF bit of the PIR register is set. Once a bus collision is detected, the slave goes Idle and waits to be addressed again. User software can use the BCLIF bit to handle a slave bus collision.

##### 27.4.4.2 7-bit Transmission

A master device can transmit a read request to a slave, and then clock data out of the slave. The list below outlines what software for a slave will need to do to accomplish a standard transmission. [Figure 27-10](#) can be used as a reference to this list.

1. Master sends a Start condition on SDA and SCL.
2. S bit of SSPSTAT is set; SSPIF is set if interrupt on Start detect is enabled.
3. Matching address with  $\overline{R/W}$  bit set is received by the Slave setting SSPIF bit.
4. Slave hardware generates an  $\overline{ACK}$  and sets SSPIF.
5. SSPIF bit is cleared by user.
6. Software reads the received address from SSPBUF, clearing BF.
7.  $\overline{R/W}$  is set so CKP was automatically cleared after the  $\overline{ACK}$ .
8. The slave software loads the transmit data into SSPBUF.
9. CKP bit is set releasing SCL, allowing the master to clock the data out of the slave.
10. SSPIF is set after the  $\overline{ACK}$  response from the master is loaded into the ACKSTAT register.
11. SSPIF bit is cleared.
12. The slave software checks the ACKSTAT bit to see if the master wants to clock out more data.

**Note 1:** If the master  $\overline{ACK}$ s the clock will be stretched.

**2:** ACKSTAT is the only bit updated on the rising edge of SCL (9th) rather than the falling.

13. Steps 9-13 are repeated for each transmitted byte.
14. If the master sends a not  $\overline{ACK}$ ; the clock is not held, but SSPIF is still set.
15. The master sends a Restart condition or a Stop.
16. The slave is no longer addressed.

**FIGURE 27-10: I<sup>2</sup>C SLAVE, 7-BIT ADDRESS, TRANSMISSION (AHEN = 0)**

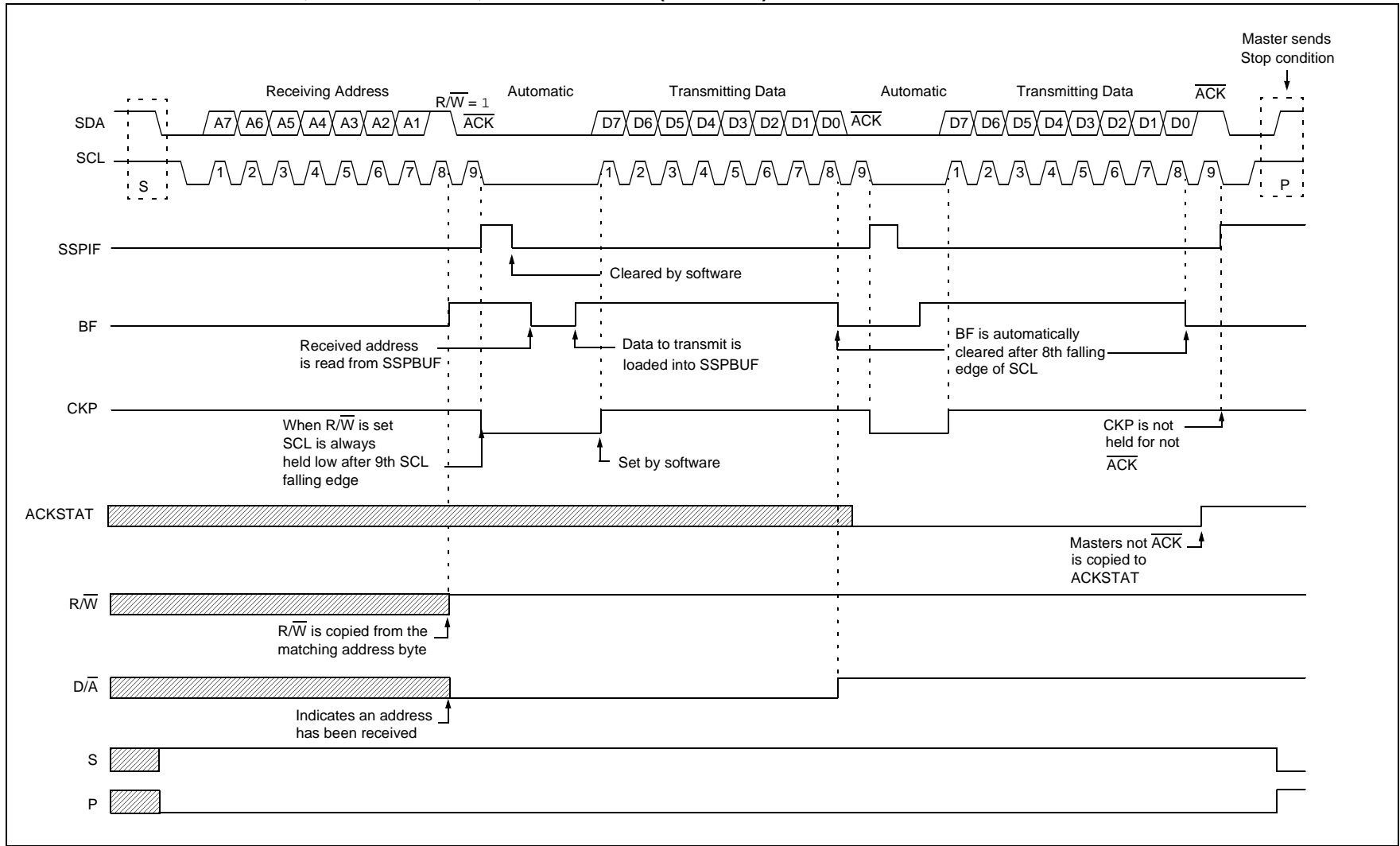



### 27.4.4.3 7-bit Transmission with Address Hold Enabled

Setting the AHEN bit of the SSPCON3 register enables additional clock stretching and interrupt generation after the 8<sup>th</sup> falling edge of a received matching address. Once a matching address has been clocked in, CKP is cleared and the SSPIF interrupt is set.

Figure 27-11 displays a standard waveform of a 7-bit Address Slave Transmission with AHEN enabled.

1. Bus starts Idle.
2. Master sends Start condition; the S bit of SSPSTAT is set; SSPIF is set if interrupt on Start detect is enabled.
3. Master sends matching address with  $\overline{R/W}$  bit set. After the 8<sup>th</sup> falling edge of the SCL line, the CKP bit is cleared and SSPIF interrupt is generated.
4. Slave software clears SSPIF.
5. Slave software reads ACKTIM bit of SSPCON3 register, and  $\overline{R/W}$  and  $\overline{D/A}$  of the SSPSTAT register to determine the source of the interrupt.
6. Slave reads the address value from the SSPBUF register clearing the BF bit.
7. Slave software decides from this information if it wishes to ACK or not ACK and sets ACKDT bit of the SSPCON2 register accordingly.
8. Slave sets the CKP bit releasing SCL.
9. Master clocks in the  $\overline{ACK}$  value from the slave.
10. Slave hardware automatically clears the CKP bit and sets SSPIF after the ACK if the  $\overline{R/W}$  bit is set.
11. Slave software clears SSPIF.
12. Slave loads value to transmit to the master into SSPBUF setting the BF bit.

**Note:** SSPBUF cannot be loaded until after the  $\overline{ACK}$ .

13. Slave sets CKP bit releasing the clock.
14. Master clocks out the data from the slave and sends an  $\overline{ACK}$  value on the 9<sup>th</sup> SCL pulse.
15. Slave hardware copies the  $\overline{ACK}$  value into the ACKSTAT bit of the SSPCON2 register.
16. Steps 10–15 are repeated for each byte transmitted to the master from the slave.
17. If the master sends a not  $\overline{ACK}$ , the slave releases the bus, allowing the master to send a Stop and end the communication.

**Note:** Master must send a not  $\overline{ACK}$  on the last byte to ensure that the slave releases the SCL line to receive a Stop.

**FIGURE 27-11: I<sup>2</sup>C SLAVE, 7-BIT ADDRESS, TRANSMISSION (AHEN = 1)**

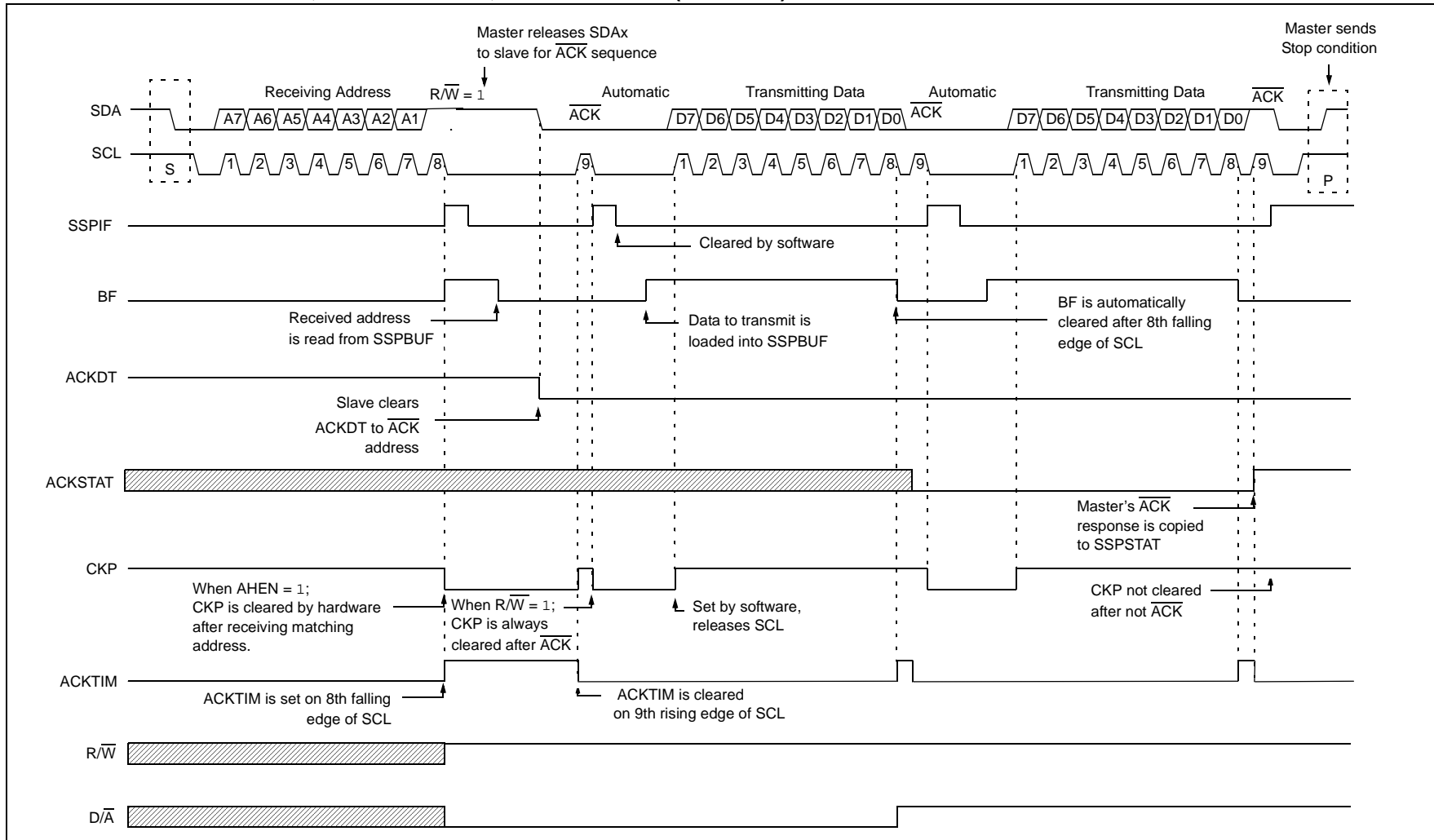

## 27.4.5 SLAVE MODE 10-BIT ADDRESS RECEPTION

This section describes a standard sequence of events for the MSSP module configured as an I<sup>2</sup>C Slave in 10-bit Addressing mode.

Figure 27-12 is used as a visual reference for this description.

This is a step-by-step process of what must be done by slave software to accomplish I<sup>2</sup>C communication.

1. Bus starts Idle.
2. Master sends Start condition; S bit of SSPSTAT is set; SSPIF is set, if interrupt on Start detect is enabled.
3. Master sends matching high address with R/W bit clear; UA bit of the SSPSTAT register is set.
4. Slave sends  $\overline{\text{ACK}}$  and SSPIF is set.
5. Software clears the SSPIF bit.
6. Software reads received address from SSPBUF clearing the BF flag.
7. Slave loads low address into SSPADDx, releasing SCL.
8. Master sends matching low-address byte to the Slave; UA bit is set.

**Note:** Updates to the SSPADDx register are not allowed until after the  $\overline{\text{ACK}}$  sequence.

9. Slave sends  $\overline{\text{ACK}}$  and SSPIF is set.

**Note:** If the low address does not match, SSPIF and UA are still set so that the slave software can set SSPADDx back to the high address. BF is not set because there is no match. CKP is unaffected.

10. Slave clears SSPIF.
11. Slave reads the received matching address from SSPBUF clearing BF.
12. Slave loads high address into SSPADD.
13. Master clocks a data byte to the slave and clocks out the slave's  $\overline{\text{ACK}}$  on the 9th SCL pulse; SSPIF is set.
14. If SEN bit of SSPCON2 is set, CKP is cleared by hardware and the clock is stretched.
15. Slave clears SSPIF.
16. Slave reads the received byte from SSPBUF clearing BF.
17. If SEN is set, the slave sets CKP to release the SCL.
18. Steps 13–17 repeat for each received byte.
19. Master sends Stop to end the transmission.

## 27.4.6 10-BIT ADDRESSING WITH ADDRESS OR DATA HOLD

Reception using 10-bit addressing with AHEN or DHEN set is the same as with 7-bit modes. The only difference is the need to update the SSPADDx register using the UA bit. All functionality, specifically when the CKP bit is cleared and SCL line is held low, are the same.

Figure 27-13 can be used as a reference of a slave in 10-bit addressing with AHEN set.

Figure 27-14 shows a standard waveform for a slave transmitter in 10-bit Addressing mode.

FIGURE 27-12: I<sup>2</sup>C SLAVE, 10-BIT ADDRESS, RECEPTION (SEN = 1, AHEN = 0, DHEN = 0)

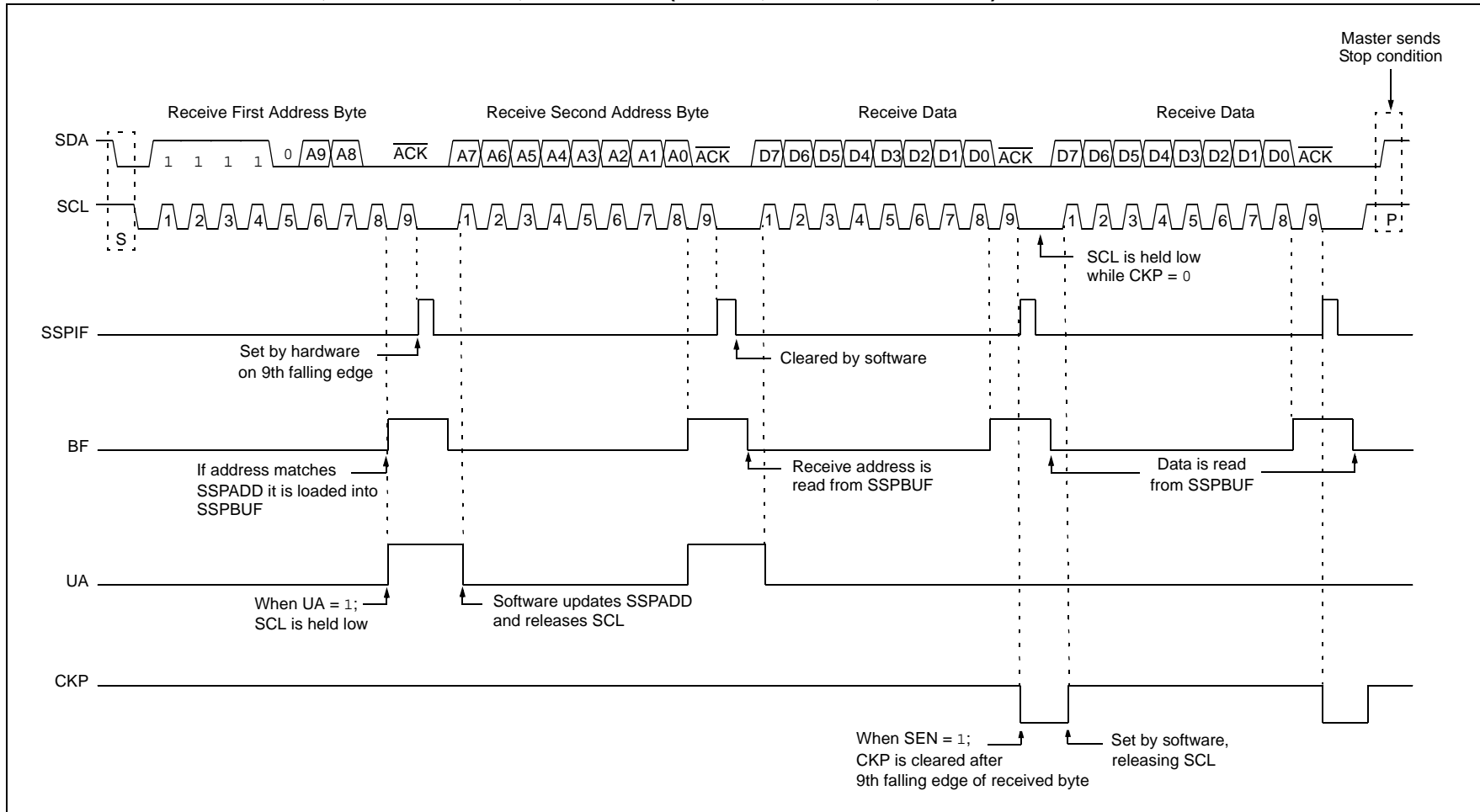

**FIGURE 27-13: I<sup>2</sup>C SLAVE, 10-BIT ADDRESS, RECEPTION (SEN = 0, AHEN = 1, DHEN = 0)**

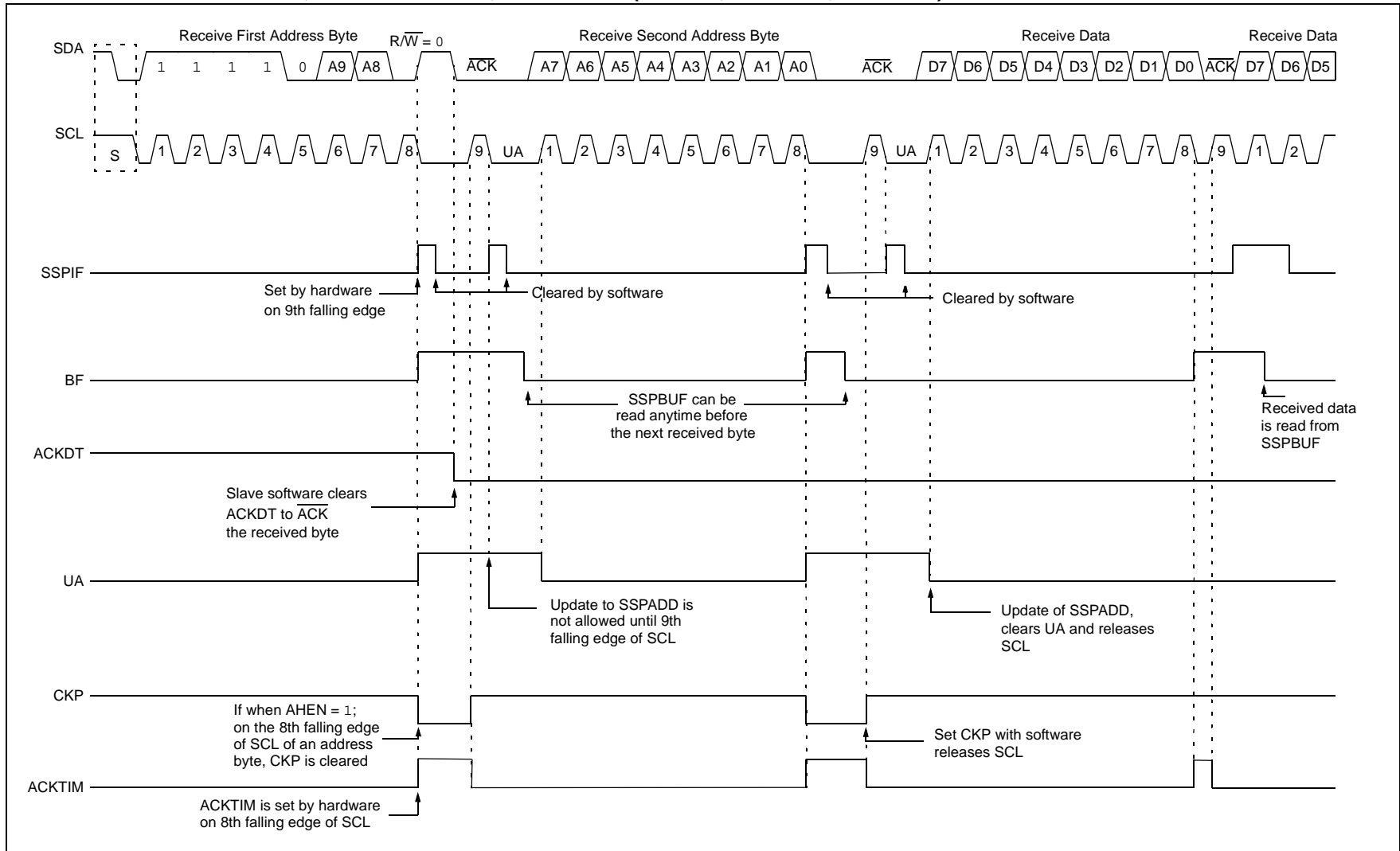

**FIGURE 27-14: I<sup>2</sup>C SLAVE, 10-BIT ADDRESS, TRANSMISSION (SEN = 0, AHEN = 0, DHEN = 0)**

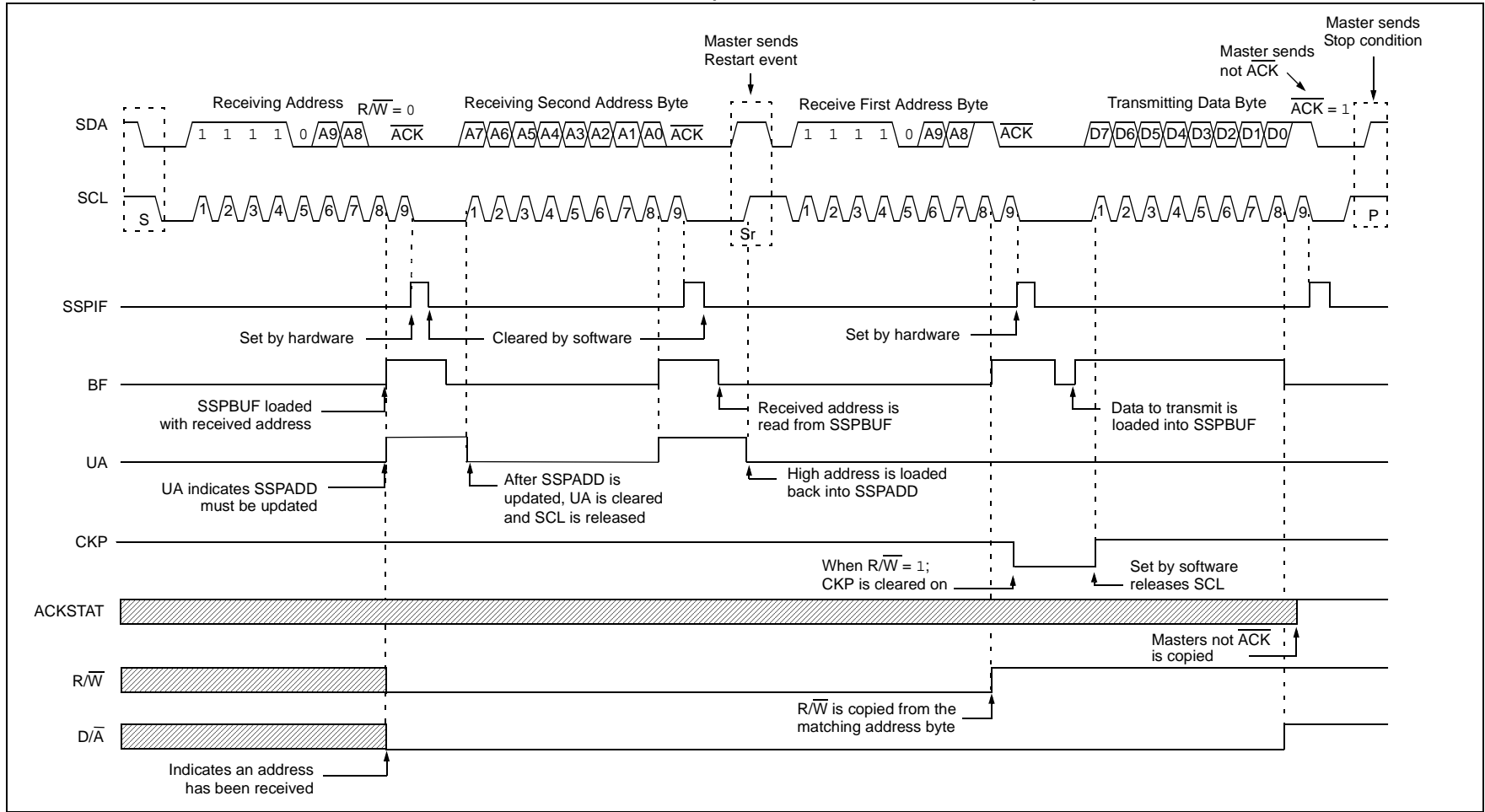

## 27.4.7 CLOCK STRETCHING

Clock stretching occurs when a device on the bus holds the SCL line low, effectively pausing communication. The slave may stretch the clock to allow more time to handle data or prepare a response for the master device. A master device is not concerned with stretching, as anytime it is active on the bus and not transferring data, it is stretching. Any stretching done by a slave is invisible to the master software and handled by the hardware that generates SCL.

The CKP bit of the SSPCON1 register is used to control stretching in software. Any time the CKP bit is cleared, the module will wait for the SCL line to go low and then hold it. Setting CKP will release SCL and allow more communication.

### 27.4.7.1 Normal Clock Stretching

Following an  $\overline{\text{ACK}}$ , if the  $\overline{\text{R/W}}$  bit of the SSPSTAT is set, causing a read request, the slave hardware will clear CKP. This allows the slave time to update SSPBUF with data to transfer to the master. If the SEN bit of SSPCON2 is set, the slave hardware will always stretch the clock after the ACK sequence. Once the slave is ready; CKP is set by software and communication resumes.

**Note 1:** The BF bit has no effect on if the clock will be stretched or not. This is different than previous versions of the module that would not stretch the clock or clear CKP, if SSPBUF was read before the 9<sup>th</sup> falling edge of SCL.

**2:** Previous versions of the module did not stretch the clock for a transmission if SSPBUF was loaded before the 9<sup>th</sup> falling edge of SCL. It is now always cleared for read requests.

### 27.4.7.2 10-bit Addressing Mode

In 10-bit Addressing mode, when the UA bit is set, the clock is always stretched. This is the only time the SCL is stretched without CKP being cleared. SCL is released immediately after a write to SSPADDx.

**Note:** Previous versions of the module did not stretch the clock if the second address byte did not match.

### 27.4.7.3 Byte NACKing

When AHEN bit of SSPCON3 is set; CKP is cleared by the hardware after the 8<sup>th</sup> falling edge of SCL for a received matching address byte. When DHEN bit of SSPCON3 is set; CKP is cleared after the 8<sup>th</sup> falling edge of SCL for received data.

Stretching after the 8<sup>th</sup> falling edge of SCL allows the slave to look at the received address or data and decide if it wants to ACK the received data.

## 27.4.8 CLOCK SYNCHRONIZATION AND THE CKP BIT

Any time the CKP bit is cleared, the module will wait for the SCL line to go low and then hold it. However, clearing the CKP bit will not assert the SCL output low until the SCL output is already sampled low. Therefore, the CKP bit will not assert the SCL line until an external I<sup>2</sup>C master device has already asserted the SCL line. The SCL output will remain low until the CKP bit is set and all other devices on the I<sup>2</sup>C bus have released SCL. This ensures that a write to the CKP bit will not violate the minimum high time requirement for SCL (see Figure 27-15).

**FIGURE 27-15: CLOCK SYNCHRONIZATION TIMING**

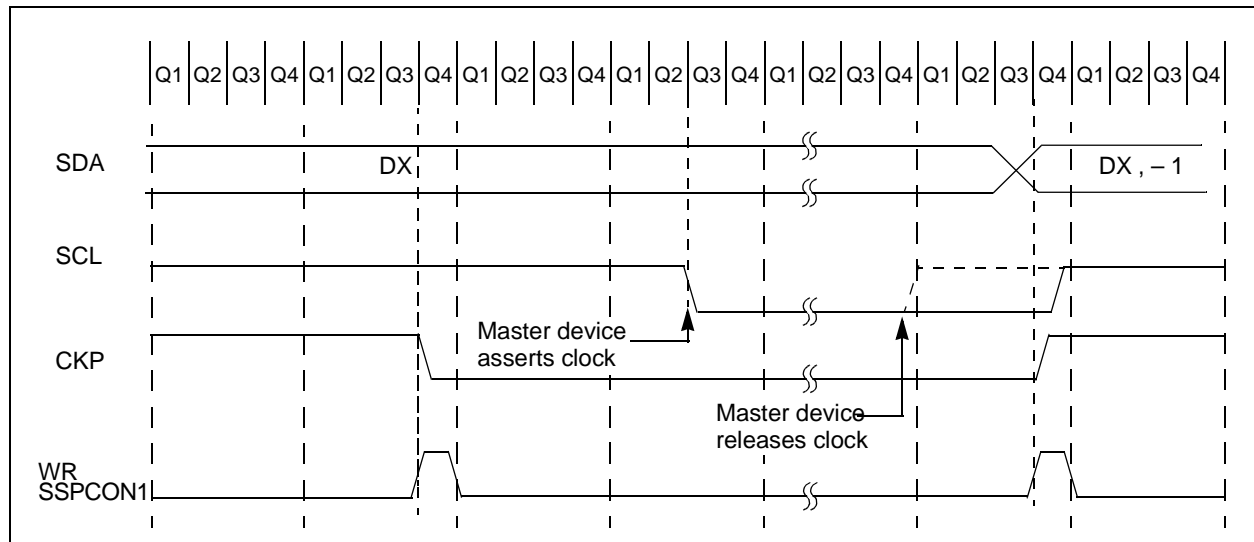

# MCP19110/11

## 27.4.9 GENERAL CALL ADDRESS SUPPORT

The addressing procedure for the I<sup>2</sup>C bus is such that the first byte after the Start condition usually determines which device will be the slave addressed by the master device. The exception is the general call address, which can address all devices. When this address is used, all devices should, in theory, respond with an acknowledge.

The general call address is a reserved address in the I<sup>2</sup>C protocol, defined as address 0x00. When the GCEN bit of the SSPCON2 register is set, the slave module will automatically  $\overline{\text{ACK}}$  the reception of this address, regardless of the value stored in SSPADDx. After the slave clocks in an address of all zeros with the R/W bit clear, an interrupt is generated and slave software can read SSPBUF and respond. Figure 27-16 shows a general call reception sequence.

In 10-bit Address mode, the UA bit will not be set on the reception of the general call address. The slave will prepare to receive the second byte as data, just as it would in the 7-bit mode.

If the AHEN bit of the SSPCON3 register is set, just as with any other address reception, the slave hardware will stretch the clock after the 8<sup>th</sup> falling edge of SCL. The slave must then set its ACKDT value and release the clock with communication progressing as it would normally.

**FIGURE 27-16: SLAVE MODE GENERAL CALL ADDRESS SEQUENCE**

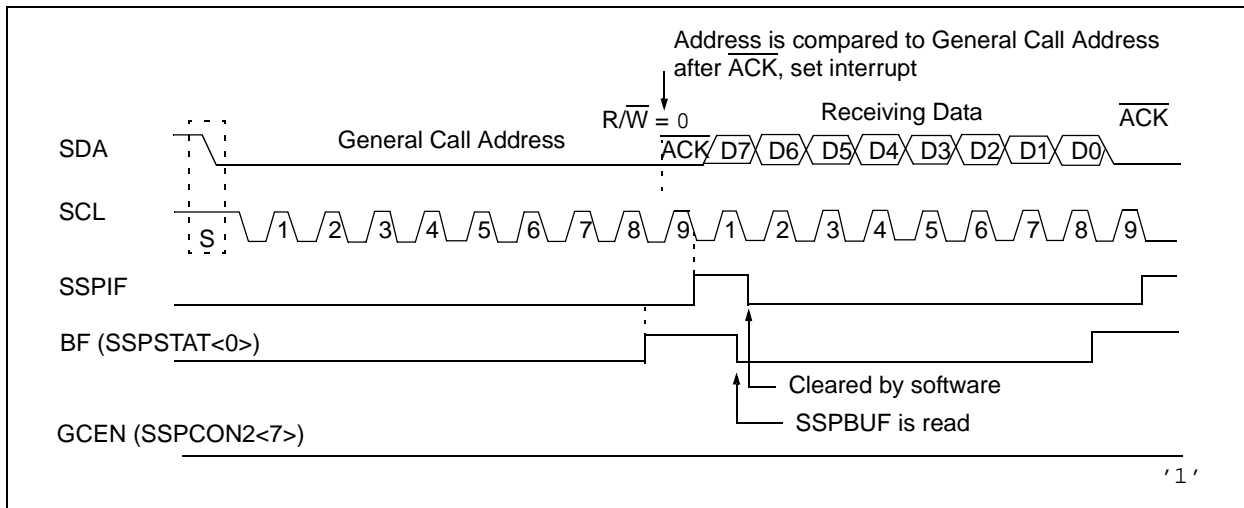

## 27.4.10 SSPMSKX REGISTER

An SSP Mask (SSPMSKx) register (Register 27-6 and Register 27-8) is available in I<sup>2</sup>C Slave mode as a mask for the value held in the SSPSRx register during an address comparison operation. A zero ('0') bit in the SSPMSKx register has the effect of making the corresponding bit of the received address a "don't care".

This register is reset to all '1's upon any Reset condition and, therefore, has no effect on standard SSP operation until written with a mask value.

The SSP Mask register is active during:

- 7-bit Address mode: address compare of A<7:1>.
- 10-bit Address mode: address compare of A<7:0> only. The SSP mask has no effect during the reception of the first (high) byte of the address.



## 27.5 I<sup>2</sup>C Master Mode

Master mode is enabled by setting and clearing the appropriate SSPM bits in the SSPCON1 register and by setting the SSPEN bit. In Master mode, the SDA and SCK pins must be configured as inputs. The MSSP peripheral hardware will override the output driver TRIS controls when necessary, to drive the pins low.

Master mode of operation is supported by interrupt generation on the detection of the Start and Stop conditions. The Stop (P) and Start (S) bits are cleared from a Reset or when the MSSP module is disabled. Control of the I<sup>2</sup>C bus may be taken when the P bit is set, or the bus is Idle.

In Firmware Controlled Master mode, user code conducts all I<sup>2</sup>C bus operations based on Start and Stop bit condition detection. Start and Stop condition detection is the only active circuitry in this mode. All other communication is done by the user software directly manipulating the SDA and SCL lines.

The following events will cause the SSP Interrupt Flag bit, SSPIF, to be set (SSP interrupt, if enabled):

- Start condition detected
- Stop condition detected
- Data transfer byte transmitted/received
- Acknowledge transmitted/received
- Repeated Start generated

**Note 1:** The MSSP module, when configured in I<sup>2</sup>C Master mode, does not allow queuing of events. For instance, the user is not allowed to initiate a Start condition and immediately write the SSPBUF register to initiate transmission before the Start condition is complete. In this case, the SSPBUF will not be written to and the WCOL bit will be set, indicating that a write to the SSPBUF did not occur.

- 2:** When in Master mode, Start/Stop detection is masked and an interrupt is generated when the SEN/PEN bit is cleared and the generation is complete.

### 27.5.1 I<sup>2</sup>C MASTER MODE OPERATION

The master device generates all of the serial clock pulses and the Start and Stop conditions. A transfer is ended with a Stop condition or with a Repeated Start condition. Since the Repeated Start condition is also the beginning of the next serial transfer, the I<sup>2</sup>C bus will not be released.

In Master Transmitter mode, serial data is output through SDA, while SCL outputs the serial clock. The first byte transmitted contains the slave address of the receiving device (7 bits) and the Read/Write (R/W) bit. In this case, the R/W bit will be logic '0'. Serial data is transmitted eight bits at a time. After each byte is transmitted, an Acknowledge bit is received. Start and Stop conditions are output to indicate the beginning and the end of a serial transfer.

In Master Receive mode, the first byte transmitted contains the slave address of the transmitting device (7 bits) and the R/W bit. In this case, the R/W bit will be logic '1'. Thus, the first byte transmitted is a 7-bit slave address followed by a '1' to indicate the receive bit. Serial data is received via SDA, while SCL outputs the serial clock. Serial data is received eight bits at a time. After each byte is received, an Acknowledge bit is transmitted. Start and Stop conditions indicate the beginning and the end of transmission.

A Baud Rate Generator is used to set the clock frequency output on SCL. See [Section 27.6 “Baud Rate Generator”](#) for more detail.

### 27.5.2 CLOCK ARBITRATION

Clock arbitration occurs when the master, during any receive, transmit or Repeated Start/Stop condition, releases the SCL pin (SCL allowed to float high). When the SCL pin is allowed to float high, the Baud Rate Generator (BRG) is suspended from counting until the SCL pin is actually sampled high. When the SCL pin is sampled high, the Baud Rate Generator is reloaded with the contents of SSPADD<7:0> and begins counting. This ensures that the SCL high time will always be at least one BRG rollover count in the event that the clock is held low by an external device ([Figure 27-17](#)).

# MCP19110/11

**FIGURE 27-17: BAUD RATE GENERATOR TIMING WITH CLOCK ARBITRATION**

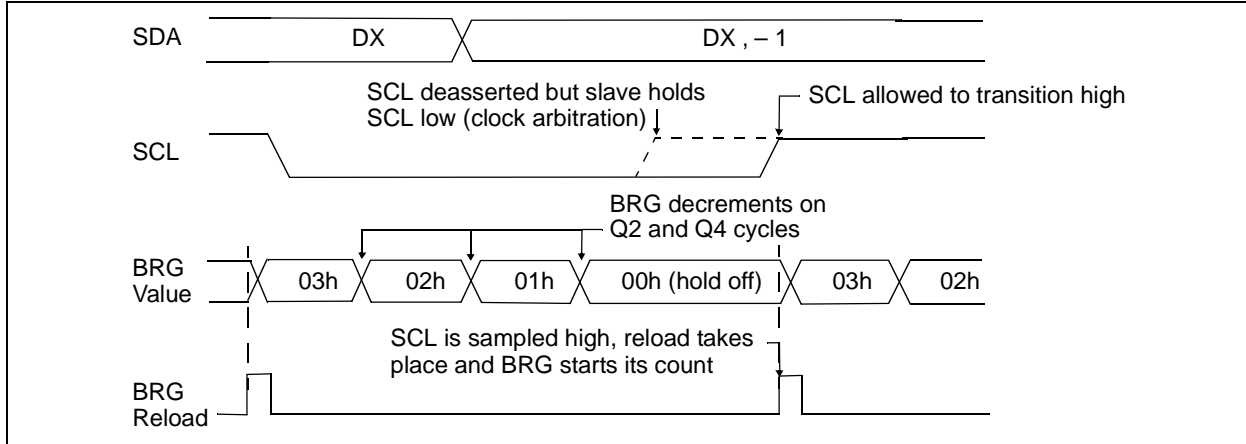

### 27.5.3 WCOL STATUS FLAG

If the user writes the SSPBUF when a Start, Restart, Stop, Receive or Transmit sequence is in progress, the WCOL is set and the contents of the buffer are unchanged (the write does not occur). Any time the WCOL bit is set, it indicates that an action on SSPBUF was attempted while the module was not Idle.

**Note:** Because queuing of events is not allowed, writing to the lower five bits of SSPCON2 is disabled until the Start condition is complete.

### 27.5.4 I<sup>2</sup>C MASTER MODE START CONDITION TIMING

To initiate a Start condition, the user sets the Start Enable bit, SEN bit of the SSPCON2 register. If the SDA and SCL pins are sampled high, the Baud Rate Generator is reloaded with the contents of SSPADD<7:0> and starts its count. If SCL and SDA are both sampled high when the Baud Rate Generator times out ( $T_{BRG}$ ), the SDA pin is driven low. The action

of the SDA being driven low while SCL is high is the Start condition and causes the S bit of the SSPSTAT register to be set. Following this, the Baud Rate Generator is reloaded with the contents of SSPADD<7:0> and resumes its count. When the Baud Rate Generator times out ( $T_{BRG}$ ), the SEN bit of the SSPCON2 register will be automatically cleared by hardware; the Baud Rate Generator is suspended, leaving the SDA line held low and the Start condition is complete.

**Note 1:** If at the beginning of the Start condition, the SDA and SCL pins are already sampled low, or if during the Start condition, the SCL line is sampled low before the SDA line is driven low, a bus collision occurs, the Bus Collision Interrupt Flag, BCLIF, is set, the Start condition is aborted and the I<sup>2</sup>C module is reset into its Idle state.

**2:** The Philips I<sup>2</sup>C Specification states that a bus collision cannot occur on a Start.

**FIGURE 27-18: FIRST START BIT TIMING**

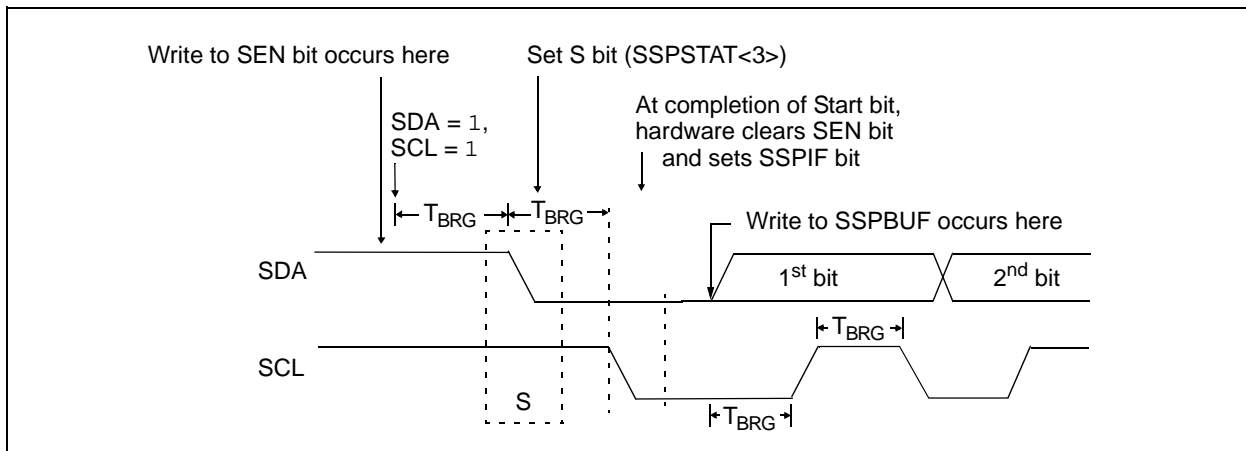

## 27.5.5 I<sup>2</sup>C MASTER MODE REPEATED START CONDITION TIMING

A Repeated Start condition occurs when the RSEN bit of the SSPCON2 register is programmed high and the Master state machine is no longer active. When the RSEN bit is set, the SCL pin is asserted low. When the SCL pin is sampled low, the Baud Rate Generator is loaded and begins counting. The SDA pin is released (brought high) for one Baud Rate Generator count ( $T_{BRG}$ ). When the Baud Rate Generator times out, if SDA is sampled high, the SCL pin will be deasserted (brought high). When SCL is sampled high, the Baud Rate Generator is reloaded and begins counting. SDA and SCL must be sampled high for one  $T_{BRG}$ . This action is then followed by the assertion of the SDA pin ( $SDA = 0$ ) for one  $T_{BRG}$  while SCL is high. SCL is asserted low. Following this, the RSEN bit of the SSPCON2 register will be automatically cleared and the Baud Rate Generator will not be reloaded, leaving the SDA pin held low. As soon as a Start condition is detected on the SDA and SCL pins, the S bit of the SSPSTAT register will be set. The SSPIF bit will not be set until the Baud Rate Generator has timed out.

**Note 1:** If RSEN is programmed while any other event is in progress, it will not take effect.

**2:** A bus collision during the Repeated Start condition occurs if:

- SDA is sampled low when SCL goes from low-to-high.
- SCL goes low before SDA is asserted low. This may indicate that another master is attempting to transmit a data '1'.

**FIGURE 27-19: REPEAT START CONDITION WAVEFORM**

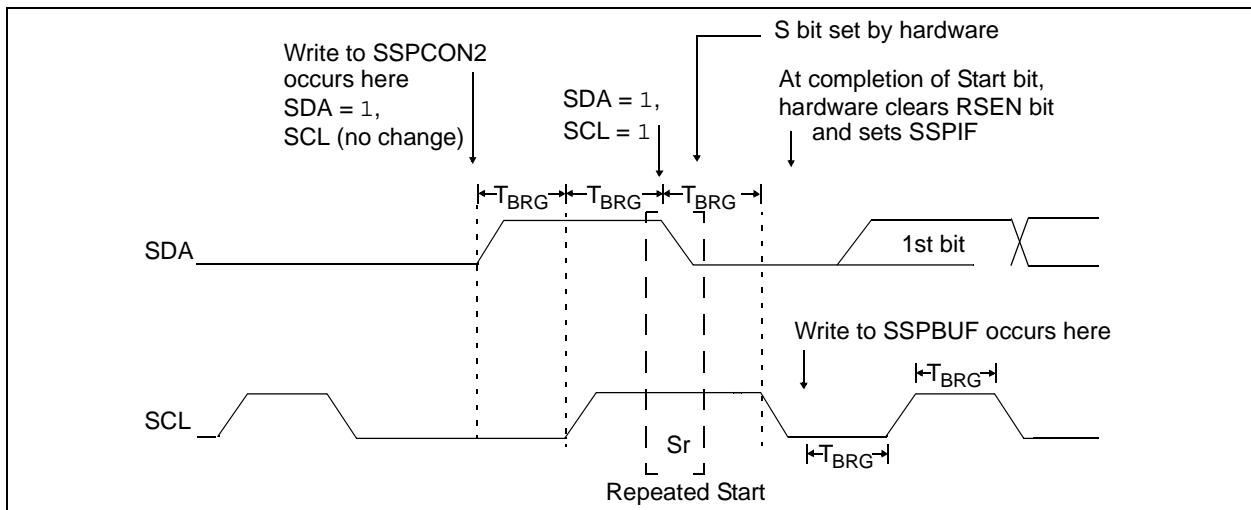

## 27.5.6 I<sup>2</sup>C MASTER MODE TRANSMISSION

Transmission of a data byte, a 7-bit address or the other half of a 10-bit address is accomplished by simply writing a value to the SSPBUF register. This action will set the Buffer Full flag bit, BF, and will allow the Baud Rate Generator to begin counting and start the next transmission. Each bit of address/data will be shifted out onto the SDA pin after the falling edge of SCL is asserted. SCL is held low for one Baud Rate Generator rollover count ( $T_{BRG}$ ). Data should be valid before SCL is released high. When the SCL pin is released high, it is held that way for  $T_{BRG}$ . The data on the SDA pin must remain stable for that duration and some hold time after the next falling edge of SCL. After the 8<sup>th</sup> bit is shifted out (the falling edge of the 8<sup>th</sup> clock), the BF flag is cleared and the master releases the SDA. This allows the slave device being addressed to respond with an  $\overline{ACK}$  bit during the 9<sup>th</sup> bit time if an address match occurred, or if data was received properly. The status of  $\overline{ACK}$  is written into the ACKSTAT bit on the rising edge of the 9<sup>th</sup> clock. If the master receives an Acknowledge, the Acknowledge Status bit, ACKSTAT, is cleared. If not, the bit is set. After the 9<sup>th</sup> clock, the SSPIF bit is set and the master clock (Baud Rate Generator) is suspended until the next data byte is loaded into the SSPBUF, leaving SCL low and SDA unchanged (Figure 27-20).

After the write to the SSPBUF, each bit of the address will be shifted out on the falling edge of SCL until all seven address bits and the R/W bit are completed. On the falling edge of the 8<sup>th</sup> clock, the master will release the SDA pin, allowing the slave to respond with an Acknowledge. On the falling edge of the 9<sup>th</sup> clock, the master will sample the SDA pin to see if the address was recognized by a slave. The status of the  $\overline{ACK}$  bit is loaded into the ACKSTAT Status bit of the SSPCON2 register. Following the falling edge of the 9<sup>th</sup> clock transmission of the address, the SSPIF is set, the BF flag is cleared and the Baud Rate Generator is turned off until another write to the SSPBUF takes place, holding SCL low and allowing SDA to float.

### 27.5.6.1 BF Status Flag

In Transmit mode, the BF bit of the SSPSTAT register is set when the CPU writes to SSPBUF, and is cleared when all eight bits are shifted out.

### 27.5.6.2 WCOL Status Flag

If the user writes the SSPBUF when a transmit is already in progress (i.e., SSPSR is still shifting out a data byte), the WCOL is set and the contents of the buffer are unchanged (the write does not occur).

WCOL must be cleared by software before the next transmission.

### 27.5.6.3 ACKSTAT Status Flag

In Transmit mode, the ACKSTAT bit of the SSPCON2 register is cleared when the slave has sent an Acknowledge ( $\overline{ACK} = 0$ ) and is set when the slave does not Acknowledge ( $\overline{ACK} = 1$ ). A slave sends an Acknowledge when it has recognized its address (including a general call), or when the slave has properly received its data.

### 27.5.6.4 Typical transmit sequence

1. The user generates a Start condition by setting the SEN bit of the SSPCON2 register.
2. SSPIF is set by hardware on completion of the Start.
3. SSPIF is cleared by software.
4. The MSSP module will wait the required start time before any other operation takes place.
5. The user loads the SSPBUF with the slave address to transmit.
6. Address is shifted out the SDA pin until all eight bits are transmitted. Transmission begins as soon as SSPBUF is written to.
7. The MSSP module shifts in the  $\overline{ACK}$  bit from the slave device and writes its value into the ACKSTAT bit of the SSPCON2 register.
8. The MSSP module generates an interrupt at the end of the 9<sup>th</sup> clock cycle by setting the SSPIF bit.
9. The user loads the SSPBUF with eight bits of data.
10. Data is shifted out the SDA pin until all eight bits are transmitted.
11. The MSSP module shifts in the  $\overline{ACK}$  bit from the slave device and writes its value into the ACKSTAT bit of the SSPCON2 register.
12. Steps 8–11 are repeated for all transmitted data bytes.
13. The user generates a Stop or Restart condition by setting the PEN or RSEN bits of the SSPCON2 register. Interrupt is generated once the Stop/Restart condition is complete.

**FIGURE 27-20: I<sup>2</sup>C MASTER MODE WAVEFORM (TRANSMISSION, 7 OR 10-BIT ADDRESS)**

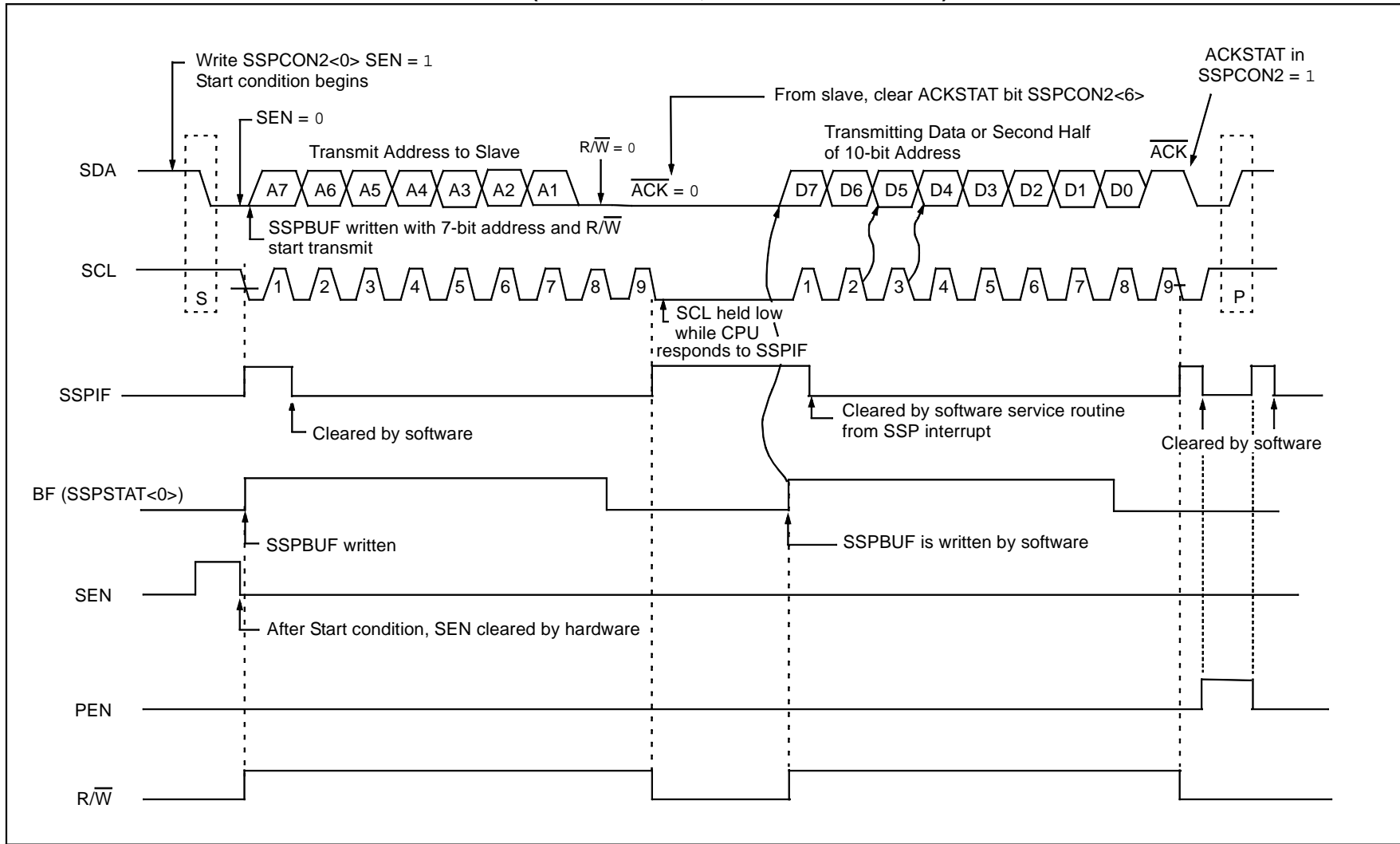

# MCP19110/11

---

## 27.5.7 I<sup>2</sup>C MASTER MODE RECEPTION

Master mode reception is enabled by programming the Receive Enable bit, RCEN bit, of the SSPCON2 register.

**Note:** The MSSP module must be in an Idle state before the RCEN bit is set, or the RCEN bit will be disregarded.

The Baud Rate Generator begins counting and on each rollover, the state of the SCL pin changes (high-to-low/low-to-high) and data is shifted into the SSPSR. After the falling edge of the eighth clock, the receive enable flag is automatically cleared, the contents of the SSPSR are loaded into the SSPBUF, the BF flag bit is set, the SSPIF flag bit is set and the Baud Rate Generator is suspended from counting, holding SCL low. The MSSP is now in Idle state awaiting the next command. When the buffer is read by the CPU, the BF flag bit is automatically cleared. The user can then send an Acknowledge bit at the end of reception by setting the Acknowledge Sequence Enable, ACKEN bit, of the SSPCON2 register.

### 27.5.7.1 BF Status Flag

In receive operation, the BF bit is set when an address or data byte is loaded into SSPBUF from SSPSR. It is cleared when the SSPBUF register is read.

### 27.5.7.2 SSPOV Status Flag

In receive operation, the SSPOV bit is set when eight bits are received into the SSPSR and the BF flag bit is already set from a previous reception.

### 27.5.7.3 WCOL Status Flag

If the user writes the SSPBUF when a receive is already in progress (i.e., SSPSR is still shifting in a data byte), the WCOL bit is set and the contents of the buffer are unchanged (the write does not occur).

### 27.5.7.4 Typical Receive Sequence:

1. The user generates a Start condition by setting the SEN bit of the SSPCON2 register.
2. SSPIF is set by hardware on completion of the Start.
3. SSPIF is cleared by software.
4. The user writes SSPBUF with the slave address to transmit and the R/W bit set.
5. Address is shifted out the SDA pin until all eight bits are transmitted. Transmission begins as soon as SSPBUF is written to.
6. The MSSP module shifts in the  $\overline{ACK}$  bit from the slave device and writes its value into the ACKSTAT bit of the SSPCON2 register.
7. The MSSP module generates an interrupt at the end of the 9<sup>th</sup> clock cycle by setting the SSPIF bit.
8. User sets the RCEN bit of the SSPCON2 register and the Master clocks in a byte from the slave.
9. After the 8<sup>th</sup> falling edge of SCL, SSPIF and BF are set.
10. Master clears SSPIF and reads the received byte from SSPBUF, clears BF.
11. Master sets  $\overline{ACK}$  value sent to slave in ACKDT bit of the SSPCON2 register and initiates the  $\overline{ACK}$  by setting the ACKEN bit.
12. Masters  $\overline{ACK}$  is clocked out to the Slave and SSPIF is set.
13. The user clears SSPIF.
14. Steps 8–13 are repeated for each received byte from the slave.
15. Master sends a not  $\overline{ACK}$  or Stop to end communication.

**FIGURE 27-21: I<sup>2</sup>C MASTER MODE WAVEFORM (RECEPTION, 7-BIT ADDRESS)**

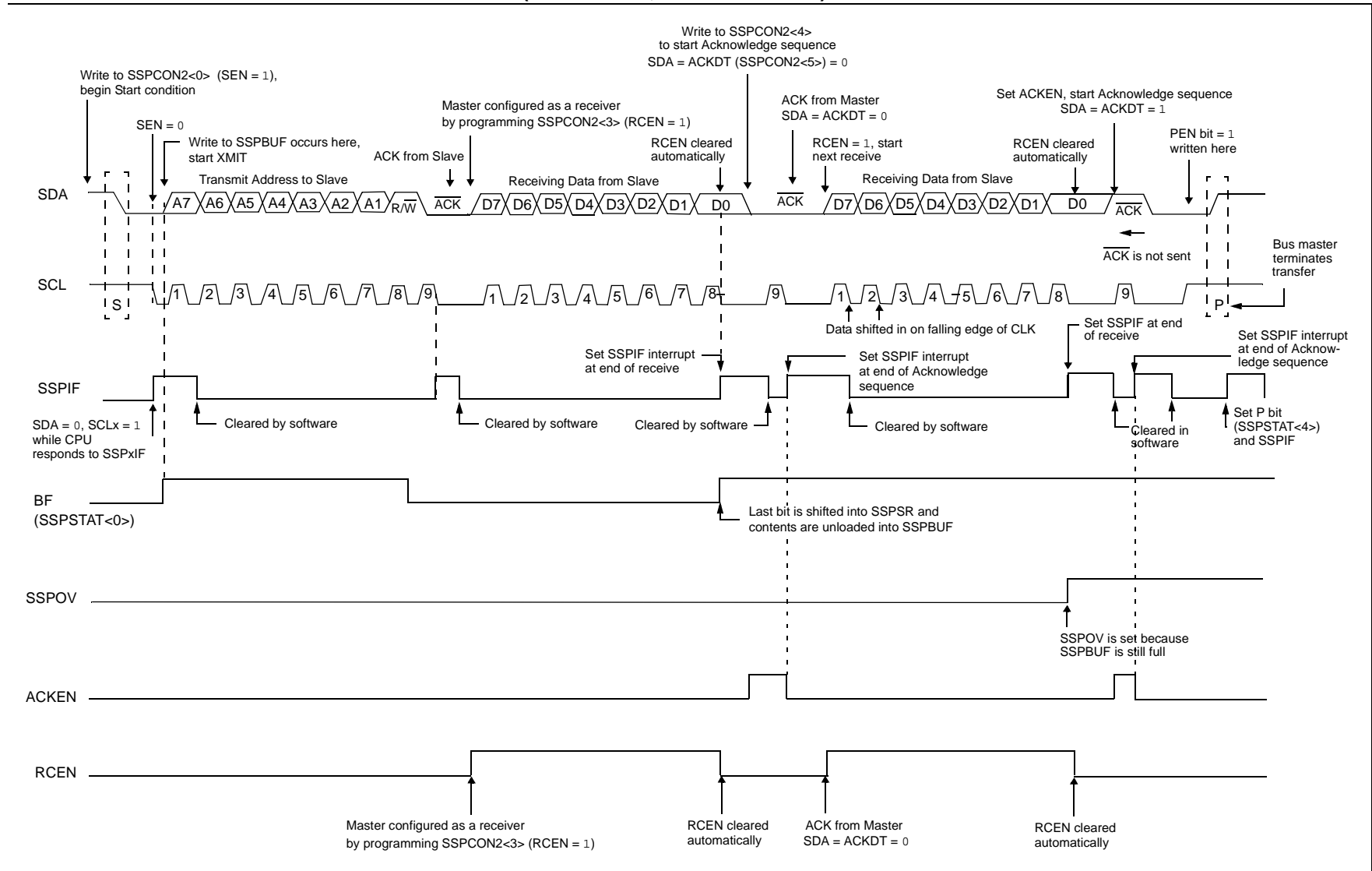

# MCP19110/11

## 27.5.8 ACKNOWLEDGE SEQUENCE TIMING

An Acknowledge sequence is enabled by setting the Acknowledge Sequence Enable bit, ACKEN bit, of the SSPCON2 register. When this bit is set, the SCL pin is pulled low and the contents of the Acknowledge data bit are presented on the SDA pin. If the user wishes to generate an Acknowledge, then the ACKDT bit should be cleared. If not, the user should set the ACKDT bit before starting an Acknowledge sequence. The Baud Rate Generator then counts for one rollover period ( $T_{BRG}$ ) and the SCL pin is deasserted (pulled high). When the SCL pin is sampled high (clock arbitration), the Baud Rate Generator counts for  $T_{BRG}$ . The SCL pin is then pulled low. Following this, the ACKEN bit is automatically cleared, the Baud Rate Generator is turned off and the MSSP module then goes into Idle mode (Figure 27-22).

### 27.5.8.1 WCOL Status Flag

If the user writes the SSPBUF when an Acknowledge sequence is in progress, then WCOL is set and the contents of the buffer are unchanged (the write does not occur).

## 27.5.9 STOP CONDITION TIMING

A Stop bit is asserted on the SDA pin at the end of a receive/transmit by setting the Stop Sequence Enable bit, PEN bit of the SSPCON2 register. At the end of a receive/transmit, the SCL line is held low after the falling edge of the 9<sup>th</sup> clock. When the PEN bit is set, the master will assert the SDA line low. When the SDA line is sampled low, the Baud Rate Generator is reloaded and counts down to '0'. When the Baud Rate Generator times out, the SCL pin will be brought high and one  $T_{BRG}$  (Baud Rate Generator rollover count) later, the SDA pin will be deasserted. When the SDA pin is sampled high while SCL is high, the P bit of the SSPSTAT register is set. A  $T_{BRG}$  later, the PEN bit is cleared and the SSPIF bit is set (Figure 27-23).

### 27.5.9.1 WCOL Status Flag

If the user writes the SSPBUF when a Stop sequence is in progress, then the WCOL bit is set and the contents of the buffer are unchanged (the write does not occur).

**FIGURE 27-22: ACKNOWLEDGE SEQUENCE WAVEFORM**

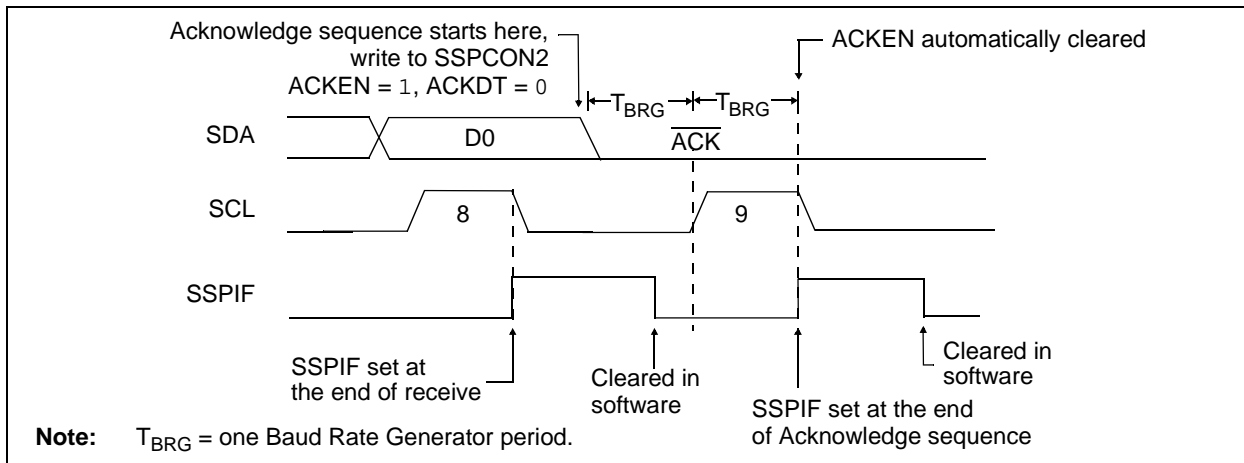

**FIGURE 27-23: STOP CONDITION RECEIVE OR TRANSMIT MODE**

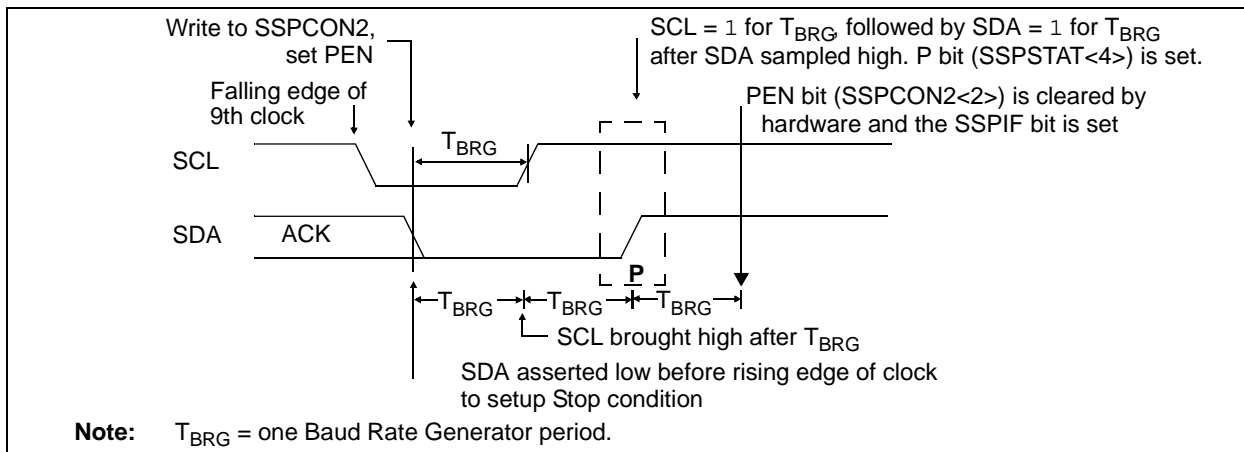



## 27.5.10 SLEEP OPERATION

While in Sleep mode, the I<sup>2</sup>C slave module can receive addresses or data, and when an address match or complete byte transfer occurs, wakes the processor from Sleep (if the MSSP interrupt is enabled).

## 27.5.11 EFFECTS OF A RESET

A Reset disables the MSSP module and terminates the current transfer.

## 27.5.12 MULTI-MASTER MODE

In Multi-Master mode, the interrupt generation on the detection of the Start and Stop conditions allows the determination of when the bus is free. The Stop (P) and Start (S) bits are cleared from a Reset or when the MSSPx module is disabled. Control of the I<sup>2</sup>C bus may be taken when the P bit of the SSPSTAT register is set, or the bus is Idle, with both the S and P bits clear. When the bus is busy, enabling the SSP interrupt will generate the interrupt when the Stop condition occurs.

In multi-master operation, the SDA line must be monitored for arbitration to see if the signal level is the expected output level. This check is performed by hardware with the result placed in the BCLIF bit.

The states where arbitration can be lost are:

- Address Transfer
- Data Transfer
- A Start Condition
- A Repeated Start Condition
- An Acknowledge Condition

## 27.5.13 MULTI-MASTER COMMUNICATION, BUS COLLISION AND BUS ARBITRATION

Multi-Master mode support is achieved by bus arbitration. When the master outputs address/data bits onto the SDA pin, arbitration takes place when the master outputs a '1' on SDA, by letting SDA float high and another master asserts a '0'. When the SCL pin floats high, data should be stable. If the expected data on SDA is a '1' and the data sampled on the SDA pin is '0', then a bus collision has taken place. The master will set the Bus Collision Interrupt Flag, BCLIF and reset the I<sup>2</sup>C port to its Idle state (Figure 27-24).

If a transmit was in progress when the bus collision occurred, the transmission is halted, the BF flag is cleared, the SDA and SCL lines are deasserted and the SSPBUF can be written to. When the user services the bus collision Interrupt Service Routine and if the I<sup>2</sup>C bus is free, the user can resume communication by asserting a Start condition.

If a Start, Repeated Start, Stop or Acknowledge condition was in progress when the bus collision occurred, the condition is aborted, the SDA and SCL lines are deasserted and the respective control bits in the SSPCON2 register are cleared. When the user services the bus collision Interrupt Service Routine and if the I<sup>2</sup>C bus is free, the user can resume communication by asserting a Start condition.

The master will continue to monitor the SDA and SCL pins. If a Stop condition occurs, the SSPIF bit will be set.

A write to the SSPBUF will start the transmission of data at the first data bit, regardless of where the transmitter left off when the bus collision occurred.

In Multi-Master mode, the interrupt generation on the detection of Start and Stop conditions allows the determination of when the bus is free. Control of the I<sup>2</sup>C bus can be taken when the P bit is set in the SSPSTAT register, or the bus is Idle and the S and P bits are cleared.

**FIGURE 27-24: BUS COLLISION TIMING FOR TRANSMIT AND ACKNOWLEDGE**

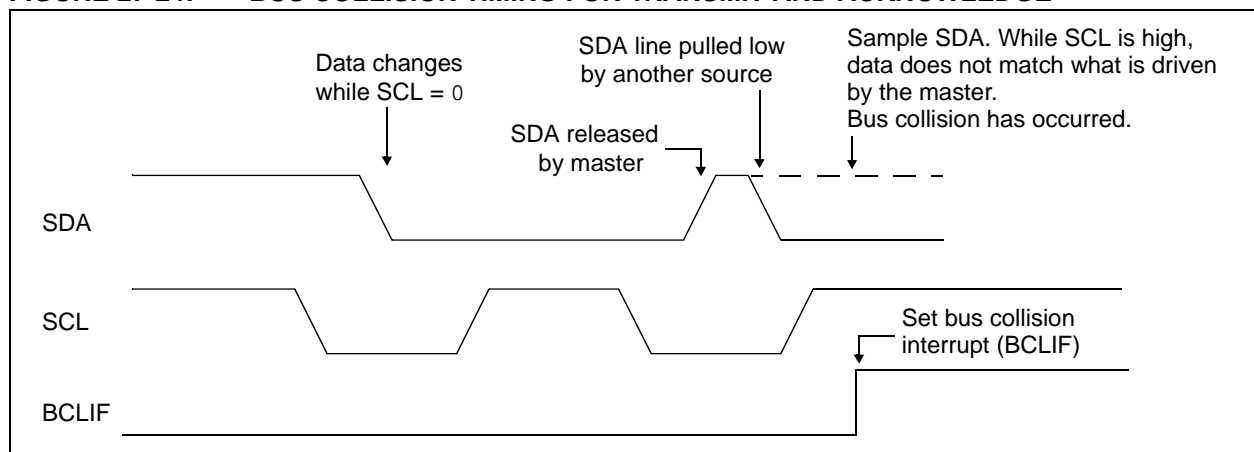

# MCP19110/11

## 27.5.13.1 Bus Collision During a Start Condition

During a Start condition, a bus collision occurs if:

- a) SDA or SCL are sampled low at the beginning of the Start condition (Figure 27-25).
- b) SCL is sampled low before SDA is asserted low (Figure 27-26).

During a Start condition, both the SDA and the SCL pins are monitored.

If the SDA pin is already low, or the SCL pin is already low, then all of the following occur:

- the Start condition is aborted
- the BCLIF flag is set
- the MSSP module is reset to its Idle state (Figure 27-25).

The Start condition begins with the SDA and SCL pins deasserted. When the SDA pin is sampled high, the Baud Rate Generator is loaded and counts down. If the SCL pin is sampled low while SDA is high, a bus collision occurs because it is assumed that another master is attempting to drive a data '1' during the Start condition.

If the SDA pin is sampled low during this count, the BRG is reset and the SDA line is asserted early (Figure 27-27). If, however, a '1' is sampled on the SDA pin, the SDA pin is asserted low at the end of the BRG count. The Baud Rate Generator is then reloaded and counts down to zero; if the SCL pin is sampled as '0' during this time, a bus collision does not occur. At the end of the BRG count, the SCL pin is asserted low.

**Note:** The reason that bus collision is not a factor during a Start condition is that no two bus masters can assert a Start condition at the exact same time. Therefore, one master will always assert SDA before the other. This condition does not cause a bus collision because the two masters must be allowed to arbitrate the first address following the Start condition. If the address is the same, arbitration must be allowed to continue into the data portion, Repeated Start or Stop conditions.

**FIGURE 27-25: BUS COLLISION DURING START CONDITION (SDA ONLY)**

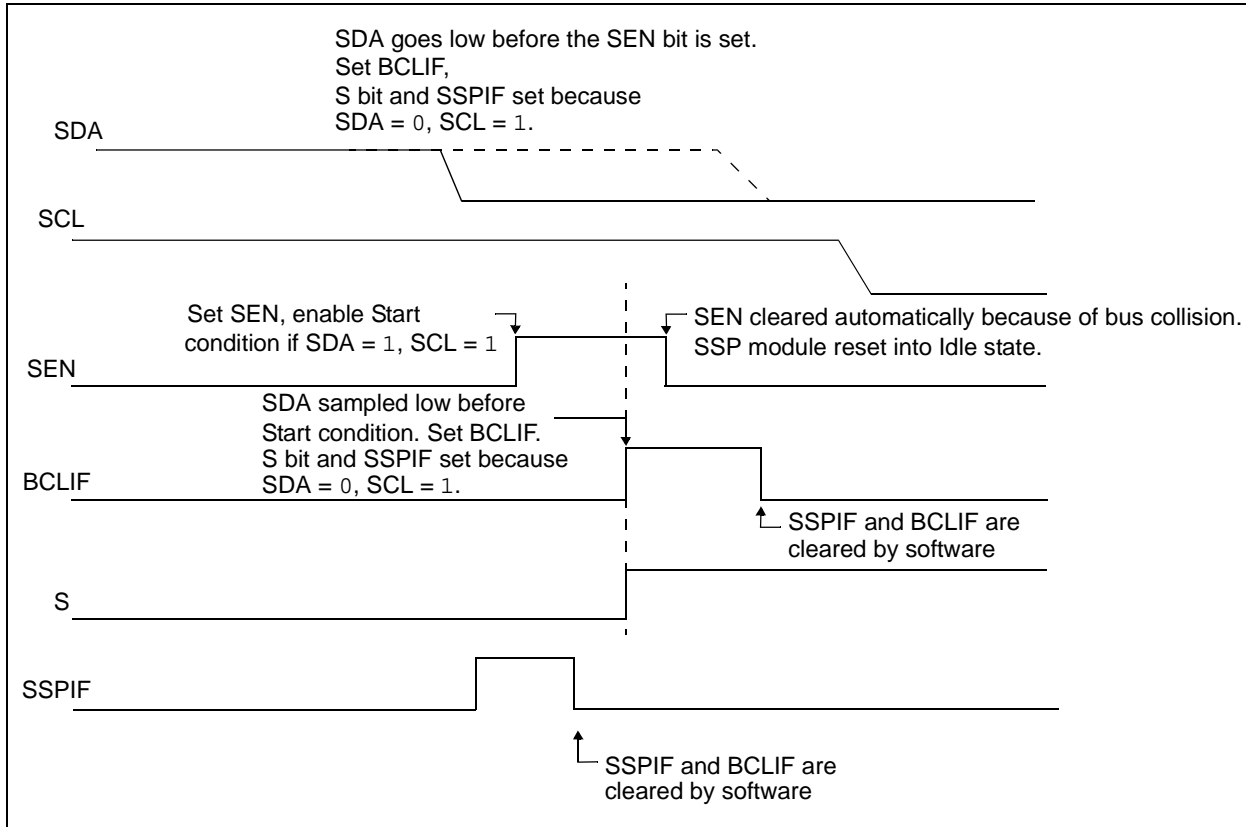

**FIGURE 27-26: BUS COLLISION DURING START CONDITION (SCL = 0)**

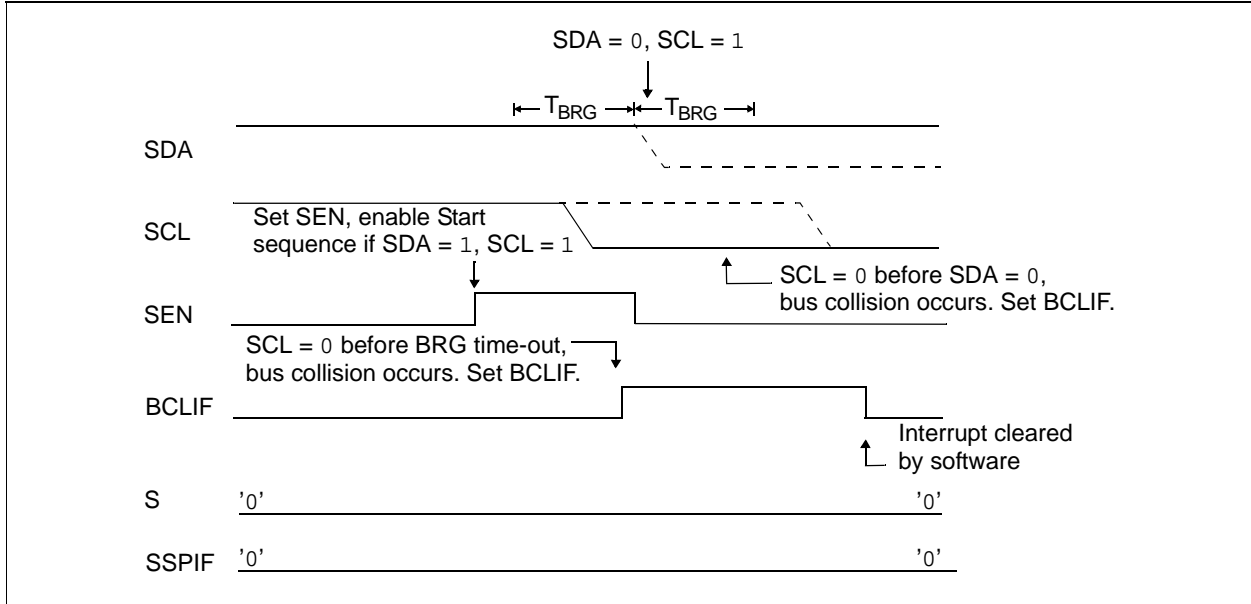

**FIGURE 27-27: BRG RESET DUE TO SDA ARBITRATION DURING START CONDITION**

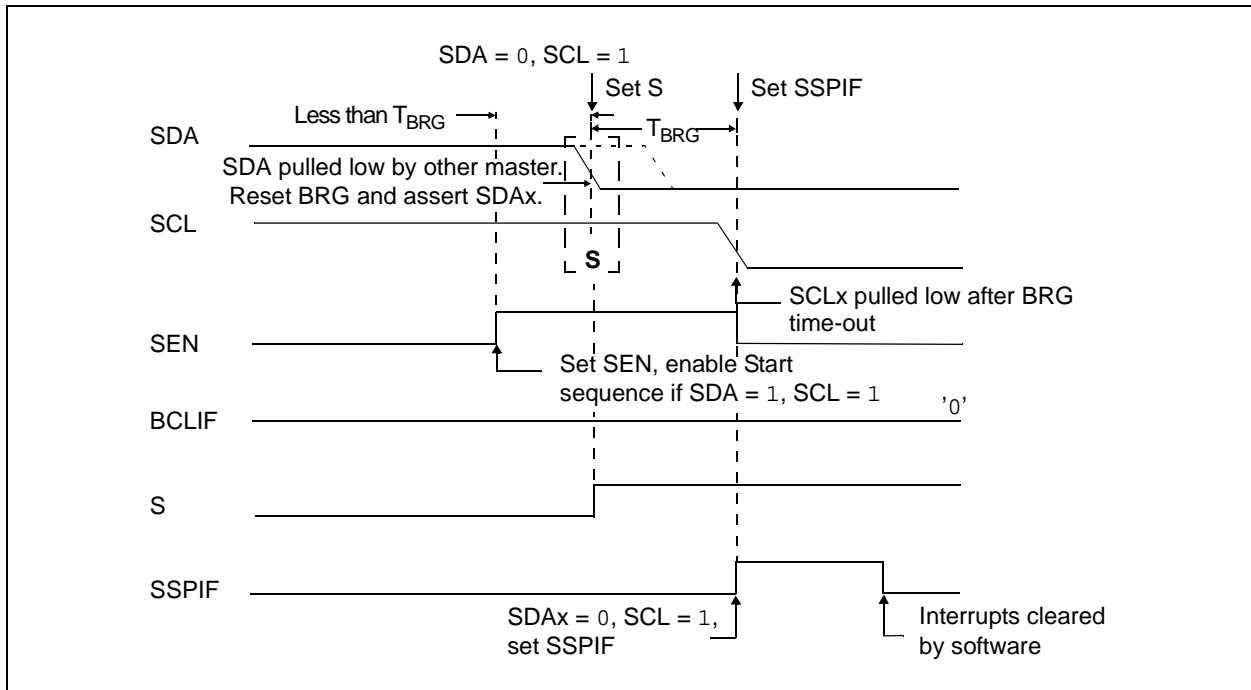

# MCP19110/11

## 27.5.13.2 Bus Collision During a Repeated Start Condition

During a Repeated Start condition, a bus collision occurs if:

- A low level is sampled on SDA when SCL goes from low level to high level.
- SCL goes low before SDA is asserted low, indicating that another master is attempting to transmit a data '1'.

When the user releases SDA and the pin is allowed to float high, the BRG is loaded with SSPADD and counts down to zero. The SCL pin is then deasserted and when sampled high, the SDA pin is sampled.

If SDA is low, a bus collision has occurred (i.e., another master is attempting to transmit a data '0', [Figure 27-28](#)). If SDA is sampled high, the BRG is reloaded and begins counting. If SDA goes from high-to-low before the BRG times out, no bus collision occurs because no two masters can assert SDA at exactly the same time.

If SCL goes from high-to-low before the BRG times out and SDA has not already been asserted, a bus collision occurs. In this case, another master is attempting to transmit a data '1' during the Repeated Start condition (see [Figure 27-29](#).)

If, at the end of the BRG time-out, both SCL and SDA are still high, the SDA pin is driven low and the BRG is reloaded and begins counting. At the end of the count, regardless of the status of the SCL pin, the SCL pin is driven low and the Repeated Start condition is complete.

**FIGURE 27-28: BUS COLLISION DURING A REPEATED START CONDITION (CASE 1)**

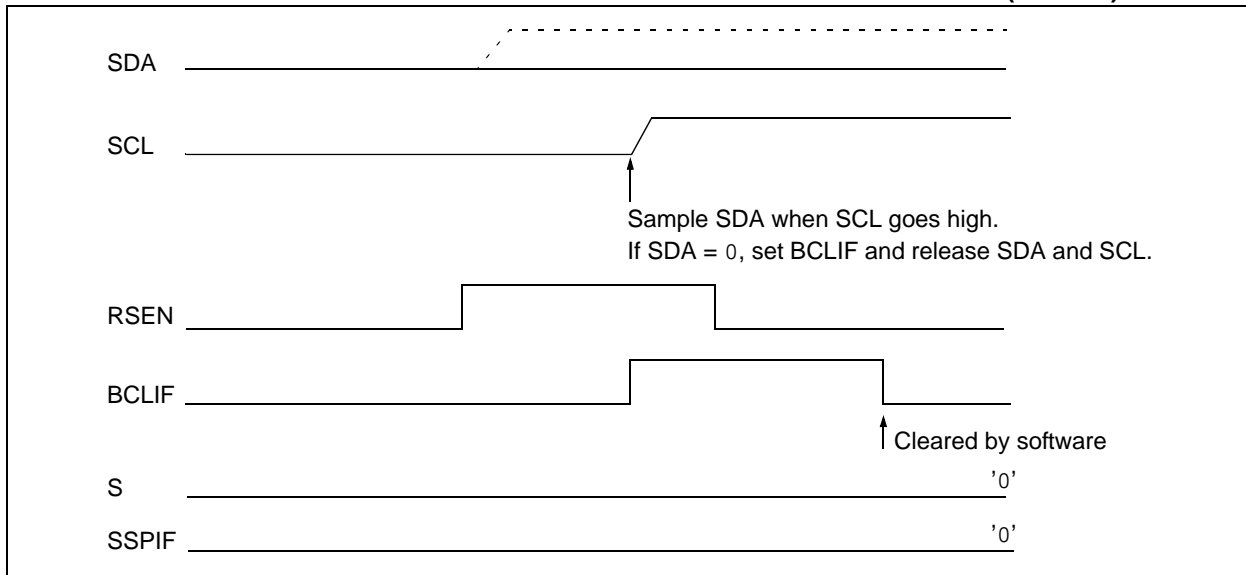

**FIGURE 27-29: BUS COLLISION DURING REPEATED START CONDITION (CASE 2)**

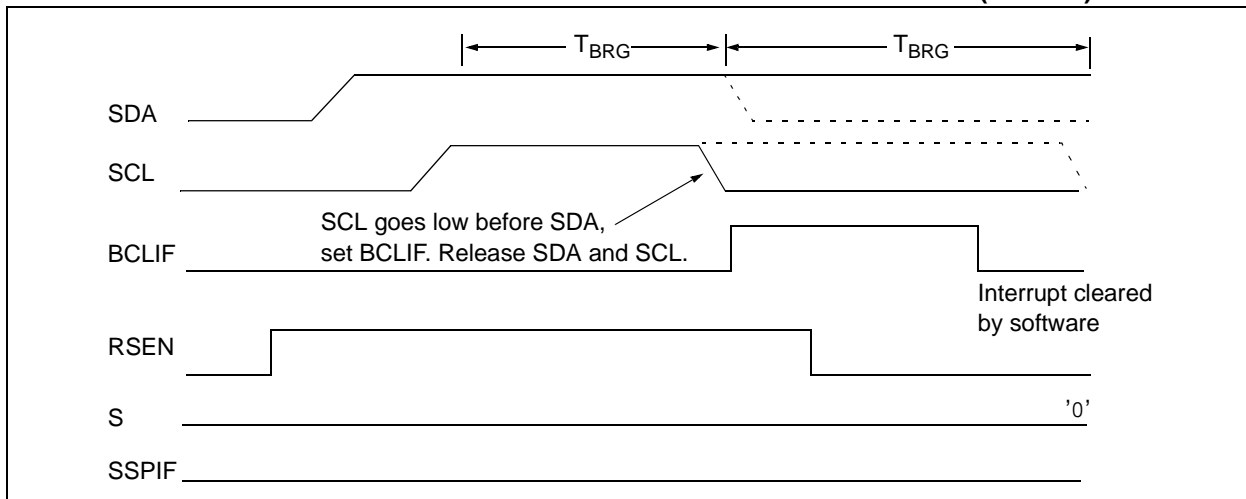

### 27.5.13.3 Bus Collision During a Stop Condition

Bus collision occurs during a Stop condition if:

- After the SDA pin has been deasserted and allowed to float high, SDA is sampled low after the BRG has timed out.
- After the SCL pin is deasserted, SCL is sampled low before SDA goes high.

The Stop condition begins with SDA asserted low. When SDA is sampled low, the SCL pin is allowed to float. When the pin is sampled high (clock arbitration), the Baud Rate Generator is loaded with SSPADD and counts down to 0. After the BRG times out, SDA is sampled. If SDA is sampled low, a bus collision has occurred. This is due to another master attempting to drive a data '0' (Figure 27-30). If the SCL pin is sampled low before SDA is allowed to float high, a bus collision occurs. This is another case of another master attempting to drive a data '0' (Figure 27-31).

**FIGURE 27-30: BUS COLLISION DURING A STOP CONDITION (CASE 1)**

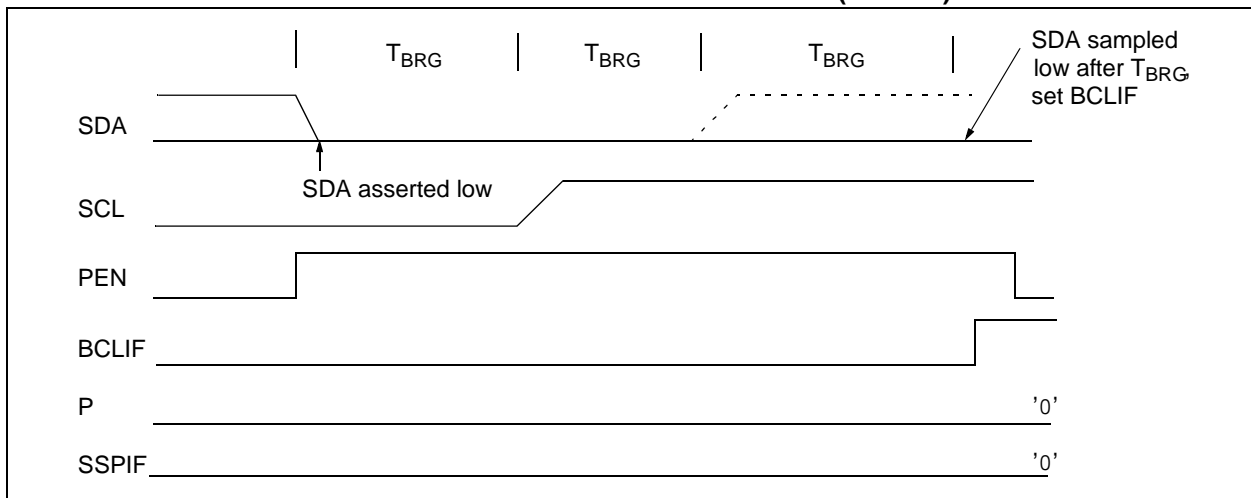

**FIGURE 27-31: BUS COLLISION DURING A STOP CONDITION (CASE 2)**

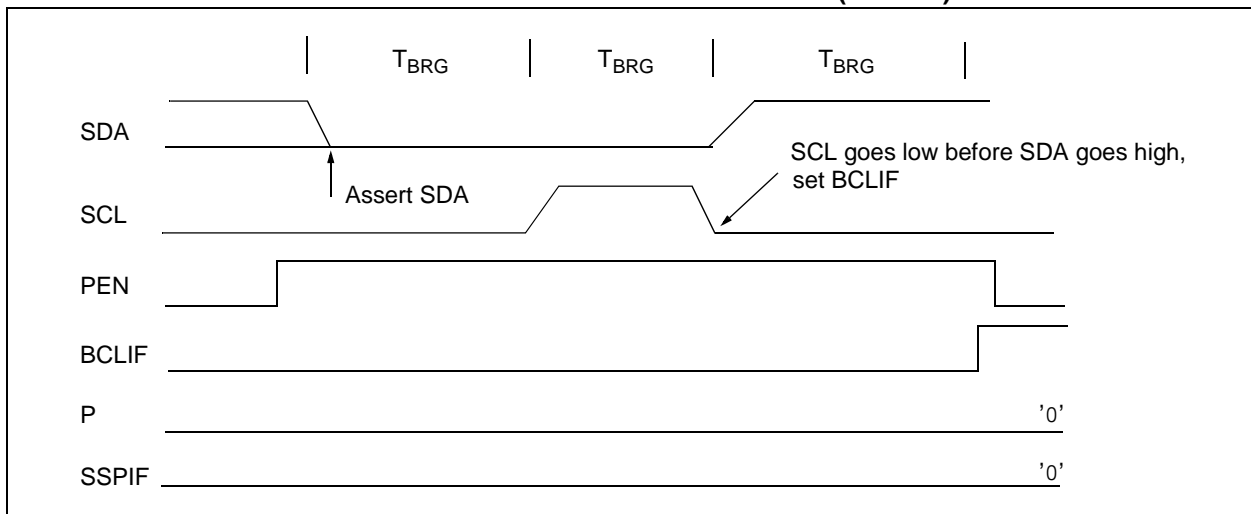

# MCP19110/11

**TABLE 27-1: SUMMARY OF REGISTERS ASSOCIATED WITH I<sup>2</sup>C OPERATION**

Name	Bit 7	Bit 6	Bit 5	Bit 4	Bit 3	Bit 2	Bit 1	Bit 0	Reset Values on Page:
INTCON	GIE	PEIE	T0IE	INTE	IOCE	T0IF	INTF	IOCF	95
PIE1	—	ADIE	BCLIE	SSPIE	—	—	TMR2IE	TMR1IE	96
PIR1	—	ADIF	BCLIF	SSPIF	—	—	TMR2IF	TMR1IF	98
TRISGPA	TRISA7	TRISA6	TRISA5	TRISA4	TRISA3	TRISA2	TRISA1	TRISA0	114
TRISGPB	TRISB7	TRISB6	TRISB5	TRISB4	TRISB3	TRISB2	TRISB1	TRISB0	117
SSPADD	ADD7	ADD6	ADD5	ADD4	ADD3	ADD2	ADD1	ADD0	188
SSPBUF	Synchronous Serial Port Receive Buffer/Transmit Register								148*
SSPCON1	WCOL	SSPOV	SSPEN	CKP	SSPM3	SSPM2	SSPM1	SSPM0	185
SSPCON2	GCEN	ACKSTAT	ACKDT	ACKEN	RCEN	PEN	RSEN	SEN	186
SSPCON3	ACKTIM	PCIE	SCIE	BOEN	SDAHT	SBCDE	AHEN	DHEN	187
SSPMSK	MSK7	MSK6	MSK5	MSK4	MSK3	MSK2	MSK1	MSK0	188
SSPSTAT	SMP	CKE	D/Ā	P	S	R/W	UA	BF	184
SSPMSK2	MSK27	MSK26	MSK25	MSK24	MSK23	MSK22	MSK21	MSK20	189
SSPADD2	ADD27	ADD26	ADD25	ADD24	ADD23	ADD22	ADD21	ADD20	189

**Legend:** — = unimplemented, read as '0'. Shaded cells are not used by the MSSP module in I<sup>2</sup>C mode.

\* Page provides register information.

## 27.6 BAUD RATE GENERATOR

The MSSP module has a Baud Rate Generator available for clock generation in I<sup>2</sup>C Master mode. The Baud Rate Generator (BRG) reload value is placed in the SSPADD register (Register 27-7). When a write occurs to SSPBUF, the Baud Rate Generator will automatically begin counting down.

Once the given operation is complete, the internal clock will automatically stop counting and the clock pin will remain in its last state.

An internal signal “Reload” in Figure 27-32 triggers the value from SSPADD to be loaded into the BRG counter. This occurs twice for each oscillation of the module clock line. The logic dictating when the reload signal is asserted depends on the mode the MSSP is being operated in.

Table 27-2 demonstrates clock rates based on instruction cycles and the BRG value loaded into SSPADD.

**EQUATION 27-1:**

$$F_{CLOCK} = \frac{F_{OSC}}{(SSPADD + 1)(4)}$$

**FIGURE 27-32: BAUD RATE GENERATOR BLOCK DIAGRAM**

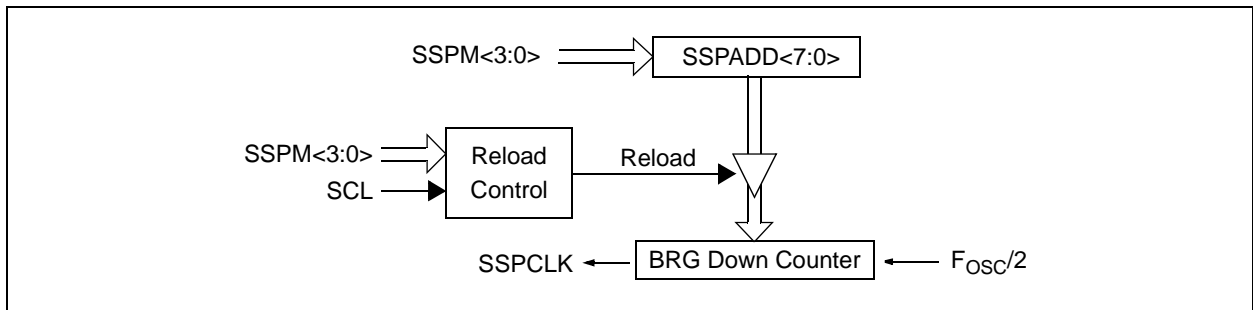

**Note:** Values of 0x00, 0x01 and 0x02 are not valid for SSPADD when used as a Baud Rate Generator for I<sup>2</sup>C. This is an implementation limitation.

**TABLE 27-2: MSSP CLOCK RATE W/BRG**

F <sub>osc</sub>	F <sub>cy</sub>	BRG Value	F <sub>CLOCK</sub> (2 Rollovers of BRG)
8 MHz	2 MHz	04h	400 kHz <sup>(1)</sup>
8 MHz	2 MHz	0Bh	166 kHz
8 MHz	2 MHz	13h	100 kHz

**Note 1:** The I<sup>2</sup>C interface does not conform to the 400 kHz I<sup>2</sup>C specification (which applies to rates greater than 100 kHz) in all details, but may be used with care where higher rates are required by the application.

# MCP19110/11

## REGISTER 27-2: SSPSTAT: SSP STATUS REGISTER

R/W-0	R/W-0	R-0	R-0	R-0	R-0	R-0	R-0
SMP	CKE	D/ $\bar{A}$	P	S	R/ $\bar{W}$	UA	BF
bit 7							bit 0

### Legend:

R = Readable bit	W = Writable bit	U = Unimplemented bit, read as '0'
-n = Value at POR	'1' = Bit is set	'0' = Bit is cleared
		x = Bit is unknown

- bit 7      **SMP:** Data Input Sample bit  
 1 = Slew rate control disabled for standard speed mode (100 kHz and 1 MHz)  
 0 = Slew rate control enabled for high speed mode (400 kHz)
- bit 6      **CKE:** Clock Edge Select bit  
 1 = Enable input logic so that thresholds are compliant with SMBus specification  
 0 = Disable SMBus specific inputs
- bit 5      **D/ $\bar{A}$ :** Data/Address bit  
 1 = Indicates that the last byte received or transmitted was data  
 0 = Indicates that the last byte received or transmitted was address
- bit 4      **P:** Stop bit  
 (This bit is cleared when the MSSP module is disabled, SSPEN is cleared.)  
 1 = Indicates that a Stop bit has been detected last (this bit is '0' on Reset)  
 0 = Stop bit was not detected last
- bit 3      **S:** Start bit  
 (This bit is cleared when the MSSP module is disabled, SSPEN is cleared.)  
 1 = Indicates that a Start bit has been detected last (this bit is '0' on Reset)  
 0 = Start bit was not detected last
- bit 2      **R/ $\bar{W}$ :** Read/Write bit information  
 This bit holds the R/ $\bar{W}$  bit information following the last address match. This bit is only valid from the address match to the next Start bit, Stop bit, or not ACK bit.  
In I<sup>2</sup>C Slave mode:  
 1 = Read  
 0 = Write  
In I<sup>2</sup>C Master mode:  
 1 = Transmit is in progress  
 0 = Transmit is not in progress  
 OR-ing this bit with SEN, RSEN, PEN, RCEN or ACKEN will indicate if the MSSP is in Idle mode.
- bit 1      **UA:** Update Address bit (10-bit I<sup>2</sup>C mode only)  
 1 = Indicates that the user needs to update the address in the SSPADD register  
 0 = Address does not need to be updated
- bit 0      **BF:** Buffer Full Status bit  
Receive:  
 1 = Receive complete, SSPBUF is full  
 0 = Receive not complete, SSPBUF is empty  
Transmit:  
 1 = Data transmit in progress (does not include the  $\bar{ACK}$  and Stop bits), SSPBUF is full  
 0 = Data transmit complete (does not include the  $\bar{ACK}$  and Stop bits), SSPBUF is empty



## REGISTER 27-3: SSPCON1: SSP CONTROL REGISTER 1

R/C/HS-0	R/C/HS-0	R/W-0	R/W-0	R/W-0	R/W-0	R/W-0	R/W-0
WCOL	SSPOV	SSPEN	CKP	SSPM<3:0>			
bit 7							bit 0

### Legend:

R = Readable bit	W = Writable bit	U = Unimplemented bit, read as '0'	
-n = Value at POR	'1' = Bit is set	'0' = Bit is cleared	x = Bit is unknown
HS = Bit is set by hardware	C = User cleared		

bit 7 **WCOL:** Write Collision Detect bit

Master mode:

1 = A write to the SSPBUF register was attempted while the I<sup>2</sup>C conditions were not valid for a transmission to be started

0 = No collision

Slave mode:

1 = The SSPBUF register is written while it is still transmitting the previous word (must be cleared in software)

0 = No collision

bit 6 **SSPOV:** Receive Overflow Indicator bit <sup>(1)</sup>

1 = A byte is received while the SSPBUF register is still holding the previous byte. SSPOV is a “don’t care” in Transmit mode (must be cleared in software).

0 = No overflow

bit 5 **SSPEN:** Synchronous Serial Port Enable bit

In both modes, when enabled, these pins must be properly configured as input or output

1 = Enables the serial port and configures the SDA and SCL pins as the source of the serial port pins <sup>(2)</sup>

0 = Disables serial port and configures these pins as I/O port pins

bit 4 **CKP:** Clock Polarity Select bit

In I<sup>2</sup>C Slave mode:

SCL release control

1 = Enable clock

0 = Holds clock low (clock stretch). (Used to ensure data setup time.)

In I<sup>2</sup>C Master mode:

Unused in this mode

bit 3-0 **SSPM<3:0>:** Synchronous Serial Port Mode Select bits

0000 = Reserved

0001 = Reserved

0010 = Reserved

0011 = Reserved

0100 = Reserved

0101 = Reserved

0110 = I<sup>2</sup>C Slave mode, 7-bit address

0111 = I<sup>2</sup>C Slave mode, 10-bit address

1000 = I<sup>2</sup>C Master mode, clock = F<sub>OSC</sub>/(4 x (SSPADD+1)) <sup>(3)</sup>

1001 = Reserved

1010 = Reserved

1011 = I<sup>2</sup>C firmware controlled Master mode (Slave idle)

1100 = Reserved

1101 = Reserved

1110 = I<sup>2</sup>C Slave mode, 7-bit address with Start and Stop bit interrupts enabled

1111 = I<sup>2</sup>C Slave mode, 10-bit address with Start and Stop bit interrupts enabled

**Note 1:** In Master mode, the overflow bit is not set since each new reception (and transmission) is initiated by writing to the SSPBUF register.

**2:** When enabled, the SDA and SCL pins must be configured as inputs.

**3:** SSPADD values of 0, 1 or 2 are not supported for I<sup>2</sup>C Mode.

# MCP19110/11

## REGISTER 27-4: SSPCON2: SSP CONTROL REGISTER 2

R/W-0/0	R-0/0	R/W-0/0	R/S/HS-0/0	R/S/HS-0/0	R/S/HS-0/0	R/S/HS-0/0	R/W/HS-0/0
GCEN	ACKSTAT	ACKDT	ACKEN	RCEN	PEN	RSEN	SEN
bit 7							bit 0

### Legend:

R = Readable bit	W = Writable bit	U = Unimplemented bit, read as '0'
'1' = Bit is set	'0' = Bit is cleared	x = Bit is unknown
H = Bit is set by hardware	S = User set	-n/n = Value at POR/Value at all other resets

- bit 7      **GCEN:** General Call Enable bit (in I<sup>2</sup>C Slave mode only)  
 1 = Enable interrupt when a general call address (0x00 or 00h) is received in the SSPSR  
 0 = General call address disabled
- bit 6      **ACKSTAT:** Acknowledge Status bit  
 1 = Acknowledge was not received  
 0 = Acknowledge was received
- bit 5      **ACKDT:** Acknowledge Data bit  
In Receive mode:  
 Value transmitted when the user initiates an Acknowledge sequence at the end of a receive  
 1 = Not Acknowledge  
 0 = Acknowledge
- bit 4      **ACKEN:** Acknowledge Sequence Enable bit (in I<sup>2</sup>C Master mode only)  
In Master Receive mode:  
 1 = Initiate Acknowledge sequence on SDA and SCL pins, and transmit ACKDT data bit.  
 Automatically cleared by hardware.  
 0 = Acknowledge sequence Idle
- bit 3      **RCEN:** Receive Enable bit (in I<sup>2</sup>C Master mode only)  
 1 = Enables Receive mode for I<sup>2</sup>C  
 0 = Receive Idle
- bit 2      **PEN:** Stop Condition Enable bit (in I<sup>2</sup>C Master mode only)  
SCK Release Control:  
 1 = Initiate Stop condition on SDA and SCL pins. Automatically cleared by hardware.  
 0 = Stop condition Idle
- bit 1      **RSEN:** Repeated Start Condition Enabled bit (in I<sup>2</sup>C Master mode only)  
 1 = Initiate Repeated Start condition on SDA and SCL pins. Automatically cleared by hardware.  
 0 = Repeated Start condition Idle
- bit 0      **SEN:** Start Condition Enabled bit (in I<sup>2</sup>C Master mode only)  
In Master mode:  
 1 = Initiate Start condition on SDA and SCL pins. Automatically cleared by hardware.  
 0 = Start condition Idle  
In Slave mode:  
 1 = Clock stretching is enabled for both slave transmit and slave receive (stretch enabled)  
 0 = Clock stretching is disabled

**Note 1:** For bits ACKEN, RCEN, PEN, RSEN, SEN: If the I<sup>2</sup>C module is not in the Idle mode, this bit may not be set (no spooling) and the SSPBUF may not be written (or writes to the SSPBUF are disabled).

## REGISTER 27-5: SSPCON3: SSP CONTROL REGISTER 3

R-0/0	R/W-0/0	R/W-0/0	R/W-0/0	R/W-0/0	R/W-0/0	R/W-0/0	R/W-0/0
ACKTIM	PCIE	SCIE	BOEN	SDAHT	SBCDE	AHEN	DHEN
bit 7							bit 0

### Legend:

R = Readable bit                      W = Writable bit                      U = Unimplemented bit, read as '0'  
 -n/n = Value at POR/Value at '1' = Bit is set                      '0' = Bit is cleared                      x = Bit is unknown  
 all other resets

- bit 7            **ACKTIM:** Acknowledge Time Status bit<sup>(2)</sup>  
 1 = Indicates the I<sup>2</sup>C bus is in an Acknowledge sequence, set on the 8<sup>th</sup> falling edge of SCL clock  
 0 = Not an Acknowledge sequence, cleared on the 9<sup>th</sup> rising edge of SCL clock
- bit 6            **PCIE:** Stop Condition Interrupt Enable bit  
 1 = Enable interrupt on detection of Stop condition  
 0 = Stop detection interrupts are disabled<sup>(1)</sup>
- bit 5            **SCIE:** Start Condition Interrupt Enable bit  
 1 = Enable interrupt on detection of Start or Restart conditions  
 0 = Start detection interrupts are disabled<sup>(1)</sup>
- bit 4            **BOEN:** Buffer Overwrite Enable bit  
In I<sup>2</sup>C Master mode:  
                   This bit is ignored.  
In I<sup>2</sup>C Slave mode:  
                   1 = SSPBUF is updated and  $\overline{\text{ACK}}$  is generated for a received address/data byte, ignoring the state of the SSPOV bit only if the BF bit = 0.  
                   0 = SSPBUF is only updated when SSPOV is clear
- bit 3            **SDAHT:** SDA Hold Time Selection bit  
 1 = Minimum of 300 ns hold time on SDA after the falling edge of SCL  
 0 = Minimum of 100 ns hold time on SDA after the falling edge of SCL
- bit 2            **SBCDE:** Slave Mode Bus Collision Detect Enable bit (I<sup>2</sup>C Slave mode only)  
 If on the rising edge of SCL, SDA is sampled low when the module is outputting a high state, the BCLIF bit of the PIR2 register is set, and bus goes Idle  
 1 = Enable slave bus collision interrupts  
 0 = Slave bus collision interrupts are disabled
- bit 1            **AHEN:** Address Hold Enable bit (I<sup>2</sup>C Slave mode only)  
 1 = Following the 8<sup>th</sup> falling edge of SCL for a matching received address byte; CKP bit of the SSPCON1 register will be cleared and the SCL will be held low.  
 0 = Address holding is disabled
- bit 0            **DHEN:** Data Hold Enable bit (I<sup>2</sup>C Slave mode only)  
 1 = Following the 8<sup>th</sup> falling edge of SCL for a received data byte; slave hardware clears the CKP bit of the SSPCON1 register and SCL is held low.  
 0 = Data holding is disabled

- Note 1:** This bit has no effect in Slave modes that Start and Stop condition detection is explicitly listed as enabled.  
**Note 2:** The ACKTIM Status bit is only active when the AHEN bit or DHEN bit is set.

# MCP19110/11

## REGISTER 27-6: SSPMSK: SSP MASK REGISTER 1

R/W-1	R/W-1	R/W-1	R/W-1	R/W-1	R/W-1	R/W-1	R/W-1
MSK<7:0>							
bit 7							bit 0

### Legend:

R = Readable bit                      W = Writable bit                      U = Unimplemented bit, read as '0'  
-n = Value at POR                      '1' = Bit is set                      '0' = Bit is cleared                      x = Bit is unknown

- bit 7-1            **MSK<7:1>**: Mask bits  
1 = The received address bit n is compared to SSPADD<n> to detect I<sup>2</sup>C address match  
0 = The received address bit n is not used to detect I<sup>2</sup>C address match
- bit 0            **MSK<0>**: Mask bit for I<sup>2</sup>C Slave mode, 10-bit Address  
I<sup>2</sup>C Slave mode, 10-bit address (SSPM<3:0> = 0111 or 1111):  
1 = The received address bit 0 is compared to SSPADD<0> to detect I<sup>2</sup>C address match  
0 = The received address bit 0 is not used to detect I<sup>2</sup>C address match  
I<sup>2</sup>C Slave mode, 7-bit address, the bit is ignored

## REGISTER 27-7: SSPADD: MSSP ADDRESS AND BAUD RATE REGISTER 1

R/W-0	R/W-0	R/W-0	R/W-0	R/W-0	R/W-0	R/W-0	R/W-0
ADD<7:0>							
bit 7							bit 0

### Legend:

R = Readable bit                      W = Writable bit                      U = Unimplemented bit, read as '0'  
-n = Value at POR                      '1' = Bit is set                      '0' = Bit is cleared                      x = Bit is unknown

### Master mode:

- bit 7-0            **ADD<7:0>**: Baud Rate Clock Divider bits  
SCL pin clock period = ((ADD<7:0> + 1) x 4)/F<sub>OSC</sub>

### 10-Bit Slave mode — Most Significant Address byte:

- bit 7-3            **Not used:** Unused for Most Significant Address byte. Bit state of this register is a “don't care”. Bit pattern sent by master is fixed by I<sup>2</sup>C specification and must be equal to '11110'. However, those bits are compared by hardware and are not affected by the value in this register.
- bit 2-1            **ADD<2:1>**: Two Most Significant bits of 10-bit address
- bit 0            **Not used:** Unused in this mode. Bit state is a “don't care”.

### 10-Bit Slave mode — Least Significant Address byte:

- bit 7-0            **ADD<7:0>**: Eight Least Significant bits of 10-bit address

### 7-Bit Slave mode:

- bit 7-1            **ADD<7:1>**: 7-bit address
- bit 0            **Not used:** Unused in this mode. Bit state is a “don't care”.

## REGISTER 27-8: SSPMSK2: SSP MASK REGISTER 2

R/W-1	R/W-1	R/W-1	R/W-1	R/W-1	R/W-1	R/W-1	R/W-1
MSK2<7:0>							
bit 7							bit 0

### Legend:

R = Readable bit	W = Writable bit	U = Unimplemented bit, read as '0'
-n = Value at POR	'1' = Bit is set	'0' = Bit is cleared      x = Bit is unknown

- bit 7-1      **MSK2<7:1>**: Mask bits  
 1 = The received address bit n is compared to SSPADD2<n> to detect I<sup>2</sup>C address match  
 0 = The received address bit n is not used to detect I<sup>2</sup>C address match
- bit 0      **MSK2<0>**: Mask bit for I<sup>2</sup>C Slave mode, 10-bit Address  
 I<sup>2</sup>C Slave mode, 10-bit address (SSPM<3:0> = 0111 or 1111):  
 1 = The received address bit 0 is compared to SSPADD2<0> to detect I<sup>2</sup>C address match  
 0 = The received address bit 0 is not used to detect I<sup>2</sup>C address match  
 I<sup>2</sup>C Slave mode, 7-bit address, the bit is ignored

## REGISTER 27-9: SSPADD2: MSSP ADDRESS 2

R/W-0	R/W-0	R/W-0	R/W-0	R/W-0	R/W-0	R/W-0	R/W-0
ADD2<7:0>							
bit 7							bit 0

### Legend:

R = Readable bit	W = Writable bit	U = Unimplemented bit, read as '0'
-n = Value at POR	'1' = Bit is set	'0' = Bit is cleared      x = Bit is unknown

### Master mode:

- bit 7-0      **ADD2<7:0>**: Baud Rate Clock Divider bits  
 SCL pin clock period = ((ADD<7:0> + 1) \* 4)/Fosc

### 10-Bit Slave mode — Most Significant Address byte:

- bit 7-3      **Not used:** Unused for Most Significant Address byte. Bit state of this register is a “don't care”. Bit pattern sent by master is fixed by I<sup>2</sup>C specification and must be equal to '11110'. However, those bits are compared by hardware and are not affected by the value in this register.
- bit 2-1      **ADD2<2:1>**: Two Most Significant bits of 10-bit address
- bit 0      **ADD2<0>**: SSPADD2 Enable bit.  
 1 = Enable address matching with SSPADD2  
 0 = Disable address matching with SSPADD2

### 10-Bit Slave mode — Least Significant Address byte:

- bit 7-0      **ADD2<7:0>**: Eight Least Significant bits of 10-bit address

### 7-Bit Slave mode:

- bit 7-1      **ADD2<7:1>**: 7-bit address
- bit 0      **ADD2<0>**: SSPADD2 Enable bit.  
 1 = Enable address matching with SSPADD2  
 0 = Disable address matching with SSPADD2

# MCP19110/11

---

NOTES:

## 28.0 IN-CIRCUIT SERIAL PROGRAMMING™ (ICSP™)

ICSP programming allows customers to manufacture circuit boards with unprogrammed devices. Programming can be done after the assembly process, allowing the device to be programmed with the most recent firmware or a custom firmware. Five pins are needed for ICSP programming:

- ICSPCLK
- ICSPDAT
- MCLR
- V<sub>DD</sub>
- V<sub>SS</sub>

In Program/Verify mode, the Program Memory, User IDs and the Configuration Words are programmed through serial communications. The ICSPDAT pin is a bidirectional I/O used for transferring the serial data and the ICSPCLK pin is the clock input. The device is placed into a Program/Verify mode by holding the ICSPDAT and ICSPCLK pins low, while raising the MCLR pin from V<sub>IL</sub> to V<sub>IHH</sub>.

## 28.1 Common Programming Interfaces

Connection to a target device is typically done through an ICSP header. A commonly found connector on development tools is the RJ-11 in the 6P6C (6 pin, 6 connector) configuration. See [Figure 28-1](#).

**FIGURE 28-1: ICD RJ-11 STYLE CONNECTOR INTERFACE**

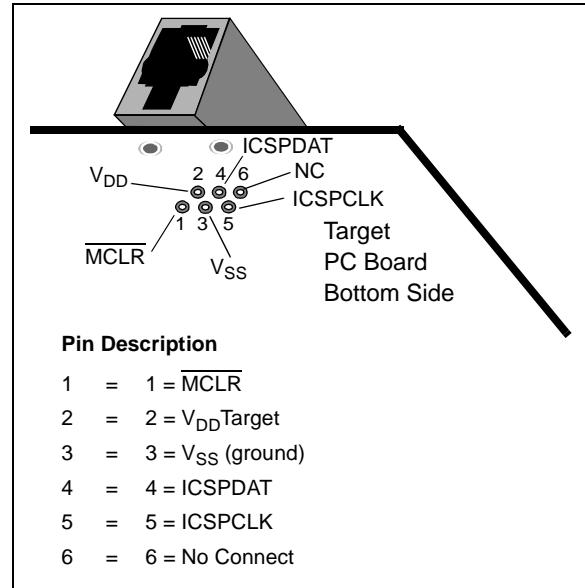

Another connector often found in use with the PICKit™ programmers is a standard 6-pin header with 0.1 inch spacing. Refer to [Figure 28-2](#).

**FIGURE 28-2: PICKit-STYLE CONNECTOR INTERFACE**

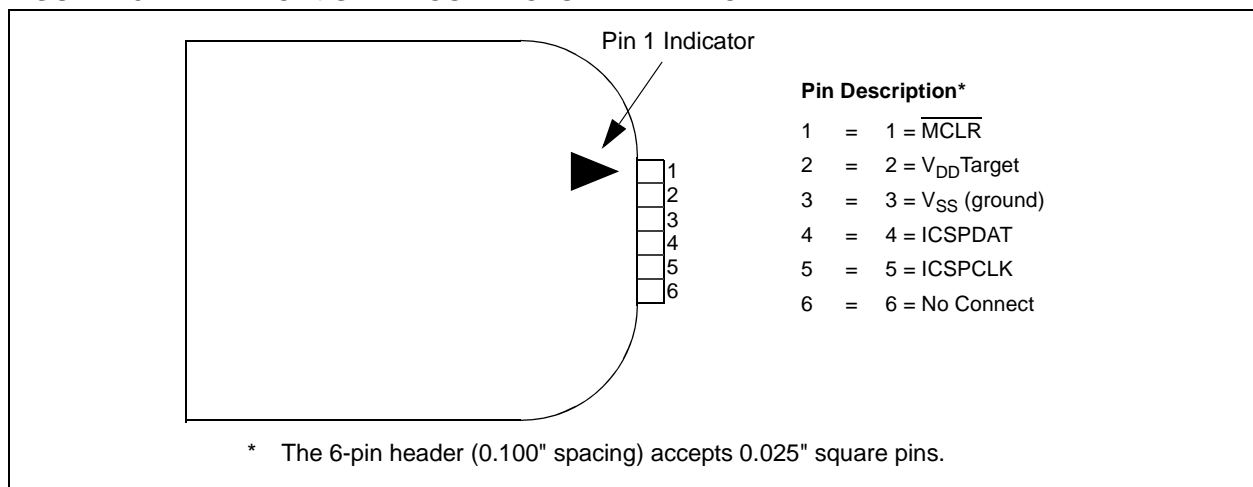

# MCP19110/11

For additional interface recommendations, refer to your specific device programmer manual prior to PCB design.

It is recommended that isolation devices be used to separate the programming pins from other circuitry. The type of isolation is highly dependent on the specific application and may include devices, such as resistors, diodes, or even jumpers. See [Figure 28-3](#) for more information.

**FIGURE 28-3: TYPICAL CONNECTION FOR ICSP PROGRAMMING**

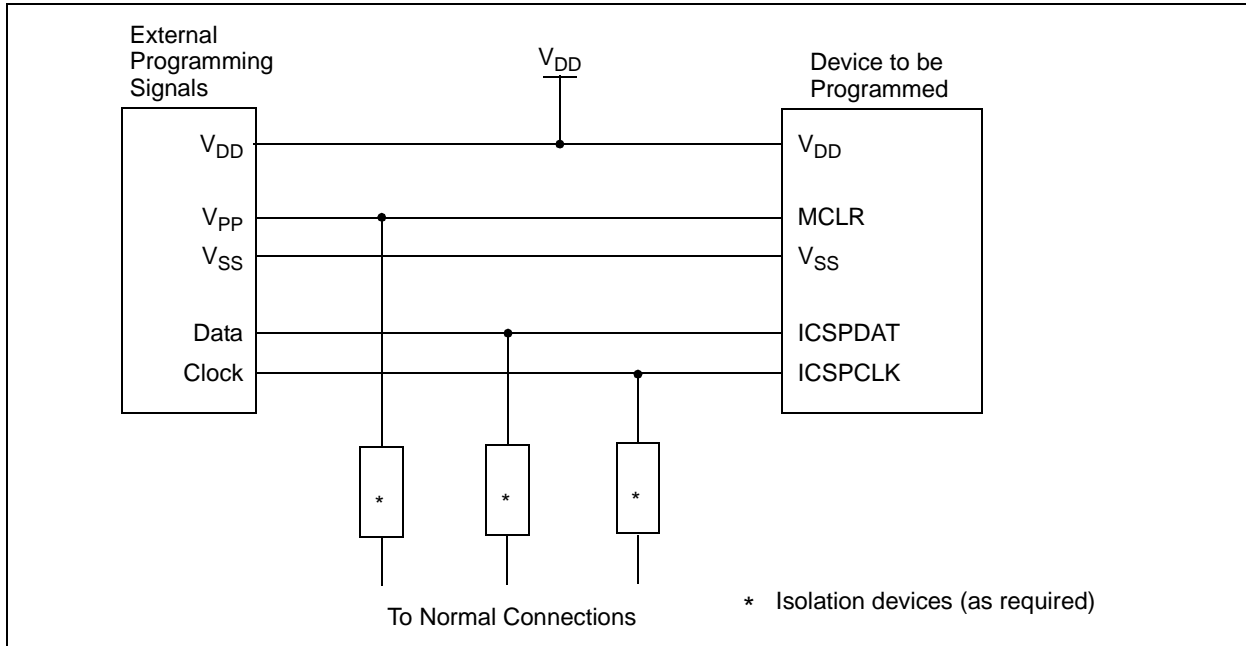

## 28.2 In-Circuit Debugger

In-circuit debugging requires access to the ICDCLK, ICDDATA, and MCLR pins. These pins are only available on the MCP19111 device.



## 29.0 INSTRUCTION SET SUMMARY

The MCP19110/11 instruction set is highly orthogonal and is comprised of three basic categories:

- **Byte-oriented** operations
- **Bit-oriented** operations
- **Literal and control** operations

Each instruction is a 14-bit word divided into an **opcode**, which specifies the instruction type, and one or more **operands**, which further specify the operation of the instruction. The formats for each of the categories are presented in [Figure 29-1](#), while the various opcode fields are summarized in [Table 29-1](#).

[Table 29-2](#) lists the instructions recognized by the MPASM™ assembler.

For **byte-oriented** instructions, 'f' represents a file register designator and 'd' represents a destination designator. The file register designator specifies which file register is to be used by the instruction.

The destination designator specifies where the result of the operation is to be placed. If 'd' is zero, the result is placed in the W register. If 'd' is one, the result is placed in the file register specified in the instruction.

For **bit-oriented** instructions, 'b' represents a bit field designator, which selects the bit affected by the operation, while 'f' represents the address of the file in which the bit is located.

For **literal and control** operations, 'k' represents an 8-bit or 11-bit constant, or literal value.

One instruction cycle consists of four oscillator periods; for an oscillator frequency of 4 MHz, this gives a normal instruction execution time of 1 μs. All instructions are executed within a single instruction cycle, unless a conditional test is true, or the program counter is changed as a result of an instruction. When this occurs, the execution takes two instruction cycles, with the second cycle executed as an NOP.

All instruction examples use the format '0xhh' to represent a hexadecimal number, where 'h' signifies a hexadecimal digit.

### 29.1 Read-Modify-Write Operations

Any instruction that specifies a file register as part of the instruction performs a Read-Modify-Write (RMW) operation. The register is read, the data is modified, and the result is stored according to either the instruction or the destination designator 'd'. A read operation is performed on a register even if the instruction writes to that register.

For example, a `CLRF PORTA` instruction will read PORTGPA, clear all the data bits, then write the result back to PORTGPA. This example would have the unintended consequence of clearing the condition that set the IOCF flag.

**TABLE 29-1: OPCODE FIELD DESCRIPTIONS**

Field	Description
f	Register file address (0x00 to 0x7F)
W	Working register (accumulator)
b	Bit address within an 8-bit file register
k	Literal field, constant data or label
x	Don't care location (= 0 or 1). The assembler will generate code with x = 0. It is the recommended form of use for compatibility with all Microchip software tools.
d	Destination select; d = 0: store result in W, d = 1: store result in file register f. Default is d = 1.
PC	Program Counter
$\overline{TO}$	Time-Out bit
C	Carry bit
DC	Digit carry bit
Z	Zero bit
$\overline{PD}$	Power-Down bit

**FIGURE 29-1: GENERAL FORMAT FOR INSTRUCTIONS**

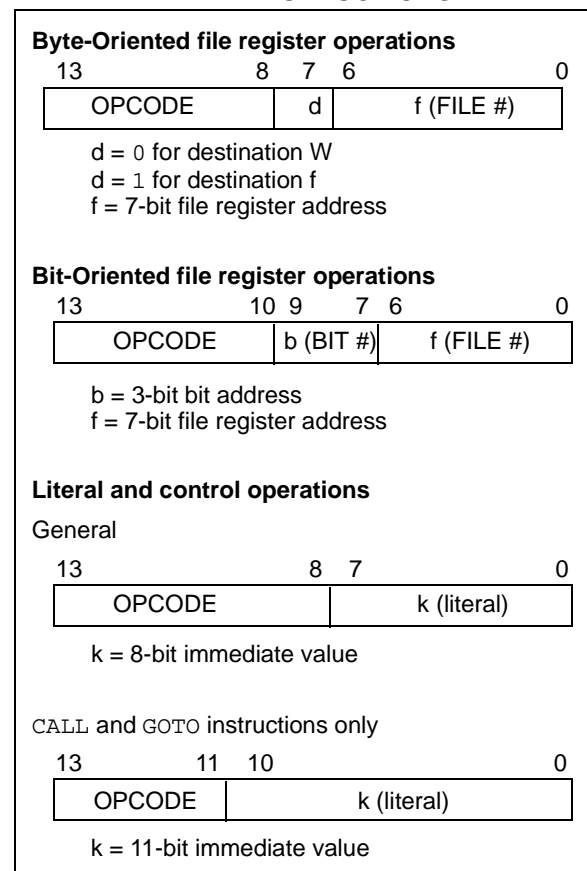

# MCP19110/11

**TABLE 29-2: MCP19110/11 INSTRUCTION SET**

Mnemonic, Operands	Description	Cycles	14-Bit Opcode		Status Affected	Notes
			MSb	LSb		
<b>BYTE-ORIENTED FILE REGISTER OPERATIONS</b>						
ADDWF	f, d	Add W and f	1	00	0111 dfff ffff	C, DC, Z 1, 2
ANDWF	f, d	AND W with f	1	00	0101 dfff ffff	Z 1, 2
CLRF	f	Clear f	1	00	0001 1fff ffff	Z 2
CLRW	–	Clear W	1	00	0001 0xxx xxxx	Z
COMF	f, d	Complement f	1	00	1001 dfff ffff	Z 1, 2
DECf	f, d	Decrement f	1	00	0011 dfff ffff	Z 1, 2
DECFSZ	f, d	Decrement f, Skip if 0	1(2)	00	1011 dfff ffff	Z 1, 2, 3
INCF	f, d	Increment f	1	00	1010 dfff ffff	Z 1, 2
INCFSZ	f, d	Increment f, Skip if 0	1(2)	00	1111 dfff ffff	Z 1, 2, 3
IORWF	f, d	Inclusive OR W with f	1	00	0100 dfff ffff	Z 1, 2
MOVF	f, d	Move f	1	00	1000 dfff ffff	Z 1, 2
MOVWF	f	Move W to f	1	00	0000 1fff ffff	
NOP	–	No Operation	1	00	0000 0xx0 0000	
RLF	f, d	Rotate Left f through Carry	1	00	1101 dfff ffff	C 1, 2
RRF	f, d	Rotate Right f through Carry	1	00	1100 dfff ffff	C 1, 2
SUBWF	f, d	Subtract W from f	1	00	0010 dfff ffff	C, DC, Z 1, 2
SWAPF	f, d	Swap nibbles in f	1	00	1110 dfff ffff	Z 1, 2
XORWF	f, d	Exclusive OR W with f	1	00	0110 dfff ffff	Z 1, 2
<b>BIT-ORIENTED FILE REGISTER OPERATIONS</b>						
BCF	f, b	Bit Clear f	1	01	00bb bfff ffff	1, 2
BSF	f, b	Bit Set f	1	01	01bb bfff ffff	1, 2
BTFSC	f, b	Bit Test f, Skip if Clear	1 (2)	01	10bb bfff ffff	3
BTFSS	f, b	Bit Test f, Skip if Set	1 (2)	01	11bb bfff ffff	3
<b>LITERAL AND CONTROL OPERATIONS</b>						
ADDLW	k	Add literal and W	1	11	111x kkkk kkkk	C, DC, Z
ANDLW	k	AND literal with W	1	11	1001 kkkk kkkk	Z
CALL	k	Call Subroutine	2	10	0kkk kkkk kkkk	
CLRWD <sub>T</sub>	–	Clear Watchdog Timer	1	00	0000 0110 0100	$\overline{TO}$ , $\overline{PD}$
GOTO	k	Go to address	2	10	1kkk kkkk kkkk	
IORLW	k	Inclusive OR literal with W	1	11	1000 kkkk kkkk	Z
MOVLW	k	Move literal to W	1	11	00xx kkkk kkkk	
RETFIE	–	Return from interrupt	2	00	0000 0000 1001	
RETLW	k	Return with literal in W	2	11	01xx kkkk kkkk	
RETURN	–	Return from Subroutine	2	00	0000 0000 1000	
SLEEP	–	Go into Standby mode	1	00	0000 0110 0011	$\overline{TO}$ , $\overline{PD}$
SUBLW	k	Subtract W from literal	1	11	110x kkkk kkkk	C, DC, Z
XORLW	k	Exclusive OR literal with W	1	11	1010 kkkk kkkk	Z

**Note 1:** When an I/O register is modified as a function of itself (e.g., `MOVF PORTA, 1`), the value used will be that value present on the pins themselves. For example, if the data latch is '1' for a pin configured as input and is driven low by an external device, the data will be written back with a '0'.

- 2:** If this instruction is executed on the TMR0 register (and where applicable, d = 1), the prescaler will be cleared if assigned to the Timer0 module.
- 3:** If the Program Counter (PC) is modified, or a conditional test is true, the instruction requires two cycles. The second cycle is executed as an NOP.

## 29.2 Instruction Descriptions

### **ADDLW**      **Add literal and W**

**Syntax:**      [ *label* ] ADDLW    *k*

**Operands:**     $0 \leq k \leq 255$

**Operation:**     $(W) + k \rightarrow (W)$

**Status Affected:**    C, DC, Z

**Description:**    The contents of the W register are added to the eight-bit literal 'k' and the result is placed in the W register.

### **BCF**            **Bit Clear f**

**Syntax:**      [ *label* ] BCF    *f*,*b*

**Operands:**     $0 \leq f \leq 127$   
 $0 \leq b \leq 7$

**Operation:**     $0 \rightarrow (f<b>)$

**Status Affected:**    None

**Description:**    Bit 'b' in register 'f' is cleared.

### **ADDWF**        **Add W and f**

**Syntax:**      [ *label* ] ADDWF    *f*,*d*

**Operands:**     $0 \leq f \leq 127$   
 $d \in [0,1]$

**Operation:**     $(W) + (f) \rightarrow (\text{destination})$

**Status Affected:**    C, DC, Z

**Description:**    Add the contents of the W register with register 'f'. If 'd' is '0', the result is stored in the W register. If 'd' is '1', the result is stored back in register 'f'.

### **BSF**            **Bit Set f**

**Syntax:**      [ *label* ] BSF    *f*,*b*

**Operands:**     $0 \leq f \leq 127$   
 $0 \leq b \leq 7$

**Operation:**     $1 \rightarrow (f<b>)$

**Status Affected:**    None

**Description:**    Bit 'b' in register 'f' is set.

### **ANDLW**        **AND literal with W**

**Syntax:**      [ *label* ] ANDLW    *k*

**Operands:**     $0 \leq k \leq 255$

**Operation:**     $(W) .\text{AND.} (k) \rightarrow (W)$

**Status Affected:**    Z

**Description:**    The contents of W register are AND'ed with the eight-bit literal 'k'. The result is placed in the W register.

### **BTFSC**        **Bit Test f, Skip if Clear**

**Syntax:**      [ *label* ] BTFSC    *f*,*b*

**Operands:**     $0 \leq f \leq 127$   
 $0 \leq b \leq 7$

**Operation:**    skip if  $(f<b>) = 0$

**Status Affected:**    None

**Description:**    If bit 'b' in register 'f' is '1', the next instruction is executed. If bit 'b' in register 'f' is '0', the next instruction is discarded, and an NOP is executed instead, making this a two-cycle instruction.

### **ANDWF**        **AND W with f**

**Syntax:**      [ *label* ] ANDWF    *f*,*d*

**Operands:**     $0 \leq f \leq 127$   
 $d \in [0,1]$

**Operation:**     $(W) .\text{AND.} (f) \rightarrow (\text{destination})$

**Status Affected:**    Z

**Description:**    AND the W register with register 'f'. If 'd' is '0', the result is stored in the W register. If 'd' is '1', the result is stored back in register 'f'.

# MCP19110/11

---

<b>BTFSF</b>	<b>Bit Test f, Skip if Set</b>
Syntax:	[ <i>label</i> ] BTFSF f,b
Operands:	$0 \leq f \leq 127$ $0 \leq b < 7$
Operation:	skip if (f<b>) = 1
Status Affected:	None
Description:	If bit 'b' in register 'f' is '0', the next instruction is executed. If bit 'b' is '1', then the next instruction is discarded and an NOP is executed instead, making this a two-cycle instruction.

<b>CLRWDT</b>	<b>Clear Watchdog Timer</b>
Syntax:	[ <i>label</i> ] CLRWDT
Operands:	None
Operation:	00h → WDT 0 → WDT prescaler, 1 → $\overline{TO}$ 1 → $\overline{PD}$
Status Affected:	$\overline{TO}$ , $\overline{PD}$
Description:	CLRWDT instruction resets the Watchdog Timer. It also resets the prescaler of the WDT. Status bits $\overline{TO}$ and $\overline{PD}$ are set.

<b>CALL</b>	<b>Call Subroutine</b>
Syntax:	[ <i>label</i> ] CALL k
Operands:	$0 \leq k \leq 2047$
Operation:	(PC)+ 1 → TOS, k → PC<10:0>, (PCLATH<4:3>) → PC<12:11>
Status Affected:	None
Description:	Call Subroutine. First, return address (PC + 1) is pushed onto the stack. The eleven-bit immediate address is loaded into PC bits <10:0>. The upper bits of the PC are loaded from PCLATH. CALL is a two-cycle instruction.

<b>COMF</b>	<b>Complement f</b>
Syntax:	[ <i>label</i> ] COMF f,d
Operands:	$0 \leq f \leq 127$ $d \in [0,1]$
Operation:	( $\bar{f}$ ) → (destination)
Status Affected:	Z
Description:	The contents of register 'f' are complemented. If 'd' is '0', the result is stored in W. If 'd' is '1', the result is stored back in register 'f'.

<b>CLRF</b>	<b>Clear f</b>
Syntax:	[ <i>label</i> ] CLRF f
Operands:	$0 \leq f \leq 127$
Operation:	00h → (f) 1 → Z
Status Affected:	Z
Description:	The contents of register 'f' are cleared and the Z bit is set.

<b>DECF</b>	<b>Decrement f</b>
Syntax:	[ <i>label</i> ] DECF f,d
Operands:	$0 \leq f \leq 127$ $d \in [0,1]$
Operation:	(f) - 1 → (destination)
Status Affected:	Z
Description:	Decrement register 'f'. If 'd' is '0', the result is stored in the W register. If 'd' is '1', the result is stored back in register 'f'.

<b>CLRW</b>	<b>Clear W</b>
Syntax:	[ <i>label</i> ] CLRW
Operands:	None
Operation:	00h → (W) 1 → Z
Status Affected:	Z
Description:	W register is cleared. Zero bit (Z) is set.

---

## DECFSZ      Decrement f, Skip if 0

---

Syntax:      [ *label* ] DECFSZ f,d

Operands:     $0 \leq f \leq 127$   
 $d \in [0,1]$

Operation:    (f) - 1 → (destination);  
 skip if result = 0

Status Affected: None

Description:    The contents of register 'f' are decremented. If 'd' is '0', the result is placed in the W register. If 'd' is '1', the result is placed back in register 'f'.  
 If the result is '1', the next instruction is executed. If the result is '0', then an NOP is executed instead, making it a two-cycle instruction.

---

## INCFSZ      Increment f, Skip if 0

---

Syntax:      [ *label* ] INCFSZ f,d

Operands:     $0 \leq f \leq 127$   
 $d \in [0,1]$

Operation:    (f) + 1 → (destination),  
 skip if result = 0

Status Affected: None

Description:    The contents of register 'f' are incremented. If 'd' is '0', the result is placed in the W register. If 'd' is '1', the result is placed back in register 'f'.  
 If the result is '1', the next instruction is executed. If the result is '0', an NOP is executed instead, making it a two-cycle instruction.

---

## GOTO      Unconditional Branch

---

Syntax:      [ *label* ] GOTO k

Operands:     $0 \leq k \leq 2047$

Operation:     $k \rightarrow PC<10:0>$   
 $PCLATH<4:3> \rightarrow PC<12:11>$

Status Affected: None

Description:    GOTO is an unconditional branch. The eleven-bit immediate value is loaded into PC bits <10:0>. The upper bits of PC are loaded from PCLATH<4:3>. GOTO is a two-cycle instruction.

---

## IORLW      Inclusive OR literal with W

---

Syntax:      [ *label* ] IORLW k

Operands:     $0 \leq k \leq 255$

Operation:    (W) .OR. k → (W)

Status Affected: Z

Description:    The contents of the W register are OR'ed with the eight-bit literal 'k'. The result is placed in the W register.

---

## INCF      Increment f

---

Syntax:      [ *label* ] INCF f,d

Operands:     $0 \leq f \leq 127$   
 $d \in [0,1]$

Operation:    (f) + 1 → (destination)

Status Affected: Z

Description:    The contents of register 'f' are incremented. If 'd' is '0', the result is placed in the W register. If 'd' is '1', the result is placed back in register 'f'.

---

## IORWF      Inclusive OR W with f

---

Syntax:      [ *label* ] IORWF f,d

Operands:     $0 \leq f \leq 127$   
 $d \in [0,1]$

Operation:    (W) .OR. (f) → (destination)

Status Affected: Z

Description:    Inclusive OR the W register with register 'f'. If 'd' is '0', the result is placed in the W register. If 'd' is '1', the result is placed back in register 'f'.

# MCP19110/11

---

## **MOVF**            **Move f**

---

Syntax:            [*label*] MOVF f,d  
Operands:         $0 \leq f \leq 127$   
                     $d \in [0,1]$   
Operation:        (f) → (dest)  
Status Affected: Z  
Description:      The contents of register 'f' is moved to a destination dependent upon the status of 'd'. If d = 0, destination is W register. If d = 1, the destination is file register 'f' itself. d = 1 is useful to test a file register since Status flag Z is affected.

Words:            1  
Cycles:            1

Example:        MOVF    FSR, 0

After Instruction  
                    W = value in  
                    FSR register  
                    Z = 1

## **MOVLW**           **Move literal to W**

---

Syntax:           [*label*] MOVLW k  
Operands:         $0 \leq k \leq 255$   
Operation:         $k \rightarrow (W)$   
Status Affected: None  
Description:      The eight-bit literal 'k' is loaded into W register. The "don't cares" will assemble as '0's.

Words:            1  
Cycles:            1

Example:        MOVLW    0x5A

After Instruction  
                    W = 0x5A

## **MOVWF**           **Move W to f**

---

Syntax:           [*label*] MOVWF f  
Operands:         $0 \leq f \leq 127$   
Operation:        (W) → (f)  
Status Affected: None  
Description:      Move data from W register to register 'f'.

Words:            1  
Cycles:            1

Example:        MOVW    OPTION  
                    F

Before Instruction  
                    OPTION = 0xFF  
                    W        = 0x4F

After Instruction  
                    OPTION = 0x4F  
                    W        = 0x4F

## **NOP**                **No Operation**

---

Syntax:           [*label*] NOP  
Operands:        None  
Operation:        No operation  
Status Affected: None  
Description:      No operation.

Words:            1  
Cycles:            1

Example:        NOP

---

<b>RETFIE</b>	<b>Return from Interrupt</b>
Syntax:	[ <i>label</i> ] RETFIE
Operands:	None
Operation:	TOS → PC, 1 → GIE
Status Affected:	None
Description:	Return from Interrupt. Stack is POPed and Top-of-Stack (TOS) is loaded in the PC. Interrupts are enabled by setting Global Interrupt Enable bit, GIE (INT-CON<7>). This is a two-cycle instruction.
Words:	1
Cycles:	2
<u>Example:</u>	RETFIE  After Interrupt PC = TOS GIE = 1

---

<b>RETLW</b>	<b>Return with literal in W</b>
Syntax:	[ <i>label</i> ] RETLW k
Operands:	0 ≤ k ≤ 255
Operation:	k → (W); TOS → PC
Status Affected:	None
Description:	The W register is loaded with the eight-bit literal 'k'. The program counter is loaded from the top of the stack (the return address). This is a two-cycle instruction.
Words:	1
Cycles:	2
<u>Example:</u>	CALL TABLE;W contains ;table offset ;value  GOTO DONE  TABLE • • ADDWF PC ;W = offset RETLW k1 ;Begin table RETLW k2 ; • • • RETLW kn ;End of table  DONE  Before Instruction W = 0x07 After Instruction W = value of k8

---

<b>RETURN</b>	<b>Return from Subroutine</b>
Syntax:	[ <i>label</i> ] RETURN
Operands:	None
Operation:	TOS → PC
Status Affected:	None
Description:	Return from subroutine. The stack is POPed and the top of the stack (TOS) is loaded into the program counter. This is a two-cycle instruction.

---

# MCP19110/11

## RLF Rotate Left f through Carry

**Syntax:** [ *label* ] RLF f,d  
**Operands:**  $0 \leq f \leq 127$   
 $d \in [0,1]$   
**Operation:** See description below  
**Status Affected:** C  
**Description:** The contents of register 'f' are rotated one bit to the left through the Carry flag. If 'd' is '0', the result is placed in the W register. If 'd' is '1', the result is stored back in register 'f'.

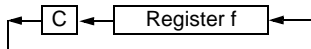

**Words:** 1  
**Cycles:** 1  
**Example:**

```

RLF    REG1,0

Before Instruction
REG1   = 1110
0110
C      = 0

After Instruction
REG1   = 1110
0110
W      = 1100
1100
C      = 1
    
```

## SLEEP Enter Sleep mode

**Syntax:** [ *label* ] SLEEP  
**Operands:** None  
**Operation:** 00h → WDT,  
0 → WDT prescaler,  
1 →  $\overline{TO}$ ,  
0 → PD  
**Status Affected:**  $\overline{TO}$ , PD  
**Description:** The power-down Status bit, PD is cleared. Time-out Status bit,  $\overline{TO}$  is set. Watchdog Timer and its prescaler are cleared. The processor is put into Sleep mode with the oscillator stopped.

## RRF Rotate Right f through Carry

**Syntax:** [ *label* ] RRF f,d  
**Operands:**  $0 \leq f \leq 127$   
 $d \in [0,1]$   
**Operation:** See description below  
**Status Affected:** C  
**Description:** The contents of register 'f' are rotated one bit to the right through the Carry flag. If 'd' is '0', the result is placed in the W register. If 'd' is '1', the result is placed back in register 'f'.

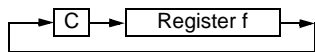

## SUBLW Subtract W from literal

**Syntax:** [ *label* ] SUBLW k  
**Operands:**  $0 \leq k \leq 255$   
**Operation:**  $k - (W) \rightarrow (W)$   
**Status Affected:** C, DC, Z  
**Description:** The W register is subtracted (two's complement method) from the eight-bit literal 'k'. The result is placed in the W register.

Result	Condition
C = 0	$W > k$
C = 1	$W \leq k$
DC = 0	$W\langle 3:0 \rangle > k\langle 3:0 \rangle$
DC = 1	$W\langle 3:0 \rangle \leq k\langle 3:0 \rangle$



**SUBWF**            **Subtract W from f**

---

Syntax:            [ *label* ] SUBWF f,d

Operands:         $0 \leq f \leq 127$   
                        $d \in [0,1]$

Operation:        (f) - (W) → (destination)

Status Affected: C, DC, Z

Description:      Subtract (two's complement method) W register from register 'f'. If 'd' is '0', the result is stored in the W register. If 'd' is '1', the result is stored back in register 'f'.

C = 0	W > f
C = 1	W ≤ f
DC = 0	W<3:0> > f<3:0>
DC = 1	W<3:0> ≤ f<3:0>

**XORWF**            **Exclusive OR W with f**

---

Syntax:            [ *label* ] XORWF f,d

Operands:         $0 \leq f \leq 127$   
                        $d \in [0,1]$

Operation:        (W) .XOR. (f) → (destination)

Status Affected: Z

Description:      Exclusive OR the contents of the W register with register 'f'. If 'd' is '0', the result is stored in the W register. If 'd' is '1', the result is stored back in register 'f'.

**SWAPF**            **Swap Nibbles in f**

---

Syntax:            [ *label* ] SWAPF f,d

Operands:         $0 \leq f \leq 127$   
                        $d \in [0,1]$

Operation:        (f<3:0>) → (destination<7:4>),  
                       (f<7:4>) → (destination<3:0>)

Status Affected: None

Description:      The upper and lower nibbles of register 'f' are exchanged. If 'd' is '0', the result is placed in the W register. If 'd' is '1', the result is placed in register 'f'.

**XORLW**            **Exclusive OR literal with W**

---

Syntax:            [ *label* ] XORLW k

Operands:         $0 \leq k \leq 255$

Operation:        (W) .XOR. k → (W)

Status Affected: Z

Description:      The contents of the W register are XOR'ed with the eight-bit literal 'k'. The result is placed in the W register.

# MCP19110/11

---

NOTES:

## 30.0 DEVELOPMENT SUPPORT

The PIC<sup>®</sup> microcontrollers (MCU) and dsPIC<sup>®</sup> digital signal controllers (DSC) are supported with a full range of software and hardware development tools:

- Integrated Development Environment
  - MPLAB<sup>®</sup> X IDE Software
- Compilers/Assemblers/Linkers
  - MPLAB XC Compiler
  - MPASM<sup>™</sup> Assembler
  - MPLINK<sup>™</sup> Object Linker/  
MPLIB<sup>™</sup> Object Librarian
  - MPLAB Assembler/Linker/Librarian for  
Various Device Families
- Simulators
  - MPLAB X SIM Software Simulator
- Emulators
  - MPLAB REAL ICE<sup>™</sup> In-Circuit Emulator
- In-Circuit Debuggers/Programmers
  - MPLAB ICD 3
  - PICKit<sup>™</sup> 3
- Device Programmers
  - MPLAB PM3 Device Programmer
- Low-Cost Demonstration/Development Boards,  
Evaluation Kits and Starter Kits
- Third-party Development Tools

## 30.1 MPLAB X Integrated Development Environment Software

The MPLAB X IDE is a single, unified graphical user interface for Microchip and third-party software, and hardware development tool that runs on Windows<sup>®</sup>, Linux and Mac OS<sup>®</sup> X. Based on the NetBeans IDE, MPLAB X IDE is an entirely new IDE with a host of free software components and plug-ins for high-performance application development and debugging. Moving between tools and upgrading from software simulators to hardware debugging and programming tools is simple with the seamless user interface.

With complete project management, visual call graphs, a configurable watch window and a feature-rich editor that includes code completion and context menus, MPLAB X IDE is flexible and friendly enough for new users. With the ability to support multiple tools on multiple projects with simultaneous debugging, MPLAB X IDE is also suitable for the needs of experienced users.

Feature-Rich Editor:

- Color syntax highlighting
- Smart code completion makes suggestions and provides hints as you type
- Automatic code formatting based on user-defined rules
- Live parsing

User-Friendly, Customizable Interface:

- Fully customizable interface: toolbars, toolbar buttons, windows, window placement, etc.
- Call graph window

Project-Based Workspaces:

- Multiple projects
- Multiple tools
- Multiple configurations
- Simultaneous debugging sessions

File History and Bug Tracking:

- Local file history feature
- Built-in support for Bugzilla issue tracker

## 30.2 MPLAB XC Compilers

The MPLAB XC Compilers are complete ANSI C compilers for all of Microchip's 8, 16, and 32-bit MCU and DSC devices. These compilers provide powerful integration capabilities, superior code optimization and ease of use. MPLAB XC Compilers run on Windows, Linux or MAC OS X.

For easy source level debugging, the compilers provide debug information that is optimized to the MPLAB X IDE.

The free MPLAB XC Compiler editions support all devices and commands, with no time or memory restrictions, and offer sufficient code optimization for most applications.

MPLAB XC Compilers include an assembler, linker and utilities. The assembler generates relocatable object files that can then be archived or linked with other relocatable object files and archives to create an executable file. MPLAB XC Compiler uses the assembler to produce its object file. Notable features of the assembler include:

- Support for the entire device instruction set
- Support for fixed-point and floating-point data
- Command-line interface
- Rich directive set
- Flexible macro language
- MPLAB X IDE compatibility

## 30.3 MPASM Assembler

The MPASM Assembler is a full-featured, universal macro assembler for PIC10/12/16/18 MCUs.

The MPASM Assembler generates relocatable object files for the MPLINK Object Linker, Intel® standard HEX files, MAP files to detail memory usage and symbol reference, absolute LST files that contain source lines and generated machine code, and COFF files for debugging.

The MPASM Assembler features include:

- Integration into MPLAB X IDE projects
- User-defined macros to streamline assembly code
- Conditional assembly for multipurpose source files
- Directives that allow complete control over the assembly process

## 30.4 MPLINK Object Linker/ MPLIB Object Librarian

The MPLINK Object Linker combines relocatable objects created by the MPASM Assembler. It can link relocatable objects from precompiled libraries, using directives from a linker script.

The MPLIB Object Librarian manages the creation and modification of library files of precompiled code. When a routine from a library is called from a source file, only the modules that contain that routine will be linked in with the application. This allows large libraries to be used efficiently in many different applications.

The object linker/library features include:

- Efficient linking of single libraries instead of many smaller files
- Enhanced code maintainability by grouping related modules together
- Flexible creation of libraries with easy module listing, replacement, deletion and extraction

## 30.5 MPLAB Assembler, Linker and Librarian for Various Device Families

MPLAB Assembler produces relocatable machine code from symbolic assembly language for PIC24, PIC32 and dsPIC DSC devices. MPLAB XC Compiler uses the assembler to produce its object file. The assembler generates relocatable object files that can then be archived or linked with other relocatable object files and archives to create an executable file. Notable features of the assembler include:

- Support for the entire device instruction set
- Support for fixed-point and floating-point data
- Command-line interface
- Rich directive set
- Flexible macro language
- MPLAB X IDE compatibility

## 30.6 MPLAB X SIM Software Simulator

The MPLAB X SIM Software Simulator allows code development in a PC-hosted environment by simulating the PIC MCUs and dsPIC DSCs on an instruction level. On any given instruction, the data areas can be examined or modified and stimuli can be applied from a comprehensive stimulus controller. Registers can be logged to files for further run-time analysis. The trace buffer and logic analyzer display extend the power of the simulator to record and track program execution, actions on I/O, most peripherals and internal registers.

The MPLAB X SIM Software Simulator fully supports symbolic debugging using the MPLAB XC Compilers, and the MPASM and MPLAB Assemblers. The software simulator offers the flexibility to develop and debug code outside of the hardware laboratory environment, making it an excellent, economical software development tool.

## 30.7 MPLAB REAL ICE In-Circuit Emulator System

The MPLAB REAL ICE In-Circuit Emulator System is Microchip's next generation high-speed emulator for Microchip Flash DSC and MCU devices. It debugs and programs all 8, 16 and 32-bit MCU, and DSC devices with the easy-to-use, powerful graphical user interface of the MPLAB X IDE.

The emulator is connected to the design engineer's PC using a high-speed USB 2.0 interface and is connected to the target with either a connector compatible with in-circuit debugger systems (RJ-11) or with the new high-speed, noise tolerant, Low-Voltage Differential Signal (LVDS) interconnection (CAT5).

The emulator is field upgradeable through future firmware downloads in MPLAB X IDE. MPLAB REAL ICE offers significant advantages over competitive emulators including full-speed emulation, run-time variable watches, trace analysis, complex breakpoints, logic probes, a ruggedized probe interface and long (up to three meters) interconnection cables.

## 30.8 MPLAB ICD 3 In-Circuit Debugger System

The MPLAB ICD 3 In-Circuit Debugger System is Microchip's most cost-effective, high-speed hardware debugger/programmer for Microchip Flash DSC and MCU devices. It debugs and programs PIC Flash microcontrollers and dsPIC DSCs with the powerful, yet easy-to-use graphical user interface of the MPLAB IDE.

The MPLAB ICD 3 In-Circuit Debugger probe is connected to the design engineer's PC using a high-speed USB 2.0 interface and is connected to the target with a connector compatible with the MPLAB ICD 2 or MPLAB REAL ICE systems (RJ-11). MPLAB ICD 3 supports all MPLAB ICD 2 headers.

## 30.9 PICkit 3 In-Circuit Debugger/Programmer

The MPLAB PICkit 3 allows debugging and programming of PIC and dsPIC Flash microcontrollers at a most affordable price point using the powerful graphical user interface of the MPLAB IDE. The MPLAB PICkit 3 is connected to the design engineer's PC using a full-speed USB interface and can be connected to the target via a Microchip debug (RJ-11) connector (compatible with MPLAB ICD 3 and MPLAB REAL ICE). The connector uses two device I/O pins and the Reset line to implement in-circuit debugging and In-Circuit Serial Programming™ (ICSP™).

## 30.10 MPLAB PM3 Device Programmer

The MPLAB PM3 Device Programmer is a universal, CE compliant device programmer with programmable voltage verification at VDDMIN and VDDMAX for maximum reliability. It features a large LCD display (128 x 64) for menus and error messages, and a modular, detachable socket assembly to support various package types. The ICSP cable assembly is included as a standard item. In Stand-Alone mode, the MPLAB PM3 Device Programmer can read, verify and program PIC devices without a PC connection. It can also set code protection in this mode. The MPLAB PM3 connects to the host PC via an RS-232 or USB cable. The MPLAB PM3 has high-speed communications and optimized algorithms for quick programming of large memory devices, and incorporates an MMC card for file storage and data applications.

## 30.11 Demonstration/Development Boards, Evaluation Kits, and Starter Kits

A wide variety of demonstration, development and evaluation boards for various PIC MCUs and dsPIC DSCs allows quick application development on fully functional systems. Most boards include prototyping areas for adding custom circuitry and provide application firmware and source code for examination and modification.

The boards support a variety of features, including LEDs, temperature sensors, switches, speakers, RS-232 interfaces, LCD displays, potentiometers and additional EEPROM memory.

The demonstration and development boards can be used in teaching environments, for prototyping custom circuits and for learning about various microcontroller applications.

In addition to the PICDEM™ and dsPICDEM™ demonstration/development board series of circuits, Microchip has a line of evaluation kits and demonstration software for analog filter design, KEELOQ® security ICs, CAN, IrDA®, PowerSmart battery management, SEEVAL® evaluation system, Sigma-Delta ADC, flow rate sensing, plus many more.

Also available are starter kits that contain everything needed to experience the specified device. This usually includes a single application and debug capability, all on one board.

Check the Microchip web page ([www.microchip.com](http://www.microchip.com)) for the complete list of demonstration, development and evaluation kits.

## 30.12 Third-Party Development Tools

Microchip also offers a great collection of tools from third-party vendors. These tools are carefully selected to offer good value and unique functionality.

- Device Programmers and Gang Programmers from companies, such as SoftLog and CCS
- Software Tools from companies, such as Gimpel and Trace Systems
- Protocol Analyzers from companies, such as Saleae and Total Phase
- Demonstration Boards from companies, such as MikroElektronika, Digilent® and Olimex
- Embedded Ethernet Solutions from companies, such as EZ Web Lynx, WIZnet and IPLogika®

## 31.0 PACKAGING INFORMATION

### 31.1 Package Marking Information

24-Lead QFN (4x4x0.9 mm) (MCP19110 only)

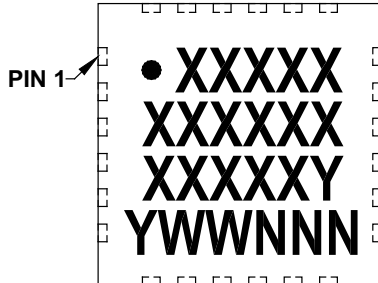

Example

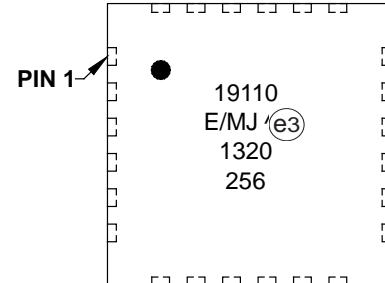

28-Lead QFN (5x5x0.9 mm)(MCP19111 only)

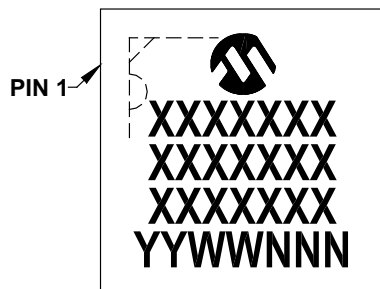

Example

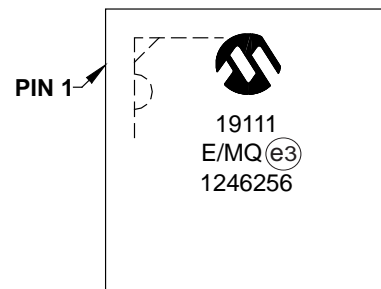

<b>Legend:</b>	XX...X	Customer-specific information
	Y	Year code (last digit of calendar year)
	YY	Year code (last 2 digits of calendar year)
	WW	Week code (week of January 1 is week '01')
	NNN	Alphanumeric traceability code
	(e3)	RoHS Compliant JEDEC designator for Matte Tin (Sn)
	*	This package is RoHS Compliant. The RoHS Compliant JEDEC designator ((e3)) can be found on the outer packaging for this package.

**Note:** In the event the full Microchip part number cannot be marked on one line, it will be carried over to the next line, thus limiting the number of available characters for customer-specific information.

# MCP19110/11

## 24-Lead Plastic Quad Flat, No Lead Package (MJ) – 4x4x0.9 mm Body [QFN]

**Note:** For the most current package drawings, please see the Microchip Packaging Specification located at <http://www.microchip.com/packaging>

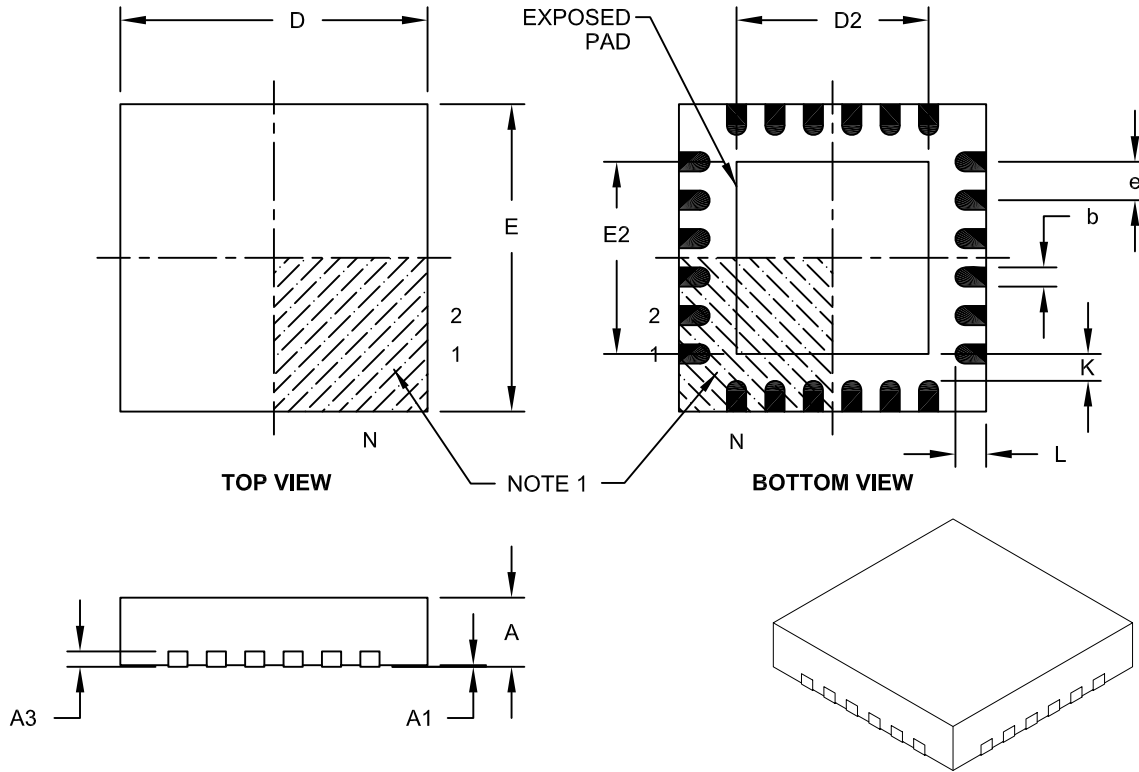

Dimension Limits	Units	MILLIMETERS		
		MIN	NOM	MAX
Number of Pins	N	24		
Pitch	e	0.50 BSC		
Overall Height	A	0.80	0.85	0.90
Standoff	A1	0.00	0.02	0.05
Contact Thickness	A3	0.20 REF		
Overall Width	E	4.00 BSC		
Exposed Pad Width	E2	2.40	2.50	2.60
Overall Length	D	4.00 BSC		
Exposed Pad Length	D2	2.40	2.50	2.60
Contact Width	b	0.20	0.25	0.30
Contact Length	L	0.30	0.40	0.50
Contact-to-Exposed Pad	K	0.20	-	-

**Notes:**

- Pin 1 visual index feature may vary, but must be located within the hatched area.
- Package is saw singulated.
- Dimensioning and tolerancing per ASME Y14.5M.

BSC: Basic Dimension. Theoretically exact value shown without tolerances.

REF: Reference Dimension, usually without tolerance, for information purposes only.

Microchip Technology Drawing C04-143A



## 24-Lead Plastic Quad Flat, No Lead Package (MJ) - 4x4 mm Body [QFN]

**Note:** For the most current package drawings, please see the Microchip Packaging Specification located at <http://www.microchip.com/packaging>

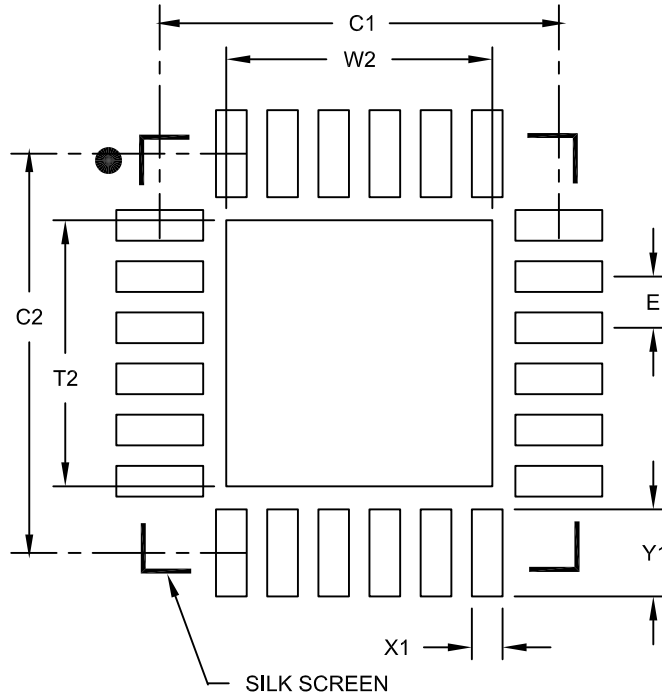

RECOMMENDED LAND PATTERN

Dimension Limits	Units	MILLIMETERS		
		MIN	NOM	MAX
Contact Pitch	E	0.50 BSC		
Optional Center Pad Width	W2			2.60
Optional Center Pad Length	T2			2.60
Contact Pad Spacing	C1		3.90	
Contact Pad Spacing	C2		3.90	
Contact Pad Width	X1			0.30
Contact Pad Length	Y1			0.85

**Notes:**

1. Dimensioning and tolerancing per ASME Y14.5M

BSC: Basic Dimension. Theoretically exact value shown without tolerances.

Microchip Technology Drawing No. C04-2143B

# MCP19110/11

## 28-Lead Plastic Quad Flat, No Lead Package (MQ) – 5x5x0.9 mm Body [QFN]

**Note:** For the most current package drawings, please see the Microchip Packaging Specification located at <http://www.microchip.com/packaging>

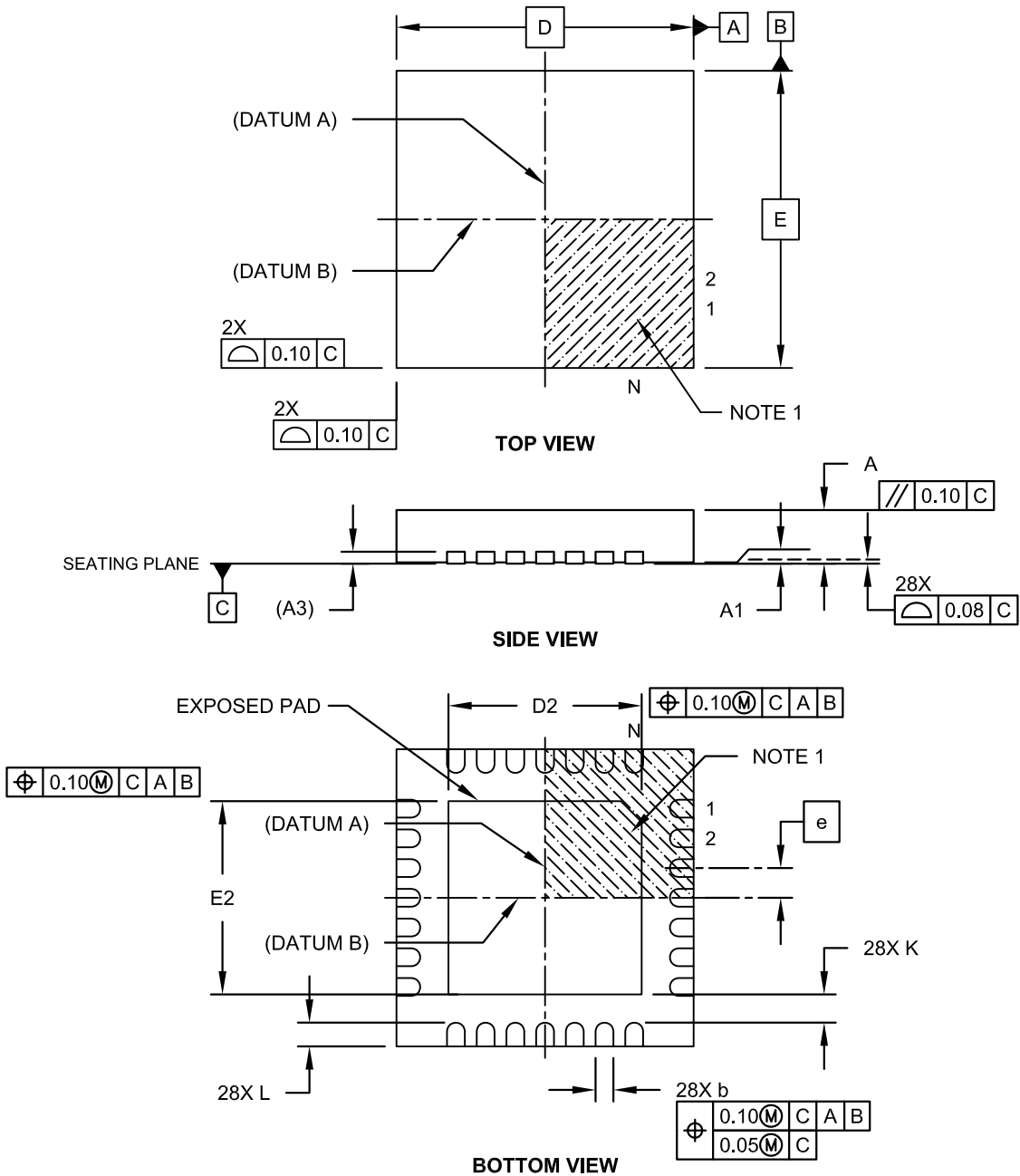

Microchip Technology Drawing C04-140B Sheet 1 of 2

## 28-Lead Plastic Quad Flat, No Lead Package (MQ) – 5x5x0.9 mm Body [QFN]

**Note:** For the most current package drawings, please see the Microchip Packaging Specification located at <http://www.microchip.com/packaging>

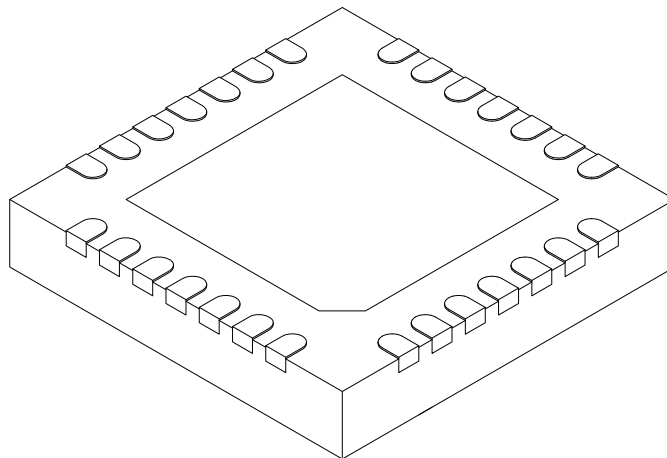

Dimension Limits	Units	MILLIMETERS		
		MIN	NOM	MAX
Number of Pins	N	28		
Pitch	e	0.50 BSC		
Overall Height	A	0.80	0.90	1.00
Standoff	A1	0.00	0.02	0.05
Contact Thickness	A3	0.20 REF		
Overall Width	E	5.00 BSC		
Exposed Pad Width	E2	3.15	3.25	3.35
Overall Length	D	5.00 BSC		
Exposed Pad Length	D2	3.15	3.25	3.35
Contact Width	b	0.18	0.25	0.30
Contact Length	L	0.35	0.40	0.45
Contact-to-Exposed Pad	K	0.20	-	-

**Notes:**

- Pin 1 visual index feature may vary, but must be located within the hatched area.
- Package is saw singulated.
- Dimensioning and tolerancing per ASME Y14.5M.  
 BSC: Basic Dimension. Theoretically exact value shown without tolerances.  
 REF: Reference Dimension, usually without tolerance, for information purposes only.

Microchip Technology Drawing C04-140B Sheet 2 of 2

# MCP19110/11

## 28-Lead Plastic Quad Flat, No Lead Package (MQ) – 5x5 mm Body [QFN] Land Pattern With 0.55 mm Contact Length

**Note:** For the most current package drawings, please see the Microchip Packaging Specification located at <http://www.microchip.com/packaging>

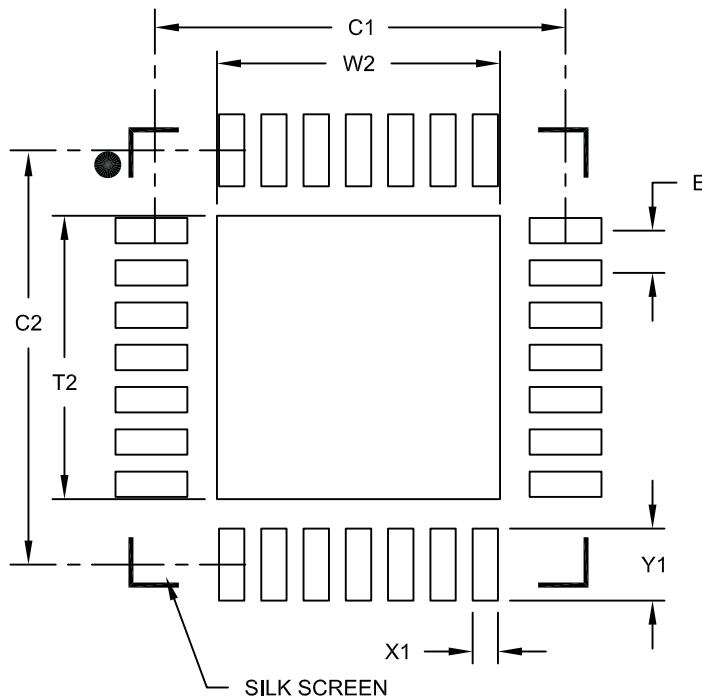

RECOMMENDED LAND PATTERN

Dimension Limits	Units	MILLIMETERS		
		MIN	NOM	MAX
Contact Pitch	E	0.50 BSC		
Optional Center Pad Width	W2			3.35
Optional Center Pad Length	T2			3.35
Contact Pad Spacing	C1		4.90	
Contact Pad Spacing	C2		4.90	
Contact Pad Width (X28)	X1			0.30
Contact Pad Length (X28)	Y1			0.85

**Notes:**

1. Dimensioning and tolerancing per ASME Y14.5M

BSC: Basic Dimension. Theoretically exact value shown without tolerances.

Microchip Technology Drawing C04-2140A

## APPENDIX A: REVISION HISTORY

### Revision B (June 2013)

The following is the list of modifications:

1. Added new device MCP19110 to the family and the related information across the document.
2. Updated information in Features section.
3. Added pinout diagram and pin summary table for the MCP19110 device.
4. Updated [Figure 1-1](#).
5. Updated [Section 2.0 “Pin Description”](#).
6. Updated [Section 4.3 “Thermal Specifications”](#).
7. Added new [Section 28.2 “In-Circuit Debugger”](#).
8. Updated [Section 31.1 “Package Marking Information”](#).
9. Updated [Product Identification System](#).
10. Fixed minor typographical errors.

### Revision A (January 2013)

- Original Release of this Document.

# MCP19110/11

---

NOTES:

## INDEX

### A

A/D	
Specifications	3, 5, 33
A/D Conversion	127
Requirements	34
Timing	34, 35
Absolute Maximum Ratings	23
AC Characteristics	30
ACKSTAT	172
ACKSTAT Status Flag	172
ADC	125
Acquisition Requirements	131
Associated Registers	133
Block Diagram	125
Calculating Acquisition Time	131
Channel Selection	126
Configuration	126
Configuring Interrupt	128
Conversion Clock	126
Conversion Procedure	128
Internal Sampling Switch (RSS) IMPEDANCE	131
Interrupts	127
Operation	128
Operation During Sleep	128
Port Configuration	126
Register Definitions	129
Source Impedance	131
Special Event Trigger	128
ADCON0 Register	129
ADCON1 Register	130
ADRESH Register (ADFM = 0)	130
ADRESL Register (ADFM = 0)	130
Alternate Pin Function	112
Analog Blocks Enable Control	51
Analog Peripheral Control	49
Analog-to-Digital Converter. See ADC	
ANSELA Register	115
ANSELB Register	118
APFCON Register	112
Assembler	
MPASM Assembler	204

### B

Bench Testing	
Analog Bench Test Control	57
System	57
BF	172, 174
BF Status Flag	172, 174
Block Diagrams	
ADC	125
ADC Transfer Function	132
Analog Input Model	132
Generic I/O Port	111
Interrupt Logic	94
MCLR Circuit	86
MCP19110/11 Synchronous Buck Block Diagram	10
MSSP (I <sup>2</sup> C Master Mode)	147
MSSP (I <sup>2</sup> C Slave Mode)	148
On-Chip Reset Circuit	85

Simplified PWM	144
Timer0	135
Timer1	137
Timer2	140
Watchdog Timer	103

### C

C Compilers	
MPLAB C18	204
Calibration Word	
Associated Registers	84
Capture/Compare/PWM	143, 145
Clock Switching	84
Code Examples	
A/D Conversion	128
Assigning Prescaler to Timer0	136
Assigning Prescaler to WDT	136
Initializing PORTA	111
Saving Status and W Registers in RAM	100
Compensation	18
Compensation Setting	43
Computed Function Calls	78
Computed GOTO	78
Current	
Measurement Control	51
Current Sense	18, 40, 41
Customer Change Notification Service	221
Customer Support	221

### D

Data Memory	70
Data Memory Map	72
DC and AC Characteristics	53
Graphs and Tables	53
DC Characteristics	30
Development Support	203
Device	
Configuration	37, 81
Code Protection	82
Configuration Word	81
ID Locations	82
User ID	82
Write Protection	82
Device Calibration	59
Calibration Word 1	59
Calibration Word 2	60
Calibration Word 3	61
Calibration Word 4	62
Calibration Word 5	63
Calibration Word 6	64
Calibration Word 7	65
Device Overview	9
Digital Electrical Characteristics	29
Diode Emulation Mode	49

### E

ECCP/CCP. See Enhanced Capture/Compare/PWM	
Electrical Characteristics	23, 24
Errata	7
External Clock	30

# MCP19110/11

<b>F</b>			
Features			
Miscellaneous .....	21		
Protection .....	20		
Synchronous Buck .....	1		
Firmware Instructions .....	193		
Flash Program Memory Control .....	105		
Operation During Code Protect .....	109		
Operation during write Protect .....	109		
Protecting .....	109		
Reading .....	108		
Writing to .....	109		
Flash Program Memory Control Registers .....	106		
<b>H</b>			
High-Side Drive Strength .....	49		
<b>I</b>			
I/O			
Ports .....	111		
I <sup>2</sup> C Mode (MSSPx)			
Acknowledge Sequence .....	152		
Acknowledge Sequence Timing .....	176		
Associated Registers .....	182		
Bus Collision			
During a Repeated Start Condition .....	180		
During a Start Condition .....	178		
During a Stop Condition .....	181		
Effects of a Reset .....	177		
I <sup>2</sup> C Clock Rate w/BRG .....	183		
Master Mode .....	169		
Clock Arbitration .....	169		
Operation .....	169		
Reception .....	174		
Start Condition Timing .....	170, 171		
Transmission .....	172		
Multi-Master Communication, Bus Collision and Arbitra- tion .....	177		
Multi-Master Mode .....	177		
Operation .....	150		
Overview .....	148		
Read/Write Bit Information (R/W Bit) .....	153		
Slave Mode			
10-bit Address Reception .....	163		
Bus Collision .....	159		
Clock Synchronization .....	167		
General Call Address Support .....	168		
Operation .....	153		
SSPMSKx Register .....	168		
Transmission .....	159		
Sleep Operation .....	177		
Stop Condition Timing .....	176		
In-Circuit Serial Programming (ICSP) .....	191		
Common Programming Interfaces .....	191		
In-Circuit Debugger .....	192		
Indirect Addressing .....	78		
Input .....	24		
Type .....	12		
Undervoltage Lockout .....	20, 37		
Instruction Format .....	193		
Instruction Set .....	193		
ADDLW .....	195		
ADDWF .....	195		
ANDLW .....	195		
ANDWF .....	195		
BCF .....	195		
BSF .....	195		
BTFSC .....	195		
BTFSS .....	196		
CALL .....	196		
CLRF .....	196		
CLRW .....	196		
CLRWDT .....	196		
COMF .....	196		
DECF .....	196		
DECFSZ .....	197		
GOTO .....	197		
INCF .....	197		
INCFSZ .....	197		
IORLW .....	197		
IORWF .....	197		
MOVF .....	198		
MOVLW .....	198		
MOVWF .....	198		
NOP .....	198		
RETFIE .....	199		
RETLW .....	199		
RETURN .....	199		
RLF .....	200		
RRF .....	200		
SLEEP .....	200		
SUBLW .....	200		
SUBWF .....	201		
SWAPF .....	201		
XORLW .....	201		
XORWF .....	201		
Summary Table .....	194		
Internal Sampling Switch (Rss) IMPEDANCE .....	131		
Internal Synchronous Driver .....	17		
Internal Temperature Indicator Module .....	123		
Circuit Operation .....	123		
Temperature Output .....	123		
Internal Temperature Measurement Control .....	51		
Internet Address .....	221		
Interrupt-on-Change .....	121		
Associated Registers .....	122		
Clearing Interrupt Flags .....	121		
Enabling the Module .....	121		
Operation in Sleep .....	121		
Pin Configuration .....	121		
Registers .....	122		
Interrupts			
ADC .....	128		
Associated Registers .....	99		
Context Saving .....	100		
Control Registers .....	95		
RA2/INT .....	93		
TMR1 .....	138		
<b>L</b>			
Linear Regulators .....	17		



## M

MASTER Error Signal Gain .....	45
Master Synchronous Serial Port. <i>See</i> MSSPx	
MCLR .....	86
Internal .....	86
Memory Organization .....	69
Data .....	70
Program .....	69
Microchip Internet Web Site .....	221
MOSFET .....	15, 16, 17, 38, 46, 49, 57, 67
Driver Dead Time .....	17
MOSFET Driver	
Dead Time .....	49
Programmable Dead Time .....	46
MPLAB ASM30 Assembler, Linker, Librarian .....	204
MPLAB Integrated Development Environment Software ..	203
MPLAB PM3 Device Programmer .....	205
MPLAB REAL ICE In-Circuit Emulator System .....	205
MPLINK Object Linker/MPLIB Object Librarian .....	204
MSSPx .....	147
Arbitration .....	150
Baud Rate Generator .....	183
Clock Stretching .....	150
I <sup>2</sup> C Bus Terms .....	151
I <sup>2</sup> C Master Mode .....	169
I <sup>2</sup> C Mode .....	148
I <sup>2</sup> C Mode Operation .....	150
I <sup>2</sup> C Slave Mode Operation .....	153
Module Overview .....	147
Multi-Phase System .....	22

## O

OPCODE Field Descriptions .....	193
Oscillator .....	83
Associated Registers .....	84
Calibration .....	83
Delay Upon Power-up .....	84
Frequency Tuning .....	83
Internal Oscillator .....	83
Oscillator Module .....	84
Output .....	49
Multiple System .....	22
Overcurrent .....	20, 38, 39
Overvoltage .....	20, 25, 48
Overvoltage Enable .....	51
Power Good .....	22
Type .....	12
Undervoltage .....	20, 25, 48
Undervoltage Accelerator .....	49
Undervoltage Enable .....	51
Voltage .....	18
Soft-Start .....	22
Tracking .....	22
Voltage Configuration .....	47
Voltage Sense Pull-up/Pull-down .....	49
Overcurrent .....	39
Overvoltage Accelerator .....	49

## P

Packaging .....	207
Marking .....	207
Specifications .....	208
PCL .....	78
Modifying .....	78
PCLATH .....	78
PCON Register .....	87, 92
Pin Diagram	
24-Pin QFN .....	2
28-Pin QFN .....	4
Pinout Description	
Summary .....	3, 5
Pinout Description Table .....	12
PIR1 Register .....	98
PIR2 Register .....	99
PMADRH Register .....	105
PMADRL Register .....	105, 106
PMCON1 Register .....	105, 107
PMCON2 Register .....	105
PMDATH Register .....	106
PMDATL Register .....	106
PMDRH Register .....	107
PORTB	
Additional Pin Functions	
Weak Pull-up .....	117
Pin Descriptions and Diagrams .....	119
PORTGPA .....	112, 121
ANSELA Register .....	113
Associated Registers .....	115
Functions and Output Priorities .....	113
Interrupt-on-Change .....	112
Weak Pull-Ups .....	112
PORTGPA Register .....	112
PORTGPB .....	116, 121
ANSELB Register .....	116
Associated Registers .....	119
Functions and Output Priorities .....	116
Interrupt-on-Change .....	116
P1B/P1C/P1D.Capture/Compare/PWM .....	116
Weak Pull-Ups .....	116
PORTGPB Register .....	116, 117
Power-Down Mode (Sleep) .....	101
Associated Registers .....	102
Power-on Reset (POR) .....	86
Power-up Timer (PWRT) .....	87
Prescaler, Timer1	
Select (T1CKPS1:T1CKPS0 Bits) .....	46
Product Identification System .....	223
Program Memory .....	69
Map and Stack (MCP19111) .....	69
Program Memory Protection .....	82
Programming, Device Instructions .....	193
Pulse-Width Modulation .....	33
Associated Registers .....	145
Duty Cycle .....	145
Module .....	143
Operating during Sleep .....	145
Period .....	144
Stand-alone Mode .....	143
Standard Mode .....	143
Switching Frequency Synchronization Mode .....	143

# MCP19110/11

## R

Reader Response .....	222
Read-Modify-Write Operations.....	193
Register	
OVFCON (Output Voltage Set Point Fine Control) .....	47
Registers	
ABECON (Analog Block Enable Control).....	52
ADCON0 (ADC Control 0) .....	129
ADCON1 (ADC Control 1) .....	130
ADRESH (ADC Result High) with ADFM = 0).....	130
ADRESL (ADC Result Low) with ADFM = 0).....	130
ANSELA (Analog Select GPA).....	115
ANSELB (Analog Select GPB).....	118
APFCON (Alternate Pin Function Control).....	112
ATSTCON (Analog Bench Test Control) .....	57
BUFFCON (Unity Gain Buffer Control) .....	58
CALWD1 (Calibration Word 1).....	59
CALWD2 (Calibration Word 2).....	60
CALWD3 (Calibration Word 3).....	61
CALWD4 (Calibration Word 4).....	62
CALWD5 (Calibration Word 5).....	63
CALWD6 (Calibration Word 6).....	64
CALWD7 (Calibration Word 7).....	65
CMPZCON (Compensation Setting Control) .....	43
CONFIG (Configuration Word).....	81
CSDGCON (Voltage For Zero Current Control).....	41
CSGSCON (Current Sense AC Gain Control) .....	40
DEADCON (Driver Dead Time Control).....	46
DEVICEID (Device ID) .....	82
INTCON (Interrupt Control).....	95
IOCA (Interrupt-on-Change PORTGPA).....	122
IOCB (Interrupt-on-Change PORTGPB).....	122
LPCRCON (Slope Compensation Ramp Control).....	44
OCCON (Output Overcurrent Control).....	39
OOVCON (Output Overvoltage Detect Level Control).....	48
OPTION_REG (Option) .....	77
OSCTUNE (Oscillator Tuning).....	83
OUVCON (Output Undervoltage Detect Level Control) ..	48
OVCCON (Output Voltage Set Point Coarse Control).....	47
PCON (Power Control) .....	87, 92
PE1(Analog Peripheral Enable 1 Control) .....	50
PIE1 (Peripheral Interrupt Enable).....	96
PIR1 (Peripheral Interrupt Flag).....	98
PIR2 (Peripheral Interrupt Flag).....	99
PMADRL (Program Memory Address).....	106
PMCON1 (Program Memory Control).....	107
PMDATH (Program Memory Data) .....	106
PMDATL (Program Memory Data).....	106
PMDRH (Program Memory Address).....	107
PORTGPA .....	113
PORTGPB .....	117
RELEFF (Relative Efficiency Measurement) .....	67
Reset Values.....	89
SLVGNCON (MASTER Error Signal Input Gain Control)	
45	
Special Registers Summary.....	73, 74, 75, 76
SSPCON1(SSP Control).....	185
SSPSTAT (SSP Status).....	184
SSPxADD (MSSPx Address and Baud Rate, I <sup>2</sup> C Mode)	
188, 189	
SSPxCON1 (MSSPx Control 1).....	185
SSPxCON2 (SSPx Control 2) .....	186
SSPxCON3 (SSPx Control 3).....	187
SSPxMSK (SSPx Mask) .....	188, 189

SSPxSTAT (SSPx Status).....	184
STATUS .....	71
T1CON (Timer1 Control) .....	138
TRISA (Tri-State PORTA).....	114
TRISGPB (PORTGPB Tri-State) .....	117
TXCON .....	141
VINLVL (Input Undervoltage Lockout Control) .....	37
VZCCON (Voltage for Zero Current Control).....	42
WPUB (Weak Pull-up PORTB).....	114
WPUGPA	
Weak Pull-up PORTGPA.....	114
WPUGPB (Weak Pull-up PORTGPB) .....	118
Relative Efficiency Circuitry Control.....	51
Relative Efficiency Measurement .....	67
Procedure .....	67
Relative Efficiency Measurement Control.....	51
Reset .....	85
Determining Causes .....	91
Resets.....	85
Associated Registers .....	92
Revision History.....	213

## S

Signal Chain Control.....	51
Sleep	
Wake-up from .....	101
Wake-up Using Interrupts.....	102
Slope Compensation .....	18, 44
Slope Compensation Control.....	51
Software Simulator (MPLAB SIM) .....	205
Special Event Trigger .....	128
Special Function Registers .....	71
Special Registers Summary	
Bank 0 .....	73
Bank 1 .....	74
Bank 2 .....	75
Bank 3 .....	76
SSPxADD Register.....	188, 189
SSPxCON1 Register .....	185
SSPxCON2 Register .....	186
SSPxCON3 Register .....	187
SSPxMSK Register.....	188, 189
SSPxOV.....	174
SSPxOV Status Flag .....	174
SSPxSTAT Register .....	184
R/W Bit .....	153
Stack.....	78
Start-up Sequence.....	87
STATUS Register .....	71
Switching Frequency .....	18
System Bench Testing.....	22, 57

<b>T</b>	
T1CON Register .....	138
T1CKPS1:T1CKPS0 Bits .....	46
Temperature Indicator Module .....	123
Thermal Specifications .....	28
Timer Requirements	
RESET, Watchdog Timer, Oscillator Start-up Timer and Power-up .....	32
Timer0 .....	135, 141
8-Bit Counter Mode .....	135
8-bit Timer Mode .....	135
Associated Registers .....	136
External Clock .....	136
Operation .....	135
Operation During Sleep .....	136
T0CKI .....	136
Timer0 Module .....	135
Timer1 .....	137
Associated Registers .....	139
Associated registers .....	139
Clock Source Selection .....	137
Control Register .....	138
Interrupt .....	138
Operation .....	137
Operation During Sleep .....	138
Prescaler .....	138
Sleep .....	138
TMR1H Register .....	137
TMR1L Register .....	137
Timer1 Module .....	137
Timer2	
Associated registers .....	141
Control Register .....	141
Operation .....	140
Timer2 Module .....	140
Timer2/4/6	
Associated Registers .....	141
Timers	
Timer1	
T1CON .....	138
Timer2/4/6	
TXCON .....	141
Timing Diagrams	
Acknowledge Sequence .....	176
Baud Rate Generator with Clock Arbitration .....	170
BRG Reset Due to SDA Arbitration During Start Condition .....	179
Bus Collision During a Repeated Start Condition (Case 1) .....	180
Bus Collision During a Repeated Start Condition (Case 2) .....	180
Bus Collision During a Start Condition (SCL = 0) .....	179
Bus Collision During a Stop Condition (Case 1) .....	181
Bus Collision During a Stop Condition (Case 2) .....	181
Bus Collision During Start Condition (SDA only) .....	178
Bus Collision for Transmit and Acknowledge .....	177
Capture/Compare/PWM .....	33
Clock Synchronization .....	167
First Start Bit Timing .....	170
I <sup>2</sup> C Master Mode (7 or 10-Bit Transmission) .....	173
I <sup>2</sup> C Master Mode (7-Bit Reception) .....	175
I <sup>2</sup> C Stop Condition Receive or Transmit Mode .....	176
INT Pin Interrupt .....	94
Power-up Timer .....	31
Repeat Start Condition .....	171
Reset .....	31
Start-up Timer .....	31
Time-out Sequence	
Case 1 .....	87
Case 2 .....	88
Case 3 .....	88
Timer0 .....	32
Timer1 .....	32
Wake-up from Interrupt .....	102
Watchdog Timer .....	31
Timing Parameter Symbology .....	29
Timing Requirements	
CLKOUT and I/O .....	31
External Clock .....	30
TRISA Register .....	114
TRISGPA .....	112
TRISGPA Register .....	112
TRISGPB Register .....	116, 117
TXCON (Timer2/4/6) Register .....	141
Typical Application Circuit .....	9
Typical Performance Curves .....	53
<b>U</b>	
Undervoltage Lockout	
Input .....	37
Unity Gain Buffer .....	58
<b>V</b>	
Voltage For Zero Current .....	42
<b>W</b>	
Watchdog Timer (WDT) .....	87, 103
Associated Registers .....	104
Configuration Word w/ Watchdog Timer .....	104
Operation .....	103
Period .....	103
Programming Considerations .....	103
WCOL .....	170, 172, 174, 176
WCOL Status Flag .....	170, 172, 174, 176
WPUB Register .....	114
WPUGPB Register .....	118
WWW Address .....	221
WWW, On-Line Support .....	7

# MCP19110/11

---

NOTES:

## THE MICROCHIP WEB SITE

Microchip provides online support via our website at [www.microchip.com](http://www.microchip.com). This web site is used as a means to make files and information easily available to customers. Accessible by using your favorite Internet browser, the web site contains the following information:

- **Product Support** – Data sheets and errata, application notes and sample programs, design resources, user's guides and hardware support documents, latest software releases and archived software
- **General Technical Support** – Frequently Asked Questions (FAQ), technical support requests, online discussion groups, Microchip consultant program member listing
- **Business of Microchip** – Product selector and ordering guides, latest Microchip press releases, listing of seminars and events, listings of Microchip sales offices, distributors and factory representatives

## CUSTOMER CHANGE NOTIFICATION SERVICE

Microchip's customer notification service helps keep customers current on Microchip products. Subscribers will receive e-mail notification whenever there are changes, updates, revisions or errata related to a specified product family or development tool of interest.

To register, access the Microchip web site at [www.microchip.com](http://www.microchip.com). Under "Support", click on "Customer Change Notification" and follow the registration instructions.

## CUSTOMER SUPPORT

Users of Microchip products can receive assistance through several channels:

- Distributor or Representative
- Local Sales Office
- Field Application Engineer (FAE)
- Technical Support
- Development Systems Information Line

Customers should contact their distributor, representative or field application engineer (FAE) for support. Local sales offices are also available to help customers. A listing of sales offices and locations is included in the back of this document.

**Technical support is available through the web site at: <http://microchip.com/support>**

# MCP19110/11

---

NOTES:

## PRODUCT IDENTIFICATION SYSTEM

To order or obtain information, e.g., on pricing or delivery, refer to the factory or the listed sales office.

PART NO.	[X] <sup>(1)</sup>	-	X	/XX	
Device	Tape and Reel Option		Temperature Range	Package	
<b>Device:</b> MCP19110: Digitally Enhanced Power Analog Controller with Integrated Synchronous Driver MCP19111: Digitally Enhanced Power Analog Controller with Integrated Synchronous Driver	<b>Tape and Reel Option:</b> Blank = Standard packaging (tube) T = Tape and Reel		<b>Temperature Range:</b> E = -40°C to +125°C (Extended)	<b>Package:</b> MJ = 24-lead Plastic Quad Flat, No Lead Package - 4x4x0.9 mm body (QFN) MQ = 28-lead Plastic Quad Flat, No Lead Package - 5x5x0.9 mm body (QFN)	<b>Examples:</b> a) MCP19110-E/MJ: Extended temperature, 24LD QFN 4x4 package b) MCP19110T-E/MJ: Tape and Reel, Extended temperature, 24LD QFN 4x4 package a) MCP19111-E/MQ: Extended temperature, 28LD QFN 5x5 package b) MCP19111T-E/MQ: Tape and Reel, Extended temperature, 28LD QFN 5x5 package  <b>Note 1:</b> Tape and Reel identifier only appears in the catalog part number description. This identifier is used for ordering purposes and is not printed on the device package. Check with your Microchip Sales Office for package availability with the Tape and Reel option.

## NOTICE TO CUSTOMERS

This product is subject to a license from Power-One<sup>®</sup>, Inc. related to digital power technology (DPT) patents owned by Power-One, Inc. This license does not extend to stand-alone power supply products.



---

**Note the following details of the code protection feature on Microchip devices:**

- Microchip products meet the specification contained in their particular Microchip Data Sheet.
- Microchip believes that its family of products is one of the most secure families of its kind on the market today, when used in the intended manner and under normal conditions.
- There are dishonest and possibly illegal methods used to breach the code protection feature. All of these methods, to our knowledge, require using the Microchip products in a manner outside the operating specifications contained in Microchip's Data Sheets. Most likely, the person doing so is engaged in theft of intellectual property.
- Microchip is willing to work with the customer who is concerned about the integrity of their code.
- Neither Microchip nor any other semiconductor manufacturer can guarantee the security of their code. Code protection does not mean that we are guaranteeing the product as “unbreakable.”

Code protection is constantly evolving. We at Microchip are committed to continuously improving the code protection features of our products. Attempts to break Microchip's code protection feature may be a violation of the Digital Millennium Copyright Act. If such acts allow unauthorized access to your software or other copyrighted work, you may have a right to sue for relief under that Act.

---

Information contained in this publication regarding device applications and the like is provided only for your convenience and may be superseded by updates. It is your responsibility to ensure that your application meets with your specifications. MICROCHIP MAKES NO REPRESENTATIONS OR WARRANTIES OF ANY KIND WHETHER EXPRESS OR IMPLIED, WRITTEN OR ORAL, STATUTORY OR OTHERWISE, RELATED TO THE INFORMATION, INCLUDING BUT NOT LIMITED TO ITS CONDITION, QUALITY, PERFORMANCE, MERCHANTABILITY OR FITNESS FOR PURPOSE. Microchip disclaims all liability arising from this information and its use. Use of Microchip devices in life support and/or safety applications is entirely at the buyer's risk, and the buyer agrees to defend, indemnify and hold harmless Microchip from any and all damages, claims, suits, or expenses resulting from such use. No licenses are conveyed, implicitly or otherwise, under any Microchip intellectual property rights.

#### **Trademarks**

The Microchip name and logo, the Microchip logo, dsPIC, FlashFlex, KEELOQ, KEELOQ logo, MPLAB, PIC, PICmicro, PICSTART, PIC<sup>32</sup> logo, rPIC, SST, SST Logo, SuperFlash and UNI/O are registered trademarks of Microchip Technology Incorporated in the U.S.A. and other countries.

FilterLab, Hampshire, HI-TECH C, Linear Active Thermistor, MTP, SEEVAL and The Embedded Control Solutions Company are registered trademarks of Microchip Technology Incorporated in the U.S.A.

Silicon Storage Technology is a registered trademark of Microchip Technology Inc. in other countries.

Analog-for-the-Digital Age, Application Maestro, BodyCom, chipKIT, chipKIT logo, CodeGuard, dsPICDEM, dsPICDEM.net, dsPICworks, dsSPEAK, ECAN, ECONOMONITOR, FanSense, HI-TIDE, In-Circuit Serial Programming, ICSP, Mindi, MiWi, MPASM, MPF, MPLAB Certified logo, MPLIB, MPLINK, mTouch, Omniclient Code Generation, PICC, PICC-18, PICDEM, PICDEM.net, PICkit, PICtail, REAL ICE, rLAB, Select Mode, SQI, Serial Quad I/O, Total Endurance, TSHARC, UniWinDriver, WiperLock, ZENA and Z-Scale are trademarks of Microchip Technology Incorporated in the U.S.A. and other countries.

SQTP is a service mark of Microchip Technology Incorporated in the U.S.A.

GestIC and ULPP are registered trademarks of Microchip Technology Germany II GmbH & Co. KG, a subsidiary of Microchip Technology Inc., in other countries.

All other trademarks mentioned herein are property of their respective companies.

© 2013, Microchip Technology Incorporated, Printed in the U.S.A., All Rights Reserved.

 Printed on recycled paper.

ISBN: 978-1-62077-288-1

**QUALITY MANAGEMENT SYSTEM**  
**CERTIFIED BY DNV**  
**== ISO/TS 16949 ==**

*Microchip received ISO/TS-16949:2009 certification for its worldwide headquarters, design and wafer fabrication facilities in Chandler and Tempe, Arizona; Gresham, Oregon and design centers in California and India. The Company's quality system processes and procedures are for its PIC<sup>®</sup> MCUs and dsPIC<sup>®</sup> DSCs, KEELOQ<sup>®</sup> code hopping devices, Serial EEPROMs, microperipherals, nonvolatile memory and analog products. In addition, Microchip's quality system for the design and manufacture of development systems is ISO 9001:2000 certified.*



# MICROCHIP

## Worldwide Sales and Service

### AMERICAS

**Corporate Office**  
2355 West Chandler Blvd.  
Chandler, AZ 85224-6199  
Tel: 480-792-7200  
Fax: 480-792-7277  
Technical Support:  
<http://www.microchip.com/support>  
Web Address:  
[www.microchip.com](http://www.microchip.com)

**Atlanta**  
Duluth, GA  
Tel: 678-957-9614  
Fax: 678-957-1455

**Boston**  
Westborough, MA  
Tel: 774-760-0087  
Fax: 774-760-0088

**Chicago**  
Itasca, IL  
Tel: 630-285-0071  
Fax: 630-285-0075

**Cleveland**  
Independence, OH  
Tel: 216-447-0464  
Fax: 216-447-0643

**Dallas**  
Addison, TX  
Tel: 972-818-7423  
Fax: 972-818-2924

**Detroit**  
Farmington Hills, MI  
Tel: 248-538-2250  
Fax: 248-538-2260

**Indianapolis**  
Noblesville, IN  
Tel: 317-773-8323  
Fax: 317-773-5453

**Los Angeles**  
Mission Viejo, CA  
Tel: 949-462-9523  
Fax: 949-462-9608

**Santa Clara**  
Santa Clara, CA  
Tel: 408-961-6444  
Fax: 408-961-6445

**Toronto**  
Mississauga, Ontario,  
Canada  
Tel: 905-673-0699  
Fax: 905-673-6509

### ASIA/PACIFIC

**Asia Pacific Office**  
Suites 3707-14, 37th Floor  
Tower 6, The Gateway  
Harbour City, Kowloon  
Hong Kong  
Tel: 852-2401-1200  
Fax: 852-2401-3431

**Australia - Sydney**  
Tel: 61-2-9868-6733  
Fax: 61-2-9868-6755

**China - Beijing**  
Tel: 86-10-8569-7000  
Fax: 86-10-8528-2104

**China - Chengdu**  
Tel: 86-28-8665-5511  
Fax: 86-28-8665-7889

**China - Chongqing**  
Tel: 86-23-8980-9588  
Fax: 86-23-8980-9500

**China - Hangzhou**  
Tel: 86-571-2819-3187  
Fax: 86-571-2819-3189

**China - Hong Kong SAR**  
Tel: 852-2943-5100  
Fax: 852-2401-3431

**China - Nanjing**  
Tel: 86-25-8473-2460  
Fax: 86-25-8473-2470

**China - Qingdao**  
Tel: 86-532-8502-7355  
Fax: 86-532-8502-7205

**China - Shanghai**  
Tel: 86-21-5407-5533  
Fax: 86-21-5407-5066

**China - Shenyang**  
Tel: 86-24-2334-2829  
Fax: 86-24-2334-2393

**China - Shenzhen**  
Tel: 86-755-8864-2200  
Fax: 86-755-8203-1760

**China - Wuhan**  
Tel: 86-27-5980-5300  
Fax: 86-27-5980-5118

**China - Xian**  
Tel: 86-29-8833-7252  
Fax: 86-29-8833-7256

**China - Xiamen**  
Tel: 86-592-2388138  
Fax: 86-592-2388130

**China - Zhuhai**  
Tel: 86-756-3210040  
Fax: 86-756-3210049

### ASIA/PACIFIC

**India - Bangalore**  
Tel: 91-80-3090-4444  
Fax: 91-80-3090-4123

**India - New Delhi**  
Tel: 91-11-4160-8631  
Fax: 91-11-4160-8632

**India - Pune**  
Tel: 91-20-2566-1512  
Fax: 91-20-2566-1513

**Japan - Osaka**  
Tel: 81-6-6152-7160  
Fax: 81-6-6152-9310

**Japan - Tokyo**  
Tel: 81-3-6880-3770  
Fax: 81-3-6880-3771

**Korea - Daegu**  
Tel: 82-53-744-4301  
Fax: 82-53-744-4302

**Korea - Seoul**  
Tel: 82-2-554-7200  
Fax: 82-2-558-5932 or  
82-2-558-5934

**Malaysia - Kuala Lumpur**  
Tel: 60-3-6201-9857  
Fax: 60-3-6201-9859

**Malaysia - Penang**  
Tel: 60-4-227-8870  
Fax: 60-4-227-4068

**Philippines - Manila**  
Tel: 63-2-634-9065  
Fax: 63-2-634-9069

**Singapore**  
Tel: 65-6334-8870  
Fax: 65-6334-8850

**Taiwan - Hsin Chu**  
Tel: 886-3-5778-366  
Fax: 886-3-5770-955

**Taiwan - Kaohsiung**  
Tel: 886-7-213-7828  
Fax: 886-7-330-9305

**Taiwan - Taipei**  
Tel: 886-2-2508-8600  
Fax: 886-2-2508-0102

**Thailand - Bangkok**  
Tel: 66-2-694-1351  
Fax: 66-2-694-1350

### EUROPE

**Austria - Wels**  
Tel: 43-7242-2244-39  
Fax: 43-7242-2244-393

**Denmark - Copenhagen**  
Tel: 45-4450-2828  
Fax: 45-4485-2829

**France - Paris**  
Tel: 33-1-69-53-63-20  
Fax: 33-1-69-30-90-79

**Germany - Munich**  
Tel: 49-89-627-144-0  
Fax: 49-89-627-144-44

**Italy - Milan**  
Tel: 39-0331-742611  
Fax: 39-0331-466781

**Netherlands - Drunen**  
Tel: 31-416-690399  
Fax: 31-416-690340

**Spain - Madrid**  
Tel: 34-91-708-08-90  
Fax: 34-91-708-08-91

**UK - Wokingham**  
Tel: 44-118-921-5869  
Fax: 44-118-921-5820

11/29/12

Компания «Life Electronics» занимается поставками электронных компонентов импортного и отечественного производства от производителей и со складов крупных дистрибьюторов Европы, Америки и Азии.

С конца 2013 года компания активно расширяет линейку поставок компонентов по направлению коаксиальный кабель, кварцевые генераторы и конденсаторы (керамические, пленочные, электролитические), за счёт заключения дистрибьюторских договоров

Мы предлагаем:

- Конкурентоспособные цены и скидки постоянным клиентам.
- Специальные условия для постоянных клиентов.
- Подбор аналогов.
- Поставку компонентов в любых объемах, удовлетворяющих вашим потребностям.
- Приемлемые сроки поставки, возможна ускоренная поставка.
- Доставку товара в любую точку России и стран СНГ.
- Комплексную поставку.
- Работу по проектам и поставку образцов.
- Формирование склада под заказчика.
- Сертификаты соответствия на поставляемую продукцию (по желанию клиента).
- Тестирование поставляемой продукции.
- Поставку компонентов, требующих военную и космическую приемку.
- Входной контроль качества.
- Наличие сертификата ISO.

В составе нашей компании организован Конструкторский отдел, призванный помогать разработчикам, и инженерам.

Конструкторский отдел помогает осуществить:

- Регистрацию проекта у производителя компонентов.
- Техническую поддержку проекта.
- Защиту от снятия компонента с производства.
- Оценку стоимости проекта по компонентам.
- Изготовление тестовой платы монтаж и пусконаладочные работы.



Тел: +7 (812) 336 43 04 (многоканальный)  
Email: [org@lifeelectronics.ru](mailto:org@lifeelectronics.ru)