

Single-Stage Buck Current Control LED Driver with High Voltage MOSFET Integrated

DESCRIPTION

The TS19751 is a high performance LED driver which accuracy constant current PWM controller with high voltage power MOSFET integrated. It achieves high accuracy by peak current mode. The device provide high efficiency along with a number of key built-in protection features while minimizing the external component count, simplifying EMI design and lowering the total bill of material cost. TS19751 also achieving excellent line and load regulation. Pulse-by-pulse waveform analysis allows for a loop response that is much faster than traditional solutions, resulting in improved dynamic load response. The built-in current limit function enables optimized transformer design in universal off-line applications over a wide input voltage range.

FEATURES

- Competitive bill of material design
- Built-in Power MOSFET
- Constant current accuracy $\leq \pm 3\%$
- V_{CC} Over Voltage Clamp 19V
- Peak Current Mode Control
- LED Open Protection(OLP)
- Over Current Protection (OCP)
- Internal Over Thermal Protection (OTP)
- Fast start-up time $< 500\text{ms}$

APPLICATION

- Candle light bulb
- GU10 light bulb



- Pin Definition:**
1. GND
 2. V_{CC}
 3. CS
 4. CS
 5. DRAIN
 6. DRAIN
 7. HV
 8. GND

Notes: MSL 3 (Moisture Sensitivity Level) per J-STD-020

TYPICAL APPLICATION CIRCUIT

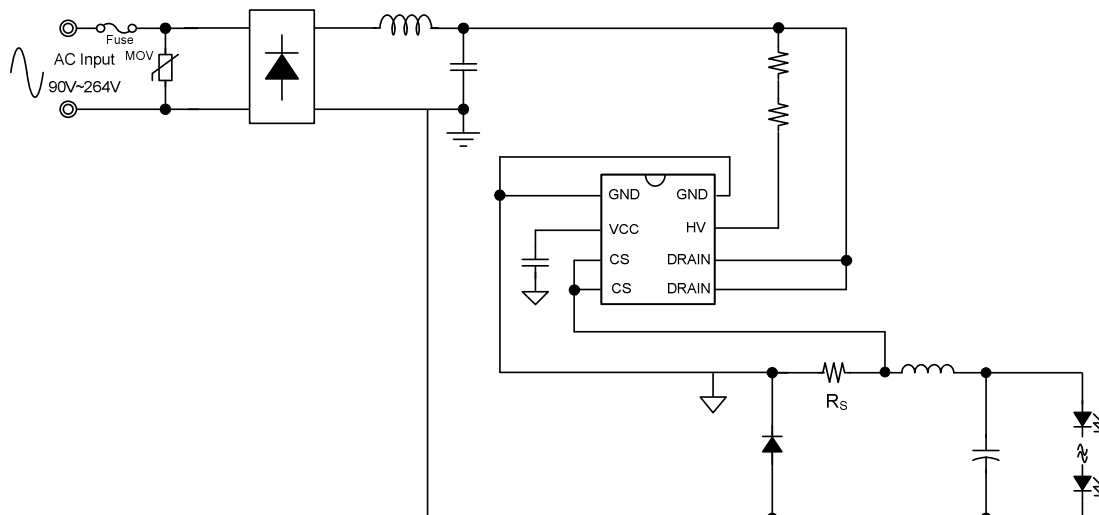

ABSOLUTE MAXIMUM RATINGS ($T_A = 25^\circ\text{C}$ unless otherwise specified) ^(Note 1)			
PARAMETER	SYMBOL	LIMIT	UNIT
Power Supply Pin	V_{CC}	40	V
CS Voltage to GND	V_{CS}	-0.3 to 5.5	V
HV Voltage to GND	V_{HV}	-0.3 to 500	V
Operating Temperature Range	T_{OPR}	-40 to +105	$^\circ\text{C}$
Junction Temperature Range	T_J	-40 to +150	$^\circ\text{C}$
Storage Temperature Range	T_{STG}	-65 to +150	$^\circ\text{C}$
Lead Temperature (Soldering 10 sec)	T_{LEAD}	260	$^\circ\text{C}$
Power Dissipation @ $T_A=25^\circ\text{C}$	P_D	0.6	W
ESD Rating (Human Body Mode) ^(Note 2)	HBM	2	kV
ESD Rating (Machine Mode) ^(Note 2)	MM	200	V

THERMAL PERFORMANCE ^(Note 3)			
PARAMETER	SYMBOL	LIMIT	UNIT
Thermal Resistance - Junction to Case	$R_{\theta JC}$	50	$^\circ\text{C/W}$
Thermal Resistance - Junction to Ambient	$R_{\theta JA}$	208	$^\circ\text{C/W}$

RECOMMENDED OPERATING CONDITION ($T_A = 25^\circ\text{C}$ unless otherwise specified) ^(Note 4)			
PARAMETER	SYMBOL	LIMIT	UNIT
Power Supply Pin	V_{CC}	19	V
CS Voltage to GND	V_{CS}	-0.3 to 5	V
HV Voltage to GND	V_{HV}	-0.3 to 500	V
Operating Junction Temperature Range	T_J	-40 to +150	$^\circ\text{C}$
Operating Ambient Temperature Range	T_{OPA}	-40 to +85	$^\circ\text{C}$

ELECTRICAL SPECIFICATIONS ($T_A = 25^\circ\text{C}$ unless otherwise specified)						
PARAMETER	SYMBOL	CONDITION	MIN	TYP	MAX	UNIT
Supply Voltage						
Start-up Current	$V_{CC(ST)}$	$V_{CC} = V_{UVLO(on)} - 1V$	--	45	--	μA
Operating Current	I_{OPA}	With 1nF load on out pin	--	2	--	mA
UVLO(off)	$V_{UVLO(off)}$		7	8	9	V
UVLO(on)	$V_{UVLO(on)}$		16	17.5	19	V
VCC Clamp Voltage	V_{VCC}		17	19	21	V
Voltage Feedback						
Feedback Reference Voltage	V_{FB}		0.194	0.2	0.206	V
Current Sensing						
CS Limit Voltage	V_{OCP}		--	0.5	--	V
Leading-Edge Blanking Time	LEB_t		--	400	--	ns
Delay to Output			--	100	--	ns
Switching Frequency						
Start Frequency	f_{STR}		3	4.5	6	kHz

ELECTRICAL SPECIFICATIONS ($T_A = 25^\circ\text{C}$ unless otherwise specified)						
PARAMETER	SYMBOL	CONDITION	MIN	TYP	MAX	UNIT
MOSFET Section						
Drain-Source Breakdown Voltage	BV_{DS}	TS19751ACS	500	--	--	V
		TS19751BCS	650	--	--	V
Drain-Source On-Resistance	$R_{DS(ON)}$	TS19751ACS	--	--	30	Ω
		TS19751BCS	--	--	17	Ω
Thermal Section (Note 5, 6)						
Thermal Shutdown			--	150	--	$^\circ\text{C}$
Thermal Shutdown Release			--	120	--	$^\circ\text{C}$

Note:

- Stresses listed as the above "Absolute Maximum Ratings" may cause permanent damage to the device. These are for stress ratings. Functional operation of the device at these or any other conditions beyond those indicated in the operational sections of the specifications is not implied. Exposure to absolute maximum rating conditions for extended periods may remain possibility to affect device reliability.
- Devices are ESD sensitive. Handling precaution recommended.
- Thermal Resistance is specified with the component mounted on a low effective thermal conductivity test board in free air at $T_A=25^\circ\text{C}$.
- The device is not guaranteed to function outside its operating conditions
- Guaranteed by design.
- Auto Recovery Type.

ORDERING INFORMATION

PART NO.	PACKAGE	PACKING
TS19751ACS RLG	SOP-8	2,500pcs / 13"Reel
TS19751BCS RLG	SOP-8	2,500pcs / 13"Reel

Not Recommended

FUNCTION BLOCK

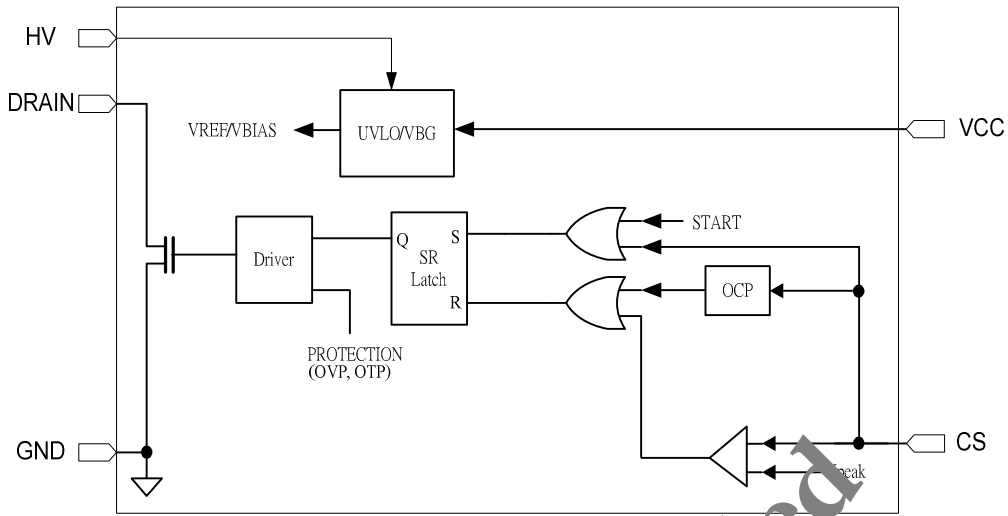

PIN DESCRIPTION

PIN NO.	NAME	FUNCTION
1,8	GND	Ground return for all internal circuitry.
2	VCC	Power supply pin for all internal circuitry.
3,4	CS	Input current sense pin.
5,6	DRAIN	Drain of internal HV MOS.
7	HV	HV start up pin

Not Recommended

APPLICATION INFORMATION

Start-up Current

The typical start-up current is around 45μA. The TS19751 has a built-in HV start-up circuit that avoids the need for a start-up resistor.

Under Voltage Lockout (UVLO)

A hysteresis UVLO comparator is implemented in TS19751. The turn-on and turn-off thresholds level are fixed at 17.5V and 8V respectively. This hysteresis shown in Fig.1 ensures that the start-up capacitor will be adequate to supply the chip during start-up. For quick start-up of the LED driver, the start-up resistor should be matched with the start-up capacitor.

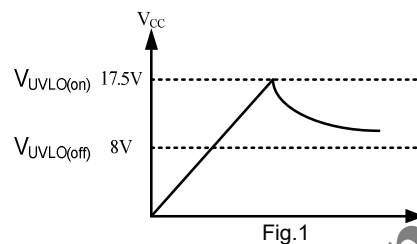

Leading-Edge Blanking (LEB)

Each time the power MOSFET is switched on, a turn-on spike will inevitably occur at the sense resistor. To avoid fault trigger, a 400ns leading-edge blanking time is built in. Conventional RC filtering can therefore be omitted. During this blanking period, the current-limit comparator is disabled and cannot switch off the gate driver.

VCC Over Voltage Clamp

VCC is clamped to 19V by an internal clamping circuit to guarantee IC normal operation.

Over Current Protection (OCP)

The TS19751 has built-in cycle by cycle over current protection function on CS pin. As the CS pin voltage is larger than V_{OCP} (0.5V), the gate output will be turned off immediately to avoid the driver board to be burned out.

Open load Protection (OLP)

To prevent the LED driver from being damaged, the TS19751 has an implemented OLP function. The open load protection will shut the gate driver when minimum off time keep shorter than 4.5μs.

Over Temperature Protection (OTP)

Internal 165°C comparator will trigger temperature protection (OTP). OTP will shut down system, until internal temperature back to 120°C.

PACKAGE OUTLINE DIMENSIONS (Unit: Millimeters)

SOP-8

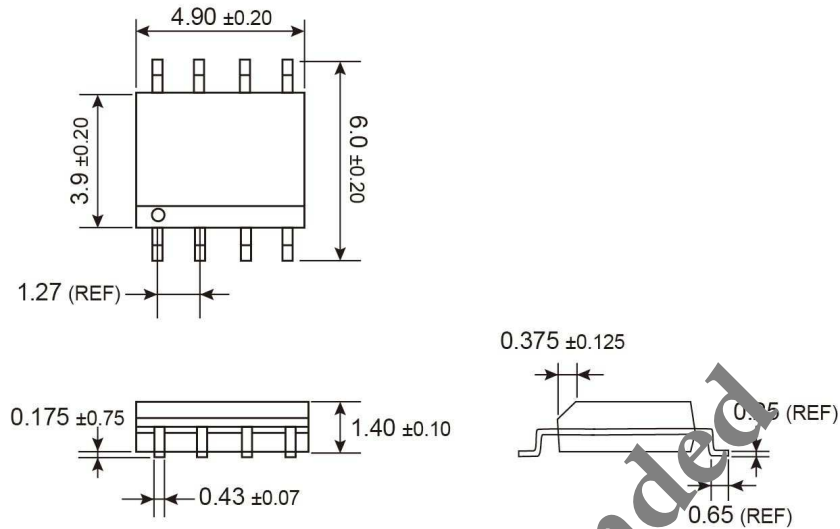

SUGGESTED PAD LAYOUT (Unit: Millimeters)

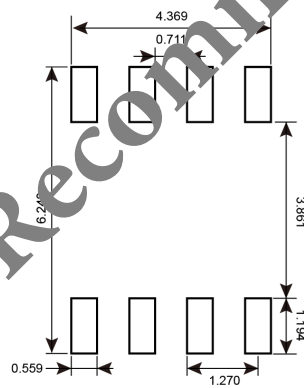

MARKING DIAGRAM

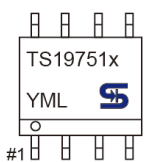

- x** = Device code A/B
- Y** = Year Code
- M** = Month Code for Halogen Free Product
 - O** =Jan **P** =Feb **Q** =Mar **R** =Apr
 - S** =May **T** =Jun **U** =Jul **V** =Aug
 - W** =Sep **X** =Oct **Y** =Nov **Z** =Dec
- L** = Lot Code (1~9, A~Z)

Not Recommended

Notice

Specifications of the products displayed herein are subject to change without notice. TSC or anyone on its behalf, assumes no responsibility or liability for any errors or inaccuracies.

Information contained herein is intended to provide a product description only. No license, express or implied, to any intellectual property rights is granted by this document. Except as provided in TSC's terms and conditions of sale for such products, TSC assumes no liability whatsoever, and disclaims any express or implied warranty, relating to sale and/or use of TSC products including liability or warranties relating to fitness for a particular purpose, merchantability, or infringement of any patent, copyright, or other intellectual property right.

The products shown herein are not designed for use in medical, life-saving, or life-sustaining applications. Customers using or selling these products for use in such applications do so at their own risk and agree to fully indemnify TSC for any damages resulting from such improper use or sale.

Компания «Life Electronics» занимается поставками электронных компонентов импортного и отечественного производства от производителей и со складов крупных дистрибьюторов Европы, Америки и Азии.

С конца 2013 года компания активно расширяет линейку поставок компонентов по направлению коаксиальный кабель, кварцевые генераторы и конденсаторы (керамические, пленочные, электролитические), за счёт заключения дистрибьюторских договоров

Мы предлагаем:

- Конкурентоспособные цены и скидки постоянным клиентам.
- Специальные условия для постоянных клиентов.
- Подбор аналогов.
- Поставку компонентов в любых объемах, удовлетворяющих вашим потребностям.
- Приемлемые сроки поставки, возможна ускоренная поставка.
- Доставку товара в любую точку России и стран СНГ.
- Комплексную поставку.
- Работу по проектам и поставку образцов.
- Формирование склада под заказчика.
- Сертификаты соответствия на поставляемую продукцию (по желанию клиента).
- Тестирование поставляемой продукции.
- Поставку компонентов, требующих военную и космическую приемку.
- Входной контроль качества.
- Наличие сертификата ISO.

В составе нашей компании организован Конструкторский отдел, призванный помогать разработчикам, и инженерам.

Конструкторский отдел помогает осуществить:

- Регистрацию проекта у производителя компонентов.
- Техническую поддержку проекта.
- Защиту от снятия компонента с производства.
- Оценку стоимости проекта по компонентам.
- Изготовление тестовой платы монтаж и пусконаладочные работы.



Тел: +7 (812) 336 43 04 (многоканальный)
Email: org@lifeelectronics.ru