



Features

- RoHS compliant* and halogen free**
- Surface mount SMC package
- Standoff voltage: 5 to 170 volts
- Peak Pulse Power: 5000 watts
- AEC-Q101 compliant***
- UL Recognized

Applications

- Protection of power buses
- Protection of I/O interfaces
- Overvoltage transient protection
- Telecom, computer, industrial and consumer electronics applications

5.0SMDJ-Q Transient Voltage Suppressor Diode Series

General Information

Bourns offers Transient Voltage Suppressor Diodes for surge and ESD protection applications, in compact chip package DO-214AB (SMC) size format. The Transient Voltage Suppressor series offers a choice of Working Peak Reverse Voltage from 5 V up to 170 V and Breakdown Voltage up to 189 V. Typical fast response times are less than 1.0 ps from 0 V to Breakdown Voltage.

Bourns® Chip Diodes conform to JEDEC standards, are easy to handle with standard pick and place equipment and the flat configuration minimizes roll away.

Agency Recognition

Description	
UL	File Number: E153537

Electrical Characteristics (@ T_A = 25 °C Unless Otherwise Noted)

Parameter	Symbol	Value	Unit
Minimum Peak Pulse Power Dissipation (T _p = 1 ms) (Note 1,2)	P _{PK}	5000	Watts
Peak Forward Surge Current 8.3 ms Single Half Sine Wave Superimposed on Rated Load (JEDEC Method) (Note 3,4)	I _{FSM}	300	Amps
Steady State Power Dissipation @ TL = 50 °C	P _{M(AV)}	6.5	Watts
Maximum Instantaneous Forward Voltage @ I _{PP} = 100 A (For Unidirectional Units Only)	V _F	5	Volts
Operating Temperature Range	T _J	-55 to +150	°C
Storage Temperature Range	T _{STG}	-55 to +150	°C

1. Non-repetitive current pulse, per Pulse Waveform graph and derated above T_A = 25 °C per Pulse Derating Curve.
2. Thermal Resistance Junction to Lead.
3. 8.3 ms Single Sine Wave duty cycle = 4 pulses maximum per minute (unidirectional units only).
4. Mounted on 8.0 mm x 8.0 mm copper pad area to each terminal.

BOURNS®

Asia-Pacific:

Tel: +886-2 2562-4117 • Email: asiacus@bourns.com

Europe:

Tel: +36 88 885 877 • Email: eurocus@bourns.com

The Americas:

Tel: +1-951 781-5500 • Email: americus@bourns.com

www.bourns.com

How to Order

	5.0SMDJ 12 CA - Q
Package _____	
5.0SMDJ = SMC/DO-214AB	
Working Peak Reverse Voltage _____	
12 = 12 V _{RWM} (Volts)	
Suffix _____	
A = 5 % Tolerance Unidirectional Device	
CA = 5 % Tolerance Bidirectional Device	
AEC-Q101 Compliant Suffix _____	
Q = AEC-Q101 Compliant, 3000 pcs. per 13-inch Reel	
QH = AEC-Q101 Compliant, 500 pcs. per 7-inch Reel, 3 Reels per Box	



WARNING Cancer and Reproductive Harm - www.P65Warnings.ca.gov

* RoHS Directive 2015/863, Mar 31, 2015 and Annex.

** Bourns considers a product to be "halogen free" if (a) the Bromine (Br) content is 900 ppm or less; (b) the Chlorine (Cl) content is 900 ppm or less; and (c) the total Bromine (Br) and Chlorine (Cl) content is 1500 ppm or less.

*** Q suffix for automotive and other applications requiring appropriate AEC-Q101 compliance for electronic limiters.

Specifications are subject to change without notice.

Users should verify actual device performance in their specific applications.

The products described herein and this document are subject to specific legal disclaimers as set forth on the last page of this document, and at www.bourns.com/docs/legal/disclaimer.pdf.

5.0SMDJ-Q Transient Voltage Suppressor Diode Series

Electrical Characteristics (@ T_A = 25 °C Unless Otherwise Noted)

Unidirectional Device		Bidirectional Device		Breakdown Voltage V _{BR} (Volts)			Reverse Standoff Voltage	Maximum Reverse Leakage @ V _{RWM}	Maximum Clamping Voltage @ I _{PP}	Peak Pulse Current
Part Number	Part Marking	Part Number	Part Marking	Min.	Max.	@ I _T (mA)	V _{RWM} (V)	I _R (μA)	V _C (V)	I _{PP} (A)
5.0SMDJ5.0A-Q	5RDEQ	5.0SMDJ5.0CA-Q	5DDEQ	6.40	7.00	10	5.0	1050	9.2	543.6
5.0SMDJ6.0A-Q	5RDGQ	5.0SMDJ6.0CA-Q	5DDGQ	6.67	7.37	10	6.0	1050	10.3	485.5
5.0SMDJ6.5A-Q	5RDKQ	5.0SMDJ6.5CA-Q	5DDKQ	7.22	7.98	10	6.5	750	11.2	446.5
5.0SMDJ7.0A-Q	5PDMQ	5.0SMDJ7.0CA-Q	5DDMQ	7.78	8.60	10	7.0	300	12.0	416.8
5.0SMDJ7.5A-Q	5PDPQ	5.0SMDJ7.5CA-Q	5DDPQ	8.33	9.21	1	7.5	150	12.9	387.7
5.0SMDJ8.0A-Q	5PDRQ	5.0SMDJ8.0CA-Q	5DDRQ	8.89	9.83	1	8.0	70	13.6	367.7
5.0SMDJ8.5A-Q	5PDTQ	5.0SMDJ8.5CA-Q	5DDTQ	9.44	10.40	1	8.5	30	14.4	347.3
5.0SMDJ9.0A-Q	5PDVQ	5.0SMDJ9.0CA-Q	5DDVQ	10.00	11.10	1	9.0	12	15.4	324.8
5.0SMDJ10A-Q	5PDXQ	5.0SMDJ10CA-Q	5DDXQ	11.10	12.30	1	10.0	6	17.0	294.2
5.0SMDJ11A-Q	5PDZQ	5.0SMDJ11CA-Q	5DDZQ	12.20	13.50	1	11.0	2	18.2	274.8
5.0SMDJ12A-Q	5PEPQ	5.0SMDJ12CA-Q	5BEPQ	13.30	14.70	1	12.0	2	19.9	252.0
5.0SMDJ13A-Q	5PEQQ	5.0SMDJ13CA-Q	5BEQQ	14.40	15.90	1	13.0	2	21.5	233.0
5.0SMDJ14A-Q	5PERQ	5.0SMDJ14CA-Q	5BERQ	15.60	17.20	1	14.0	2	23.2	216.0
5.0SMDJ15A-Q	5PESQ	5.0SMDJ15CA-Q	5BESQ	16.70	18.50	1	15.0	2	24.4	205.0
5.0SMDJ16A-Q	5PETQ	5.0SMDJ16CA-Q	5BETQ	17.80	19.70	1	16.0	2	26.0	193.0
5.0SMDJ17A-Q	5PEUQ	5.0SMDJ17CA-Q	5BEUQ	18.90	20.90	1	17.0	2	27.6	181.0
5.0SMDJ18A-Q	5PEVQ	5.0SMDJ18CA-Q	5BEVQ	20.00	22.10	1	18.0	2	29.2	172.0
5.0SMDJ20A-Q	5PEWQ	5.0SMDJ20CA-Q	5BEWQ	22.20	24.50	1	20.0	2	32.4	155.0
5.0SMDJ22A-Q	5PEXQ	5.0SMDJ22CA-Q	5BEXQ	24.40	26.90	1	22.0	2	35.5	141.0
5.0SMDJ24A-Q	5PEZQ	5.0SMDJ24CA-Q	5BEZQ	26.70	29.50	1	24.0	2	38.9	129.0
5.0SMDJ26A-Q	5PFEQ	5.0SMDJ26CA-Q	5BFEQ	28.90	31.90	1	26.0	2	42.1	119.0
5.0SMDJ28A-Q	5PFGQ	5.0SMDJ28CA-Q	5BFGQ	31.10	34.40	1	28.0	2	45.4	110.0
5.0SMDJ30A-Q	5PFKQ	5.0SMDJ30CA-Q	5BFKQ	33.30	36.80	1	30.0	2	48.4	103.0
5.0SMDJ33A-Q	5PFMQ	5.0SMDJ33CA-Q	5BFMQ	36.70	40.60	1	33.0	2	53.3	93.9
5.0SMDJ36A-Q	5PFPQ	5.0SMDJ36CA-Q	5BFPQ	40.00	44.20	1	36.0	2	58.1	86.1
5.0SMDJ40A-Q	5PFRQ	5.0SMDJ40CA-Q	5BFRQ	44.40	49.10	1	40.0	2	64.5	77.6
5.0SMDJ43A-Q	5PFTQ	5.0SMDJ43CA-Q	5BFTQ	47.80	52.80	1	43.0	2	69.4	72.1
5.0SMDJ45A-Q	5PFVQ	5.0SMDJ45CA-Q	5BFVQ	50.00	55.30	1	45.0	2	72.7	68.8
5.0SMDJ48A-Q	5PFXQ	5.0SMDJ48CA-Q	5BFXQ	53.30	58.90	1	48.0	2	77.4	64.7
5.0SMDJ51A-Q	5PFZQ	5.0SMDJ51CA-Q	5BFZQ	56.70	62.70	1	51.0	2	82.4	60.7
5.0SMDJ54A-Q	5RGEQ	5.0SMDJ54CA-Q	5BGEQ	60.00	66.30	1	54.0	2	87.1	57.5
5.0SMDJ58A-Q	5PGGQ	5.0SMDJ58CA-Q	5BGGQ	64.40	71.20	1	58.0	2	93.6	53.5
5.0SMDJ60A-Q	5PGKQ	5.0SMDJ60CA-Q	5BGKQ	66.70	73.70	1	60.0	2	96.8	51.7
5.0SMDJ64A-Q	5PGMQ	5.0SMDJ64CA-Q	5BGMQ	71.10	78.60	1	64.0	2	103.0	48.6
5.0SMDJ70A-Q	5PGPQ	5.0SMDJ70CA-Q	5BGPQ	77.80	86.00	1	70.0	2	113.0	44.3
5.0SMDJ75A-Q	5PGRQ	5.0SMDJ75CA-Q	5BGRQ	83.30	92.10	1	75.0	2	121.0	41.4
5.0SMDJ78A-Q	5PGTQ	5.0SMDJ78CA-Q	5BGTQ	86.70	95.80	1	78.0	2	126.0	39.7
5.0SMDJ85A-Q	5PGVQ	5.0SMDJ85CA-Q	5BGVQ	94.40	104.00	1	85.0	2	137.0	36.5

Continued on next page

Note:

- 'Q' suffix denotes AEC-Q101 compliance.

Specifications are subject to change without notice.

Users should verify actual device performance in their specific applications.

The products described herein and this document are subject to specific legal disclaimers as set forth on the last page of this document, and at www.bourns.com/docs/legal/disclaimer.pdf.

5.0SMDJ-Q Transient Voltage Suppressor Diode Series



Electrical Characteristics (@ T_A = 25 °C Unless Otherwise Noted) - Continued

Unidirectional Device		Bidirectional Device		Breakdown Voltage V _{BR} (Volts)			Reverse Standoff Voltage	Maximum Reverse Leakage @ V _{RWM}	Maximum Clamping Voltage @ I _{PP}	Peak Pulse Current
Part Number	Part Marking	Part Number	Part Marking	Min.	Max.	@ I _T (mA)	V _{RWM} (V)	I _R (μA)	V _C (V)	I _{PP} (A)
5.0SMDJ90A-Q	5PGXQ			100.00	111.00	1	90.0	2	146.0	34.3
5.0SMDJ100A-Q	5PGZQ			111.00	123.00	1	100.0	2	162.0	30.9
5.0SMDJ110A-Q	5PHEQ			122.00	135.00	1	110.0	2	177.0	28.3
5.0SMDJ120A-Q	5PHGQ			133.00	147.00	1	120.0	2	193.0	26.0
5.0SMDJ130A-Q	5PHKQ			144.00	159.00	1	130.0	2	209.0	24.0
5.0SMDJ150A-Q	5PHMQ			167.00	185.00	1	150.0	2	243.0	20.6
5.0SMDJ160A-Q	5PHPQ			178.00	197.00	1	160.0	2	259.0	19.3
5.0SMDJ170A-Q	5PHRQ			189.00	209.00	1	170.0	2	275.0	18.2

Product Dimensions

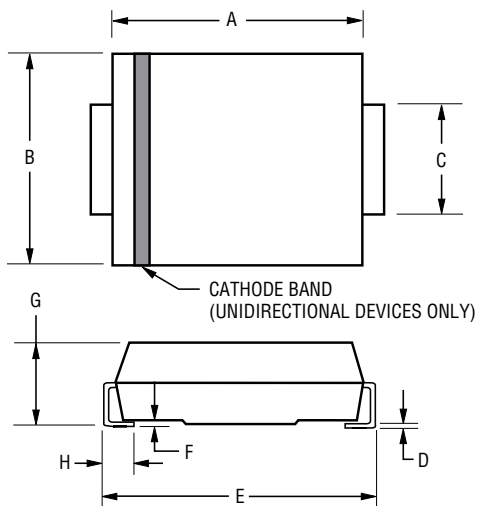

Dimension	SMC (DO-214AB)
A	$\frac{6.60 - 7.11}{(0.260 - 0.280)}$
B	$\frac{5.59 - 6.22}{(0.220 - 0.245)}$
C	$\frac{2.90 - 3.20}{(0.114 - 0.126)}$
D	$\frac{0.15 - 0.31}{(0.006 - 0.012)}$
E	$\frac{7.75 - 8.13}{(0.305 - 0.320)}$
F	$\frac{0.20}{(0.008)}$ MAX.
G	$\frac{2.01 - 2.62}{(0.080 - 0.103)}$
H	$\frac{0.76 - 1.52}{(0.030 - 0.060)}$

DIMENSIONS: $\frac{\text{MM}}{\text{(INCHES)}}$

Recommended Footprint

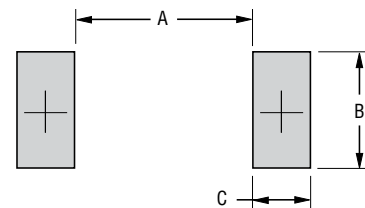

Dimension	SMC (DO-214AB)
A (Max.)	$\frac{4.69}{(0.185)}$
B (Min.)	$\frac{3.07}{(0.121)}$
C (Min.)	$\frac{1.53}{(0.060)}$

DIMENSIONS: $\frac{\text{MM}}{\text{(INCHES)}}$

Physical Specifications

Encapsulation.....Molded plastic per UL Class 94V-0
 Polarity..... Cathode band indicates unidirectional device
 No cathode band indicates bidirectional device

Environmental Specifications

Moisture Sensitivity Level..... 1
 ESD Classification (HBM)..... 3B

Specifications are subject to change without notice.

Users should verify actual device performance in their specific applications.

The products described herein and this document are subject to specific legal disclaimers as set forth on the last page of this document, and at www.bourns.com/docs/legal/disclaimer.pdf.

5.0SMDJ-Q Transient Voltage Suppressor Diode Series



Rating & Characteristic Curves

Pulse Derating Curve

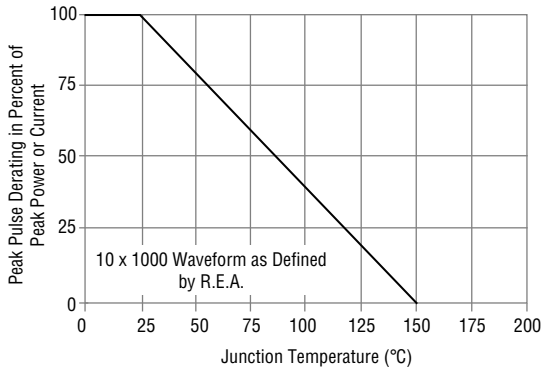

Maximum Non-Repetitive Surge Current

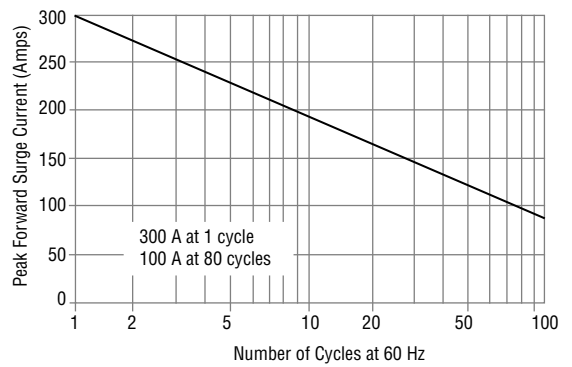

Pulse Waveform

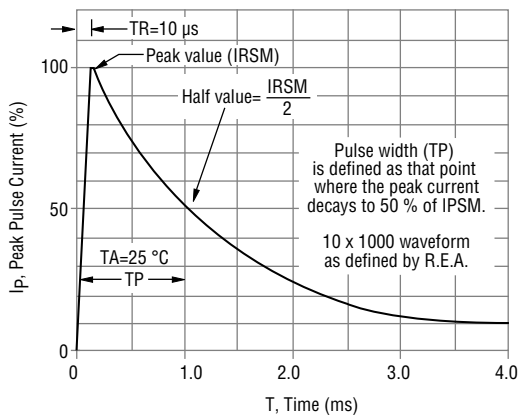

Typical Junction Capacitance

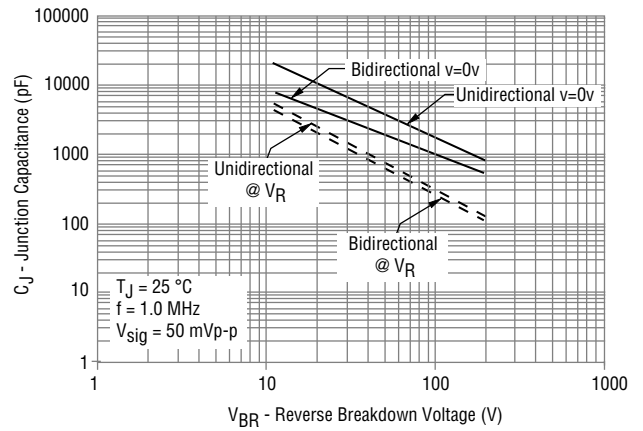

Pulse Rating Curve

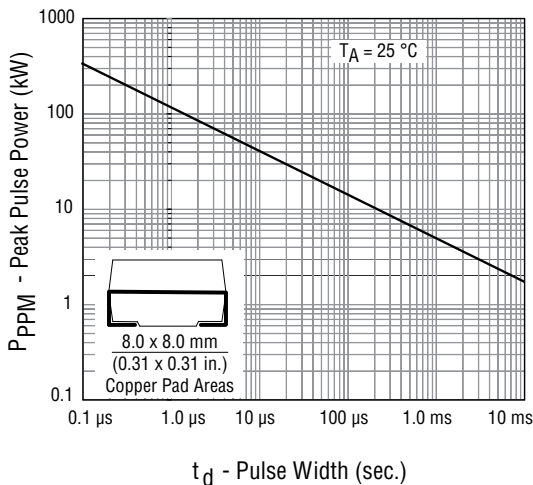

Steady State Power Derating Curve

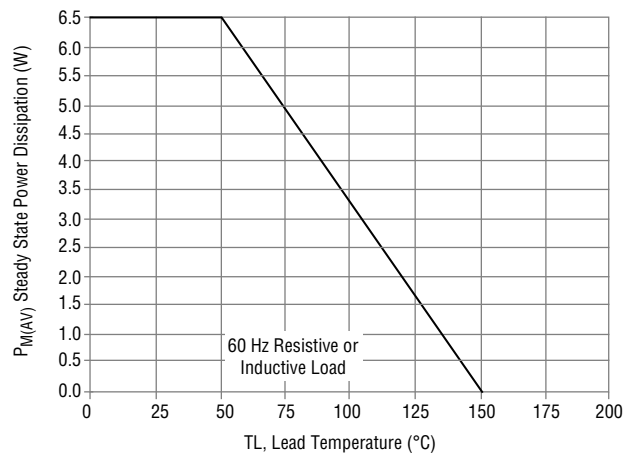

Specifications are subject to change without notice.

Users should verify actual device performance in their specific applications.

The products described herein and this document are subject to specific legal disclaimers as set forth on the last page of this document, and at www.bourns.com/docs/legal/disclaimer.pdf.

5.0SMDJ-Q Transient Voltage Suppressor Diode Series

BOURNS®

Packaging Information

The product will be dispensed in tape and reel format (see diagram below).

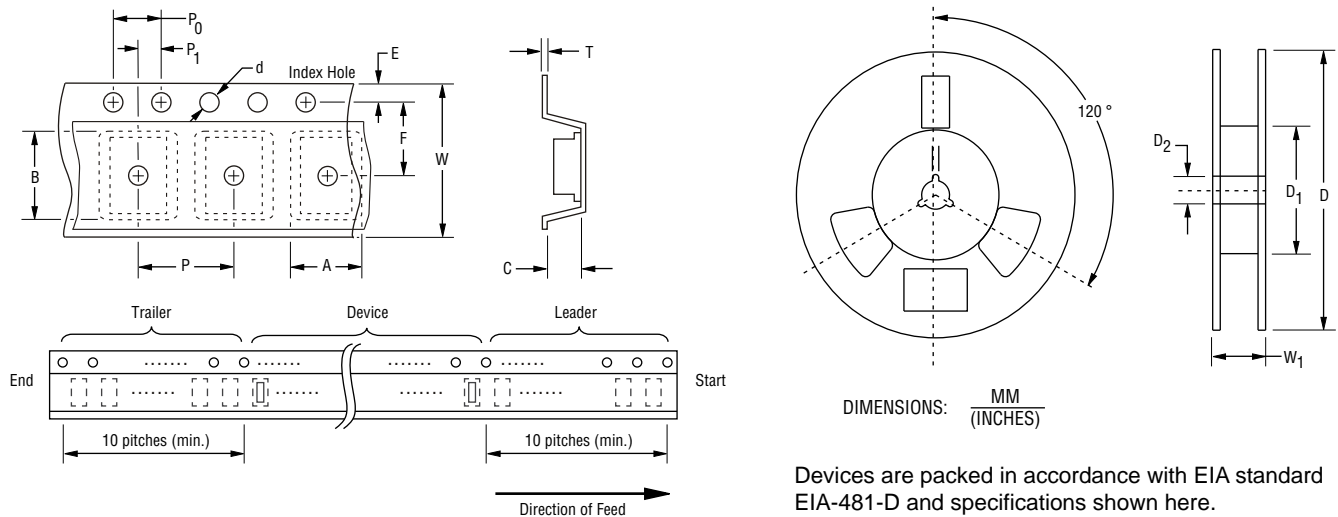

Devices are packed in accordance with EIA standard EIA-481-D and specifications shown here.

Item	Symbol	SMC (DO-214AB)	
		7-Inch Reel	13-Inch Reel
Carrier Width	A	6.0 ± 0.20 (0.236 ± 0.079)	
Carrier Length	B	8.3 ± 0.20 (0.327 ± 0.008)	
Carrier Depth	C	2.5 ± 0.20 (0.098 ± 0.008)	
Sprocket Hole	d	1.50 ± 0.10 (0.059 ± 0.004)	
Reel Outside Diameter	D	$\frac{178}{(7.008)}$	$\frac{330}{(12.992)}$
Reel Inner Diameter	D ₁	$\frac{50.0}{(1.969)}$ MIN.	
Feed Hole Diameter	D ₂	$\frac{13.0 + 0.50/-0.20}{(0.512 + 0.020/-0.008)}$	
Sprocket Hole Position	E	$\frac{1.75 \pm 0.10}{(0.069 \pm 0.004)}$	
Punch Hole Position	F	$\frac{7.50 \pm 0.10}{(0.295 \pm 0.004)}$	
Punch Hole Pitch	P	$\frac{8.00 \pm 0.10}{(0.315 \pm 0.004)}$	
Sprocket Hole Pitch	P ₀	$\frac{4.00 \pm 0.10}{(0.157 \pm 0.004)}$	
Embossment Center	P ₁	$\frac{2.00 \pm 0.10}{(0.079 \pm 0.004)}$	
Overall Tape Thickness	T	0.30 ± 0.10 (0.012 ± 0.004)	
Tape Width	W	$\frac{16.00 \pm 0.30}{(0.630 \pm 0.012)}$	
Reel Width	W ₁	$\frac{22.4}{(0.882)}$ MAX.	
Quantity per Reel	--	500	3,000

REV. 09/19

Specifications are subject to change without notice.

Users should verify actual device performance in their specific applications.

The products described herein and this document are subject to specific legal disclaimers as set forth on the last page of this document, and at www.bourns.com/docs/legal/disclaimer.pdf.

This legal disclaimer applies to purchasers and users of Bourns® products manufactured by or on behalf of Bourns, Inc. and its affiliates (collectively, “Bourns”).

Unless otherwise expressly indicated in writing, Bourns® products and data sheets relating thereto are subject to change without notice. Users should check for and obtain the latest relevant information and verify that such information is current and complete before placing orders for Bourns® products.

The characteristics and parameters of a Bourns® product set forth in its data sheet are based on laboratory conditions, and statements regarding the suitability of products for certain types of applications are based on Bourns’ knowledge of typical requirements in generic applications. The characteristics and parameters of a Bourns® product in a user application may vary from the data sheet characteristics and parameters due to (i) the combination of the Bourns® product with other components in the user’s application, or (ii) the environment of the user application itself. The characteristics and parameters of a Bourns® product also can and do vary in different applications and actual performance may vary over time. Users should always verify the actual performance of the Bourns® product in their specific devices and applications, and make their own independent judgments regarding the amount of additional test margin to design into their device or application to compensate for differences between laboratory and real world conditions.

Unless Bourns has explicitly designated an individual Bourns® product as meeting the requirements of a particular industry standard (e.g., ISO/TS 16949) or a particular qualification (e.g., UL listed or recognized), Bourns is not responsible for any failure of an individual Bourns® product to meet the requirements of such industry standard or particular qualification. Users of Bourns® products are responsible for ensuring compliance with safety-related requirements and standards applicable to their devices or applications.

Bourns® products are not recommended, authorized or intended for use in nuclear, lifesaving, life-critical or life-sustaining applications, nor in any other applications where failure or malfunction may result in personal injury, death, or severe property or environmental damage. Unless expressly and specifically approved in writing by two authorized Bourns representatives on a case-by-case basis, use of any Bourns® products in such unauthorized applications might not be safe and thus is at the user’s sole risk. Life-critical applications include devices identified by the U.S. Food and Drug Administration as Class III devices and generally equivalent classifications outside of the United States.

Bourns expressly identifies those Bourns® standard products that are suitable for use in automotive applications on such products’ data sheets in the section entitled “Applications.” Unless expressly and specifically approved in writing by two authorized Bourns representatives on a case-by-case basis, use of any other Bourns® standard products in an automotive application might not be safe and thus is not recommended, authorized or intended and is at the user’s sole risk. If Bourns expressly identifies a sub-category of automotive application in the data sheet for its standard products (such as infotainment or lighting), such identification means that Bourns has reviewed its standard product and has determined that if such Bourns® standard product is considered for potential use in automotive applications, it should only be used in such sub-category of automotive applications. Any reference to Bourns® standard product in the data sheet as compliant with the AEC-Q standard or “automotive grade” does not by itself mean that Bourns has approved such product for use in an automotive application.

Bourns® standard products are not tested to comply with United States Federal Aviation Administration standards generally or any other generally equivalent governmental organization standard applicable to products designed or manufactured for use in aircraft or space applications. Bourns expressly identifies Bourns® standard products that are suitable for use in aircraft or space applications on such products’ data sheets in the section entitled “Applications.” Unless expressly and specifically approved in writing by two authorized Bourns representatives on a case-by-case basis, use of any other Bourns® standard product in an aircraft or space application might not be safe and thus is not recommended, authorized or intended and is at the user’s sole risk.

The use and level of testing applicable to Bourns® custom products shall be negotiated on a case-by-case basis by Bourns and the user for which such Bourns® custom products are specially designed. Absent a written agreement between Bourns and the user regarding the use and level of such testing, the above provisions applicable to Bourns® standard products shall also apply to such Bourns® custom products.

Users shall not sell, transfer, export or re-export any Bourns® products or technology for use in activities which involve the design, development, production, use or stockpiling of nuclear, chemical or biological weapons or missiles, nor shall they use Bourns® products or technology in any facility which engages in activities relating to such devices. The foregoing restrictions apply to all uses and applications that violate national or international prohibitions, including embargos or international regulations. Further, Bourns® products and Bourns technology and technical data may not under any circumstance be exported or re-exported to countries subject to international sanctions or embargoes. Bourns® products may not, without prior authorization from Bourns and/or the U.S. Government, be resold, transferred, or re-exported to any party not eligible to receive U.S. commodities, software, and technical data.

To the maximum extent permitted by applicable law, Bourns disclaims (i) any and all liability for special, punitive, consequential, incidental or indirect damages or lost revenues or lost profits, and (ii) any and all implied warranties, including implied warranties of fitness for particular purpose, non-infringement and merchantability.

For your convenience, copies of this Legal Disclaimer Notice with German, Spanish, Japanese, Traditional Chinese and Simplified Chinese bilingual versions are available at:

Web Page: <http://www.bourns.com/legal/disclaimers-terms-and-policies>

PDF: <http://www.bourns.com/docs/Legal/disclaimer.pdf>

Компания «Life Electronics» занимается поставками электронных компонентов импортного и отечественного производства от производителей и со складов крупных дистрибьюторов Европы, Америки и Азии.

С конца 2013 года компания активно расширяет линейку поставок компонентов по направлению коаксиальный кабель, кварцевые генераторы и конденсаторы (керамические, пленочные, электролитические), за счёт заключения дистрибьюторских договоров

Мы предлагаем:

- Конкуренспособные цены и скидки постоянным клиентам.
- Специальные условия для постоянных клиентов.
- Подбор аналогов.
- Поставку компонентов в любых объемах, удовлетворяющих вашим потребностям.
- Приемлемые сроки поставки, возможна ускоренная поставка.
- Доставку товара в любую точку России и стран СНГ.
- Комплексную поставку.
- Работу по проектам и поставку образцов.
- Формирование склада под заказчика.
- Сертификаты соответствия на поставляемую продукцию (по желанию клиента).
- Тестирование поставляемой продукции.
- Поставку компонентов, требующих военную и космическую приемку.
- Входной контроль качества.
- Наличие сертификата ISO.

В составе нашей компании организован Конструкторский отдел, призванный помогать разработчикам, и инженерам.

Конструкторский отдел помогает осуществить:

- Регистрацию проекта у производителя компонентов.
- Техническую поддержку проекта.
- Защиту от снятия компонента с производства.
- Оценку стоимости проекта по компонентам.
- Изготовление тестовой платы монтаж и пусконаладочные работы.



Тел: +7 (812) 336 43 04 (многоканальный)

Email: org@lifeelectronics.ru