

VSC8531

Single Port Gigabit Ethernet Copper PHY with RGMII/RMII Interfaces

Low-power, small form-factor Cu PHY with IEEE 802.3az Energy Efficient Ethernet (EEE) and Wake-on-LAN (WoL), with widest I/O LVCMOS support.

The VSC8531 device, offered in a tiny 6 mm x 6 mm single-row QFN package, is designed for space-constrained 10/100/1000BASE-T applications. It features integrated line-side termination to conserve board space, lower EMI, and improve system performance. Additionally, integrated RGMII version 2.0 standard timing compliant compensation eliminates the need for on-board delay lines.

The device supports the industry's widest range of LVCMOS levels for a parallel MAC interface including 1.5 V, 1.8 V, 2.5 V, and 3.3 V, as well as 1.2 V, 1.5 V, 1.8 V, 2.5 V, and 3.3 V support on the MDIO/MDC interface.

VSC8531 includes Microsemi's EcoEthernet™ 2.0 technology with Energy Efficient Ethernet and power saving features to reduce power based on link state and cable reach. It optimizes power consumption at all link operating speeds, and features Wake-on-LAN power management using magic packets.

Highlights

- EcoEthernet™ 2.0, with Energy Efficient Ethernet
- Widest voltage range, fully-compliant parallel MAC interface device
- Tiny 6 mm x 6 mm QFN package
- Configurable drive strength on MAC interface enables better control of system-level EMI/EMC

Applications

- 3D printers, 2D printers
- IoT applications, such as digital signage and eHealth
- Consumer electronics, such as CPE, UHD TV, media servers, and NAS

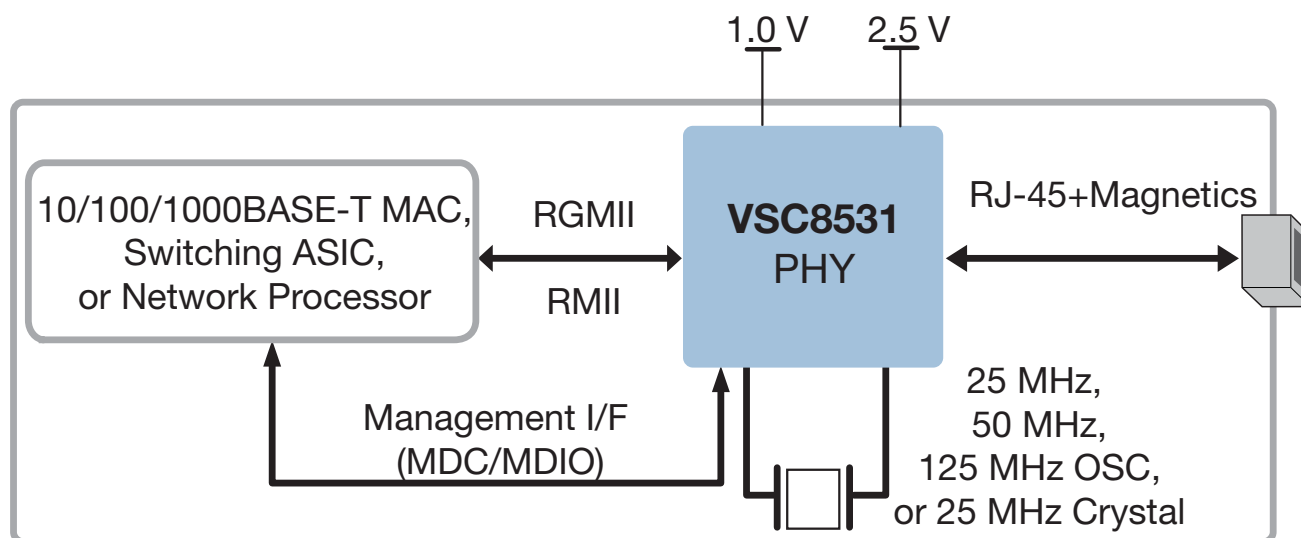

VSC8531

Single Port Gigabit Ethernet Copper PHY with RGMII/RMII Interfaces

Superior PHY and Interface Technology

- 10/100/1000BASE-T Ethernet copper transceiver (IEEE 802.3ab compliant) with Microsemi exclusive non-TDR based VeriPHY™ cable diagnostics software enables testing without taking down link or impacting data bandwidth while in 1000BASE-T mode
- Patented line driver with low-EMI voltage mode and integrated line-side termination resistors
- WOL support using magic packets
- HP Auto-MDIX and manual MDI/MDIX support
- RGMII/RMII MAC interface with widest voltage range support in the industry: 1.5 V, 1.8 V, 2.5 V, and 3.3 V (LVCMOS)
- Jumbo frame support up to 16 kilobytes with programmable synchronization FIFOs
- Additional internal FIFO located on ingress side enables support for EtherCAT® applications

Best-in-Class Power Consumption

- EcoEthernet™ 2.0 green energy efficiency with ActiPHY™, PerfectReach™, and IEEE 802.3az EEE
- Clause 45 registers to support IEEE 802.3az EEE and IEEE 802.3bf
- Fully optimized power consumption for all link speeds
- 10BASE-Te mode support enables even lower power consumption than 10BASE-T

Key Specifications

- Compliant with IEEE 802.3 (10BASE-T, 10BASE-Te, 100BASE-TX, and 1000BASE-T)

- Supports RGMII (version 1.3) and RMII (version 1.2) at 1.5 V, 1.8 V, 2.5 V, and 3.3 V LVCMOS
- RGMII version 2.0 timing compliant
- Supports clocking from 25 MHz crystal or 25/50/125 MHz oscillator
- Microcontroller-free configurability through hardware strapping
- Optionally reports if a link partner is requesting inline Power over Ethernet (PoE and PoE+)
- Optional stand-alone capability supports even the most cost-sensitive Ethernet enabled designs
- Devices support operating temperatures of -40 °C ambient to 125 °C junction or 0 °C ambient to 125 °C junction
- Available in 6 mm x 6 mm, 48-pin single-row QFN package

Related Products

Visit www.microsemi.com for information about these related products:

- VSC8541/VSC8541-03: Single Port Gigabit Ethernet Copper PHY with GMII/RGMII/RMII/MII Interface
- VSC8540-03: Single Port Fast Ethernet Copper PHY with Synchronous Ethernet, RGMII/MII/RMII Interface
- VSC8530-03: Single Port Industrial Grade Fast Ethernet Copper PHY with RGMII/RMII Interface

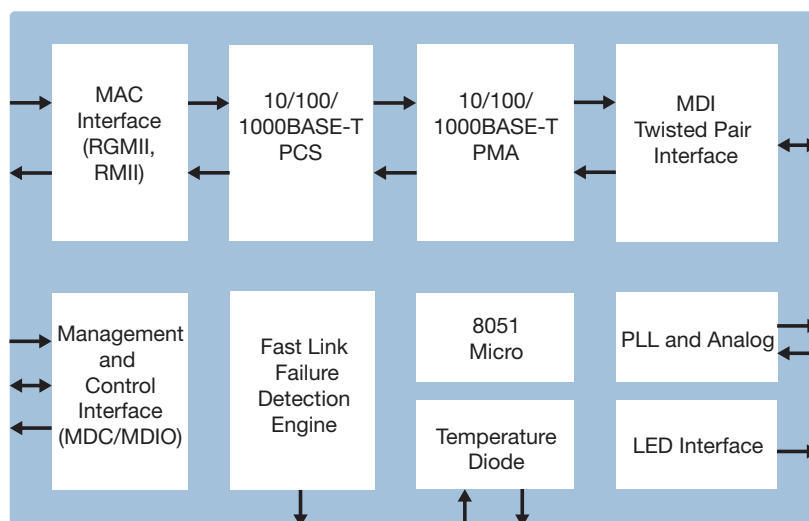

Microsemi Corporate Headquarters
 One Enterprise, Aliso Viejo, CA 92656 USA
 Within the USA: +1 (800) 713-4113
 Outside the USA: +1 (949) 380-6100
 Sales: +1 (949) 380-6136
 Fax: +1 (949) 215-4996
 email: sales.support@microsemi.com
www.microsemi.com

Microsemi Corporation (Nasdaq: MSCC) offers a comprehensive portfolio of semiconductor and system solutions for communications, defense & security, aerospace and industrial markets. Products include high-performance and radiation-hardened analog mixed-signal integrated circuits, FPGAs, SoCs and ASICs; power management products; timing and synchronization devices and precise time solutions, setting the world's standard for time; voice processing devices; RF solutions; discrete components; enterprise storage and communication solutions, security technologies and scalable anti-tamper products; Ethernet solutions; Power-over-Ethernet ICs and midspans; as well as custom design capabilities and services. Microsemi is headquartered in Aliso Viejo, Calif., and has approximately 4,800 employees globally. Learn more at www.microsemi.com.

Компания «Life Electronics» занимается поставками электронных компонентов импортного и отечественного производства от производителей и со складов крупных дистрибьюторов Европы, Америки и Азии.

С конца 2013 года компания активно расширяет линейку поставок компонентов по направлению коаксиальный кабель, кварцевые генераторы и конденсаторы (керамические, пленочные, электролитические), за счёт заключения дистрибьюторских договоров

Мы предлагаем:

- Конкурентоспособные цены и скидки постоянным клиентам.
- Специальные условия для постоянных клиентов.
- Подбор аналогов.
- Поставку компонентов в любых объемах, удовлетворяющих вашим потребностям.
- Приемлемые сроки поставки, возможна ускоренная поставка.
- Доставку товара в любую точку России и стран СНГ.
- Комплексную поставку.
- Работу по проектам и поставку образцов.
- Формирование склада под заказчика.
- Сертификаты соответствия на поставляемую продукцию (по желанию клиента).
- Тестирование поставляемой продукции.
- Поставку компонентов, требующих военную и космическую приемку.
- Входной контроль качества.
- Наличие сертификата ISO.

В составе нашей компании организован Конструкторский отдел, призванный помогать разработчикам, и инженерам.

Конструкторский отдел помогает осуществить:

- Регистрацию проекта у производителя компонентов.
- Техническую поддержку проекта.
- Защиту от снятия компонента с производства.
- Оценку стоимости проекта по компонентам.
- Изготовление тестовой платы монтаж и пусконаладочные работы.



Тел: +7 (812) 336 43 04 (многоканальный)

Email: org@lifeelectronics.ru