

THIS DRAWING IS UNPUBLISHED. RELEASED FOR PUBLICATION NOV ,2007.  
 © COPYRIGHT 2007 By - ALL RIGHTS RESERVED.

PROJECT	PRJ-14-000004825
PART NO	X-2823450-X
HV DESC	M12, A-CODED,RAIL FEMALE CRIMP
CUSTOMER	GENERAL MARKET

CABLE SOCKET AS SHOWN (5 POSITION)  
 (SEE SHEET 2 FOR CHILD PART DETAILS)

P	LTR	DESCRIPTION	DATE	DWN	APVD
	A3	ECR-16-014891	01MAR2017	KK	SE

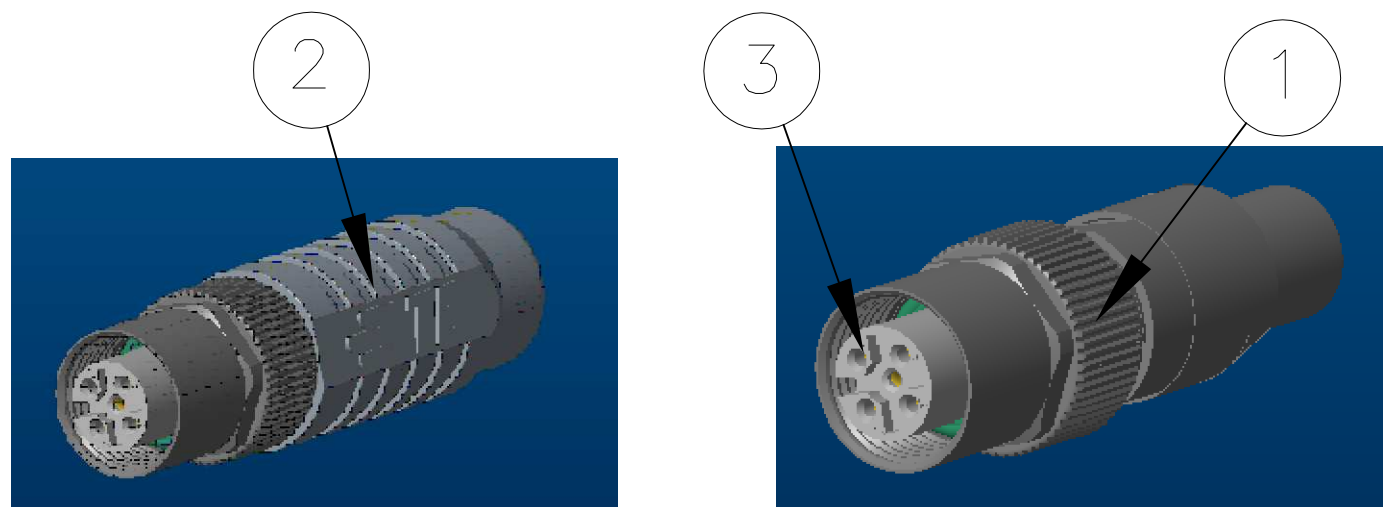
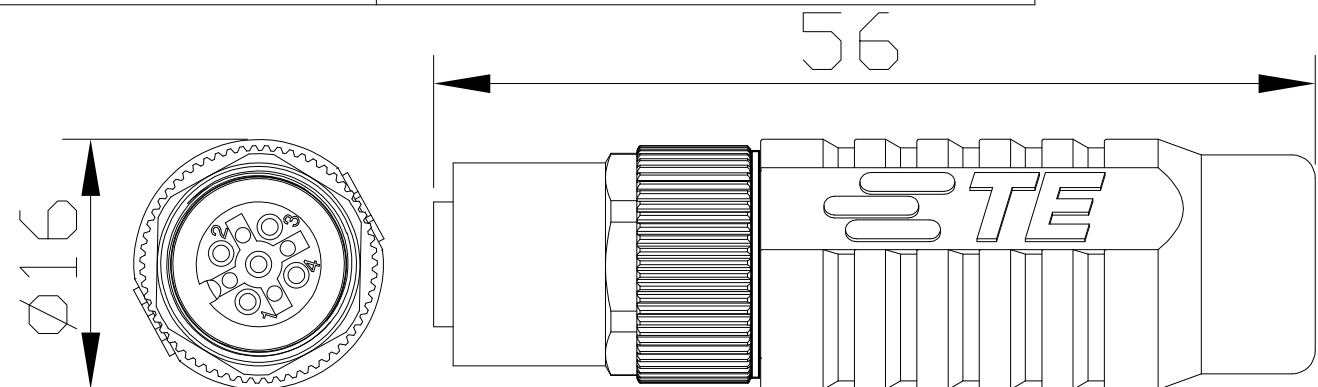

CODE	TE FG PN'S	NUMBER OF POLES IN CONNECTOR	NUMBER OF CONTACTS REQUIRED	CABLE SOCKET	CABLE REFERENCE	AWG	HAND TOOL (TE PN) (COMPACT)	HAND TOOL (TE PN) (STANDARD)	RECOMMENDED POSITIONER (TE PN) (COMPACT)	RECOMMENDED POSITIONER (TE PN) (STANDARD)	CRIMP TOOL TE PN FOR CRIMP FLANGE/SLEEVE	CRIMP INSERT TE PN'S	CABLE JACKET STRIPPING TOOL TE PN	ASSEMBLY TOOL HANDLE FOR CRIMP FLANGE TE PN	UNIVERSAL INSERT TE PN (ALL M12 CODES)	ASSEMBLY TOOL FRONT HOUSING AND BACK NUT TE PN	CABLE COLOUR	NUMBER OF WIRES PER CABLE	CABLE MANUFACTURER	CABLE PN
A code	1-2823450-1	5	4	x	Cat 5 Radox 6.6mm	AWG22			TE: 601966-2 (AWG22)	TE: 1-2823582-4 (SEL No.7)		1-2823558-3					BLACK	4	H & S	12584038
A code	1-2823450-2	5	4	x	Cat 5 Radox 7.3mm	AWG22			TE: 601966-2 (AWG22)	TE: 1-2823582-4 (SEL No.7)		1-2823558-4					BLACK	4	H & S	12568935
A code	1-2823450-3	5	4	x	Cat 5 Radox 8.3mm	AWG20			TE: 601966-2 (AWG20)	TE: 1-2823582-4 (SEL No.7)		1-2823558-6					BLACK	4	H & S	12585489
A code	1-2823450-4	8	4	x	Cat 5 Radox 7.3mm	AWG22	TE PN : 601966-1	TE PN : 601967-1	TE: 1-2823582-9	TE: 1-2823582-6 (AWG24)	1-2823557-1	1-2823558-4	1-2823559-1	1-2823560-1	1-2823561-1	1-2823564-1	BLACK	4	H & S	12568935
A code	1-2823450-5	8	4	x	Cat 5 Radox 6.6mm	AWG22			TE: 1-2823582-9	TE: 1-2823582-6 (AWG24)		1-2823558-3					BLACK	4	H & S	12584038
A code	1-2823450-6	8	4	x	TE CAT 7	AWG24			TE: 1-2823582-9 SETTINGS: (SEL No.5)	TE: 1-2823582-6 (AWG24)		1-2823558-5					BLUE	8	TE	2297799-1
A code	1-2823450-7	5	4	x	TE CAT 7	AWG24			TE: 601966-2, SETTINGS: (SEL No.5)	TE: 1-2823582-4 (AWG24)		1-2823558-5					BLUE	8	TE	2297799-1

NOTES:  
 MATERIAL:  
 ITEM NO. 1: HOUSING - BRASS, NICKEL PLATED.  
 ITEM NO. 2: PLASTIC BODY - PA (UL94 V-0).  
 ITEM NO. 3: CONTACT FINISH - Au (gold).  
 CONTACT - CuZn (Brass).  
 - ALL DIMENSIONS ARE FOR NOMINAL REFERENCE ONLY.  
 -PACKAGING: 1 PIECE IN A BAG.  
 -THE CONNECTOR IS AS PER IEC 61076-2-101.  
 -TEMPERATURE RANGE: -40°C TO 85°C (WITH CABLE BOOT),  
 -30°C TO 85°C (WITHOUT CABLE BOOT).  
 -VIBRATION & SHOCK TEST CONDUCTED AS PER IEC 61373:1999.  
 -FIRE PERFORMANCE CONDUCTED AS PER EN45545-2, NFF16-101 AND NFF16-102.  
 -THE THREAD OF THE MATING INTERLACE WITH THE COUNTERPART IS M12x1 ACCORDING TO IEC61076-2-101.  
 -REFER SPEC NO 408-156019 FOR INSTRUCTION SHEET (8 POSITION).  
 -REFER SPEC NO 408-156022 FOR INSTRUCTION SHEET (5 POSITION).  
 -CRIMP INSERT: SHOULD BE VALIDATED ON CABLE USED.  
 -CUSTOMER SHOULD SELECT THE CONTACTS POSITIONS,BASED ON HIS REQUIREMENT.  
 -WEIGHT 24 grams

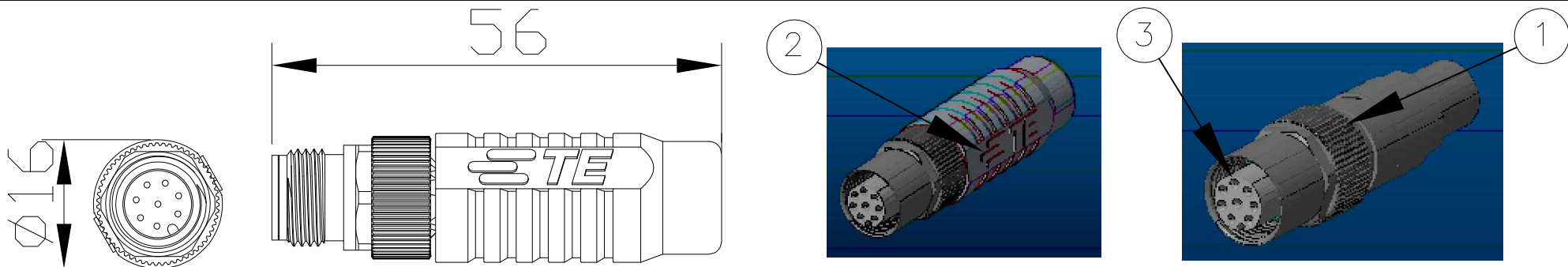

CABLE SOCKET AS SHOWN (8 POSITION) (SEE SHEET 2 FOR CHILD PART DETAILS)

THIS DRAWING IS A CONTROLLED DOCUMENT.		DWN	GUNA	09DEC2015	TE Connectivity NAME: M12, A-CODED RAIL FEMALE, CRIMP CONNECTORS			
DIMENSIONS: MM		CHK	GANI	09DEC2015				
TOLERANCES UNLESS OTHERWISE SPECIFIED:		APVD	JAYANTH	09DEC2015	PRODUCT SPEC			
0 PLC	± -	APPLICATION SPEC		108-156001		RESTRICTED TO		
1 PLC	± -	WEIGHT		114-156002		SIZE	CAGE CODE	DRAWING NO
2 PLC	± -	MATERIAL		-		A3	00779	C=2823450
3 PLC	± -	FINISH		-		CUSTOMER DRAWING		
4 PLC	± -	SCALE		NTS		SHEET		1 OF 2
ANGLES	± -	REV		A3				

THIS DRAWING IS UNPUBLISHED.		RELEASED FOR PUBLICATION NOV , 2007.	
© COPYRIGHT 2007 By -		ALL RIGHTS RESERVED.	
PROJECT	PRJ-14-000004825		
PART NO	X-2823450-X		
HV DESC	M12, A-CODED,RAIL FEMALE,CRIMP		
CUSTOMER	GENERAL MARKET		

P	LTR	DESCRIPTION	DATE	DWN	APVD
-	-	SEE SHEET 1	-	-	-

CABLE SOCKET AS SHOWN (5 POSITION)

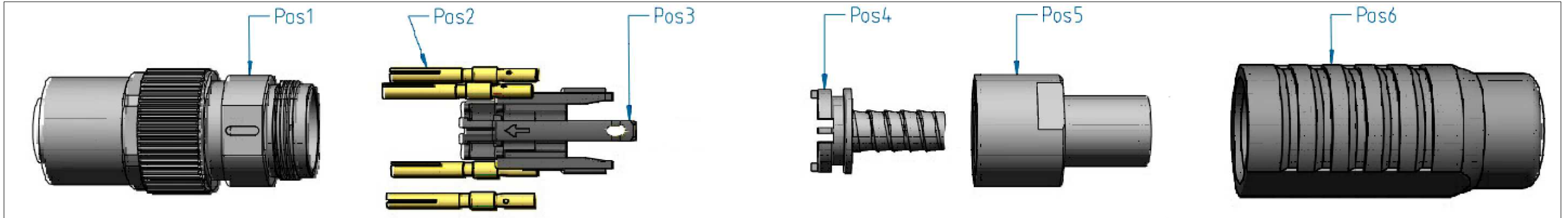

CABLE SOCKET AS SHOWN (8 POSITION)

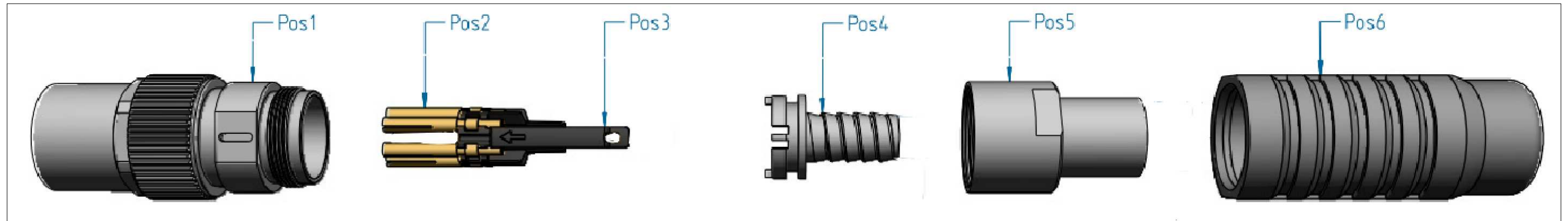

6	GRIP BOOT	1	PC
5	BACK NUT & CRIMP SLEEVE	1	PC
4	CRIMP INSERT	1	PC
3	CONTACT HOLDER	1	PC
2	CRIMP CONTACTS MACHINED	4	PC
1	FRONT HOUSING	1	PC
<b>Position</b>	<b>DESCRIPTION</b>	<b>QTY</b>	<b>UNIT</b>

THIS DRAWING IS A CONTROLLED DOCUMENT.		DWN GUNA 09DEC2015	TE Connectivity			
		CHK GANI 09DEC2015				
		APVD JAYANTH 09DEC2015	NAME			
		PRODUCT SPEC	M12, A-CODED RAIL FEMALE, CRIMP CONNECTORS			
		APPLICATION SPEC				
		WEIGHT	SIZE A3	CAGE CODE 00779	DRAWING NO C-2823450	RESTRICTED TO
CUSTOMER DRAWING		SCALE NTS	SHEET 2 OF 2	REV A3		

Компания «Life Electronics» занимается поставками электронных компонентов импортного и отечественного производства от производителей и со складов крупных дистрибьюторов Европы, Америки и Азии.

С конца 2013 года компания активно расширяет линейку поставок компонентов по направлению коаксиальный кабель, кварцевые генераторы и конденсаторы (керамические, пленочные, электролитические), за счёт заключения дистрибьюторских договоров

Мы предлагаем:

- Конкурентоспособные цены и скидки постоянным клиентам.
- Специальные условия для постоянных клиентов.
- Подбор аналогов.
- Поставку компонентов в любых объемах, удовлетворяющих вашим потребностям.
- Приемлемые сроки поставки, возможна ускоренная поставка.
- Доставку товара в любую точку России и стран СНГ.
- Комплексную поставку.
- Работу по проектам и поставку образцов.
- Формирование склада под заказчика.
- Сертификаты соответствия на поставляемую продукцию (по желанию клиента).
- Тестирование поставляемой продукции.
- Поставку компонентов, требующих военную и космическую приемку.
- Входной контроль качества.
- Наличие сертификата ISO.

В составе нашей компании организован Конструкторский отдел, призванный помогать разработчикам, и инженерам.

Конструкторский отдел помогает осуществить:

- Регистрацию проекта у производителя компонентов.
- Техническую поддержку проекта.
- Защиту от снятия компонента с производства.
- Оценку стоимости проекта по компонентам.
- Изготовление тестовой платы монтаж и пусконаладочные работы.



Тел: +7 (812) 336 43 04 (многоканальный)

Email: [org@lifeelectronics.ru](mailto:org@lifeelectronics.ru)