

## Video Accessory IC Series

# For portable image equipment Upscaler IC

BU1521GVW



No.09069EAT02

- Description

BU1521GVW upscales and interpolates images when upconverting to the HDTV (Maximum 1080P) format from the usual SDTV (NTSC/PAL) format.

High quality IP change · up scale management is realized by the frame memory less operate.

It is the LSI which is the most suitable for the compact system of the mobile.

- Features

- 1) Input format

480i or 576i(ITUR BT656) YCbCr 4:2:2(ITUR BT601) 8bit Digital Interface

- 2) Output Format

480i or 576i(ITUR BT656) YCbCr 4:2:2 8bit Digital Interface

480p or 576p(SMPTE 293 · ITUR BT1358) YCbCr 4:2:2 16bit Digital Interface

1080/59.94i(SMPTE 274) YCbCr 4:2:2 16bit Digital Interface

1080/50i(SMPTE 274) YCbCr 4:2:2 16bit Digital Interface

1080/59.94p(SMPTE 274) YCbCr 4:2:2 16bit Digital Interface

1080/50p(SMPTE 274) YCbCr 4:2:2 16bit Digital Interface

- 3) IP conversion function

Conversion function from interlace to progressive

- 4) Upscale function

Horizontal direction: 720 pixels pass-through or upscaling to 1920 pixels

Vertical direction: up scaling to 480, 576, 540, and 1080 pixels

- 5) Filter function

5 × 5 filtering function over input data

Filter coefficient is programmable with registers

- 6) Register access

Register read/write through the SPI interface

Burst write/read support

- 7) Built-in PLL

Input frequency 27MHz

Output frequency 74.25MHz, 74.175824MHz, 148.5MHz, 148.351648MHz

- 8) Power-down mode and through-mode support

Power-down mode can be controlled through STBY pin or register setting.

Through-mode can be selected by register setting.

- 9) Supply voltage

VDD(core voltage) 1.15V~1.25V、AVDD(PLL)=2.7V~3.3V、

VDDIO1(SDTV input)=1.7V~3.6V、VDDIO2(control)=2.7V~3.3V、

VDDIO3(HDTV output)=1.7V~1.9V

- 10) Package

63 pin, BGA package (SBGA063W060, Size = 6 mm × 6 mm, 0.65 mm pitch)

- Applications

Digital Video Camera, Digital still camera, Video game, a portable DVD

● Absolute Maximum Rating

Table. 1 Absolute maximum rating

Parameter	Symbol	Rating	Unit
Supply voltage 1 (SD input)	VDDIO1	-0.3~+4.2	V
Supply voltage 2 (Control)	VDDIO2	-0.3~+4.2	V
Supply voltage 3 (HD output)	VDDIO3	-0.3~+4.2	V
Supply voltage 4 (PLL)	AVDD	-0.3~+4.2	V
Supply voltage 5 (CORE)	VDD	-0.3~+1.68	V
Input voltage 1	VIN1	-0.3~VDDIO1+0.3	V
Input voltage 2	VIN2	-0.3~VDDIO2+0.3	V
Input voltage 3	VIN3	-0.3~VDDIO3+0.3	V
Storage temperature range	Tstg	-25~+125	°C
Power dissipation	PD	330*1, 1200*2	mW

\*1 IC only. In the case exceeding 25°C, 3.3 mW should be reduced at the rating 1°C.

\*2 When packaging a glass epoxy board of 114.3 × 76.2 × 1.6 mm. In the case exceeding 25°C, 12 mW should be reduced at the rating 1°C.

\* Has not been designed to withstand radiation.

\* Operation is not guaranteed.

● Operating Conditions

Table. 2 Operating conditions

Parameter	Symbol	Min	Typ	Max	Unit
Supply voltage 1 (SD input)	VDDIO1	1.7	3.3	3.6	V
Supply voltage 2 (Control)	VDDIO2	2.7	3.0	3.3	V
Supply voltage 3 (HD output)	VDDIO3	1.7	1.8	1.9	V
Supply voltage 4 (PLL)	AVDD	2.7	3.0	3.3	V
Supply voltage 5 (CORE)	VDD	1.15	1.2	1.25	V
Operating temperature range	Topr	-25	-	85	°C

● Electrical Characteristics (DC Characteristics)

Table. 3 Electric characteristics

Parameter	Symbol	Specification			Unit	Conditions
		MIN	TYP	MAX		
Operational current (CORE)	IDD1	-	150	200	mA	When operated with HDCLK = 148.5 MHz
Operational current (IO)	IDD2	-	40	80	mA	When operated with HDCLK = 148.5 MHz and external capacitor of 5pF
Operational current (CORE)	IDD3	-	15	20	mA	When operated with DCLK = 27 MHz
Operational current (IO)	IDD4	-	10	20	mA	When operated with HDCLK = 27 MHz and external capacitor of 5pF
Static current	IDDst	-	-	800	μA	In standby mode
Input "H" current	I <sub>IH</sub>	-10	-	10	μA	V <sub>IH</sub> =VDDIO1/2
Input "L" current	I <sub>IL</sub>	-10	-	10	μA	V <sub>IL</sub> =GND
Input "H" voltage 1	V <sub>IH1</sub>	VDDIO1 *0.8	-	VDDIO1 +0.3	V	Ordinary input (Including input mode of I/O pin)
Input "L" voltage 1	V <sub>IL1</sub>	-0.3	-	VDDIO1 *0.2	V	Ordinary input (Including input mode of I/O pin)
Input "H" voltage 2	V <sub>IH2</sub>	VDDIO1 *0.85	-	VDDIO1 +0.3	V	Hysteresis input
Input "L" voltage 2	V <sub>IL2</sub>	-0.3	-	VDDIO1 *0.15	V	Hysteresis input
Hysteresis voltage range 2	V <sub>hys2</sub>	-	0.75	-	V	Hysteresis input
Output "H" voltage 1	V <sub>OH1</sub>	VDDIO2 -0.4	-	VDDIO2	V	I <sub>OH1</sub> =-1.0mA(DC) SDOUT
Output "L" voltage 1	V <sub>OL1</sub>	0.0	-	0.4	V	I <sub>OL1</sub> =1.0mA(DC) SDOUT
Output "H" voltage 2	V <sub>OH2</sub>	VDDIO3 -0.2	-	VDDIO3	V	I <sub>OH1</sub> =-1.0mA(DC) HD output pin
Output "L" voltage 2	V <sub>OL2</sub>	0.0	-	0.2	V	I <sub>OL1</sub> =1.0mA(DC) HD output pin

(When not otherwise specified, under the conditions of VDD = 1.20 V, VDDIO1 = 3.3 V, VDDIO3 = 1.8 V, VDDIO2 = AVDD = 3.0 V, AVSS = GND = 0.0 V, and Ta = 25°C)

● Electrical Characteristics (AC Characteristics)

1. 3-wire serial interface timing

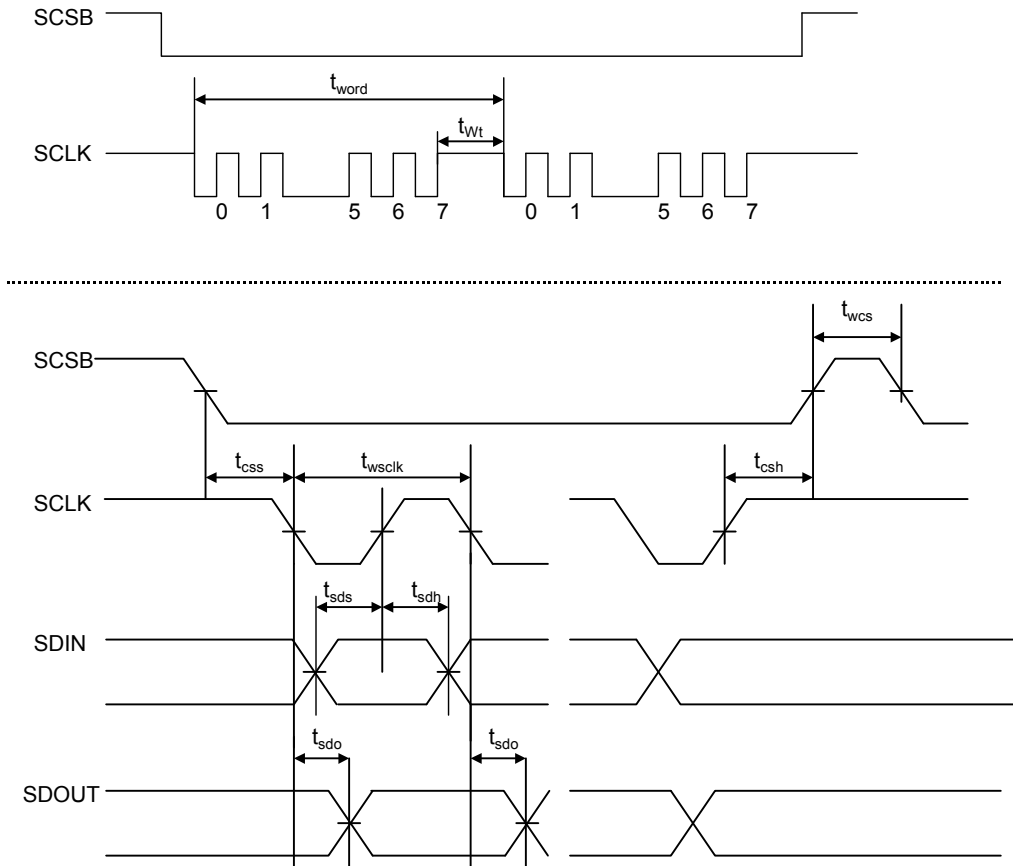

Fig. 1 3-wire serial interface format

Table. 4 3-wire serial interface format

Symbol	Description	MIN	TYP	MAX	Unit
$t_{wclk}$	SCLK clock cycle	200	-	-	ns
$t_{wcs}$	SCSB access interval	1	-	-	$\mu$ s
$t_{css}$	SCSB setup time	200	-	-	ns
$t_{sds}$	SDIN setup time	30	-	-	ns
$t_{csh}$	SCSB holding time	1	-	-	$\mu$ s
$t_{sdh}$	SDIN holding time	30	-	-	ns
$t_{sdo}$	Time from trailing of the clock to the establishment of SDOUT	-	-	60	ns
$t_{word}$	1 word write time	2.5	-	-	$\mu$ s
$t_{wt}$	1 word write interval	1	-	-	$\mu$ s

2. Image Data Input Timing

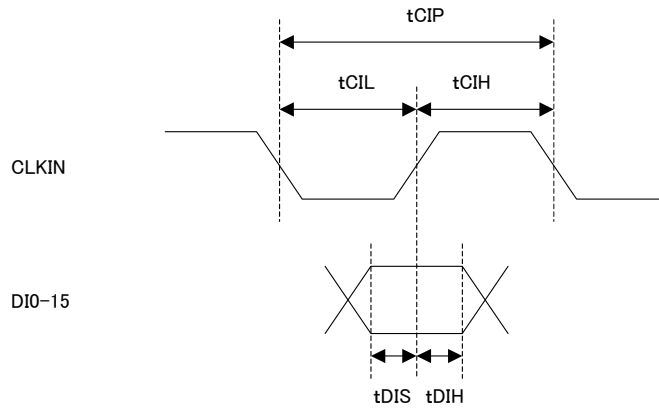

Fig. 2 Image Data Input Timing

Table. 5 Image Data Input Timing

Symbol	Description	MIN	TYP	MAX	Unit
$t_{CIP}$	CLKIN Clock cycle	-	37.03	-	ns
$d_{CKI}$	CLKIN clock duty ( $t_{CIL}/t_{CIP}$ or $t_{CIH}/t_{CIP}$ )	45	50	55	%
$t_{DIS}$	Data setup time from the CLKIN rise	2	-	-	ns
$t_{DIH}$	Data holding time from the CLKIN rise	3	-	-	ns

3. Image Data Output Timing

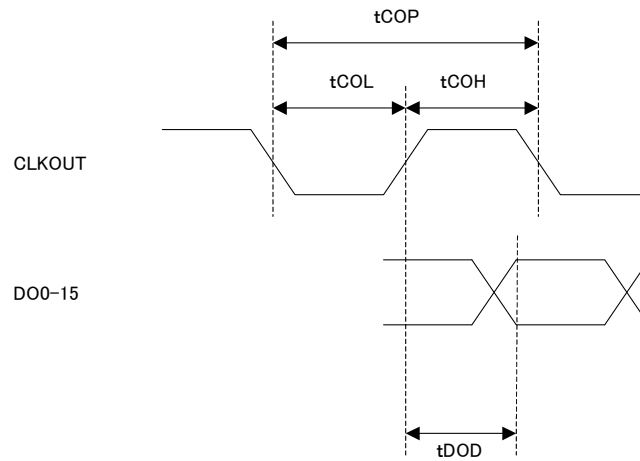

Fig. 3 Image Data Output Timing

Table. 6 Image Data Output Timing

Symbol	Description	MIN	TYP	MAX	Unit
$t_{COP}$	CLKOUT Clock cycle	6.734	-	-	ns
$d_{CKO}$	CLKOUT clock duty ( $t_{COL}/t_{COP}$ or $t_{COH}/t_{COP}$ ) *	45	-	55	%
$t_{DOD}$	Time from the rise of CLKOUT to the establishment of DO0-15	1	-	12	ns
$t_{DOD}$	Time from the rise of CLKOUT to the establishment of DO0-15	1	-	5.734	ns
$t_{JIT}$	Output jitter of CLKOUT (1 us cycle)	-	-	2	ns

\* When PLL is used. When 27 MHz is output, the input clock duty is 50%.

● Pin configuration diagram (Bottom View)

Fig. 4 Pin configuration diagram of BU1521GVW (Bottom view).

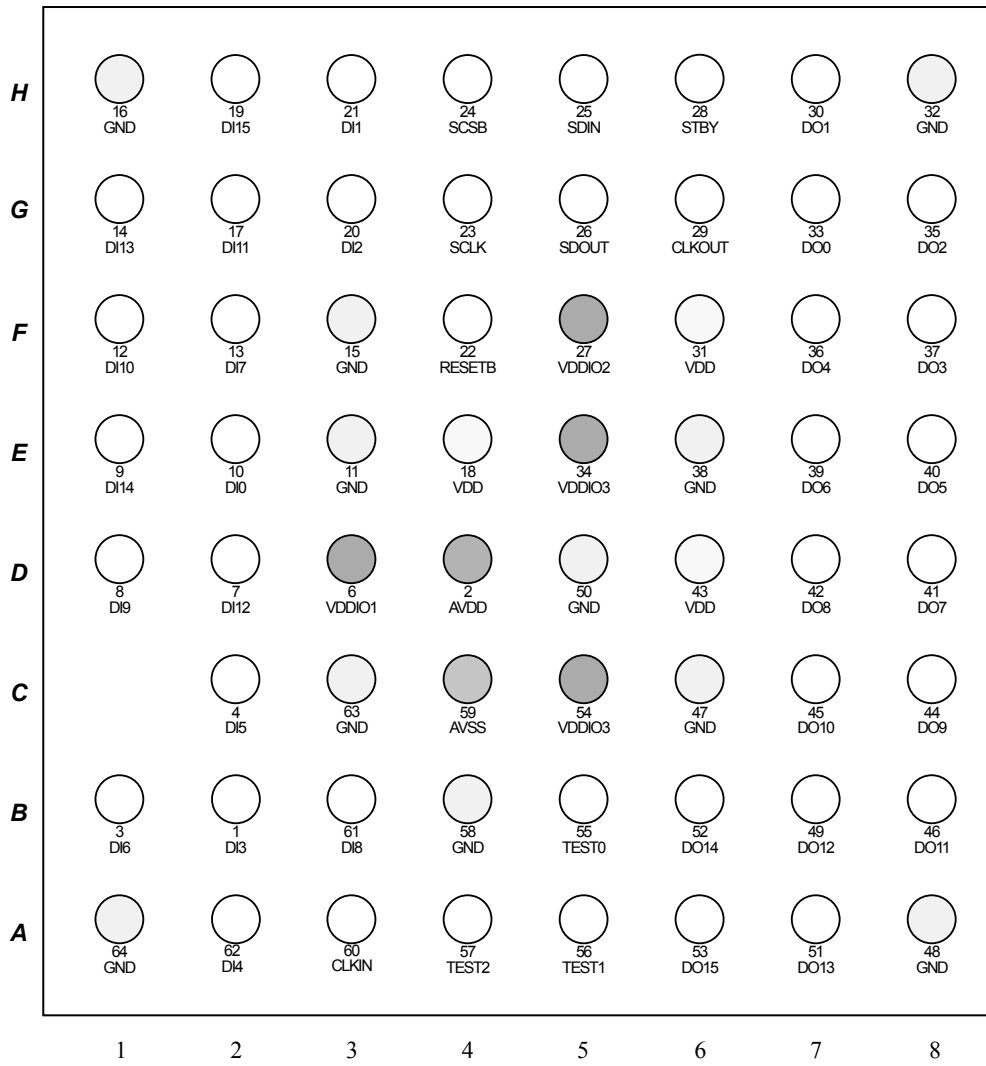

Fig. 4 BU1521GVW Pin configuration diagram(Bottom View)

## ● Pin Function

Table. 7 BU1521GVW terminal function(1)

PIN No.	Ball No.	PIN Name	In/Out	Init	Function Description	I/O Type	I/O System
1	B2	DI3	In	–	3rd bit of SD input data	B	VDDIO1
2	D4	AVDD	–	–	Power Source for PLL	–	–
3	B1	DI6	In	–	6th bit of SD input data	B	VDDIO1
4	C2	DI5	In	–	5th bit of SD input data	B	VDDIO1
5	–	N.C *1	–	–	–	–	–
6	D3	VDDIO1	–	–	Data input IO voltage (Typical 3.3 V)	–	–
7	D2	DI12	In	–	12th bit of SD input data	B	VDDIO1
8	D1	DI9	In	–	9th bit of SD input data	B	VDDIO1
9	E1	DI14	In	–	14th bit of SD input data	B	VDDIO1
10	E2	DI0	In	–	0th bit of SD input data	B	VDDIO1
11	E3	GND	–	–	GND	–	–
12	F1	DI10	In	–	10th bit of SD input data	B	VDDIO1
13	F2	DI7	In	–	7th bit of SD input data	B	VDDIO1
14	G1	DI13	In	–	13th bit of SD input data	B	VDDIO1
15	F3	GND	–	–	GND	–	–
16	H1	GND	–	–	GND	–	–
17	G2	DI11	In	–	11th bit of SD input data	B	VDDIO1
18	E4	VDD	–	–	Core power supply (1.2 V)	–	–
19	H2	DI15	In	–	15th bit of SD input data	B	VDDIO1
20	G3	DI2	In	–	2nd bit of SD input data	B	VDDIO1
21	H3	DI1	In	–	1st bit of SD input data	B	VDDIO1
22	F4	RESETB	In	–	Reset pin (low active)	B*2	VDDIO2
23	G4	SCLK	In	–	3-wire serial I/F clock	B*2	VDDIO2
24	H4	SCSB	In	–	3-wire serial I/F chip select	B*2	VDDIO2
25	H5	SDIN	In	–	3-wire serial I/F data input	B*2	VDDIO2
26	G5	SDOUT	Out	Low	3-wire serial I/F data output	C*3	VDDIO2
27	F5	VDDIO2	–	–	Control signal IO voltage (typically 3.3 V)	–	–
28	H6	STBY	In	–	IC stand-by control	A	VDDIO2
29	G6	CLKOUT	Out	Low	HD clock output	D	VDDIO3
30	H7	DO1	Out	PD	1st bit of HD output pin	C	VDDIO3
31	F6	VDD	–	–	Core power supply (1.2 V)	–	–
32	H8	GND	–	–	GND	–	–
33	G7	DO0	Out	PD	0th bit of HD output pin	C	VDDIO3
34	E5	VDDIO3	–	–	Data output IO voltage (typically 1.8 V)	–	–
35	G8	DO2	Out	PD	2nd bit of HD output pin	C	VDDIO3
36	F7	DO4	Out	PD	4th bit of HD output pin	C	VDDIO3
37	F8	DO3	Out	PD	3rd bit of HD output pin	C	VDDIO3
38	E6	GND	–	–	GND	–	–
39	E7	DO6	Out	PD	6th bit of HD output pin	C	VDDIO3
40	E8	DO5	Out	PD	5th bit of HD output pin	C	VDDIO3
41	D8	DO7	Out	PD	7th bit of HD output pin	C	VDDIO3

Table. 8 BU1521GVW terminal function(2)

PIN No.	Ball No.	PIN Name	In/Out	Init	Function Description	I/O Type	I/O System
42	D7	DO8	Out	PD	8th bit of HD output pin	C	VDDIO3
43	D6	VDD	-	-	Core power supply (1.2 V)	-	-
44	C8	DO9	Out	PD	9th bit of HD output pin	C	VDDIO3
45	C7	DO10	Out	PD	10th bit of HD output pin	C	VDDIO3
46	B8	DO11	Out	PD	11th bit of HD output pin	C	VDDIO3
47	C6	GND	-	-	GND	-	-
48	A8	GND	-	-	GND	-	-
49	B7	DO12	Out	PD	12th bit of HD output pin	C	VDDIO3
50	D5	GND	-	-	GND	-	-
51	A7	DO13	Out	PD	13th bit of HD output pin	C	VDDIO3
52	B6	DO14	Out	PD	14th bit of HD output pin	C	VDDIO3
53	A6	DO15	Out	PD	15th bit of HD output pin	C	VDDIO3
54	C5	VDDIO3	-	-	Data output IO voltage (Typical 1.8 V)	-	-
55	B5	TEST0	In	-	Test pin 0 (Connect to GND)	A	VDDIO3
56	A5	TEST1	In	-	Test pin 1 (Connect to GND)	A	VDDIO3
57	A4	TEST2	In	-	Test pin 2 (Connect to GND)	A	VDDIO3
58	B4	GND	-	-	GND	-	-
59	C4	AVSS	-	-	GND for PLL	-	-
60	A3	CLKIN	In	-	SD clock input (27 MHz)	B	VDDIO1
61	B3	DI8	In	-	8th bit of SD input data	B	VDDIO1
62	A2	DI4	In	-	4th bit of SD input data	B	VDDIO1
63	C3	GND	-	-	GND	-	-
64	A1	GND	-	-	GND	-	-

Init column indicates pin status when released from reset. Low: L output PD: Pull-down  
 \*1: No balls \*2: Input suspend function is fixed to OFF by an internal signal \*3: No pull-down function

● Block Diagram

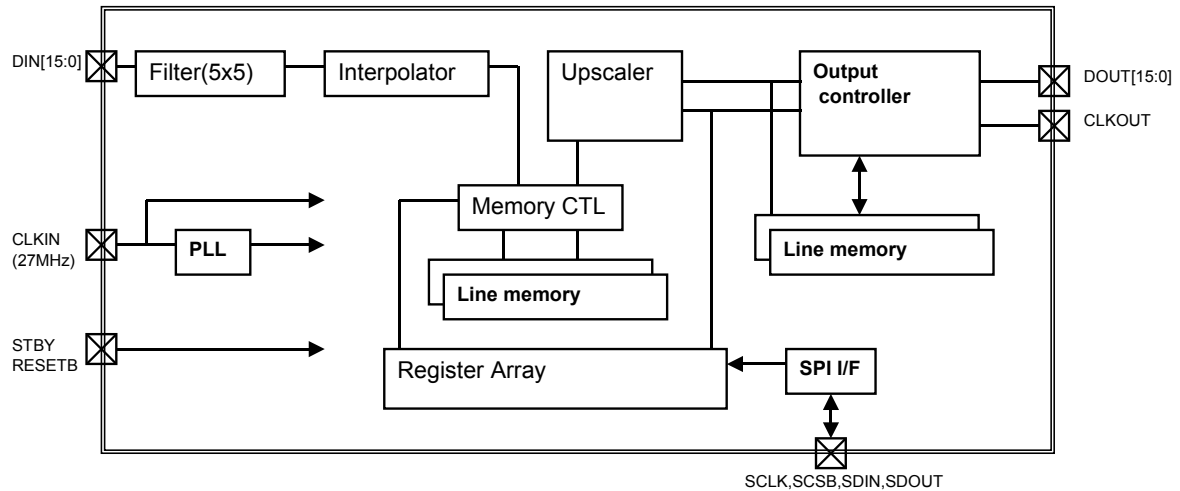

Fig. 5 BU1521GVW Block diagram

● Functions Discription

1. Input format

The following is the input format for BU1521GVW

480i or 576i(ITUR BT656) YCbCr 4:2:2 8bit(ITUR BT601) Digital Interface

Table. 9 Input format

Format	Data bit width	Pixel clock (MHz)	Size including blank (HxV)	Active Size (HxV)	Standard
480/59.94i	8	27	858x525	720x(244/243)	ITUR BT656-4
576/50i	8	27	864x625	720x(288/288)	

SYS2 register (0 × 12) setting allows applying whether Y data and CbCr data to be assigned to lower DI [7:0] or upper DI [15:8].

2. Output format

480 (I), 576 (I)

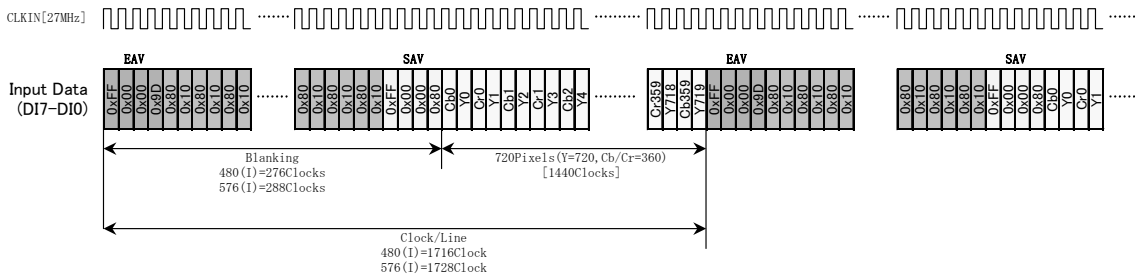

The following is the output format for BU1521GVW:

- 480i or 576i(ITUR BT656) YCbCr 4:2:2 8bit (ITUR BT601)Digital Interface
- 480p or 576p(ITUR BT1358) YCbCr 4:2:2 16bit(ITUR BT601) Digital Interface
- 1080/59.94i(SMPTE 274) YCbCr 4:2:2 16bit(ITUR BT601) Digital Interface
- 1080/50i(SMPTE 274) YCbCr 4:2:2 16bit(ITUR BT601) Digital Interface
- 1080/59.94p(SMPTE 274) YCbCr 4:2:2 16bit(ITUR BT601) Digital Interface
- 1080/50p(SMPTE 274) YCbCr 4:2:2 16bit(ITUR BT601) Digital Interface

Table. 10 Output format

Format	Data bit width	Pixel Clock Frequency (MHz)	Blanking Size including Line (HxV)	Active Image Size (HxV)	Standard
480/59.94i	8	27	858x525	720x(244/243)	ITUR BT656-4
576/50i	8	27	864x625	720x(288/288)	
480/59.94p	16	27	858x525	720x483	ITUR BT1358 SMPTE 293M
576/50p	16	27	864x625	720x576	
1080/59.94i	16	74.25/1.001	2200x1125	1920x1080	SMPTE 274
1080/50i	16	74.25	2640x1125	1920x1080	
1080/59.94p	16	148.5/1.001	2200x1125	1920x1080	
1080/50p	16	148.5	2640x1125	1920x1080	



3. IP conversion, upscale function

BU1521GVW upscales and interpolates images when upconverting to output format.

Supported image data I/O conversion is shown in Table. 11 .

Only input size of 720 or upscale to 1920 are supported for the horizontal direction.

The edge of the upscaled image can be enhanced (3 levels) by changing the UPC\_SEL register.

When upscaling the 480i input, upscaling is applied to 240 lines among the overall effective lines

Table. 11 Image data I/O conversion table

Input (SD)	Output (HD)							
	480/ 59.94i	480/ 59.94p	576/ 50i	576/ 50p	1080/ 59.94i	1080/ 50i	1080/ 59.94p	1080/ 50p
480/59.94i	○	○※	—	—	○	—	○	—
576/50i	—	—	○	○	—	○	—	○

\* Immediately after reset and when standby mode is set, 480i becomes 480p.

4. Filter function

BU1521GVW can apply 5 taps of filtering both horizontally and vertically.

5 taps of filter tap coefficients can be set independently on horizontal and vertical directions using filter coefficient registers (0x14–0x1B).

5 x 5 Filter tap coefficients = Horizontal filter tap coefficients x Vertical filter tap coefficients.

The values of the horizontal and vertical filter taps must be set to make the sum of the coefficients 64.

The initial value makes the filter invalid.

[Horizontal filter tap coefficients]

1	2	3	4	5
TH1	TH2	TH3	TH4	TH5

/64

[Vertical filter tap coefficients]

1	TV1
2	TV2
3	TV3
4	TV4
5	TV5

/64

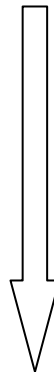
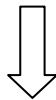

[5 x 5 filter tap coefficients]

行番号	列番号				
	1	2	3	4	5
1	TH1*TV1	TH2*TV1	TH3*TV1	TH4*TV1	TH5*TV1
2	TH1*TV2	TH2*TV2	TH3*TV2	TH4*TV2	TH5*TV2
3	TH1*TV3	TH2*TV3	TH3*TV3	TH4*TV3	TH5*TV3
4	TH1*TV4	TH2*TV4	TH3*TV4	TH4*TV4	TH5*TV4
5	TH1*TV5	TH2*TV5	TH3*TV5	TH4*TV5	TH5*TV5

/4096

Fig. 6 5 x 5 filter tap coefficients

5. Register access

Registers are accessed by 3 wire serial interfaces (SCSB, SCLK, SDIN, SDOUT).

Burst write/read is supported; therefore, consecutive writing is possible.

◆ Regular write sequence

The address 8 bits and data 8 bits should be written in this order.

Both address and data have MSB first.

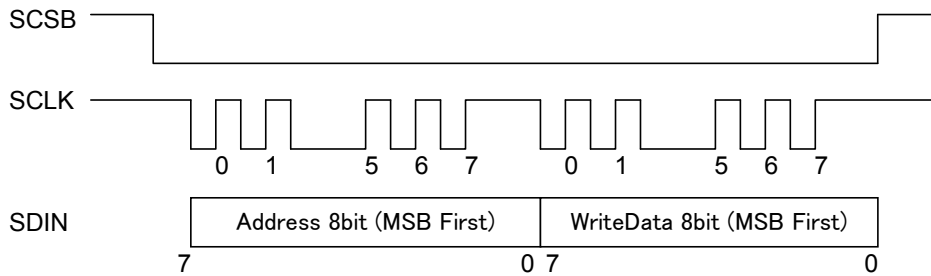

Fig. 7 Regular write sequence

◆ Regular read sequence

For reading, the address of the register to be read out should be written in the SADR register (0 × 70), then SRDAT register (0 × 80) should be read out.

Both address and data have MSB first.

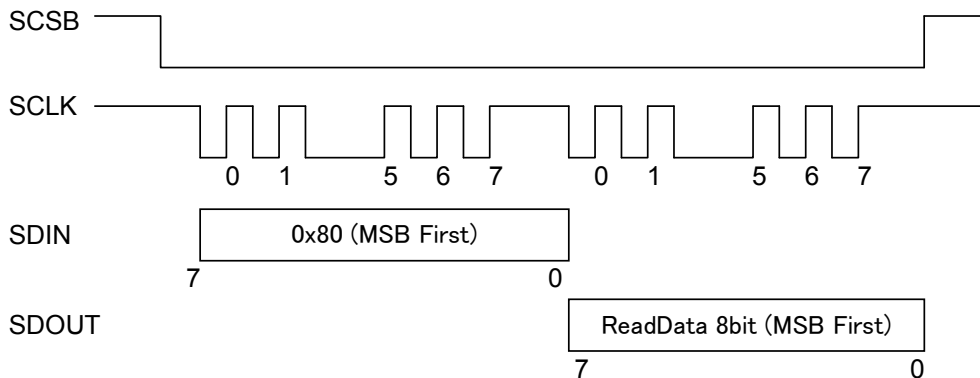

Fig. 8 Regular read sequence

6. PLL

BU1521GVW has an integrated PLL to generate and output the clock for HD format from the 27 MHz pixel clock.

The PLL output frequency is selected and output is executed according to the output format only, by setting the output format to the register.

The input frequency is 27 MHz and the output frequency can be 74.25 MHz, 74.25/1.001 MHz, 148.5 MHz, or 148.5/1.001 MHz.

With 480i/576i output format, the 27 MHz input clock is output without going through the PLL.

● Typical application circuit

The typical application circuit of BU1521GVW is shown in Fig. 9 It does not guarantee

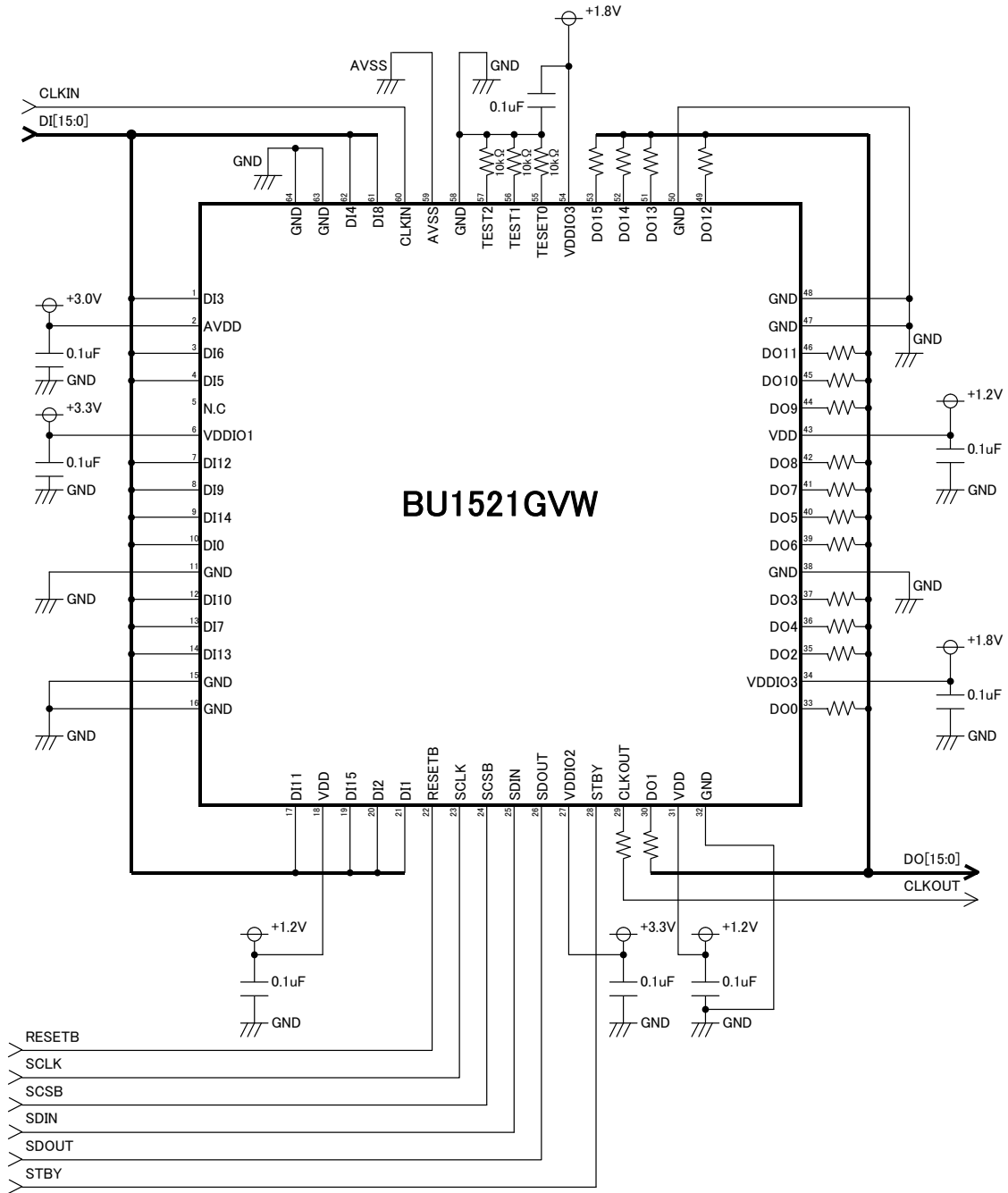

Note 1) Adjust the output damping resistance for CLKOUT and DO [15:0] with the line load.

Note 2) When the STBY pin is unused, pull it down with a 10 kΩ resistor.

Fig. 9 BU1521GVW typical application circuit

● I/O pin equivalent circuit diagram

Fig. 10 An I/O pin equivalent circuit diagram.

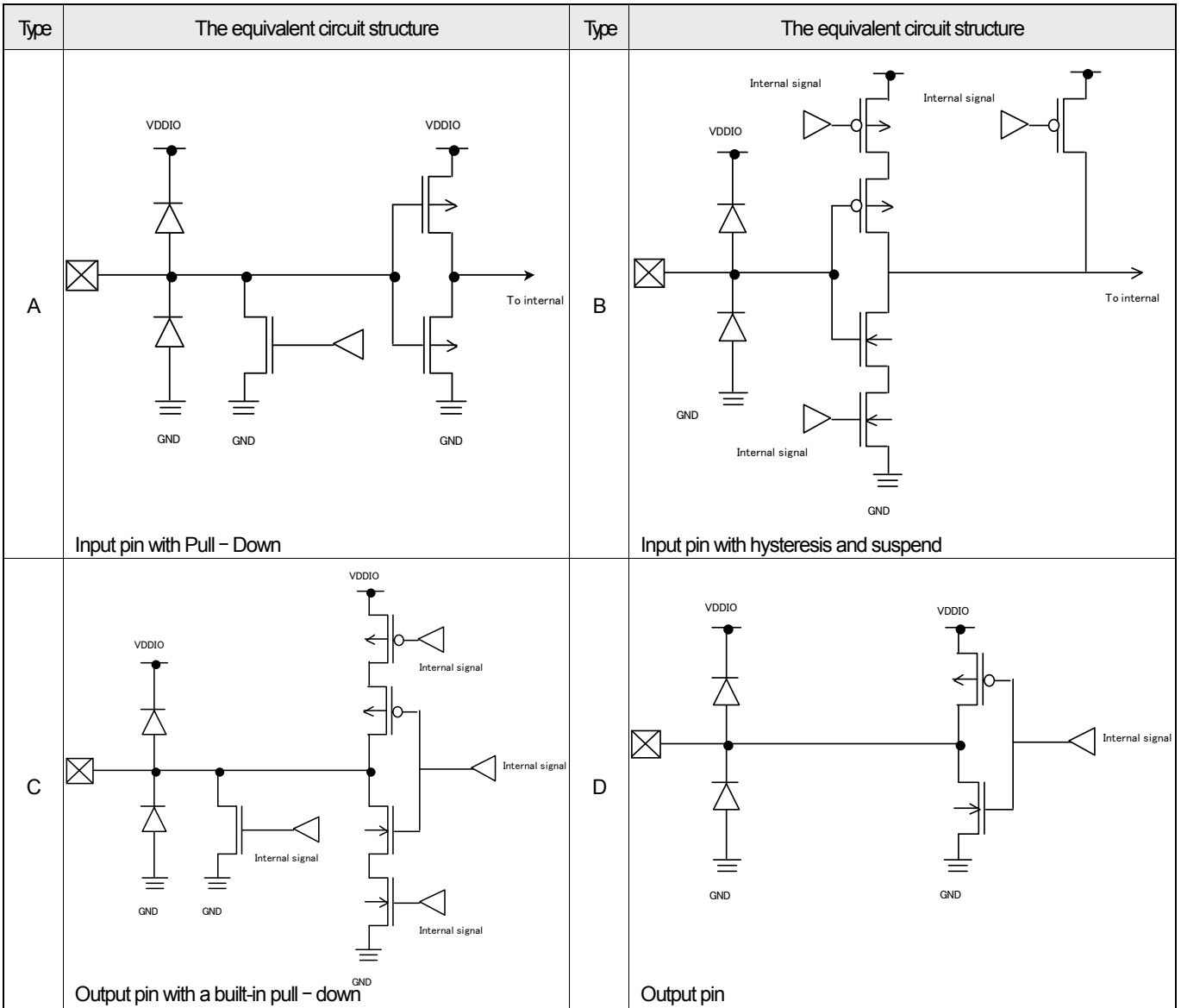

Fig. 10 BU1521GVW I/O pin equivalent circuit diagram

## ● Not for uses

- (1) Absolute Maximum Ratings  
An excess in the absolute maximum ratings, such as supply voltage, temperature range of operating conditions, etc., can break down devices, thus making impossible to identify breaking mode such as a short circuit or an open circuit. If any special mode exceeding the absolute maximum ratings is assumed, consideration should be given to take physical safety measures including the use of fuses, etc.
- (2) Operating conditions  
These conditions represent a range within which characteristics can be provided approximately as expected. The electrical characteristics are guaranteed under the conditions of each parameter.
- (3) Reverse connection of power supply connector  
The reverse connection of power supply connector can break down ICs. Take protective measures against the breakdown due to the reverse connection, such as mounting an external diode between the power supply and the IC's power supply terminal.
- (4) Power supply line  
Design PCB pattern to provide low impedance for the wiring between the power supply and the GND lines.  
In this regard, for the digital block power supply and the analog block power supply, even though these power supplies has the same level of potential, separate the power supply pattern for the digital block from that for the analog block, thus suppressing the diffraction of digital noises to the analog block power supply resulting from impedance common to the wiring patterns. For the GND line, give consideration to design the patterns in a similar manner.  
Furthermore, for all power supply terminals to ICs, mount a capacitor between the power supply and the GND terminal. At the same time, in order to use an electrolytic capacitor, thoroughly check to be sure the characteristics of the capacitor to be used present no problem including the occurrence of capacity dropout at a low temperature, thus determining the constant.
- (5) GND voltage  
Make setting of the potential of the GND terminal so that it will be maintained at the minimum in any operating state. Furthermore, check to be sure no terminals are at a potential lower than the GND voltage including an actual electric transient.
- (6) Short circuit between terminals and erroneous mounting  
In order to mount ICs on a set PCB, pay thorough attention to the direction and offset of the ICs. Erroneous mounting can break down the ICs. Furthermore, if a short circuit occurs due to foreign matters entering between terminals or between the terminal and the power supply or the GND terminal, the ICs can break down.
- (7) Operation in strong electromagnetic field  
Be noted that using ICs in the strong electromagnetic field can malfunction them.
- (8) Inspection with set PCB  
On the inspection with the set PCB, if a capacitor is connected to a low-impedance IC terminal, the IC can suffer stress. Therefore, be sure to discharge from the set PCB by each process. Furthermore, in order to mount or dismount the set PCB to/from the jig for the inspection process, be sure to turn OFF the power supply and then mount the set PCB to the jig. After the completion of the inspection, be sure to turn OFF the power supply and then dismount it from the jig. In addition, for protection against static electricity, establish a ground for the assembly process and pay thorough attention to the transportation and the storage of the set PCB.
- (9) Input terminals  
In terms of the construction of IC, parasitic elements are inevitably formed in relation to potential. The operation of the parasitic element can cause interference with circuit operation, thus resulting in a malfunction and then breakdown of the input terminal. Therefore, pay thorough attention not to handle the input terminals, such as to apply to the input terminals a voltage lower than the GND respectively, so that any parasitic element will operate. Furthermore, do not apply a voltage to the input terminals when no power supply voltage is applied to the IC. In addition, even if the power supply voltage is applied, apply to the input terminals a voltage lower than the power supply voltage or within the guaranteed value of electrical characteristics.
- (10) Ground wiring pattern  
If small-signal GND and large-current GND are provided, It will be recommended to separate the large-current GND pattern from the small-signal GND pattern and establish a single ground at the reference point of the set PCB so that resistance to the wiring pattern and voltage fluctuations due to a large current will cause no fluctuations in voltages of the small-signal GND. Pay attention not to cause fluctuations in the GND wiring pattern of external parts as well.
- (11) External capacitor  
In order to use a ceramic capacitor as the external capacitor, determine the constant with consideration given to a degradation in the nominal capacitance due to DC bias and changes in the capacitance due to temperature, etc.

● External Dimensional Drawing and Mark Drawing

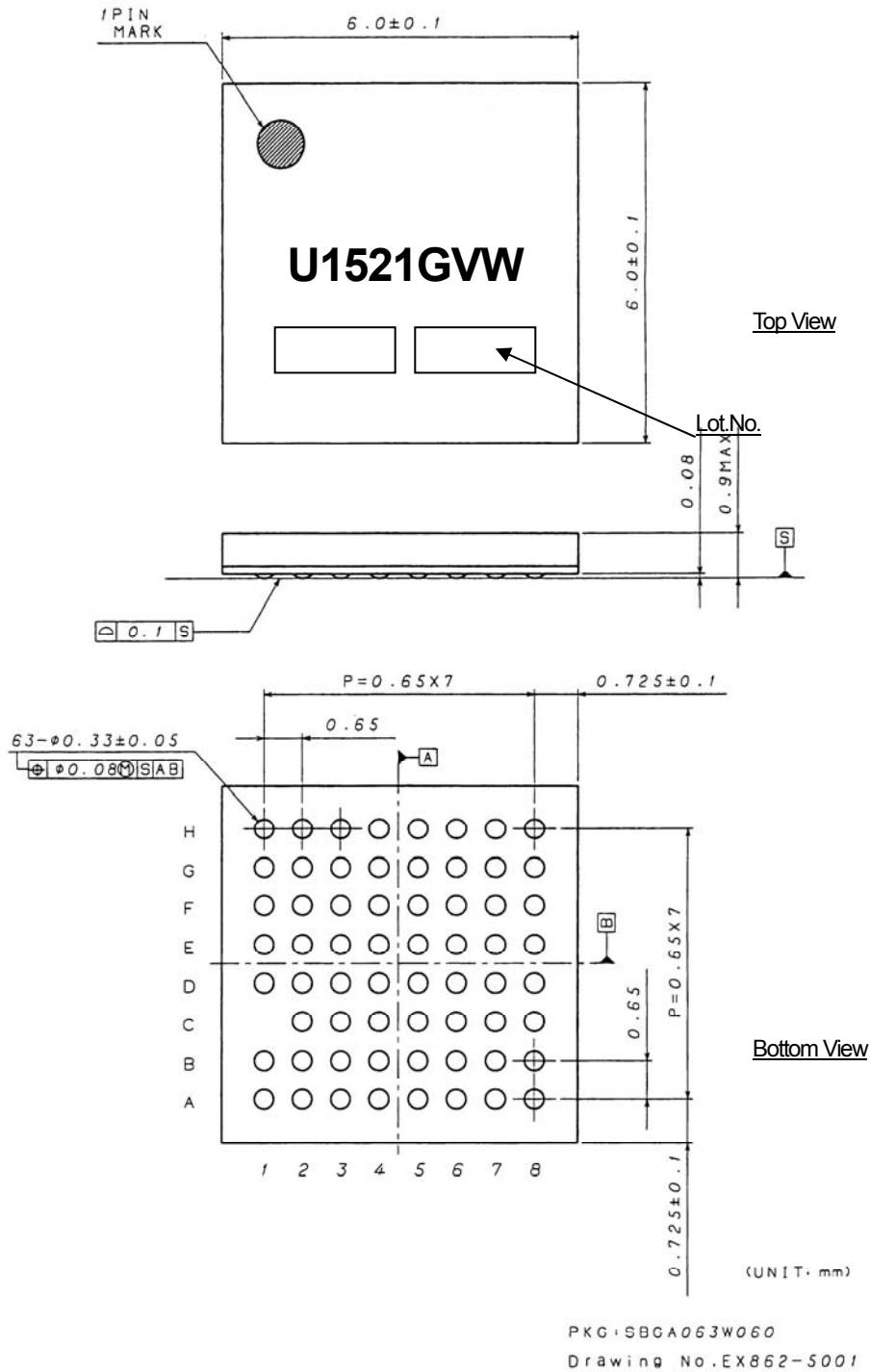

Fig. 11 BU1521GVW Package external view (SBGA063W060)

● Ordering part number

B	U
---	---

ROHM  
model name

1	5	2	1
---	---	---	---

Part No.

G	V	W
---	---	---

Package  
GVW: SBGA

E	2
---	---

Packaging and forming specification  
E2: Embossed tape and reel

SBGA063W060

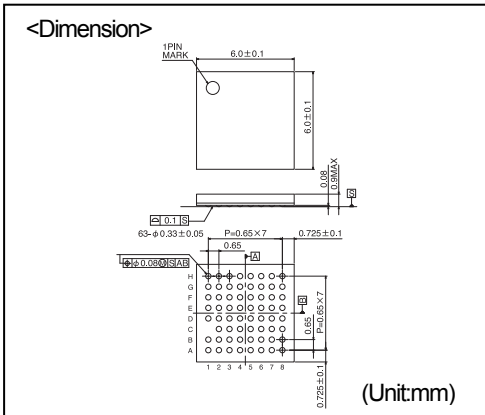

<Tape and Reel information>

Tape	Embossed carrier tape(with dry pack)
Quantity	2000pcs
Direction	E2 (The direction is the 1pin of product is at the upper left when you hold reel on the left hand and you pull out the tape on the right hand.)

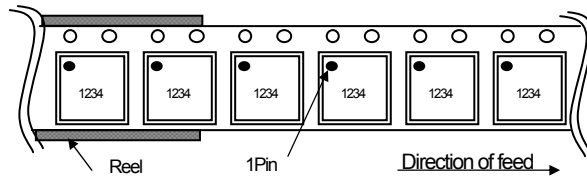

※When you order, please order in times the amount of package quantity.

## Notes

No copying or reproduction of this document, in part or in whole, is permitted without the consent of ROHM Co.,Ltd.

The content specified herein is subject to change for improvement without notice.

The content specified herein is for the purpose of introducing ROHM's products (hereinafter "Products"). If you wish to use any such Product, please be sure to refer to the specifications, which can be obtained from ROHM upon request.

Examples of application circuits, circuit constants and any other information contained herein illustrate the standard usage and operations of the Products. The peripheral conditions must be taken into account when designing circuits for mass production.

Great care was taken in ensuring the accuracy of the information specified in this document. However, should you incur any damage arising from any inaccuracy or misprint of such information, ROHM shall bear no responsibility for such damage.

The technical information specified herein is intended only to show the typical functions of and examples of application circuits for the Products. ROHM does not grant you, explicitly or implicitly, any license to use or exercise intellectual property or other rights held by ROHM and other parties. ROHM shall bear no responsibility whatsoever for any dispute arising from the use of such technical information.

The Products specified in this document are intended to be used with general-use electronic equipment or devices (such as audio visual equipment, office-automation equipment, communication devices, electronic appliances and amusement devices).

The Products specified in this document are not designed to be radiation tolerant.

While ROHM always makes efforts to enhance the quality and reliability of its Products, a Product may fail or malfunction for a variety of reasons.

Please be sure to implement in your equipment using the Products safety measures to guard against the possibility of physical injury, fire or any other damage caused in the event of the failure of any Product, such as derating, redundancy, fire control and fail-safe designs. ROHM shall bear no responsibility whatsoever for your use of any Product outside of the prescribed scope or not in accordance with the instruction manual.

The Products are not designed or manufactured to be used with any equipment, device or system which requires an extremely high level of reliability the failure or malfunction of which may result in a direct threat to human life or create a risk of human injury (such as a medical instrument, transportation equipment, aerospace machinery, nuclear-reactor controller, fuel-controller or other safety device). ROHM shall bear no responsibility in any way for use of any of the Products for the above special purposes. If a Product is intended to be used for any such special purpose, please contact a ROHM sales representative before purchasing.

If you intend to export or ship overseas any Product or technology specified herein that may be controlled under the Foreign Exchange and the Foreign Trade Law, you will be required to obtain a license or permit under the Law.



Thank you for your accessing to ROHM product informations.  
More detail product informations and catalogs are available, please contact us.

## ROHM Customer Support System

<http://www.rohm.com/contact/>





Компания «Life Electronics» занимается поставками электронных компонентов импортного и отечественного производства от производителей и со складов крупных дистрибьюторов Европы, Америки и Азии.

С конца 2013 года компания активно расширяет линейку поставок компонентов по направлению коаксиальный кабель, кварцевые генераторы и конденсаторы (керамические, пленочные, электролитические), за счёт заключения дистрибьюторских договоров

Мы предлагаем:

- Конкурентоспособные цены и скидки постоянным клиентам.
- Специальные условия для постоянных клиентов.
- Подбор аналогов.
- Поставку компонентов в любых объемах, удовлетворяющих вашим потребностям.
- Приемлемые сроки поставки, возможна ускоренная поставка.
- Доставку товара в любую точку России и стран СНГ.
- Комплексную поставку.
- Работу по проектам и поставку образцов.
- Формирование склада под заказчика.
- Сертификаты соответствия на поставляемую продукцию (по желанию клиента).
- Тестирование поставляемой продукции.
- Поставку компонентов, требующих военную и космическую приемку.
- Входной контроль качества.
- Наличие сертификата ISO.

В составе нашей компании организован Конструкторский отдел, призванный помогать разработчикам, и инженерам.

Конструкторский отдел помогает осуществить:

- Регистрацию проекта у производителя компонентов.
- Техническую поддержку проекта.
- Защиту от снятия компонента с производства.
- Оценку стоимости проекта по компонентам.
- Изготовление тестовой платы монтаж и пусконаладочные работы.



Тел: +7 (812) 336 43 04 (многоканальный)

Email: [org@lifeelectronics.ru](mailto:org@lifeelectronics.ru)