

LOC	DIST	REVISIONS					
GP	00	P	LTN	DESCRIPTION	DATE	DWN	APVD
		D		REVISED PER ECO-10-018054	04NOV2010	CJV	EJB
		E		REVISED PER ECO-12-005533	05APR2012	JY	AC
		F		REVISED PER ECO-14-016878	03DEC2014	RG	MC

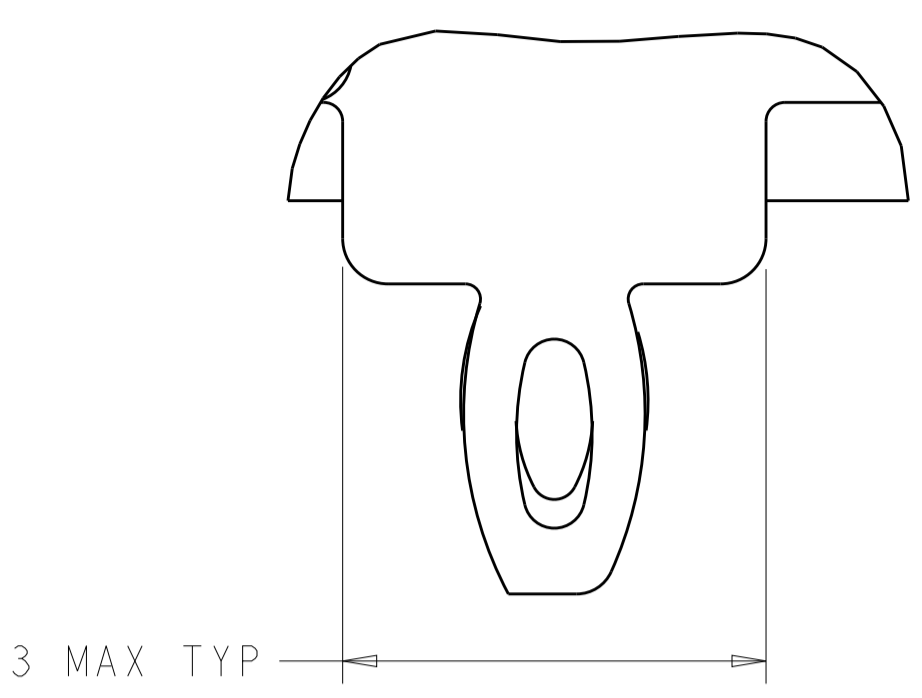

DETAIL S
 SCALE 20:1

- 1 MATERIALS:
 CAGE ASSEMBLY: NICKEL SILVER, 0.25 THICK
 HEAT SINK: ALUMINUM
 HEAT SINK CLIP: STAINLESS STEEL
 EMI SPRING: COPPER ALLOY
 FRONT FLANGE: ZINC ALLOY
 LIGHT PIPE: CLEAR POLYCARBONATE
- 2 PITCH BETWEEN PORTS OF ONE 1X3 CAGE ASSEMBLY.
- 3 SPACING BETWEEN CAGES ON THE SAME PC BOARD, TO BE SPECIFIED BY CUSTOMER, MUST COMPLY WITH MINIMUM DIMENSIONS SHOWN.
- 4 REFERENCE APPLICATION SPEC 114-13218 FOR RECOMMENDED DRILL HOLE DIAMETER AND PLATING THICKNESS.
- 5 DATUMS AND BASIC DIMENSIONS ESTABLISHED BY CUSTOMER.
- 6 DIMENSION C IS THE NOMINAL THICKNESS OF CUSTOMER SUPPLIED PC BOARD.
 SINGLE SIDED PC BOARD MIN THICKNESS = 1.45mm
 DOUBLE SIDED PC BOARD MIN THICKNESS = 2.2mm.
- 7 HEAT SINKS, LIGHT PIPES, AND CLIP SHIPPED ASSEMBLED TO CAGE ASSEMBLY. CAGE ASSEMBLY MAY BE PRESSED INTO THE PCB AS SHIPPED.
- 8 DATUM -A- IS TOP SURFACE OF PC BOARD.

- 9 DIMENSION APPLIES WITH MODULE INSERTED IN CAGE.
- 10 UNPLATED THRU HOLE.
- 11 MAXIMUM HEIGHT OF LED OFF BOARD: 0.9mm.
- 12. MATES WITH QSFP MSA COMPATIBLE TRANSCEIVER.
- 13 SURFACE TRACES PERMITTED WITHIN THIS AREA EXCEPT WHERE CAGE STANDOFFS, SHOWN IN DETAIL S, CONTACT PC BOARD.
- 14 BASELINE FOR THESE DIMENSIONS IS THE CENTER OF COMPLIANT PIN HOLE.
- 15 2D BARCODE AND DATE CODE (YYWWD) MARKED ON SIDE OF CAGE.
- 16 REFERENCE APP SPEC 114-13218 FOR GASKET THICKNESS CALCULATION.
- 17 FINISH:
 EMI SPRING: 2µm MINIMUM TIN
 FRONT FLANGE: 3µm MINIMUM TIN OVER 1.27µm MINIMUM NICKEL OVER 5.08µm MINIMUM COPPER
 HEATSINK: NICKEL
- 18 HEAT SINKS AND CLIPS SHIPPED ASSEMBLED TO CAGE ASSEMBLY. CAGE ASSEMBLY MAY BE PRESSED INTO THE PCB AS SHIPPED. LIGHT PIPES, SHIPPED UNATTACHED, MUST BE ASSEMBLED BY CUSTOMER AFTER THE CAGE IS SEATED IN THE PCB.

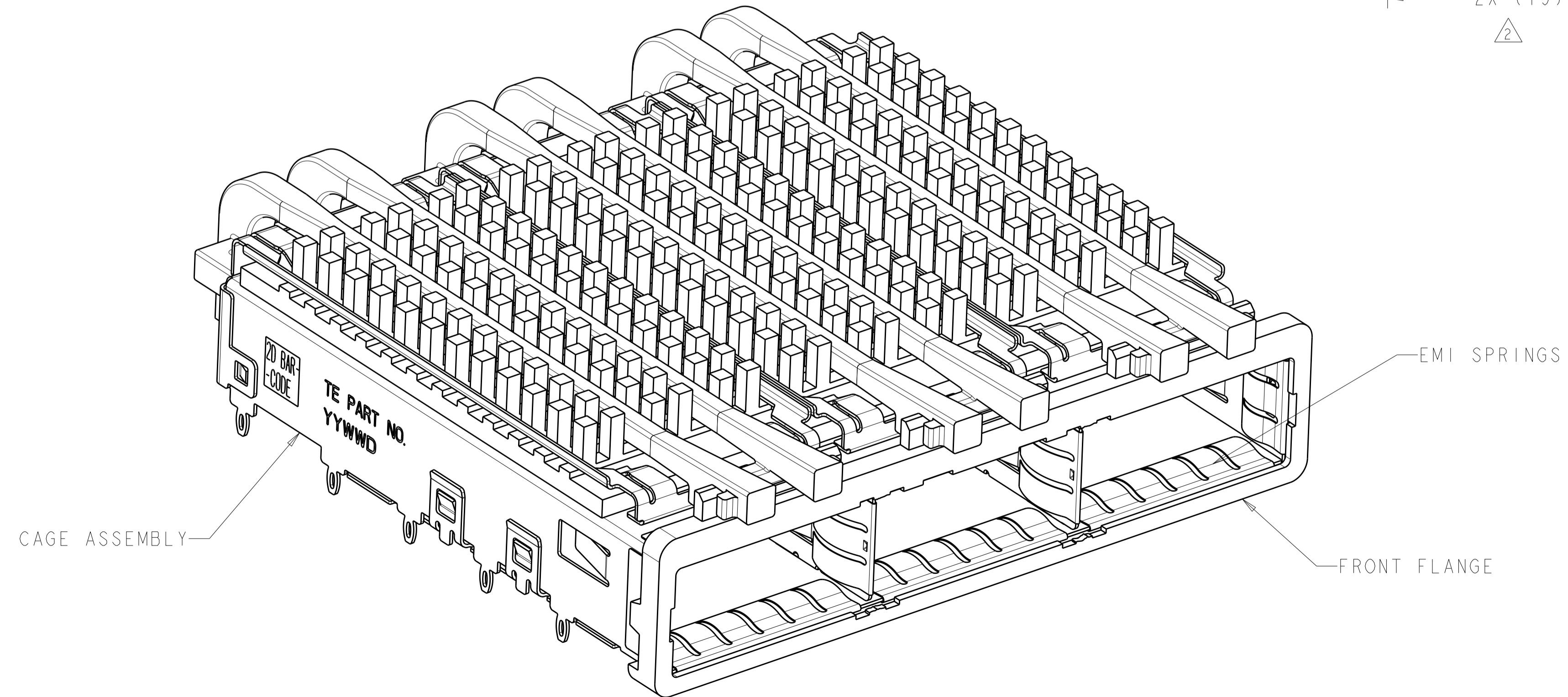
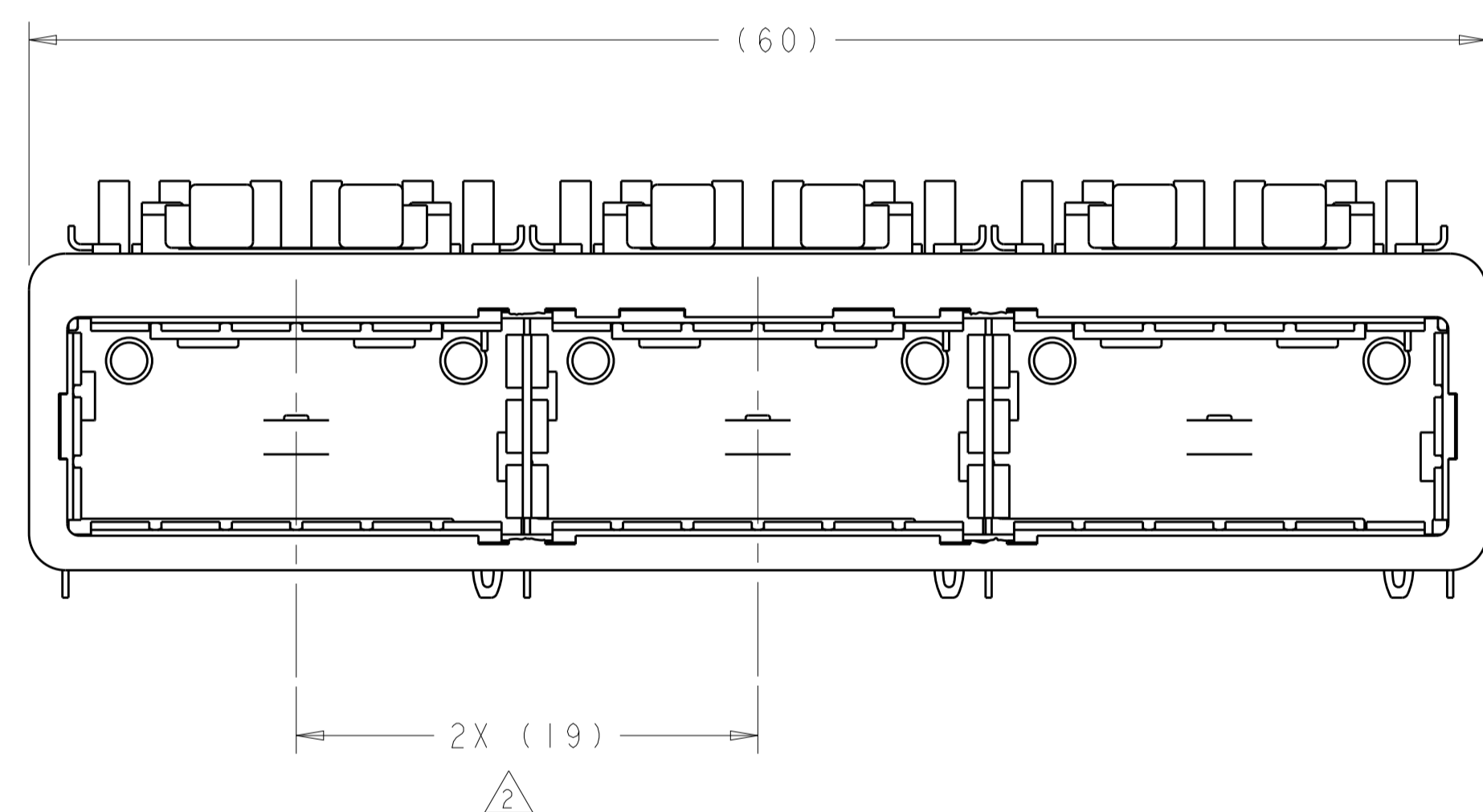
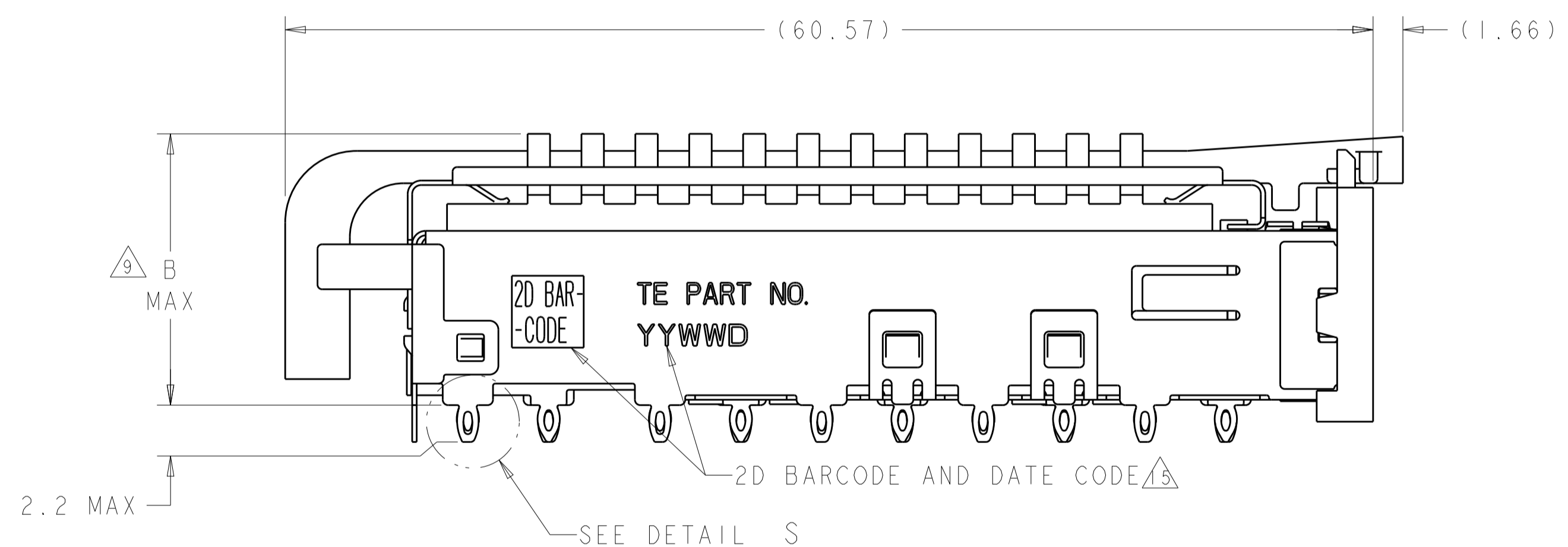

23.0	NETWORKING	2110412-3
16.0	SAN	2110412-2
13.7	PCI	2110412-1
B	HEAT SINK PROFILE	PART NUMBER

THIS DRAWING IS A CONTROLLED DOCUMENT.

DIMENSIONS:	TOLERANCES UNLESS OTHERWISE SPECIFIED:	DWN C. VALENTINE 28FEB2008	NAME 1X3 CAGE ASSEMBLY, BEHIND BEZEL, W/ SQUARE LIGHT PIPES AND HEAT SINKS QSFP
mm	0 PLC ±0.1	CHK J. PETERSON 28FEB2008	PRODUCT SPEC 108-2286
	1 PLC ±0.1	APVD J. PETERSON 28FEB2008	APPLICATION SPEC 114-13218
	2 PLC ±0.1		SIZE CAGE CODE DRAWING NO RESTRICTED TO
	3 PLC ±0.1		A100779C=2110412
	4 PLC ±0.1		SCALE 4:1 SHEET 1 OF 5 REV F
	ANGLES ±0.1		
MATERIAL	FINISH	WEIGHT	CUSTOMER DRAWING

LOC	DIST	REVISIONS			
P	LTN	DESCRIPTION	DATE	DMN	APVD
GP	00	SEE SHEET 1	-	-	-

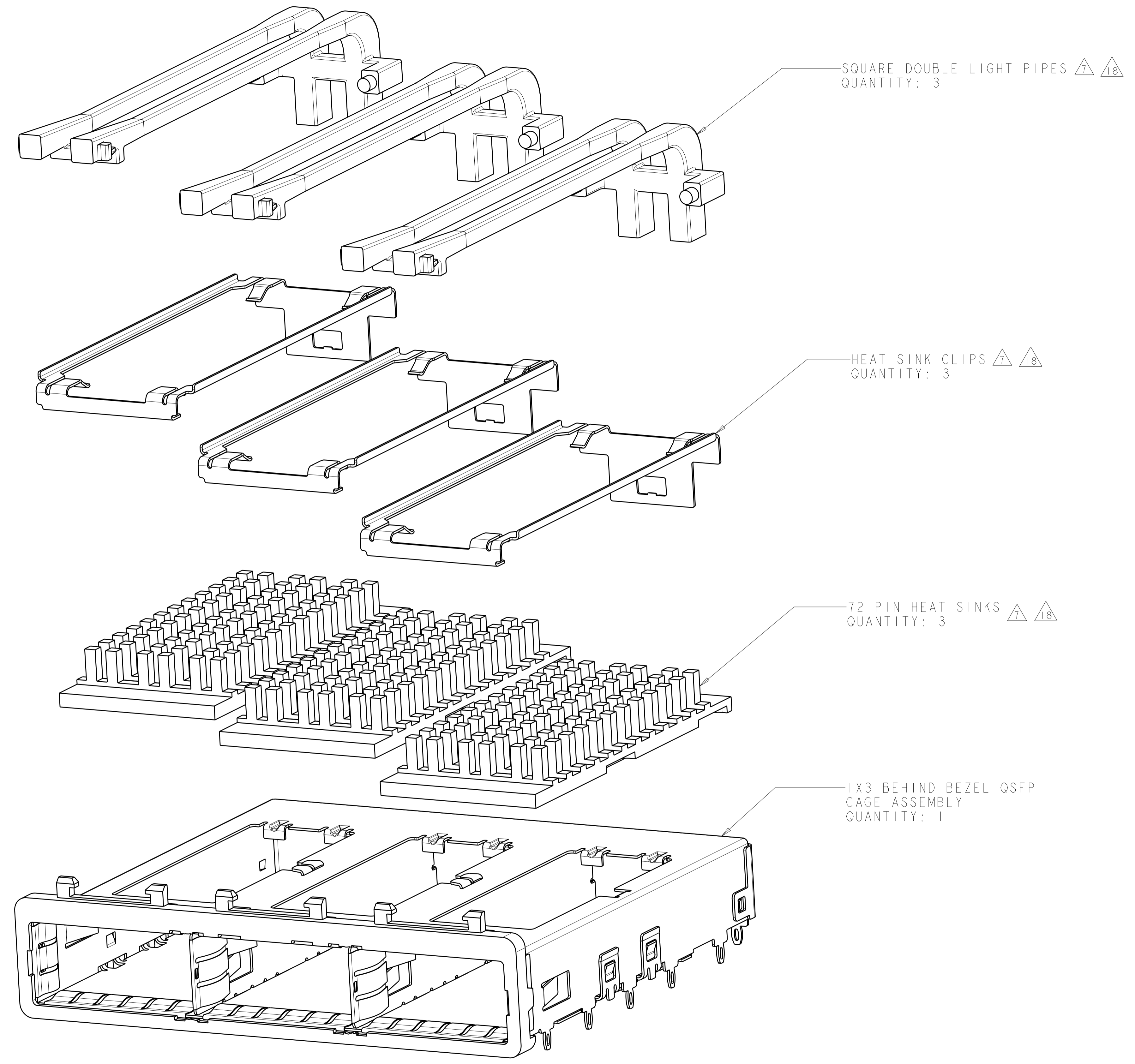

THIS DRAWING IS A CONTROLLED DOCUMENT.		DMN C. VALENTINE 28FEB2008	STE TE Connectivity
DIMENSIONS: mm		CHK J. PETERSON 28FEB2008	
TOLERANCES UNLESS OTHERWISE SPECIFIED:		APVD J. PETERSON 28FEB2008	NAME 1X3 CAGE ASSEMBLY, BEHIND BEZEL, W/ SQUARE LIGHT PIPES AND HEAT SINKS QSFP
0 PLC ± 1 PLC ±0.1 2 PLC ±0.1 3 PLC ± 4 PLC ±		PRODUCT SPEC 108-2286	RESTRICTED TO
ANGLES ±		APPLICATION SPEC 114-13218	SIZE CAGE CODE DRAWING NO A100779C=2110412
MATERIAL FINISH		WEIGHT	SCALE 4:1 SHEET 2 OF 5 REV F
		CUSTOMER DRAWING	

LOC		DIST		REVISIONS			
GP	00	P	LTN	DESCRIPTION	DATE	DMN	APVD
-	-	-	-	SEE SHEET 1	-	-	-

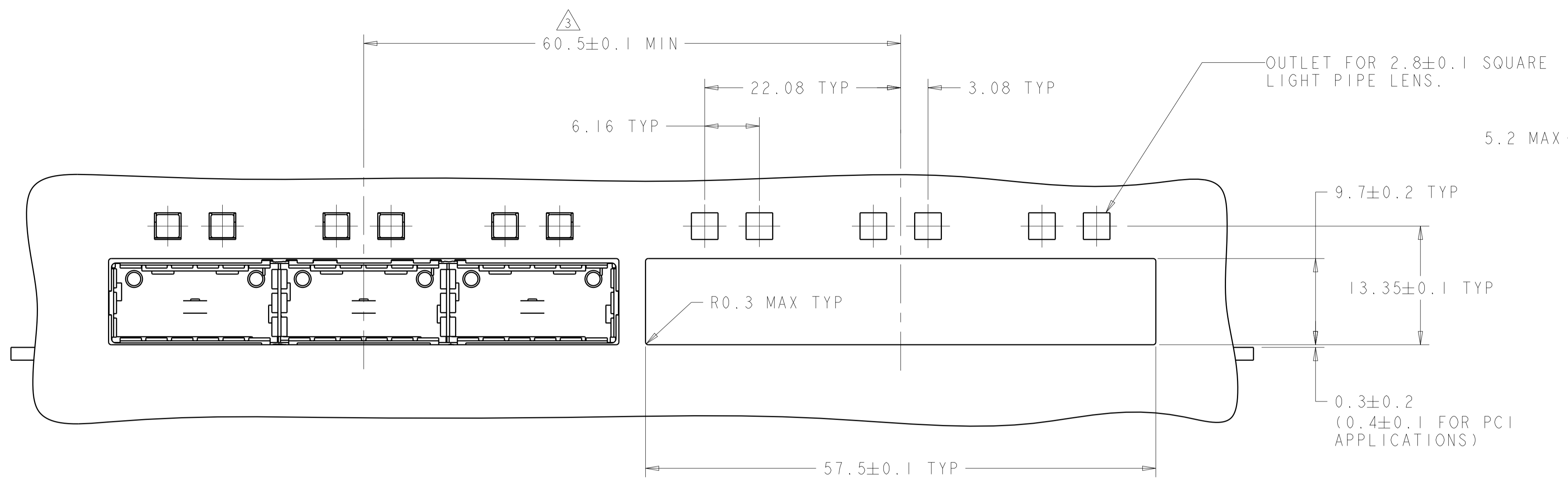

ONE SIDED CONFIGURATION
 SCALE 3:1

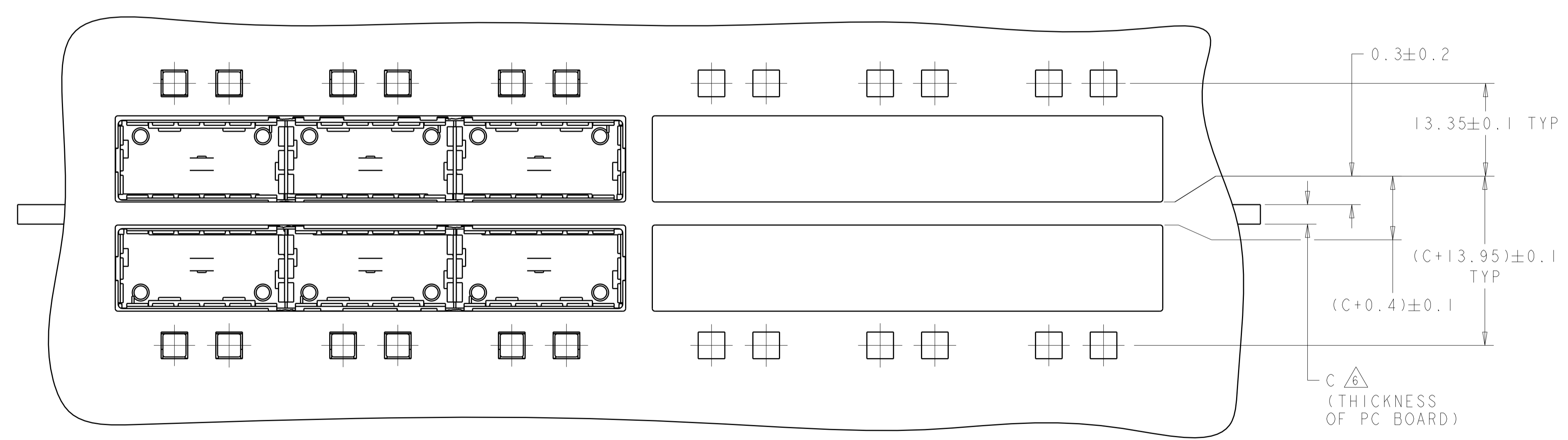
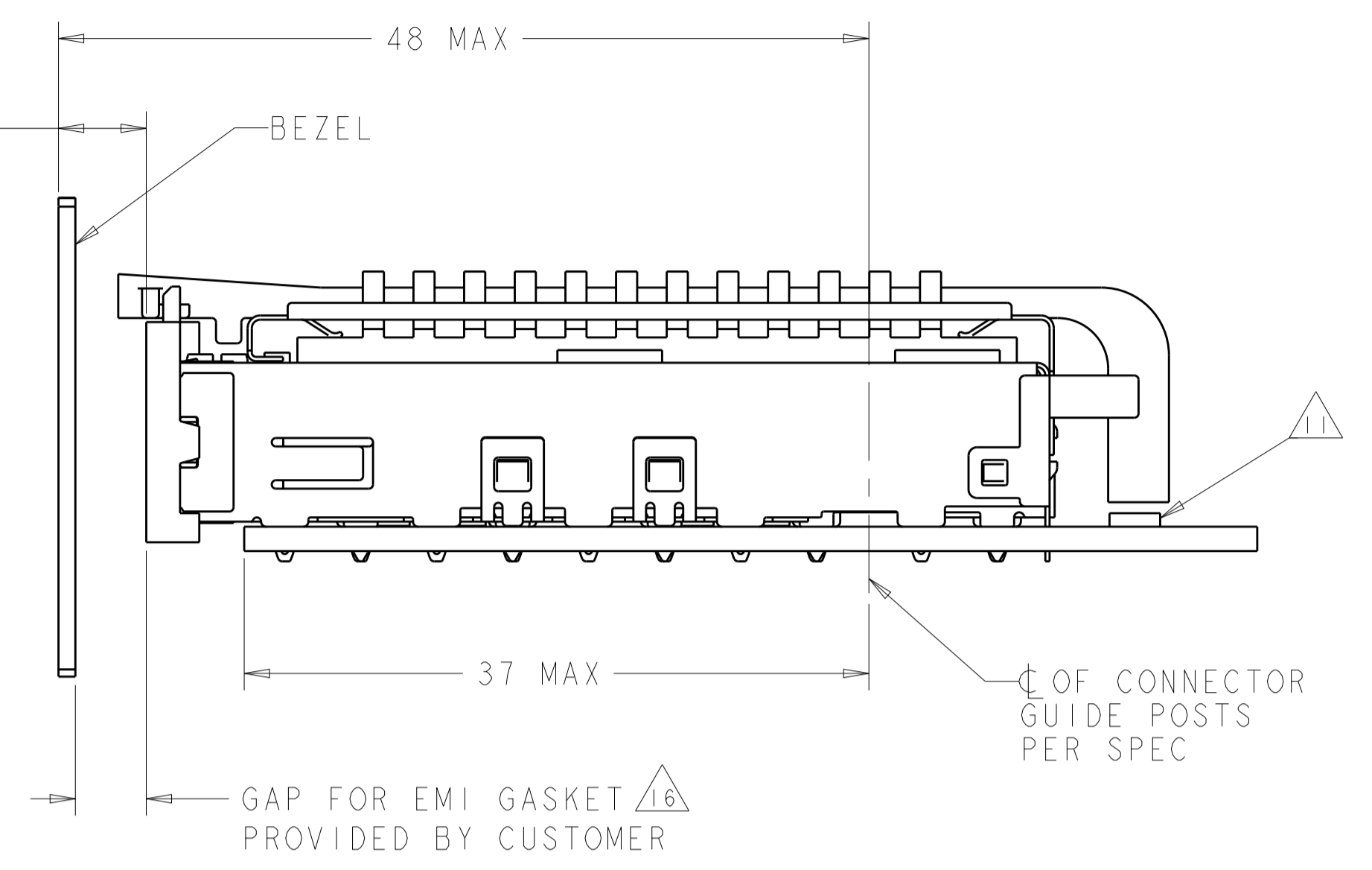

BELLY TO BELLY CONFIGURATION
 SIMILAR TO ONE SIDED
 EXCEPT WHERE NOTED
 SCALE 3:1

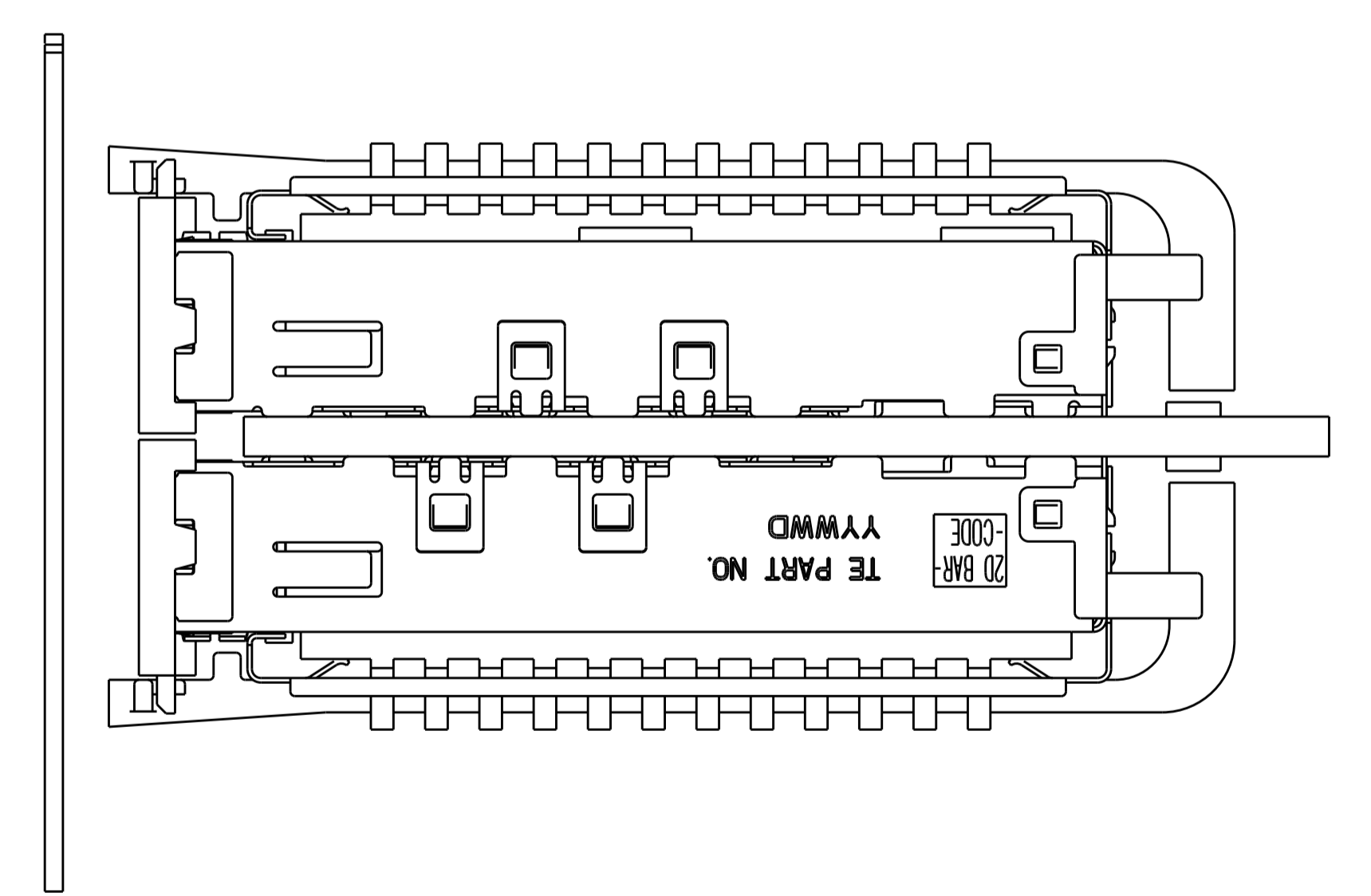

THIS DRAWING IS A CONTROLLED DOCUMENT.		DMN C. VALENTINE 28FEB2008	
DIMENSIONS:		CHK J. PETERSON 28FEB2008	
mm	TOLERANCES UNLESS OTHERWISE SPECIFIED:	APVD J. PETERSON 28FEB2008	NAME 1X3 CAGE ASSEMBLY, BEHIND BEZEL, W/ SQUARE LIGHT PIPES AND HEAT SINKS QSFP
	0 PLC ± 1 PLC ±0.1 2 PLC ±0.1 3 PLC ± 4 PLC ± ANGLES ± FINISH ±	PRODUCT SPEC 108-2286	SIZE A100779C=2110412
MATERIAL		APPLICATION SPEC 114-13218	RESTRICTED TO
		WEIGHT	CUSTOMER DRAWING
		SCALE 4:1	SHEET 3 OF 5
			REV F

LOC	DIST	REVISIONS					
GP	00	P	LTH	DESCRIPTION	DATE	DMN	APVD
-	-	-	-	SEE SHEET 1	-	-	-

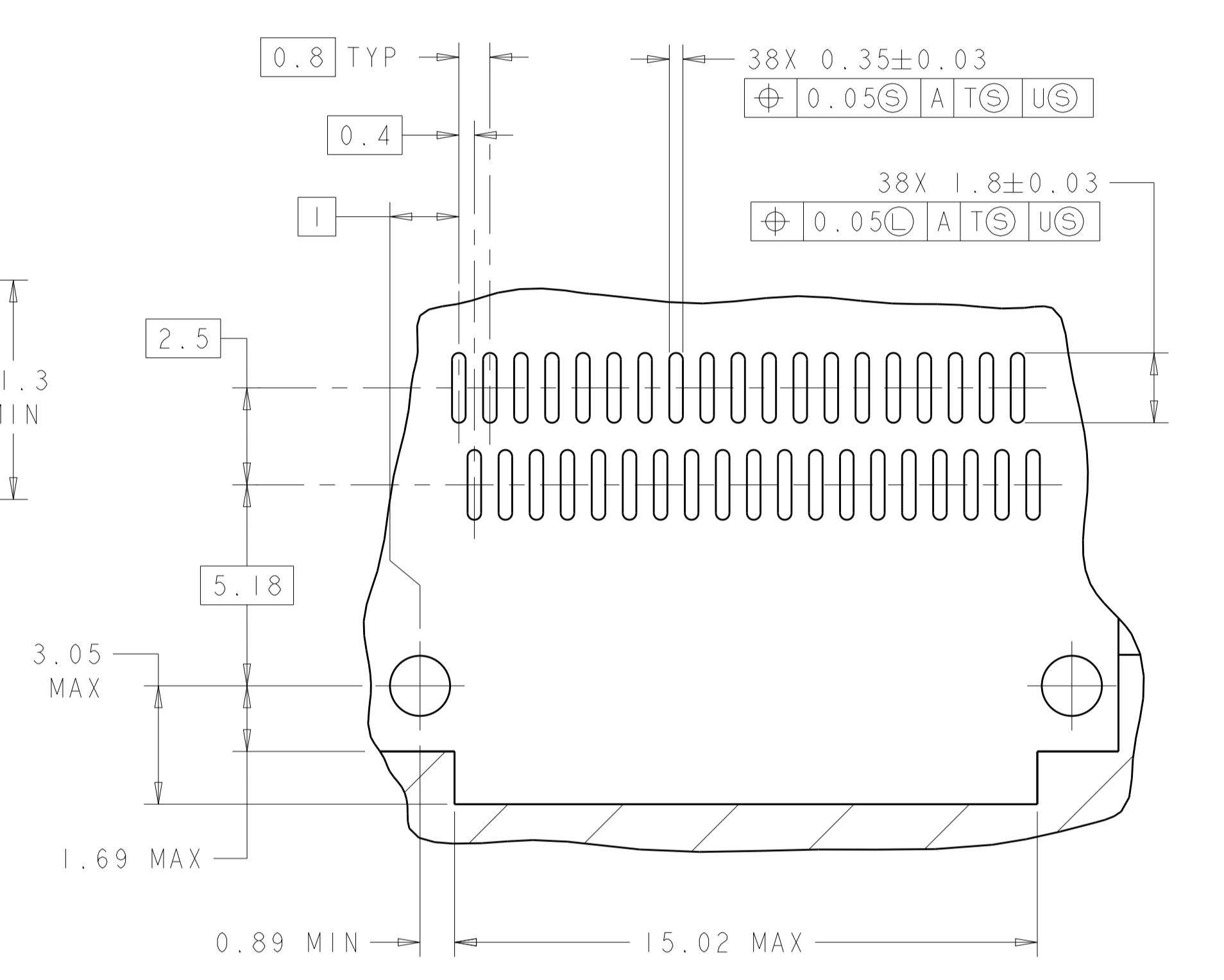
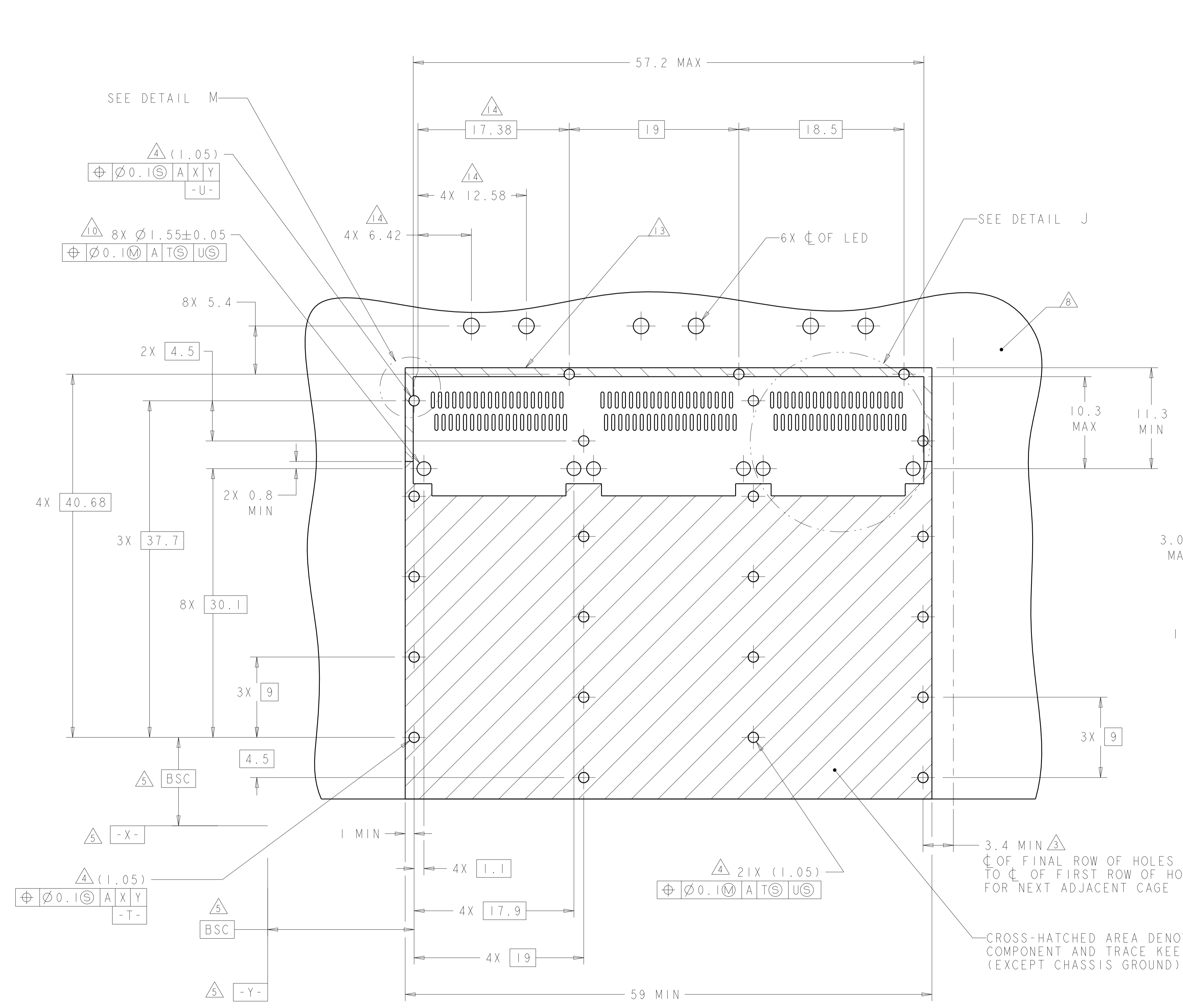

RECOMMENDED PC BOARD LAYOUT
 SINGLE SIDE MOUNT CONFIGURATION
 SCALE 4:1

THIS DRAWING IS A CONTROLLED DOCUMENT.		DMN C. VALENTINE 28FEB2008	TE Connectivity NAME 1X3 CAGE ASSEMBLY, BEHIND BEZEL, W/ SQUARE LIGHT PIPES AND HEAT SINKS QSFP
DIMENSIONS: mm		CHK J. PETERSON 28FEB2008	
TOLERANCES UNLESS OTHERWISE SPECIFIED:		APVD J. PETERSON 28FEB2008	PRODUCT SPEC 108-2286
0 PLC ± 1 PLC ±0.1 2 PLC ±0.1 3 PLC ± 4 PLC ± ANGLES ±		APPLICATION SPEC 114-13218	SIZE A100779C=2110412
MATERIAL		WEIGHT	RESTRICTED TO
FINISH		CUSTOMER DRAWING	SCALE 4:1 SHEET 4 OF 5 REV F

LOC	DIST	REVISIONS					
GP	00	P.	LTH	DESCRIPTION	DATE	DWN	APVD
		-		SEE SHEET 1	-	-	-

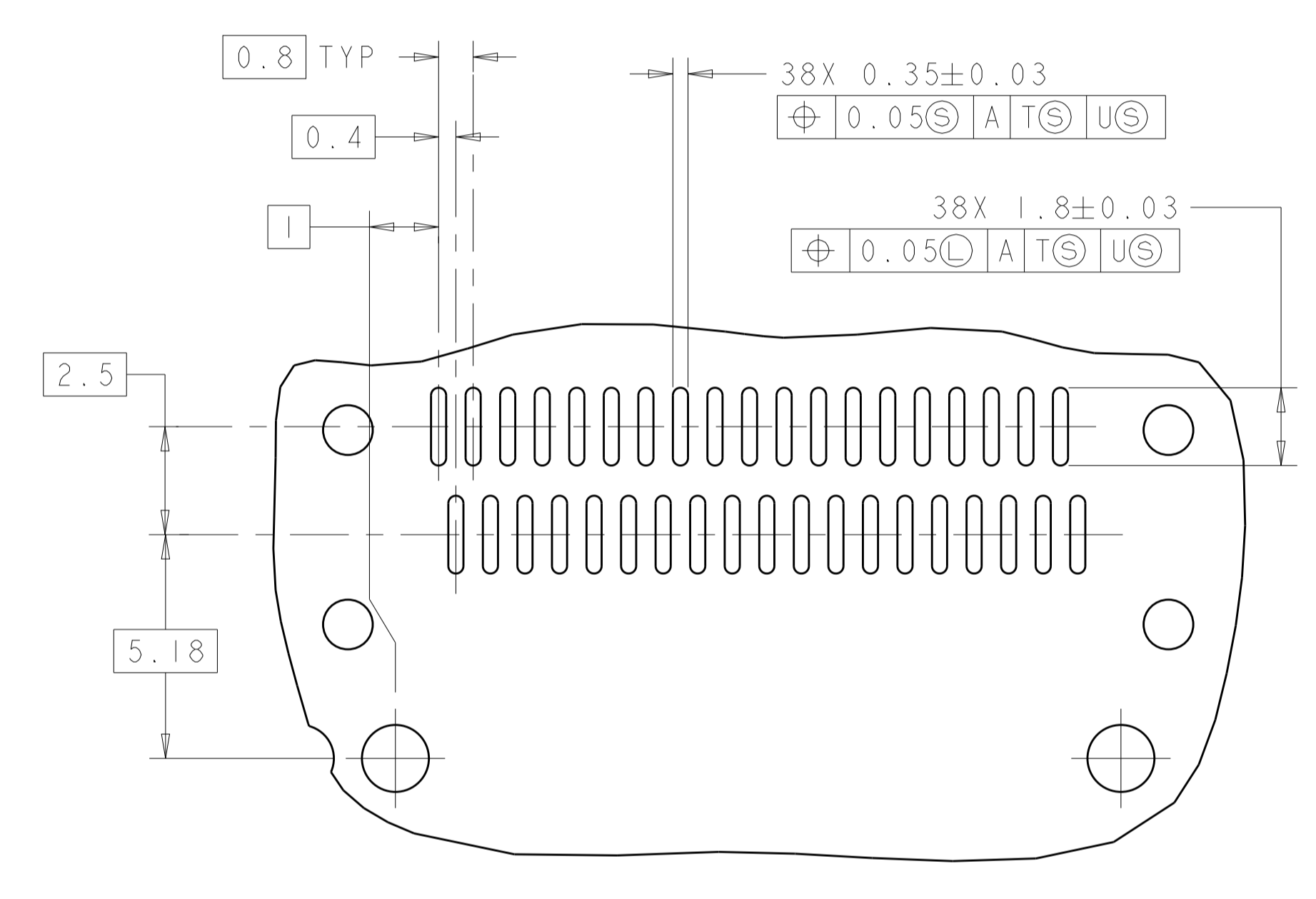
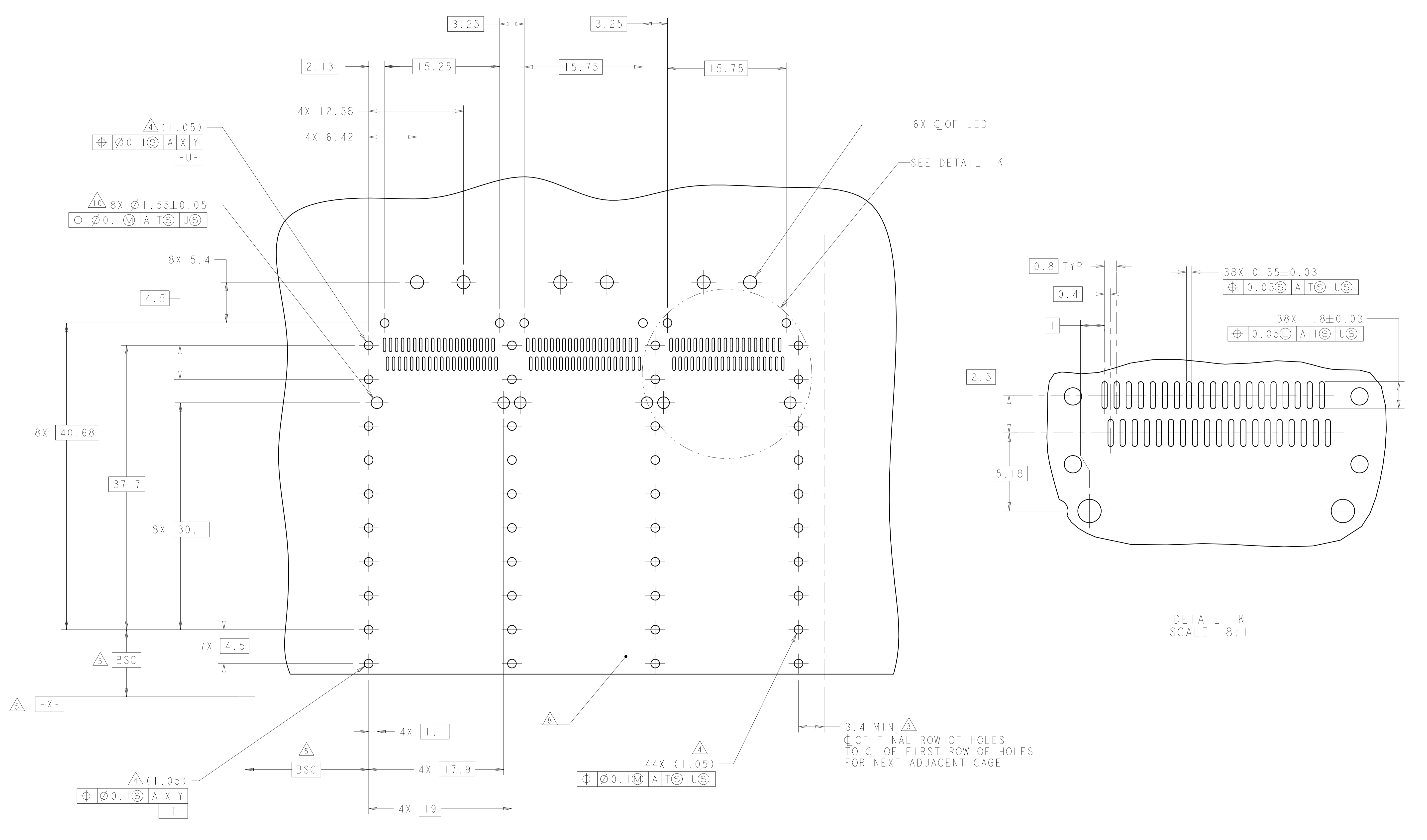

DETAIL K
SCALE 8:1

RECOMMENDED PC BOARD LAYOUT
 BELLY TO BELLY CONFIGURATION
 SEE SHEET 4 FOR COMPONENT AND TRACE KEEP-OUTS
 SCALE 4:1

THIS DRAWING IS A CONTROLLED DOCUMENT.		DWN C. VALENTINE 28FEB2008	TE Connectivity
DIMENSIONS: mm		CHK J. PETERSON 28FEB2008	
TOLERANCES UNLESS OTHERWISE SPECIFIED:		APVD J. PETERSON 28FEB2008	NAME 1X3 CAGE ASSEMBLY, BEHIND BEZEL, W/ SQUARE LIGHT PIPES AND HEAT SINKS QSFP
		PRODUCT SPEC 108-2286	RESTRICTED TO
MATERIAL		APPLICATION SPEC 114-13218	SIZE CAGE CODE DRAWING NO A100779C=2110412
FINISH		WEIGHT	SCALE 4:1 SHEET 5 OF 5 REV F
		CUSTOMER DRAWING	

Компания «Life Electronics» занимается поставками электронных компонентов импортного и отечественного производства от производителей и со складов крупных дистрибьюторов Европы, Америки и Азии.

С конца 2013 года компания активно расширяет линейку поставок компонентов по направлению коаксиальный кабель, кварцевые генераторы и конденсаторы (керамические, пленочные, электролитические), за счёт заключения дистрибьюторских договоров

Мы предлагаем:

- Конкурентоспособные цены и скидки постоянным клиентам.
- Специальные условия для постоянных клиентов.
- Подбор аналогов.
- Поставку компонентов в любых объемах, удовлетворяющих вашим потребностям.
- Приемлемые сроки поставки, возможна ускоренная поставка.
- Доставку товара в любую точку России и стран СНГ.
- Комплексную поставку.
- Работу по проектам и поставку образцов.
- Формирование склада под заказчика.
- Сертификаты соответствия на поставляемую продукцию (по желанию клиента).
- Тестирование поставляемой продукции.
- Поставку компонентов, требующих военную и космическую приемку.
- Входной контроль качества.
- Наличие сертификата ISO.

В составе нашей компании организован Конструкторский отдел, призванный помогать разработчикам, и инженерам.

Конструкторский отдел помогает осуществить:

- Регистрацию проекта у производителя компонентов.
- Техническую поддержку проекта.
- Защиту от снятия компонента с производства.
- Оценку стоимости проекта по компонентам.
- Изготовление тестовой платы монтаж и пусконаладочные работы.



Тел: +7 (812) 336 43 04 (многоканальный)

Email: org@lifeelectronics.ru