

MKW36A/35A/34A Data Sheet

An ultra low power, highly integrated Bluetooth® Low Energy 5.0 wireless microcontroller

MKW36A512VHT4
MKW36A512VFP4
MKW36A512VFT4
MKW35A512VFP4
MKW35A512VFT4
MKW34A512VFT4



48 LQFN
7x7 mm Pitch 0.5 mm



48 "Wettable" HVQFN
7x7 mm Pitch 0.5 mm



40 "Wettable" HVQFN
6x6 mm Pitch 0.5 mm

Multi-Standard Radio

- 2.4 GHz Bluetooth Low Energy (Bluetooth LE) version 5.0 compliant supporting up to 8 simultaneous hardware connections
- Generic FSK modulation
 - Data Rate: 250, 500 and 1000 kbps
 - Modulations: GFSK BT = 0.3, 0.5, and 0.7; FSK/MSK
 - Modulation Index: 0.32, 0.5, 0.7, and 1.0
- Typical Receiver Sensitivity (Bluetooth LE 1 Mbps) = -95 dBm
- Typical Receiver Sensitivity (250 kbps GFSK-BT=0.5, h=0.5) = -99 dBm
- Programmable Transmitter Output Power: -30 dBm to 5 dBm
- Low external component counts for low cost application
- On-chip balun with single ended bidirectional RF port

MCU and Memories

- 256 KB program flash memory plus 256 KB FlexNVM on KW36A/34A
- 8 KB FlexRAM supporting EEPROM emulation on KW36A/34A
- 512 KB program flash memory on KW35A
- Up to 48 MHz Arm® Cortex®-M0+ core
- On-chip 64 KB SRAM

System peripherals

- Nine MCU low-power modes to provide power optimization based on application requirements
- DC-DC Converter supporting Buck and Bypass operating modes
- Direct memory access (DMA) Controller
- Computer operating properly (COP) watchdog
- Serial wire debug (SWD) Interface and Micro Trace buffer
- Bit Manipulation Engine (BME)

Analog Modules

- 16-bit Analog-to-Digital Converter (ADC)
- 6-bit High Speed Analog Comparator (CMP)
- 1.2 V voltage reference (VREF)

Timers

- 16-bit low-power timer (LPTMR)
- 3 Timer/PWM Modules(TPM): One 4 channel TPM and two 2 channel TPMs
- Programmable Interrupt Timer (PIT)
- Real-Time Clock (RTC)

Communication interfaces

- 2 serial peripheral interface (SPI) modules
- 2 inter-integrated circuit (I2C) modules



Low Power Consumption

- Transceiver current (DC-DC buck mode, 3.6 V supply)
 - Typical Rx Current: 6.3 mA
 - Typical Tx current: 5.7 mA (0 dBm output)
- Low Power Mode (VLLS0) Current: 258 nA

Clocks

- 26 and 32 MHz supported for Bluetooth LE and Generic FSK modes
- 32.768 kHz Crystal Oscillator

Operating Characteristics

- Voltage range: 1.71 V to 3.6 V
- Ambient temperature range: -40 to 105 °C
- AEC Q100 Grade 2 Automotive Qualification

Human-machine interface

- General-purpose input/output

- Low Power UART (LPUART) module with LIN support (2x LPUART on KW36A)
- Carrier Modulator Timer (CMT)
- FlexCAN module (with CAN FD support up to 3.2 Mbps baudrate) on KW36A

Security

- AES-128 Hardware Accelerator (AESA)
- True Random Number Generator (TRNG)
- Advanced flash security on Program Flash
- 80-bit unique identification number per chip
- 40-bit unique media access control (MAC) sub-address
- LE Secure Connections

Orderable parts details

Device	Top Line Marking	Qualification	CAN FD	2 nd UART with LIN	FlexRAM	Package
MKW36A512VHT4	(F)M36A	Auto	Y	Y	Y	7X7 mm 48-pin LQFN
MKW36A512VFT4	MW36A512V4	Auto	Y	Y	Y	7X7 mm 48-pin "Wettable" HVQFN
MKW36A512VFP4	M36A9V4	Auto	Y	Y	Y	6X6 mm 40-pin "Wettable" HVQFN
MKW35A512VFT4	MW35A512V4	Auto	N	N	N	7X7 mm 48-pin "Wettable" HVQFN
MKW35A512VFP4	M35A9V4	Auto	N	N	N	6X6 mm 40-pin "Wettable" HVQFN
MKW34A512VFT4	MW34A512V4	Auto	N	N	Y	7X7 mm 48-pin "Wettable" HVQFN

Related Resources

Type	Description	Resource
Product Selector	The Product Selector lets you find the right Kinetis part for your design.	W-Series Product Selector
Fact Sheet	The Fact Sheet gives overview of the product key features and its uses.	KW36-35-34 Fact Sheet
Reference Manual	The Reference Manual contains a comprehensive description of the structure and function (operation) of a device.	MKW36A512RM ¹
Data Sheet	The Data Sheet includes electrical characteristics and signal connections.	This document.
Chip Errata	The chip mask set Errata provides additional or corrective information for a particular device mask set.	KINETIS_W_1N41U ¹

Table continues on the next page...

Related Resources (continued)

Type	Description	Resource
Package drawing	Package dimensions are provided in package drawings.	<ul style="list-style-type: none">• 40-pin "Wettable" HVQFN (6x6): 98ASA01025D¹• 48-pin LQFN (7x7): 98ASA00694D¹• 48-pin "Wettable" HVQFN (7x7): 98ASA01307D¹

1. To find the associated resource, go to <http://www.nxp.com> and perform a search using this term.

Table of Contents

1	Introduction.....	5	6.5	Peripheral operating requirements and behaviors.....	47
2	Feature Descriptions.....	6	6.5.1	Core modules.....	47
2.1	Block Diagram.....	6	6.5.2	System modules.....	48
2.2	Radio features.....	7	6.5.3	Clock modules.....	49
2.3	Microcontroller features.....	8	6.5.4	Memories and memory interfaces.....	53
2.4	System features.....	10	6.5.5	Security and integrity modules.....	55
2.5	Peripheral features.....	12	6.5.6	Analog.....	56
2.6	Security Features.....	16	6.5.7	Timers.....	63
3	Transceiver Description.....	17	6.5.8	Communication interfaces.....	63
3.1	Key Specifications.....	18	6.5.9	Human-machine interfaces (HMI).....	68
3.2	Channel Map Frequency Plans	18	6.6	DC-DC Converter Operating Requirements.....	68
3.2.1	Channel Plan for Bluetooth Low Energy.....	18	6.7	Ratings.....	71
3.2.2	Other Channel Plans	20	6.7.1	Thermal handling ratings.....	71
3.3	Transceiver Functions.....	20	6.7.2	Moisture handling ratings.....	71
4	Transceiver Electrical Characteristics.....	20	6.7.3	ESD handling ratings.....	71
4.1	Radio operating conditions.....	21	6.7.4	Voltage and current operating ratings.....	72
4.2	Receiver Feature Summary.....	21	7	Pin Diagrams and Pin Assignments.....	72
4.3	Transmit and PLL Feature Summary.....	23	7.1	KW36A Signal Multiplexing and Pin Assignments.....	72
5	System and Power Management.....	28	7.2	KW36A Pinouts.....	75
5.1	Power Management.....	28	7.3	KW35A Signal Multiplexing and Pin Assignments.....	78
5.1.1	DC-DC Converter.....	28	7.4	KW35A Pinouts.....	81
5.2	Modes of Operation.....	29	7.5	KW34A Signal Multiplexing and Pin Assignments.....	83
5.2.1	Power modes.....	29	7.6	KW34A Pinouts.....	86
6	KW36A/35A/34A Electrical Characteristics.....	31	7.7	Module Signal Description Tables.....	87
6.1	AC electrical characteristics.....	31	7.7.1	Core Modules.....	87
6.2	Nonswitching electrical specifications.....	32	7.7.2	Radio Modules.....	88
6.2.1	Voltage and current operating requirements.....	32	7.7.3	System Modules.....	89
6.2.2	LVD and POR operating requirements.....	33	7.7.4	Clock Modules.....	90
6.2.3	Voltage and current operating behaviors.....	34	7.7.5	Analog Modules.....	90
6.2.4	Power mode transition operating behaviors.....	35	7.7.6	Timer Modules.....	91
6.2.5	Power consumption operating behaviors.....	35	7.7.7	Communication Interfaces.....	92
6.2.6	Diagram: Typical IDD_RUN operating behavior.....	41	7.7.8	Human-Machine Interfaces(HMI).....	93
6.2.7	SoC Power Consumption.....	43	8	Package Information.....	94
6.2.8	Designing with radiated emissions in mind.....	44	8.1	Obtaining package dimensions.....	94
6.2.9	Capacitance attributes.....	44	9	Part identification.....	94
6.3	Switching electrical specifications.....	45	9.1	Description.....	94
6.3.1	Device clock specifications.....	45	9.2	Format.....	95
6.3.2	General switching specifications.....	45	9.3	Fields.....	95
6.4	Thermal specifications.....	46	9.4	Example.....	95
6.4.1	Thermal operating requirements.....	46	10	Revision History.....	96
6.4.2	Thermal attributes.....	47			

1 Introduction

The KW36A/35A/34A wireless microcontrollers (MCU), which includes the KW36A, KW35A, and KW34A families of devices, are highly integrated single-chip devices that enable Bluetooth Low Energy (Bluetooth LE) and Generic FSK connectivity for automotive embedded systems. To meet the stringent requirements of automotive applications, the KW36A/35A/34A is fully AEC Q100 Grade 2 Automotive Qualified. The target applications center on wirelessly bridging the embedded world with mobile devices to enhance the human interface experience, share embedded data between devices and the cloud and enable wireless firmware updates. Leading the automotive applications is the Digital Key, where a smartphone can be used by the owner as an alternative to the key FOB for unlocking and personalizing the driving experience. For a car sharing experience, the owner can provide selective, temporary authorization for access to the car allowing the authorized person to unlock, start and operate the car using their mobile device using Bluetooth LE.

The KW36A/35A/34A Wireless MCU integrates an Arm® Cortex®-M0+ CPU with up to 512 KB flash and 64 KB SRAM and a 2.4 GHz radio that supports Bluetooth LE 5.0 and Generic FSK modulations. The Bluetooth LE radio supports up to 8 simultaneous connections in any master/slave combination. The Medical Body Area Network (MBAN) frequencies from 2.36 to 2.4 GHz are also supported enabling wearable or implantable wireless medical devices.

The KW36A includes an integrated FlexCAN module enabling seamless integration into a cars in-vehicle CAN communication network. The FlexCAN module can support CAN's flexible data-rate (CAN FD) protocol for increased bandwidth and lower latency required by many automotive applications.

The KW36A/35A/34A devices can be used as a "BlackBox" modem in order to add Bluetooth LE or Generic FSK connectivity to an existing host MCU or MPU (microprocessor), or may be used as a standalone smart wireless sensor with embedded application where no host controller is required.

The RF circuit of the KW36A/35A/34A is optimized to require very few external components, achieving the smallest RF footprint possible on a printed circuit board. Extremely long battery life is achieved through the efficiency of code execution in the Cortex-M0+ CPU core and the multiple low power operating modes of the KW36A/35A/34A. For power critical applications, an integrated DC-DC converter enables operation from a single coin cell or Li-ion battery with a significant reduction of peak receive and transmit current consumption.

2 Feature Descriptions

This section provides a simplified block diagram and highlights the KW36A/35A/34A features.

2.1 Block Diagram



Figure 1. KW36 Detailed Block Diagram



Figure 2. KW35 Detailed Block Diagram

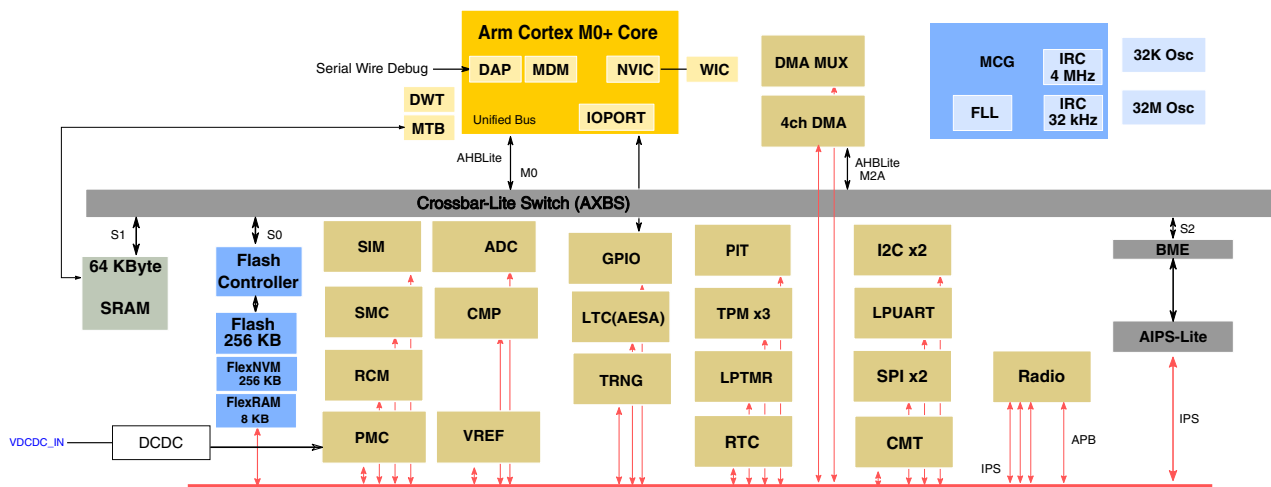

Figure 3. KW34 Detailed Block Diagram

2.2 Radio features

Operating frequencies:

- 2.4 GHz ISM band (2400-2483.5 MHz)
- Medical Body Area Network (MBAN) 2360-2400 MHz

Supported standards:

Feature Descriptions

- Bluetooth Low Energy Version 5.0 compliant radio
- Generic FSK modulation supporting data rates up to 1 Mbit/s
- Support for up to 8 simultaneous Bluetooth LE hardware connections in any master, slave combination
- Bluetooth LE Application Profiles

Receiver performance:

- Receive sensitivity of up to -95 dBm for Bluetooth LE
- Receive sensitivity of up to -99 dBm for a 250 kbit/s GFSK mode with a modulation index of 0.5. Receive sensitivity in Generic FSK modes depends on mode selection and data rate.

Other features:

- Programmable transmit output power from -30 dBm to $+5$ dBm
- 26 MHz and 32 MHz crystals supported for Bluetooth LE and Generic FSK modes
- Bluetooth Low Energy version 5.0 Link Layer hardware with 1 Mbit/s PHY support
- Hardware acceleration for Generic FSK packet processing
- Generic FSK modulation at 250, 500 and 1000 kbit/s
- Supports 8 simultaneous Bluetooth LE connections in any master/slave combination
- Enhanced Bluetooth LE automatic deep sleep modes (DSM) supporting Slave Latency
- Up to 26 devices supported by whitelist in hardware
- Up to 8 private resolvable addresses supported in hardware
- Supports DMA capture of IQ data with sampling rate of up to 2 MHz, when using a 32 MHz crystal
- Integrated on-chip balun
- Single ended bidirectional RF port shared by transmit and receive
- Low external component count
- Supports transceiver range extension using external PA and/or LNA

2.3 Microcontroller features

Arm Cortex-M0+ CPU

- Up to 48 MHz CPU

- As compared to Cortex-M0, the Cortex-M0+ uses an optimized 2-stage pipeline microarchitecture for reduced power consumption and improved architectural performance (cycles per instruction)
- Supports up to 32 interrupt request sources
- Binary compatible instruction set architecture with the Cortex-M0 core
- Thumb instruction set combines high code density with 32-bit performance
- Serial Wire Debug (SWD) reduces the number of pins required for debugging
- Micro Trace Buffer (MTB) provides lightweight program trace capabilities using system RAM as the destination memory

Nested Vectored Interrupt Controller (NVIC)

- 32 vectored interrupts, 4 programmable priority levels
- Includes a single non-maskable interrupt

Wake-up Interrupt Controller (WIC)

- Supports interrupt handling when system clocking is disabled in low-power modes
- Takes over and emulates the NVIC behavior when correctly primed by the NVIC on entry to very-deep-sleep
- A rudimentary interrupt masking system with no prioritization logic signals for wake-up as soon as a non-masked interrupt is detected

Debug Controller

- Two-wire Serial Wire Debug (SWD) interface
- Hardware breakpoint unit for 2 code addresses
- Hardware watchpoint unit for 2 data items
- Micro Trace Buffer for program tracing

On-Chip Memory

- Up to 512 KB Flash
 - KW36A/34A contains 256 KB program flash with ECC and 256 KB FlexNVM.
 - KW35A contains 512 KB program flash with ECC.
 - Flash implemented as two equal blocks each of 256 KB block. Code can execute or read from one block while the other block is being erased or programmed on KW35A only.
 - Firmware distribution protection. Program flash can be marked execute-only on a per-sector (8 KB) basis to prevent firmware contents from being read by third parties.

- 64 KB SRAM
- KW36A/34A contains 8 KB FlexRAM.
- KW35A contains 8 KB program acceleration RAM.
- Security circuitry to prevent unauthorized access to RAM and flash contents through the debugger

2.4 System features

Power Management Control Unit (PMC)

- Programmable power saving modes
- Available wake-up from power saving modes via internal and external sources
- Integrated Power-on Reset (POR)
- Integrated Low Voltage Detect (LVD) with reset (brownout) capability
- Selectable LVD trip points
- Programmable Low Voltage Warning (LVW) interrupt capability
- Individual peripheral clocks can be gated off to reduce current consumption
- Internal Buffered bandgap reference voltage
- Factory programmed trim for bandgap and LVD
- 1 kHz Low-power Oscillator (LPO)

DC-DC Converters

- Internal switched mode power supply supporting Buck and Bypass operating modes
- Buck operation supports external voltage sources of 2.1 V to 3.6 V
- When DC-DC is not used, the device supports an external voltage range of 1.5 V to 3.6 V (1.5 - 3.6 V on VDD_RF1, VDD_RF2, VDD_RF3 and VDD_1P5OUT_PMCIN pins. 1.71 - 3.6 V on VDD_0, VDD_1, and VDDA pins)
- An external inductor is required to support the Buck mode

Direct Memory Access (DMA) Controller

- All data movement via dual-address transfers: read from source, write to destination
- Programmable source and destination addresses and transfer size
- Support for enhanced addressing modes
- 4-channel implementation that performs complex data transfers with minimal intervention from a host processor
- Internal data buffer, used as temporary storage to support 16- and 32-byte transfers
- Connections to the crossbar switch for bus mastering the data movement

- Transfer Control Descriptor (TCD) organized to support two-deep, nested transfer operations
- 32-byte TCD stored in local memory for each channel
- An inner data transfer loop defined by a minor byte transfer count
- An outer data transfer loop defined by a major iteration count
- Channel activation via one of three methods:
 - Explicit software initiation
 - Initiation via a channel-to-channel linking mechanism for continuous transfers
 - Peripheral-paced hardware requests, one per channel
- Fixed-priority and round-robin channel arbitration
- Channel completion reported via optional interrupt requests
- One interrupt per channel, optionally asserted at completion of major iteration count
- Optional error terminations per channel and logically summed together to form one error interrupt to the interrupt controller
- Optional support for scatter/gather DMA processing
- Support for complex data structures

DMA Channel Multiplexer (DMA MUX)

- 4 independently selectable DMA channel routers
- 2 periodic trigger sources available
- Each channel router can be assigned to 1 of the peripheral DMA sources

COP Watchdog Module

- Independent clock source input (independent from CPU/bus clock)
- Choice between two clock sources
 - LPO oscillator
 - Bus clock

System Clocks

- Both 26 MHz and 32 MHz crystal reference oscillator supported for Bluetooth LE and Generic FSK modes
- MCU can derive its clock either from the crystal reference oscillator or the Frequency-locked Loop (FLL)¹
- 32.768 kHz crystal reference oscillator used to maintain precise Bluetooth Low Energy timing in low-power modes
- Multipurpose Clock Generator (MCG)

1. Clock options can have restrictions based on the chosen SoC configuration.

Feature Descriptions

- Internal reference clocks — Can be used as a clock source for other on-chip peripherals
 - On-chip RC oscillator range of 31.25 kHz to 39.0625 kHz with 2% accuracy across full temperature range
 - On-chip 4 MHz oscillator with 5% accuracy across full temperature range
- Frequency-locked Loop (FLL) controlled by internal or external reference
 - 20 MHz to 48 MHz FLL output

Unique Identifiers

- 80-bit Unique ID represents a unique identifier for each chip
- 40-bit unique Media Access Control (MAC) address, which can be used to build a unique 48-bit Bluetooth Low Energy MAC address

2.5 Peripheral features

16-bit Analog-to-Digital Converter (ADC)

- Linear successive approximation algorithm with 16-bit resolution
- Output formatted in differential-ended 16-, 13-, 11-, and 9-bit mode
- Output formatted in single-ended 16-, 12-, 10-, and 8-bit mode
- Single or continuous conversion
- Configurable sample time and conversion speed/power
- Conversion rates in 16-bit mode with no averaging up to ~500Ksamples/sec
- Input clock selection
- Operation in low-power modes for lower noise operation
- Asynchronous clock source for lower noise operation
- Selectable asynchronous hardware conversion trigger
- Automatic compare with interrupt for less-than, or greater than, or equal to programmable value
- Temperature sensor
- Battery voltage measurement
- Hardware average function
- Selectable voltage reference
- Self-calibration mode

High-Speed Analog Comparator (CMP)

- 6-bit DAC programmable reference generator output
- Up to eight selectable comparator inputs; each input can be compared with any input by any polarity sequence

- Selectable interrupt on rising edge, falling edge, or either rising or falling edges of comparator output
- Two performance modes:
 - Shorter propagation delay at the expense of higher power
 - Low-power, with longer propagation delay
- Operational in all MCU power modes except VLLS0 mode

Voltage Reference(VREF1)

- Programmable trim register with 0.5 mV steps, automatically loaded with factory trimmed value upon reset
- Programmable buffer mode selection:
 - Off
 - Bandgap enabled/standby (output buffer disabled)
 - High-power buffer mode (output buffer enabled)
- 1.2 V output at room temperature
- VREF_OUT output signal

Low-power Timer (LPTMR)

- One channel
- Operation as timer or pulse counter
- Selectable clock for prescaler/glitch filter
 - 1 kHz internal LPO
 - External low-power crystal oscillator
 - Internal reference clock
- Configurable glitch filter or prescaler
- Interrupt generated on timer compare
- Hardware trigger generated on timer compare
- Functional in all power modes

Timer/PWM (TPM)

- TPM0: 4 channels, TPM1 and TPM2: 2 channels each
- Selectable source clock
- Programmable prescaler
- 16-bit counter supporting free-running or initial/final value, and counting is up or up-down
- Input capture, output compare, and edge-aligned and center-aligned PWM modes
- Input capture and output compare modes
- Generation of hardware triggers
- TPM1 and TPM2: Quadrature decoder with input filters
- Global time base mode shares single time base across multiple TPM instances

Programmable Interrupt Timer (PIT)

- Up to 2 interrupt timers for triggering ADC conversions
- 32-bit counter resolution
- Clocked by bus clock frequency

Real-Time Clock (RTC)

- 32-bit seconds counter with 32-bit alarm
 - Can be invalidated on detection of tamper detect
- 16-bit prescaler with compensation
- Register write protection
 - Hard Lock requires MCU POR to enable write access
 - Soft lock requires POR or software reset to enable write/read access
- Capable of waking up the system from low-power modes

Inter-Integrated Circuit (I²C)

- Two channels
- Compatible with I2C bus standard and SMBus Specification Version 2 features
- Up to 400 kHz operation
- Multi-master operation
- Software programmable for one of 64 different serial clock frequencies
- Programmable slave address and glitch input filter
- Interrupt driven byte-by-byte data transfer
- Arbitration lost interrupt with automatic mode switching from master to slave
- Calling address identification interrupt
- Bus busy detection broadcast and 10-bit address extension
- Address matching causes wake-up when processor is in low-power mode

LPUART

- One channel (2 channels on KW36A)
- Full-duplex operation
- Standard mark/space Non-return-to-zero (NRZ) format
- 13-bit baud rate selection with fractional divide of 32
- Programmable 8-bit or 9-bit data format
- Programmable 1 or 2 stop bits
- Separately enabled transmitter and receiver
- Programmable transmitter output polarity
- Programmable receive input polarity
- 13-bit break character option
- 11-bit break character detection option

- Two receiver wake-up methods:
 - Idle line wake-up
 - Address mark wake-up
- Address match feature in receiver to reduce address mark wake-up ISR overhead
- Interrupt or DMA driven operation
- Receiver framing error detection
- Hardware parity generation and checking
- Configurable oversampling ratio to support from 1/4 to 1/32 bit-time noise detection
- Operation in low-power modes
- Hardware Flow Control RTS\CTS
- Functional in Stop/VLPS modes
- Break detect supporting LIN

Serial Peripheral Interface (SPI)

- Two independent SPI channels
- Master and slave mode
- Full-duplex, three-wire synchronous transfers
- Programmable transmit bit rate
- Double-buffered transmit and receive data registers
- Serial clock phase and polarity options
- Slave select output
- Control of SPI operation during wait mode
- Selectable MSB-first or LSB-first shifting
- Support for both transmit and receive by DMA

Carrier Modulator Timer (CMT)

- Four modes of operation
 - Time; with independent control of high and low times
 - Baseband
 - Frequency shift key (FSK)
 - Direct software control of CMT_IRO signal
- Extended space operation in time, baseband, and FSK modes
- Selectable input clock divider
- Interrupt on end of cycle
- Ability to disable CMT_IRO signal and use as timer interrupt

General Purpose Input/Output (GPIO)

- Hysteresis and configurable pull up device on all input pins
- Independent pin value register to read logic level on digital pin

Feature Descriptions

- All GPIO pins can generate IRQ and wake-up events
- Configurable drive strength on some output pins
- GPIO can be configured to function as a interrupt driven keyboard scanning matrix
 - In the 48-pin package there are a total of 25 digital pins
 - In the 40-pin package there are a total of 18 digital pins

FlexCAN (for KW36A only)

- Full implementation of the CAN with Flexible Data Rate (CAN FD) protocol specification and CAN protocol specification, Version 2.0 B
- Flexible Message Buffers (MBs); there are total 32 MBs of 8 bytes data length each, configurable as Rx or Tx, all supporting standard and extended messages
- Programmable clock source to the CAN Protocol Interface, either peripheral clock or oscillator clock
- Capability to select priority between mailboxes and Rx FIFO during matching process
- Powerful Rx FIFO ID filtering, capable of matching incoming IDs against either 128 extended, 256 standard, or 512 partial (8 bit) IDs, with up to 32 individual masking capability

2.6 Security Features

Advanced Encryption Standard Accelerator(AES-128 Accelerator)

The Advanced Encryption Standard Accelerator (AESA) module is a standalone hardware coprocessor capable of accelerating the 128-bit advanced encryption standard (AES) cryptographic algorithms.

The AESA engine supports the following cryptographic features.

LTC includes the following features:

- Cryptographic authentication
 - Message Authentication Codes (MAC)
 - Cipher-based MAC (AES-CMAC)
 - Extended cipher block chaining message authentication code (AES-XCBC-MAC)
 - Auto padding
 - Integrity Check Value(ICV) checking
- Authenticated encryption algorithms
 - Counter with CBC-MAC (AES-CCM)
- Symmetric key block ciphers

- AES (128-bit keys)
- Cipher modes:
 - AES-128 modes
 - Electronic Codebook (ECB)
 - Cipher Block Chaining (CBC)
 - Counter (CTR)
- Secure scan

True Random Number Generator (TRNG)

True Random Number Generator (TRNG) is a hardware accelerator module that constitutes a high-quality entropy source.

- TRNG generates a 512-bit (4x 128-bit) entropy as needed by an entropy-consuming module, such as a deterministic random number generator.
- TRNG output can be read and used by a deterministic pseudo-random number generator (PRNG) implemented in software.
- TRNG-PRNG combination achieves NIST-compliant true randomness and cryptographic-strength random numbers using the TRNG output as the entropy source.
- A fully FIPS 180 compliant solution can be realized using the TRNG together with a FIPS-compliant deterministic random number generator and the SoC-level security.

Flash Memory Protection

The on-chip flash memory controller enables the following useful features:

- Program flash protection scheme prevents accidental program or erase of stored data.
- Automated, built-in, program and erase algorithms with verify.
- Read access to one program flash block is possible while programming or erasing data in the other program flash block.

3 Transceiver Description

- Direct Conversion Receiver (Zero IF)
- Constant Envelope Transmitter
- 2.36 GHz to 2.483 GHz PLL Range
- Low Transmit and Receive Current Consumption
- Low BOM

3.1 Key Specifications

KW36A/35A/34A meets or exceeds all Bluetooth Low Energy version 5.0 performance specifications. The key specifications for the KW36A/35A/34A are:

Frequency Band:

- ISM Band: 2400 to 2483.5 MHz
- MBAN Band: 2360 to 2400 MHz

Bluetooth Low Energy version 5.0 modulation scheme:

- Symbol rate: 1000 kbit/s
- Modulation: GFSK
- Receiver sensitivity: -95 dBm, typical
- Programmable transmitter output power: -30 dBm to +5 dBm

Generic FSK modulation scheme:

- Symbol rate: 250, 500 and 1000 kbit/s
- Modulation(s): GFSK (modulation index = 0.32, 0.5, 0.7 and 1.0, BT = 0.3, 0.5, and 0.7), FSK and MSK
- Receiver Sensitivity: Mode and data rate dependent. -99 dBm typical for GFSK (r=250 kbit/s, BT = 0.5, h = 0.5)

3.2 Channel Map Frequency Plans

3.2.1 Channel Plan for Bluetooth Low Energy

This section describes the frequency plan / channels associated with 2.4 GHz ISM and MBAN bands for Bluetooth Low Energy.

2.4 GHz ISM Channel numbering:

- $F_c = 2402 + k * 2$ MHz, $k=0, \dots, 39$.

MBAN Channel numbering:

- $F_c = 2360 + k$ in MHz, for $k=0, \dots, 39$

where k is the channel number.

Table 1. 2.4 GHz ISM and MBAN frequency plan and channel designations

2.4 GHz ISM ¹		MBAN ²		2.4GHz ISM + MBAN	
Channel	Freq (MHz)	Channel	Freq (MHz)	Channel	Freq (MHz)
0	2402	0	2360	28	2390
1	2404	1	2361	29	2391
2	2406	2	2362	30	2392
3	2408	3	2363	31	2393
4	2410	4	2364	32	2394
5	2412	5	2365	33	2395
6	2414	6	2366	34	2396
7	2416	7	2367	35	2397
8	2418	8	2368	36	2398
9	2420	9	2369	0	2402
10	2422	10	2370	1	2404
11	2424	11	2371	2	2406
12	2426	12	2372	3	2408
13	2428	13	2373	4	2410
14	2430	14	2374	5	2412
15	2432	15	2375	6	2414
16	2434	16	2376	7	2416
17	2436	17	2377	8	2418
18	2438	18	2378	9	2420
19	2440	19	2379	10	2422
20	2442	20	2380	11	2424
21	2444	21	2381	12	2426
22	2446	22	2382	13	2428
23	2448	23	2383	14	2430
24	2450	24	2384	15	2432
25	2452	25	2385	16	2434
26	2454	26	2386	17	2436
27	2456	27	2387	18	2438
28	2458	28	2388	19	2440
29	2460	29	2389	20	2442
30	2462	30	2390	21	2444
31	2464	31	2391	22	2446
32	2466	32	2392	23	2448
33	2468	33	2393	24	2450
34	2470	34	2394	25	2452

Table continues on the next page...

Table 1. 2.4 GHz ISM and MBAN frequency plan and channel designations (continued)

2.4 GHz ISM ¹		MBAN ²		2.4GHz ISM + MBAN	
Channel	Freq (MHz)	Channel	Freq (MHz)	Channel	Freq (MHz)
35	2472	35	2395	26	2454
36	2474	36	2396	27	2456
37	2476	37	2397	37	2476
38	2478	38	2398	38	2478
39	2480	39	2399	39	2480

1. ISM frequency of operation spans from 2400.0 MHz to 2483.5 MHz

2. Per FCC guideline rules, Bluetooth Low Energy single mode operation is allowed in these channels.

3.2.2 Other Channel Plans

The RF synthesizer can be configured to use any channel frequency between 2.36 and 2.487 GHz.

3.3 Transceiver Functions

Receive

The receiver architecture is Zero IF (ZIF) where the received signal after passing through RF front end is down-converted to a baseband signal. The signal is filtered and amplified before it is fed to analog-to-digital converter. The digital signal then decimates to a baseband clock frequency before it digitally processes, demodulates and passes on to packet processing/link-layer processing.

Transmit

The transmitter transmits GFSK/FSK modulation having power and channel selection adjustment per user application. After the channel of operation is determined, coarse and fine-tuning is executed within the Frac-N PLL to engage signal lock. After signal lock is established, the modulated buffered signal is routed to a multi-stage amplifier for transmission..

4 Transceiver Electrical Characteristics

4.1 Radio operating conditions

Table 2. Radio operating conditions

Characteristic	Symbol	Min	Typ	Max	Unit
Input Frequency	f_{in}	2.360	—	2.480	GHz
Ambient Temperature Range	T_A	-40	25	105	°C
Maximum RF Input Power	P_{max}	—	—	10	dBm
Crystal Reference Oscillator Frequency ¹	f_{ref}	26 MHz or 32 MHz			

1. The recommended crystal accuracy is ± 40 ppm including initial accuracy, mechanical, temperature, and aging factors.

4.2 Receiver Feature Summary

Table 3. Top-Level Receiver Specifications (TA=25 °C, nominal process unless otherwise noted)

Characteristic ¹	Symbol	Min.	Typ.	Max.	Unit
Supply current power down on VDD_RFX supplies	I_{pdn}	—	200	1000	nA
Supply current Rx On with DC-DC converter enable (Buck; $V_{DCDC_IN} = 3.6$ V, $VDD_1P5_buck = 1.5$ V) . ²	I_{Rxon}	—	6.3	—	mA
Supply current Rx On with DC-DC converter disabled (Bypass) ²	I_{Rxon}	—	17.2	—	mA
Input RF Frequency	f_{in}	2.360	—	2.4835	GHz
GFSK Rx Sensitivity(250 kbit/s GFSK-BT=0.5, h=0.5)	$SENS_{GFSK}$	—	-99	—	dBm
Bluetooth LE Rx Sensitivity ³	$SENS_{BLE}$	—	-95	—	dBm
Noise Figure for maximum gain mode @ typical sensitivity	NF_{HG}	—	7.5	—	dB
Receiver Signal Strength Indicator Range ⁴	$RSSI_{Range}$	-100	—	5 ⁵	dBm
Receiver Signal Strength Indicator Resolution	$RSSI_{Res}$	—	1	—	dB
Typical RSSI variation over frequency		-2	—	2	dB
Typical RSSI variation over temperature		-2	—	2	dB
Narrowband RSSI accuracy ⁶	$RSSI_{Acc}$	-3	—	3	dB
Bluetooth LE Co-channel Interference (Wanted signal at -67 dBm, BER <0.1%. Measurement resolution 1 MHz).			-7		dB
<i>Adjacent/Alternate Channel Performance⁷</i>					
Bluetooth LE Adjacent +/-1 MHz Interference offset (Wanted signal at -67 dBm, BER <0.1%. Measurement resolution 1 MHz.)	$SEL_{BLE, 1\text{ MHz}}$	—	2	—	dB

Table continues on the next page...

Table 3. Top-Level Receiver Specifications (TA=25 °C, nominal process unless otherwise noted) (continued)

Characteristic ¹	Symbol	Min.	Typ.	Max.	Unit
Bluetooth LE Adjacent +/-2 MHz Interference offset (Wanted signal at -67 dBm, BER <0.1%. Measurement resolution 1 MHz.)	SEL _{BLE, 2 MHz}	—	43	—	dB
Bluetooth LE Alternate +/-3 MHz Interference offset (Wanted signal at -67 dBm, BER <0.1%. Measurement resolution 1 MHz.)	SEL _{BLE, 3 MHz}	—	50	—	dB
Bluetooth LE Alternate ≥ +/-4 MHz Interference offset (Wanted signal at -67 dBm, BER <0.1%. Measurement resolution 1 MHz.)	SEL _{BLE, 4+ MHz}	—	50	—	dB
<i>Intermodulation Performance</i>					
Bluetooth LE Intermodulation with continuous wave interferer at ± 3 MHz and modulated interferer is at ± 6 MHz (Wanted signal at -67 dBm, BER<0.1%.)		—	-23	—	dBm
Bluetooth LE Intermodulation with continuous wave interferer at ±5 MHz and modulated interferer is at ±10 MHz (Wanted signal at -67 dBm, BER<0.1%.)		—	-24	—	dBm
<i>Blocking Performance</i>					
Bluetooth LE Out of band blocking from 30 MHz to 1000 MHz and 4000 MHz to 5000 MHz (Wanted signal at -67 dBm, BER<0.1%. Interferer continuous wave signal.) ⁸	—	-2	—	—	dBm
Bluetooth LE Out of band blocking from 1000 MHz to 2000 MHz and 3000 MHz to 4000 MHz (Wanted signal at -67 dBm, BER<0.1%. Interferer continuous wave signal.)	—	-8.4	—	—	dBm
Bluetooth LE Out of band blocking from 2001 MHz to 2339 MHz and 2484 MHz to 2999 MHz (Wanted signal at -67 dBm, BER<0.1%. Interferer continuous wave signal.) ⁹	—	-17	—	—	dBm
Bluetooth LE Out of band blocking from 5000 MHz to 12750 MHz (Wanted signal at -67 dBm, BER<0.1%. Interferer continuous wave signal.) ⁹	—	—	10	—	dBm
Spurious Emission < 1.6 MHz offset (Measured with 100 kHz resolution and average detector. Device transmit on RF channel with center frequency f _c and spurious power measured in 1 MHz at RF frequency f), where f-f _c < 1.6 MHz	—	—	-54	—	dBc
Spurious Emission > 2.5 MHz offset (Measured with 100 kHz resolution and average detector. Device transmit on RF channel with center frequency f _c and spurious power measured in 1 MHz at RF frequency f), where f-f _c > 2.5 MHz ¹⁰	—	—	-70	—	dBc

1. All the Rx parameters are measured at the KW36A/35A/34A RF pins.
2. Transceiver power consumption.
3. Measured at 0.1% BER using 37 byte long packets in maximum gain mode and nominal conditions.
4. Narrow-band RSSI mode.
5. With RSSI_CTRL_0.RSSI_ADJ field calibrated to account for antenna to RF input losses.
6. With one point calibration over frequency and temperature.

7. Bluetooth LE adjacent and alternate selectivity performance is measured with modulated interference signals.
8. Exceptions allowed for carrier frequency sub harmonics.
9. Exceptions allowed for carrier frequency harmonics.
10. Exceptions allowed for twice the reference clock frequency(fref) multiples.

Table 4. Receiver Specifications with Generic FSK Modulations

Modulation Type	Data Rate (kbit/s)	Channel BW (kHz)	Typical Sensitivity (dBm)	Adjacent/Alternate Channel Selectivity (dB) ¹					Co-channel
				Desired signal level (dBm)	Interferer at $-/+1^*$ channel BW offset	Interferer at $-/+2^*$ channel BW offset	Interferer at $-/+3^*$ channel BW offset	Interferer at $-/+4^*$ channel BW offset	
GFSK BT = 0.5, h=0.5	1000	2000	-95	-67	43	50	55	50	-7
	500	1000	-97	-85	40	50	55	55	-7
	250	500	-99	-85	30	40	50	50	-7
GFSK, BT = 0.5, h=0.3	1000	1000	-89	-67	10	38	42	47	-10
	500	800	-92	-85	22	31	37	42	-10
	250	500	-93	-85	20	25	30	34	-13
GFSK, BT = 0.5, h=0.7	1000	2000	-97	-85	45	50	57	60	-7
	500	1000	-98	-85	40	50	55	55	-7
	250	600	-99	-85	30	40	50	50	-7
GMSK BT=0.3	1000	1600	-91	-85	40	46	53	55	-8
	500	800	-93	-85	35	46	50	53	-7
	250	500	-95	-85	30	40	40	50	-7
GMSK, BT = 0.7	1000	2000	-96	-85	44	53	57	60	-7
	500	1000	-97	-85	40	50	55	55	-7
	250	600	-99	-85	30	40	50	50	-7
Generic MSK	1000	3000	-96	-85	43	53	60	63	-7
	500	1600	-97	-85	43	50	60	60	-8
	250	800	-99	-85	35	45	55	55	-7
GFSK BT=0.5, h=1	1000	3000	-96	-85	45	55	55	59	-8
	500	1400	-97	-85	40	45	50	50	-8
	250	800	-98	-85	35	45	45	50	-8

1. Selectivity measured with an unmodulated blocker except for GFSK BT=0.5, h=0.5 1 Mbit/s and GFSK BT=0.5, h=0.32 1 Mbit/s. The desired signal is set at -85 dBm.

4.3 Transmit and PLL Feature Summary

- Supports constant envelope modulation of 2.4 GHz ISM and 2.36 GHz MBAN frequency bands
- Fast PLL Lock time: < 25 μ s
- Reference Frequency:

Transceiver Electrical Characteristics

- 26 MHz and 32 MHz crystals supported for Bluetooth LE and Generic FSK modes

Table 5. Top-Level Transmitter Specifications (TA=25 °C, nominal process unless otherwise noted)

Characteristic ¹	Symbol	Min.	Typ.	Max.	Unit
Supply current power down on VDD_RFX supplies	I_{pdn}	—	200	—	nA
Supply current Tx On with $P_{RF} = 0$ dBm and DC-DC converter enabled (Buck; $VDD_{DCDC_in} = 3.6$ V, $VDD_{1P5_buck} = 1.5$ V) ²	I_{Txone}	—	5.7	—	mA
Supply current Tx On with $P_{RF} = 0$ dBm and DC-DC converter disabled (Bypass) ²	I_{Txond}	—	16	—	mA
Supply current Tx On with $P_{RF} = +3.5$ dBm and DC-DC converter enabled (Buck; $VDD_{DCDC_in} = 3.6$ V, $VDD_{1P5_buck} = 1.5$ V) ²	$I_{TX3.5dBm}$	—	6.9	—	mA
Supply current Tx On with $P_{RF} = +3.5$ dBm and DC-DC converter disabled (Bypass) ²	$I_{TX3.5dBmb}$	—	19	—	mA
Supply current Tx On with $P_{RF} = +5$ dBm and DC-DC converter enabled (Buck; $VDD_{DCDC_in} = 3.6$ V, $VDD_{1P5_buck} = 1.55$ V, LDO-HF bumped) ^{2, 3}	I_{TX5dBm}	—	8.0	—	mA
Supply current Tx On with $P_{RF} = +5$ dBm and DC-DC converter disabled (Bypass, LDO-HF bumped) ^{2, 3}	$I_{TX5dBmb}$	—	21	—	mA
Output RF Frequency	f_{RFout}	2.360	—	2.4835	GHz
Maximum RF Output Power; LDO-HF bumped ⁴	$P_{RF,maxV}$	—	+5	—	dBm
Maximum RF Output power, nominal power supply ⁵	$P_{RF,maxn}$	—	+3.5	—	dBm
Minimum RF Output power, nominal power supply ⁵	$P_{RF,minn}$	—	-30	—	dBm
RF Output power control range	$P_{RF,CR}$	—	34	—	dB
Bluetooth LE Tx Output Spectrum 20dB BW	$TXBW_{BLE}$	1.0	—	—	MHz
Bluetooth LE average frequency deviation using a 00001111 modulation sequence	$\Delta f_{1,avg,BLE}$	—	250	—	kHz
Bluetooth LE average frequency deviation using a 01010101 modulation sequence	$\Delta f_{2,avg,BLE}$	—	220	—	kHz
Bluetooth LE RMS FSK Error	$FSK_{err,BLE}$	—	3%	—	—
Bluetooth LE Maximum Deviation of the Center Frequency ⁶	$F_{cdev,BLE}$	—	±3	—	kHz
Bluetooth LE Adjacent Channel Transmit Power at 2 MHz offset ⁷	$P_{RF2MHz,BLE}$	—	—	-55	dBm
Bluetooth LE Adjacent Channel Transmit Power at ≥ 3 MHz offset ⁷	$P_{RF3MHz,BLE}$	—	—	-59	dBm
Bluetooth LE Frequency Hopping Support			YES		
Second Harmonic of Transmit Carrier Frequency ($P_{out} = P_{RF,max}$) ⁸	$TXH2$	—	-46	—	dBm/MHz
Third Harmonic of Transmit Carrier Frequency ($P_{out} = P_{RF,max}$) ⁸	$TXH3$	—	-58	—	dBm/MHz

1. All the Tx parameters are measured at test hardware SMA connector.
2. Transceiver power consumption.

3. VDD_RFX shall be equal to or higher than 1.55 V to support a TX Pout of +5 dBm.
4. Measured at KW36A/35A/34A RF pins, with BB_LDO_HF_TRIM=1.44 V.
5. Measured at the KW36A/35A/34A RF pins.
6. Maximum drift of carrier frequency of the PLL during a Bluetooth LE packet with a nominal 32 MHz reference crystal.
7. Measured at P_{out} = +5 dBm and recommended Tx match.
8. Harmonic levels based on recommended 2 component match. Transmit harmonic levels depend on the quality of matching components. Additional harmonic margin using a third matching component (1x shunt capacitor) is possible.

Transmit PA driver output as a function of the PA_POWER[5:0] field when measured at the IC pins is as follows:



Figure 4. TX Pout (dBm) as function TX-PA Power Code for default LDO-HF

Table 6. Transmit Output Power as a function of PA_POWER[5:0] with default LDO-HF

PA_POWER[5:0]	TX Pout (dBm) ¹		
	T = -40 °C	T = 25 °C	T = 105 °C
1	-30.1	-31.1	-32.6
2	-24.0	-25.0	-26.4
4	-17.9	-19.0	-20.4
6	-14.5	-15.6	-17.0
8	-12.0	-13.1	-14.5
10	-10.1	-11.2	-12.6
12	-8.5	-9.6	-11.0
14	-7.2	-8.3	-9.7
16	-6.1	-7.2	-8.6

Table continues on the next page...

Table 6. Transmit Output Power as a function of PA_POWER[5:0] with default LDO-HF (continued)

PA_POWER[5:0]	TX Pout (dBm) ¹		
	T = -40 °C	T = 25 °C	T = 105 °C
18	-5.1	-6.2	-7.6
20	-4.2	-5.3	-6.7
22	-3.4	-4.5	-5.9
24	-2.7	-3.8	-5.2
26	-2.0	-3.1	-4.5
28	-1.4	-2.5	-3.9
30	-0.8	-1.9	-3.3
32	-0.3	-1.4	-2.8
34	0.2	-1.0	-2.4
36	0.6	-0.5	-1.9
38	1.1	-0.1	-1.5
40	1.5	0.3	-1.1
42	1.9	0.7	-0.7
44	2.2	1.1	-0.3
46	2.6	1.4	0.0
48	2.9	1.8	0.3
50	3.2	2.1	0.6
52	3.5	2.4	0.9
54	3.7	2.6	1.2
56	3.9	2.9	1.5
58	4.2	3.1	1.7
60	4.4	3.3	1.9
62	4.5	3.5	2.1

1. Tx continuous wave power output at the RF pins with the recommended matching components mounted on PCB.

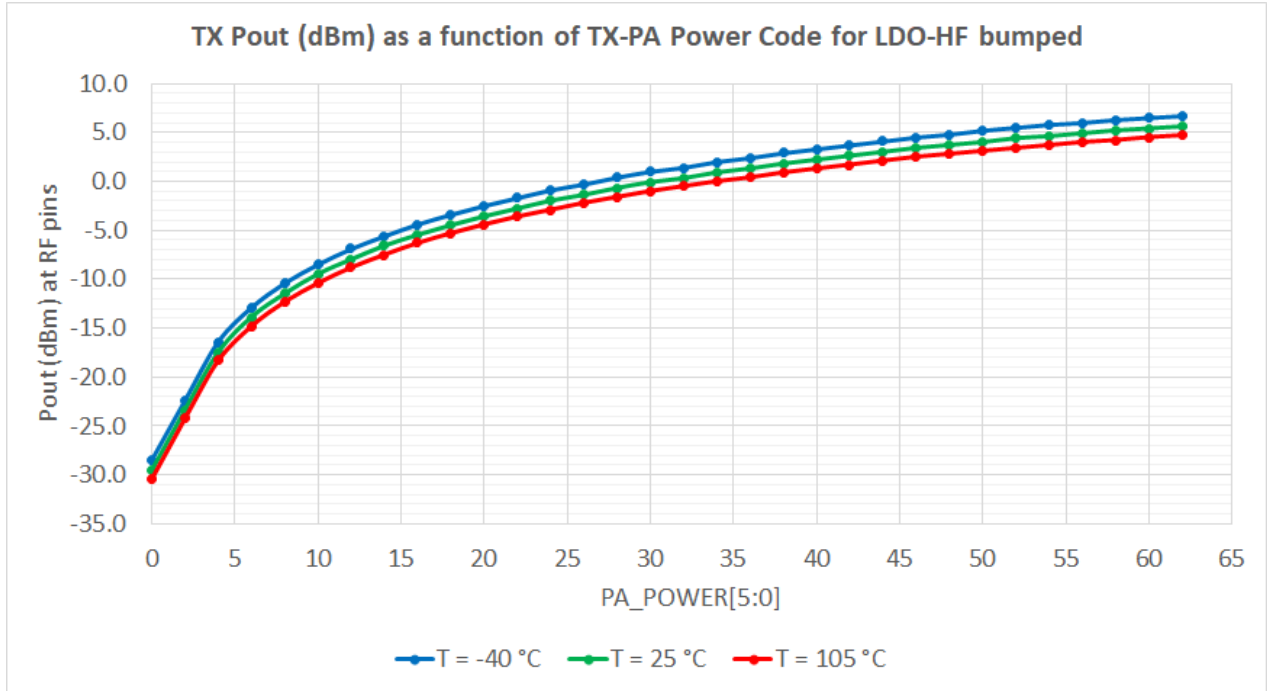

Figure 5. TX Pout (dBm) as a function of TX-PA Power Code for LDO-HF bumped

Table 7. Transmit Output Power as a function of PA_POWER[5:0] with LDO-HF Bumped

PA_POWER[5:0]	TX Pout (dBm) ¹		
	T = -40 °C	T = 25 °C	T = 105 °C
1	-28.5	-29.6	-30.4
2	-22.4	-23.4	-24.2
4	-16.4	-17.5	-18.3
6	-12.9	-13.9	-14.8
8	-10.4	-11.5	-12.3
10	-8.5	-9.5	-10.4
12	-6.9	-8.0	-8.8
14	-5.6	-6.6	-7.5
16	-4.4	-5.5	-6.3
18	-3.4	-4.5	-5.3
20	-2.5	-3.6	-4.4
22	-1.7	-2.8	-3.6
24	-0.9	-2.0	-2.9
26	-0.3	-1.4	-2.2
28	0.4	-0.7	-1.6
30	1.0	-0.1	-1.0
32	1.4	0.3	-0.5

Table continues on the next page...

Table 7. Transmit Output Power as a function of PA_POWER[5:0] with LDO-HF Bumped (continued)

PA_POWER[5:0]	TX Pout (dBm) ¹		
	T = -40 °C	T = 25 °C	T = 105 °C
34	2.0	0.9	0.0
36	2.4	1.3	0.4
38	2.9	1.8	0.9
40	3.3	2.2	1.3
42	3.7	2.6	1.7
44	4.1	3.0	2.1
46	4.5	3.4	2.5
48	4.8	3.7	2.8
50	5.2	4.0	3.1
52	5.5	4.4	3.4
54	5.8	4.6	3.7
56	6.0	4.9	4.0
58	6.3	5.2	4.2
60	6.5	5.4	4.5
62	6.7	5.6	4.7

1. Tx continuous wave power output at the RF pins with the recommended matching components mounted on PCB.

5 System and Power Management

5.1 Power Management

The KW36A/35A/34A includes internal power management features that can be used to control the power usage. The power management of the KW36A/35A/34A includes Power Management Controller (PMC) and a DC-DC converter which can operate in a buck or bypass configuration. The PMC is designed such that the RF radio remains in state-retention while the core is in various stop modes. It makes sure that the device can stay in low current consumption mode while the RF radio can wake-up quick enough for communication.

5.1.1 DC-DC Converter

The features of the DC-DC converter include the following:

- Single inductor, multiple outputs.
- Buck mode (pin selectable; CFG=VDCDC_IN).
- Continuous or pulsed operation (hardware/software configurable).
- Power switch input to allow external control of power up, and to select DC-DC bypass mode in which all the SoC power supplies (see [Table 3](#)) are externally provided.
- Output signal to indicate power stable. Purpose is for the rest of the chip to be used as a POR.
- Scaled battery output voltage suitable for SAR ADC utilization.
- Internal oscillator for support when the reference oscillator is not present.

5.2 Modes of Operation

The Arm Cortex-M0+ core in the KW36A/35A/34A has three primary modes of operation: Run, Wait, and Stop modes. For each run mode, there is a corresponding wait and stop mode. Wait modes are similar to Arm sleep modes. Stop modes are similar to Arm deep sleep modes. The very low-power run (VLPR) operation mode can drastically reduce runtime power when the maximum bus frequency is not required to handle the application needs.

The WFI instruction invokes both wait and stop modes. The primary modes are augmented in a number of ways to provide lower power based on application needs.

5.2.1 Power modes

The power management controller (PMC) provides multiple power options to allow the user to optimize power consumption for the level of functionality needed.

Depending on the stop requirements of the user application, various stop modes are available that provide state retention, partial power down, or full power down of certain logic and/or memory. I/O states are held in all modes of operation. The following table compares the various power modes available.

For each run mode, there is a corresponding wait and stop mode. Wait modes are similar to Arm sleep modes. Stop modes (VLPS, STOP) are similar to Arm sleep deep mode. The very-low-power run (VLPR) operating mode can drastically reduce runtime power when the maximum bus frequency is not required to handle the application needs.

The three primary modes of operation are run, wait, and stop. The WFI instruction invokes either wait or stop depending on the SLEEPDEEP bit in Cortex-M0+ System Control Register. The primary modes are augmented in a number of ways to provide lower power based on application needs.

Table 8. Power modes (At 25 deg C)

Power mode	Description	CPU recovery method	Radio
Normal Run (all peripherals clock off)	Allows maximum performance of chip.	—	Radio can be active
Normal Wait - via WFI	Allows peripherals to function, while allowing CPU to go to sleep reducing power.	Interrupt	
Normal Stop - via WFI	Places chip in static state. Lowest power mode that retains all registers while maintaining LVD protection.	Interrupt	
PStop2 (Partial Stop 2)	Core and system clocks are gated. Bus clock remains active. Masters and slaves clocked by bus clock remain in Run or VLPRun mode. The clock generators in MCG and the on-chip regulator in the PMC also remain in Run or VLPRun mode.	Interrupt	
PStop1 (Partial Stop 1)	Core, system clocks, and bus clock are gated. All bus masters and slaves enter Stop mode. The clock generators in MCG and the on-chip regulator in the PMC also remain in Run or VLPRun mode.	Interrupt	
VLPR (Very Low-power Run) (all peripherals off)	Reduced frequency (1 MHz) Flash access mode, regulator in low-power mode, LVD off. Internal oscillator can provide low-power 4 MHz source for core. (Values @2 MHz core/ 1 MHz bus and flash, module off, execution from flash). Biasing is disabled when DC-DC is configured for continuous mode in VLPR/W	—	Radio operation is possible only when DC-DC is configured for continuous mode. ¹ However, there may be insufficient MIPS with a 4 MHz MCU to support much in the way of radio operation.
VLPW (Very Low-power Wait) - via WFI (all peripherals off)	Similar to VLPR, with CPU in sleep to further reduce power. (Values @4 MHz core/ 1 MHz bus, module off) Biasing is disabled when DC-DC is configured for continuous mode in VLPR/W	Interrupt	
VLPS (Very Low-power Stop) via WFI	Places MCU in static state with LVD operation off. Lowest power mode with ADC and all pin interrupts functional. LPTMR, RTC, CMP can be operational. Biasing is disabled when DC-DC is configured for continuous mode in VLPS.	Interrupt	
LLS3 (Low Leakage Stop)	State retention power mode. LLWU, LPTMR, RTC, CMP can be operational. All of the radio Sea of Gates(SOG) logic is in state retention.	Wake-up Interrupt	Radio SOG is in state retention in LLSx. The Bluetooth LE/Generic FSK DSM ² logic can be active using the 32 kHz clock
LLS2 (Low Leakage Stop)	State retention power mode. LLWU, LPTMR, RTC, CMP can be operational. 16 KB or 32 KB of programmable RAM can be powered on. All of the radio SOG logic is in state retention.	Wake-up Interrupt	

Table continues on the next page...

Table 8. Power modes (At 25 deg C) (continued)

Power mode	Description	CPU recovery method	Radio
VLLS3 (Very Low Leakage Stop3)	Full SRAM retention. LLWU, LPTMR, RTC, CMP can be operational. All of the radio SOG logic is in state retention.	Wake-up Reset	Radio SOG is in state retention in VLLS3/2. The Bluetooth LE/Generic FSK DSM logic can be active using the 32 kHz clock.
VLLS2 (Very Low Leakage Stop2)	Partial SRAM retention. 16 KB or 32 KB of programmable RAM can be powered on. LLWU, LPTMR, RTC, CMP can be operational. All of the radio SOG logic is in state retention.	Wake-up Reset	
VLLS1 (Very Low Leakage Stop1) with RTC + 32 kHz OSC	All SRAM powered off. The 32-byte system register file remains powered for customer-critical data. LLWU, LPTMR, RTC, CMP can be operational. Radio logic is power gated.	Wake-up Reset	Radio operation not supported. The Radio SOG is power-gated in VLLS1. Radio state is lost at VLLS1 and lower power states.
VLLS1 (Very Low Leakage Stop1) with LPTMR + LPO	All SRAM powered off. The 32-byte system register file remains powered for customer-critical data. LLWU, LPTMR, RTC, CMP can be operational.	Wake-up Reset	
VLLS0 (Very Low Leakage Stop0) with Brown-out Detection	VLLS0 is not supported with DC-DC. The 32-byte system register file remains powered for customer-critical data. Disable all analog modules in PMC and retains I/O state and DGO state. LPO disabled, POR brown-out detection enabled, Pin interrupt only. Radio logic is power gated.	Wake-up Reset	Radio operation not supported. The Radio digital is power-gated in VLLS0.
VLLS0 (Very Low Leakage Stop0) without Brown-out Detection	VLLS0 is not supported with DC-DC buck configuration but is supported with bypass configuration. The 32-byte system register file remains powered for customer-critical data. Disable all analog modules in PMC and retains I/O state and DGO state. LPO disabled, POR brown-out detection disabled, Pin interrupt only. Radio logic is power gated.	Wake-up Reset	

1. Biasing is disabled, but the Flash is in a low-power mode for VLPx, so this configuration can realize some power savings over use of Run/Wait/Stop.
2. DSM refers to Radio's deep sleep mode. DSM does not refer to the Arm sleep deep mode.

6 KW36A/35A/34A Electrical Characteristics

6.1 AC electrical characteristics

Unless otherwise specified, propagation delays are measured from the 50% to the 50% point, and rise and fall times are measured at the 20% and 80% points, as shown in the following figure.

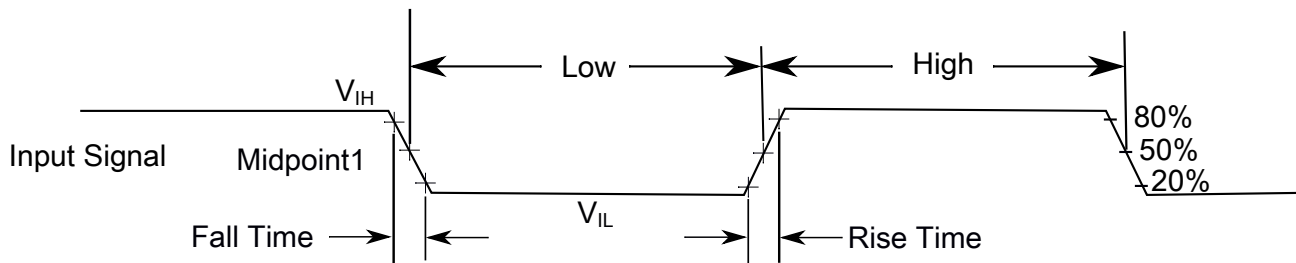

The midpoint is $V_{IL} + (V_{IH} - V_{IL}) / 2$

Figure 6. Input signal measurement reference

All digital I/O switching characteristics, unless otherwise specified, assume that the output pins have the following characteristics.

- $C_L=30$ pF loads
- Slew rate disabled
- Normal drive strength

6.2 Nonswitching electrical specifications

6.2.1 Voltage and current operating requirements

Table 9. Voltage and current operating requirements

Symbol	Description	Min.	Max.	Unit	Notes
V_{DD}	Supply voltage	1.71	3.6	V	
V_{DD_1P5}	DCDC V_{DD_1P5} output pin	1.425	3.6	V	1
V_{DDA}	Analog supply voltage	1.71	3.6	V	
$V_{DD} - V_{DDA}$	V_{DD} -to- V_{DDA} differential voltage	-0.1	0.1	V	
$V_{SS} - V_{SSA}$	V_{SS} -to- V_{SSA} differential voltage	-0.1	0.1	V	
V_{IH}	Input high voltage <ul style="list-style-type: none"> • $2.7\text{ V} \leq V_{DD} \leq 3.6\text{ V}$ • $1.7\text{ V} \leq V_{DD} \leq 2.7\text{ V}$ 	$0.7 \times V_{DD}$ $0.75 \times V_{DD}$	— —	V V	
V_{IL}	Input low voltage <ul style="list-style-type: none"> • $2.7\text{ V} \leq V_{DD} \leq 3.6\text{ V}$ • $1.7\text{ V} \leq V_{DD} \leq 2.7\text{ V}$ 	— —	$0.35 \times V_{DD}$ $0.3 \times V_{DD}$	V V	
V_{HYS}	Input hysteresis	$0.06 \times V_{DD}$	—	V	
I_{ICIO}	IO pin negative DC injection current — single pin <ul style="list-style-type: none"> • $V_{IN} < V_{SS}-0.3\text{V}$ 	-3	—	mA	2

Table continues on the next page...

Table 9. Voltage and current operating requirements (continued)

Symbol	Description	Min.	Max.	Unit	Notes
I_{ICcont}	Contiguous pin DC injection current — regional limit, includes sum of negative injection currents of 16 contiguous pins <ul style="list-style-type: none"> Negative current injection 	-25	—	mA	
V_{ODPU}	Open drain pullup voltage level	V_{DD}	V_{DD}	V	3
V_{RAM}	V_{DD} voltage required to retain RAM	1.2	—	V	

- This limit applies in any DCDC mode.
- All I/O pins are internally clamped to V_{SS} through an ESD protection diode. There is no diode connection to V_{DD} . If V_{IN} greater than V_{IO_MIN} ($= V_{SS} - 0.3$ V) is observed, then there is no need to provide current limiting resistors at the pads. If this limit cannot be observed then a current limiting resistor is required. The negative DC injection current limiting resistor is calculated as $R = (V_{IO_MIN} - V_{IN}) / |I_{ICIO}|$.
- Open drain outputs must be pulled to V_{DD} .

6.2.2 LVD and POR operating requirements

Table 10. V_{DD} supply LVD and POR operating requirements

Symbol	Description	Min.	Typ.	Max.	Unit	Notes
V_{POR}	Falling V_{DD} POR detect voltage	0.8	1.1	1.5	V	
$V_{POR_VDD_1P5}$	V_{DD_1P5} POR threshold	1.25	1.31	1.37	V	
V_{LVDH}	Falling low-voltage detect threshold — high range (LVDV = 01)	2.48	2.56	2.64	V	
V_{LVW1H}	Low-voltage warning thresholds — high range <ul style="list-style-type: none"> Level 1 falling (LVWV = 00) 	2.62	2.70	2.78	V	1
V_{LVW2H}	<ul style="list-style-type: none"> Level 2 falling (LVWV = 01) 	2.72	2.80	2.88	V	
V_{LVW3H}	<ul style="list-style-type: none"> Level 3 falling (LVWV = 10) 	2.82	2.90	2.98	V	
V_{LVW4H}	<ul style="list-style-type: none"> Level 4 falling (LVWV = 11) 	2.92	3.00	3.08	V	
V_{HYSH}	Low-voltage inhibit reset/recover hysteresis — high range	—	± 60	—	mV	
V_{LVDL}	Falling low-voltage detect threshold — low range (LVDV=00)	1.54	1.60	1.66	V	
V_{LVW1L}	Low-voltage warning thresholds — low range <ul style="list-style-type: none"> Level 1 falling (LVWV = 00) 	1.74	1.80	1.86	V	1
V_{LVW2L}	<ul style="list-style-type: none"> Level 2 falling (LVWV = 01) 	1.84	1.90	1.96	V	
V_{LVW3L}	<ul style="list-style-type: none"> Level 3 falling (LVWV = 10) 	1.94	2.00	2.06	V	
V_{LVW4L}	<ul style="list-style-type: none"> Level 4 falling (LVWV = 11) 	2.04	2.10	2.16	V	
V_{HYSL}	Low-voltage inhibit reset/recover hysteresis — low range	—	± 40	—	mV	

Table continues on the next page...

Table 10. V_{DD} supply LVD and POR operating requirements (continued)

Symbol	Description	Min.	Typ.	Max.	Unit	Notes
V_{BG}	Bandgap voltage reference	0.97	1.00	1.03	V	
t_{LPO}	Internal low-power oscillator period — factory trimmed	900	1000	1100	μ s	

1. Rising thresholds are falling threshold + hysteresis voltage

6.2.3 Voltage and current operating behaviors

Table 11. Voltage and current operating behaviors

Symbol	Description	Min.	Max.	Unit	Notes
V_{OH}	Output high voltage — Normal drive pad (except RESET_b) <ul style="list-style-type: none"> • $2.7\text{ V} \leq V_{DD} \leq 3.6\text{ V}$, $I_{OH} = -5\text{ mA}$ • $1.71\text{ V} \leq V_{DD} \leq 2.7\text{ V}$, $I_{OH} = -2.5\text{ mA}$ • $1.71\text{ V} \leq V_{DD} \leq 2.7\text{ V}$, $I_{OH} = -1\text{ mA}$ 	$V_{DD} - 0.5$ $V_{DD} - 0.5$ $V_{DD} - 0.35$	— — —	V V V	1, 2
V_{OH}	Output high voltage — High drive pad (except RESET_b) <ul style="list-style-type: none"> • $2.7\text{ V} \leq V_{DD} \leq 3.6\text{ V}$, $I_{OH} = -20\text{ mA}$ • $1.71\text{ V} \leq V_{DD} \leq 2.7\text{ V}$, $I_{OH} = -10\text{ mA}$ 	$V_{DD} - 0.5$ $V_{DD} - 0.5$	— —	V V	1, 2
I_{OHT}	Output high current total for all ports	—	100	mA	
V_{OL}	Output low voltage — Normal drive pad <ul style="list-style-type: none"> • $2.7\text{ V} \leq V_{DD} \leq 3.6\text{ V}$, $I_{OL} = 5\text{ mA}$ • $1.71\text{ V} \leq V_{DD} \leq 2.7\text{ V}$, $I_{OL} = 2.5\text{ mA}$ 	— —	0.5 0.5	V V	1
V_{OL}	Output low voltage — High drive pad <ul style="list-style-type: none"> • $2.7\text{ V} \leq V_{DD} \leq 3.6\text{ V}$, $I_{OL} = 20\text{ mA}$ • $1.71\text{ V} \leq V_{DD} \leq 2.7\text{ V}$, $I_{OL} = 10\text{ mA}$ 	— —	0.5 0.5	V V	1
I_{OLT}	Output low current total for all ports	—	100	mA	
I_{IN}	Input leakage current (per pin) for full temperature range	—	500	nA	3
I_{IN}	Input leakage current (per pin) at 25 °C	—	0.025	μ A	3
I_{IN}	Input leakage current (total all pins) for full temperature range	—	5	μ A	3
R_{PU}	Internal pullup resistors	20	50	k Ω	4

1. PTB0-1 and PTC0-3, PTC6, PTC7, PTC17, PTC18 I/O have both high drive and normal drive capability selected by the associated PTx_PCRn[DSE] control bit. All other GPIOs are normal drive only.
2. The reset pin only contains an active pull-up device when configured as the RESET signal or as a GPIO. When configured as a GPIO output, it acts as a pseudo open drain output.
3. Measured at $V_{DD} = 3.6\text{ V}$.

4. Measured at V_{DD} supply voltage = V_{DD} min and $V_{input} = V_{SS}$.

6.2.4 Power mode transition operating behaviors

All specifications except t_{POR} and $VLLSx \rightarrow RUN$ recovery times in the following table assume this clock configuration:

- CPU and system clocks = 48 MHz
- Bus and flash clock = 24 MHz
- FEI clock mode

POR and $VLLSx \rightarrow RUN$ recovery use FEI clock mode at the default CPU and system frequency of 21 MHz, and a bus and flash clock frequency of 10.5 MHz.

Table 12. Power mode transition operating behaviors

Symbol	Description	Max.	Unit	Notes
t_{POR}	After a POR event, amount of time from the point V_{DD} reaches 1.8 V to execution of the first instruction across the operating temperature range of the chip.	300	μs	1
	• $VLLS0 \rightarrow RUN$	169.0	μs	
	• $VLLS1 \rightarrow RUN$	168.9	μs	
	• $VLLS2 \rightarrow RUN$	97.3	μs	
	• $VLLS3 \rightarrow RUN$	97.3	μs	
	• $LLS \rightarrow RUN$	6.3	μs	
	• $VLPS \rightarrow RUN$	6.2	μs	
	• $STOP \rightarrow RUN$	6.2	μs	

1. Normal boot (FTFA_FOPT[LPBOOT]=11). When the DC-DC converter is in bypass mode, TPOR will not meet the 300 μs spec when 1) $VDD_1P5 < 1.6$ V at 25 °C and 125 °C. 2) $1.5V \leq VDD_1P5 \leq 1.8$ V. For the bypass mode special case where $VDD_1P5 = VDD_1P8$, TPOR did not meet the 300 μs maximum spec when the supply slew rate ≤ 100 V/s.

6.2.5 Power consumption operating behaviors

Table 13. Power consumption operating behaviors - Bypass Mode

Symbol	Description	Typ.	Max.	Unit	Notes
I _{DDA}	Analog supply current	—	See note	mA	1
I _{DD_RUNCO_C M}	Run mode current in compute operation - 48 MHz core / 24 MHz flash / bus disabled, LPTMR running using LPO clock at 1kHz, CoreMark benchmark code executing from flash at 3.0 V	6.80	8.41	mA	2, 3
I _{DD_RUNCO}	Run mode current in compute operation - 48 MHz core / 24 MHz flash / bus clock disabled, code of while(1) loop executing from flash at 3.0 V	4.05	4.98	mA	3, 4
I _{DD_RUN}	Run mode current - 48 MHz core / 24 MHz bus and flash, all peripheral clocks disabled, code of while(1) loop executing from flash at 3.0 V	5.00	6.01	mA	3, 4
I _{DD_RUN}	Run mode current - 48 MHz core / 24 MHz bus and flash, all peripheral clocks enabled, code of while(1) loop executing from flash at 3.0 V				3, 4, 5
	at 25 °C	6.48	6.70	mA	
	at 70 °C	6.77	6.96	mA	
	at 105 °C	7.13	7.90	mA	
I _{DD_WAIT}	Wait mode current - core disabled / 48 MHz system / 24 MHz bus / flash disabled (flash doze enabled), all peripheral clocks disabled at 3.0 V	3.07	4.31	mA	4
I _{DD_WAIT}	Wait mode current - core disabled / 24 MHz system / 24 MHz bus / flash disabled (flash doze enabled), all peripheral clocks disabled at 3.0 V	2.29	3.15	mA	4
I _{DD_PSTOP2}	Stop mode current with partial stop 2 clocking option - core and system disabled / 10.5 MHz bus at 3.0 V	2.32	3.11	mA	4
I _{DD_VLPRCO_ CM}	Very-low-power run mode current in compute operation - 4 MHz core / 0.8 MHz flash / bus clock disabled, LPTMR running using LPO clock at 1 kHz reference clock, CoreMark benchmark code executing from flash at 3.0 V	766.9	1538	μA	6
I _{DD_VLPRCO}	Very-low-power run mode current in compute operation - 4 MHz core / 0.8 MHz flash / bus clock disabled, code of while(1) loop executing from flash at 3.0 V	158.45	377	μA	7
I _{DD_VLPR}	Very-low-power run mode current - 4 MHz core / 0.8 MHz bus and flash, all peripheral clocks disabled, code of while(1) loop executing from flash at 3.0 V	185.26	410	μA	7
I _{DD_VLPR}	Very-low-power run mode current - 4 MHz core / 0.8 MHz bus and flash, all peripheral clocks enabled, code of while(1) loop executing from flash at 3.0 V	240.96	805.3	μA	5, 7
I _{DD_VLPW}	Very-low-power wait mode current - core disabled / 4 MHz system / 0.8 MHz bus / flash disabled (flash doze enabled), all peripheral clocks disabled at 3.0 V	133.95	552.8	μA	7
I _{DD_STOP}	Stop mode current at 3.0 V				

Table continues on the next page...

Table 13. Power consumption operating behaviors - Bypass Mode (continued)

Symbol	Description	Typ.	Max.	Unit	Notes
	at 25 °C at 70 °C at 105 °C	204.98 291.89 599.46	308.3 872.5 1662	μA μA μA	
I _{DD_VLPS}	Very-low-power stop mode current at Bypass mode(3.0 V), at 25 °C at 70 °C at 105 °C	6.4 30.64 157	18 76.6 328	μA μA μA	
I _{DD_LLS3}	Low-leakage stop mode 3 current at Bypass mode(3.0 V), at 25 °C at 70 °C at 105 °C	2.57 11.76 50.92	4.31 26.07 105.4	μA μA μA	
I _{DD_LLS2}	Low-leakage stop mode 2 current at Bypass mode(3.0 V), at 25 °C at 70 °C at 105 °C	2.35 9.74 42.34	3.30 21.40 80.23	μA μA μA	
I _{DD_VLLS3}	Very-low-leakage stop mode 3 current at Bypass mode(3.0 V), at 25 °C at 70 °C at 105 °C	2.13 10.78 46.70	3.3 22.97 83.54	μA μA μA	
I _{DD_VLLS2}	Very-low-leakage stop mode 2 current at Bypass mode(3.0 V), at 25 °C at 70 °C at 105 °C	1.84 7.88 34.76	2.40 15.19 57.85	μA μA μA	
I _{DD_VLLS1}	Very-low-leakage stop mode 1 current at Bypass mode(3.0 V), at 25°C at 70°C at 105°C	851.45 3.57 17.62	1027.8 6.28 23.06	nA μA μA	
I _{DD_VLLS0}	Very-low-leakage stop mode 0 current (SMC_STOPCTRL[PORPO] = 0) at 3.0 V at 25 °C at 70 °C at 105 °C	433.00 3.15 17.2	720.3 6.14 23.2	nA μA μA	

Table continues on the next page...

Table 13. Power consumption operating behaviors - Bypass Mode (continued)

Symbol	Description	Typ.	Max.	Unit	Notes
I _{DD_VLLS0}	Very-low-leakage stop mode 0 current (SMC_STOPCTRL[PORPO] = 1) at 3.0 V				8
	at 25 °C	258.12	516.43	nA	
	at 70 °C	2.97	5.81	μA	
	at 105 °C	16.9	22.4	μA	

1. The analog supply current is the sum of the active or disabled current for each of the analog modules on the device. See each module's specification for its supply current.
2. MCG configured for FEI mode. CoreMark benchmark compiled using IAR 7.70 with optimization level high, optimized for balanced.
3. Radio is off.
4. MCG configured for FEI mode.
5. Incremental current consumption from peripheral activity is not included.
6. MCG configured for BLPI mode. CoreMark benchmark compiled using IAR 7.70 with optimization level high, optimized for balanced.
7. MCG configured for BLPI mode.
8. No brownout.

Table 14. Power consumption operating behaviors - Buck Mode¹

Symbol	Description	Typ.	Max.	Unit	Notes	
I _{DDA}	Analog supply current	—	See note	mA	2	
I _{DD_RUNCO}	Run mode current in compute operation - 48 MHz core / 24 MHz flash / bus clock disabled, code of while(1) loop executing from flash at 3.0 V	3.51	—	mA	3, 4	
I _{DD_RUN}	Run mode current - 48 MHz core / 24 MHz bus and flash, all peripheral clocks disabled, code of while(1) loop executing from flash at 3.0 V	4.00	—	mA	3, 4	
I _{DD_RUN}	Run mode current - 48 MHz core / 24 MHz bus and flash, all peripheral clocks enabled, code of while(1) loop executing from flash at 3.0 V				3, 4, 5	
		at 25 °C	5.81	—		mA
		at 70 °C	5.92	—		mA
		at 105 °C	6.36	—		mA
I _{DD_WAIT}	Wait mode current - core disabled / 48 MHz system / 24 MHz bus / flash disabled (flash doze enabled), all peripheral clocks disabled at 3.0 V	2.97	—	mA	3	
I _{DD_WAIT}	Wait mode current - core disabled / 24 MHz system / 24 MHz bus / flash disabled (flash doze enabled), all peripheral clocks disabled at 3.0 V	2.51	—	mA	3	
I _{DD_PSTOP2}	Stop mode current with partial stop 2 clocking option - core and system disabled / 10.5 MHz bus at 3.0 V	2.33	—	mA	3	
I _{DD_VLPRCO}	Very-low-power run mode current in compute operation - 4 MHz core / 0.8 MHz flash / bus clock disabled, code of while(1) loop executing from flash at 3.0 V	101.75	—	μA	6	

Table continues on the next page...

Table 14. Power consumption operating behaviors - Buck Mode1 (continued)

Symbol	Description	Typ.	Max.	Unit	Notes
I _{DD_VLPR}	Very-low-power run mode current - 4 MHz core / 0.8 MHz bus and flash, all peripheral clocks disabled, code of while(1) loop executing from flash at 3.0 V	132.17	—	μA	6
I _{DD_VLPR}	Very-low-power run mode current - 4 MHz core / 0.8 MHz bus and flash, all peripheral clocks enabled, code of while(1) loop executing from flash at 3.0 V	167.65	—	μA	5, 6
I _{DD_VLPW}	Very-low-power wait mode current - core disabled / 4 MHz system / 0.8 MHz bus / flash disabled (flash doze enabled), all peripheral clocks disabled at 3.0 V	105.72	—	μA	6
I _{DD_STOP}	Stop mode current at 3.0 V				
	at 25 °C	1.43	2.32	mA	
	at 70 °C	1.56	4.35	mA	
	at 105 °C	1.99	4.68	mA	
I _{DD_VLPS}	Very-low-power stop mode current at Buck mode(3.0 V),				7
	at 25 °C	4.18	14.98	μA	
	at 70 °C	44.30	110	μA	
	at 105 °C	218.64	446	μA	
I _{DD_LLS3}	Low-leakage stop mode 3 current at Buck mode(3.0 V),				7
	at 25 °C	2.64	4.89	μA	
	at 70 °C	15.27	25.51	μA	
	at 105 °C	81.93	104.35	μA	
I _{DD_LLS2}	Low-leakage stop mode 2 current at Buck mode(3.0 V),				7
	at 25 °C	2.46	3.80	μA	
	at 70 °C	10.14	21.14	μA	
	at 105 °C	63.49	80.21	μA	
I _{DD_VLLS3}	Very-low-leakage stop mode 3 current at Buck mode(3.0 V),				7
	at 25 °C	2.03	3.28	μA	
	at 70 °C	12.44	23.8	μA	
	at 105 °C	62.23	83.9	μA	
I _{DD_VLLS2}	Very-low-leakage stop mode 2 current at Buck mode(3.0 V),				7
	at 25 °C	1.79	2.43	μA	
	at 70 °C	8.87	16.7	μA	
	at 105 °C	49.39	62.94	μA	
I _{DD_VLLS1}	Very-low-leakage stop mode 1 current at Buck mode(3.0 V),				7

Table 14. Power consumption operating behaviors - Buck Mode1

Symbol	Description	Typ.	Max.	Unit	Notes
	at 25 °C	0.830	1.07	μA	
	at 70 °C	4.95	10.67	μA	
	at 105 °C	27.51	36.14	μA	

1. The device was configured in buck mode auto-start to perform the measurements. The DCDC_IN was powered with 3.0 V. VDD_1P8OUT was configured to output 1.8 V and VDD_1P5OUT_PMCIN was configured to output 1.5 V.
2. The analog supply current is the sum of the active or disabled current for each of the analog modules on the device. See each module's specification for its supply current.
3. MCG configured for FEI mode.
4. Radio is off.
5. Incremental current consumption from peripheral activity is not included.
6. MCG configured for BLPI mode.
7. DCDC configured in pulsed mode.

Table 15. Low power mode peripheral adders — typical value (Bypass Mode)

Symbol	Description	Temperature (°C)					Unit
		-40	25	50	70	85	
I _{REFSTEN4MHz}	4 MHz internal reference clock (IRC) adder. Measured by entering STOP or VLPS mode with 4 MHz IRC enabled.	46	46	47	47	47	μA
I _{REFSTEN32KHz}	32 kHz internal reference clock (IRC) adder. Measured by entering STOP mode with the 32 kHz IRC enabled.	88	91	90	89	88	μA
I _{REFSTEN32KHz}	External 32 kHz crystal clock adder by means of the RTC bits. Measured by entering all modes with the crystal enabled.						
	VLLS1	1.4	1.3	1.6	2.4	4.1	μA
	VLLS2	1.6	1.5	1.9	4.2	7.7	
	VLLS3	2.7	1.9	2.9	7.7	15	
	LLS2	1.8	1.4	1.7	4.1	8	
	LLS3	2.6	1.7	2.8	7.6	15.2	
I _{CMP}	CMP peripheral adder measured by placing the device in VLLS1 mode with CMP enabled using the 6-bit DAC and a single external input for compare. Includes 6-bit DAC power consumption.	22	19	20	21	21	μA
I _{RTC}	RTC peripheral adder measured by placing the device in VLLS1 mode with external 32 kHz crystal enabled by means of the RTC_CR[OSCE] bit and the RTC ALARM set for 1 minute. Includes ERCLK32K (32 kHz external crystal) power consumption.	1.4	1.3	1.6	2.4	4.3	μA
I _{LPUART}	LPUART peripheral adder measured by placing the device in STOP or VLPS mode						

Table continues on the next page...

Table 15. Low power mode peripheral adders — typical value (Bypass Mode) (continued)

Symbol	Description	Temperature (°C)					Unit
		-40	25	50	70	85	
	with selected clock source waiting for RX data at 115200 baud rate. Includes selected clock source power consumption. MCGIRCLK (4 MHz internal reference clock)	53	54	54	54	54	μA
I_{LPTMR}	LPTMR peripheral adder measured by placing the device in VLLS1 mode with LPTMR enabled using LPO.	30	30	30	85	100	nA
I_{TPM}	TPM peripheral adder measured by placing the device in STOP or VLPS mode with selected clock source configured for output compare generating 100 Hz clock signal. No load is placed on the I/O generating the clock signal. Includes selected clock source and I/O switching currents. MCGIRCLK (4 MHz internal reference clock)	58	59	59	59	59	μA
I_{BG}	Bandgap adder when BGEN bit is set and device is placed in VLPx, LLS, or VLLSx mode.	76	82	85	87	87	μA
I_{ADC}	ADC peripheral adder combining the measured values at V_{DD} and V_{DDA} by placing the device in STOP or VLPS mode. ADC is configured for low-power mode using the internal clock and continuous conversions.	331	327	327	327	328	μA

6.2.6 Diagram: Typical I_{DD_RUN} operating behavior

The following data is measured from previous devices with same MCU core (Arm® Cortex-M0+) under these conditions:

- No GPIOs toggled
- Code execution from flash with cache enabled
- For the ALLOFF curve, all peripheral clocks are disabled except FTFA

NOTE

The results in the following graphs are obtained using the device in Bypass mode.



Figure 7. Run mode supply current vs. core frequency



Figure 8. VLPR mode current vs. core frequency

6.2.7 SoC Power Consumption

Full KW36A/35A/34A system-on-chip (SoC) power consumption is a function of the many configurations possible for the MCU platform and its peripherals including the 2.4 GHz radio and the DC-DC converter. A few measured SoC configurations are as follows:

Table 16. SoC Power Consumption with default LDO-HF

MCU State	Flash State	Radio State	DC-DC State	Typical Average IC current	Unit
STOP	Doze	Rx	Buck (V _{DCDC_IN} =3.6 V)	8.5	mA
STOP	Doze	Tx (at 0 dBm)	Buck (V _{DCDC_IN} =3.6 V)	7.8	mA
STOP	Doze	Tx (at +3.5 dBm)	Buck (V _{DCDC_IN} =3.6 V)	9.2	mA

Table continues on the next page...

Table 16. SoC Power Consumption with default LDO-HF (continued)

MCU State	Flash State	Radio State	DC-DC State	Typical Average IC current	Unit
RUN	Enabled	Rx	Buck ($V_{DCDC_IN}=3.6\text{ V}$)	10.4	mA
RUN	Enabled	Tx (at 0 dBm)	Buck ($V_{DCDC_IN}=3.6\text{ V}$)	9.9	mA
RUN	Enabled	Tx (at +3.5 dBm)	Buck ($V_{DCDC_IN}=3.6\text{ V}$)	11.7	mA
STOP	Doze	Rx	Disabled/Bypass	17.3	mA
STOP	Doze	Tx (at 0 dBm)	Disabled/Bypass	15.9	mA
STOP	Doze	Tx (at +3.5 dBm)	Disabled/Bypass	18.3	mA
RUN	Enabled	Rx	Disabled/Bypass	21.5	mA
RUN	Enabled	Tx (at 0 dBm)	Disabled/Bypass	19.9	mA
RUN	Enabled	Tx (at +3.5 dBm)	Disabled/Bypass	22.4	mA

Table 17. SoC Power Consumption with LDO-HF bumped

MCU State	Flash State	Radio State	DC-DC State	Typical Average IC current	Unit
STOP	Doze	Rx (LDO-HF Bumped)	Buck ($V_{DCDC_IN}=3.6\text{ V}$)	8.7	mA
STOP	Doze	Tx (LDO-HF Bumped, +5 dBm)	Buck ($V_{DCDC_IN}=3.6\text{ V}$)	10.3	mA
RUN	Enabled	Rx (LDO-HF Bumped)	Buck ($V_{DCDC_IN}=3.6\text{ V}$)	11.3	mA
RUN	Enabled	Tx (LDO-HF Bumped, +5 dBm)	Buck ($V_{DCDC_IN}=3.6\text{ V}$)	13.1	mA
STOP	Doze	Rx (LDO-HF Bumped)	Disabled/Bypass (3.6 V)	18.2	mA
STOP	Doze	Tx (LDO-HF Bumped, +5 dBm)	Disabled/Bypass (3.6 V)	20.8	mA
RUN	Enabled	Rx (LDO-HF Bumped)	Disabled/Bypass (3.6 V)	22.6	mA
RUN	Enabled	Tx (LDO-HF Bumped, +5 dBm)	Disabled/Bypass (3.6 V)	26.6	mA

6.2.8 Designing with radiated emissions in mind

To find application notes that provide guidance on designing your system to minimize interference from radiated emissions:

1. Go to www.nxp.com
2. Perform a keyword search for “EMC design.”

6.2.9 Capacitance attributes

Table 18. Capacitance attributes

Symbol	Description	Min.	Max.	Unit
C_{IN}	Input capacitance	—	7	pF

6.3 Switching electrical specifications

6.3.1 Device clock specifications

Table 19. Device clock specifications

Symbol	Description	Min.	Max.	Unit
Normal run mode				
f_{SYS}	System and core clock	—	48	MHz
f_{BUS}	Bus clock	—	24	MHz
f_{FLASH}	Flash clock	—	24	MHz
f_{LPTMR}	LPTMR clock	—	24	MHz
VLPR and VLPS modes ¹				
f_{SYS}	System and core clock	—	4	MHz
f_{BUS}	Bus clock	—	1	MHz
f_{FLASH}	Flash clock	—	1	MHz
f_{LPTMR}	LPTMR clock ²	—	24	MHz
f_{ERCLK}	External reference clock	—	16	MHz
f_{LPTMR_ERCLK}	LPTMR external reference clock	—	16	MHz
f_{TPM}	TPM asynchronous clock	—	8	MHz
$f_{LPUART0}$	LPUART0 asynchronous clock	—	12	MHz

1. The frequency limitations in VLPR and VLPS modes here override any frequency specification listed in the timing specification for any other module. These same frequency limits apply to VLPS, whether VLPS entered from RUN or from VLPR.
2. The LPTMR can be clocked at this speed in VLPR or VLPS only when the source is an external pin.

6.3.2 General switching specifications

These general-purpose specifications apply to all signals configured for GPIO, LPUART, CAN (for KW36A only), CMT and I²C signals.

Table 20. General switching specifications

Description	Min.	Max.	Unit	Notes
GPIO pin interrupt pulse width (digital glitch filter disabled) — Synchronous path	1.5	—	Bus clock cycles	1, 2
NMI_b pin interrupt pulse width (analog filter enabled) — Asynchronous path	200	—	ns	3
GPIO pin interrupt pulse width (digital glitch filter disabled, analog filter disabled) — Asynchronous path	20	—	ns	3
External RESET_b input pulse width (digital glitch filter disabled)	100	—	ns	
Port rise and fall time(high drive strength)				4, 5
• Slew enabled	—	25	ns	
• 1.71 ≤ VDD ≤ 2.7 V	—	16	ns	
• 2.7 ≤ VDD ≤ 3.6 V				
• Slew disabled	—	8	ns	
• 1.71 ≤ VDD ≤ 2.7 V	—	6	ns	
• 2.7 ≤ VDD ≤ 3.6 V				
Port rise and fall time(low drive strength)				6, 7
• Slew enabled		24	ns	
• 1.71 ≤ VDD ≤ 2.7 V	—	16	ns	
• 2.7 ≤ VDD ≤ 3.6 V				
• Slew disabled		10	ns	
• 1.71 ≤ VDD ≤ 2.7 V	—	6	ns	
• 2.7 ≤ VDD ≤ 3.6 V				

1. This is the minimum pulse width that is guaranteed to pass through the pin synchronization circuitry in run modes.
2. The greater of synchronous and asynchronous timing must be met.
3. This is the minimum pulse width that is guaranteed to be recognized.
4. PTB0, PTB1, PTC0, PTC1, PTC2, PTC3, PTC6, PTC7, PTC17, PTC18.
5. 75 pF load.
6. Ports A, B, and C.
7. 25 pF load.

6.4 Thermal specifications

6.4.1 Thermal operating requirements

Table 21. Thermal operating requirements

Symbol	Description	Min.	Max.	Unit	Notes
T _J	Die junction temperature	−40	125	°C	
T _A	Ambient temperature	−40	105	°C	1

1. Maximum T_A can be exceeded only if the user ensures that T_J does not exceed the maximum. The simplest method to determine T_J is: $T_J = T_A + R_{\theta JA} \times \text{chip power dissipation}$.

6.4.2 Thermal attributes

Table 22. Thermal attributes

Board type	Symbol	Description	48-pin LQFN	40-pin "Wettable" HVQFN	48-pin "Wettable" HVQFN	Unit	Notes
Four-layer (2s2p)	$R_{\theta JA}$	Thermal resistance, junction to ambient (natural convection)	48.3	19.2	21.6	°C/W	1, 2
—	Ψ_{JT}	Thermal characterization parameter, junction to package top (natural convection)	0.5	0.1	0.2	°C/W	1, 3

1. Junction temperature is a function of die size, on-chip power dissipation, package thermal resistance, mounting site (board) temperature, ambient temperature, air flow, power dissipation of other components on the board, and board construction.
2. Determined according to JEDEC Standard JESD51-2A.
3. Thermal characterization parameter indicating the temperature difference between the package top and the junction temperature per JEDEC JESD51-2A.

The thermal characterization parameter (Ψ_{JT}) is used to determine the junction temperature with a measurement of the temperature at the top of the package case using the following equation:

$$T_J = T_T + \Psi_{JT} \times \text{chip power dissipation}$$

where T_T is the thermocouple temperature at the top of the package.

6.5 Peripheral operating requirements and behaviors

6.5.1 Core modules

6.5.1.1 SWD electricals

Table 23. SWD full voltage range electricals

Symbol	Description	Min.	Max.	Unit
	Operating voltage	1.71	3.6	V
J1	SWD_CLK frequency of operation <ul style="list-style-type: none"> • Serial wire debug 	0	25	MHz
J2	SWD_CLK cycle period	1/J1	—	ns

Table continues on the next page...

Table 23. SWD full voltage range electricals (continued)

Symbol	Description	Min.	Max.	Unit
J3	SWD_CLK clock pulse width • Serial wire debug	20	—	ns
J4	SWD_CLK rise and fall times	—	3	ns
J9	SWD_DIO input data setup time to SWD_CLK rise	10	—	ns
J10	SWD_DIO input data hold time after SWD_CLK rise	0	—	ns
J11	SWD_CLK high to SWD_DIO data valid	—	32	ns
J12	SWD_CLK high to SWD_DIO high-Z	5	—	ns

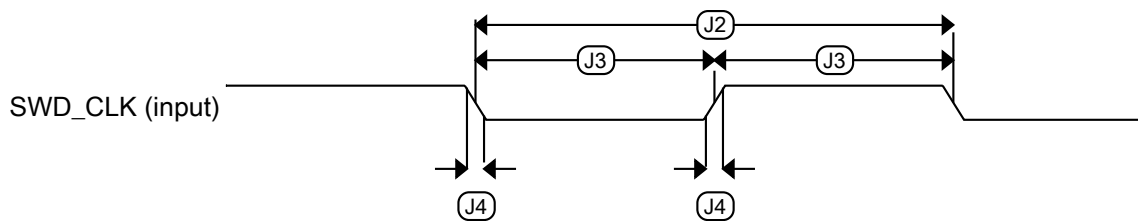

Figure 9. Serial wire clock input timing

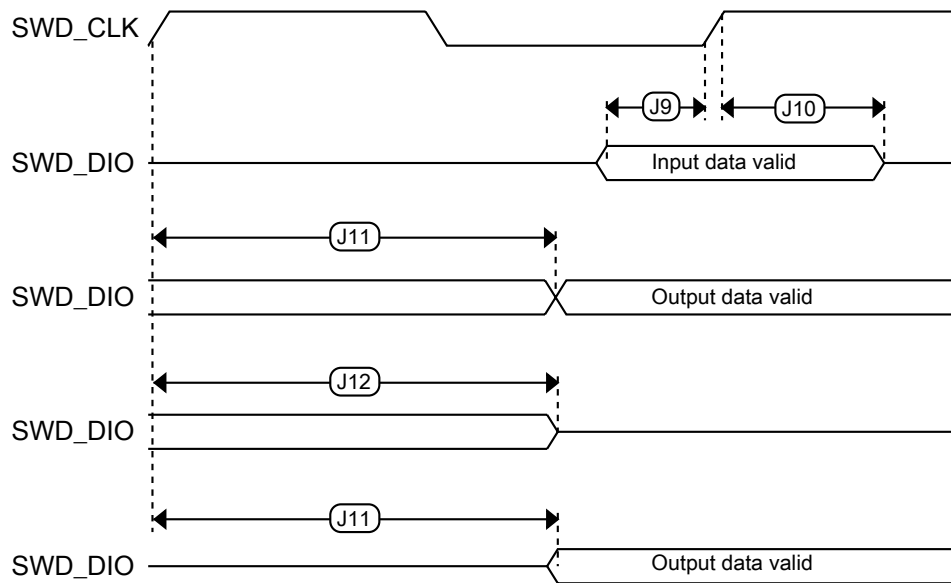

Figure 10. Serial wire data timing

6.5.2 System modules

There are no specifications necessary for the device's system modules.

6.5.3 Clock modules

6.5.3.1 MCG specifications

Table 24. MCG specifications

Symbol	Description	Min.	Typ.	Max.	Unit	Notes	
f_{ints_ft}	Internal reference frequency (slow clock) — factory trimmed at nominal V_{DD} and 25 °C	—	32.768	—	kHz		
f_{ints_t}	Internal reference frequency (slow clock) — user trimmed	31.25	—	39.0625	kHz		
$\Delta f_{dco_res_t}$	Resolution of trimmed average DCO output frequency at fixed voltage and temperature — using C3[SCTRIM] and C4[SCFTRIM]	—	± 0.3	± 0.6	% f_{dco}	1	
Δf_{dco_t}	Total deviation of trimmed average DCO output frequency over voltage and temperature	—	+0.5/−0.7	± 3	% f_{dco}	1, 2	
Δf_{dco_t}	Total deviation of trimmed average DCO output frequency over fixed voltage and temperature range of 0–70 °C	—	± 0.4	± 1.5	% f_{dco}	1, 2	
f_{intf_ft}	Internal reference frequency (fast clock) — factory trimmed at nominal V_{DD} and 25 °C	—	4	—	MHz		
Δf_{intf_ft}	Frequency deviation of internal reference clock (fast clock) over temperature and voltage — factory trimmed at nominal V_{DD} and 25 °C	—	+1/−2	± 3	% f_{intf_ft}	2	
f_{intf_t}	Internal reference frequency (fast clock) — user trimmed at nominal V_{DD} and 25 °C	3	—	5	MHz		
f_{loc_low}	Loss of external clock minimum frequency — RANGE = 00	$(3/5) \times f_{ints_t}$	—	—	kHz		
f_{loc_high}	Loss of external clock minimum frequency — RANGE = 01, 10, or 11	$(16/5) \times f_{ints_t}$	—	—	kHz		
FLL							
f_{fill_ref}	FLL reference frequency range	31.25	—	39.0625	kHz		
f_{dco}	DCO output frequency range	Low range (DRS = 00) $640 \times f_{fill_ref}$	20	20.97	25	MHz	3, 4
		Mid range (DRS = 01) $1280 \times f_{fill_ref}$	40	41.94	48	MHz	
$f_{dco_t_DMX3}$ 2	DCO output frequency	Low range (DRS = 00) $732 \times f_{fill_ref}$	—	23.99	—	MHz	5, 6
		Mid range (DRS = 01) $1464 \times f_{fill_ref}$	—	47.97	—	MHz	

Table continues on the next page...

Table 24. MCG specifications (continued)

Symbol	Description	Min.	Typ.	Max.	Unit	Notes
J_{cyc_fll}	FLL period jitter • $f_{VCO} = 48$ MHz	—	180	—	ps	7
$t_{fll_acquire}$	FLL target frequency acquisition time	—	—	1	ms	8

1. This parameter is measured with the internal reference (slow clock) being used as a reference to the FLL (FEI clock mode).
2. The deviation is relative to the factory trimmed frequency at nominal V_{DD} and 25 °C, f_{ints_ft} .
3. These typical values listed are with the slow internal reference clock (FEI) using factory trim and DMX32 = 0.
4. The resulting system clock frequencies must not exceed their maximum specified values. The DCO frequency deviation (Δf_{dco_t}) over voltage and temperature must be considered.
5. These typical values listed are with the slow internal reference clock (FEI) using factory trim and DMX32 = 1.
6. The resulting clock frequency must not exceed the maximum specified clock frequency of the device.
7. This specification is based on standard deviation (RMS) of period or frequency.
8. This specification applies to any time the following changes: FLL reference source or reference divider, trim value, DMX32 bit, DRS bits, or FLL disabled (BLPE, BLPI) to FLL enabled (FEI, FEE, FBE, FBI). If a crystal/resonator is used as the reference, this specification assumes it is already running.

6.5.3.2 Reference Oscillator Specification

The KW36A/35A/34A has been designed to meet targeted standard specifications for frequency error over the life of the part, which includes the temperature, mechanical and aging effects.

The table below lists the recommended crystal specifications. Note that these are recommendations only and deviation may be allowed. However, deviations may result in degraded RF performance or possibly a failure to meet RF protocol certification standards. Designers must ensure that the crystal(s) they use meet the requirements of their application.

Table 25. Recommended Crystal and Oscillator Specification

Symbol	Description	F0 = 32.0 MHz			F0 = 26.0 MHz			Unit	Notes
		Min	Typ	Max	Min	Typ	Max		
T_A	Operating Temperature	-40	—	105	-40	—	105	°C	1
	Crystal initial frequency tolerance	-10	—	10	-10	—	10	ppm	2,3
	Crystal frequency stability and aging	-25	—	25	-25	—	24	ppm	2,4
	Oscillator variation	-12	—	15	-12	—	16	ppm	5
	Total reference oscillator tolerance	-50	—	50	-50	—	50	ppm	6

Table continues on the next page...

Table 25. Recommended Crystal and Oscillator Specification (continued)

Symbol	Description	F0 = 32.0 MHz			F0 = 26.0 MHz			Unit	Notes
		Min	Typ	Max	Min	Typ	Max		
	for Bluetooth LE applications								
C _L	Load capacitance	7	10	13	7	10	13	pF	2, 7
C ₀	Shunt capacitance	0.469	0.67	0.871	0.42	0.6	0.78	pF	2,7
C _{m1}	Motional capacitance	1.435	2.05	2.665	1.435	2.05	2.665	fF	2,7
L _{m1}	Motional inductance	8.47	12.1	15.73	12.81	18.3	23.79	mH	2,7
R _{m1}	Motional resistance	—	25	50	—	35	50	Ohms	2
ESR	Equivalent series resistance	—	—	60	—	—	60	Ohms	2,8
P _d	Maximum crystal drive	—	10	200	—	10	200	uW	2
T _S	Trim sensitivity	6.30	9.00	11.70	6.39	9.12	11.86	ppm/pF	2,7
T _{OSC}	Oscillator Startup Time	—	500	—	—	500	—	μs	9

1. Full temperature range of this device. A reduced range can be chosen to meet application needs.
2. Recommended crystal specification.
3. Measured at 25 °C.
4. Combination of frequency stability variation over desired temperature range and frequency variation due to aging over desired lifetime of system.
5. Variation due to temperature, process, and aging of MCU.
6. Sum of crystal initial frequency tolerance, crystal frequency stability and aging, oscillator variation, and PCB manufacturing variation must not exceed this value.
7. Typical is target. 30% tolerances shown.
8. $ESR = R_{m1} * (1 + [C_0/C_L])^2$.
9. Time from oscillator enable to clock ready. Dependent on the complete hardware configuration of the oscillator.



Figure 11. Crystal Electrical Model

6.5.3.3 32 kHz Oscillator Frequency Specifications

Table 26. 32 kHz Crystal and Oscillator Specifications

Symbol	Description	Min.	Typ.	Max.	Unit	Notes
f_{osc_lo}	Crystal frequency	—	32.768	—	kHz	
T_A	Operating temperature	-40	—	105	°C	1
	Total crystal frequency tolerance	-500	—	500	ppm	2,3
C_L	Load capacitance	—	12.5	—	pF	2
ESR	Equivalent series resistance	—	—	80	kOhms	2
t_{start}	Crystal start-up time	—	1000	—	ms	4
$f_{ec_extal32}$	External input clock frequency	—	32.768	—	kHz	5
$V_{ec_extal32}$	External input clock amplitude	0.7	—	V_{DD}	V	6

1. Full temperature range of this device. A reduced range can be chosen to meet application needs.
2. Recommended crystal specification.

3. Sum of crystal initial frequency tolerance, crystal frequency stability, and aging tolerances given by crystal vendor.
4. Time from oscillator enable to clock stable. Dependent on the complete hardware configuration of the oscillator.
5. External oscillator connected to EXTAL32K. XTAL32K must be unconnected.
6. The parameter specified is a peak-to-peak value and V_{IH} and V_{IL} specifications do not apply. The voltage of the applied clock must be within the range of VSS to VDD.

6.5.4 Memories and memory interfaces

6.5.4.1 Flash (FTFE) electrical specifications

This section describes the electrical characteristics of the FTFE module.

6.5.4.1.1 Flash timing specifications — commands

Table 27. Flash command timing specifications

Symbol	Description ¹	Min.	Typ.	Max.	Unit	Notes
$t_{rd1blk256k}$	Read 1s Block execution time • 256 KB program/data flash	—	—	2	ms	
$t_{rd1sec2k}$	Read 1s Section execution time (2 KB flash)	—	—	75	μ s	
t_{pgmchk}	Program Check execution time	—	—	95	μ s	
t_{rdsrc}	Read Resource execution time	—	—	40	μ s	
t_{pgm8}	Program Phrase execution time	—	90	225	μ s	
$t_{ersblk256k}$	Erase Flash Block execution time • 256 KB program/data flash	—	125	2125	ms	2
t_{ersscr}	Erase Flash Sector execution time	—	12	130	ms	2
$t_{pgmsec2k}$	Program Section execution time (2 KB flash)	—	10	—	ms	
$t_{rd1allx}$	Read 1s All Blocks execution time • FlexNVM devices	—	—	3.5	ms	
$t_{rd1alln}$	• Program flash only devices	—	—	3.5	ms	
t_{rdonce}	Read Once execution time	—	—	30	μ s	
$t_{pgmonce}$	Program Once execution time	—	90	—	μ s	
t_{ersall}	Erase All Blocks execution time	—	262	4380	ms	2
t_{vfykey}	Verify Backdoor Access Key execution time	—	—	35	μ s	
$t_{ersallu}$	Erase All Blocks Unsecure execution time	—	262	4380	ms	2
$t_{swapx01}$	Swap Control execution time • control code 0x01	—	280	—	μ s	
$t_{swapx02}$	• control code 0x02	—	100	235	μ s	
$t_{swapx04}$	• control code 0x04	—	100	235	μ s	
$t_{swapx08}$		—	—	35	μ s	

Table continues on the next page...

Table 27. Flash command timing specifications (continued)

Symbol	Description ¹	Min.	Typ.	Max.	Unit	Notes
t _{swapx10}	<ul style="list-style-type: none"> control code 0x08 control code 0x10 	—	100	235	µs	
t _{pgmpart32k}	Program Partition for EEPROM execution time	—	252	—	ms	
t _{pgmpart256k}	<ul style="list-style-type: none"> 32 KB EEPROM backup 256 KB EEPROM backup 	—	262	—	ms	
t _{setramff}	Set FlexRAM Function execution time:	—	115	—	µs	
t _{setram32k}	<ul style="list-style-type: none"> Control Code 0xFF 32 KB EEPROM backup 	—	0.8	1.2	ms	
t _{setram256k}	<ul style="list-style-type: none"> 256 KB EEPROM backup 	—	4.5	6.1	ms	
t _{eewr8b32k}	Byte-write to FlexRAM execution time:	—	385	1700	µs	3
t _{eewr8b256k}	<ul style="list-style-type: none"> 32 KB EEPROM backup 256 KB EEPROM backup 	—	1015	3800	µs	
t _{eewr16b32k}	16-bit write to FlexRAM execution time:	—	385	1700	µs	3
t _{eewr16b256k}	<ul style="list-style-type: none"> 32 KB EEPROM backup 256 KB EEPROM backup 	—	1015	3800	µs	
t _{eewr32bers}	32-bit write to erased FlexRAM location execution time	—	360	2000	µs	3
t _{eewr32b32k}	32-bit write to FlexRAM execution time:	—	630	2000	µs	3
t _{eewr32b256k}	<ul style="list-style-type: none"> 32 KB EEPROM backup 256 KB EEPROM backup 	—	1890	4100	µs	

1. All command times assume 25 MHz or greater flash clock frequency (for synchronization time between internal/external clocks).
2. Maximum times for erase parameters based on expectations at cycling end-of-life.
3. First time EERAM writes after a Reset or SETRAM command may incur additional overhead for EEE cleanup, resulting in up to 2x the times shown.

NOTE

Under certain circumstances maximum times for writes to FlexRAM may be exceeded. In this case the user or application may wait, or assert reset to the FTFE module to stop the operation.

6.5.4.1.2 Reliability specifications

Table 28. NVM reliability specifications

Symbol	Description	Min.	Typ.	Max.	Unit	Notes
Program Flash						

Table continues on the next page...

Table 28. NVM reliability specifications (continued)

Symbol	Description	Min.	Typ.	Max.	Unit	Notes
t_{nvmet1k}	Data retention after up to 1 K cycles	20	—	—	years	1
n_{nvmcyc}	Cycling endurance	1 K	—	—	cycles	2
FlexRAM as Emulated EEPROM						
t_{nvmetee}	Data retention	5	—	—	years	1, 3
	Write endurance					4, 5, 6
$n_{\text{nvmwree16}}$	• EEPROM backup to FlexRAM used ratio = 16	100 K	—	—	writes	
$n_{\text{nvmwree256}}$	• EEPROM backup to FlexRAM used ratio = 256	1.6 M	—	—	writes	

1. Data retention period per block begins upon initial user factory programming or after each subsequent erase.
2. Program and Erase are supported across product temperature specification. Cycling endurance is per flash sector.
3. Background maintenance operations during normal FlexRAM usage extend effective data retention life beyond 5 years.
4. FlexMemory write endurance specified for 16-bit and/or 32-bit writes to FlexRAM and is supported across product temperature specification. Greater write endurance may be achieved with larger ratios of EEPROM backup to FlexRAM.
5. For usage of any EEE driver other than the FlexMemory feature, the endurance specification falls back to the Data Flash endurance value of 1 K.
6. [FlexMemory calculator tool](#) is available on the NXP web site for help in estimating the maximum write endurance achievable at specific EEPROM/FlexRAM ratios. The "In Spec" portions of the online calculator refer to the NVM reliability specifications section of the data sheet. This calculator only applies to the Kinetis FlexMemory feature.

6.5.4.1.3 Write endurance to FlexRAM for EEPROM

When the FlexNVM partition code is not set to full data flash, the EEPROM data set size can be set to any of several non-zero values.

The bytes not assigned to data flash via the FlexNVM partition code are used by the FTFE to obtain an effective endurance increase for the EEPROM data. The built-in EEPROM record management system raises the number of program/erase cycles that can be attained prior to device wear-out by cycling the EEPROM data through a larger EEPROM NVM storage space.

While different partitions of the FlexNVM are available, the intention is that a single choice for the FlexNVM partition code and EEPROM data set size is used throughout the entire lifetime of a given application.

6.5.5 Security and integrity modules

There are no specifications necessary for the device's security and integrity modules.

6.5.6 Analog

6.5.6.1 ADC electrical specifications

All other ADC channels meet the 13-bit differential/12-bit single-ended accuracy specifications. The following specification is defined with the DC-DC converter operating in Bypass mode.

6.5.6.1.1 16-bit ADC operating conditions

Table 29. 16-bit ADC operating conditions

Symbol	Description	Conditions	Min.	Typ. ¹	Max.	Unit	Notes
V _{DDA}	Supply voltage	Absolute	1.71	—	3.6	V	
ΔV _{DDA}	Supply voltage	Delta to V _{DD} (V _{DD} – V _{DDA})	–100	0	+100	mV	2
ΔV _{SSA}	Ground voltage	Delta to V _{SS} (V _{SS} – V _{SSA})	–100	0	+100	mV	2
V _{REFH}	ADC reference voltage high		1.13	V _{DDA}	V _{DDA}	V	3
V _{REFL}	ADC reference voltage low		V _{SSA}	V _{SSA}	V _{SSA}	V	3
V _{ADIN}	Input voltage	<ul style="list-style-type: none"> 16-bit differential mode All other modes 	V _{SSA} V _{SSA}	— —	31/32 × V _{REFH} V _{REFH}	V	
C _{ADIN}	Input capacitance	<ul style="list-style-type: none"> 16-bit mode 8-bit / 10-bit / 12-bit modes 	— —	8 4	10 5	pF	
R _{ADIN}	Input series resistance		—	2	5	kΩ	
R _{AS}	Analog source resistance (external)	13-bit / 12-bit modes f _{ADCK} < 4 MHz	—	—	5	kΩ	4
f _{ADCK}	ADC conversion clock frequency	≤ 13-bit mode	1.0	—	18.0	MHz	5
f _{ADCK}	ADC conversion clock frequency	16-bit mode	2.0	—	12.0	MHz	5
C _{rate}	ADC conversion rate	≤ 13-bit modes No ADC hardware averaging Continuous conversions enabled, subsequent conversion time	20.000	—	818.330	kS/s	6
C _{rate}	ADC conversion rate	16-bit mode No ADC hardware averaging	37.037	—	461.467	kS/s	6

Table 29. 16-bit ADC operating conditions

Symbol	Description	Conditions	Min.	Typ. ¹	Max.	Unit	Notes
		Continuous conversions enabled, subsequent conversion time					

1. Typical values assume $V_{DDA} = 3.0\text{ V}$, $\text{Temp} = 25\text{ }^\circ\text{C}$, $f_{\text{ADCK}} = 1.0\text{ MHz}$, unless otherwise stated. Typical values are for reference only, and are not tested in production.
2. DC potential difference.
3. For packages without dedicated V_{REFH} and V_{REFL} pins, V_{REFH} is internally tied to V_{DDA} , and V_{REFL} is internally tied to V_{SSA} .
4. This resistance is external to MCU. To achieve the best results, the analog source resistance must be kept as low as possible. The results in this data sheet are derived from a system that had $< 8\ \Omega$ analog source resistance. The $R_{\text{AS}}/C_{\text{AS}}$ time constant should be kept to $< 1\text{ ns}$.
5. To use the maximum ADC conversion clock frequency, $\text{CFG2}[\text{ADHSC}]$ must be set and $\text{CFG1}[\text{ADLPC}]$ must be clear.
6. For guidelines and examples of conversion rate calculation, download the [ADC calculator tool](#).



Figure 12. ADC input impedance equivalency diagram

6.5.6.1.2 16-bit ADC electrical characteristics

Table 30. 16-bit ADC characteristics ($V_{REFH} = V_{DDA}$, $V_{REFL} = V_{SSA}$)

Symbol	Description	Conditions ¹	Min.	Typ. ²	Max.	Unit	Notes
I_{DDA_ADC}	Supply current		0.215	—	1.7	mA	3
f_{ADACK}	ADC asynchronous clock source	<ul style="list-style-type: none"> ADLPC=1, ADHSC=0 ADLPC=1, ADHSC=1 ADLPC=0, ADHSC=0 ADLPC=0, ADHSC=1 	1.2 2.4 3.0 4.4	2.4 4.0 5.2 6.2	3.9 6.1 7.3 9.5	MHz	$t_{ADACK} = 1/f_{ADACK}$
	Sample Time	See Reference Manual chapter for sample times					
TUE	Total unadjusted error	<ul style="list-style-type: none"> 12-bit modes <12-bit modes 	— —	± 4 ± 1.4	± 6.8 ± 2.1	LSB ⁴	5
DNL	Differential non-linearity	<ul style="list-style-type: none"> 12-bit mode; Buck Mode⁶ 12-bit mode; Bypass Mode 	— —	± 0.7 ± 0.5	-1.1 to +1.9 -1.1 to +1.9	LSB ⁴	5
INL	Integral non-linearity	<ul style="list-style-type: none"> 12-bit mode; Buck Mode⁶ 12-bit mode; Bypass Mode 	— —	± 1.0 ± 0.6	-2.7 to +1.9 -2.7 to +1.9	LSB ⁴	5
E_{FS}	Full-scale error	<ul style="list-style-type: none"> 12-bit modes <12-bit modes 	— —	-4 -1.4	-5.4 -1.8	LSB ⁴	$V_{ADIN} = V_{DDA}$ ⁵
E_Q	Quantization error	<ul style="list-style-type: none"> 16-bit modes ≤ 13-bit modes 	— —	-1 to 0 —	— ± 0.5	LSB ⁴	
ENOB	Effective number of bits	16-bit differential mode; Buck Mode ⁶ <ul style="list-style-type: none"> Avg = 32 Avg = 4 16-bit single-ended mode; Buck Mode ⁶ <ul style="list-style-type: none"> Avg = 32 Avg = 4 16-bit differential mode; Bypass Mode <ul style="list-style-type: none"> Avg = 32 Avg = 4 16-bit single-ended mode; Bypass Mode <ul style="list-style-type: none"> Avg = 32 Avg = 4 	12 11.25 11 9.5 12.5 11.25 11 10	12.75 11.75 11.5 10.5 13 12 11.75 10.5	— — — — — — — —	bits	7
SINAD	Signal-to-noise plus distortion	See ENOB	$6.02 \times \text{ENOB} + 1.76$			dB	
THD	Total harmonic distortion	16-bit differential mode; Buck Mode ⁶					8

Table continues on the next page...

Table 30. 16-bit ADC characteristics ($V_{REFH} = V_{DDA}$, $V_{REFL} = V_{SSA}$) (continued)

Symbol	Description	Conditions ¹	Min.	Typ. ²	Max.	Unit	Notes
		<ul style="list-style-type: none"> Avg = 32 16-bit single-ended mode; Buck Mode ⁶	—	–90	—	dB	
		<ul style="list-style-type: none"> Avg = 32 16-bit differential mode; Bypass Mode	—	–88	—		
		<ul style="list-style-type: none"> Avg = 32 16-bit single-ended mode; Bypass Mode	—	–89	—		
		<ul style="list-style-type: none"> Avg = 32 16-bit single-ended mode; Bypass Mode	—	–87	—		
SINAD	Signal-to-noise plus distortion	See ENOB	6.02 × ENOB + 1.76			dB	
SFDR	Spurious free dynamic range distortion	16-bit differential mode; Buck Mode ⁶	85	89	—	dB	8
		<ul style="list-style-type: none"> Avg = 32 16-bit single-ended mode; Buck Mode ⁶					
		<ul style="list-style-type: none"> Avg = 32 16-bit differential mode; Bypass Mode					
		<ul style="list-style-type: none"> Avg = 32 16-bit single-ended mode; Bypass Mode					
E _{IL}	Input leakage error		$I_{in} \times R_{AS}$			mV	I_{in} = leakage current (see Voltage and current operating ratings)
	Temp sensor slope	Across the full temperature range of the device	1.67	1.74	1.81	mV/°C	9
V _{TEMP25}	Temp sensor voltage	25 °C	706	716	726	mV	9

1. All accuracy numbers assume that the ADC is calibrated with $V_{REFH} = V_{DDA}$.

2. Typical values assume $V_{DDA} = 3.0$ V, Temp = 25 °C, $f_{ADCK} = 2.0$ MHz unless otherwise stated. Typical values are for reference only and are not tested in production.

KW36A/35A/34A Electrical Characteristics

- The ADC supply current depends on the ADC conversion clock speed, conversion rate and ADC_CFG1[ADLPC] (low-power). For lowest power operation, ADC_CFG1[ADLPC] must be set, the ADC_CFG2[ADHSC] bit must be clear with 1 MHz ADC conversion clock speed.
- $1 \text{ LSB} = (V_{\text{REFH}} - V_{\text{REFL}})/2^N$.
- ADC conversion clock < 16 MHz, maximum hardware averaging (AVGE = %1, AVGS = %11).
- VREFH = Output of Voltage Reference(VREF).
- Input data is 100 Hz sine wave. ADC conversion clock < 12 MHz.
- Input data is 1 kHz sine wave. ADC conversion clock < 12 MHz.
- ADC conversion clock < 3 MHz.

6.5.6.2 Voltage reference electrical specifications

Table 31. VREF full-range operating requirements

Symbol	Description	Min.	Max.	Unit	Notes
V _{DDA}	Supply voltage	1.71	3.6	V	
T _A	Temperature	-40 to 105		°C	
C _L	Output load capacitance	100		nF	1, 2

- C_L must be connected to VREF_OUT if the VREF_OUT functionality is being used for either an internal or external reference.
- The load capacitance should not exceed +/-25% of the nominal specified C_L value over the operating temperature range of the device.

Table 32. VREF full-range operating behaviors

Symbol	Description	Min.	Typ.	Max.	Unit	Notes
V _{out}	Voltage reference output with factory trim at nominal V _{DDA} and temperature=25 °C	1.190	1.1950	1.2	V	1
V _{out}	Voltage reference output with user trim at nominal V _{DDA} and temperature=25 °C	1.1945	1.1950	1.1955	V	1
V _{step}	Voltage reference trim step	—	0.5	—	mV	1
V _{tdrift}	Temperature drift (V _{max} -V _{min} across the full temperature range)	—	—	20	mV	1
I _{bg}	Bandgap only current	—	—	80	µA	
I _{lp}	Low-power buffer current	—	—	360	uA	1
I _{hp}	High-power buffer current	—	—	1	mA	1
ΔV _{LOAD}	Load regulation • current = ± 1.0 mA	—	200	—	µV	1, 2
T _{stup}	Buffer startup time	—	—	100	µs	
T _{chop_osc_st} up	Internal bandgap start-up delay with chop oscillator enabled	—	—	35	ms	
V _{vdrift}	Voltage drift (V _{max} -V _{min} across the full voltage range)	—	2	—	mV	1

- See the chip's Reference Manual for the appropriate settings of the VREF Status and Control register.
- Load regulation voltage is the difference between the VREF_OUT voltage with no load vs. voltage with defined load

Table 33. VREF limited-range operating requirements

Symbol	Description	Min.	Max.	Unit	Notes
T_A	Temperature	0	70	°C	

Table 34. VREF limited-range operating behaviors

Symbol	Description	Min.	Max.	Unit	Notes
V_{tdrift}	Temperature drift ($V_{max} - V_{min}$ across the limited temperature range)	—	15	mV	

6.5.6.3 CMP and 6-bit DAC electrical specifications

Table 35. Comparator and 6-bit DAC electrical specifications

Symbol	Description	Min.	Typ.	Max.	Unit
V_{DD}	Supply voltage	1.71	—	3.6	V
I_{DDHS}	Supply current, High-speed mode (EN=1, PMODE=1)	—	—	200	μA
$I_{DDL S}$	Supply current, low-speed mode (EN=1, PMODE=0)	—	—	20	μA
V_{AIN}	Analog input voltage	$V_{SS} - 0.3$	—	V_{DD}	V
V_{AIO}	Analog input offset voltage	—	—	20	mV
V_H	Analog comparator hysteresis ¹ <ul style="list-style-type: none"> • CR0[HYSTCTR] = 00 • CR0[HYSTCTR] = 01 • CR0[HYSTCTR] = 10 • CR0[HYSTCTR] = 11 	—	5 10 20 30	—	mV mV mV mV
V_{CMPOH}	Output high	$V_{DD} - 0.5$	—	—	V
V_{CMPOI}	Output low	—	—	0.5	V
t_{DHS}	Propagation delay, high-speed mode (EN=1, PMODE=1)	20	50	200	ns
t_{DLS}	Propagation delay, low-speed mode (EN=1, PMODE=0)	80	250	600	ns
	Analog comparator initialization delay ²	—	—	40	μs
I_{DAC6b}	6-bit DAC current adder (enabled)	—	7	—	μA
INL	6-bit DAC integral non-linearity	-0.5	—	0.5	LSB ³
DNL	6-bit DAC differential non-linearity	-0.3	—	0.3	LSB

1. Typical hysteresis is measured with input voltage range limited to 0.6 to $V_{DD} - 0.6$ V.
2. Comparator initialization delay is defined as the time between software writes to change control inputs (Writes to CMP_DACCR[DACEN], CMP_DACCR[VRSEL], CMP_DACCR[VOSEL], CMP_MUXCR[PSEL], and CMP_MUXCR[MSEL]) and the comparator output settling to a stable level.
3. 1 LSB = $V_{reference}/64$



Figure 13. Typical hysteresis vs. Vin level (VDD = 3.3 V, PMODE = 0)

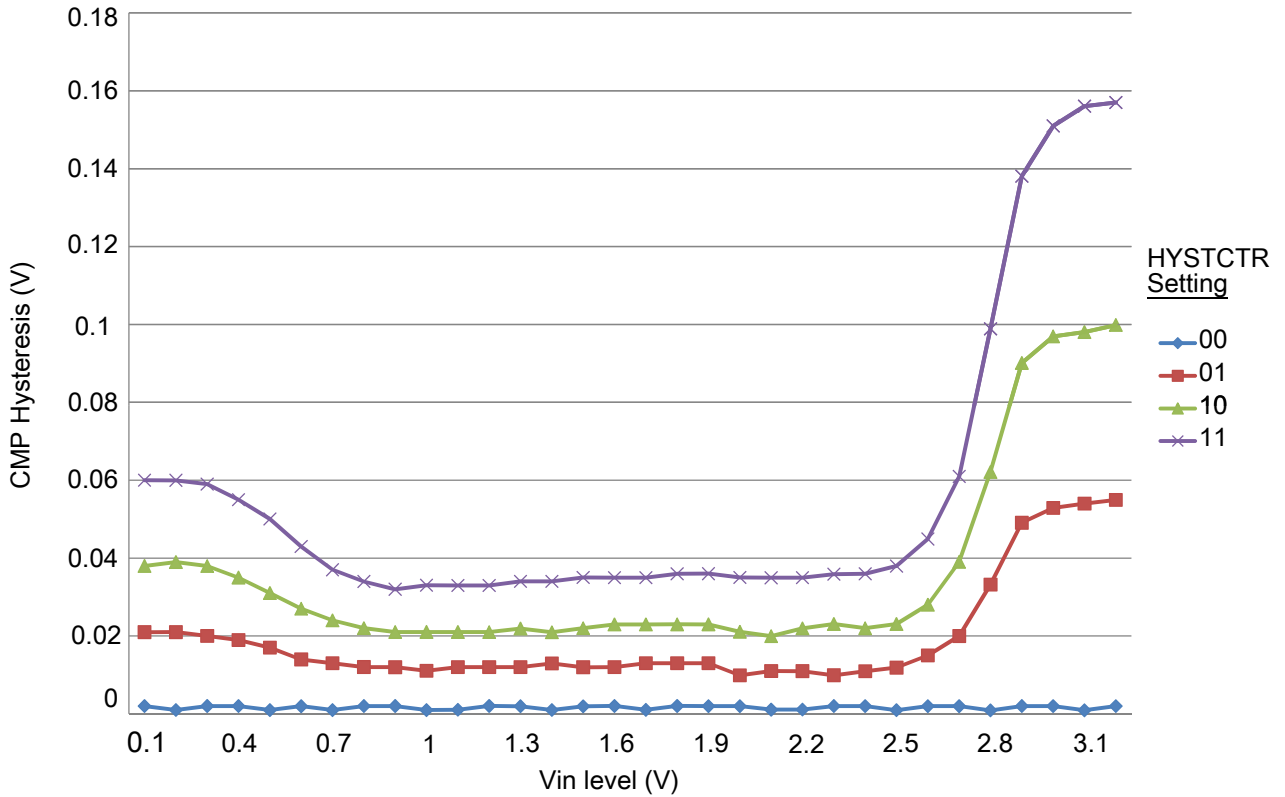

Figure 14. Typical hysteresis vs. Vin level (VDD = 3.3 V, PMODE = 1)

6.5.7 Timers

See [General switching specifications](#).

6.5.8 Communication interfaces

6.5.8.1 CAN switching specifications

See [General switching specifications](#).

6.5.8.2 DSPI switching specifications (limited voltage range)

The DMA Serial Peripheral Interface (DSPI) provides a synchronous serial bus with master and slave operations. Many of the transfer attributes are programmable. The tables below provide DSPI timing characteristics for classic SPI timing modes. See the DSPI chapter of the Reference Manual for information on the modified transfer formats used for communicating with slower peripheral devices.

Table 36. Master mode DSPI timing (limited voltage range)

Num	Description	Min.	Max.	Unit	Notes
	Operating voltage	2.7	3.6	V	
	Frequency of operation	—	12	MHz	
DS1	DSPI_SCK output cycle time	$2 \times t_{BUS}$	—	ns	
DS2	DSPI_SCK output high/low time	$(t_{SCK}/2) - 2$	$(t_{SCK}/2) + 2$	ns	
DS3	DSPI_PCSn valid to DSPI_SCK delay	$(t_{BUS} \times 2) - 2$	—	ns	1
DS4	DSPI_SCK to DSPI_PCSn invalid delay	$(t_{BUS} \times 2) - 2$	—	ns	2
DS5	DSPI_SCK to DSPI_SOUT valid	—	8.5	ns	
DS6	DSPI_SCK to DSPI_SOUT invalid	-2	—	ns	
DS7	DSPI_SIN to DSPI_SCK input setup	16.2	—	ns	
DS8	DSPI_SCK to DSPI_SIN input hold	0	—	ns	

1. The delay is programmable in SPIx_CTARn[PCSSCK] and SPIx_CTARn[CSSCK].
2. The delay is programmable in SPIx_CTARn[PASC] and SPIx_CTARn[ASC].

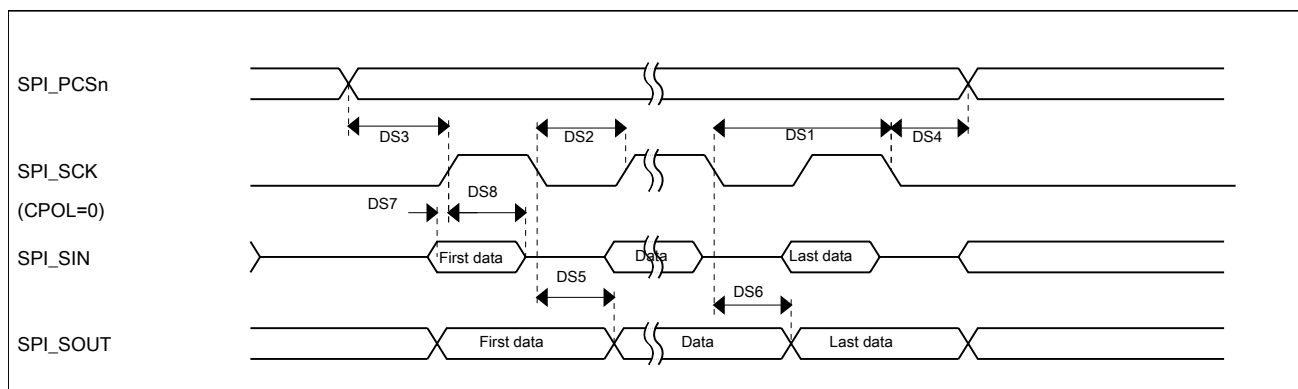

Figure 15. DSPI classic SPI timing — master mode

Table 37. Slave mode DSPI timing (limited voltage range)

Num	Description	Min.	Max.	Unit
	Operating voltage	2.7	3.6	V
	Frequency of operation		6	MHz

Table continues on the next page...

Table 37. Slave mode DSPI timing (limited voltage range) (continued)

Num	Description	Min.	Max.	Unit
DS9	DSPI_SCK input cycle time	4 x t _{BUS}	—	ns
DS10	DSPI_SCK input high/low time	(t _{SCK/2}) - 2	(t _{SCK/2}) + 2	ns
DS11	DSPI_SCK to DSPI_SOUT valid	—	21.4	ns
DS12	DSPI_SCK to DSPI_SOUT invalid	0	—	ns
DS13	DSPI_SIN to DSPI_SCK input setup	2.6	—	ns
DS14	DSPI_SCK to DSPI_SIN input hold	7.0	—	ns
DS15	DSPI_SS active to DSPI_SOUT driven	—	14	ns
DS16	DSPI_SS inactive to DSPI_SOUT not driven	—	14	ns

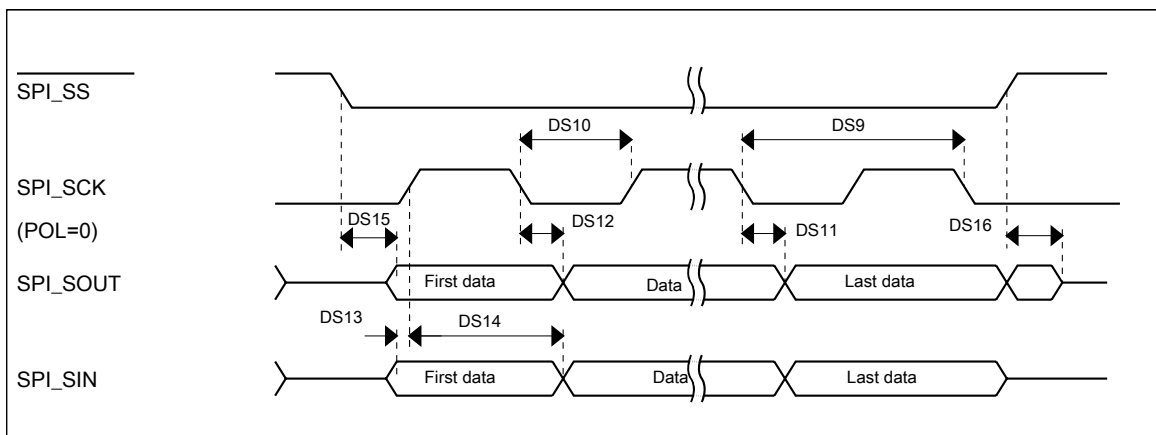

Figure 16. DSPI classic SPI timing — slave mode

6.5.8.3 DSPI switching specifications (full voltage range)

The DMA Serial Peripheral Interface (DSPI) provides a synchronous serial bus with master and slave operations. Many of the transfer attributes are programmable. The tables below provide DSPI timing characteristics for classic SPI timing modes. See the DSPI chapter of the Reference Manual for information on the modified transfer formats used for communicating with slower peripheral devices.

Table 38. Master mode DSPI timing (full voltage range)

Num	Description	Min.	Max.	Unit	Notes
	Operating voltage	1.71	3.6	V	1
	Frequency of operation	—	12	MHz	
DS1	DSPI_SCK output cycle time	2 x t _{BUS}	—	ns	
DS2	DSPI_SCK output high/low time	(t _{SCK/2}) - 4	(t _{SCK/2}) + 4	ns	

Table continues on the next page...

Table 38. Master mode DSPI timing (full voltage range) (continued)

Num	Description	Min.	Max.	Unit	Notes
DS3	DSPI_PCSn valid to DSPI_SCK delay	$(t_{BUS} \times 2) - 4$	—	ns	2
DS4	DSPI_SCK to DSPI_PCSn invalid delay	$(t_{BUS} \times 2) - 4$	—	ns	3
DS5	DSPI_SCK to DSPI_SOUT valid	—	10	ns	
DS6	DSPI_SCK to DSPI_SOUT invalid	-1.2	—	ns	
DS7	DSPI_SIN to DSPI_SCK input setup	23.3	—	ns	
DS8	DSPI_SCK to DSPI_SIN input hold	0	—	ns	

1. The DSPI module can operate across the entire operating voltage for the processor, but to run across the full voltage range the maximum frequency of operation is reduced.
2. The delay is programmable in SPIx_CTARn[PCSSCK] and SPIx_CTARn[CSSCK].
3. The delay is programmable in SPIx_CTARn[PASC] and SPIx_CTARn[ASC].



Figure 17. DSPI classic SPI timing — master mode

Table 39. Slave mode DSPI timing (full voltage range)

Num	Description	Min.	Max.	Unit
	Operating voltage	1.71	3.6	V
	Frequency of operation	—	6	MHz
DS9	DSPI_SCK input cycle time	$4 \times t_{BUS}$	—	ns
DS10	DSPI_SCK input high/low time	$(t_{SCK}/2) - 4$	$(t_{SCK}/2) + 4$	ns
DS11	DSPI_SCK to DSPI_SOUT valid	—	29.1	ns
DS12	DSPI_SCK to DSPI_SOUT invalid	0	—	ns
DS13	DSPI_SIN to DSPI_SCK input setup	3.2	—	ns
DS14	DSPI_SCK to DSPI_SIN input hold	7.0	—	ns
DS15	$\overline{DSPI_SS}$ active to DSPI_SOUT driven	—	25	ns
DS16	$\overline{DSPI_SS}$ inactive to DSPI_SOUT not driven	—	25	ns



Figure 18. DSPI classic SPI timing — slave mode

6.5.8.4 Inter-Integrated Circuit Interface (I²C) timing

Table 40. I²C timing

Characteristic	Symbol	Standard Mode		Fast Mode		Unit
		Minimum	Maximum	Minimum	Maximum	
SCL Clock Frequency	f _{SCL}	0	100	0	400	kHz
Hold time (repeated) START condition. After this period, the first clock pulse is generated.	t _{HD} ; STA	4	—	0.6	—	μs
LOW period of the SCL clock	t _{LOW}	4.7	—	1.3	—	μs
HIGH period of the SCL clock	t _{HIGH}	4	—	0.6	—	μs
Set-up time for a repeated START condition	t _{SU} ; STA	4.7	—	0.6	—	μs
Data hold time for I ² C bus devices	t _{HD} ; DAT	0 ¹	3.45 ²	0 ³	0.9 ¹	μs
Data set-up time	t _{SU} ; DAT	250 ⁴	—	100 ^{2, 5}	—	ns
Rise time of SDA and SCL signals	t _r	—	1000	20 + 0.1C _b ^{5, 6}	300	ns
Fall time of SDA and SCL signals	t _f	—	300	20 + 0.1C _b ^{5, 6}	300	ns
Set-up time for STOP condition	t _{SU} ; STO	4	—	0.6	—	μs
Bus free time between STOP and START condition	t _{BUF}	4.7	—	1.3	—	μs
Pulse width of spikes that must be suppressed by the input filter	t _{SP}	N/A	N/A	0	50	ns

1. The master mode I²C deasserts ACK of an address byte simultaneously with the falling edge of SCL. If no slaves acknowledge this address byte, then a negative hold time can result, depending on the edge rates of the SDA and SCL lines.
2. The maximum t_{HD}; DAT must be met only if the device does not stretch the LOW period (t_{LOW}) of the SCL signal.
3. Input signal Slew = 10 ns and Output Load = 50 pF.
4. Set-up time in slave-transmitter mode is 1 IP Bus clock period, if the TX FIFO is empty.

KW36A/35A/34A Electrical Characteristics

- A Fast mode I²C bus device can be used in a Standard mode I²C bus system, but the requirement $t_{SU; DAT} \geq 250$ ns must then be met. This is automatically the case if the device does not stretch the LOW period of the SCL signal. If such a device does stretch the LOW period of the SCL signal, then it must output the next data bit to the SDA line $t_{rmax} + t_{SU; DAT} = 1000 + 250 = 1250$ ns (according to the Standard mode I²C bus specification) before the SCL line is released.
- C_b = total capacitance of the one bus line in pF.

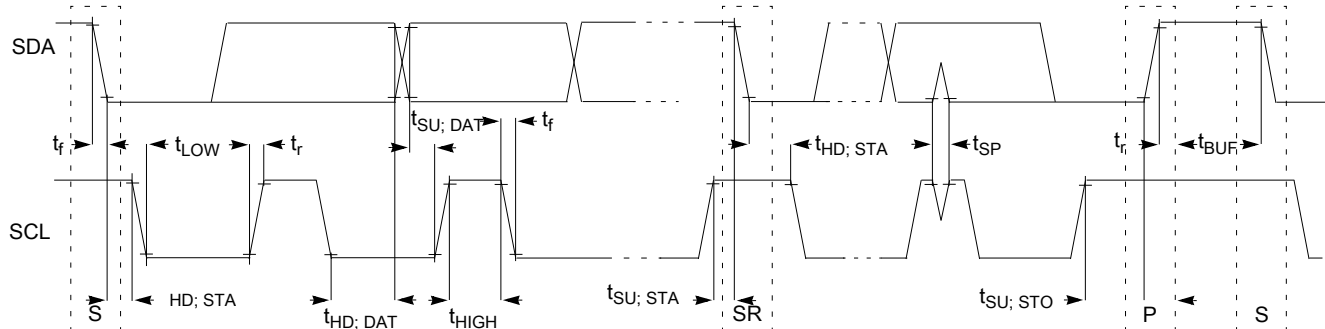

Figure 19. Timing definition for fast and standard mode devices on the I²C bus

6.5.8.5 LPUART

See [General switching specifications](#).

6.5.9 Human-machine interfaces (HMI)

6.5.9.1 GPIO

The maximum input voltage on PTC0/1/2/3 is $V_{DD} + 0.3V$. For rest of the GPIO specification, see [General switching specifications](#).

6.6 DC-DC Converter Operating Requirements

Table 41. DC-DC Converter operating conditions

Characteristic	Symbol	Min	Typ	Max	Unit
Bypass Mode Supply Voltage (RF and Analog)	$V_{DD_{RF1}}$, $V_{DD_{RF2}}$, $V_{DD_{RF3}}$, $V_{DD_{1P5}}$	1.425	—	3.6	Vdc
Bypass Mode Supply Voltage (Digital)	V_{DD_X} , V_{DCDC_IN} , V_{DD_A}	1.71	—	3.6	Vdc
Buck Mode Supply Voltage ^{1, 2}	V_{DCDC_IN}	2.1	—	3.6	Vdc
DC-DC Inductor					
Value		—	10	—	μH

Table continues on the next page...

Table 41. DC-DC Converter operating conditions (continued)

Characteristic	Symbol	Min	Typ	Max	Unit
ESR		—	<0.2	<0.5	Ohms
DC-DC internal oscillator	DCDC _{Int_Osc}	—	26	—	MHz

- In Buck mode, DC-DC converter needs 2.1 V minimum to start, the supply can drop to 1.8 V after DC-DC converter settles.
- In Buck mode, DC-DC converter generates 1.8 V at VDD_1P8OUT and 1.5 V at VDD_1P5OUT_PMCIN pins. VDD_1P8OUT should supply to VDD₁, VDD₂ and VDD_A. VDD_1P5OUT_PMCIN should supply to VDD_RF₁ and VDD_RF₂. VDD_RF₃ can be either supplied by 1.5 V or 1.8 V.

Table 42. DC-DC Converter Specifications

Characteristics	Conditions	Symbol	Min	Typ	Max	Unit
DC-DC Converter Output Power (total power output of 1p8V and 1p5V)	V _{DCDC_IN} above 2.7 V	Pdcdc_out1	—	—	195 ¹	mW
	V _{DCDC_IN} below 2.7 V	Pdcdc_out2	—	—	140 ¹	mW
Switching Frequency ²		DCDC_FREQ	—	DC-DC reference frequency divided by 16 ³	—	MHz
Half FET Threshold		I_half_FET	—	5	—	mA
Double FET Threshold		I_double_FET	—	40	—	mA
Buck Mode						
DC-DC Conversion Efficiency		DCDC_EFF_buck	—	90%	—	—
1.8 V Output Voltage		VDD_1P8_buck	1.71	—	min(VDCDC_IN_buck, 3.5) ^{4, 5}	Vdc
1.8 V Output Current ^{6, 7}	VDD_1P8 = 3.0 V 1.5 V ≤ VDC_1P5 ≤ 1.7 V V _{DCDC_IN} =3.1 V	IDD_1P8_buck1	—	—	39	mA
	VDD_1P8 = 2.65 V 1.5 V ≤ VDC_1P5 ≤ 1.7 V V _{DCDC_IN} =2.7 V	IDD_1P8_buck2	—	—	45	mA
	VDD_1P8 = 1.8 V 1.5 V ≤ VDC_1P5 ≤ 1.7 V V _{DCDC_IN} =2.1 V	IDD_1P8_buck3	—	—	35	mA
1.5 V Output Voltage	Consumed by Radio for P _{out} ≤+3.5 dBm	VDD_1P5_buck	1.45	1.5 ⁸	1.8	Vdc
1.5 V Output Voltage	Consumed by Radio for P _{out} =+5 dBm	VDD_1P5_buck	1.55	1.625 ⁹	1.8	Vdc

Table continues on the next page...

Table 42. DC-DC Converter Specifications (continued)

Characteristics	Conditions	Symbol	Min	Typ	Max	Unit
1.5 V Output Current ^{6, 10}		IDD_1P5_buck	—	—	45	mA
DC-DC Transition Operating Behavior	LSS→Run	t_DCDCbuck_LSS→RUN	—	50	—	μs
DC-DC Turn on Time		T _{DCDC_ON}	—	2.2 ¹¹	—	ms
DC-DC Settling Time for increasing voltage		T _{DCDC_SETTLE_buck}	—	3.11	—	ms/V
DC-DC Settling Time for decreasing voltage	C = capacitance attached to the DC-DC V1P8 output rail. V1 = the initial output voltage of the DC-DC V2 = the final output voltage of the DC-DC I2 = the load on the DC-DC output expressed in Amperes.	T _{DCDC_SETTLE_buck}	—	$(C \cdot (V1 - V2) / I2)$	—	s
VDD_1P8 ripple	Typical ripple based on NXP recommended hardware configuration and typical loading (MCU only; no extra loads placed on DC-DC outputs)	VDD_1P8 _{ripple}	—	30	—	mV
VDD_1P5 ripple	Typical ripple based on NXP recommended hardware configuration and typical loading (MCU only; no extra loads placed on DC-DC outputs)	VDD_1P5 _{ripple}	—	30	—	mV

1. This is the steady state DC output power. Excessive transient current load from external device causes 1p8V and 1P5 output voltage unregulated temporary.
2. This is the frequency that is observed at LN and LP pins.
3. DC-DC reference frequency derives from the RF oscillator or the DC-DC internal oscillator.
4. The voltage output level can be controlled by programming DCDC_VDD1P8CTRL_TRG field in DCDC_REG3.
5. In Buck mode, the maximum VDD_1P8 output is the minimum of either VDCDC_IN_BUCK minus 50 mV or 3.5 V. For example, if VDCDC_IN = 2.1 V, maximum VDD_1P8 is 2.05 V. If VDCDC_IN = 3.6 V, maximum VDD_1P8 is 3.5 V.
6. The output current specification in buck mode represents the maximum current the DC-DC converter can deliver. The KW36A/35A/34A radio and MCU blocks current consumption is not excluded. The maximum output power of the DC-DC converter is 140 mW when V_{DCDC_IN} is below 2.7 V and 195 mW when V_{DCDC_IN} is above 2.7 V. The available supply current for external device depends on the energy consumed by the internal peripherals in KW36A/35A/34A.
7. When using DC-DC in low-power mode (pulsed mode), current load must be less than 1 mA.
8. User needs to program DCDC_VDD1P5CTRL_TRG_BUCK field in DCDC_REG3 register to ensure that a worst case minimum of 1.45 V is available as VDD_1P5_buck. VDD_1P5 must not be programmed higher than VDD_1P8.

9. User needs to program DCDC_VDD1P5CTRL_TRG_BUCK field in DCDC_REG3 register to ensure that a worst case minimum of 1.55 V is available as VDD_1P5_buck. VDD_1P5 must not be programmed higher than VDD_1P8.
10. 1.5 V is intended to supply power to KW36A/35A/34A. It is not designed to supply power to an external device.
11. Turn on time is measured from the application of power (to DCDC_IN) till the DCDC_REG0[DCDC_STS_DC_OK] bit is set. Code execution may begin before the DCDC_REG0[DCDC_STS_DC_OK] bit is set. The full device specification is not guaranteed until the bit sets.

6.7 Ratings

6.7.1 Thermal handling ratings

Table 43. Thermal handling ratings

Symbol	Description	Min.	Max.	Unit	Notes
T _{STG}	Storage temperature	-55	150	°C	1
T _{SDR}	Solder temperature, lead-free	—	260	°C	2

1. Determined according to JEDEC Standard JESD22-A103, *High Temperature Storage Life*.
2. Determined according to IPC/JEDEC Standard J-STD-020, *Moisture/Reflow Sensitivity Classification for Nonhermetic Solid State Surface Mount Devices*.

6.7.2 Moisture handling ratings

Table 44. Moisture handling ratings

Symbol	Description	Min.	Max.	Unit	Notes
MSL	Moisture sensitivity level	—	3	—	1

1. Determined according to IPC/JEDEC Standard J-STD-020, *Moisture/Reflow Sensitivity Classification for Nonhermetic Solid State Surface Mount Devices*.

6.7.3 ESD handling ratings

Table 45. ESD handling ratings

Symbol	Description	Min.	Max.	Unit	Notes
V _{HBM}	Electrostatic discharge voltage, human body model	-2000	+2000	V	1
V _{CDM}	Electrostatic discharge voltage, charged-device model				2
	All pins except the corner pins	-500	500	V	
	Corner pins only	-750	750	V	
I _{LAT}	Latch-up current at ambient temperature of 105 °C	-100	+100	mA	3

1. Determined according to JEDEC Standard JESD22-A114, *Electrostatic Discharge (ESD) Sensitivity Testing Human Body Model (HBM)*.

Pin Diagrams and Pin Assignments

2. Determined according to JEDEC Standard JESD22-C101, *Field-Induced Charged-Device Model Test Method for Electrostatic-Discharge-Withstand Thresholds of Microelectronic Components*.
3. Determined according to JEDEC Standard JESD78, *IC Latch-Up Test*.

6.7.4 Voltage and current operating ratings

Table 46. Voltage and current operating ratings

Symbol	Description	Min.	Max.	Unit
V_{DD}	Digital supply voltage	-0.3	3.8	V
I_{DD}	Digital supply current	—	120	mA
V_{IO}	IO pin input voltage	-0.3	$V_{DD} + 0.3$	V
I_D	Instantaneous maximum current single pin limit (applies to all port pins)	-25	25	mA
V_{DDA}	Analog supply voltage	$V_{DD} - 0.3$	$V_{DD} + 0.3$	V
V_{IO_DCDC}	IO pins in the DC-DC voltage domain (DCDC_CFG and PSWITCH)	GND	VDCDC	V

7 Pin Diagrams and Pin Assignments

7.1 KW36A Signal Multiplexing and Pin Assignments

The following table shows the signals available on each pin and the locations of these pins on the devices supported by this document. The Port Control and Interrupt Module is used to select the functionality for each GPIO pin. ALT0 is reserved for analog functions on some GPIO pins. ALT1 – ALT9 are assigned to the available digital functions on each GPIO pin. GPIO pins with a default of “disabled” are high impedance after reset – their input and output buffers are disabled.

40 "Wettable" HVQ FN	48 "Wettable" HVQ FN	48 LQFN	Pin Name	Default	ALT0	ALT1	ALT2	ALT3	ALT4	ALT5	ALT6	ALT7	ALT8	ALT9
—	4	4	PTA16	DISABLED		PTA16/ LLWU_P4	SPI1_ SOUT	LPUART1_ RTS_b		TPM0_ CH0				
—	5	5	PTA17	DISABLED		PTA17/ LLWU_P5	SPI1_ SIN	LPUART1_ RX	CAN0_TX	TPM_ CLKIN1				
—	6	6	PTA18	DISABLED		PTA18/ LLWU_P6	SPI1_ SCK	LPUART1_ TX	CAN0_RX	TPM2_ CH0				

Pin Diagrams and Pin Assignments

40 "Wett able" HVQ FN	48 "Wett able" HVQ FN	48 LQF N	Pin Name	Default	ALT0	ALT1	ALT2	ALT3	ALT4	ALT5	ALT6	ALT7	ALT8	ALT9
—	7	7	PTA19	ADC0_SE5	ADC0_SE5	PTA19/ LLWU_P7	SPI1_ PCS0	LPUART1_ CTS_b		TPM2_ CH1				
—	24	24	ADC0_DPO	ADC0_ DPO/ CMP0_IN0	ADC0_ DPO/ CMP0_IN0									
—	25	25	ADC0_DM0	ADC0_ DM0/ CMP0_IN1	ADC0_ DM0/ CMP0_IN1									
—	41	41	PTC5	DISABLED		PTC5/ LLWU_ P13/ RF_NOT_ ALLOWED		LPTMR0_ ALT2	LPUART0_ RTS_b	TPM1_ CH1		BSM_CLK		
—	42	42	PTC6	DISABLED		PTC6/ LLWU_ P14/ RF_ RFOSC_ EN		I2C1_SCL	LPUART0_ RX	TPM2_ CH0		BSM_ FRAME		
—	43	43	PTC7	DISABLED		PTC7/ LLWU_P15	SPI0_ PCS2	I2C1_SDA	LPUART0_ TX	TPM2_ CH1		BSM_ DATA		
1	48	48	PTC19	DISABLED		PTC19/ LLWU_P3/ RF_ EARLY_ WARNING	SPI0_ PCS0	I2C0_SCL	LPUART0_ CTS_b	BSM_CLK			LPUART1_ CTS_b	
2	1	1	PTA0	SWD_DIO		PTA0	SPI0_ PCS1			TPM1_ CH0		SWD_DIO		
3	2	2	PTA1	SWD_CLK		PTA1	SPI1_ PCS0			TPM1_ CH1		SWD_CLK		
4	3	3	PTA2	RESET_b		PTA2				TPM0_ CH3		RESET_b		
5	8	8	PSWITCH	PSWITCH	PSWITCH									
6	9	9	DCDC_CFG	DCDC_CFG	DCDC_CFG									
7	9	10	VDCDC_IN	VDCDC_IN	VDCDC_IN									
8	10	11	DCDC_LP	DCDC_LP	DCDC_LP									
9	11	13	DCDC_GND	DCDC_GND	DCDC_GND									
10	12	12	DCDC_LN	DCDC_LN	DCDC_LN									
11	13	14	VDD_1P8OUT	VDD_1P8OUT	VDD_1P8OUT									
12	14	—	DCDC_LN	DCDC_LN	DCDC_LN									

Pin Diagrams and Pin Assignments

40 "Wett able" HVQ FN	48 "Wett able" HVQ FN	48 LQF N	Pin Name	Default	ALT0	ALT1	ALT2	ALT3	ALT4	ALT5	ALT6	ALT7	ALT8	ALT9
13	15	15	VDD_1P5OUT_PMCIN	VDD_1P5OUT_PMCIN	VDD_1P5OUT_PMCIN									
14	16	16	PTB0	DISABLED		PTB0/ LLWU_P8/ RF_ RFOSC_ EN		I2C0_SCL	CMP0_ OUT	TPM0_ CH1		CLKOUT	CAN0_TX	
15	17	17	PTB1	ADC0_ SE1/ CMP0_IN5	ADC0_ SE1/ CMP0_IN5	PTB1/ RF_ PRIORITY	DTM_RX	I2C0_SDA	LPTMR0_ ALT1	TPM0_ CH2		CMT_IRO	CAN0_RX	
16	18	18	PTB2	ADC0_ SE3/ CMP0_IN3	ADC0_ SE3/ CMP0_IN3	PTB2/ RF_NOT_ ALLOWED		DTM_TX		TPM1_ CH0				
17	19	19	PTB3	ADC0_ SE2/ CMP0_IN4	ADC0_ SE2/ CMP0_IN4	PTB3/ ERCLK32K	LPUART1_ RTS_b		CLKOUT	TPM1_ CH1		RTC_ CLKOUT		
18	20	20	VDD_0	VDD_0	VDD_0									
19	21	21	PTB16	EXTAL32K	EXTAL32K	PTB16	LPUART1_ RX	I2C1_SCL		TPM2_ CH0				
20	22	22	PTB17	XTAL32K	XTAL32K	PTB17	LPUART1_ TX	I2C1_SDA		TPM2_ CH1		BSM_CLK		
21	23	23	PTB18	NMI_b	ADC0_ SE4/ CMP0_IN2	PTB18	LPUART1_ CTS_b	I2C1_SCL	TPM_ CLKIN0	TPM0_ CH0		NMI_b		
22	26	26	VREFL/ VSSA	VREFL/ VSSA	VREFL/ VSSA									
23	27	27	VREFH/ VREF_ OUT	VREFH/ VREF_ OUT	VREFH/ VREF_ OUT									
24	28	28	VDDA	VDDA	VDDA									
25	29	29	XTAL_OUT	XTAL_OUT	XTAL_OUT									
26	30	30	EXTAL	EXTAL	EXTAL									
27	31	31	XTAL	XTAL	XTAL									
28	32	32	VDD_RF3	VDD_RF3	VDD_RF3									
29	33	33	ANT	ANT	ANT									
30	34	34	GANT	GANT	GANT									
31	35	35	VDD_RF2	VDD_RF2	VDD_RF2									
32	36	36	VDD_RF1	VDD_RF1	VDD_RF1									
33	37	37	PTC1	DISABLED		PTC1/ RF_ EARLY_ WARNING		I2C0_SDA	LPUART0_ RTS_b	TPM0_ CH2			SPI1_SCK	BSM_CLK

40 "Wett able" HVQ FN	48 "Wett able" HVQ FN	48 LQF N	Pin Name	Default	ALT0	ALT1	ALT2	ALT3	ALT4	ALT5	ALT6	ALT7	ALT8	ALT9
34	38	38	PTC2	DISABLED		PTC2/ LLWU_P10	TX_ SWITCH	I2C1_SCL	LPUART0_ RX	CMT_IRO		DTM_RX	SPI1_ SOUT	BSM_ FRAME
35	39	39	PTC3	DISABLED		PTC3/ LLWU_P11	RX_ SWITCH	I2C1_SDA	LPUART0_ TX	TPM0_ CH1		DTM_TX	SPI1_SIN	CAN0_TX
36	40	40	PTC4	DISABLED		PTC4/ LLWU_ P12/ BLE_RF_ ACTIVE		EXTRG_IN	LPUART0_ CTS_b	TPM1_ CH0		BSM_ DATA	SPI1_ PCS0	CAN0_RX
37	44	44	VDD_1	VDD_1	VDD_1									
38	45	45	PTC16	DISABLED		PTC16/ LLWU_P0/ RF_ STATUS	SPI0_SCK	I2C0_SDA	LPUART0_ RTS_b	TPM0_ CH3			LPUART1_ RTS_b	
39	46	46	PTC17	DISABLED		PTC17/ LLWU_P1/ RF_EXT_ OSC_EN	SPI0_ SOUT	I2C1_SCL	LPUART0_ RX	BSM_ FRAME		DTM_RX	LPUART1_ RX	
40	47	47	PTC18	DISABLED		PTC18/ LLWU_P2	SPI0_SIN	I2C1_SDA	LPUART0_ TX	BSM_ DATA		DTM_TX	LPUART1_ TX	
41	49	49-64	Ground	NA										

7.2 KW36A Pinouts

KW36A device pinouts are shown in the figures below.

Pin Diagrams and Pin Assignments



Figure 20. 40-pin "Wettable" HVQFN pinout diagram



Figure 21. 48-pin LQFN pinout diagram



Figure 22. 48-pin "Wettable" HVQFN pinout diagram

7.3 KW35A Signal Multiplexing and Pin Assignments

The following table shows the signals available on each pin and the locations of these pins on the devices supported by this document. The Port Control and Interrupt Module is used to select the functionality for each GPIO pin. ALT0 is reserved for analog functions on some GPIO pins. ALT1 – ALT9 are assigned to the available digital functions on each GPIO pin. GPIO pins with a default of “disabled” are high impedance after reset – their input and output buffers are disabled.

Pin Diagrams and Pin Assignments

40 "Wett able" HVQ FN	48 "Wett able" HVQ FN	Pin Name	Default	ALT0	ALT1	ALT2	ALT3	ALT4	ALT5	ALT6	ALT7	ALT8	ALT9
—	4	PTA16	DISABLED		PTA16/ LLWU_P4	SPI1_ SOUT			TPM0_CH0				
—	5	PTA17	DISABLED		PTA17/ LLWU_P5	SPI1_SIN			TPM_ CLKIN1				
—	6	PTA18	DISABLED		PTA18/ LLWU_P6	SPI1_SCK			TPM2_CH0				
—	7	PTA19	ADC0_SE5	ADC0_SE5	PTA19/ LLWU_P7	SPI1_PCS0			TPM2_CH1				
—	24	ADC0_DP0	ADC0_ DP0/ CMP0_IN0	ADC0_ DP0/ CMP0_IN0									
—	25	ADC0_DM0	ADC0_ DM0/ CMP0_IN1	ADC0_ DM0/ CMP0_IN1									
—	41	PTC5	DISABLED		PTC5/ LLWU_P13/ RF_NOT_ ALLOWED		LPTMR0_ ALT2	LPUART0_ RTS_b	TPM1_CH1		BSM_CLK		
—	42	PTC6	DISABLED		PTC6/ LLWU_P14/ RF_ RFOSC_ EN		I2C1_SCL	LPUART0_ RX	TPM2_CH0		BSM_ FRAME		
—	43	PTC7	DISABLED		PTC7/ LLWU_P15	SPI0_PCS2	I2C1_SDA	LPUART0_ TX	TPM2_CH1		BSM_DATA		
1	48	PTC19	DISABLED		PTC19/ LLWU_P3/ RF_ EARLY_ WARNING	SPI0_PCS0	I2C0_SCL	LPUART0_ CTS_b	BSM_CLK				
2	1	PTA0	SWD_DIO		PTA0	SPI0_PCS1			TPM1_CH0		SWD_DIO		
3	2	PTA1	SWD_CLK		PTA1	SPI1_PCS0			TPM1_CH1		SWD_CLK		
4	3	PTA2	RESET_b		PTA2				TPM0_CH3		RESET_b		
5	8	PSWITCH	PSWITCH	PSWITCH									
6	9	DCDC_ CFG	DCDC_ CFG	DCDC_ CFG									
7	9	VDCDC_IN	VDCDC_IN	VDCDC_IN									
8	10	DCDC_LP	DCDC_LP	DCDC_LP									
9	11	DCDC_ GND	DCDC_ GND	DCDC_ GND									
10	12	DCDC_LN	DCDC_LN	DCDC_LN									
11	13	VDD_ 1P8OUT	VDD_ 1P8OUT	VDD_ 1P8OUT									
12	14	DCDC_LN	DCDC_LN	DCDC_LN									

Pin Diagrams and Pin Assignments

40 "Wett able" HVQ FN	48 "Wett able" HVQ FN	Pin Name	Default	ALT0	ALT1	ALT2	ALT3	ALT4	ALT5	ALT6	ALT7	ALT8	ALT9
13	15	VDD_1P5OUT_PMCIN	VDD_1P5OUT_PMCIN	VDD_1P5OUT_PMCIN									
14	16	PTB0	DISABLED		PTB0/LLWU_P8/RF_RFOSC_EN		I2C0_SCL	CMP0_OUT	TPM0_CH1		CLKOUT		
15	17	PTB1	ADC0_SE1/CMP0_IN5	ADC0_SE1/CMP0_IN5	PTB1/RF_PRIORITY	DTM_RX	I2C0_SDA	LPTMR0_ALT1	TPM0_CH2		CMT_IRO		
16	18	PTB2	ADC0_SE3/CMP0_IN3	ADC0_SE3/CMP0_IN3	PTB2/RF_NOT_ALLOWED		DTM_TX		TPM1_CH0				
17	19	PTB3	ADC0_SE2/CMP0_IN4	ADC0_SE2/CMP0_IN4	PTB3/ERCLK32K			CLKOUT	TPM1_CH1		RTC_CLKOUT		
18	20	VDD_0	VDD_0	VDD_0									
19	21	PTB16	EXTAL32K	EXTAL32K	PTB16		I2C1_SCL		TPM2_CH0				
20	22	PTB17	XTAL32K	XTAL32K	PTB17		I2C1_SDA		TPM2_CH1		BSM_CLK		
21	23	PTB18	NMI_b	ADC0_SE4/CMP0_IN2	PTB18		I2C1_SCL	TPM_CLKIN0	TPM0_CH0		NMI_b		
22	26	VREFL/VSSA	VREFL/VSSA	VREFL/VSSA									
23	27	VREFH/VREF_OUT	VREFH/VREF_OUT	VREFH/VREF_OUT									
24	28	VDDA	VDDA	VDDA									
25	29	XTAL_OUT	XTAL_OUT	XTAL_OUT									
26	30	EXTAL	EXTAL	EXTAL									
27	31	XTAL	XTAL	XTAL									
28	32	VDD_RF3	VDD_RF3	VDD_RF3									
29	33	ANT	ANT	ANT									
30	34	GANT	GANT	GANT									
31	35	VDD_RF2	VDD_RF2	VDD_RF2									
32	36	VDD_RF1	VDD_RF1	VDD_RF1									
33	37	PTC1	DISABLED		PTC1/RF_EARLY_WARNING		I2C0_SDA	LPUART0_RTS_b	TPM0_CH2			SPI1_SCK	BSM_CLK
34	38	PTC2	DISABLED		PTC2/LLWU_P10	TX_SWITCH	I2C1_SCL	LPUART0_RX	CMT_IRO		DTM_RX	SPI1_SOUT	BSM_FRAME
35	39	PTC3	DISABLED		PTC3/LLWU_P11	RX_SWITCH	I2C1_SDA	LPUART0_TX	TPM0_CH1		DTM_TX	SPI1_SIN	

40 "Wettable" HVQFN	48 "Wettable" HVQFN	Pin Name	Default	ALT0	ALT1	ALT2	ALT3	ALT4	ALT5	ALT6	ALT7	ALT8	ALT9
36	40	PTC4	DISABLED		PTC4/ LLWU_P12/ BLE_RF_ ACTIVE		EXTRG_IN	LPUART0_ CTS_b	TPM1_CH0		BSM_DATA	SPI1_PCS0	
37	44	VDD_1	VDD_1	VDD_1									
38	45	PTC16	DISABLED		PTC16/ LLWU_P0/ RF_ STATUS	SPI0_SCK	I2C0_SDA	LPUART0_ RTS_b	TPM0_CH3				
39	46	PTC17	DISABLED		PTC17/ LLWU_P1/ RF_EXT_ OSC_EN	SPI0_ SOUT	I2C1_SCL	LPUART0_ RX	BSM_ FRAME		DTM_RX		
40	47	PTC18	DISABLED		PTC18/ LLWU_P2	SPI0_SIN	I2C1_SDA	LPUART0_ TX	BSM_DATA		DTM_TX		
41	49	Ground	NA										

7.4 KW35A Pinouts

KW35A device pinouts are shown in the figures below.

Pin Diagrams and Pin Assignments

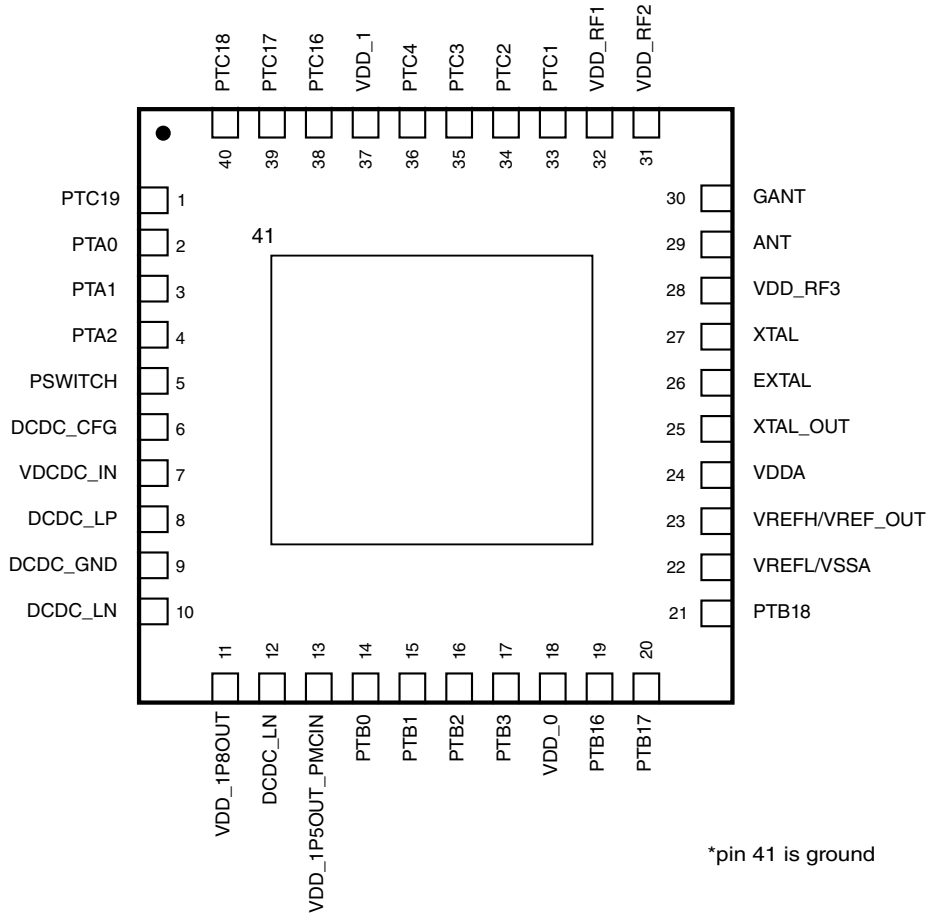

Figure 23. 40-pin "Wettable" HVQFN pinout diagram



Figure 24. 48-pin "Wettable" HVQFN pinout diagram

7.5 KW34A Signal Multiplexing and Pin Assignments

The following table shows the signals available on each pin and the locations of these pins on the devices supported by this document. The Port Control and Interrupt Module is used to select the functionality for each GPIO pin. ALT0 is reserved for analog functions on some GPIO pins. ALT1 – ALT9 are assigned to the available digital functions on each GPIO pin. GPIO pins with a default of “disabled” are high impedance after reset – their input and output buffers are disabled.

Pin Diagrams and Pin Assignments

48 "Wett able" HVQ FN	Pin Name	Default	ALT0	ALT1	ALT2	ALT3	ALT4	ALT5	ALT6	ALT7	ALT8	ALT9
1	PTA0	SWD_DIO		PTA0	SPI0_PCS1			TPM1_CH0		SWD_DIO		
2	PTA1	SWD_CLK		PTA1	SPI1_PCS0			TPM1_CH1		SWD_CLK		
3	PTA2	RESET_b		PTA2				TPM0_CH3		RESET_b		
4	PTA16	DISABLED		PTA16/ LLWU_P4	SPI1_SOUT			TPM0_CH0				
5	PTA17	DISABLED		PTA17/ LLWU_P5	SPI1_SIN			TPM_ CLKIN1				
6	PTA18	DISABLED		PTA18/ LLWU_P6	SPI1_SCK			TPM2_CH0				
7	PTA19	ADC0_SE5	ADC0_SE5	PTA19/ LLWU_P7	SPI1_PCS0			TPM2_CH1				
8	PSWITCH	PSWITCH	PSWITCH									
9	DCDC_CFG/ VDCDC_IN	DCDC_CFG/ VDCDC_IN	DCDC_CFG/ VDCDC_IN									
10	DCDC_LP	DCDC_LP	DCDC_LP									
11	DCDC_GND	DCDC_GND	DCDC_GND									
12	DCDC_LN	DCDC_LN	DCDC_LN									
13	VDD_1P8OUT	VDD_1P8OUT	VDD_1P8OUT									
14	DCDC_LN	DCDC_LN	DCDC_LN									
15	VDD_1P5OUT_ PM CIN	VDD_1P5OUT_ PM CIN	VDD_1P5OUT_ PM CIN									
16	PTB0	DISABLED		PTB0/ LLWU_P8/ RF_ RFOSC_EN		I2C0_SCL	CMP0_OUT	TPM0_CH1		CLKOUT		
17	PTB1	ADC0_SE1/ CMP0_IN5	ADC0_SE1/ CMP0_IN5	PTB1/ RF_ PRIORITY	DTM_RX	I2C0_SDA	LPTMR0_ ALT1	TPM0_CH2		CMT_IRO		
18	PTB2	ADC0_SE3/ CMP0_IN3	ADC0_SE3/ CMP0_IN3	PTB2/ RF_NOT_ ALLOWED		DTM_TX		TPM1_CH0				
19	PTB3	ADC0_SE2/ CMP0_IN4	ADC0_SE2/ CMP0_IN4	PTB3/ ERCLK32K			CLKOUT	TPM1_CH1		RTC_ CLKOUT		
20	VDD_0	VDD_0	VDD_0									
21	PTB16	EXTAL32K	EXTAL32K	PTB16		I2C1_SCL		TPM2_CH0				
22	PTB17	XTAL32K	XTAL32K	PTB17		I2C1_SDA		TPM2_CH1		BSM_CLK		
23	PTB18	NMI_b	ADC0_SE4/ CMP0_IN2	PTB18		I2C1_SCL	TPM_ CLKIN0	TPM0_CH0		NMI_b		
24	ADC0_DP0	ADC0_DP0/ CMP0_IN0	ADC0_DP0/ CMP0_IN0									

Pin Diagrams and Pin Assignments

48 "Wett able" HVQ FN	Pin Name	Default	ALT0	ALT1	ALT2	ALT3	ALT4	ALT5	ALT6	ALT7	ALT8	ALT9
25	ADC0_DM0	ADC0_DM0/ CMP0_IN1	ADC0_DM0/ CMP0_IN1									
26	VREFL/ VSSA	VREFL/ VSSA	VREFL/ VSSA									
27	VREFH/ VREF_OUT	VREFH/ VREF_OUT	VREFH/ VREF_OUT									
28	VDDA	VDDA	VDDA									
29	XTAL_OUT	XTAL_OUT	XTAL_OUT									
30	EXTAL	EXTAL	EXTAL									
31	XTAL	XTAL	XTAL									
32	VDD_RF3	VDD_RF3	VDD_RF3									
33	ANT	ANT	ANT									
34	GANT	GANT	GANT									
35	VDD_RF2	VDD_RF2	VDD_RF2									
36	VDD_RF1	VDD_RF1	VDD_RF1									
37	PTC1	DISABLED		PTC1/ RF_EARLY_ WARNING		I2C0_SDA	LPUART0_ RTS_b	TPM0_CH2			SPI1_SCK	BSM_CLK
38	PTC2	DISABLED		PTC2/ LLWU_P10	TX_SWITCH	I2C1_SCL	LPUART0_ RX	CMT_IRO		DTM_RX	SPI1_SOUT	BSM_ FRAME
39	PTC3	DISABLED		PTC3/ LLWU_P11	RX_ SWITCH	I2C1_SDA	LPUART0_ TX	TPM0_CH1		DTM_TX	SPI1_SIN	
40	PTC4	DISABLED		PTC4/ LLWU_P12/ BLE_RF_ ACTIVE		EXTRG_IN	LPUART0_ CTS_b	TPM1_CH0		BSM_DATA	SPI1_PCS0	
41	PTC5	DISABLED		PTC5/ LLWU_P13/ RF_NOT_ ALLOWED		LPTMR0_ ALT2	LPUART0_ RTS_b	TPM1_CH1		BSM_CLK		
42	PTC6	DISABLED		PTC6/ LLWU_P14/ RF_ RFOSC_EN		I2C1_SCL	LPUART0_ RX	TPM2_CH0		BSM_ FRAME		
43	PTC7	DISABLED		PTC7/ LLWU_P15	SPI0_PCS2	I2C1_SDA	LPUART0_ TX	TPM2_CH1		BSM_DATA		
44	VDD_1	VDD_1	VDD_1									
45	PTC16	DISABLED		PTC16/ LLWU_P0/ RF_STATUS	SPI0_SCK	I2C0_SDA	LPUART0_ RTS_b	TPM0_CH3				
46	PTC17	DISABLED		PTC17/ LLWU_P1/ RF_EXT_ OSC_EN	SPI0_SOUT	I2C1_SCL	LPUART0_ RX	BSM_ FRAME		DTM_RX		

Pin Diagrams and Pin Assignments

48 "Wettable" HVQFN	Pin Name	Default	ALT0	ALT1	ALT2	ALT3	ALT4	ALT5	ALT6	ALT7	ALT8	ALT9
47	PTC18	DISABLED		PTC18/ LLWU_P2	SPI0_SIN	I2C1_SDA	LPUART0_ TX	BSM_DATA		DTM_TX		
48	PTC19	DISABLED		PTC19/ LLWU_P3/ RF_EARLY_ WARNING	SPI0_PCS0	I2C0_SCL	LPUART0_ CTS_b	BSM_CLK				
49	Ground	NA										

7.6 KW34A Pinouts

KW34A device pinouts are shown in the figure below.



Figure 25. 48-pin "Wettable" HVQFN pinout diagram

7.7 Module Signal Description Tables

The following sections correlate the chip-level signal name with the signal name used in the chapter of the module. They also briefly describe the signal function and direction.

7.7.1 Core Modules

This section contains tables describing the core module signal descriptions.

Table 47. SWD Module Signal Descriptions

SoC Signal Name	Module Signal Name	Description	I/O
SWD_DIO	SWD_DIO	Serial Wire Debug Data Input/Output ¹	I/O
SWD_CLK	SWD_CLK	Serial Wire Clock ²	I

- 1. Pulled up internally by default
- 2. Pulled down internally by default

7.7.2 Radio Modules

This section contains tables describing the radio signals.

Table 48. Radio Module Signal Descriptions

Module Signal Name	Pin Direction	Pin Name	Pin Description
ANT	O	ANT	Antenna
BLE_RF_ACTIVE	O	BLE_RF_ACTIVE	An output which is asserted prior to any Radio event and remains asserted for the duration of the event.
BSM_CLK	O	BSM_CLK	Bit Streaming Mode (BSM) clock signal. 1 MHz bit rate clock. BSM_DATA and BSM_FRAME are synchronized to BSM_CLK. External device should capture BSM_FRAME and BSM_DATA on rising edge of BSM_CLK.
BSM_DATA	O	BSM_DATA	Serial Bluetooth LE packet bit stream, LSB-first. Valid on rising edge of BSM_CLK.
BSM_FRAME	O	BSM_FRAME	Framing signal to indicate the start of reception. Active high.
DTM_RX	I	DTM_RX	Direct Test Mode Receive
DTM_TX	O	DTM_TX	Direct Test Mode Transmit
GANT	I	GANT	Antenna ground
RF_STATUS	O	RF_STATUS	An output which indicates when the Radio is in an Rx or Tx event; software can also control this signal directly.
RF_PRIORITY	O	RF_PRIORITY	An output which indicates to the external WiFi device that the Radio event is a high priority and it needs access to the 2.4 GHz antenna.
RF_EARLY_WARNING	O	RF_EARLY_WARNING	Bluetooth LE LL generated signal which can be used to wake an external sensor to make a measurement before a Bluetooth LE event.
RF_NOT_ALLOWED	I	RF_NOT_ALLOWED	External signal which causes the internal Radio to cease radio activity.

Table continues on the next page...

Table 48. Radio Module Signal Descriptions (continued)

Module Signal Name	Pin Direction	Pin Name	Pin Description
RF_TX_CONF	I	RF_TX_CONF	Signal from an external Radio which indicates the availability of the 2.4 GHz antenna to the internal Radio. NOTE: This is a GPIO, not a dedicated PIN.
RX_SWITCH	O	RX_SWITCH	Front End Module receive mode signal.
TX_SWITCH	O	TX_SWITCH	Front End Module transmit mode signal.

Table 49. Radio Module Miscellaneous Pin Descriptions

Pin Name	Pad Direction	Pin Name	Pin Description
RF_INT_OSC_EN	I	RF_RFOSC_EN	External request to turn on the Radio's internal RF oscillator.
RF_EXT_OSC_EN	O	RF_EXT_OSC_EN	Internal request to turn on an External oscillator for use by the internal Radio. The request can also be from the SoC if it is using the RF oscillator as its clock.

7.7.3 System Modules

This section contains tables describing the system signals.

Table 50. System Module Signal Descriptions

SoC Signal Name	Module Signal Name	Description	I/O
NMI_b	—	Non-maskable interrupt	I
RESET_b	—	Reset bidirectional signal	I/O
VDD_[1:0]	VDD	Power supply	I
Ground	VSS	Ground	I
VDD_RF[3:1]	VDD_RF	Radio power supply	I
VDCDC_IN	VDCDC_IN	VDCDC_IN	I
VDD_1P8OUT	VDD_1P8	DC-DC 1.8 V Regulated Output / Input in bypass	I/O
VDD_1P5OUT_PMCIN	VDD_1P5/VDD_PMC	DC-DC 1.5 V Regulated Output / PMC Input in bypass	I/O
PSWITCH	PSWITCH	DC-DC enable switch	I
DCDC_CFG	DCDC_CFG	DC-DC switch mode select	I
DCDC_LP	DCDC_LP	DC-DC inductor input positive	I/O

Table continues on the next page...

Table 50. System Module Signal Descriptions (continued)

SoC Signal Name	Module Signal Name	Description	I/O
DCDC_LN	DCDC_LN	DC-DC inductor input negative	I/O
DCDC_GND	DCDC_GND	DC-DC ground	I

Table 51. LLWU Module Signal Descriptions

SoC Signal Name	Module Signal Name	Description	I/O
LLWU_P[15:0]	LLWU_P[15:0]	Wake-up inputs	I

7.7.4 Clock Modules

This section contains tables for Clock signal descriptions.

Table 52. Clock Module Signal Descriptions

SoC Signal Name	Module Signal Name	Description	I/O
EXTAL	EXTAL	26 MHz/32 MHz External clock/Oscillator input	I
XTAL	XTAL	26 MHz/32 MHz Oscillator input	I
XTAL_OUT	XTAL_OUT	26 MHz/32 MHz Clock output	O
XTAL_OUT_EN	XTAL_OUT_ENABLE	26 MHz/32 MHz Clock output enable for XTAL_OUT	I
EXTAL32K	EXTAL32K	32 kHz External clock/Oscillator input	I
XTAL32K	XTAL32K	32 kHz Oscillator input	I
CLKOUT	CLKOUT	Internal clocks monitor	O

7.7.5 Analog Modules

This section contains tables for Analog signal descriptions.

Table 53. ADC0 Signal Descriptions

SoC Signal Name	Module Signal Name	Description	I/O
ADC0_DM0	DADM0	ADC Channel 0 Differential Input Negative	I

Table continues on the next page...

Table 53. ADC0 Signal Descriptions (continued)

SoC Signal Name	Module Signal Name	Description	I/O
ADC0_DP0	DADP0	ADC Channel 0 Differential Input Positive	I
ADC0_SE[5:1]	AD[5:1]	ADC Channel 0 Single-ended Input n	I
VREFH	V _{REFSH}	Voltage Reference Select High	I
VDDA	V _{DDA}	Analog Power Supply	I
VSSA	V _{SSA}	Analog Ground	I

Table 54. CMP0 Signal Descriptions

SoC Signal Name	Module Signal Name	Description	I/O
CMP0_IN[5:0]	IN[5:0]	Analog voltage inputs	I
CMP0_OUT	CMP0	Comparator output	O

Table 55. VREF Signal Descriptions

SoC Signal Name	Module Signal Name	Description	I/O
VREF_OUT	VREF_OUT	Internally generated voltage reference output	O

7.7.6 Timer Modules

This section contains tables describing timer module signals.

Table 56. TPM0 Module Signal Descriptions

SoC Signal Name	Module Signal Name	Description	I/O
TPM_CLKIN[1:0]	TPM_EXTCLK	External clock	I
TPM0_CH[3:0]	TPM_CH[3:0]	TPM channel	I/O

Table 57. TPM1 Module Signal Descriptions

SoC Signal Name	Module Signal Name	Description	I/O
TPM_CLKIN[1:0]	TPM_EXTCLK	External clock	I
TPM1_CH[1:0]	TPM_CH[1:0]	TPM channel	I/O

Table 58. TPM2 Module Signal Descriptions

SoC Signal Name	Module Signal Name	Description	I/O
TPM_CLKIN[1:0]	TPM_EXTCLK	External clock	I
TPM2_CH[1:0]	TPM_CH[1:0]	TPM channel	I/O

Table 59. LPTMR0 Module Signal Descriptions

SoC Signal Name	Module Signal Name	Description	I/O
LPTMR0_ALT[2:1]	LPTMR0_ALT[2:1]	Pulse counter input pin	I

Table 60. RTC Module Signal Descriptions

SoC Signal Name	Module Signal Name	Description	I/O
RTC_CLKOUT	RTC_CLKOUT	1 Hz square-wave output	O

7.7.7 Communication Interfaces

This section contains tables for the signal descriptions for the communication modules.

Table 61. SPI0 Module Signal Descriptions

SoC Signal Name	Module Signal Name	Description	I/O
SPI0_PCS0	PCS0/SS	Chip Select/Slave Select	I/O
SPI0_PCS[2:1]	PCS[2:1]	Chip Select	O
SPI0_SCK	SCK	Serial Clock	I/O
SPI0_SIN	SIN	Data In	I
SPI0_SOUT	SOUT	Data Out	O

Table 62. SPI1 Module Signal Descriptions

SoC Signal Name	Module Signal Name	Description	I/O
SPI1_PCS0	SPI1_PCS0	Chip Select/Slave Select	I/O
SPI1_SCK	SCK	Serial Clock	I/O
SPI1_SIN	SIN	Data In	I
SPI1_SOUT	SOUT	Data Out	O

Table 63. I2C0 Module Signal Descriptions

SoC Signal Name	Module Signal Name	Description	I/O
I2C0_SCL	SCL	I2C serial clock line	I/O
I2C0_SDA	SDA	I2C serial data line	I/O

Table 64. I2C1 Module Signal Descriptions

SoC Signal Name	Module Signal Name	Description	I/O
I2C1_SCL	SCL	I2C serial clock line	I/O
I2C1_SDA	SDA	I2C serial data line	I/O

Table 65. CAN0 Signal Descriptions (KW36 only)

SoC Signal Name	Module Signal Name	Description	I/O
CAN0_RX	CAN RX	CAN Receive Pin	I
CAN0_TX	CAN TX	CAN Transmit Pin	O

Table 66. LPUART0 Module Signal Descriptions

SoC Signal Name	Module Signal Name	Description	I/O
LPUART0_CTS_b	LPUART CTS	Clear To Send	I
LPUART0_RTS_b	LPUART RTS	Request To Send	O
LPUART0_RX	LPUART RxD	Receive Data	I
LPUART0_TX	LPUART TxD	Transmit Data ¹	I/O

1. This pin is normally an output, but is an input (tristated) in single wire mode whenever the transmitter is disabled or transmit direction is configured for receive data

Table 67. LPUART1 Module Signal Descriptions (KW36 only)

SoC Signal Name	Module Signal Name	Description	I/O
LPUART1_CTS_b	LPUART CTS	Clear To Send	I
LPUART1_RTS_b	LPUART RTS	Request To Send	O
LPUART1_RX	LPUART RxD	Receive Data	I
LPUART1_TX	LPUART TxD	Transmit Data ¹	I/O

1. This pin is normally an output, but is an input (tristated) in single wire mode whenever the transmitter is disabled or transmit direction is configured for receive data

7.7.8 Human-Machine Interfaces(HMI)

This section contains tables describing the HMI signals.

Table 68. GPIO Module Signal Descriptions

SoC Signal Name	Module Signal Name	Description	I/O
PTA[19:16][2:0]	PORTA19-16, 2-0	General Purpose Input/ Output	I/O
PTB[18:16][3:0]	PORTB18-16, 3-0	General Purpose Input/ Output	I/O
PTC[19:16][7:1]	PORTC19-16, 7-1	General Purpose Input/ Output	I/O

8 Package Information

8.1 Obtaining package dimensions

Package dimensions are available in package drawings.

To find a package drawing, go to nxp.com and perform a keyword search for the document number of the drawing:

Table 69. Packaging Dimensions

If you want the drawing for this package	Then use this document number
40-pin "Wettable" HVQFN (6x6)	98ASA01025D
48-pin LQFN (7x7)	98ASA00694D
48-pin "Wettable" HVQFN (7x7)	98ASA01307D

9 Part identification

9.1 Description

Part numbers for the chip have fields that identify the specific part. You can use the values of these fields to determine the specific part you have received.

9.2 Format

Part numbers for this device have the following format:

Q KW## A FFF R T PP CC N

9.3 Fields

This table lists the possible values for each field in the part number (not all combinations are valid):

Table 70. Part number fields descriptions

Field	Description	Values
Q	Qualification status	<ul style="list-style-type: none"> M = Fully qualified, general market flow P = Prequalification
KW##	Kinetis Wireless family	<ul style="list-style-type: none"> KW34 KW35 KW36
A	Key attribute	<ul style="list-style-type: none"> A = Automotive Qualification
FFF	Program flash memory size	<ul style="list-style-type: none"> 512 = 512 KB
T	Temperature range (°C)	<ul style="list-style-type: none"> V = -40 to 105 C = -40 to 85
PP	Package identifier	<ul style="list-style-type: none"> HT = 48 LQFN (7 mm x 7 mm) FP = 40 "Wettable" HVQFN (6 mm x 6 mm) FT = 48 "Wettable" HVQFN (7 mm x 7 mm)
CC	Maximum CPU frequency (MHz)	<ul style="list-style-type: none"> 4 = 48 MHz
N	Packaging type	<ul style="list-style-type: none"> (Blank) = Tray R = Tape and reel

9.4 Example

This is an example part number:

MKW36A512VFT4

10 Revision History

Table 71. Revision History

Rev. No.	Date	Substantial Changes
Rev 8	05/2020	<ul style="list-style-type: none"> • Updated Tx output power to 5 dBm from 3.5 dBm throughout. Also preceded 5 dBm with a plus "+" sign. • Replaced VDD_XTAL with VDD_RF3. • Appended the second row 'Supply current Rx On with DC-DC converter enable' with the following text: VDD_1P5_buck=1.5 V in Receiver Feature Summary. • In Top level Transmitter Specifications - Table 5 : <ul style="list-style-type: none"> • Appended the rows for supply current Tx On with P_{RF} and DC-DC converter enabled for 0 dBm with VDD_1P5_buck=1.5 V. • Added rows related to supply current Tx On with PRF = +3.5 dBm and 5dBm along with associated footnotes. • Updated symbol of Output RF Frequency to f_{RFout} from f_{in}. • Added row for maximum RF Output Power; LDO-HF bumped along with an associated footnote. • Added Figure 5. • Added Table 7. Also modified title of Table 6. • Added VDD_1P5 specification in Voltage and current operating requirements. • Added VPOR_VDD_1P5 specification in LVD and POR operating requirements • Added V_{OH} performance for normal drive pad at 1.71 V ≤ V_{DD} ≤ 2.7 V, I_{OH} = -1 mA in Voltage and current operating behaviors. • Added Table 17. Also updated title of Table 16. • Updated V_{CDM} ratings in ESD handling ratings. • Added VDD_1P5 symbol to "Bypass Mode Supply Voltage (RF and Analog)" in Table 41. • In Table 42 : <ul style="list-style-type: none"> • Updated specifications of DC-DC Converter Output Power. Added conditions, V_{DCDC_IN} above 2.7 V and below 2.7 V. • Updated specifications of 1.8 V Output Current. • Updated minimum value to 1.45 V in "1.5 V Voltage Output" for P_{out}≤+3.5 dBm. Updated the corresponding footnote with the correct value of 1.45 V. • Added a separate row for "1.5 V Voltage Output" for P_{out}=+5 dBm along with a footnote. • Updated maximum value of 1.5 V Output Current to 45.
Rev 7	09/2019	<ul style="list-style-type: none"> • Removed flash access control feature from Security Features. • Added the following footnote to Table 14 : "The device was configured in buck mode auto-start to perform the measurements. The DCDC_IN was powered with 3.0 V. VDD_1P8OUT was configured to output 1.8 V and VDD_1P5OUT_PMCIN was configured to output 1.5 V." • Added the following footnote to VLPS, LLSx and VLLSx modes: "DCDC configured in pulsed mode." in Table 14. • Added thermal attributes for 48-pin "Wettable" HVQFN package, and replaced standard JESD51-2 with JESD51-2A in the footnotes in Thermal attributes. • Removed "Flash timing specifications – program and erase" and "Flash high voltage current behaviors" tables. • Added <i>DCDC internal oscillator</i> row in Table 41. • Updated Table 42 as follows: <ul style="list-style-type: none"> • In <i>Switching Frequency</i> row, updated the Typical value to <i>DCDC reference frequency divided by 16</i> and added the following footnote to it: "DCDC reference frequency is derived from the RF oscillator or the DCDC internal oscillator". • Added <i>VDD_1P8 ripple</i> and <i>VDD_1P5 ripple</i> rows.

Table continues on the next page...

Table 71. Revision History (continued)

Rev. No.	Date	Substantial Changes
		<ul style="list-style-type: none"> Updated introductory text beginning "The Port Control and Interrupt Module is used to select the functionality for...." in KW36A Signal Multiplexing and Pin Assignments. Same update done for KW35A and KW34A as well. Updated "DEFAULT" column to correct "DISABLED" status of PTA19, PTB1/2/3 pin names in KW36/35/34 pinouts.
Rev 7 Draft B	04/2019	<ul style="list-style-type: none"> Added "Top Line Marking" column to the Orderable parts details table. Removed "Galois counter mode (AES-GCM)" and "DES modes" features of LTC from Security Features. Removed "Logic Input Voltage Low/High" rows from Table 2. Removed the following footnote from Table 13 : "Supported through the connectivity software in its pre-defined Deep Sleep Modes." Updated Typical value of I_{DD_RUN} at 70 °C to 5.92 in Table 14. Added "48-pin Wettable HVQFN" column to Thermal attributes. Corrected name of V_{ec_xtal32} to V_{ec_extal32} in 32 kHz Oscillator Frequency Specifications. Updated minimum and maximum values of "1.5V Output Voltage" in Table 42. Also specified the condition as "Consumed by radio". Corrected location of ground pins in 48-pin LQFN pinout diagram - Figure 21. Removed CAN0 and LPUART1 references from KW34A Signal Multiplexing and Pin Assignments.
Rev 7 Draft A	11/2018	<ul style="list-style-type: none"> Added following part numbers: MKW36A512VFT4, MKW35A512VFT4, and MKW34A512VFT4 Added 48 "Wettable" QFN package details including pin diagrams and assignments. Changed 40-pin "Wettable" QFN and 48-pin "Wettable" QFN to 40-pin "Wettable" HVQFN and 48-pin "Wettable" HVQFN throughout. Applied new NXP Brand Guidelines for Bluetooth Low Energy. Removed references of BLE and replaced with Bluetooth LE. Added the following footnote in Table 6 : "TX continuous wave power output at the RF pins with the recommended matching components mounted on PCB." Corrected maximum value of VDD_1P8 output in the footnote 6, in Table 42. DC-DC Converter Specifications, from 3 V to 3.5 V. Removed silicon revision (R) field from Table 68. Part number fields descriptions.
Rev 6	09/2018	<ul style="list-style-type: none"> Changed ARM to Arm and applied registered trademark to Cortex on first instance. Updated Related Resources table for Web release. Updated Introduction section to remove industrial details. Added space between value and unit throughout. Removed SPI Clock Rate row from Radio Operating Conditions. Added figure title to Figure 3 in the topic Transmit and PLL Feature Summary. Updated max values of IDD_STOP, IDD_LLS3/LLS2, IDD_VLLS0 (POR PO =) in Table 13 Updated Table 25 and Table 26. Updated Table 27 - Flash command timing specifications. Updated Table 28 - NVM reliability specifications. Backpage was also updated.
Rev 5	07/2018	<ul style="list-style-type: none"> Updated title of the document to 'MKW36A/35A Data Sheet' from 'MKW35A/36A Data Sheet'. Updated SoC name KW35A with KW36A/35A throughout. Replaced QFN with "Wettable" QFN throughout Added package drawings on front page and updated features under Multi-Standard Radio section as follows: Modulation index: added 1.0 to the list. Updated Typical Rx Current and Typical Tx current values to 6.3 mA and 5.7 mA respectively. Updated Low Power Mode (VLLS0) Current value to 258 nA from 182 nA. Replaced column name "Tier" with "Qualification" in this table.

Table continues on the next page...

Table 71. Revision History (continued)

Rev. No.	Date	Substantial Changes
		<ul style="list-style-type: none"> • Updated Introduction section. • Removed Radio version number "V2.1" from Block Diagram. • Updated Radio features, Microcontroller features, and System features. • Appended "(Zero IF)" to Direct Conversion Receiver in Transceiver Description. • Edited Key Specifications. • Updated Receiver Sensitivity to –99 from –100 dBm in Radio features. Also added support of 1 Mbps PHY to BLE link Layer hardware. • Updated typical and minimum values in Table 3. Also updated footnote 7 to "BLE adjacent and alternate selectivity performance is measured with modulated interference signals." • In Table 4 : <ul style="list-style-type: none"> • updated and added receiver specifications with GFSK modulations, and • updated footnote as follows: "Selectivity measured with an unmodulated blocker except for GFSK BT=0.5, h=0.5 1mbps and GFSK BT=0.5, h=0.32 1mbps. The desired signal is set at –85 dBm." • Updated typical and maximum values in Table 5. Also updated footnote for TXH2 and TXH3 symbols as follows: "Harmonic Levels based on recommended 2 component match. Transmit harmonic levels depend on the quality of matching components. Additional harmonic margin using a 3rd matching component (1x shunt capacitor) is possible." • Updated typical and maximum values in Table 13 and Table 14. • Updated typical values in Table 16. Also added specifications of STOP and RUN modes of radio state Tx (at +3.5 dBm). • Updated 48-pin LQFN and 40-pin QFN values in Thermal attributes table. Removed thermal metrics and kept thermal attributes $R_{\theta JA}$ and Ψ_{JT}. Also updated notes and added information about how to use the thermal characterization parameter, Ψ_{JT}. • Added following text in Reference Oscillator Specification : "The table below shows the recommended crystal specifications. Note that these are recommendations.....". Also updated 32M/26M typical values of Oscillator Startup Time to 500 μs. • Updated typical and maximum values in Table 1 • Updated minimum, typical and maximum value of Temp sensor slope in Table 30 • Updated Table 1. • Added a footnote under Buck Mode Supply Voltage in Table 41. • Corrected spec name of Buck mode in DC-DC configuration to V_{DCDC_IN} from VDD_{DCDC_IN} throughout. • In Table 42, <ul style="list-style-type: none"> • added a footnote for maximum value of DC-DC Converter Output Power, • updated footnote example corresponding to '1.8V Output Voltage', • updated maximum value in '1.8V Output Voltage' from "min(VDCDC_IN_buck, 3)" to "min(VDCDC_IN_buck, 3.5)", • added $VDD_1P8 = 1.8V$ and $VDD_1P5 = 1.5V$ conditions in 1.8V Output Current, and • added the following information to the footnote corresponding to '1.5V Output Voltage': "VDD_1P5 must not be programmed higher than VDD_1P8." • Added V_{IO_DCDC} row in Voltage and current operating ratings. • Removed 48-pin LQFN pinout diagram and signal names from KW35A Signal Multiplexing and Pin Assignments. Also updated signal name at pin 17 and pin 19 of 40 "Wettable" QFN and 48 LQFN in ALT1 functionality to PTB3/ERCLK32K in KW36A Signal Multiplexing and Pin Assignments and KW35A Signal Multiplexing and Pin Assignments.
Rev 4	10/2017	<ul style="list-style-type: none"> • BLE version 4.2 updated to 5.0. • Updated maximum value of voltage range to 3.6 V. • Updated Generic FSK modulation BT and receiver sensitivity from –100 dBm to –99 dBm. • Added support of up to 26 devices by Whitelist and 8 private resolvable addresses in hardware in the section Radio features. • Updated number of GPIO digital pins in the 48-pin package to 25 in Peripheral features.

Table continues on the next page...

Table 71. Revision History (continued)

Rev. No.	Date	Substantial Changes
		<ul style="list-style-type: none"> Updated note text in Radio operating conditions as follows: "The recommended crystal accuracy is ± 40 ppm including initial accuracy, mechanical, temperature and aging factors." Updated maximum values in Power mode transition operating behaviors. Updated Typical values in Table 13 and Table 14. Also added the following note to the tables for Run mode: "Radio is off". Minor updates in introductory text of Reference Oscillator Specification section. Also updated typical value of T_{OSC} to 680 μs in . Added 32 kHz Oscillator Frequency Specifications section. Updated Table 42 section. <ul style="list-style-type: none"> Added the following parameters: Switching Frequency, Half FET Threshold, Double FET Threshold, DC-DC Conversion Efficiency, DCDC Settling Time for increasing voltage and DCDC Settling Time for decreasing voltage. Updated Typ. value of the 'DCDC Turn on Time' parameter and added a footnote.
Rev 3	06/2017	Updated Typical values in Table 13 and Table 14 .
Rev 2	03/2017	<ul style="list-style-type: none"> Modified structure of the document to include orderable part numbers and Related Resources table after the features list. Specified all supported part numbers on the front page. Specified the baudrate supported by FlexCAN in the features list. Updated value of minimum input voltage to 1.71 V and output voltage to 1.8 V from 2.7 V. Also updated minimum voltage value in DCDC buck mode to 2.1 V from 2.7 V. Changed RSSI Range maximum value to 5 dBm in Table 3 and added the following footnote: "With RSSI_CTRL_0.RSSI_ADJ field calibrated to account for antenna to RF input losses." Added Table 6 to show mapping relationship between TX_POWER and DBM. Also added the corresponding graph. Added DCDC Inductor specifications in Table 41. Updated Table 42 : <ul style="list-style-type: none"> Removed repetitive fields from the table. Specified Typ. value of "DCDC Transition Operating Behavior" as 50 μs. Updated footnote 3 as follows: "In Buck mode, the maximum VDD_1P8 output is the minimum of either VDCDC_IN_BUCK minus 50 mV or 3 V. For example, if VDCDC_IN = 1.85 V, maximum VDD_1P8 is 1.8 V. If VDCDC_IN = 4.2 V, maximum VDD_1P8 is 3 V." Replaced Laminate QFN with LQFN throughout. Added radio signals in Table 48. Added document numbers of the supported package drawings in Table 69. Added Part identification section.
Rev 1	01/2017	<ul style="list-style-type: none"> Updated maximum supply voltage from 4.2 to 4.25 V. Corrected MBAN Channel numbering in Channel Plan for Bluetooth Low Energy. Corrected "Radio" description for VLLS1 and VLLS0 power modes in Table 8. Updated Section 9 Pin Diagrams and Pin Assignments. <ul style="list-style-type: none"> Corrected pin name from VDD_1P45OUT_PMCIN to VDD_1P5OUT_PMCIN Added ground pads in the pin diagrams Put Typ. values as TBDs in Table 14, Power consumption operating behaviors - Buck Mode. Added the following note in Diagram: Typical IDD_RUN operating behavior : "The results in the following graphs are obtained using the device in Bypass mode." Put Typ. values as TBDs in Table 16, SoC Power Consumption. Added T_{OSC} row in , Reference Crystal Specification. Added DCDC Transition Operating Behavior and DCDC Turn on Time in Table 42, DC-DC Converter Specifications. Added the following note in Table 48 for the RF_TX_CONF pin: "This is a GPIO, not a dedicated PIN."

Table continues on the next page...

Revision History

Table 71. Revision History (continued)

Rev. No.	Date	Substantial Changes
Rev 0	11/2016	Initial Internal Release

How to Reach Us:**Home Page:**nxp.com**Web Support:**nxp.com/support

Information in this document is provided solely to enable system and software implementers to use NXP products. There are no express or implied copyright licenses granted hereunder to design or fabricate any integrated circuits based on the information in this document. NXP reserves the right to make changes without further notice to any products herein.

NXP makes no warranty, representation, or guarantee regarding the suitability of its products for any particular purpose, nor does NXP assume any liability arising out of the application or use of any product or circuit, and specifically disclaims any and all liability, including without limitation consequential or incidental damages. "Typical" parameters that may be provided in NXP data sheets and/or specifications can and do vary in different applications, and actual performance may vary over time. All operating parameters, including "typicals," must be validated for each customer application by customer's technical experts. NXP does not convey any license under its patent rights nor the rights of others. NXP sells products pursuant to standard terms and conditions of sale, which can be found at the following address: nxp.com/SalesTermsandConditions.

While NXP has implemented advanced security features, all products may be subject to unidentified vulnerabilities. Customers are responsible for the design and operation of their applications and products to reduce the effect of these vulnerabilities on customer's applications and products, and NXP accepts no liability for any vulnerability that is discovered. Customers should implement appropriate design and operating safeguards to minimize the risks associated with their applications and products.

NXP, the NXP logo, NXP SECURE CONNECTIONS FOR A SMARTER WORLD, COOLFLUX, EMBRACE, GREENCHIP, HITAG, ICODE, JCOP, LIFE VIBES, MIFARE, MIFARE CLASSIC, MIFARE DESFire, MIFARE PLUS, MIFARE FLEX, MANTIS, MIFARE ULTRALIGHT, MIFARE4MOBILE, MIGLO, NTAG, ROADLINK, SMARTLX, SMARTMX, STARPLUG, TOPFET, TRENCHMOS, UCODE, Freescale, the Freescale logo, AltiVec, CodeWarrior, ColdFire, ColdFire+, the Energy Efficient Solutions logo, Kinetis, Layerscape, MagniV, mobileGT, PEG, PowerQUICC, Processor Expert, QorIQ, QorIQ Qonverge, SafeAssure, the SafeAssure logo, StarCore, Symphony, VortiQa, Vybrid, Airfast, BeeKit, BeeStack, CoreNet, Flexis, MXC, Platform in a Package, QUICC Engine, Tower, TurboLink, EdgeScale, EdgeLock, eIQ, and Immersive3D are trademarks of NXP B.V. All other product or service names are the property of their respective owners. AMBA, Arm, Arm7, Arm7TDMI, Arm9, Arm11, Artisan, big.LITTLE, Cordio, CoreLink, CoreSight, Cortex, DesignStart, DynamIQ, Jazelle, Keil, Mali, Mbed, Mbed Enabled, NEON, POP, RealView, SecurCore, Socrates, Thumb, TrustZone, ULINK, ULINK2, ULINK-ME, ULINK-PLUS, ULINKpro, μ Vision, Versatile are trademarks or registered trademarks of Arm Limited (or its subsidiaries) in the US and/or elsewhere. The related technology may be protected by any or all of patents, copyrights, designs and trade secrets. All rights reserved. Oracle and Java are registered trademarks of Oracle and/or its affiliates. The Power Architecture and Power.org word marks and the Power and Power.org logos and related marks are trademarks and service marks licensed by Power.org.

© 2016-2020 NXP B.V.

Document Number MKW36A512
Revision 8, 05/2020



Компания «Life Electronics» занимается поставками электронных компонентов импортного и отечественного производства от производителей и со складов крупных дистрибьюторов Европы, Америки и Азии.

С конца 2013 года компания активно расширяет линейку поставок компонентов по направлению коаксиальный кабель, кварцевые генераторы и конденсаторы (керамические, пленочные, электролитические), за счёт заключения дистрибьюторских договоров

Мы предлагаем:

- Конкурентоспособные цены и скидки постоянным клиентам.
- Специальные условия для постоянных клиентов.
- Подбор аналогов.
- Поставку компонентов в любых объемах, удовлетворяющих вашим потребностям.
- Приемлемые сроки поставки, возможна ускоренная поставка.
- Доставку товара в любую точку России и стран СНГ.
- Комплексную поставку.
- Работу по проектам и поставку образцов.
- Формирование склада под заказчика.
- Сертификаты соответствия на поставляемую продукцию (по желанию клиента).
- Тестирование поставляемой продукции.
- Поставку компонентов, требующих военную и космическую приемку.
- Входной контроль качества.
- Наличие сертификата ISO.

В составе нашей компании организован Конструкторский отдел, призванный помогать разработчикам, и инженерам.

Конструкторский отдел помогает осуществить:

- Регистрацию проекта у производителя компонентов.
- Техническую поддержку проекта.
- Защиту от снятия компонента с производства.
- Оценку стоимости проекта по компонентам.
- Изготовление тестовой платы монтаж и пусконаладочные работы.



Тел: +7 (812) 336 43 04 (многоканальный)
Email: org@lifeelectronics.ru