

**MULTIPLE RS-232 DRIVERS AND RECEIVERS****AZ75232****General Description**

The AZ75232 combines three drivers and five receivers, which conform to the EIA/TIA-232-F and ITU v.28 standards. Each receiver converts EIA/TIA-232-F inputs to 5-V TTL/CMOS levels and each driver converts TTL/CMOS input levels into EIA/TIA-232-F levels.

The flow-through pinout facilitates simple non-cross-over board layout. The AZ75232 provides a one-chip solution for the common 9-pin serial RS-232 interface between data terminal and data communications equipment.

The AZ75232 is available in SOIC-20, SSOP-20 and TSSOP-20 packages.

**Features**

- Single Chip with Easy Interface between UART and Serial-Port Connector
- Meet the Requirement of EIA/TIA-232-F and ITU v.28 Standards
- Designed to Support Data Rates up to 120kbit/s
- 3 Drivers and 5 Receivers
- Flow-through Pinout

**Applications**

- Mother Board
- Peripheral Equipment



Figure 1. Package Types of AZ75232

**MULTIPLE RS-232 DRIVERS AND RECEIVERS**

**AZ75232**

**Pin Configuration**

M/GS/G Package  
(SOIC-20/SSOP-20/TSSOP-20)

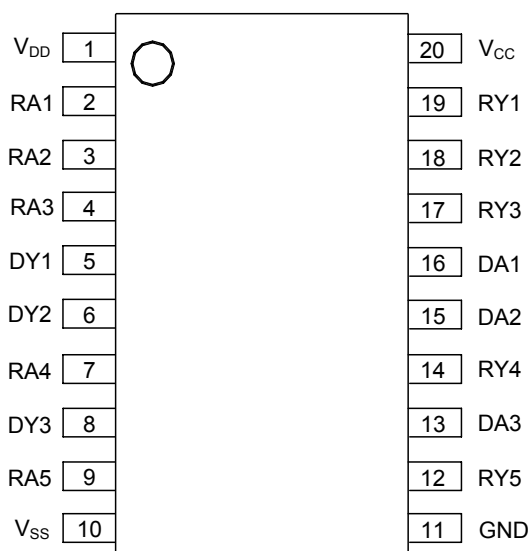

Figure 2. Pin Configuration of AZ75232 (Top View)

**Pin Description**

Pin Number	Pin Name	Function	Pin Number	Pin Name	Function
1	V <sub>DD</sub>	Positive Supply Voltage for Driver	11	GND	Ground
2	RA1	Receiver Input	12	RY5	Receiver Output
3	RA2	Receiver Input	13	DA3	Driver Input
4	RA3	Receiver Input	14	RY4	Receiver Output
5	DY1	Driver Output	15	DA2	Driver Input
6	DY2	Driver Output	16	DA1	Driver Input
7	RA4	Receiver Input	17	RY3	Receiver Output
8	DY3	Driver Output	18	RY2	Receiver Output
9	RA5	Receiver Input	19	RY1	Receiver Output
10	V <sub>SS</sub>	Negative Supply Voltage for Driver	20	V <sub>CC</sub>	Supply Voltage for Receiver



**MULTIPLE RS-232 DRIVERS AND RECEIVERS**

**AZ75232**

**Functional Block Diagram**

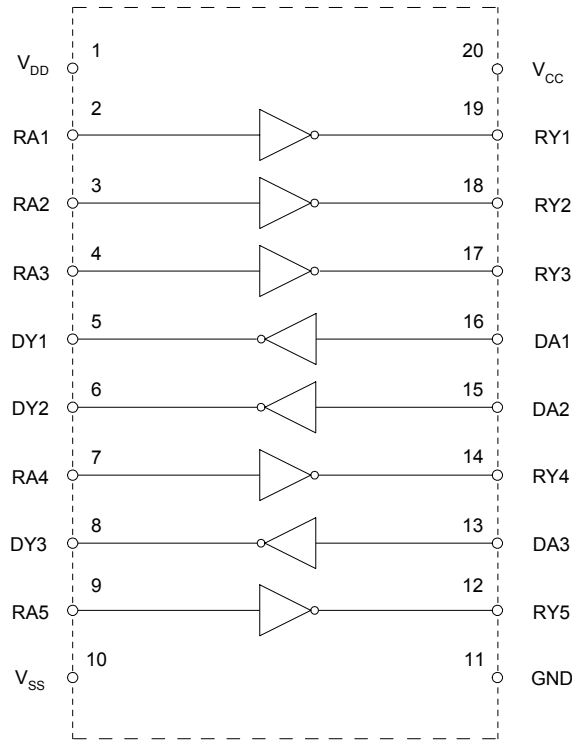
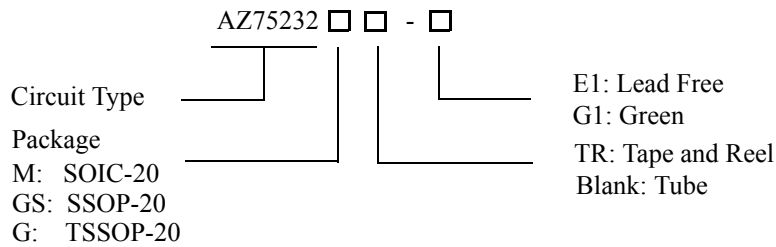

Figure 3. Functional Block Diagram of AZ75232

**Ordering Information**



Package	Temperature Range	Part Number		Marking ID		Packing Type
		Lead Free	Green	Lead Free	Green	
SOIC-20	-40 to 85°C	AZ75232M-E1	AZ75232M-G1	AZ75232M-E1	AZ75232M-G1	Tube
		AZ75232MTR-E1	AZ75232MTR-G1	AZ75232M-E1	AZ75232M-G1	Tape & Reel
SSOP-20	-40 to 85°C	AZ75232GS-E1	AZ75232GS-G1	AZ75232GS-E1	AZ75232GS-G1	Tube
		AZ75232GSTR-E1	AZ75232GSTR-G1	AZ75232GS-E1	AZ75232GS-G1	Tape & Reel
TSSOP-20	-40 to 85°C	AZ75232G-E1	AZ75232G-G1	232GE	232GG	Tube
		AZ75232GTR-E1	AZ75232GTR-G1	232GE	232GG	Tape & Reel

BCD Semiconductor's Pb-free products, as designated with "E1" suffix in the part number, are RoHS compliant. Products with "G1" suffix are available in green packages.

**MULTIPLE RS-232 DRIVERS AND RECEIVERS****AZ75232****Absolute Maximum Ratings (Note 1)**

Parameter	Symbol	Value		Unit
Supply Voltage	$V_{DD}$	15		V
	$V_{SS}$	-15		
	$V_{CC}$	7		
Input Voltage Range	$V_I$	Driver	-15 to 7	V
		Receiver	-30 to 30	
Power Dissipation ( $T_A=25^\circ\text{C}$ )	$P_D$	SOIC-20	1340	mW
		SSOP-20	1210	
		TSSOP-20	1100	
Driver Output Voltage Range	$V_O$	-15 to 15		V
Receiver Low-Level Output Current	$I_{OL}$	20		mA
Operating Junction Temperature	$T_J$	150		$^\circ\text{C}$
Storage Temperature Range	$T_{STG}$	-65 to 150		$^\circ\text{C}$
Lead Temperature (Soldering, 10sec)	$T_{LEAD}$	260		$^\circ\text{C}$

Note 1: Stresses greater than those listed under "Absolute Maximum Ratings" may cause permanent damage to the device. These are stress ratings only, and functional operation of the device at these or any other conditions beyond those indicated under "Recommended Operating Conditions" is not implied. Exposure to "Absolute Maximum Ratings" for extended periods may affect device reliability.

**Recommended Operating Conditions**

Parameter	Symbol	Min	Max	Unit
Supply Voltage	$V_{DD}$	7.5	15	V
	$V_{SS}$	-15	-7.5	
	$V_{CC}$	4.5	5.5	
High-Level Input Voltage (Driver Only)	$V_{IH}$	1.9		V
Low-Level Input Voltage (Driver Only)	$V_{IL}$		0.8	V
High-Level Output Current	Driver		-6	mA
	Receiver		-0.5	
Low-Level Output Current	Driver		6	mA
	Receiver		16	
Operating Temperature Range	$T_A$	-40	85	$^\circ\text{C}$



**MULTIPLE RS-232 DRIVERS AND RECEIVERS**

**AZ75232**

**Electrical Characteristics**

(T<sub>A</sub>=25°C, unless otherwise specified.)

Parameter	Symbol	Conditions	Min	Typ	Max	Unit	
<b>VOLTAGE SUPPLY SECTION (V<sub>CC</sub>=5V, V<sub>DD</sub>=9V, V<sub>SS</sub>=-9V, unless otherwise specified)</b>							
Supply Current from V <sub>DD</sub>	I <sub>DD</sub>	All inputs at 1.9V, no load	V <sub>DD</sub> =9V, V <sub>SS</sub> =-9V			15	mA
			V <sub>DD</sub> =12V, V <sub>SS</sub> =-12V			19	
			V <sub>DD</sub> =15V, V <sub>SS</sub> =-15V			25	
		All inputs at 0.8V, no load	V <sub>DD</sub> =9V, V <sub>SS</sub> =-9V			4.5	
			V <sub>DD</sub> =12V, V <sub>SS</sub> =-12V			5.5	
			V <sub>DD</sub> =15V, V <sub>SS</sub> =-15V			9	
Supply Current from V <sub>SS</sub>	I <sub>SS</sub>	All inputs at 1.9V, no load	V <sub>DD</sub> =9V, V <sub>SS</sub> =-9V			-15	mA
			V <sub>DD</sub> =12V, V <sub>SS</sub> =-12V			-19	
			V <sub>DD</sub> =15V, V <sub>SS</sub> =-15V			-25	
		All inputs at 0.8V, no load	V <sub>DD</sub> =9V, V <sub>SS</sub> =-9V			-3.2	
			V <sub>DD</sub> =12V, V <sub>SS</sub> =-12V			-3.2	
			V <sub>DD</sub> =15V, V <sub>SS</sub> =-15V			-3.2	
Supply Current from V <sub>CC</sub>	I <sub>CC</sub>	All inputs at 5V, no load, V <sub>CC</sub> =5V			30	mA	
<b>DRIVER SECTION (V<sub>CC</sub>=5V, V<sub>DD</sub>=9V, V<sub>SS</sub>=-9V, unless otherwise specified)</b>							
High-Level Output Voltage	V <sub>OH</sub>	V <sub>IL</sub> =0.8V, R <sub>L</sub> =3kΩ	6	7.5		V	
Low-Level Output Voltage	V <sub>OL</sub>	V <sub>IH</sub> =1.9V, R <sub>L</sub> =3kΩ		-7.5	-6	V	
High-Level Input Current	I <sub>IH</sub>	V <sub>I</sub> =5V			10	μA	
Low-Level Input Current	I <sub>IL</sub>	V <sub>I</sub> =0V			-1.6	mA	
High-Level Short-Circuit Output Current	I <sub>OS(H)</sub>	V <sub>IL</sub> =0.8V, V <sub>O</sub> =0V	-4.5	-12	-19.5	mA	
Low-Level Short-Circuit Output Current	I <sub>OS(L)</sub>	V <sub>IH</sub> =2V, V <sub>O</sub> =0V	4.5	12	19.5	mA	
Output Resistance	r <sub>O</sub>	V <sub>CC</sub> =V <sub>DD</sub> =V <sub>SS</sub> =0, V <sub>O</sub> =-2V to 2V	300			Ω	
<b>DRIVER SECTION (V<sub>CC</sub>=5V, V<sub>DD</sub>=12V, V<sub>SS</sub>=-12V, unless otherwise specified)</b>							
Propagation Delay Time Low to High Level Output	t <sub>PLH</sub>	R <sub>L</sub> =3kΩ to 7kΩ, C <sub>L</sub> =15pF		315	500	ns	
Propagation Delay Time High to Low Level Output	t <sub>PHL</sub>	R <sub>L</sub> =3kΩ to 7kΩ, C <sub>L</sub> =15pF		75	175	ns	
Transition Time Low to High Level Output	t <sub>TLH</sub>	R <sub>L</sub> =3kΩ to 7kΩ	C <sub>L</sub> =15pF		60	100	ns
			C <sub>L</sub> =2500pF (Note 2)		1.7	2.5	μs
Transition Time High to Low Level Output	t <sub>THL</sub>	R <sub>L</sub> =3kΩ to 7kΩ	C <sub>L</sub> =15pF		40	75	ns
			C <sub>L</sub> =2500pF (Note 2)		1.5	2.5	μs



**MULTIPLE RS-232 DRIVERS AND RECEIVERS**

**AZ75232**

**Electrical Characteristics (Continued)**

( $T_A=25^{\circ}\text{C}$ , unless otherwise specified.)

Parameter	Symbol	Conditions	Min	Typ	Max	Unit	
<b>RECEIVER SECTION (<math>V_{CC}=5\text{V}</math>, <math>V_{DD}=9\text{V}</math>, <math>V_{SS}=-9\text{V}</math>, unless otherwise specified)</b>							
Positive-Going Input Threshold Voltage	$V_{IT+}$		1.75	1.9	2.3	V	
		$T_A = -40$ to $85^{\circ}\text{C}$	1.55		2.3	V	
Negative-Going Input Threshold Voltage	$V_{IT-}$		0.75	0.97	1.25	V	
Input Hysteresis Voltage	$V_{HYS}$		0.5			V	
High-Level Output Voltage	$V_{OH}$	$I_{OH}=-0.5\text{mA}$	$V_{IH}=0.75\text{V}$	2.6	4	5	V
			Input Open	2.6			
Low-Level Output Voltage	$V_{OL}$	$I_{OL}=10\text{mA}$ , $V_I=3\text{V}$		0.2	0.45	V	
High-Level Input Current	$I_{IH}$	$V_I=25\text{V}$	3.6		8.3	mA	
		$V_I=3\text{V}$	0.43				
Low-Level Input Current	$I_{IL}$	$V_I=-25\text{V}$	-3.6		-8.3	mA	
		$V_I=-3\text{V}$	-0.43				
Short-Circuit Output Current	$I_{OS}$	$V_I=0.8\text{V}$		-3.4	-12	mA	
<b>RECEIVER SECTION (<math>V_{CC}=5\text{V}</math>, <math>V_{DD}=12\text{V}</math>, <math>V_{SS}=-12\text{V}</math>, unless otherwise specified)</b>							
Propagation Delay Time Low to High Level Output	$t_{PLH}$	$R_L=5\text{k}\Omega$ , $C_L=50\text{pF}$		105	250	ns	
		$R_L=1.5\text{k}\Omega$ , $C_L=15\text{pF}$		100	160		
Propagation Delay Time High to Low Level Output	$t_{PHL}$	$R_L=5\text{k}\Omega$ , $C_L=50\text{pF}$		60	150	ns	
		$R_L=1.5\text{k}\Omega$ , $C_L=15\text{pF}$		42	100		
Transition Time Low to High Level Output	$t_{TLH}$	$R_L=5\text{k}\Omega$ , $C_L=50\text{pF}$		170	350	ns	
		$R_L=1.5\text{k}\Omega$ , $C_L=15\text{pF}$		90	175		
Transition Time High to Low Level Output	$t_{THL}$	$R_L=5\text{k}\Omega$ , $C_L=50\text{pF}$		16	60	ns	
		$R_L=1.5\text{k}\Omega$ , $C_L=15\text{pF}$		15	50		

Note 2: Measured between -3V and 3V points of the output waveform (EIA/TIA-232-F conditions); all unused inputs are tied either high or low.



**Typical Performance Characteristics**

**Driver Section**

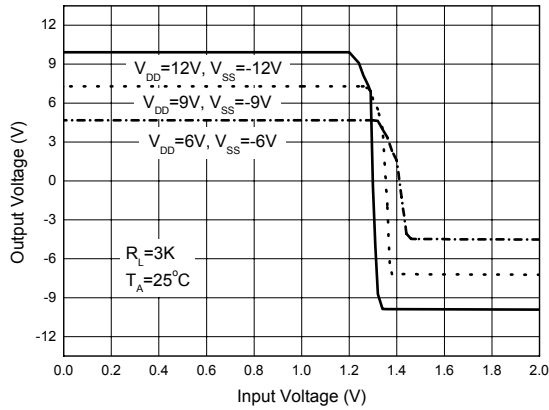

Figure 4. Voltage Transfer Characteristics

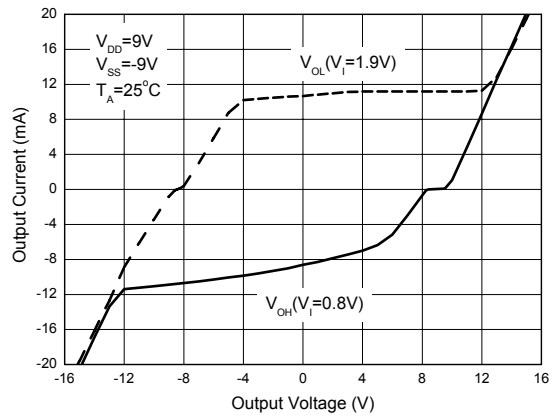

Figure 5. Output Current vs. Output Voltage

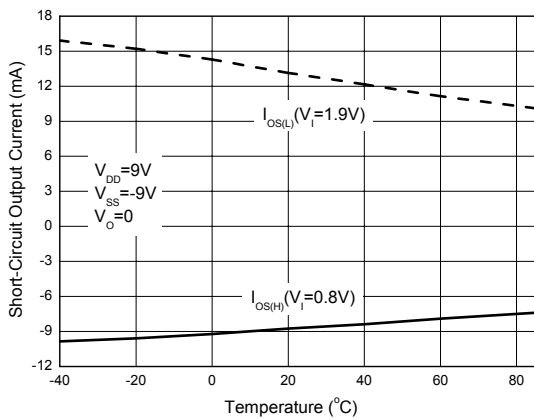

Figure 6. Short-Circuit Output Current vs. Temperature

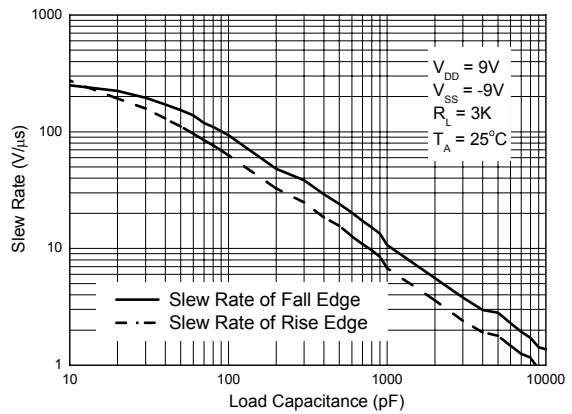

Figure 7. Slew Rate vs. Load Capacitance



**Typical Performance Characteristics (Continued)**

**Receiver Section**

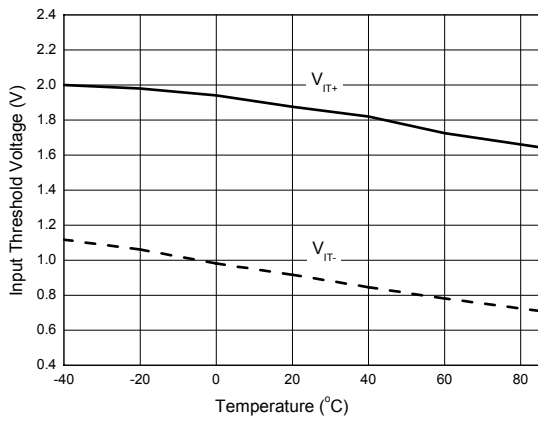

Figure 8. Input Threshold Voltage vs. Temperature

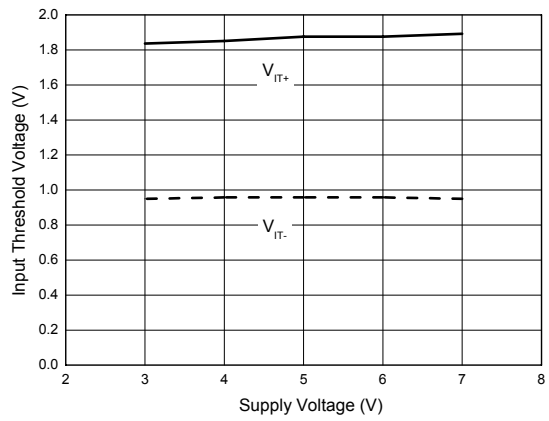

Figure 9. Input Threshold Voltage vs. Supply Voltage

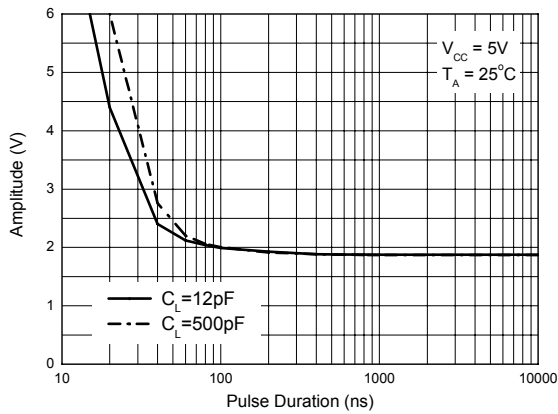

Figure 10. Noise Rejection



**Typical Application**

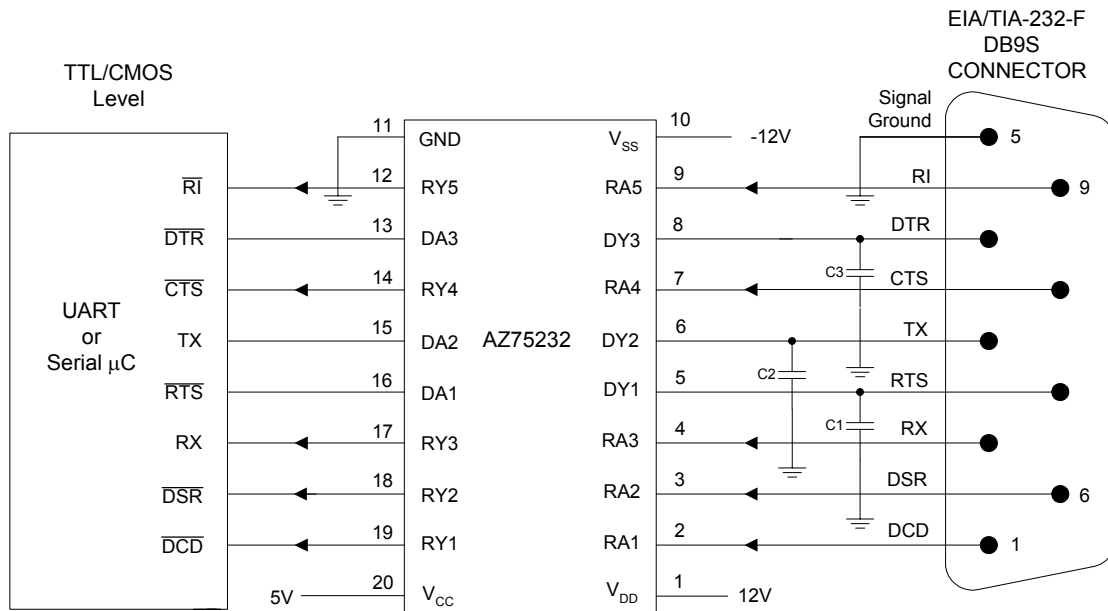

Figure 11. Typical Application of AZ75232



**MULTIPLE RS-232 DRIVERS AND RECEIVERS**

**AZ75232**

**Mechanical Dimensions**

**SOIC-20**

**Unit: mm(inch)**

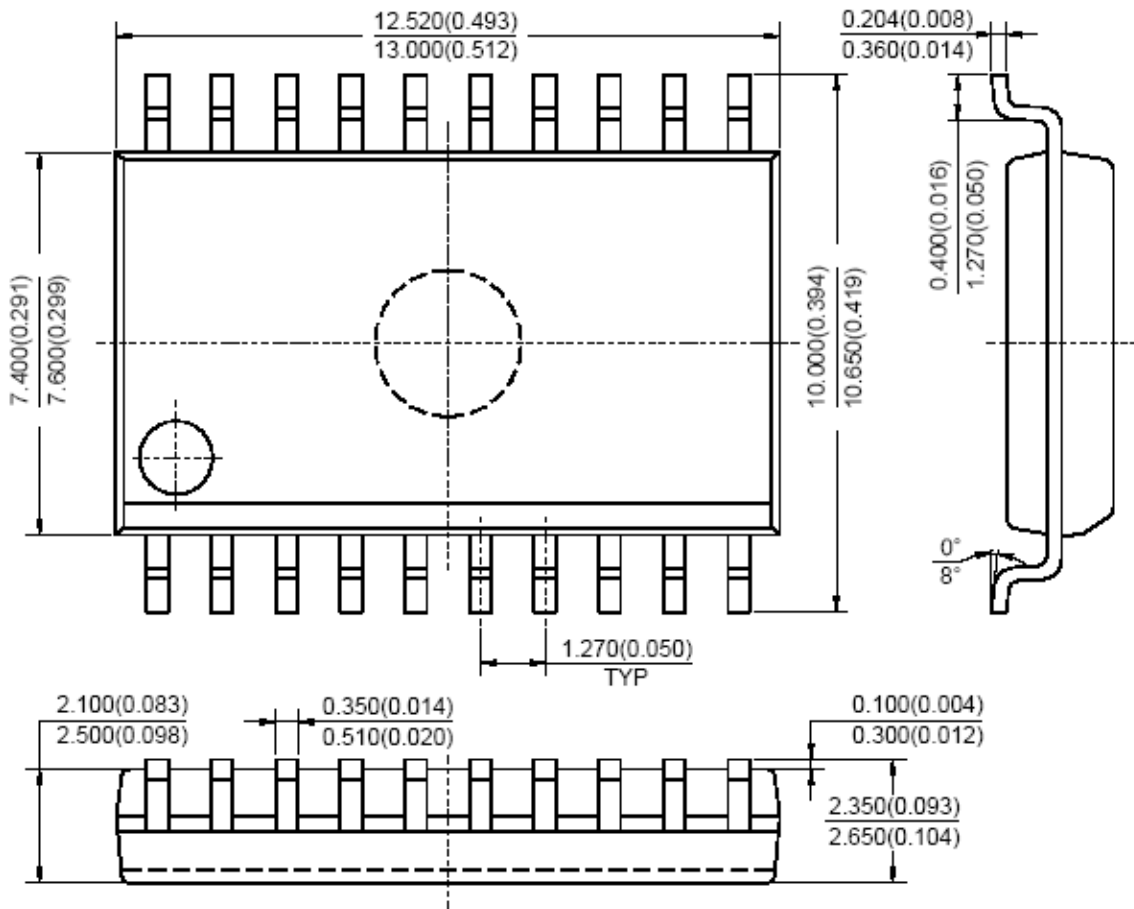

Note: Eject hole, oriented hole and mold mark is optional.



**MULTIPLE RS-232 DRIVERS AND RECEIVERS**

**AZ75232**

**Mechanical Dimensions (Continued)**

**SSOP-20**

**Unit: mm(inch)**

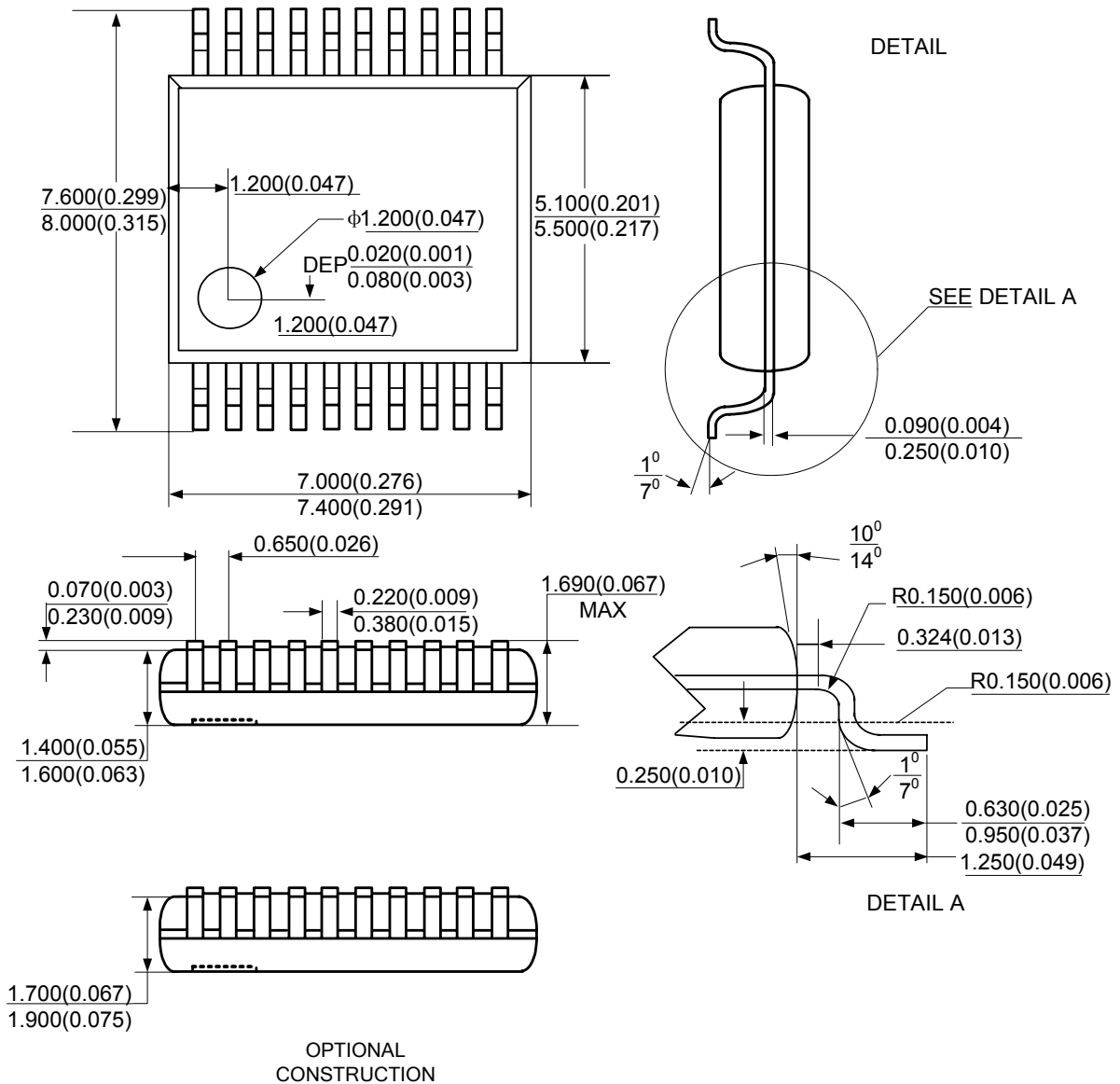

Note: Eject hole, oriented hole and mold mark is optional



**MULTIPLE RS-232 DRIVERS AND RECEIVERS**

**AZ75232**

**Mechanical Dimensions**

**TSSOP-20**

**Unit: mm(inch)**

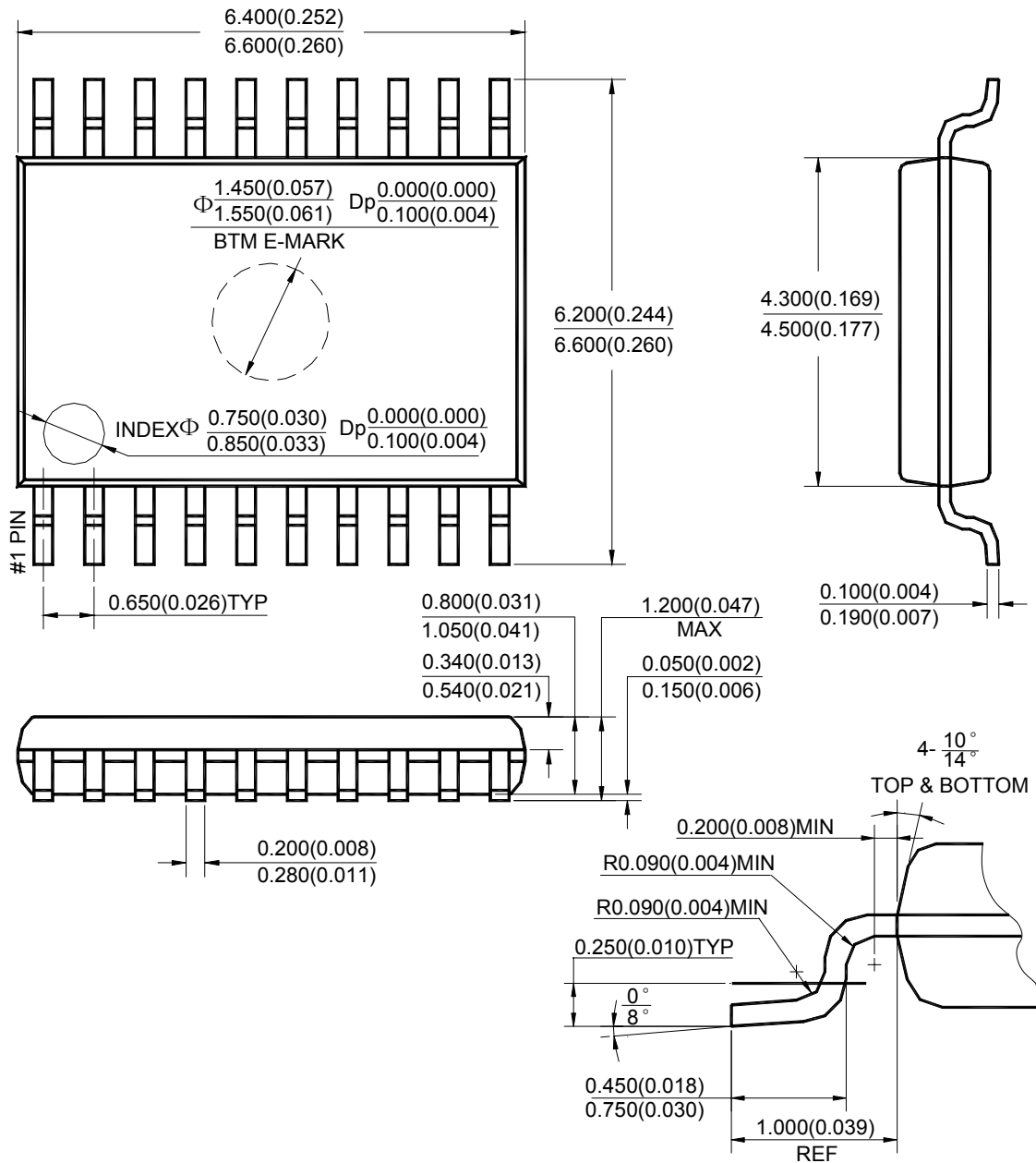

Note: Eject hole, oriented hole and mold mark is optional.



## **BCD Semiconductor Manufacturing Limited**

<http://www.bcdsemi.com>

### **IMPORTANT NOTICE**

BCD Semiconductor Manufacturing Limited reserves the right to make changes without further notice to any products or specifications herein. BCD Semiconductor Manufacturing Limited does not assume any responsibility for use of any its products for any particular purpose, nor does BCD Semiconductor Manufacturing Limited assume any liability arising out of the application or use of any its products or circuits. BCD Semiconductor Manufacturing Limited does not convey any license under its patent rights or other rights nor the rights of others.

---

#### **MAIN SITE**

##### **- Headquarters**

##### **BCD Semiconductor Manufacturing Limited**

No. 1600, Zi Xing Road, Shanghai Zizhu Science-based Industrial Park, 200241, China  
Tel: +86-21-24162266, Fax: +86-21-24162277

##### **- Wafer Fab**

##### **Shanghai SIM-BCD Semiconductor Manufacturing Co., Ltd.**

800 Yi Shan Road, Shanghai 200233, China  
Tel: +86-21-6485 1491, Fax: +86-21-5450 0008

#### **REGIONAL SALES OFFICE**

##### **Shenzhen Office**

##### **Shanghai SIM-BCD Semiconductor Manufacturing Co., Ltd., Shenzhen Office**

Unit A Room 1203, Skyworth Bldg., Gaoxin Ave. 1.S., Nanshan District, Shenzhen, China  
Tel: +86-755-8826 7951  
Fax: +86-755-8826 7865

##### **Taiwan Office**

##### **BCD Semiconductor (Taiwan) Company Limited**

4F, 298-1, Rui Guang Road, Nei-Hu District, Taipei, Taiwan  
Tel: +886-2-2656 2808  
Fax: +886-2-2656 2806

##### **USA Office**

##### **BCD Semiconductor Corp.**

30920 Huntwood Ave. Hayward, CA 94544, USA  
Tel : +1-510-324-2988  
Fax: +1-510-324-2788

Компания «Life Electronics» занимается поставками электронных компонентов импортного и отечественного производства от производителей и со складов крупных дистрибьюторов Европы, Америки и Азии.

С конца 2013 года компания активно расширяет линейку поставок компонентов по направлению коаксиальный кабель, кварцевые генераторы и конденсаторы (керамические, пленочные, электролитические), за счёт заключения дистрибьюторских договоров

Мы предлагаем:

- Конкурентоспособные цены и скидки постоянным клиентам.
- Специальные условия для постоянных клиентов.
- Подбор аналогов.
- Поставку компонентов в любых объемах, удовлетворяющих вашим потребностям.
- Приемлемые сроки поставки, возможна ускоренная поставка.
- Доставку товара в любую точку России и стран СНГ.
- Комплексную поставку.
- Работу по проектам и поставку образцов.
- Формирование склада под заказчика.
- Сертификаты соответствия на поставляемую продукцию (по желанию клиента).
- Тестирование поставляемой продукции.
- Поставку компонентов, требующих военную и космическую приемку.
- Входной контроль качества.
- Наличие сертификата ISO.

В составе нашей компании организован Конструкторский отдел, призванный помогать разработчикам, и инженерам.

Конструкторский отдел помогает осуществить:

- Регистрацию проекта у производителя компонентов.
- Техническую поддержку проекта.
- Защиту от снятия компонента с производства.
- Оценку стоимости проекта по компонентам.
- Изготовление тестовой платы монтаж и пусконаладочные работы.



Тел: +7 (812) 336 43 04 (многоканальный)  
Email: [org@lifeelectronics.ru](mailto:org@lifeelectronics.ru)