

Water Cooled Wirewound Resistor



FEATURES

- Direct cooling without heat sink
- Better power / volume ratio
- Non-inductive optional
- 1 WCR = 6 wirewound resistors = 5 thick-film resistors
- Up to 6 resistive functions on 1 WCR tube
- 1 single supply for several functions (snubber and divider)
- Material categorization: for definitions of compliance please see www.vishay.com/doc?99912

RoHS
COMPLIANT

STANDARD ELECTRICAL SPECIFICATIONS

GLOBAL MODEL	POWER RATING ⁽¹⁾ W	RESISTANCE RANGE Ω	TOLERANCE ± %
WCR 30 x 250	1500	4.7 to 56K	5
WCR 38 x 250	2000	4.7 to 56K	5
WCR 38 x 300	2500	4.7 to 56K	5

Note
⁽¹⁾ Water inlet temperature 60 °C with 40 % glycol, flow rate 5 l/min

TECHNICAL SPECIFICATIONS

PARAMETER	UNIT	RESISTOR CHARACTERISTICS
Temperature coefficient	ppm/°C	100 ppm/°C (typical)
Maximum working voltage	V	Up to 3500 V (6600 V on specific request)
Operating temperature range	°C	-55 to +120

GENERAL CHARACTERISTICS

Core	Ceramic
Winding	NiCr alloy fully insulated from water
Hydraulic plugs	Stainless steel (corrosion free)
Coating	Vitreous enamel or silicone coating ⁽¹⁾
Ohmic values	E12 (4.7 Ω to 56 kΩ)
Inductance	Non-inductive type on request
Cooling	Industrial or deionized water; coolant mixtures up to 60 % glycol
Operating pressure	1 bar to 6 bars
Test pressure	10 bars
Flow	5 l/min to 15 l/min
CTI Index	> 600
Creeping distance	On request
Clearance distance	On request
Electrical connections	M3 screw and nut (other on request)
Mounting	Vertically (recommended)
Overload	2 x P _n 10 s (θ ₆₀ °C at 5 l/min)
Endurance	1000 cycles P _n 30 s/30 s; variation < 5 %
Pressure drop	0.8 bar for WCR 30 mm x 250 mm; 0.25 bar for WCR 38 mm x 250 mm and WCR 38 mm x 300 mm (flow rate 10 l/min)

Note
⁽¹⁾ For PD reason (withstand)

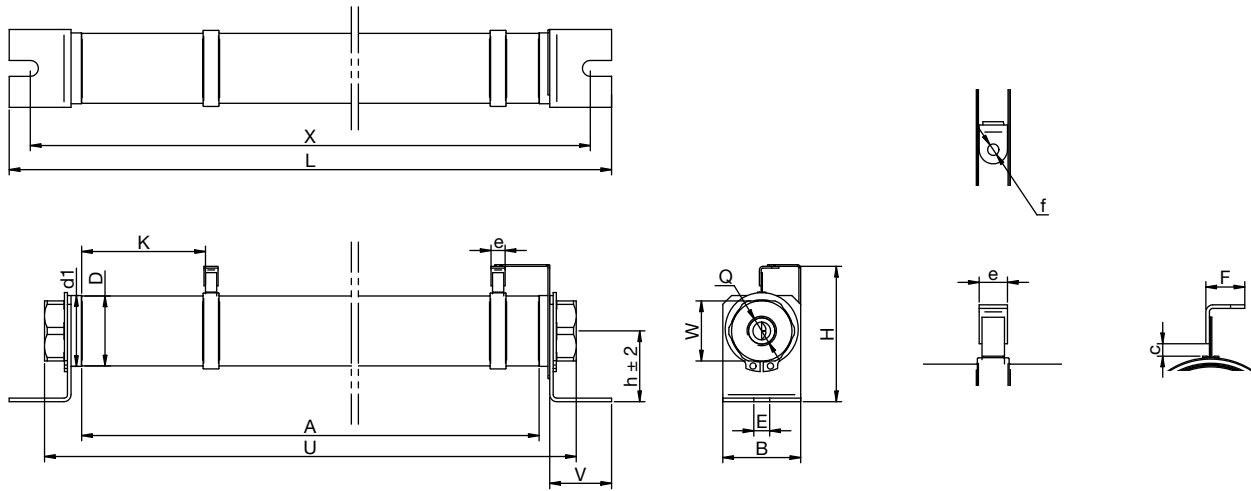
DIMENSIONS in millimeters

TYPE	30 x 250	38 x 250	38 x 300
Water pipe diameter	Ø 8	Ø 10	Ø 10
A	250	250	300
B + 0.5 / - 0	32	44	44
c	3.5	3.5	3.5
C	14.5	14.5	14.5
D _{max.}	35	43	43
d1	32	40	40
E	7	9	9
e	8	8	8
f	Ø 3.2	Ø 3.2	Ø 3.2
F	11	11	11
H _{max.}	54	80	80
h ± 2	25	40	40
K	(1)	(1)	(1)
L _{max.}	304	335	385
Ø	30	38	38
Q	G 3/8 ⁽²⁾	G 3/8 ⁽²⁾	G 3/8 ⁽²⁾
U	288	292	342
V	20	35	35
W	24	34	34
X ± 2	286	308	358
Weight	1 kg	1.3 kg	1.5 kg

Notes

- (1) Creeping / clearance on request
- (2) Other hydraulic connections on request

SPECIFIC CHARACTERISTICS

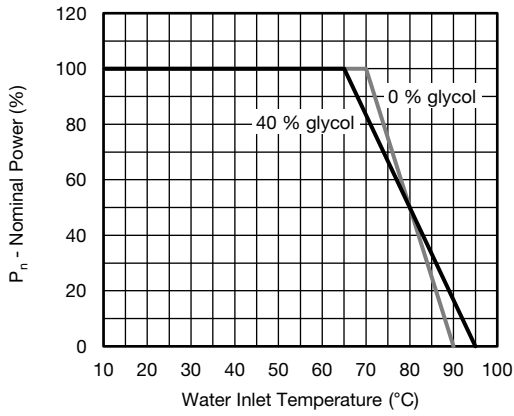

Fig. 1 - Nominal Power Dissipated According to Water Inlet Temperature
 $P_n = f(\text{Water Inlet Temperature})$
 Flow Rate = 5 l/min

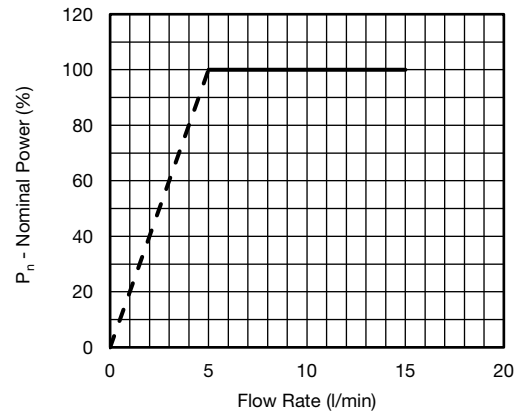

Fig. 2 - Power Dissipated According to the Flow Rate
 $P_n = f(\text{Flow Rate})$
 Temperature = 60 °C

OPTIONS

On request

PART NUMBER INFORMATION				
WCR	38 x 250	A	120 Ω	5 %
MODEL	TYPE	"A" FOR NON-INDUCTIVE	VALUE	TOLERANCE



Disclaimer

ALL PRODUCT, PRODUCT SPECIFICATIONS AND DATA ARE SUBJECT TO CHANGE WITHOUT NOTICE TO IMPROVE RELIABILITY, FUNCTION OR DESIGN OR OTHERWISE.

Vishay Intertechnology, Inc., its affiliates, agents, and employees, and all persons acting on its or their behalf (collectively, "Vishay"), disclaim any and all liability for any errors, inaccuracies or incompleteness contained in any datasheet or in any other disclosure relating to any product.

Vishay makes no warranty, representation or guarantee regarding the suitability of the products for any particular purpose or the continuing production of any product. To the maximum extent permitted by applicable law, Vishay disclaims (i) any and all liability arising out of the application or use of any product, (ii) any and all liability, including without limitation special, consequential or incidental damages, and (iii) any and all implied warranties, including warranties of fitness for particular purpose, non-infringement and merchantability.

Statements regarding the suitability of products for certain types of applications are based on Vishay's knowledge of typical requirements that are often placed on Vishay products in generic applications. Such statements are not binding statements about the suitability of products for a particular application. It is the customer's responsibility to validate that a particular product with the properties described in the product specification is suitable for use in a particular application. Parameters provided in datasheets and/or specifications may vary in different applications and performance may vary over time. All operating parameters, including typical parameters, must be validated for each customer application by the customer's technical experts. Product specifications do not expand or otherwise modify Vishay's terms and conditions of purchase, including but not limited to the warranty expressed therein.

Except as expressly indicated in writing, Vishay products are not designed for use in medical, life-saving, or life-sustaining applications or for any other application in which the failure of the Vishay product could result in personal injury or death. Customers using or selling Vishay products not expressly indicated for use in such applications do so at their own risk. Please contact authorized Vishay personnel to obtain written terms and conditions regarding products designed for such applications.

No license, express or implied, by estoppel or otherwise, to any intellectual property rights is granted by this document or by any conduct of Vishay. Product names and markings noted herein may be trademarks of their respective owners.

Material Category Policy

Vishay Intertechnology, Inc. hereby certifies that all its products that are identified as RoHS-Compliant fulfill the definitions and restrictions defined under Directive 2011/65/EU of The European Parliament and of the Council of June 8, 2011 on the restriction of the use of certain hazardous substances in electrical and electronic equipment (EEE) - recast, unless otherwise specified as non-compliant.

Please note that some Vishay documentation may still make reference to RoHS Directive 2002/95/EC. We confirm that all the products identified as being compliant to Directive 2002/95/EC conform to Directive 2011/65/EU.

Vishay Intertechnology, Inc. hereby certifies that all its products that are identified as Halogen-Free follow Halogen-Free requirements as per JEDEC JS709A standards. Please note that some Vishay documentation may still make reference to the IEC 61249-2-21 definition. We confirm that all the products identified as being compliant to IEC 61249-2-21 conform to JEDEC JS709A standards.

Компания «Life Electronics» занимается поставками электронных компонентов импортного и отечественного производства от производителей и со складов крупных дистрибьюторов Европы, Америки и Азии.

С конца 2013 года компания активно расширяет линейку поставок компонентов по направлению коаксиальный кабель, кварцевые генераторы и конденсаторы (керамические, пленочные, электролитические), за счёт заключения дистрибьюторских договоров

Мы предлагаем:

- Конкуренеспособные цены и скидки постоянным клиентам.
- Специальные условия для постоянных клиентов.
- Подбор аналогов.
- Поставку компонентов в любых объемах, удовлетворяющих вашим потребностям.
- Приемлемые сроки поставки, возможна ускоренная поставка.
- Доставку товара в любую точку России и стран СНГ.
- Комплексную поставку.
- Работу по проектам и поставку образцов.
- Формирование склада под заказчика.
- Сертификаты соответствия на поставляемую продукцию (по желанию клиента).
- Тестирование поставляемой продукции.
- Поставку компонентов, требующих военную и космическую приемку.
- Входной контроль качества.
- Наличие сертификата ISO.

В составе нашей компании организован Конструкторский отдел, призванный помогать разработчикам, и инженерам.

Конструкторский отдел помогает осуществить:

- Регистрацию проекта у производителя компонентов.
- Техническую поддержку проекта.
- Защиту от снятия компонента с производства.
- Оценку стоимости проекта по компонентам.
- Изготовление тестовой платы монтаж и пусконаладочные работы.



Тел: +7 (812) 336 43 04 (многоканальный)

Email: org@lifeelectronics.ru