

**SYSMAC**  
**Programmable Controllers**  
**C200H**  
**(CPU01-E/03-E/11-E)**

**INSTALLATION GUIDE**

**OMRON®**



# C200H Programmable Controllers (CPU01-E/03-E/11-E)

## Installation Guide

Revised January 2001

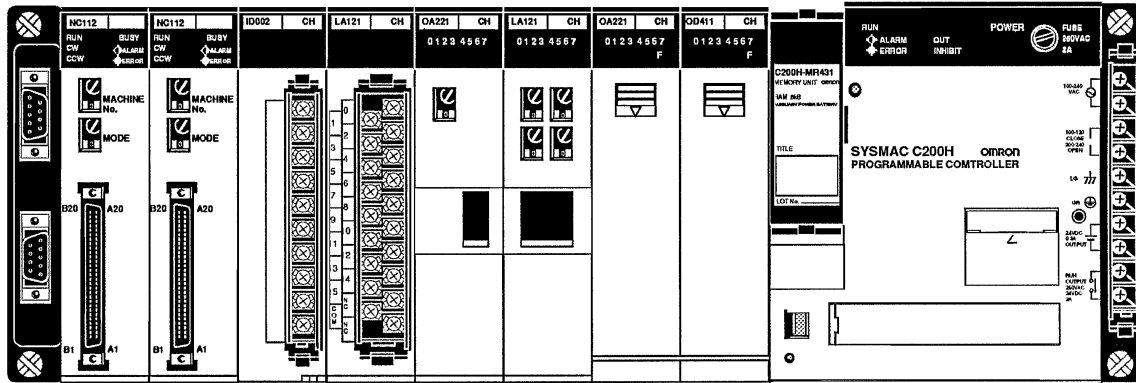

# Terms and Conditions of Sale

1. **Offer; Acceptance.** These terms and conditions (these "Terms") are deemed part of all quotes, agreements, purchase orders, acknowledgments, price lists, catalogs, manuals, brochures and other documents, whether electronic or in writing, relating to the sale of products or services (collectively, the "Products") by Omron Electronics LLC and its subsidiary companies ("Omron"). Omron objects to any terms or conditions proposed in Buyer's purchase order or other documents which are inconsistent with, or in addition to, these Terms.
2. **Prices; Payment Terms.** All prices stated are current, subject to change without notice by Omron. Omron reserves the right to increase or decrease prices on any unshipped portions of outstanding orders. Payments for Products are due net 30 days unless otherwise stated in the invoice.
3. **Discounts.** Cash discounts, if any, will apply only on the net amount of invoices sent to Buyer after deducting transportation charges, taxes and duties, and will be allowed only if (i) the invoice is paid according to Omron's payment terms and (ii) Buyer has no past due amounts.
4. **Interest.** Omron, at its option, may charge Buyer 1-1/2% interest per month or the maximum legal rate, whichever is less, on any balance not paid within the stated terms.
5. **Orders.** Omron will accept no order less than \$200 net billing.
6. **Governmental Approvals.** Buyer shall be responsible for, and shall bear all costs involved in, obtaining any government approvals required for the importation or sale of the Products.
7. **Taxes.** All taxes, duties and other governmental charges (other than general real property and income taxes), including any interest or penalties thereon, imposed directly or indirectly on Omron or required to be collected directly or indirectly by Omron for the manufacture, production, sale, delivery, importation, consumption or use of the Products sold hereunder (including customs duties and sales, excise, use, turnover and license taxes) shall be charged to and remitted by Buyer to Omron.
8. **Financial.** If the financial position of Buyer at any time becomes unsatisfactory to Omron, Omron reserves the right to stop shipments or require satisfactory security or payment in advance. If Buyer fails to make payment or otherwise comply with these Terms or any related agreement, Omron may (without liability and in addition to other remedies) cancel any unshipped portion of Products sold hereunder and stop any Products in transit until Buyer pays all amounts, including amounts payable hereunder, whether or not then due, which are owing to it by Buyer. Buyer shall in any event remain liable for all unpaid accounts.
9. **Cancellation; Etc.** Orders are not subject to rescheduling or cancellation unless Buyer indemnifies Omron against all related costs or expenses.
10. **Force Majeure.** Omron shall not be liable for any delay or failure in delivery resulting from causes beyond its control, including earthquakes, fires, floods, strikes or other labor disputes, shortage of labor or materials, accidents to machinery, acts of sabotage, riots, delay in or lack of transportation or the requirements of any government authority.
11. **Shipping; Delivery.** Unless otherwise expressly agreed in writing by Omron:
  - a. Shipments shall be by a carrier selected by Omron; Omron will not drop ship except in "break down" situations.
  - b. Such carrier shall act as the agent of Buyer and delivery to such carrier shall constitute delivery to Buyer;
  - c. All sales and shipments of Products shall be FOB shipping point (unless otherwise stated in writing by Omron), at which point title and risk of loss shall pass from Omron to Buyer; provided that Omron shall retain a security interest in the Products until the full purchase price is paid;
  - d. Delivery and shipping dates are estimates only; and
  - e. Omron will package Products as it deems proper for protection against normal handling and extra charges apply to special conditions.
12. **Claims.** Any claim by Buyer against Omron for shortage or damage to the Products occurring before delivery to the carrier must be presented in writing to Omron within 30 days of receipt of shipment and include the original transportation bill signed by the carrier noting that the carrier received the Products from Omron in the condition claimed.
13. **Warranties.** (a) **Exclusive Warranty.** Omron's exclusive warranty is that the Products will be free from defects in materials and workmanship for a period of twelve months from the date of sale by Omron (or such other period expressed in writing by Omron). Omron disclaims all other warranties, express or implied. (b) **Limitations.** OMRON MAKES NO WARRANTY OR REPRESENTATION, EXPRESS OR IMPLIED, ABOUT NON-INFRINGEMENT, MERCHANTABILITY OR FITNESS FOR A PARTICULAR PURPOSE OF THE PRODUCTS. BUYER ACKNOWLEDGES THAT IT ALONE HAS DETERMINED THAT THE PRODUCTS WILL SUITABLY MEET THE REQUIREMENTS OF THEIR INTENDED USE. Omron further disclaims all warranties and responsibility of any type for claims or expenses based on infringement by the Products or otherwise of any intellectual property right. (c) **Buyer Remedy.** Omron's sole obligation hereunder shall be, at Omron's election, to (i) replace (in the form originally shipped with Buyer responsible for labor charges for removal or replacement thereof) the non-complying Product, (ii) repair the non-complying Product, or (iii) repay or credit Buyer an amount equal to the purchase price of the non-complying Product; provided that in no event shall Omron be responsible for warranty, repair, indemnity or any other claims or expenses regarding the Products unless Omron's analysis confirms that the Products were properly handled, stored, installed and maintained and not subject to contamination, abuse, misuse or inappropriate modification. Return of any Products by Buyer must be approved in writing by Omron before shipment. Omron Companies shall not be liable for the suitability or unsuitability or the results from the use of Products in combination with any electrical or electronic components, circuits, system assemblies or any other materials or substances or environments. Any advice, recommendations or information given orally or in writing, are not to be construed as an amendment or addition to the above warranty. See <http://oeweb.omron.com> or contact your Omron representative for published information.
14. **Limitation on Liability; Etc.** OMRON COMPANIES SHALL NOT BE LIABLE FOR SPECIAL, INDIRECT, INCIDENTAL, OR CONSEQUENTIAL DAMAGES, LOSS OF PROFITS OR PRODUCTION OR COMMERCIAL LOSS IN ANY WAY CONNECTED WITH THE PRODUCTS, WHETHER SUCH CLAIM IS BASED IN CONTRACT, WARRANTY, NEGLIGENCE OR STRICT LIABILITY. Further, in no event shall liability of Omron Companies exceed the individual price of the Product on which liability is asserted.
15. **Indemnities.** Buyer shall indemnify and hold harmless Omron Companies and their employees from and against all liabilities, losses, claims, costs and expenses (including attorney's fees and expenses) related to any claim, investigation, litigation or proceeding (whether or not Omron is a party) which arises or is alleged to arise from Buyer's acts or omissions under these Terms or in any way with respect to the Products. Without limiting the foregoing, Buyer (at its own expense) shall indemnify and hold harmless Omron and defend or settle any action brought against such Companies to the extent based on a claim that any Product made to Buyer specifications infringed intellectual property rights of another party.
16. **Property; Confidentiality.** Any intellectual property in the Products is the exclusive property of Omron Companies and Buyer shall not attempt to duplicate it in any way without the written permission of Omron. Notwithstanding any charges to Buyer for engineering or tooling, all engineering and tooling shall remain the exclusive property of Omron. All information and materials supplied by Omron to Buyer relating to the Products are confidential and proprietary, and Buyer shall limit distribution thereof to its trusted employees and strictly prevent disclosure to any third party.
17. **Export Controls.** Buyer shall comply with all applicable laws, regulations and licenses regarding (i) export of products or information; (ii) sale of products to "forbidden" or other proscribed persons; and (iii) disclosure to non-citizens of regulated technology or information.
18. **Miscellaneous.** (a) **Waiver.** No failure or delay by Omron in exercising any right and no course of dealing between Buyer and Omron shall operate as a waiver of rights by Omron. (b) **Assignment.** Buyer may not assign its rights hereunder without Omron's written consent. (c) **Law.** These Terms are governed by the law of the jurisdiction of the home office of the Omron company from which Buyer is purchasing the Products (without regard to conflict of law principles). (d) **Amendment.** These Terms constitute the entire agreement between Buyer and Omron relating to the Products, and no provision may be changed or waived unless in writing signed by the parties. (e) **Severability.** If any provision hereof is rendered ineffective or invalid, such provision shall not invalidate any other provision. (f) **Setoff.** Buyer shall have no right to set off any amounts against the amount owing in respect of this invoice. (g) **Definitions.** As used herein, "including" means "including without limitation"; and "Omron Companies" (or similar words) mean Omron Corporation and any direct or indirect subsidiary or affiliate thereof.

## Certain Precautions on Specifications and Use

1. **Suitability of Use.** Omron Companies shall not be responsible for conformity with any standards, codes or regulations which apply to the combination of the Product in the Buyer's application or use of the Product. At Buyer's request, Omron will provide applicable third party certification documents identifying ratings and limitations of use which apply to the Product. This information by itself is not sufficient for a complete determination of the suitability of the Product in combination with the end product, machine, system, or other application or use. Buyer shall be solely responsible for determining appropriateness of the particular Product with respect to Buyer's application, product or system. Buyer shall take application responsibility in all cases but the following is a non-exhaustive list of applications for which particular attention must be given:
  - (i) Outdoor use, uses involving potential chemical contamination or electrical interference, or conditions or uses not described in this document.
  - (ii) Use in consumer products or any use in significant quantities.
  - (iii) Energy control systems, combustion systems, railroad systems, aviation systems, medical equipment, amusement machines, vehicles, safety equipment, and installations subject to separate industry or government regulations.
  - (iv) Systems, machines and equipment that could present a risk to life or property. Please know and observe all prohibitions of use applicable to this Product.

NEVER USE THE PRODUCT FOR AN APPLICATION INVOLVING SERIOUS RISK TO LIFE OR PROPERTY OR IN LARGE QUANTITIES WITHOUT ENSURING THAT THE SYSTEM AS A WHOLE HAS BEEN DESIGNED TO ADDRESS THE RISKS, AND THAT THE OMRON'S PRODUCT IS PROPERLY RATED AND INSTALLED FOR THE INTENDED USE WITHIN THE OVERALL EQUIPMENT OR SYSTEM.
2. **Programmable Products.** Omron Companies shall not be responsible for the user's programming of a programmable Product, or any consequence thereof.
3. **Performance Data.** Data presented in Omron Company websites, catalogs and other materials is provided as a guide for the user in determining suitability and does not constitute a warranty. It may represent the result of Omron's test conditions, and the user must correlate it to actual application requirements. Actual performance is subject to the Omron's Warranty and Limitations of Liability.
4. **Change in Specifications.** Product specifications and accessories may be changed at any time based on improvements and other reasons. It is our practice to change part numbers when published ratings or features are changed, or when significant construction changes are made. However, some specifications of the Product may be changed without any notice. When in doubt, special part numbers may be assigned to fix or establish key specifications for your application. Please consult with your Omron's representative at any time to confirm actual specifications of purchased Product.
5. **Errors and Omissions.** Information presented by Omron Companies has been checked and is believed to be accurate; however, no responsibility is assumed for clerical, typographical or proofreading errors or omissions.

## **Notice:**

OMRON products are manufactured for use according to proper procedures by a qualified operator and only for the purposes described in this manual.

The following conventions are used to indicate and classify precautions in this manual. Always heed the information provided with them. Failure to heed precautions can result in injury to people or damage to property.



### **DANGER**

Indicates an imminently hazardous situation which, if not avoided, will result in death or serious injury.



### **WARNING**

Indicates a potentially hazardous situation which, if not avoided, could result in death or serious injury.



### **Caution**

Indicates a potentially hazardous situation which, if not avoided, may result in minor or moderate injury, or property damage.

## **OMRON Product References**

All OMRON products are capitalized in this manual. The word “Unit” is also capitalized when it refers to an OMRON product, regardless of whether or not it appears in the proper name of the product.

The abbreviation “Ch,” which appears in some displays and on some OMRON products, often means “word” and is abbreviated “Wd” in documentation in this sense.

The abbreviation “PC” means Programmable Controller and is not used as an abbreviation for anything else.

## **Visual Aids**

The following headings appear in the left column of the manual to help you locate different types of information.

**Note** Indicates information of particular interest for efficient and convenient operation of the product.

**1, 2, 3...** 1. Indicates lists of one sort or another, such as procedures, checklists, etc.

## **© OMRON, 1990**

All rights reserved. No part of this publication may be reproduced, stored in a retrieval system, or transmitted, in any form, or by any means, mechanical, electronic, photocopying, recording, or otherwise, without the prior written permission of OMRON.

No patent liability is assumed with respect to the use of the information contained herein. Moreover, because OMRON is constantly striving to improve its high-quality products, the information contained in this manual is subject to change without notice. Every precaution has been taken in the preparation of this manual. Nevertheless, OMRON assumes no responsibility for errors or omissions. Neither is any liability assumed for damages resulting from the use of the information contained in this publication.



# TABLE OF CONTENTS

<b>PRECAUTIONS</b> .....	
1 Intended Audience .....	
2 General Precautions .....	
3 Safety Precautions .....	
4 Operating Environment Precautions .....	
5 Application Precautions .....	
<b>SECTION 1</b>	
<b>Introduction</b> .....	
1-1 What is a Control System? .....	
1-2 The Role of the PC .....	
1-3 How Does a PC Work? .....	
<b>SECTION 2</b>	
<b>Description</b> .....	
2-1 CPU Rack .....	
2-2 CPU .....	
2-3 Expansion I/O Rack .....	
2-4 Power Supply .....	
2-5 I/O Units .....	
2-6 Memory Units .....	
<b>SECTION 3</b>	
<b>Assembly Instructions</b> .....	
3-1 Mounting the Units .....	
3-2 Memory Packs .....	
3-3 System Configurations .....	
<b>SECTION 4</b>	
<b>System Connections</b> .....	
4-1 IR Word Allocation .....	
4-2 Remote I/O .....	
4-3 Maximum Current and Power Supplied .....	
4-4 I/O Connections .....	
<b>SECTION 5</b>	
<b>Installation Environment</b> .....	
5-1 Installation Environment .....	
5-2 Mounting Requirements .....	
5-3 Duct Work .....	
5-4 Preventing Noise .....	
<b>SECTION 6</b>	
<b>Power Considerations</b> .....	
6-1 Grounding .....	
6-2 Insulation .....	
6-3 Emergency Stop .....	
6-4 Wiring .....	
<b>SECTION 7</b>	
<b>Safety Considerations</b> .....	
7-1 Interlock Circuits .....	
7-2 Wiring .....	

# TABLE OF CONTENTS

## Appendices

A Inspection and Maintenance .....	
B Specifications .....	
C Standard Models .....	
D Programming Console Operation .....	
E Programming Instructions .....	

<b>Glossary</b> .....	
-----------------------	--

<b>Index</b> .....	
--------------------	--

<b>Revision History</b> .....	
-------------------------------	--



## ***About this Manual:***

This manual explains how to install a C-series C200H Programmable Controller (CPU01-E/03-E/11-E).

**Section 1** is an introduction to Programmable Controllers. General information about what a Programmable Controller can do and how a Programmable Controller works is provided.

**Section 2** provides a description of all the components of the C200H. The names of all the individual parts of each Unit are given.

**Section 3** explains how to assemble the C200H. A detailed description of how to mount each Unit is provided.

**Section 4** outlines the system connections involved in installing a C200H Programmable Controller System. All I/O, including Remote I/O, are included.

**Section 5** contains the requirements for the installation environment of the C200H. Suggestions for preventing electrical noise are included.

**Section 6** explains the power considerations involved in installing the C200H.

**Section 7** lists safety considerations that should be kept in mind while installing the C200H.

**Appendixes**, a **Glossary**, and an **Index** are also provided.



### **WARNING**

Failure to read and understand the information provided in this manual may result in personal injury or death, damage to the product, or product failure. Please read each section in its entirety and be sure you understand the information provided in the section and related sections before attempting any of the procedures or operations given.



# PRECAUTIONS

This section provides general precautions for using the Programmable Controller (PC) and related devices.

**The information contained in this section is important for the safe and reliable application of the Programmable Controller. You must read this section and understand the information contained before attempting to set up or operate a PC system.**

1 Intended Audience .....	
2 General Precautions .....	
3 Safety Precautions .....	
4 Operating Environment Precautions .....	
5 Application Precautions .....	

## 1 Intended Audience

This manual is intended for the following personnel, who must also have knowledge of electrical systems (an electrical engineer or the equivalent).

- Personnel in charge of installing FA systems.
- Personnel in charge of designing FA systems.
- Personnel in charge of managing FA systems and facilities.

## 2 General Precautions

The user must operate the product according to the performance specifications described in the operation manuals.

Before using the product under conditions which are not described in the manual or applying the product to nuclear control systems, railroad systems, aviation systems, vehicles, combustion systems, medical equipment, amusement machines, safety equipment, and other systems, machines, and equipment that may have a serious influence on lives and property if used improperly, consult your OMRON representative.

Make sure that the ratings and performance characteristics of the product are sufficient for the systems, machines, and equipment, and be sure to provide the systems, machines, and equipment with double safety mechanisms.

This manual provides information for programming and operating the Unit. Be sure to read this manual before attempting to use the Unit and keep this manual close at hand for reference during operation.

 **WARNING** It is extremely important that a PC and all PC Units be used for the specified purpose and under the specified conditions, especially in applications that can directly or indirectly affect human life. You must consult with your OMRON representative before applying a PC System to the above-mentioned applications.

## 3 Safety Precautions



 **WARNING** Do not attempt to take any Unit apart while the power is being supplied. Doing so may result in electric shock.

 **WARNING** Do not touch any of the terminals or terminal blocks while the power is being supplied. Doing so may result in electric shock.

 **WARNING** Do not attempt to disassemble, repair, or modify any Units. Any attempt to do so may result in malfunction, fire, or electric shock.



 **Caution** Tighten the screws on the terminal block of the AC Power Supply Unit to the torque specified in this manual. The loose screws may result in burning or malfunction.

## 4 Operating Environment Precautions

-  **Caution** Do not operate the control system in the following places:
- Locations subject to direct sunlight.
  - Locations subject to temperatures or humidity outside the range specified in the specifications.
  - Locations subject to condensation as the result of severe changes in temperature.
  - Locations subject to corrosive or flammable gases.
  - Locations subject to dust (especially iron dust) or salts.
  - Locations subject to exposure to water, oil, or chemicals.
  - Locations subject to shock or vibration.
-  **Caution** Take appropriate and sufficient countermeasures when installing systems in the following locations:
- Locations subject to static electricity or other forms of noise.
  - Locations subject to strong electromagnetic fields.
  - Locations subject to possible exposure to radioactivity.
  - Locations close to power supplies.
-  **Caution** The operating environment of the PC System can have a large effect on the longevity and reliability of the system. Improper operating environments can lead to malfunction, failure, and other unforeseeable problems with the PC System. Be sure that the operating environment is within the specified conditions at installation and remains within the specified conditions during the life of the system.

## 5 Application Precautions

Observe the following precautions when using the PC System.

-  **WARNING** Always heed these precautions. Failure to abide by the following precautions could lead to serious or possibly fatal injury.
- Always ground the system to 100  $\Omega$  or less when installing the Units. Not connecting to a ground of 100  $\Omega$  or less may result in electric shock.
  - Always turn OFF the power supply to the PC before attempting any of the following. Not turning OFF the power supply may result in malfunction or electric shock.
    - Mounting or dismounting Power Supply Units, I/O Units, CPU Units, Memory Cassettes, or any other Units.
    - Assembling the Units.
    - Setting DIP switches or rotary switches.
    - Connecting or wiring the cables.
    - Connecting or disconnecting the connectors.
-  **Caution** Failure to abide by the following precautions could lead to faulty operation of the PC or the system, or could damage the PC or PC Units. Always heed these precautions.
- Fail-safe measures must be taken by the customer to ensure safety in the event of incorrect, missing, or abnormal signals caused by broken signal lines, momentary power interruptions, or other causes.

- Interlock circuits, limit circuits, and similar safety measures in external circuits (i.e., not in the Programmable Controller) must be provided by the customer.
- Always use the power supply voltage specified in the operation manuals. An incorrect voltage may result in malfunction or burning.
- Take appropriate measures to ensure that the specified power with the rated voltage and frequency is supplied. Be particularly careful in places where the power supply is unstable. An incorrect power supply may result in malfunction.
- Install external breakers and take other safety measures against short-circuiting in external wiring. Insufficient safety measures against short-circuiting may result in burning.
- Do not apply voltages to the Input Units in excess of the rated input voltage. Excess voltages may result in burning.
- Do not apply voltages or connect loads to the Output Units in excess of the maximum switching capacity. Excess voltage or loads may result in burning.
- Disconnect the functional ground terminal when performing withstand voltage tests. Not disconnecting the functional ground terminal may result in burning.
- Install the Unit properly as specified in the operation manual. Improper installation of the Unit may result in malfunction.
- Be sure that all the mounting screws, terminal screws, and cable connector screws are tightened to the torque specified in the relevant manuals. Incorrect tightening torque may result in malfunction.
- Leave the label attached to the Unit when wiring. Removing the label may result in malfunction.
- Remove the label after the completion of wiring to ensure proper heat dissipation. Leaving the label attached may result in malfunction.
- Use crimp terminals for wiring. Do not connect bare stranded wires directly to terminals. Connection of bare stranded wires may result in burning.
- Double-check all the wiring before turning ON the power supply. Incorrect wiring may result in burning.
- Mount the Unit only after checking the terminal block completely.
- Be sure that the terminal blocks, Memory Units, expansion cables, and other items with locking devices are properly locked into place. Improper locking may result in malfunction.
- Check the user program for proper execution before actually running it on the Unit. Not checking the program may result in an unexpected operation.
- Confirm that no adverse effect will occur in the system before attempting any of the following. Not doing so may result in an unexpected operation.
  - Changing the operating mode of the PC.
  - Force-setting/force-resetting any bit in memory.
  - Changing the present value of any word or any set value in memory.
- Do not pull on the cables or bend the cables beyond their natural limit. Doing either of these may break the cables.
- Do not place objects on top of the cables. Doing so may break the cables.

# SECTION 1

## Introduction

This section provides general information about Programmable Controllers (PCs) and how they fit into a Control System.

- 1-1 What is a Control System? .....
- 1-2 The Role of the PC .....
- 1-2-1 Input Devices .....
- 1-2-2 Output Devices .....
- 1-3 How Does a PC Work? .....

### 1-1 What is a Control System?

A Control System is the electronic equipment needed to control a particular process. It may include everything from a process control computer, if one is used, to the factory computer, down through the PCs (and there may be many of them networked together) and then on down through the network to the control components: the switches, stepping motors, solenoids, and sensors which monitor and control the mechanical operations.

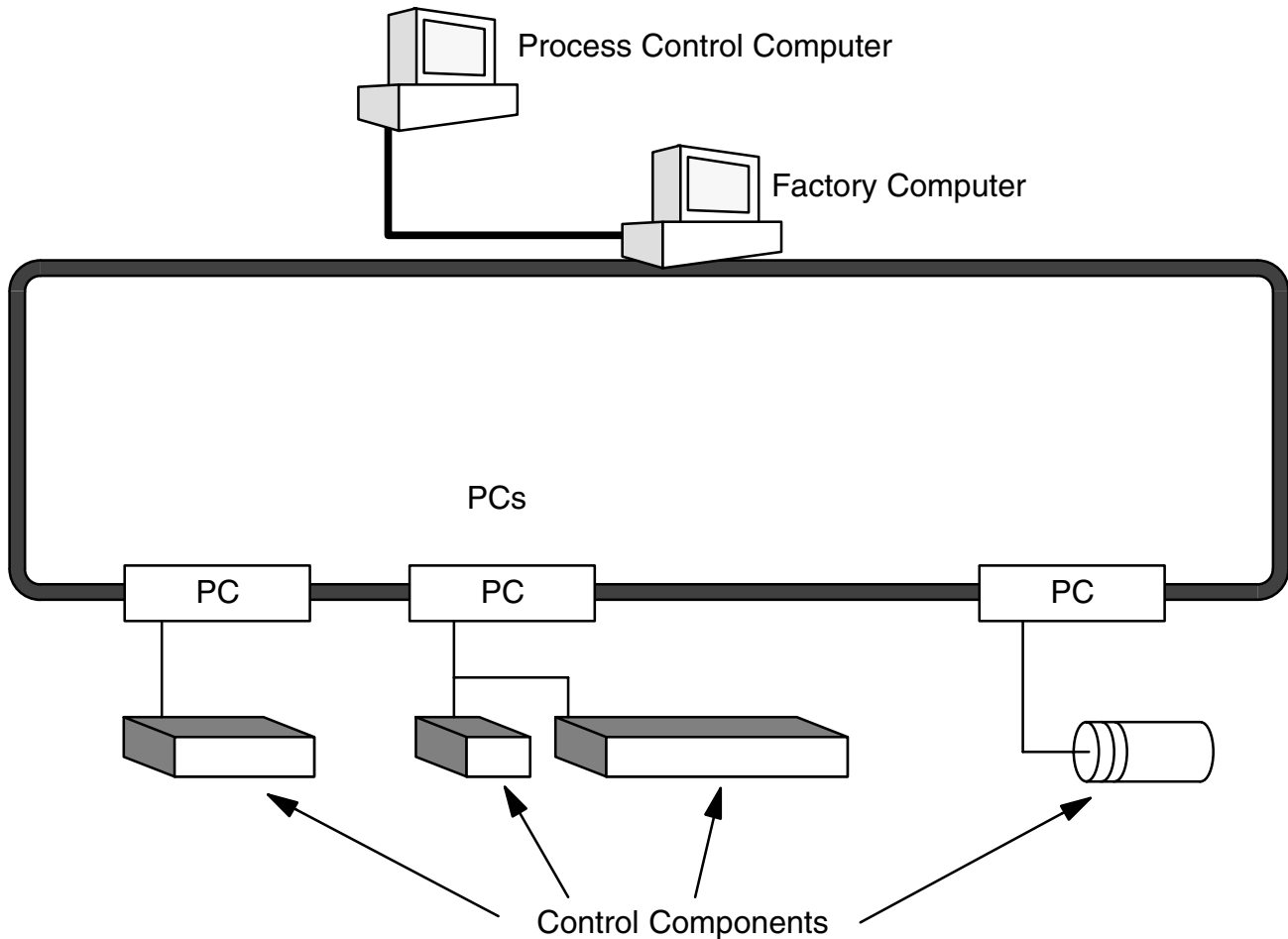

A Control System can involve very large applications where many different models of PC are networked together or it could be an application as small as a single PC controlling a single output device.



A Position Control System

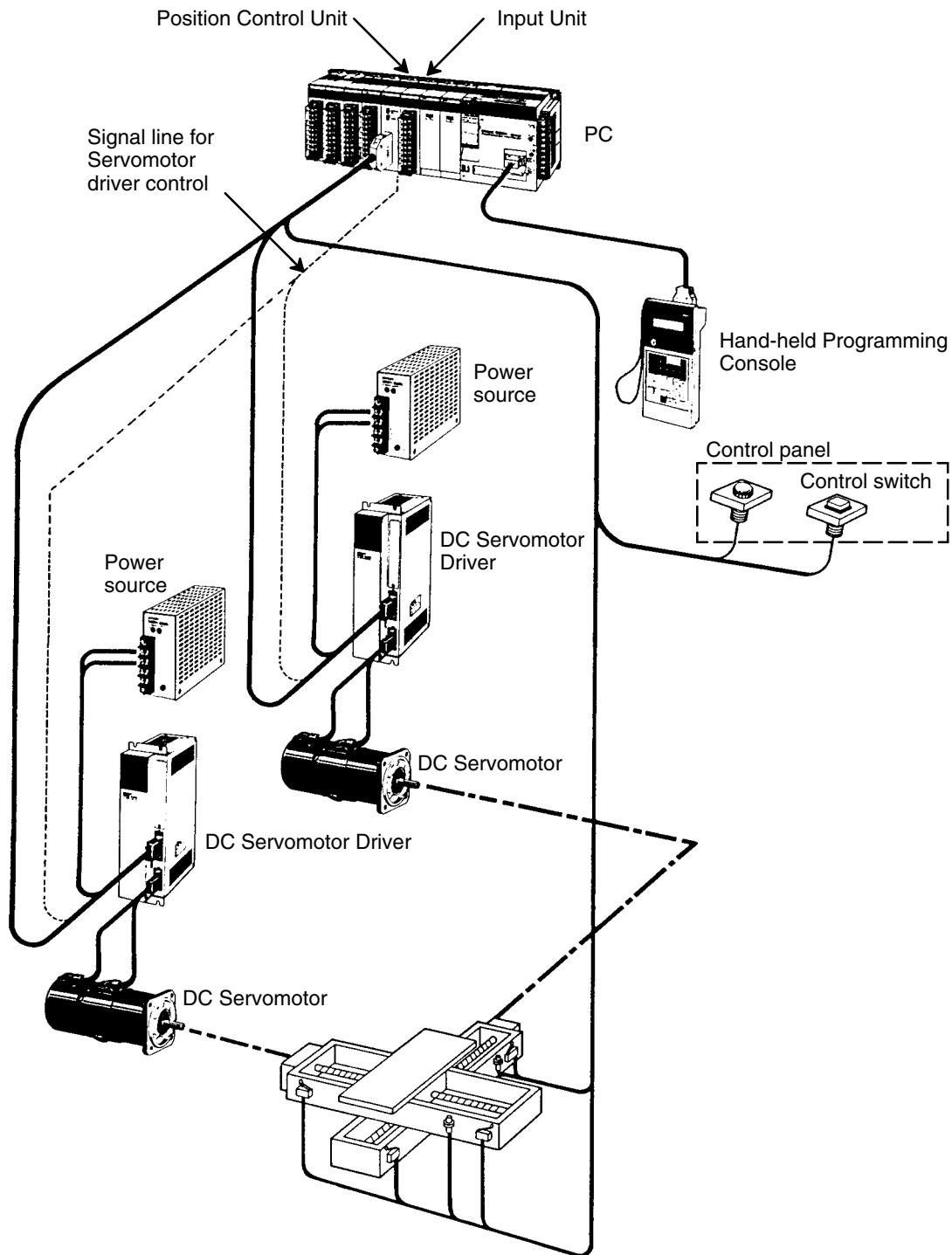

In the typical Control System example shown above, a PC controls the movement of the workpiece bed across two horizontal axes using Limit Switches and Servomotors to monitor and control movement.

## 1-2 The Role of the PC

The PC is the part of the Control System that directly controls the manufacturing process. According to the program stored in its memory, the PC accepts data from the input devices connected to it, and uses this data to monitor the controlled system. When the program calls for some action to take place, the PC sends data to the output devices connected to it, to cause that action to take place. The PC may be used to control a simple, repetitive task, or it may be connected to other PCs, or to a host computer in order to integrate the control of a complex process.

### 1-2-1 Input Devices

PCs can receive input from either automated or manual devices. The PC could receive data from the user via a pushbutton switch, keyboard, or similar device. Automated input could come from a variety of devices: microswitches, timers, encoders, photosensors, and so on. Some devices, like the Limit Switch shown below, turn ON or OFF when the equipment actually makes contact with it. Other devices, like the Photoelectric Switch and Proximity Switch shown below, use other means, such as light or inductance, in order to get information about the equipment being monitored.

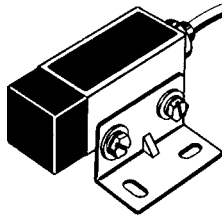

Photoelectric Switch

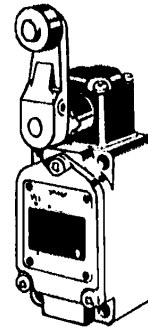

Limit Switch

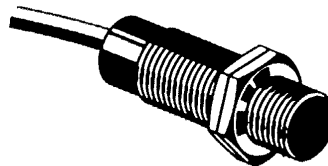

Proximity Switch

### 1-2-2 Output Devices

A PC can output to a myriad of devices for use in automated control. Almost anything that you can think of could be controlled (perhaps indirectly) by a PC. Some of the most common devices are motors, Solenoids, Servomotors, Stepping Motors, valves, switches, indicator lights, buzzers, and alarms. Some of these output devices; such as the motors, Solenoids, Servomotors, Stepping Motors, and valves; affect the controlled system directly. Others; such as the indicator lights, buzzers, and alarms; provide output to notify personnel.

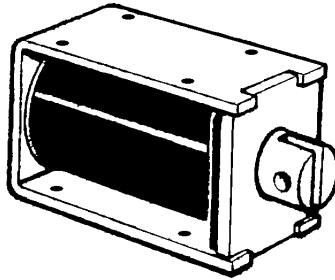

Solenoid

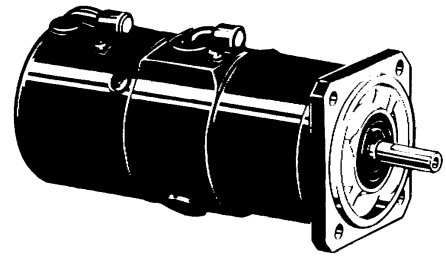

Servomotor

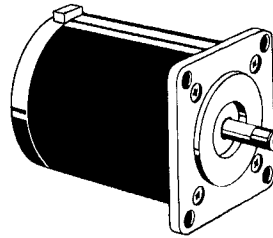

Stepping Motor

## 1-3 How Does a PC Work?

PCs operate by monitoring input signals and providing output signals. When changes are detected in the signals, the PC reacts, through the user-programmed internal logic, to produce output signals. The PC continually cycles the program in its memory to achieve this control.

### Block Diagram of PC

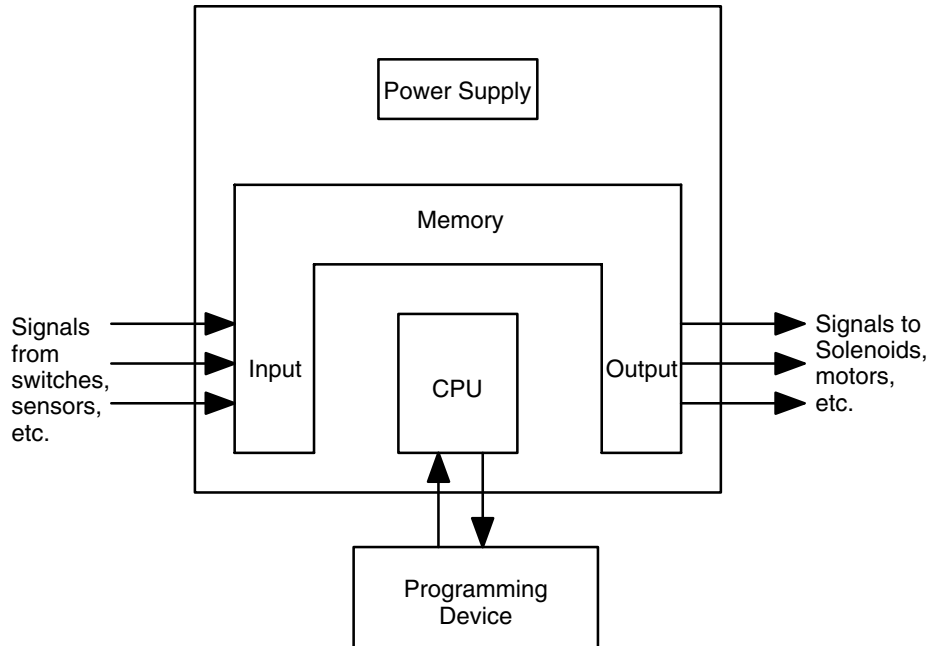

A program for your applications must be designed, and stored in the PC. This program is then executed as part of the cycle of internal operations of the PC.

### Cycle

When a PC operates, that is, when it executes its program to control an external system, a series of operations are performed inside the PC. These internal operations can be broadly classified into the following four categories:

- 1, 2, 3...** 1. Common (or overseeing) processes, such as watchdog timer operation and testing the program memory.
2. Data input and output.
3. Instruction execution.
4. Peripheral device servicing.

### Cycle Time

The total time required for a PC to perform all these internal operations is called the cycle time. The flowchart and diagram on the following page illustrate these internal operations for a typical PC.

Timing is one of the most important factors in designing a Control System. For accurate operations, it is necessary to have answers to such questions as these:

- How long does it take for the PC to execute all the instructions in its memory?
- How long does it take for the PC to produce a control output in response to a given input signal?

The cycle time of the PC can be automatically calculated and monitored, but it is necessary to have an understanding of the timing relationships within the PC for effective System design and programming.

PC Operation Flowchart

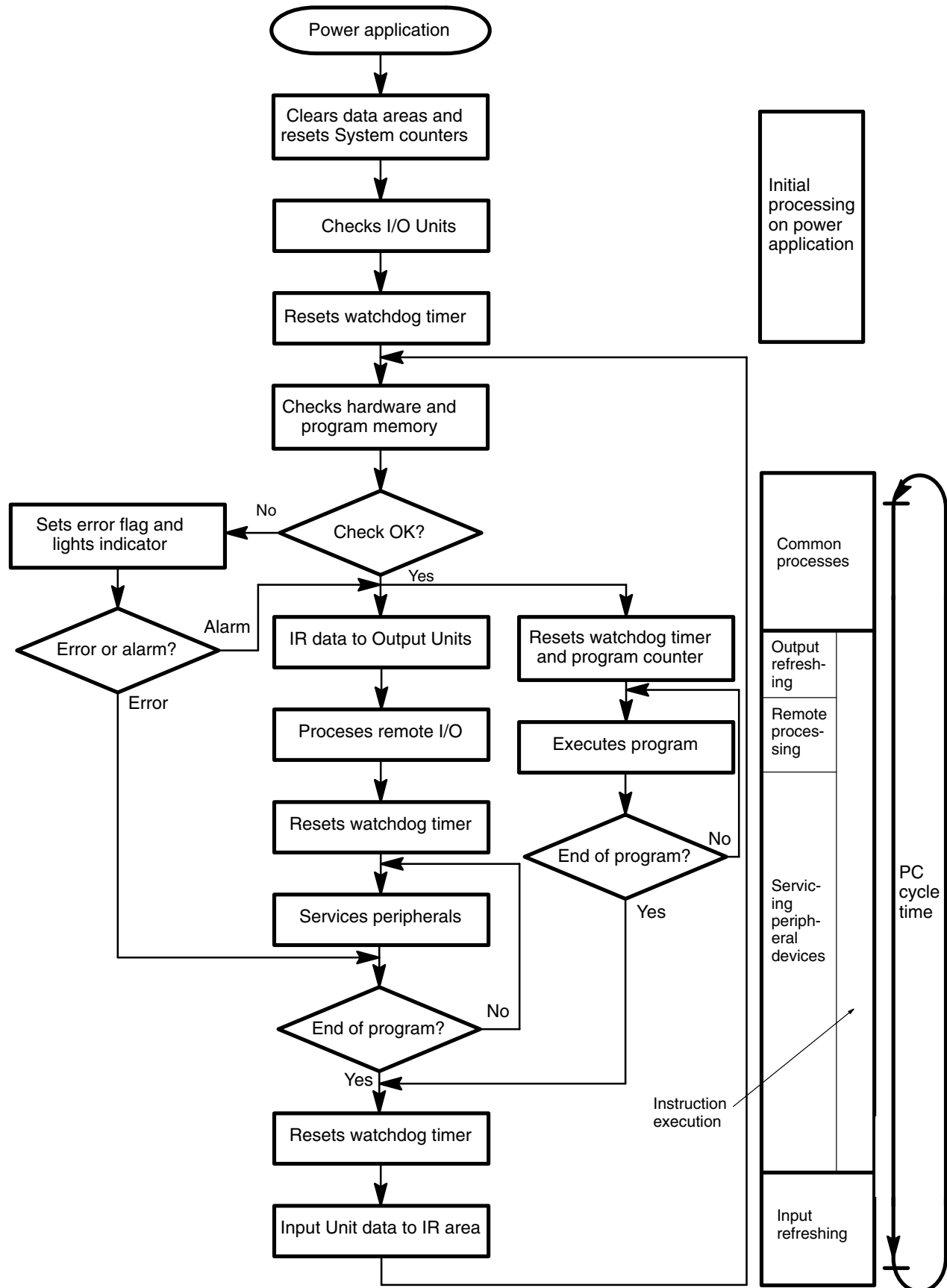



## SECTION 2

### Description

This section provides information about the individual Units that make up a PC. The names of all the parts of a Unit are given, followed by any details that apply to that Unit alone. For a description of how the Units fit together to become a PC, refer to *Section 3 Assembly Instructions*. For information about the model numbers of any of the parts described in this section, refer to *Appendix C Standard Models*.

2-1	CPU Rack .....
2-2	CPU .....
2-3	Expansion I/O Rack .....
2-4	Power Supply .....
2-5	I/O Units .....
2-6	Memory Units .....

## 2-1 CPU Rack

The following figure shows the names of all the parts of a CPU Rack. There are four models of Backplanes available with 3, 5, 8 and 10 slots for I/O Units. You can use any of these Backplanes to build a CPU or Expansion I/O Rack. However, the C200H-OC225/OD212/OD21A 16-point Output Unit and C200H-B7A01 B7A Interface Unit must be mounted to a C200H-BC□□1-V1/V2 Backplane.

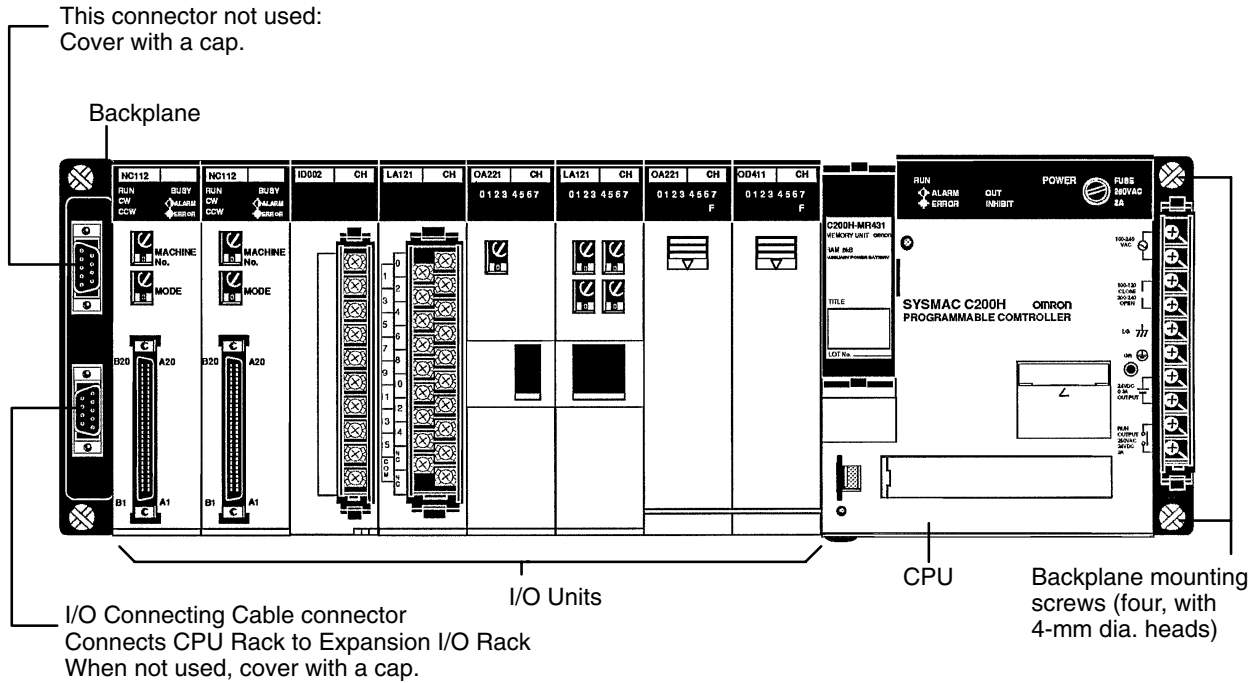



## 2-2 CPU

The CPU is available in three models. The C200H-CPU01-E and C200H-CPU11-E both run on 100 to 120 or 200 to 240 VAC, and the C200H-CPU03-E runs on 24 VDC. The C200H-CPU11-E is unique in that it connects the SYSMAC LINK Unit or SYSMAC NET Link Unit to the CPU. These two Units are mounted to either of the two slots located directly to the left of the CPU and connected to the CPU via a bus connector. A separate Unit, the Bus Connector Unit, is required to connect the SYSMAC NET Link Unit or the SYSMAC LINK Unit to the CPU.

Also note that model C200H-CPU11-E has an additional battery connected to the CPU.

**Note** If you are using the SYSMAC LINK Unit or SYSMAC NET Link Unit in your C200H system, use model C200H-CPU11-E as the CPU. Otherwise, the link Units cannot be used.

### C200H-CPU01-E/03

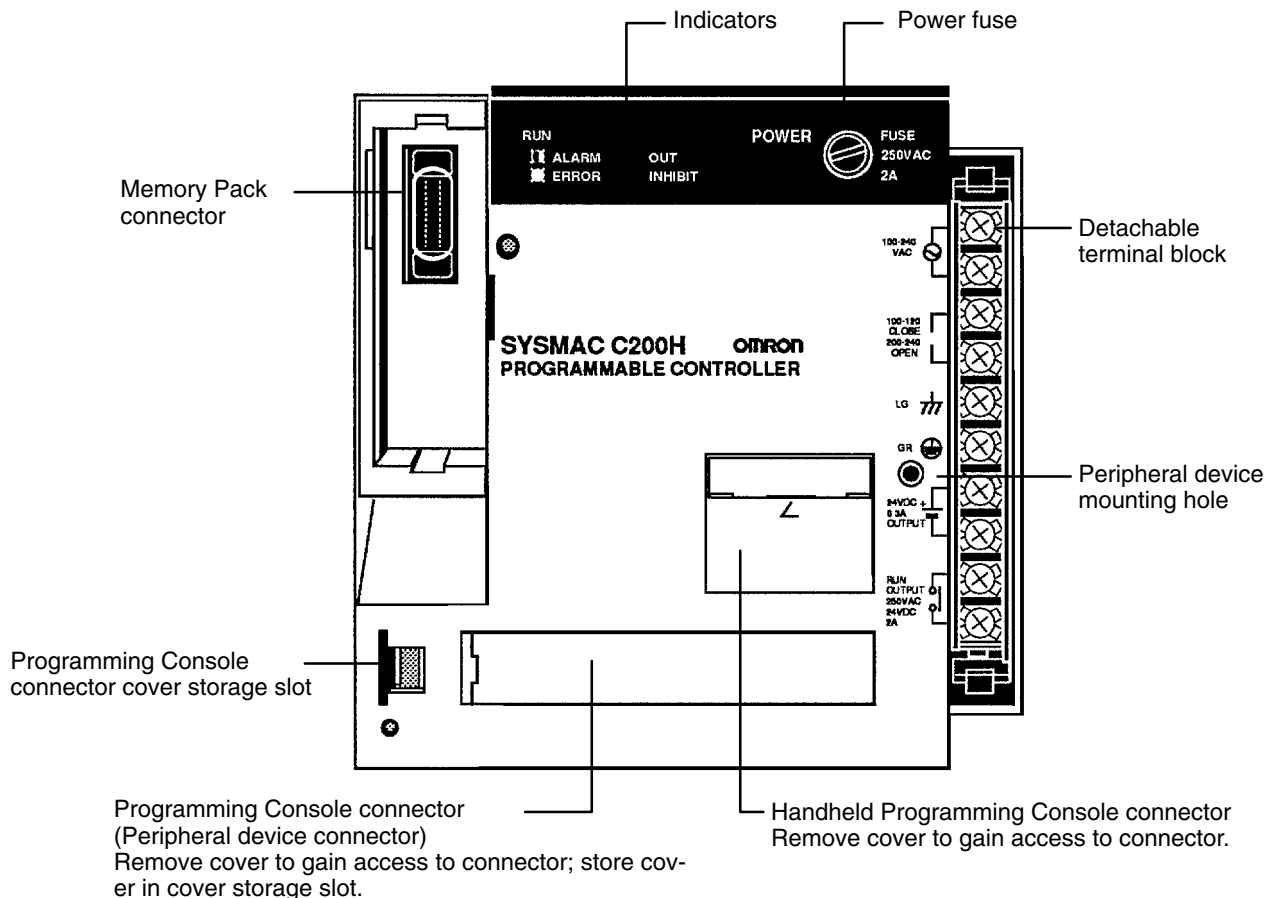

C200H-CPU11-E

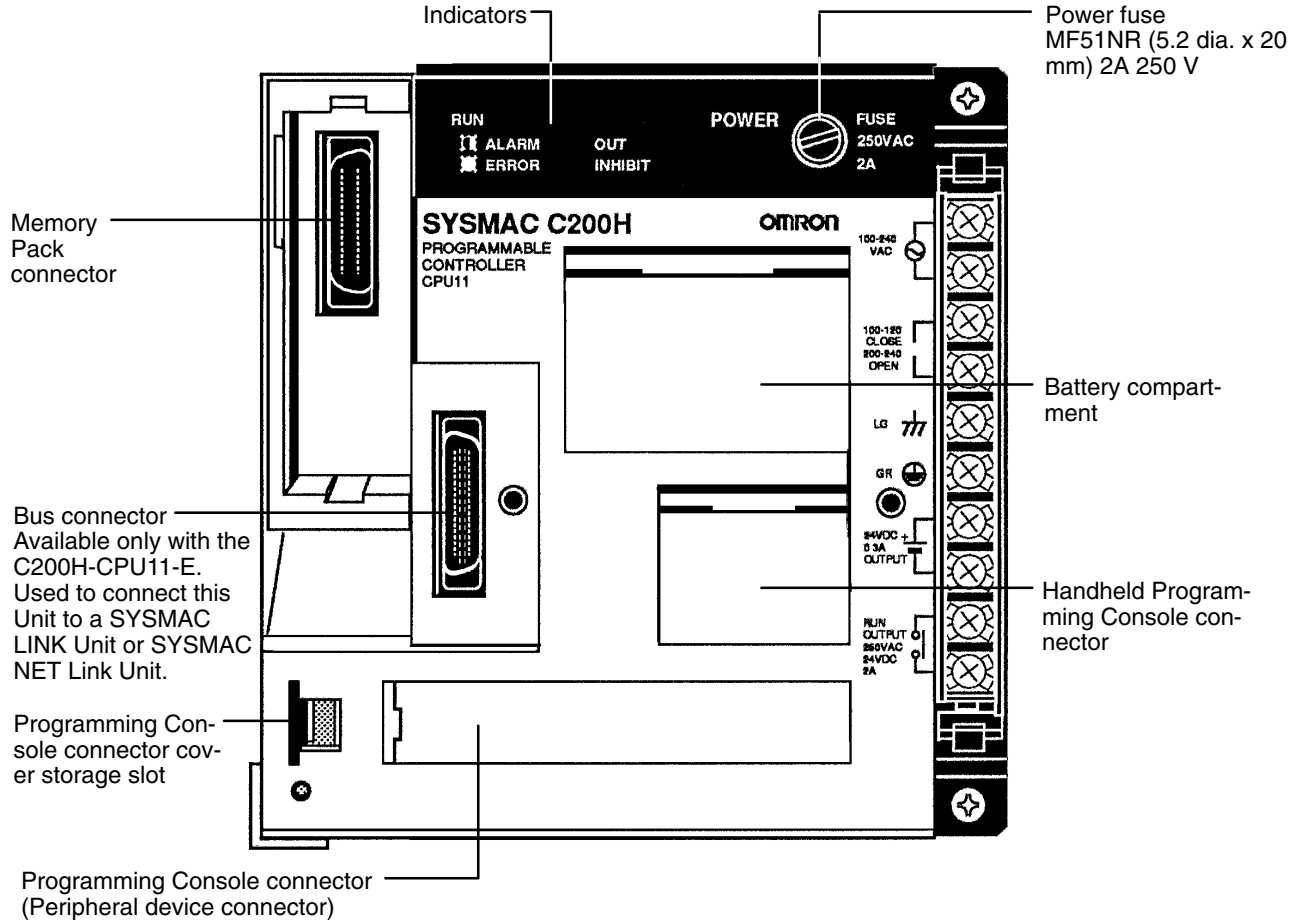

CPU Indicators

The following figure shows the indicators that are located on the front panel of the three CPU models.

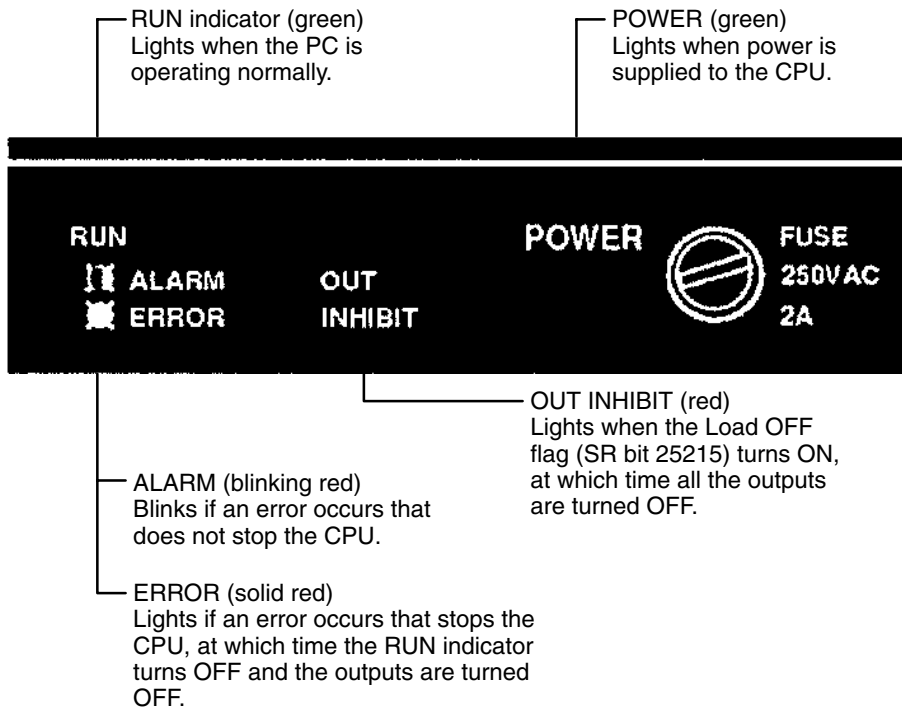

## Peripheral Device Connectors

All three CPU models are equipped with two connectors for peripheral devices. One is used for the Handheld Programming Console or the Data Access Console; the other is used for the CPU-Mounting Programming Console. The C200H-CPU11-E, however, has a third connector that is used for connecting the SYSMAC LINK Unit or the SYSMAC NET Link Unit to the CPU.

To connect the Handheld Programming Console to the CPU, a Connecting Cable is required, as shown in the following diagram.

**Note** If you are using the SYSMAC LINK Unit or SYSMAC NET Link Unit in your system, you must use model C200H-CPU11-E as the CPU. The other two models mentioned above are not equipped with the appropriate connectors.

## Cable Connection

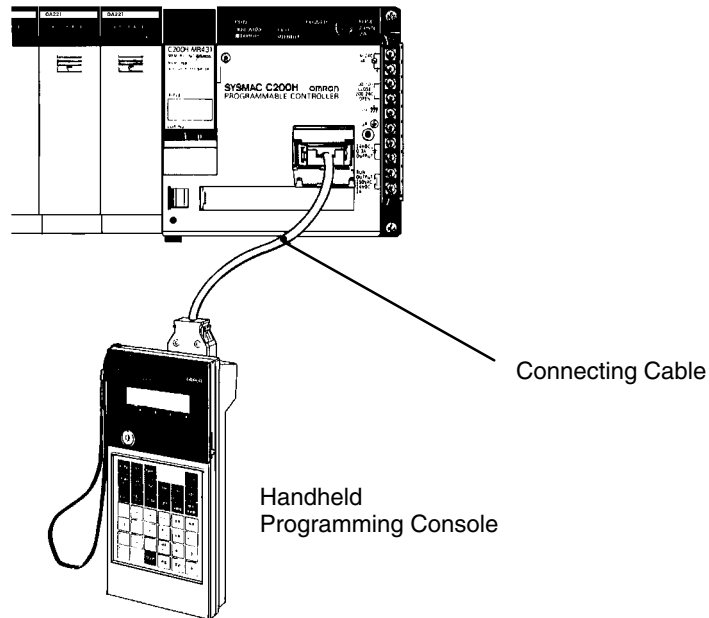

The CPU-mounting Programming Console can be mounted directly to the CPU and does not require a Connecting Cable. To mount the CPU-Mounting Programming Console (or any other peripheral device) directly to the CPU, follow the steps below.

## Direct Mounting

The CPU-mounting Programming Console, when mounted to the CPU, covers the two I/O Units located directly to the left of the CPU. For this reason it is important to know which shapes can be mounted to these slots.

Notice, in the following diagram, that the two I/O Units mounted directly to the left of the CPU are A-shape Units. The CPU-mounting Programming Console can be mounted to the CPU provided A-shape I/O Units are mounted to these two slots. Make sure the protective covers of the two I/O Units are in place to avoid electrical interference with the CPU.

Because the surface of B-shape and E-shape I/O Units protrudes a few centimeters from surface of the CPU, B-shape and E-shape I/O Units cannot be mounted to the two slots to the left of the CPU unless a Programming Console Base Unit is first mounted to the CPU to increase the mounting height of the Programming Console.

If you are using the C200H-CPU11-E, a SYSMAC LINK Unit or a SYSMAC LINK Unit can be mounted to either of the two slots to the left of the CPU. They are then connected to the CPU with the Bus Connector Unit.

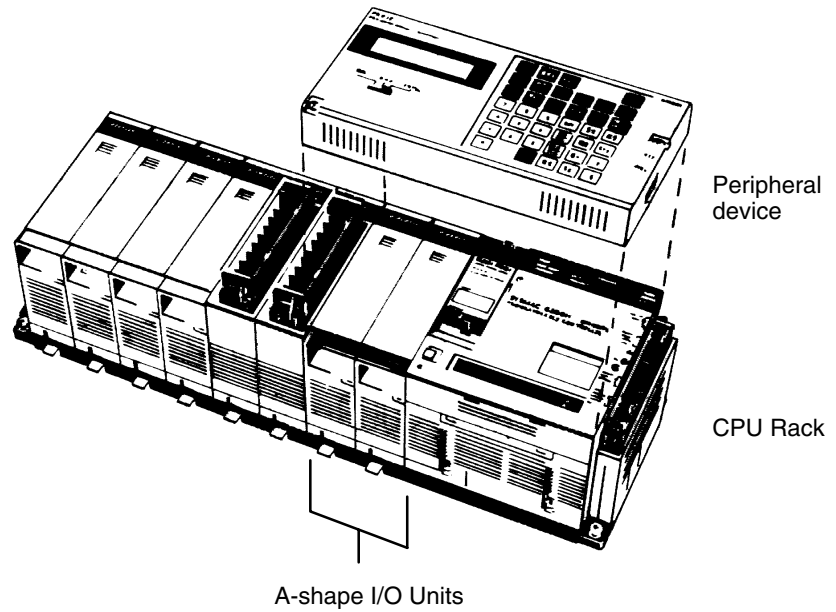

- 1, 2, 3...**
1. Remove the cover from the peripheral device connector with a standard screwdriver.
  2. Connect the CPU-Mounting Programming Console to the peripheral device connector.
  3. Attach the CPU-Mounting Programming Console to the CPU by tightening the mounting screws.

## 2-3 Expansion I/O Rack

The Backplane used to construct a CPU Rack is also used to construct an Expansion I/O Rack. An Expansion I/O Rack is identical to a CPU Rack, except the CPU has been replaced with a Power Supply. The parts of an Expansion I/O Rack are shown in the following diagram.

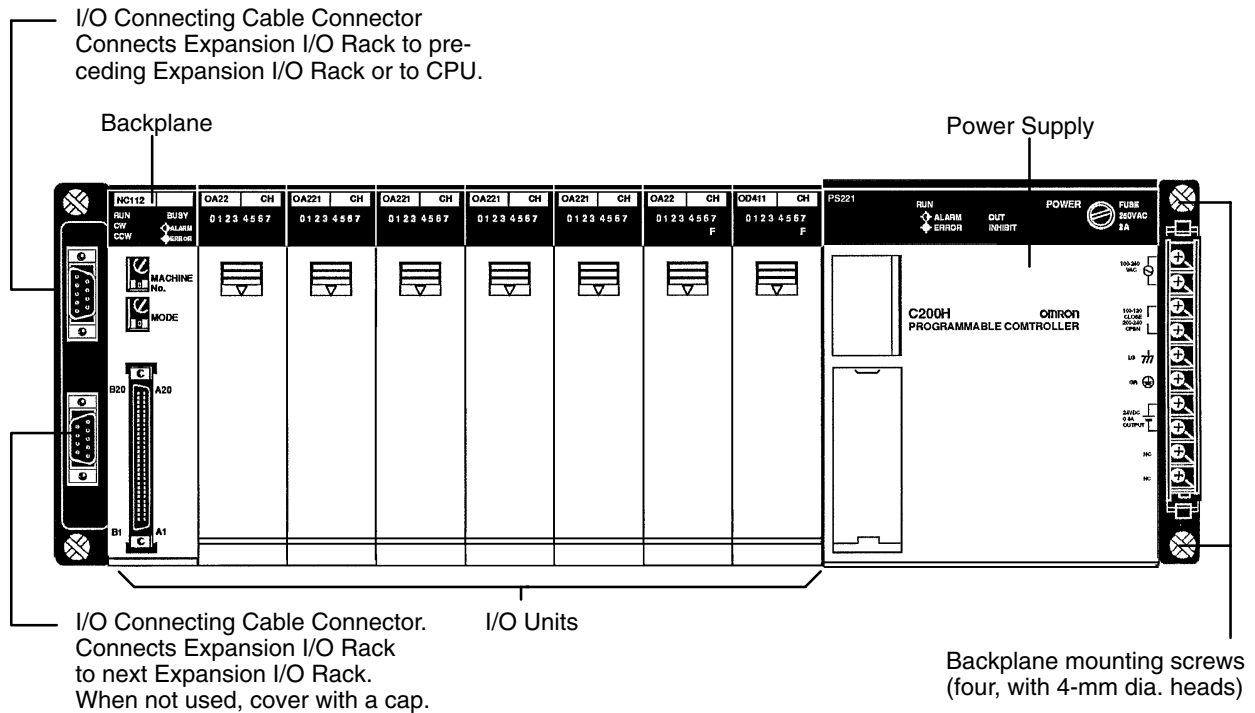

## 2-4 Power Supply

The Power Supply used for Expansion I/O Racks is available in two models. One runs on 100 to 120 or 200 to 240 VAC, and the other runs on 24 VDC.

### AC Power Supply

POWER indicator (green)  
Lights when power is supplied to Power Supply

Power fuse 2 A 250 V  
(5.2-dia. x 20) MF51NR

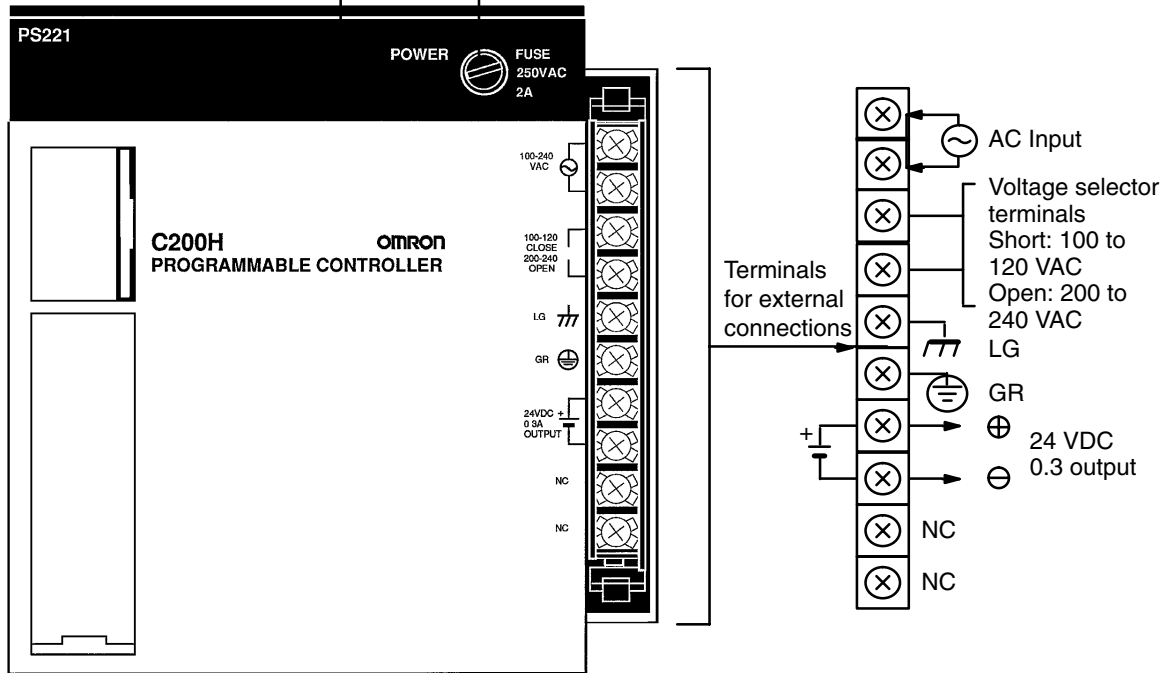

DC Power Supply

POWER indicator (green)  
Lights when power is supplied to Power Supply

Power fuse 5 A 125 V  
(5.2-dia. x 20)  
MF51NR

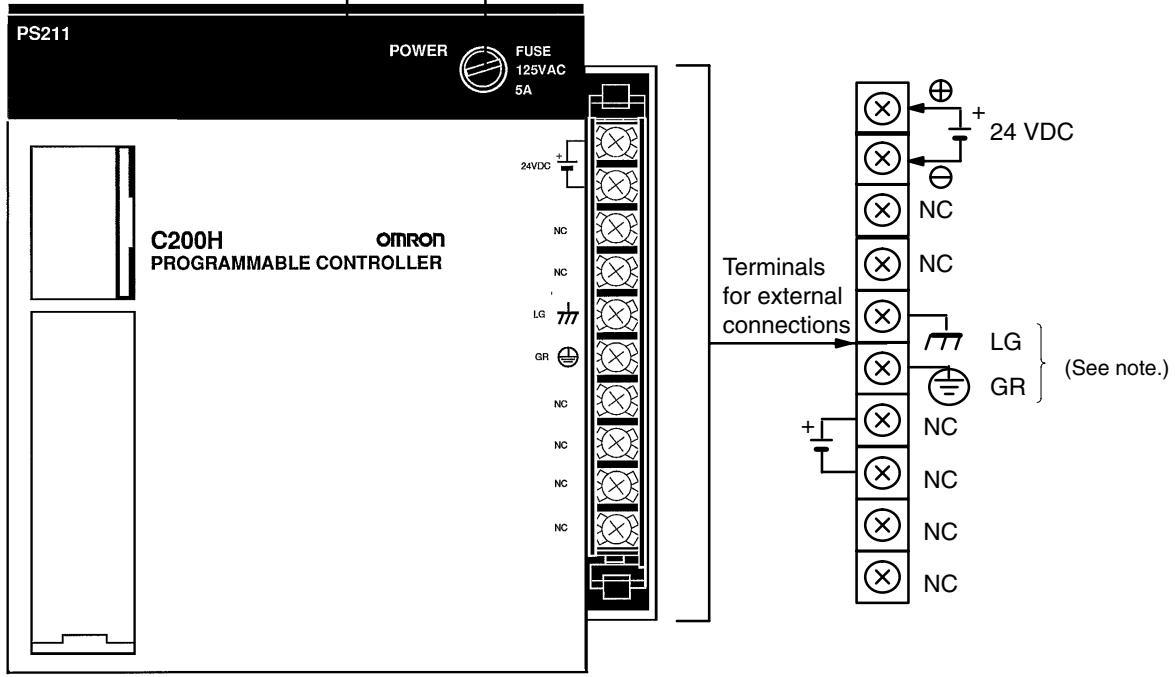

**Note** The LG and GR terminals are connected internally.

## 2-5 I/O Units

I/O Units come in three shapes: A-shape, B-shape, and E-shape. Refer to *Appendix B Specifications* for the dimensions of each Unit.

### A-shape I/O Units

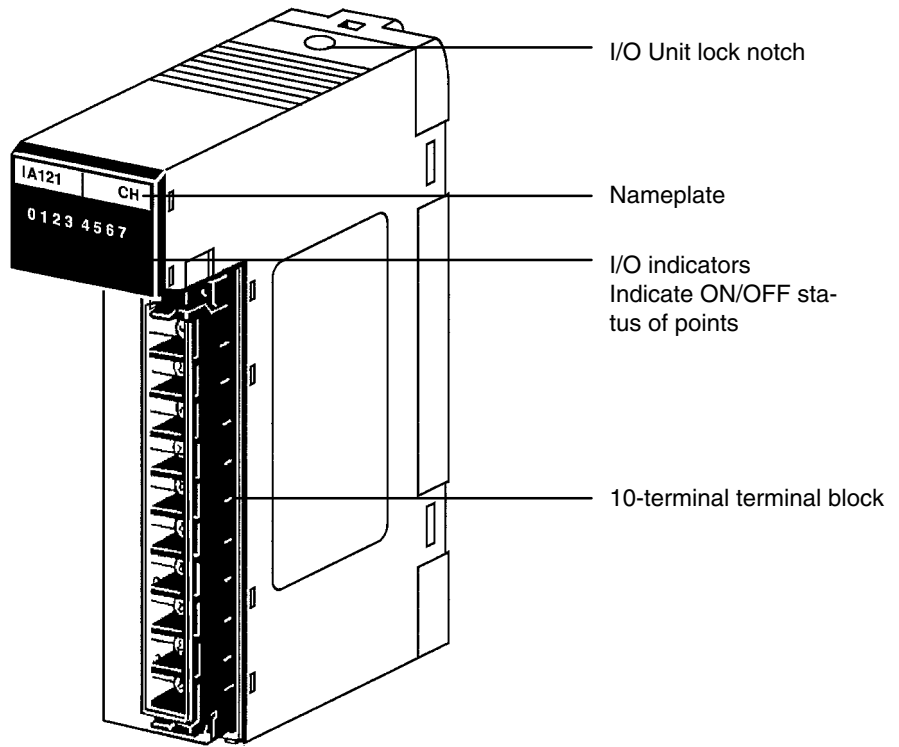

### B-shape I/O Units

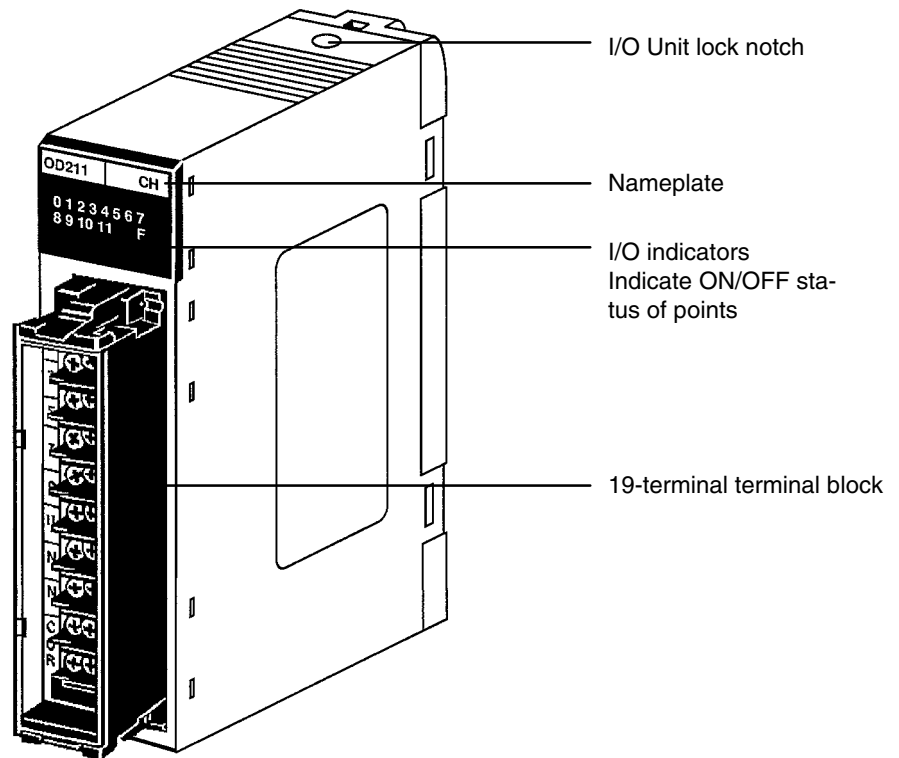



E-shape I/O Units

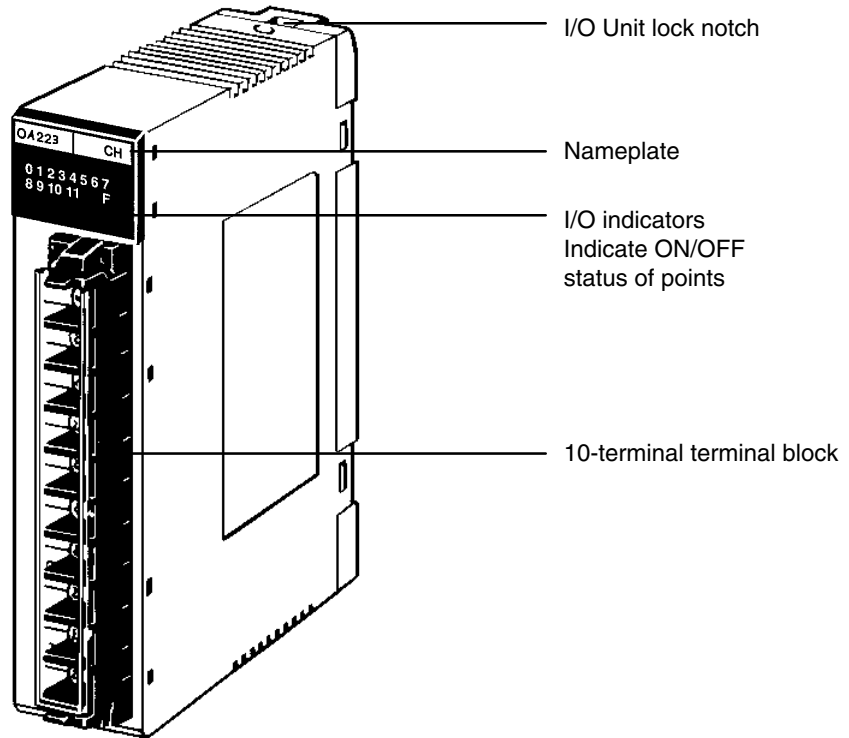

2-6 Memory Units

There are three types of Memory Units, having three different types of memory. The three types of memory are EPROM, EEPROM, and RAM.

Memory	Model	Capacity	Maximum program size	Backup	Clock <sup>1</sup>
EPROM	C200H-MP831	8K words	6,974 words	---	NO
EEPROM	C200H-ME431	4K words	2,878 words		
	C200H-ME831	8K words	6,974 words		
RAM	C200H-MR431	4K words	2,878 words	Battery	NO
	C200H-MR831	8K words	6,974 words		
	C200H-MR432	4K words	2,878 words	Capacitor	
	C200H-MR832	8K words	6,974 words		

Contents for Memory Unit Registration

Fixed DM area (DM 1000 to DM 1999)
I/O table (see note)
UM (ladder program area)

**Note** I/O tables are also saved in the Memory Unit at the time of creation. Therefore, if the Memory Unit is set to write-protect, it will be impossible to create an I/O table.

**EPROM Unit**

The data that you wish to store in an EPROM Unit must first be written to an EPROM Chip, using the PROM Writer. Then the EPROM Chip must be mounted to the inside of the EPROM Unit. Once this has been done, the data cannot be changed. In addition, the data will be retained indefinitely when the power is turned OFF.

**EEPROM Unit**

Data can be stored in the EEPROM Unit while the Unit is mounted to the PC. The data is retained indefinitely when the power is turned OFF.

**RAM Unit**

Data can be randomly written to and read from the RAM Unit. However, the Unit requires battery or capacitor back-up in order to retain the information when the power is OFF. Units with battery back-up can retain their data for approximately five years at room temperature (25°C). Units with capacitor back-up retain their data for approximately 20 days at room temperature, but the length of time varies with temperature as shown below.

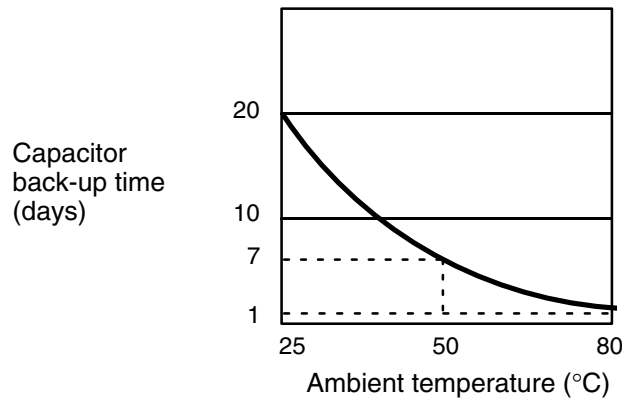

**Switches on Memory Units**

Two switches are provided on Memory Units, as shown below.

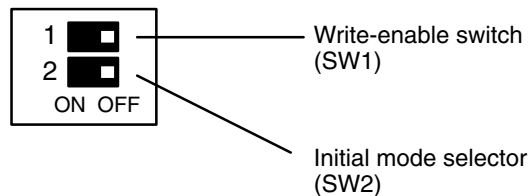

SW1 (the write enable switch) only has an effect if the Unit is a RAM Unit or EEPROM Unit. Peripheral devices can only write data to these Memory Units if SW1 is ON. When you wish to write data to this Memory Unit, make sure SW1 is set to the ON position. After you have finished writing the data to the Memory Unit, turn SW1 to the OFF position so that the data will be protected from any further changes. If you try to write data to the Memory Unit while SW1 is in the OFF position, the message “DISABLED ROM” will appear on the Programming Console.

SW2 Selects what operating mode the PC will be in when power is applied to the System. If there is no peripheral device connected to the CPU, the PC will enter RUN mode when power is applied. If a Programming Console is connected to the CPU, the PC will enter the mode that the Programming Console is set to. If a peripheral device other than the Programming Console is connected to the CPU, the PC will enter the mode specified by SW2.

**Battery Failure Flag**

The C200H-CPU11-E, unlike the other two CPU models, has an additional battery connected to the CPU. A flag, assigned to the bits listed in the following table, indicates where battery failure occurred (in the RAM Unit or in the CPU) and in which Unit.

Model	Bit	Function
C200H-CPU01-E/03	25308	Battery failure in RAM Unit
C200H-CPU11-E	25308	Battery failure in RAM Unit or CPU
	AR2404	Battery failure in CPU

In the following table, the ON/OFF status of the bits indicate where battery failure took place in the C200H-CPU11-E. For example, when bit 25308 is ON the battery in the CPU failed.

25308	AR2404	Unit in which the battery failed
ON	ON	CPU
ON	OFF	RAM Unit



# SECTION 3

## Assembly Instructions

When we speak of a PC, we usually think of it as a single object. But actually even the simplest PCs are usually composed of several different devices. In fact a single PC can be physically spread throughout a building, but we still call it one PC.

- 3-1 Mounting the Units .....
- 3-2 Memory Packs .....
- 3-3 System Configurations .....

## 3-1 Mounting the Units

There is no single Unit that can be said to constitute a Rack PC. To build a Rack PC, we start with a Backplane. The Backplane for the C200H is shown below.



C200H Backplane

The Backplane is a simple device having two functions. The first is to provide physical support for the Units to be mounted to it. The second is to provide the connectors and electrical pathways necessary for connecting the Units mounted to it.

The core of the PC is the CPU. The CPU contains the program consisting of the series of steps necessary for the control task. The CPU has a built-in power supply, and fits into the rightmost position of the Backplane.



The CPU of the C200H has no I/O points built in. So, in order to complete the PC we need to mount one or more I/O Units to the Backplane. Mount the I/O Unit to the Backplane by locking the top of the I/O Unit into the slot on the Backplane and rotating the I/O Unit downwards as shown in the following diagram. Press down on the yellow tab at the bottom of the slot, press the I/O Unit firmly into position, and then release the yellow tab.

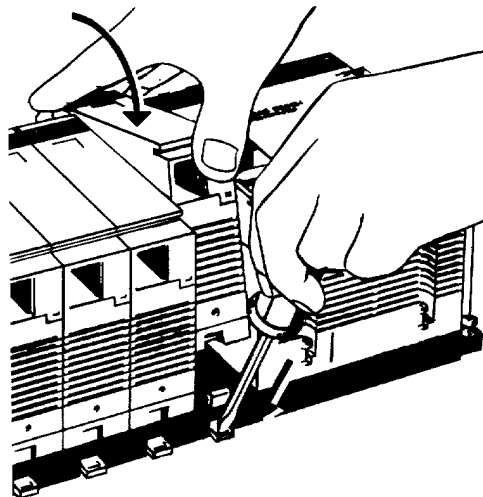

The figure below shows one I/O Unit mounted directly to the left of the CPU.



I/O Units are where the control connections are made from the PC to all the various input devices and output devices. As you can see from the figure above, there is still some space available on the left side of the Backplane. This space is for any additional I/O Units that may be required.

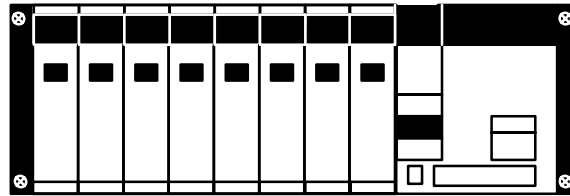

The figure above shows a total of eight I/O Units mounted to the Backplane. I/O Units come in three shapes; A-shape, B-shape, and E-shape (refer to *Appendix B Specifications* for dimensions). Normally, only A-shape I/O Units can be mounted to the two rightmost I/O Unit positions on the Backplane (the ones next to the CPU). This is so that there will be enough room to mount peripheral devices such as a Programming Console to the CPU. However, if you use a Programming Console Base Unit to increase the mounting height of the Programming Console, you will be able to mount the Programming Console to the CPU even if there are B-shape and/or E-shape I/O Units mounted to the two rightmost slots.

The C200H-OC225/OD212/OD21A 16-point Output Unit and C200H-B7AO1 B7A Interface Unit can be mounted only to a C200H-BC□□1-V1/V2 Backplane. If a Backplane other than these two models is used, the Units will not operate properly.

Backplanes are available in different lengths (three, five, eight, ten slots), and can hold a different number of I/O Units accordingly (refer to *Appendix B Specifications* for dimensions). Of course, not all I/O Units look exactly alike, but the ones in the figure show their typical appearance. This configuration of Backplane, CPU, and I/O Units is called a CPU Rack. This term refers to the Backplane and all the Units mounted to it. However, if we want to include more than eight I/O Units in our configuration we can add an additional Backplane.

This Backplane has I/O Units mounted to it, but it has no CPU of its own. The additional Backplane must also have an Expansion I/O Power Supply mounted to its rightmost position. This configuration of additional Backplane, Expansion I/O Power Supply, and I/O Units is called an Expansion I/O Rack.

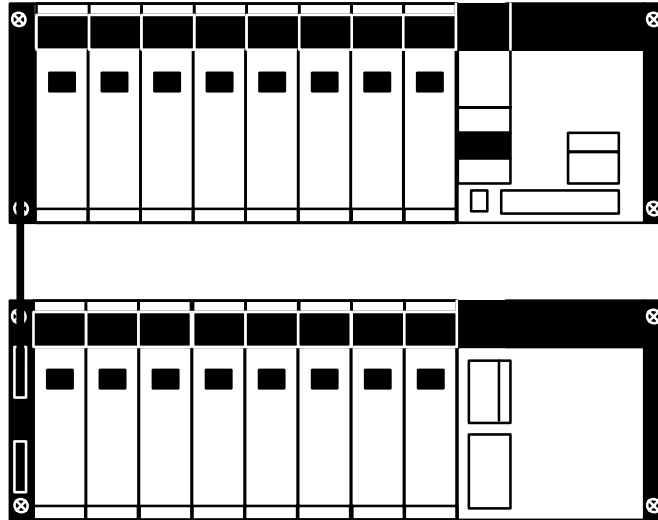

The CPU Rack and Expansion I/O Rack shown above are connected by a Connecting Cable (the length of Cable between individual Racks can be up to 10 m, but the total length of Cable between all Racks must be within 12 m).

Remember that this whole configuration is still referred to as one PC. It is possible to add up to two Expansion I/O Racks to one CPU Rack. When installing I/O Connecting Cables, cover any unused connectors with the caps provided.



## 3-2 Memory Packs

The CPU has a removable Memory Pack that stores the user program. Memory Packs are available with three types of memory; EPROM, EEPROM, and RAM (refer to *Section 2-6 Memory Packs*). If this is your first C200H, then you must have a RAM Pack in order to write and test the program you are going to use. If this is not your first C200H and you have a complete, tested program already, you can copy the program to an EPROM or EEPROM Pack for use on this C200H. The EEPROM chip can be written to without removing the chip from the Memory Pack by using an appropriate peripheral device (refer to *Appendix C Standard Models*). The EPROM Chip may be programmed using a PROM Writer or a FIT Ladder Pack. Then the EPROM Chip must be mounted inside the EPROM Pack.

**Note** Only PROM Writer Model C500-PRW06 may be used with the SYSMAC C200H.

### How to Mount an EPROM Chip to the Memory Pack

After the data has been written to the EPROM Chip, mount it to the inside of the EPROM Pack by following these steps.

- 1, 2, 3...** 1. Remove the cover of the EPROM Pack as shown below.

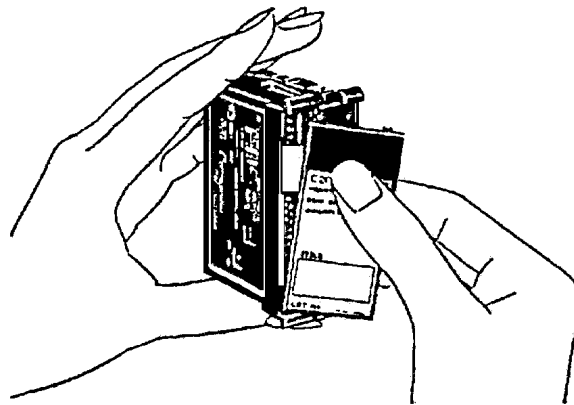

2. Unlock the holding bracket and slide it upward to remove it as shown below

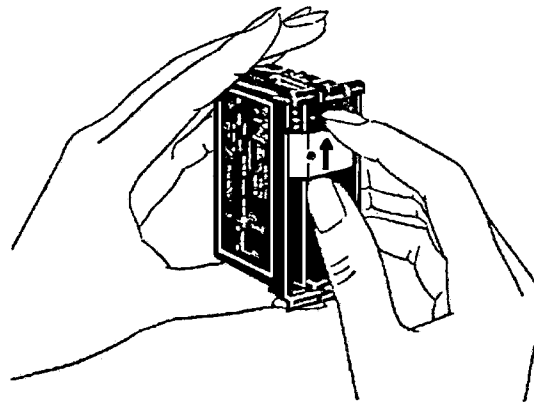

3. Pull the printed circuit board out of the EPROM Pack.

4. On the printed circuit board there is a socket for the EPROM Chip. On the socket you will find a notch. Align the notch on the socket with the notch on the EPROM Chip and mount the EPROM Chip to the socket as shown below.

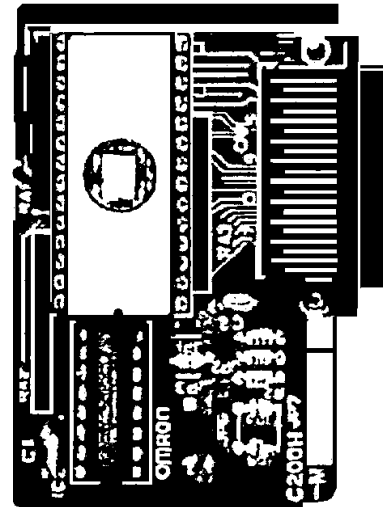

Notch

5. Reassemble the EPROM Pack in the reverse order of disassembly. During reassembly, ensure that the circuit board is inserted along the guides on the top and bottom of the Pack housing and that the projections on the housing fit into the holes in the holding bracket. Be sure to lock the holding bracket into the right side of the housing. When reassembled, the Pack should appear as shown below.

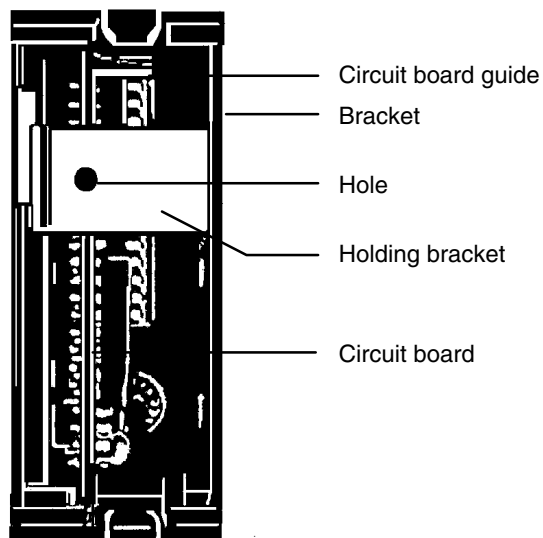

Circuit board guide

### How to Mount the Memory Pack to the CPU

Mount the Memory Pack to the CPU by following the steps below.

- 1, 2, 3... 1. Turn OFF the power to the PC.



#### Caution

Do not attempt to mount the Memory Pack to the CPU while the power to the PC is ON. Doing so may cause data to be lost, or may damage the CPU or Memory Pack.

2. Set the selector switches on the Memory Pack to the desired positions (refer to *Section 2-6 Memory Packs*).
3. Insert the Memory Pack into its compartment as shown below. As you do this, you will feel a slight resistance as the connector on the Memory Pack mates with the connector on the CPU. Continue pushing on the Memory Pack until it is inserted completely into the CPU.

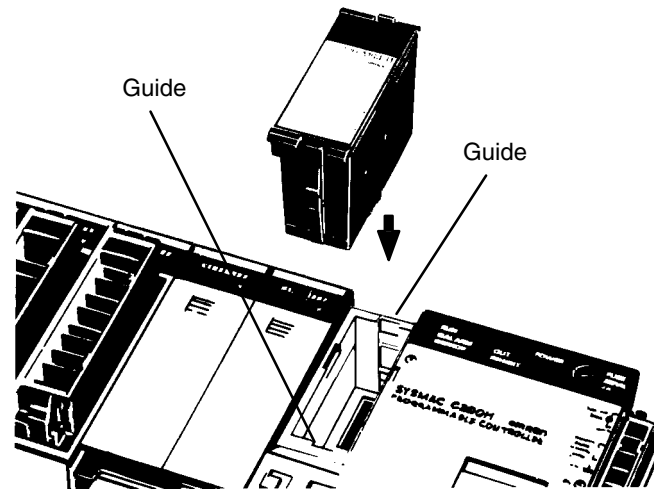

## 3-3 System Configurations

When building your C200H system there may be some restrictions depending on the Unit you are using and the Rack you are mounting it to. The following figure shows an assembled CPU Rack, Expansion I/O Rack, and Remote I/O Slave Rack. Use it as a quick reference when assembling your PC. For details about the individual Units, refer to that Unit's operation manual.

The items listed below should be kept in mind.

- The SYSMAC LINK Unit and the SYSMAC NET Link Unit are always mounted to either of the two slots to the left of the C200H-CPU11-E CPU. When using SYSMAC NET, a power supply adapter is mounted to the left of the Units.
- The C200H-OC225/OD212/OD21A 16-point Output Unit and C200H-B7AO1 B7A Interface Unit can be mounted only to a C200H-BC□□1-V1/V2 Back-plane.

**Special I/O Units**

- Up to ten Special I/O Units can be mounted.
- Mount Special I/O Units to any slot on the CPU Rack (except the two slots to the left of the CPU) or the Expansion I/O Rack.

**Host Link Unit and Remote I/O Master Unit**

- Up to two Units can be mounted.
- Host Link Units and Remote I/O Master Units can be mounted to any slot on the CPU Rack (except the two slots to the left of the CPU) or the Expansion I/O Rack.

**I/O Units**

- I/O Units available with 5, 8, 12, or 16 points.
- Units available with 10- or 19-terminal terminal blocks.
- Units with 5 and 8 points have 10-terminal terminal blocks and Units with 10 and 12 points have 19-terminal terminal blocks.
- There are some restrictions on the mounting position of 19-terminal I/O Units (refer to *Appendix B Specifications*).

**Memory Packs**

- RAM, EPROM, or EEPROM Packs available.
- EEPROM requires an optional EEPROM Chip.
- EPROM requires a separately available EPROM Chip.

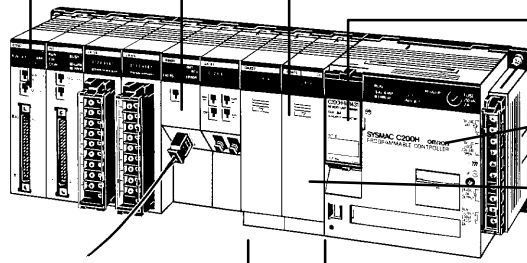

**CPU**  
Built-in power supply

**I/O Unit Cover**  
For 10-terminal block I/O Units

**Backplane**  
3-, 5-, 8-, 10-slot types available

**SYSMAC NET LINK Unit and SYSMAC LINK Unit**

- Use up to two Units, mounted to either of the two slots to the left of the CPU.
- When using either of these two Units the use of peripheral devices is limited. Refer to *Section 4-3 Maximum Current and Power Supplied*.

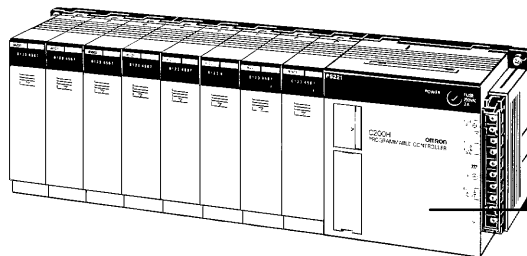

**Expansion I/O Racks**  
Up to two Expansion I/O Racks can be connected to one CPU Rack.

**Expansion I/O Power Supply**

**I/O Connecting Cable**

- Available in lengths from 30 cm to 1 m.
- Total length of I/O Connecting Cables between all Racks must not exceed 12 m.

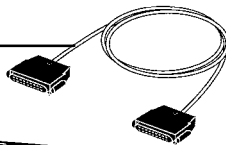

**Remote I/O Slave Unit**  
Up to five Units can be connected.

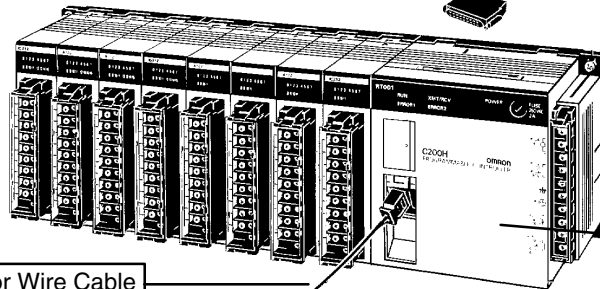

**Backplane**  
3-, 5-, or 8-slot types available

**Remote I/O Slave Unit**  
Power supply built-in

Optical Fiber Cable or Wire Cable

# SECTION 4

## System Connections

In the preceding sections we have covered what all the parts of a PC are and how they should be assembled. This section provides detailed information about the types of considerations involved in making all of the PC connections. Also included in this section are considerations that should be kept in mind when using the C200H-CPU11-E as the CPU.

- 4-1 IR Word Allocation .....
- 4-2 Remote I/O .....
- 4-3 Maximum Current and Power Supplied .....
- 4-4 I/O Connections .....

## 4-1 IR Word Allocation

Each slot of the Backplane is assigned a hardware word number. This word is accessible for I/O use only in the given slot. However, standard I/O Units are available in 5-, 8-, 12-, and 16-point models. If an I/O Unit other than a 16-point model is mounted, the unused points of that word are accessible only as “work bits” (refer to the C200H Operation Manual). The number of I/O bits available for the entire system, therefore, varies according to the model of I/O Units used, as well as the model of Backplanes used. The figure below shows the relationship between the model of I/O Unit and work bits. The shaded bits can only be used as work bits.

5-point Unit	8-point Unit	12-point Unit	16-point Unit
00	00	00	00
01	01	01	01
02	02	02	02
03	03	03	03
04	04	04	04
05	05	05	05
06	06	06	06
07	07	07	07
08	08	08	08
09	09	09	09
10	10	10	10
11	11	11	11
12	12	12	12
13	13	13	13
14	14	14	14
15	15	15	15

The CPU Rack begins with word 000 at the leftmost slot. The first Expansion I/O Rack begins with word 010, and the second Expansion I/O Rack with word 020. The first word of each Rack is fixed, regardless of the model of Backplane used. As with the I/O bits unused by individual I/O Units, the bits of the I/O words unused by a Backplane can be used as work bits. The following figure shows the relationship between the model of Backplane and I/O words. The shaded bits can only be used as work bits.

**C200H-BC031 Backplane**

Word	000	001	002	003	004	005	006	007	008	009
bits	00 } 15	00 } 15	00 } 15	00 } 15	00 } 15	00 } 15	00 } 15	00 } 15	00 } 15	00 } 15

**C200H-BC051-V1 Backplane**

Word	000	001	002	003	004	005	006	007	008	009
bits	00 } 15	00 } 15	00 } 15	00 } 15	00 } 15	00 } 15	00 } 15	00 } 15	00 } 15	00 } 15

**C200H-BC081-V1 Backplane**

Word	000	001	002	003	004	005	006	007	008	009
bits	00 } 15	00 } 15	00 } 15	00 } 15	00 } 15	00 } 15	00 } 15	00 } 15	00 } 15	00 } 15

**Note** The C200H-OC225/OD212/OD21A 16-point Output Unit and C200H-B7A01 B7A Interface Unit can be mounted only to a C200H-BC 1-V1/V2 Backplane.

For example, if a PC consists of three 8-slot Racks with 8-point I/O Units mounted to all I/O Unit mounting positions, the number of I/O points for the entire PC will be:

$$8 \text{ points} \times 8 \text{ slots} \times 3 \text{ Racks} = 192 \text{ points}$$

If a PC consists of three 8-slot Racks with the I/O Unit mounting positions equally divided between 16-point Input Units and 12-point Output Units, the number of I/O points for the entire PC will be:

$$\begin{aligned} \text{Input points} &= 16 \text{ points} \times 4 \text{ slots} \times 3 \text{ Racks} = 192 \text{ points} \\ \text{Output points} &= 12 \text{ points} \times 4 \text{ slots} \times 3 \text{ Racks} = 144 \text{ points} \\ \text{Total I/O points} &= 192 + 144 = 336 \end{aligned}$$

The following figure shows the word allocation for a fully expanded C200H with three 8-slot Backplanes.

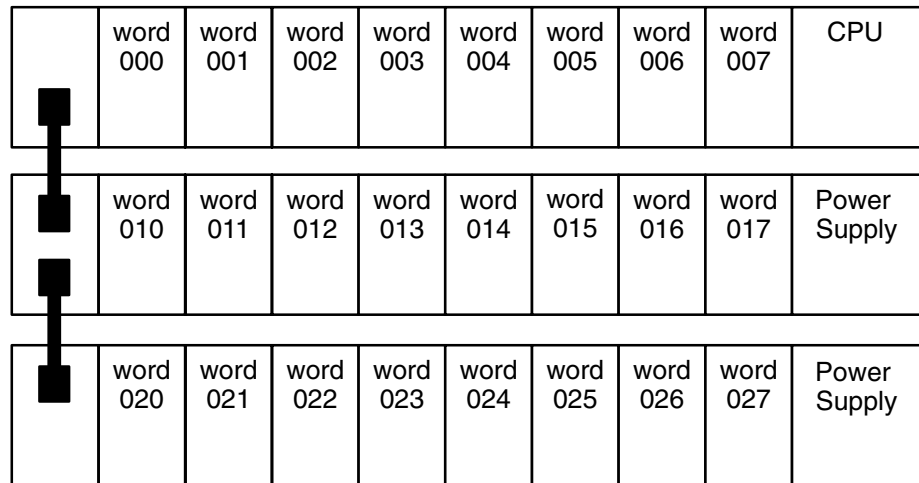

## 4-2 Remote I/O

There are limits to how long the normal wiring between the PC and its Expansion I/O Racks can be. A Remote I/O Unit can extend this distance greatly, so that the PC and its Expansion I/O Racks can even be located in separate buildings. There are two types of Remote I/O Systems, optical and wired.

By locating a Rack farther from the CPU Rack, a Remote I/O System eliminates the time and mess in wiring (or changing wiring) to many devices that are separated from the CPU Rack. Although all I/O points must ultimately be wired individually, the question is one of distance: Do you want to wire dozens of terminals all the way across a factory complex or do you want to run a single cable for most of the distance and then wire individual terminals locally? A PC with an Expansion I/O System is called an Expanded PC.

I/O words 100 through 199 and DM words 1000 through 1999 are allocated to Special I/O Units. There are limitations to the number and model of Special I/O Units that can be mounted to a Remote I/O Slave Rack. Provided no other models of Special I/O Units are mounted to a Remote I/O Slave Rack, the maximum number of Special I/O Units that can be mounted is shown below for each model.

Group	Units	Total number
A	High-speed Counter, Position Control (NC111/NC112), ASCII, Analog I/O, ID Sensor, Fuzzy Logic Unit	4 Units
B	High-density and Mixed I/O, Cam Positioner, Temperature Control, PID Control, Heat/Cool Temperature Control	8 Units
C	Temperature Sensor, Voice	6 Units
D	Position Control (NC221)	2 Units

When using a combination of A, B, C, and D Units on a Remote I/O Slave Rack, the number of each model of Unit being used must satisfy the following two formulas.

$$3A + B + C + 6D \leq 12$$

$$A + B + C + D \leq 8$$



In addition, when PC Link Units are used, a maximum of ten Special I/O Units and PC Link Units total can be mounted to one Expanded PC. When a High-density I/O Unit is mounted to a Remote I/O Slave Rack, the RM001-PV1 or RM201 Remote I/O Master Unit must be used.

### 4-3 Maximum Current and Power Supplied

The power supplies, including those built in the CPUs, are limited in the total current they can supply to I/O units.

The table below shows the maximum currents supplied by each power supply. There are three categories in the “Maximum current supplied”:

- 1, 2, 3... 1. The 5-V internal logic current powers I/O Cards and communications cards. Refer to the deductions table to determine what trade-offs must be made when the total I/O and peripherals exceed the CPUs internal logic current capacity.
2. The 26-V relay current powers relay output cards and ID Sensor Units.
3. Finally, the external 24-VDC power supply on the CPU powers external input devices.

The total wattage of all three categories cannot exceed the wattage listed in the last column, “Maximum power”.

You should not exceed any of the individual current ratings for the voltage supplied by any single unit, nor should you exceed the total maximum power output.

#### Current Supplied

Name	Model number	Max. current supplied			Maximum power
		5 V (internal logic current)	26 V (relay current)	24 V (No-voltage contact current)	
CPU Rack	C200H-CPU01-E	1.6 A	0.6 A	0.8 A	23 W
	C200H-CPU03-E			---	18 W
	C200H-CPU11-E	1.4 A		0.8 A	22 W
Expansion I/O Rack	C200H-PS221	2.7 A	0.6 A	0.8 A	28 W
	C200H-PS211			---	23 W
Slave Rack	C200H-RT001-P	2.7 A	0.6 A	0.8 A	28 W
	C200H-RT002-P			---	23 W
	C200H-RT201			0.8 A	28 W
	C200H-RT202			---	23 W

**Note** The figures shown in the “maximum current supplied” and “maximum power supplied” columns are computed with the power consumed by the Backplanes, CPU, Memory Cassettes, Peripheral Devices, I/O Power Supply Units, and Slave Units already calculated.

Design the system so that the following two conditions are satisfied.

**Condition 1**

- (1) (Total current consumption of all Units in the 5-V system) ≤ (the figure in the 5-V column)
- (2) (Total current consumption of all Units in the 26-V system) ≤ (the figure in the 26-V column)
- (3) (Total current consumption of all Units in the 24-V system) ≤ (the figure in the 24-V column)

**Condition 2**

(1) x 5 V + (2) x 26 V + (3) x 24 ≤ (maximum power supplied)

Deductions Table

CPU11-E 5-V consumption (I/O card)	CPU01/03-E 5-V consumption (I/O card)	Peripheral device deductions
≤ 1.4 A	≤ 1.6 A	None
> 1.4 A, but ≤ 1.7 A	> 1.6 A, but ≤ 1.9 A	PROM Writer and CPU-mounting Host Link Unit
> 1.7 A, but ≤ 1.9 A	> 1.9 A, but ≤ 2.1 A	PROM Writer, CPU-mounting Host Link Unit, Peripheral Interface Unit
> 1.9 A, but ≤ 2.1 A	> 2.1 A, but ≤ 2.3 A	PROM Writer, CPU-mounting Host Link Unit, Peripheral Interface Unit, and Printer Interface Unit

Current Drawn from 5-V Supply

Unit	Model number	Current consumption
DC Input	C200H-ID211	0.01 A each
	C200H-ID212	
No-Voltage Contact Input	C200H-ID001	
	C200H-ID002	
AC Input	C200H-IA121	
	C200H-IA122/IA122V	
	C200H-IA221	
	C200H-IA222/IA222V	
AC/DC Input	C200H-IM211	
	C200H-IM212	
Contact Output	C200H-OC221	
	C200H-OC222	
	C200H-OC223	
	C200H-OC224	
	C200H-OC225	
Transistor Output	C200H-OD411	0.14 A
	C200H-OD211	0.16 A
	C200H-OD212	0.18 A
	C200H-OD213	0.14 A
	C200H-OD214	0.01 A each
	C200H-OD216	
	C200H-OD217	0.16 A
C200H-OD21A		
Triac Output	C200H-OA121-E	0.14 A
	C200H-OA122-E	0.18 A
	C200H-OA223	0.18 A
	C200H-OA222V	0.20 A
	C200H-OA224	0.27 A
Analog Timer Unit	C200H-TM001	0.06 A
B7A Interface Unit	C200H-B7AI1	0.10 A
	C200H-B7AO1	
Host Link	C200H-LK101-PV1	0.25 A
	C200H-LK201-V1	0.15 A
	C200H-LK202-V1	0.25 A
PC Link	C200H-LK401	0.35 A
Remote Master	C200H-RM001-PV1	0.20 A
	C200H-RM201	0.25 A
SYSMAC LINK Unit	C200HW-SLK13/SLK14/SLK23/SLK24	0.8 A

Unit	Model number	Current consumption
SYSMAC NET Link Unit	C200HS-SNT32	1.0 A
Feed Adapter	C200H-APS01/ASP02	0 A
TTL Input	C200H-ID501	0.13 A
DC Input	C200H-ID215	
TTL Output	C200H-OD501	0.22 A
Transistor Output	C200H-OD215	
TTL I/O	C200H-MD501	0.18 A
DC Input/Transistor Output	C200H-MD115	
	C200H-MD215	
High-speed Counter	C200H-CT001-V1	0.30 A
	C200H-CT002	
Position Control	C200H-NC111	0.15 A
	C200H-NC112	0.15 A
	C200H-NC211	0.50 A
Analog Input	C200H-AD001	0.55 A
	C200H-AD002	0.45 A
Analog Output	C200H-DA001	0.65 A
	C200H-DA002	0.6 A
Temperature Control Units	C200H-TC001	0.33 A
	C200H-TC002	
	C200H-TC003	
	C200H-TC101	
	C200H-TC102	
	C200H-TC103	
Heat/Cool Temperature Control Units	C200H-TV001	0.33 A
	C200H-TV002	
	C200H-TV003	
	C200H-TV101	
	C200H-TV102	
	C200H-TV103	
PID Control Units	C200H-PID01	0.33 A
	C200H-PID02	
	C200H-PID03	
Temperature Sensor Input	C200H-TS001/TS002	0.45 A
	C200H-TS101/TS102	0.35 A
ASCII	C200H-ASC02	0.15 A
Voice Output	C200H-OV001	0.30 A
ID Sensor	C200H-IDS01-V1	0.25 A
	C200H-IDS21	
Fuzzy Logic Unit	C200H-FZ001	0.30 A
Cam Positioner	C200H-CP114	0.30 A

**Current Drawn from 26-V Supply**

Unit	Model number	Current consumption
Contact Output	C200H-OC221/OC222/OC223/OC224/OC225	0.075 A*
	C200H-OD216/OD217	
ID Sensor	C200H-IDS01-V1/IDS21	0.12 A

**Note** \*With all eight bits on simultaneously.

**Current Drawn from 24-V Supply**

Unit	Model number	Current consumption
No-Voltage Contact Input Units	C200H-ID001/ID002	0.06 A

**Calculation Examples**

The total power consumption for each Rack can be obtained from the following formulas:

$$\text{CPU Rack} = \frac{\text{Total power consumption for each Unit} + 7 (8)}{0.6 \times 0.55 (1)} \quad (\text{VA})$$

7 = CPU power consumption, (8) = Power consumption of the CPU11-E  
 0.6 = 60% efficiency  
 0.55 (1) = Power rate (Number in parentheses: when CPU03-E is used.)

$$\text{All other Racks} = \frac{\text{Total power consumption for each Unit} + 2}{0.6 \times 0.55 (1)} \quad (\text{VA})$$

2 = I/O Power Supply Unit (Remote I/O Slave Unit) power consumption  
 0.6 = 60% efficiency  
 0.55 (1) = Power rate (Number in parentheses: when PS211, RT002-P or RT202 is used.)

**Example 1**

Assume that four Contact Output Units, three No-Voltage Contact Input Units, and one Host Link Unit are mounted to a Rack, along with CPU01-E. The following table shows how the total power consumption is calculated.

Voltage	Current consumption	Power consumption
5 V	(1) $0.01 \times 7 + 0.25 = 0.32 \text{ A} (\leq 1.6 \text{ A})$	(1) $\times 5 \text{ V} = 1.6 \text{ W}$
26 V	(2) $0.075 \times 4 = 0.30 \text{ A} (\leq 0.6 \text{ A})$	(2) $\times 26 \text{ V} = 7.8 \text{ W}$
24 V	(3) $0.06 \times 3 + 0.3 = 0.48 \text{ A} (\leq 0.8 \text{ A})$	(3) $\times 24 \text{ V} = 11.52 \text{ W}$
Total	---	20.92 W ( $\leq 23 \text{ W}$ )

**Example 2**

Assume that six DC Input Units and two High-speed Counter Units are mounted to a Rack, along with the PS221 Power Supply. The following table shows how the total power consumption is calculated.

Voltage	Current consumption	Power consumption
5 V	(1) $0.01 \times 6 + 0.3 \times 2 = 0.66 \text{ A} (\leq 2.7 \text{ A})$	(1) $\times 5 \text{ V} = 3.3 \text{ W}$
26 V	(2) 0	(2) 0
24 V	(3) Service power supply = 0.8 A ( $\leq 0.8 \text{ A}$ )	(3) $\times 24 \text{ V} = 19.2 \text{ W}$
Total	---	22.5 W ( $\leq 28 \text{ W}$ )

**Example 3**

Assume that the following Units are mounted to a Rack to which a C200H-CPU11-E is mounted. The following table shows how the total power consumption is calculated.

Voltage	Current consumption	Power consumption
5 V	(1) $0.01 \times 6 + 0.18 = 0.24 \text{ A} (\leq 1.1 \text{ A})$	(1) $\times 5 \text{ V} = 1.2 \text{ W}$
26 V	(2) $0.075 \times 4 = 0.30 \text{ A} (\leq 0.6 \text{ A})$	(2) $\times 26 \text{ V} = 7.8 \text{ W}$
24 V	(3) $0.06 \times 2 + 0.3 = 0.42 \text{ A} (\leq 0.8 \text{ A})$	(3) $\times 24 \text{ V} = 10.08 \text{ W}$
Total	---	19.08 W ( $\leq 20.5 \text{ W}$ )

- Peripheral Interface Unit (IP006)
- SYSMAC LINK Units (SLK22): 1
- Contact Output Units (OC221): 6
- No-Voltage Contact Input Units (ID001): 2

- High-density and Mixed I/O Units (MD215): 1
- Current for MD215: 0.3 A

**Example 4**

Assume that the following Units are mounted to a rack to which is mounted the C200H-CPU11-E. The following table shows how the total power consumption is calculated.

Voltage	Current consumption	Power consumption
5 V	(1) $0.01 \times 5 + 0.3 \times 1 = 0.35 \text{ A} (\leq 0.7 \text{ A})$	(1) $\times 5 \text{ V} = 1.75 \text{ W}$
26 V	(2) 0	(2) 0
24 V	(3) Current=0.5 A( $\leq 0.8 \text{ A}$ )	(3) $\times 24 \text{ V} = 12 \text{ W}$
Total	---	13.75 W ( $\leq 18.5 \text{ W}$ )

- Peripheral Interface Unit (IP006)
- SYSMAC NET Link Units (SNT32): 1
- Central Power Supply Adapter (Current 0): 1
- DC Input Units (ID212): 5
- High-speed Counter Units (CT002): 1
- Current for ID212: 0.5 A

**Calculation of Power Consumption for Each Rack (Examples)**

The total power consumption for each Rack can be obtained from the following formulas:

- CPU Rack: 
$$\frac{\text{Total power consumption for each Unit} + 7 \text{ (8)}}{0.6 \times 0.55 \text{ (1)}} \text{ (VA)}$$

Where:

- 7 = Power consumption of the CPU,
- (8) = Power consumption of the CPU11-E,
- 0.6 = 60% efficiency, and
- 0.55 (1) = Power rate (Number in parentheses: when CPU03-E is used.)

- Expansion I/O Power Supply/Remote I/O Slave Unit: 
$$\frac{\text{Total power consumption for each Unit} + 2 \text{ (VA)}}{0.6 \times 0.55 \text{ (1)}}$$

Where:

- 2 = Power consumption of the I/O Power Supply or Remote I/O Slave Unit,
- 0.6 = 60% efficiency, and
- 0.55 (1) = Power rate (Number in parentheses: when PS211, RT002-P or RT202 is used.)

### 4-4 I/O Connections

Connect the I/O Devices to the I/O Units using AWG 22 (cross-sectional area of 0.3 mm<sup>2</sup>) for 19-terminal terminal blocks and AWG 22 to 18 lead wire (cross-sectional area of 0.3 to 0.75 mm<sup>2</sup>) for 10 terminal terminal blocks. The terminals have screws with 3.5-mm diameter heads and self-raising pressure plates. Connect the lead wires to the terminals as shown below. Tighten the screws with a torque of 0.8 N • m.

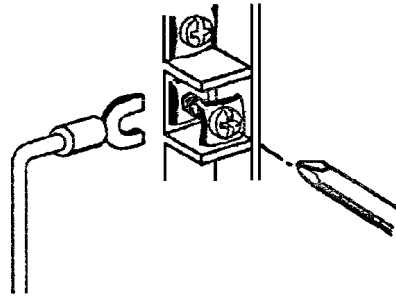

If you wish to attach solderless type terminals to the ends of the lead wires, use terminals having the dimensions shown below.



#### Terminal Block

The terminal block of an I/O Unit can be removed by loosening the mounting screws. You do not have to remove the lead wires from the terminal block in order to remove it from an I/O Unit.

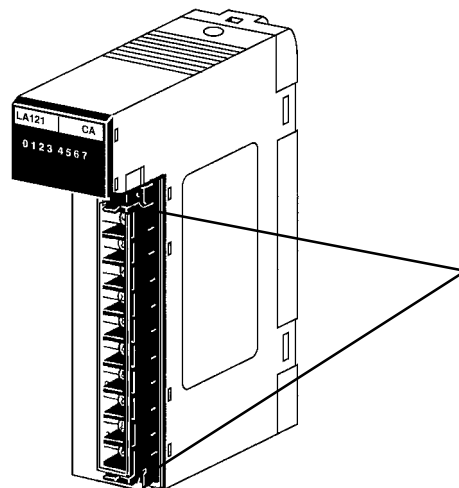

Locks for terminal block. Unlock to remove the terminal block from the I/O Unit. Make sure the terminal block is locked securely after wiring is complete.

**I/O Unit Cover**

A C200H-COV11 Cover is provided as an I/O Unit cover for Units that use 10P terminal block connectors. After the I/O wiring has been completed, slide the cover up from the bottom, as shown in the illustration below.

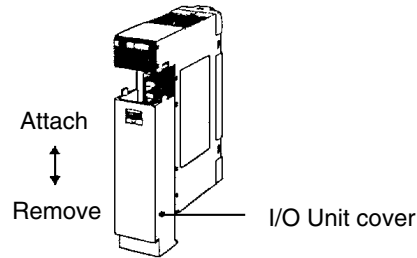

**DC Two-wire Sensor Connection Precautions**

If a two-wire sensor is used with a 12-VDC or 24-VDC input device, make sure that the following conditions are satisfied. Malfunctions will occur if these conditions are not satisfied.

- The relationship between the PC ON voltage and the sensor residual voltage is as follows:

$$V_{ON} \leq V_{CC} - V_R$$

- The relationship between the PC ON current and the sensor control output (load current) is as follows:

$$I_{OUT (min)} \leq I_{ON} \leq I_{OUT (max)}$$

$$I_{ON} = (V_{CC} - V_R - 1.5 \text{ (PC internal residual voltage)}) / R_{IN}$$

Connect R bleeder resistance if  $I_{ON}$  is less than  $I_{OUT (min)}$ .

The constant for bleeder resistance is determined by the following equation.

$$R \leq (V_{CC} - V_R) / (I_{OUT (min)} - I_{ON})$$

$$\text{Power } W \leq (V_{CC} - V_R)^2 / R \times 4 \text{ (margin)}$$

- The relationship between the PC OFF current and sensor leakage current is as follows:

$$I_{OFF} \leq I_{leak}$$

Refer to the information on input and output leakage current on page 56 for details.

The value of  $I_{OFF}$  depends on the Unit used. For Input Units that have an unspecified OFF current, however, the value of  $I_{OFF}$  is always 1.8 mA.

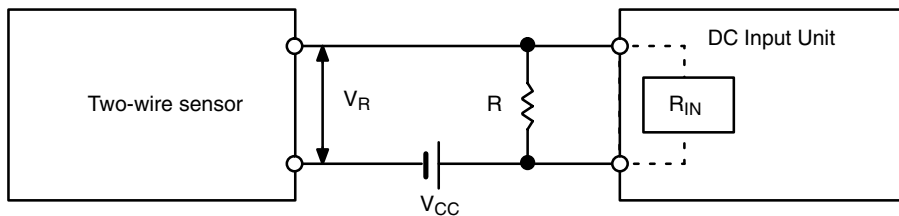

$V_{CC}$ :	Power supply voltage	$V_R$ :	Sensor output residual voltage
$V_{ON}$ :	PC ON voltage	$I_{OUT}$ :	Sensor control output (load current)
$I_{ON}$ :	PC OFF current	$I_{leak}$ :	Sensor leakage current
$I_{OFF}$ :	PC OFF current	R:	Bleeder resistance
$R_{IN}$ :	PC input impedance		

**Wiring Examples**

The following are examples of how to connect I/O devices to I/O Units. During wiring, work slowly and carefully. If an input device is connected to an Output Unit, damage may result. Check all I/O devices to make sure they meet the specifications (refer to *Appendix B Specifications*).

DC Input Units

Contact output

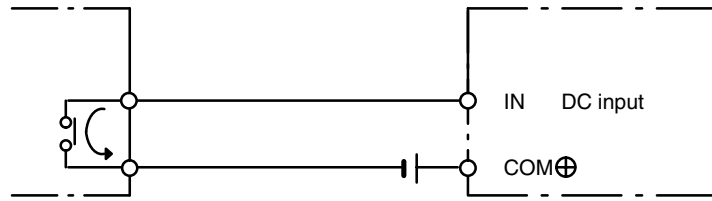

When using the configuration shown below, the sensor and Input Unit should receive their power from the same supply.

NPN current output

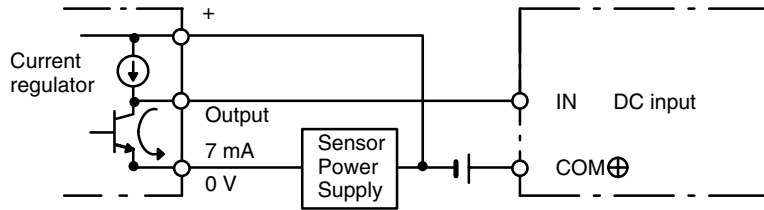

NPN open-collector output

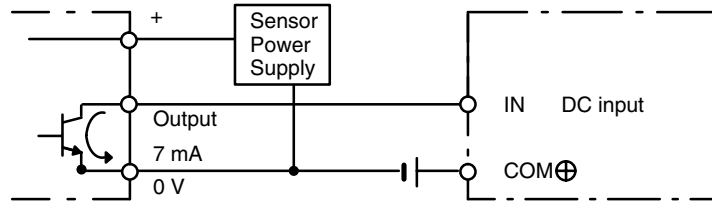

PNP current output

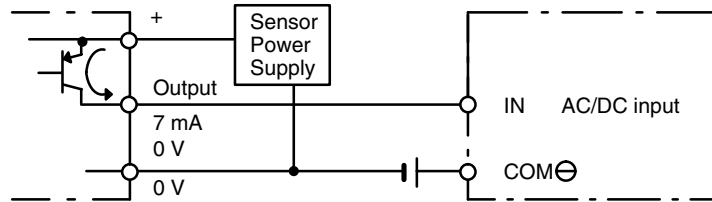

The circuit below should be used for I/O devices having a voltage output.

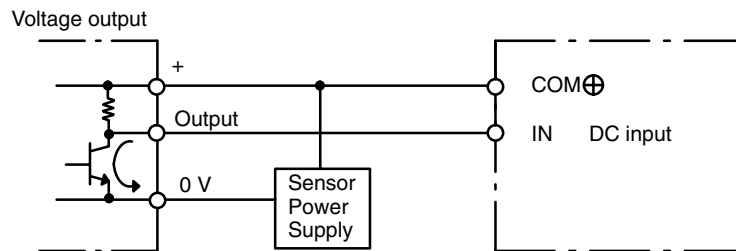

The circuit below should **NOT** be used for I/O devices having a voltage output.

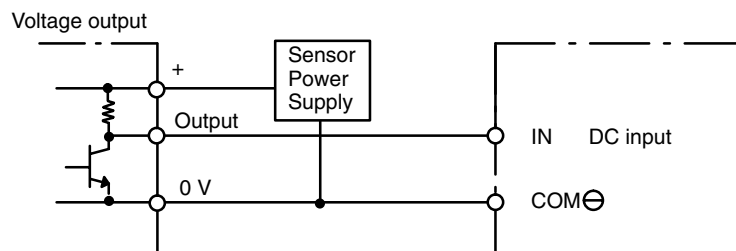



**AC Input Units**

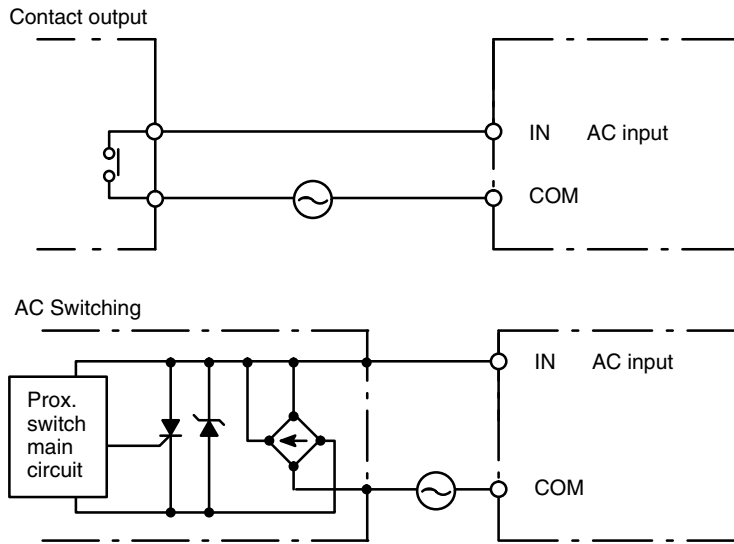

**Caution** When using Reed switch as the input contacts for AC Input Units, be sure the allowable current of the switch is at least 1 A. Using switches with lower capacities may cause the contacts to fuse due to surge current.

**Output Units**

A fuse placed in the output circuit will protect the output element, circuit board, etc., in the event of a short circuit in the output circuit. Although some transistor Output Units and Triac Output Units have a built-in fuse, it is recommended that you connect an external fuse to each Output Unit for extra safety and ease of maintenance.



# SECTION 5

## Installation Environment

This section details the necessary environment and conditions for installation of the PC. For specific instructions on mounting Units and wiring for I/O and power, refer to *Section 2-4 Power Supply* and *Section 3-3 System Configurations*.

5-1	Installation Environment .....
5-2	Mounting Requirements .....
5-3	Duct Work .....
5-4	Preventing Noise .....

## 5-1 Installation Environment

This section details the necessary environmental conditions for installing the PC.

**Caution**

Static electricity can damage PC components. Your body can carry an electrostatic charge, especially when the humidity is low. Before touching the PC, be sure to first touch a grounded metallic object, such as a metal water pipe, in order to discharge any static build-up.

**Ambient Conditions**

Do not install the PC in any of the following locations. Doing so will affect PC life and may affect operating performance.

- Locations subject to ambient temperatures lower than 0°C or higher than 55°C.
- Locations subject to drastic temperature changes or condensation.
- Locations subject to ambient humidity lower than 10% or higher than 90%.
- Locations subject to corrosive or flammable gases.
- Locations subject to excessive dust (especially iron dust) or chloride.
- Locations that would subject the CPU to direct shock or vibration.
- Locations that would subject the PC to water, oil, or chemical reagents.
- Locations exposed to direct sunlight.

**Cooling**

There are two points to consider in order to ensure that the PC does not overheat. The first is the clearance between Racks, and the second is installation of a cooling fan.

**Clearance Between Racks**

The Racks need to have sufficient room between each other to allow for I/O wiring, and additional room to ensure that the I/O wiring does not hamper cooling. However, the Racks must be mounted close enough to each other that the length of the Connecting Cable between any two Racks does not exceed 10 m, and the total length of the Connecting Cables between all Racks does not exceed 12 m. As a general rule, about 70 to 120 mm should be left between any two Racks.

**Cooling Fan**

A cooling fan is not always necessary, but may be needed in some installations. Try to avoid mounting the PC in a warm area, or over a source of heat. A cooling fan is needed if the ambient temperature may become higher than that specified (refer to *Appendix B Specifications*). If the PC is mounted in an enclosure, a cooling fan may need to be installed, as shown below, to maintain the ambient temperature within specifications.

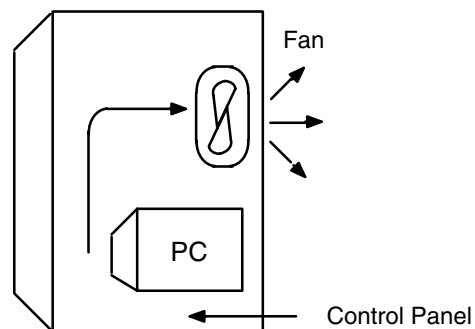

## 5-2 Mounting Requirements

The PC consists of from one to three Racks. Each Rack must be mounted vertically, that is with the printing on the front panels oriented as it would normally be read. The Racks should be mounted one above the other with the CPU Rack uppermost as shown below.

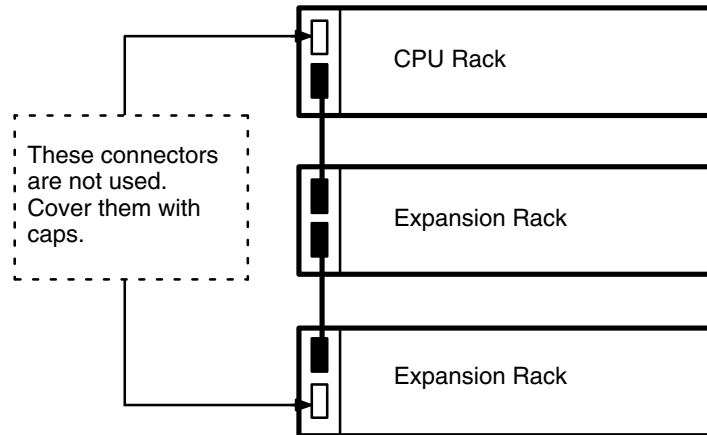

The C200H is approved by Underwriters Laboratories under the condition that, "The device must be mounted vertically for ventilation purposes".

### DIN Rail Mounting

The PC may be mounted using DIN Rail if desired. This type of mounting is not required, and the PC may be directly mounted to any sturdy support meeting the environmental specifications (refer to *Appendix B Specifications*). If you want to mount the PC on DIN Rail, you can order a DIN Rail from OMRON (refer to *Appendix B Standard Models*). DIN Rails come in the two heights shown below.

#### 7.3-mm Height

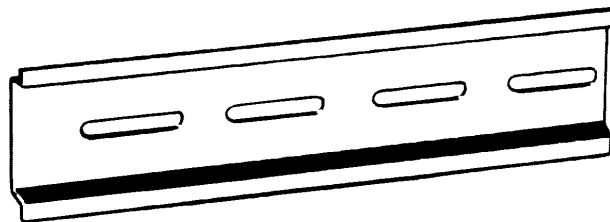

#### 16-mm Height

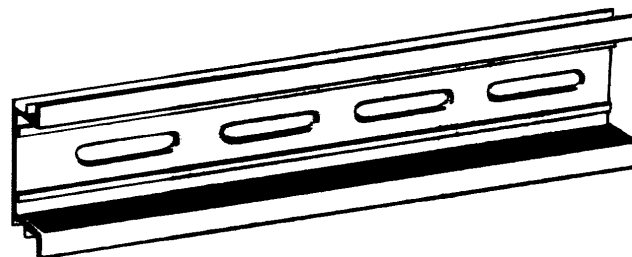

**DIN Rail Mounting Bracket**

The DIN Rail Mounting Bracket shown below is necessary for mounting the PC to the DIN Rail.



**Procedure**

- 1, 2, 3... 1. The following diagram is a view of the back of the Backplane. Attach one Mounting Bracket to the left and right sides of the Backplane as shown below.

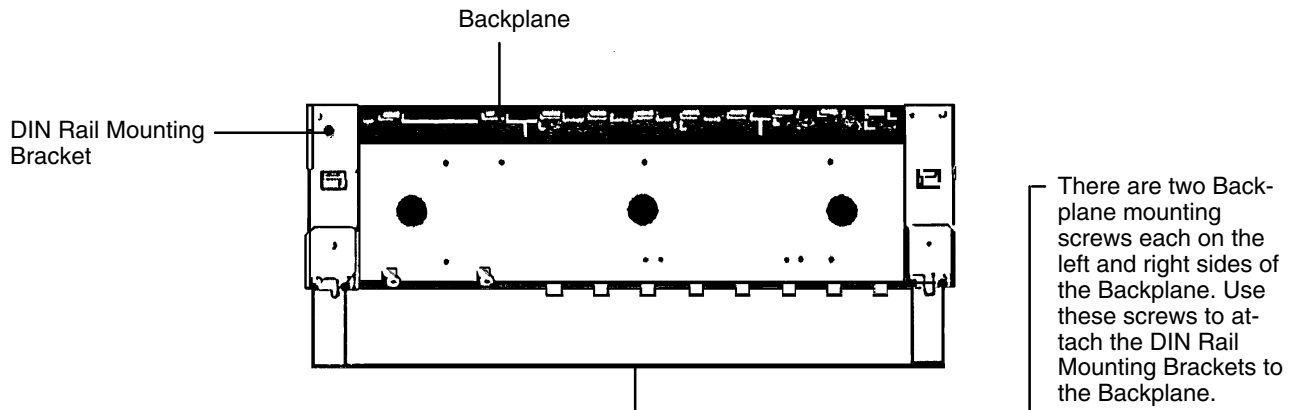

2. Mount the Backplane to the DIN Rail so that the claws on the Mounting Brackets fit into the upper portion of the DIN Rail as shown below.

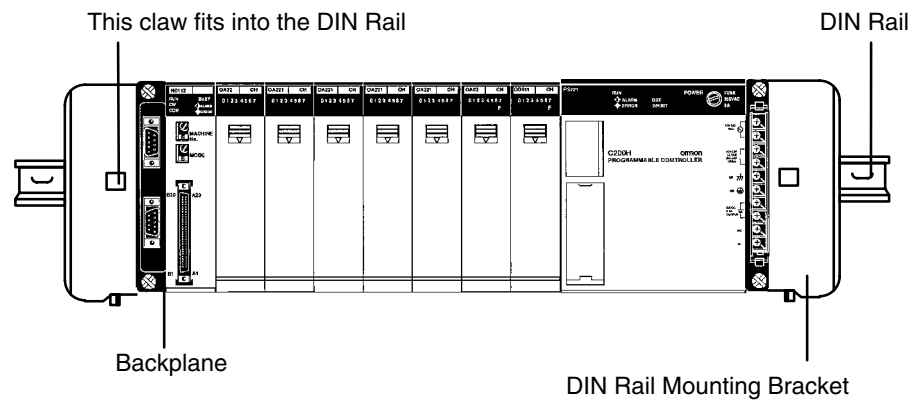

- Loosen the screws attaching the Mounting Brackets to the Backplane. Slide the Backplane upward as shown below so that the Mounting Bracket and Backplane clamp securely onto the DIN Rail. Tighten the screws.

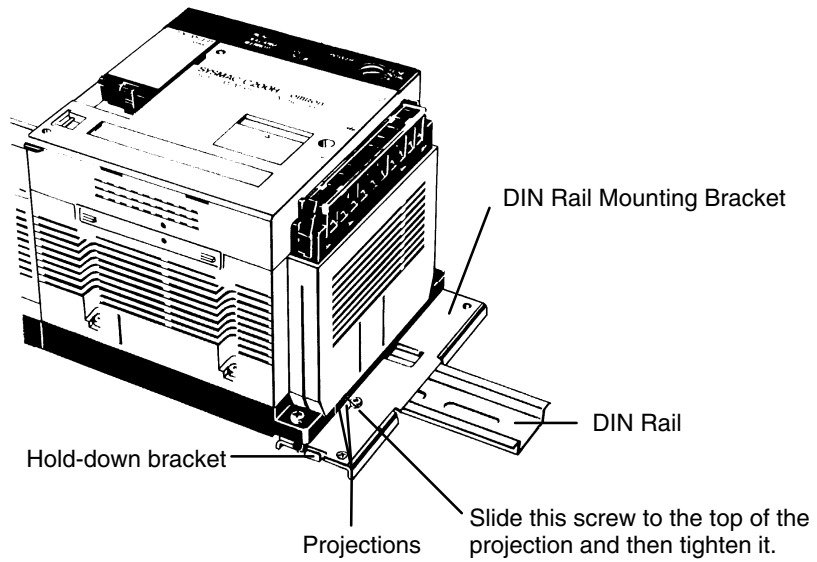

### 5-3 Duct Work

If power cables carrying more than 10 A 400 V, or 20 A 220 V must be run alongside the I/O wiring (that is, in parallel with it), at least 300 mm must be left between the power cables and the I/O wiring as shown below.

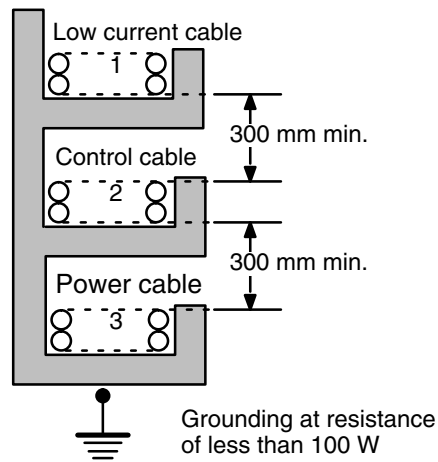

Where: 1 = I/O wiring  
 2 = General control wiring  
 3 = Power cables

If the I/O wiring and power cables must be placed in the same duct (for example, where they are connected to the equipment), they must be shielded from each other using grounded metal plates.

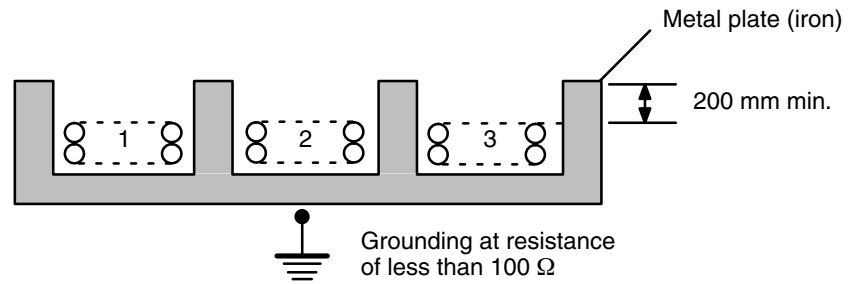

Where: 1 = I/O wiring  
2 = General control wiring  
3 = Power cables

## 5-4 Preventing Noise

In order to prevent noise from interfering with the operation of the PC, use AWG 14 twisted-pair cables (cross-sectional area of at least 2 mm<sup>2</sup>). Avoid mounting the PC close to high-power equipment, and make sure the point of installation is at least 200 mm away from power cables as shown in the following diagram.

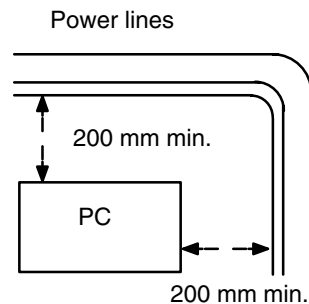

Whenever possible, use wiring conduit to hold the I/O wiring. Standard wiring conduit should be used, and it should be long enough to completely contain the I/O wiring and keep it separated from other cables.



# SECTION 6

## Power Considerations

Use a commercially available 100 to 120 VAC, 200 to 240 VAC, or 24 VDC power source, according to the model of PC you are using (refer to *Appendix B Specifications*). Expansion I/O Racks, if used, must also be connected to the power source. If possible, use independent power sources for the PC, input devices, and output devices. All Racks of the PC may be connected to one power source.

- 6-1 Grounding .....
- 6-2 Insulation .....
- 6-3 Emergency Stop .....
- 6-4 Wiring .....

## 6-1 Grounding

The Line Ground (LG) terminal is a noise-filtered neutral terminal that does not normally require grounding. If electrical noise is a problem, however, this terminal should be connected to the Ground (GR) terminal.

To avoid electrical shock, attach a grounded (earth ground) AWG 14 wire (cross-sectional area of at least  $2 \text{ mm}^2$ ) to the GR terminal. The resistance to ground must be less than  $100 \Omega$ . Do not use a wire longer than 20 m. Care must be taken, because ground resistance is affected by environmental conditions such as soil composition, water content, time of year, and the length of time since the wire was laid underground.

PC operation may be adversely affected if the ground wire is shared with other equipment, or if the ground wire is attached to the metal structure of a building. When using an Expansion I/O Rack, the Rack must also be grounded to the GR terminal. The same ground can be used for all connections.

## 6-2 Insulation

If a separate ground is being supplied to different Racks, Insulating Plates must be used to insulate the Racks from each other. Insulating Plates are supplied as an accessory (refer to *Appendix B Specifications*).

## 6-3 Emergency Stop

An external relay should be used to form an emergency stop circuit that turns the power to the PC OFF in the event of an emergency. An emergency stop routine in the PC program is not sufficient to ensure safety. The circuit shown below is an example of an emergency stop circuit.

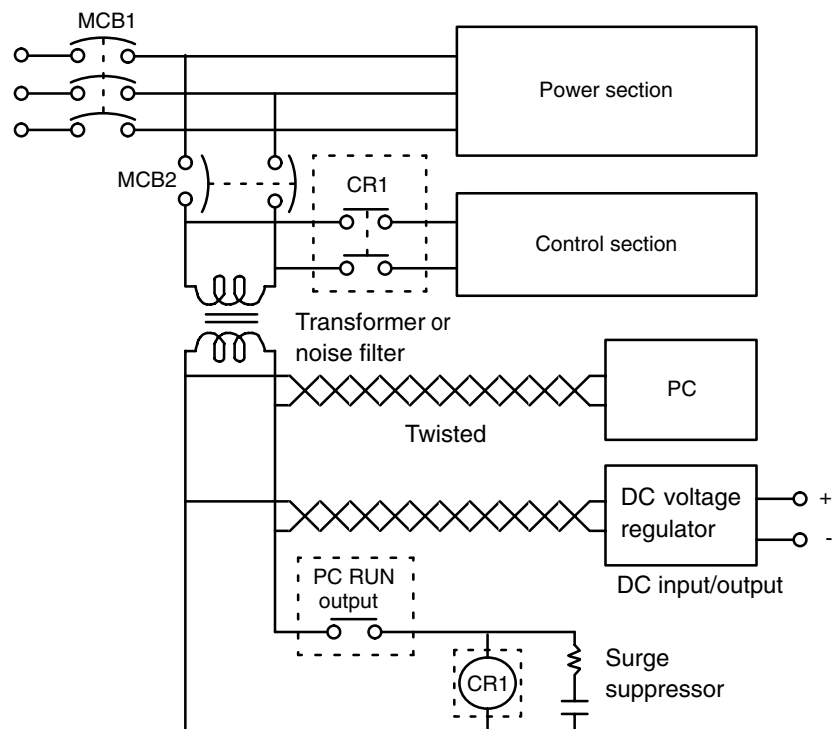

**Power Failure**

A sequential circuit is built into the PC to handle power interruptions. This circuit prevents malfunctions due to momentary power loss or voltage drops. A timing diagram for the operation of this circuit is shown below.

The PC ignores all momentary power failures if the interruption lasts no longer than 10 ms. If the interruption lasts between 10 and 25 ms, the interruption may or may not be detected. If the supply voltage drops below 85% of the rated voltage for longer than 25 ms (less for the DC Power Supply), the PC will stop operating and the external outputs will be automatically turned OFF. Operation is resumed automatically when the voltage is restored to more than 85% of the rated value.

**6-4 Wiring**

The following diagrams show the proper way to connect the power source to the PC. The terminals marked “NC” are not connected internally.

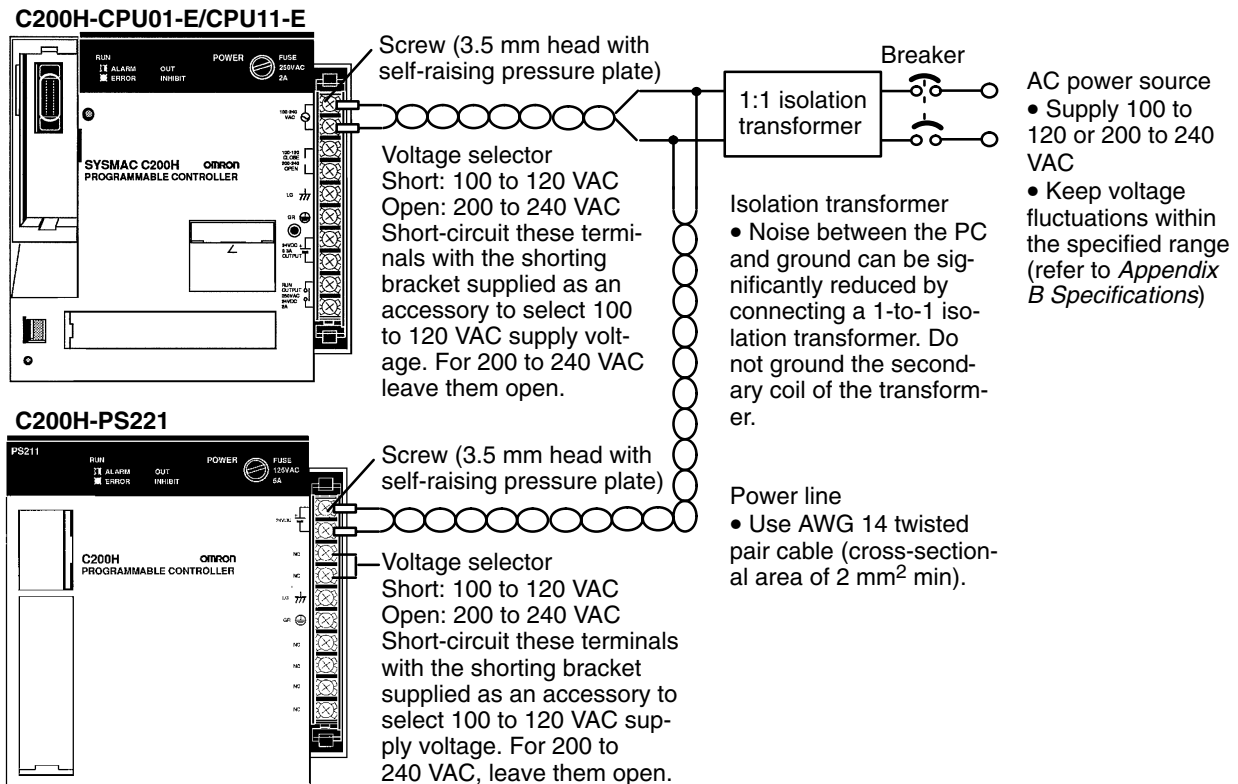

**AC Power Supply Wiring**

Use 1.25-mm<sup>2</sup> cables or larger. The terminal blocks have screws with 3.5-mm diameter heads and self-raising pressure plates. For connecting to the terminal blocks, use round crimp terminals for 3.5-mm diameter heads. Directly connecting stranded wires to the terminal blocks may cause a short-circuit.

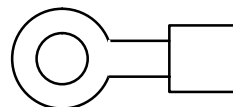

**Caution** Tighten the AC Power Supply terminals on the terminal blocks to the torque of 0.8 N • m. Insufficient tightening may cause short-circuiting, malfunction, or burning.

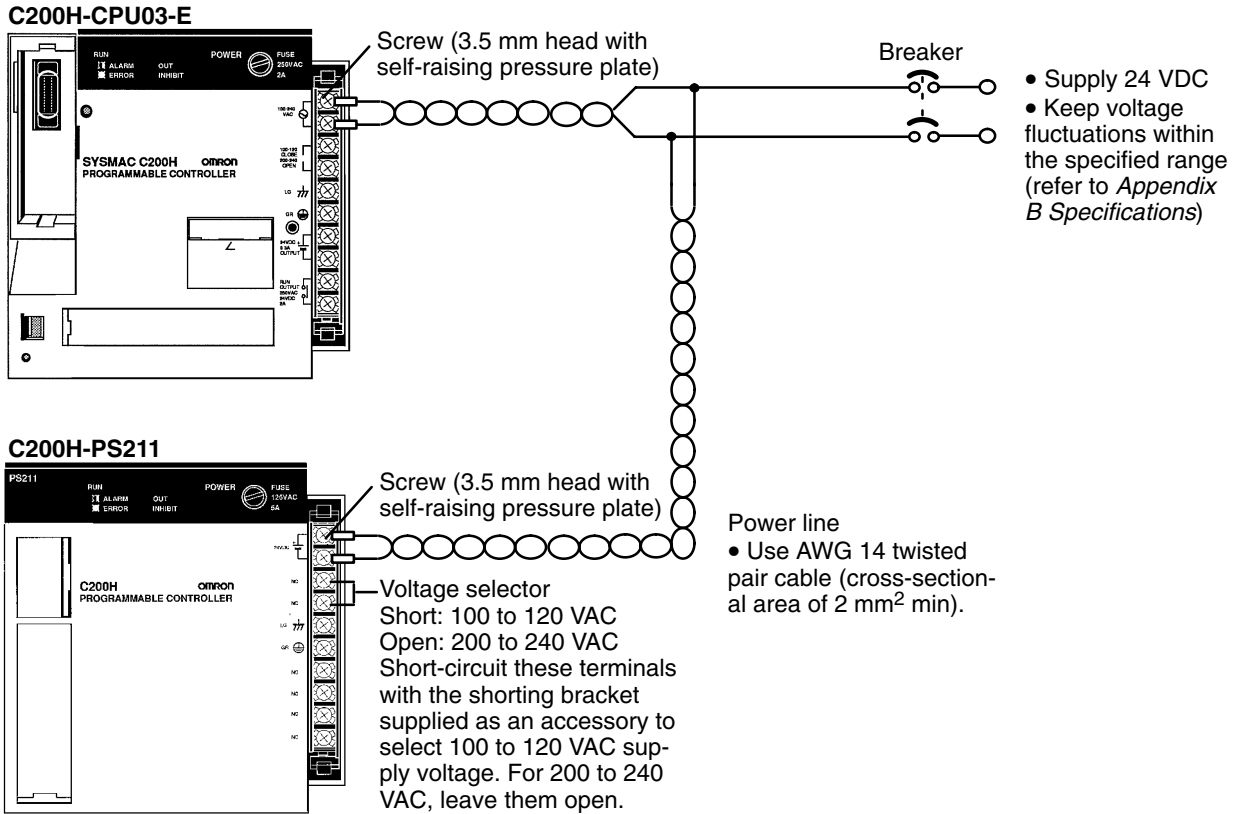

**Power Supply Wiring**

Use 1.25-mm<sup>2</sup> cables or larger. The terminal blocks have screws with 3.5-mm diameter heads and self-raising pressure plates. For connecting to the terminal blocks, use round crimp terminals for 3.5-mm diameter heads. Directly connecting stranded wires to the terminal blocks may cause a short-circuit.

Tighten the terminals on the terminal blocks to the torque of 0.8 N • m.



# SECTION 7

## Safety Considerations

There are certain safety requirements to be considered when installing the PC. Some of these, such as the emergency stop circuit (refer to *Section 2-4 Power Supply*), are part of the initial wiring. The considerations described below should be kept in mind when operating the PC and when connecting I/O devices to the PC.

- 7-1 Interlock Circuits .....
- 7-2 Wiring .....

## 7-1 Interlock Circuits

When the PC controls an operation such as the clockwise and counterclockwise operation of a motor, provide an external interlock such as the one shown below to prevent both the forward and reverse outputs from turning ON at the same time.

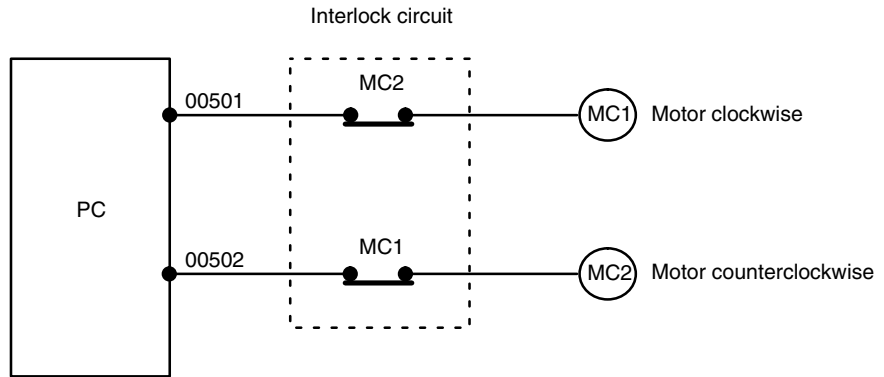

This circuit prevents outputs MC1 and MC2 from ever both being ON at the same time. Even if the PC is programmed improperly or malfunctions, the motor is protected.

## 7-2 Wiring

### Power Supply Output

The 24 VDC output of the CPU and Expansion I/O Power Supply may be used to power other devices. The output current of these supplies is limited to 0.3 A. A separate power supply must be provided if the devices being powered require a higher current.

### Input Leakage Current

When two-wire sensors, such as photoelectric sensors, proximity sensors, or limit switches with LEDs, are connected to the PC as input devices, the input bit may be turned ON erroneously by leakage current. In order to prevent this, connect a bleeder resistor across the input as shown below.

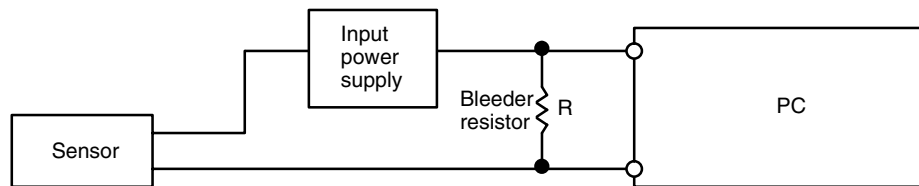

If the leakage current is less than 1.3 mA, there should be no problem. If the leakage current is greater than 1.3 mA, determine the value and rating for the bleeder resistor using the following formulas.

$$I = \text{leakage current in mA}$$

$$R = \frac{7.2}{2.4 \times I - 3} \text{ k}\Omega \text{ max.}$$

$$W = \frac{2.3}{R} \text{ W min.}$$

**Output Leakage Current**

If there is a possibility of leakage current causing a transistor or triac to malfunction, connect a bleeder resistor across the output as shown below.

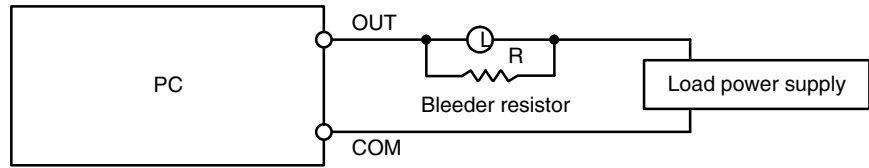

Determine the value and rating for the bleeder resistor using the following formula.

$$R < \frac{E_{on}}{I}$$

Where

$E_{on}$  = ON voltage of the load

$I$  = leakage current in mA

$R$  = bleeder resistance

**Output Surge Current**

When connecting a transistor or triac Output Unit to an output device having a high surge current (such as an incandescent lamp), care must be taken to avoid damage to the Output Unit. The transistor and triac Output Units are capable of withstanding a surge current of ten times the rated current. If the surge current for a particular device exceeds this amount, use the circuit shown below to protect the Output Unit.

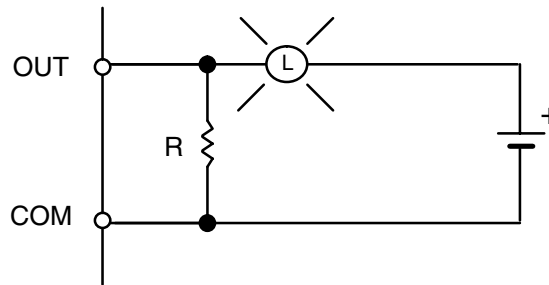

Another way of protecting the Output Unit lets the load draw a small current (about one third the rated current) while the output is OFF, significantly reducing the surge current. This circuit (shown below) not only reduces the surge current, but also reduces the voltage across the load at the same time.

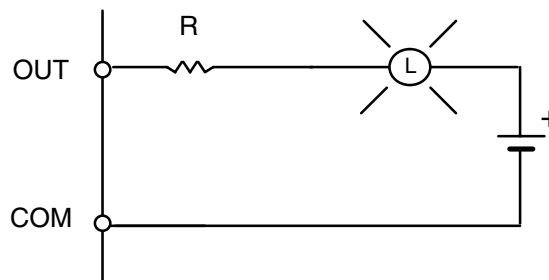

**Transistor Output Residual Voltage**

When connecting TTL circuits to transistor Output Units, it is necessary to connect a pull-up resistor and a CMOS IC between the two. This is because of the residual voltage left on the transistor output after the output turns OFF.

### Inductive Load Surge Suppressor

When an inductive load is connected to an I/O Unit, it is necessary to connect a surge suppressor or diode in parallel with the load as shown below. This is so that the back EMF generated by the load will be absorbed.

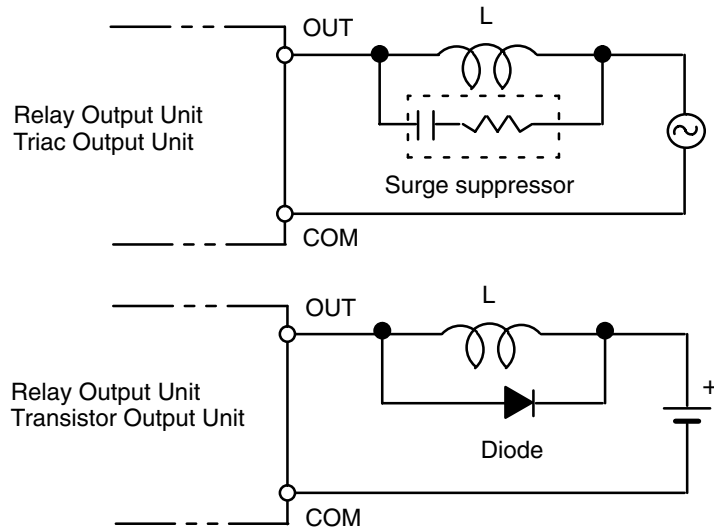

### Electrical Noise

Be sure to take appropriate measures when any electrical device likely to produce noise is connected to the PC as a load. Devices generating noise of more than 1,200 V (such as electromagnetic relays and valves) require noise suppression. For noise sources running off of AC power, connect a diode in parallel with the coil of each device.

When mounting a CPU Rack and an Expansion I/O Rack together on a mounting plate, be sure to provide a solid ground the mounting plate. The mounting plate must be plated with a highly conductive surface in order to ensure noise immunity.



# Appendix A

## Inspection and Maintenance

Certain consumable items in a PC (such as fuses, Relays, or batteries) need occasional replacement. This Appendix explains how to replace each of these items. Refer to *Appendix B* for the specifications of individual consumable items. Always keep spare items on hand so that they can be used as immediate replacements when needed.

### CPU and Power Supply Fuses

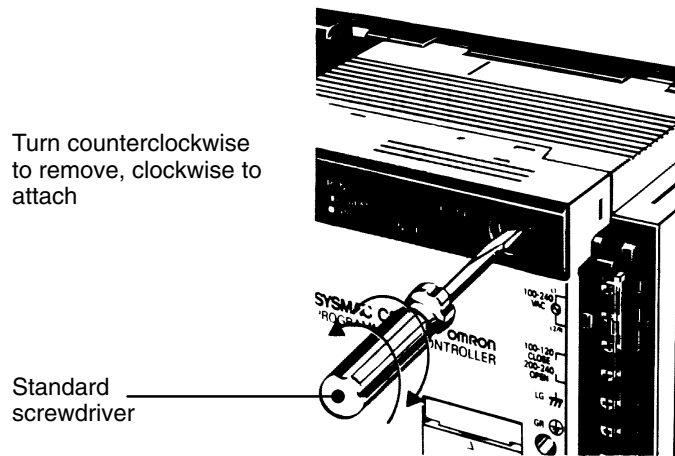

To replace a fuse, follow the steps below:

- 1, 2, 3...**
1. Turn OFF the power to the PC.
  2. Remove the fuse holder by turning it approximately 50° counterclockwise with a standard screwdriver.
  3. Remove the fuse from the holder.
  4. Insert a new fuse.
  5. Reattach the fuse holder by turning it approximately 50° clockwise with a standard screwdriver.

### Output Unit Fuses

To replace a fuse, follow the steps below. Use only UL/CSA certified replacement fuses.

#### Fuse Specifications (5.2-dia. x 20)

Model	F indicator (fuse blowout detection circuit)	Rating
C200H-OD411	Yes	5 A 125 V
C200H-OD211	No	
C200H-OD212	No	8 A 125 V
C200H-OD213	Yes	
C200H-OA121-E	Yes	5 A 125 V
C200H-OA122-E	Yes	
C200H-OA222V	No	3 A 250 V
C200H-OA223	Yes	5 A 250 V
C200H-OA224	No	3.15 A 250 V

- 1, 2, 3...**
1. Turn OFF the power to the PC.
  2. Detach the terminal block by unlocking the lock levers at the top and bottom of the terminal block.
  3. While pushing down the lock lever on the Backplane with a screwdriver as shown below, remove the Output Unit.

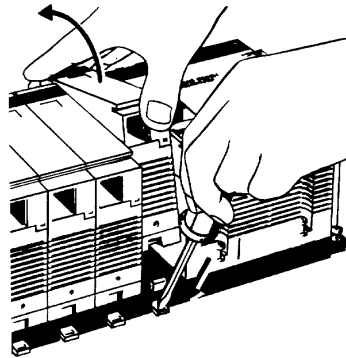

4. Remove the screw from the top of the Unit (Phillips screwdriver).
5. Detach the case from the Unit (flat-blade screwdriver).

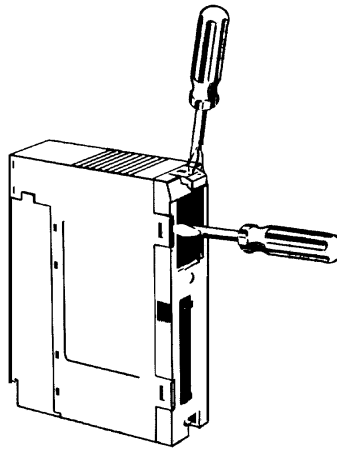

6. Pull out the printed circuit board.
7. Insert a new fuse. A spare fuse is provided inside the rear of the case when the Unit is delivered.
8. Reassemble in reverse order of assembly.

## Output Unit Relays

To replace a Relay, follow the steps below:

- 1, 2, 3...**
1. Turn OFF the power to the PC.
  2. Detach the terminal block by unlocking the lock levers at the top and bottom of the terminal block.

3. While pushing down the lock lever on the Backplane with a screwdriver as shown below, remove the Output Unit.

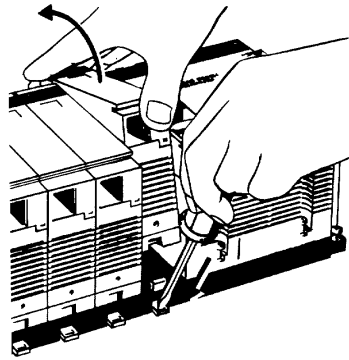

4. Remove the screw from the top of the Unit (Phillips screwdriver).
5. Detach the case from the Unit (flat-blade screwdriver).

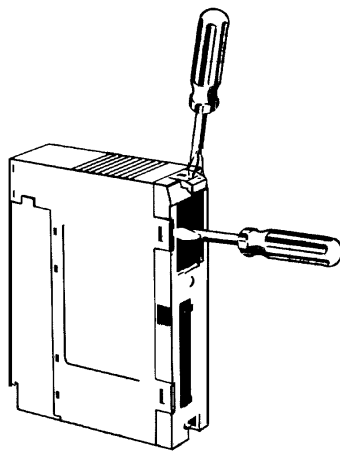

6. Pull out the printed circuit board. The Relays are placed on the PC boards of individual Units as shown in the figures below.

**OC221/OC224**

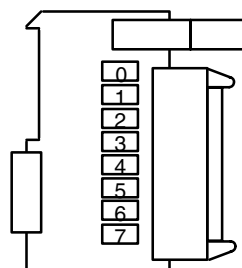

OC222

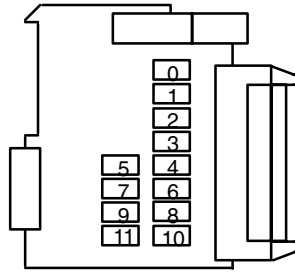

OC223

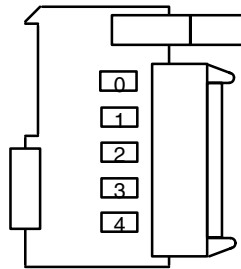

OC225

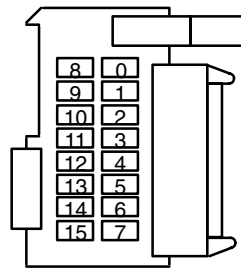

7. A Relay puller is provided inside the rear of the case when the Unit is delivered. Use the Relay puller to pull out the Relay as shown below. Insert a new Relay.

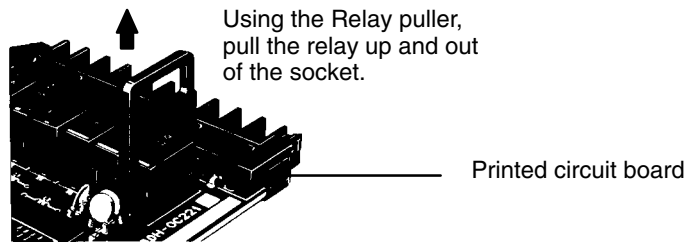

8. Reassemble in reverse order of assembly.

## Batteries

Some RAM Packs use a battery (refer to *Appendix B* for specifications). When the battery is nearly discharged, the ALARM indicator blinks and the message “BATT FAIL” appears on the Programming Console. When this occurs, replace the battery within one week to avoid loss of data. The battery comes together with its connector as a set. To replace the Battery Set, follow the steps below. The entire replacement must be completed within five minutes to ensure that the data will not be lost.

If you are using model C200H-CPU11-E as the CPU, the battery is installed in the Unit upon delivery.

- 1, 2, 3...**
1. Turn OFF the power to the PC. (If the power was not already ON, turn the power ON for at least one minute before turning the power OFF.)
  2. Remove the cover from the battery compartment of the RAM Pack.
  3. Remove the old Battery Set.
  4. Install the new Battery Set as shown shown in the following diagram.

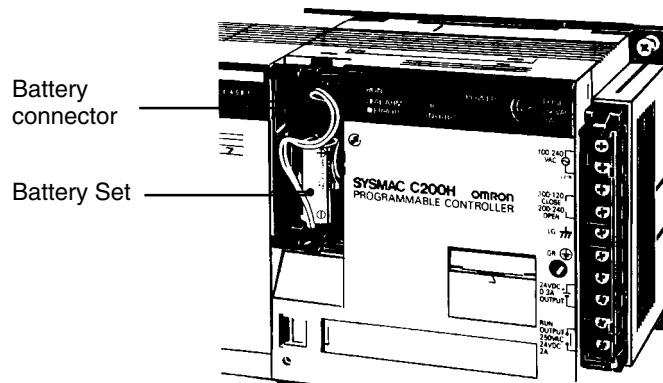

5. Replace the cover of the battery compartment.
6. Press CLR, FUN, MONTR, MONTR or just turn the power to the PC OFF and then ON again to clear the error message on the Programming Console.



# Appendix B Specifications

The following series of figures and tables provides a complete set of specifications for each Unit of the C200H. Note that I/O Units may take on one of three different shapes. Thus I/O Units are sometimes referred to as A-shape I/O Units, B-shape, or E-shape I/O Units. Refer to the figures at the end of the I/O Unit specifications for the exact dimensions of these three shapes of I/O Unit.

## General Specifications

Item	C200H-CPU01-E, CPU11-E/PS221	C200H-CPU03/PS211
Supply Voltage	100 to 120/200 to 240 VAC selectable 50/60 Hz	24 VDC
Operating Voltage Range	85 to 132/170 to 264 VAC	20.4 to 26.4 VDC
Power Consumption	120 VA max. per Rack (Backplane)	40 W max. per Rack (Backplane)
Surge Current	Approx. 5 times the normal current	
Output Capacity	CPU Rack: 3 A 5 VDC (1.6 A supplied to I/O Units) Refer to Section 4-4 Special Considerations for C200H-CPU11 Expansion I/O Unit Rack: 3 A 5 VDC (2.7 A supplied to I/O Units)	
Fuse	2 A 250 V 5.2 dia. x 20 (MF51NR)	2 A 125 V 5.2 dia. x 20 (MF51NR)
24 VDC Output	0.3 A 24 VDC +10%/-20%	None
Dielectric Strength	2,000 VAC 50/60 Hz for 1 minute between AC terminals and housing 500 VAC 50/60 Hz for 1 minute between DC terminals and housing leakage current: 10 mA max.	See <i>Caution</i> .
Noise Immunity	1,000 Vp-p, pulse width: 100 ns to 1 $\mu$ s, rise time: 1 ns	
Vibration	Mechanical durability: 10 to 35 Hz, 1 mm double amplitude (24.5 m/s <sup>2</sup> ) in X, Y, and Z directions, for 2 hours each (When mounted on DIN Rail, 16.7 Hz, 1 mm double amplitude (4.9 m/s <sup>2</sup> ) in X, Y, and Z directions, for 1 hour each) Malfunction durability: 2 to 55 Hz, 19.6 m/s <sup>2</sup> , in X, Y, and Z directions, for 20 minutes each (When mounted on DIN Rail, 2 to 55 Hz, 2.94 m/s <sup>2</sup> , in X, Y, and Z directions, for 20 minutes each)	
Shock	98 m/s <sup>2</sup> in X, Y, and Z directions, 3 times each	
Ambient Temperature	Operating: 0° to 55°C (0° to 45°C for Programming Console) Storage: -20° to 65°C	
Humidity	35 to 85% RH (without condensation)	
Atmosphere	Must be free of the following: <ul style="list-style-type: none"> <li>• Corrosive gases</li> <li>• Abrupt temperature changes</li> <li>• Direct sunlight</li> <li>• Dust, salt, or metal filings</li> <li>• Water, oil, or chemicals</li> </ul>	
Grounding	Less than 100 $\Omega$	
Degree of Protection	Mounted in a panel	
Weight	6 kg max.	



### Caution

When conducting an insulation resistance or dielectric strength test, disconnect the power supply terminals from the LG and GR terminals. Do not conduct a dielectric strength test on the C200H-CPU03-E, PS211, RT002-P, or RT202 Units. The power supply input line and internal circuit of the 24 VDC Power Supply are not isolated from each other. If a dielectric strength test is conducted, the Power Supply will be damaged.

## CPU Specifications

Main Control Element	MPU, CMOS, LS-TTL			
Programming Method	Ladder diagram			
Instruction Length	1 address/instruction, 1 to 4 words/instruction			
Number of Instructions	145 (12 basic instructions + 133 special instructions) C200H-CPU11 159 (12 basic instructions + 147 special instructions)			
Execution Time	Basic instructions: 0.75 to 2.25 $\mu$ s		Special instructions: 34 to 724 $\mu$ s	
Memory Capacity	6,974 words (with 8k-word memory)			
I/O bits	480 (00000 through 02915)	I/O Units mounted to Remote I/O Slave	Special I/O Units 1,600	Optical I/O Units and I/O Terminals 512
IR bits	3,296 (03000 through 23515)	Racks 800 (05000 through 09915)	(10000 through 19915)	(20000 through 23115)
SR bits	312 (23600 through 25507)			
TR bits	8 (TR 0 through 7)			
HR bits	1,600 (HR 0000 through 9915)			
AR bits	448 (AR 0000 through 2715)			
LR bits	1,024 (LR 0000 through 6315)			
Timers/Counters	512 (TIM/CNT 000 through 511) TIMHs: 0 through 99.99 s		TIMs: 0 through 999.9 s CNT: 0 through 9999 counts	
DM words	Read/write: 1,000 (DM 0000 through 0999) Read only: 1,000 (DM 1000 through 1999)		DM area is in Memory Pack.	
RUN Output	Contacts are closed while PC is in RUN mode and operating. Max. switching capacity: 2A 250 VAC (resistive load) 0.5 A 250 VAC (inductive load, cos of phase angle = 0.4) 2 A 24 VDC			
Memory Protection	Status of HR bits, AR bits, preset value of counters (CNT), and contents of data memory (DM) are retained during power failure. Length of memory protection depends on the Memory Pack model being used (refer to <i>Section 2-6 Memory Packs</i> ).			
Self-diagnostic Functions	CPU failure (watchdog timer) Cycle time error I/O bus failure Remote I/O error, etc.		Battery failure Memory failure Host Link error	
Program Check	Program check (executed on start of RUN operation): END missing Instruction errors (Program can be checked by Programming Console or GPC at three levels.)			



### AC Input Unit C200H-IA121

Rated Input Voltage	100 to 120 VAC 50/60 Hz
Operating Input Voltage	85 to 132 VAC 50/60 Hz
Input Impedance	9.7 kΩ (50 Hz), 8 kΩ (60 Hz)
Input Current	10 mA typical (at 100 VAC)
ON Voltage	60 VAC min.
OFF Voltage	20 VAC max.
ON Response Time	35 ms max. (at 100 VAC, 25°C)
OFF Response Time	55 ms max. (at 100 VAC, 25°C)
No. of Circuits	1 (8 points/common)
Internal Current Consumption	10 mA 5 VDC max.
Weight	250 g max.
Dimensions	A-shape

### Circuit Configuration

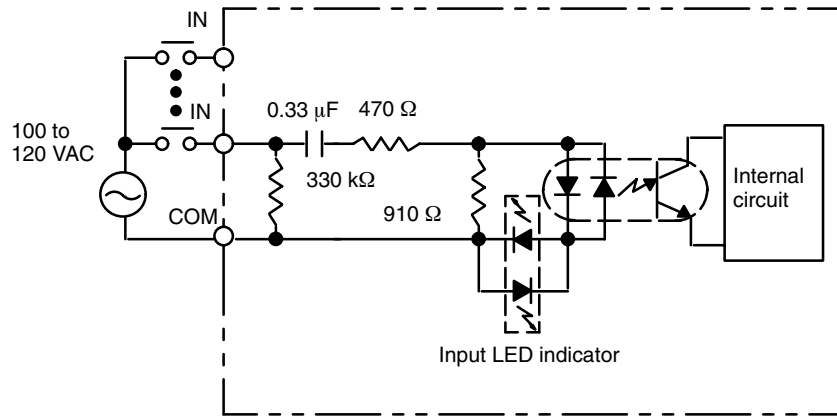

### Terminal Connections

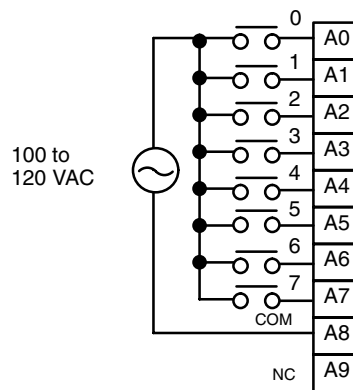

### AC Input Unit C200H-IA122/IA122V

Rated Input Voltage	100 to 120 VAC 50/60 Hz
Operating Input Voltage	85 to 132 VAC 50/60 Hz
Input Impedance	9.7 kΩ (50 Hz), 8 kΩ (60 Hz)
Input Current	10 mA typical (at 100 VAC)
ON Voltage	60 VAC min.
OFF Voltage	20 VAC max.
ON Response Time	35 ms max. (at 100 VAC, 25°C)
OFF Response Time	55 ms max. (at 100 VAC, 25°C)
No. of Circuits	1 (16 points/common)
Internal Current Consumption	10 mA 5 VDC max.
Weight	IA122: 300 g max. IA122V: 400 g max.
Dimensions	B-shape

### Circuit Configuration

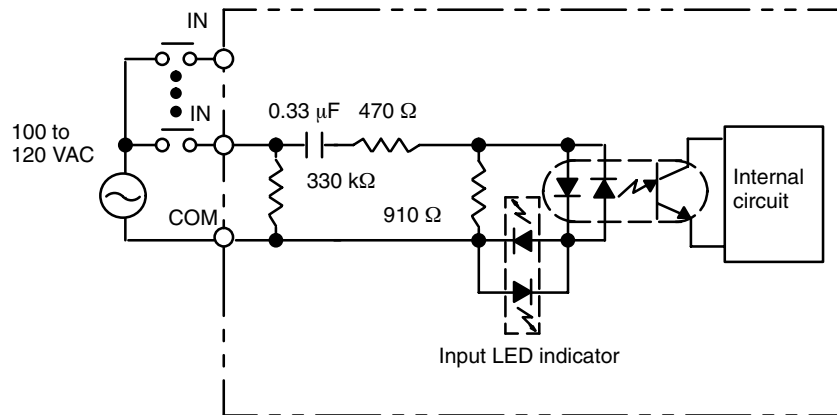

### Terminal Connections

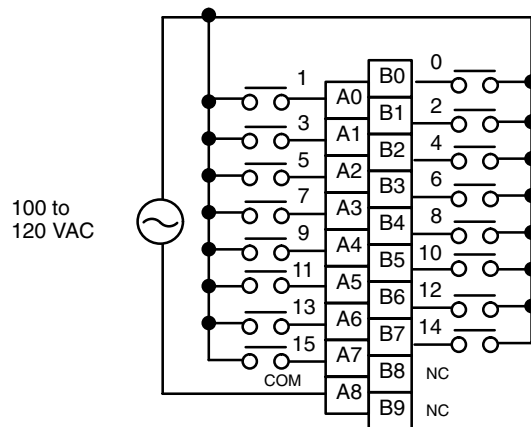

### AC Input Unit C200H-IA221

Rated Input Voltage	200 to 240 VAC 50/60 Hz
Operating Input Voltage	170 to 264 VAC 50/60 Hz
Input Impedance	21 kΩ (50 Hz), 18 kΩ (60 Hz)
Input Current	10 mA typical (at 200 VAC)
ON Voltage	120 VAC min.
OFF Voltage	40 VAC max.
ON Response Time	35 ms max. (at 200 VAC, 25°C)
OFF Response Time	55 ms max. (at 200 VAC, 25°C)
No. of Circuits	1 (8 points/common)
Internal Current Consumption	10 mA 5 VDC max.
Weight	250 g max.
Dimensions	A-shape

### Circuit Configuration

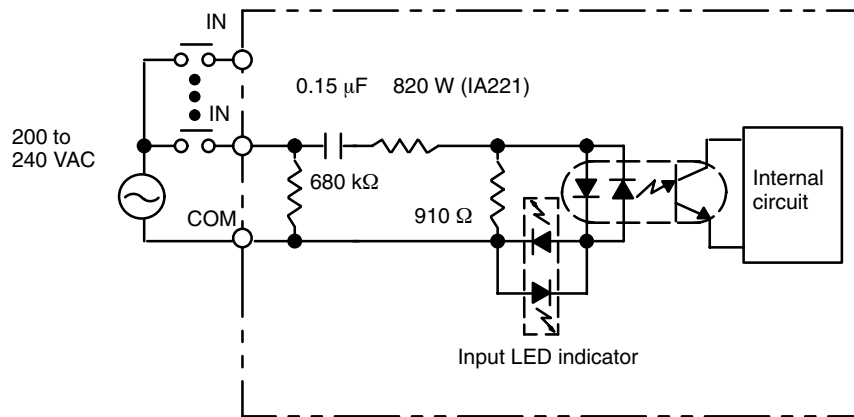

### Terminal Connections

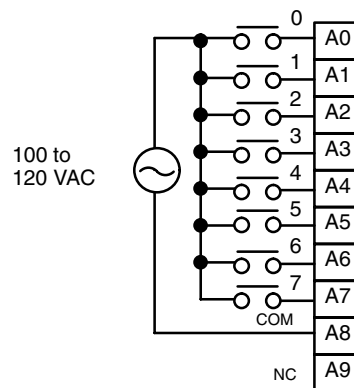

### AC Input Unit C200H-IA222/IA222V

Rated Input Voltage	200 to 240 VAC 50/60 Hz
Operating Input Voltage	170 to 264 VAC 50/60 Hz
Input Impedance	21 kΩ (50 Hz), 18 kΩ (60 Hz)
Input Current	10 mA typical (at 200 VAC)
ON Voltage	120 VAC min.
OFF Voltage	40 VAC max.
ON Response Time	35 ms max. (at 200 VAC, 25°C)
OFF Response Time	55 ms max. (at 200 VAC, 25°C)
No. of Circuits	1 (16 points/common)
Internal Current Consumption	10 mA 5 VDC max.
Weight	IA222: 300 g max. IA222V: 400 g max.
Dimensions	B-shape

### Circuit Configuration

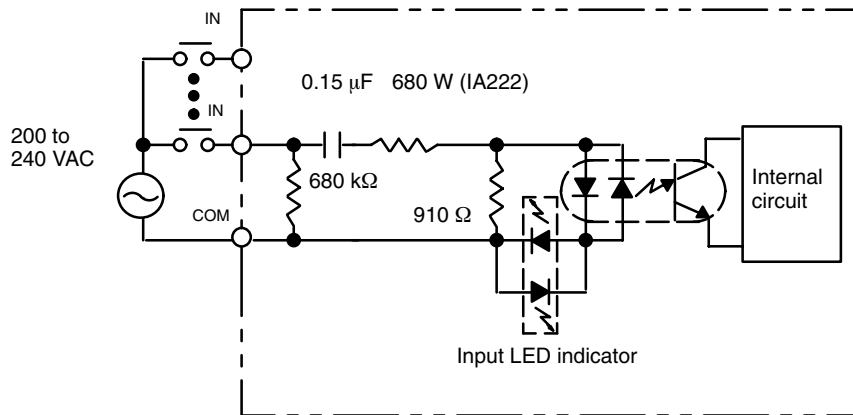

### Terminal Connections

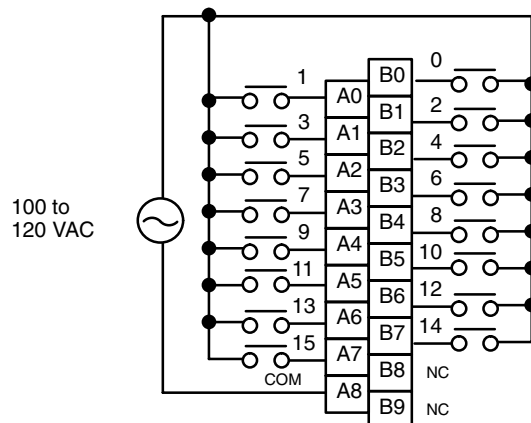

### No-Voltage Contact Input Unit C200H-ID001

Input Voltage	No-voltage contact/NPN output type (negative common)
Input Impedance	3 kΩ
Input Current	7 mA typical
ON Voltage	(14.4 VDC min.)
OFF Voltage	(5.0 VDC max.)
ON Response Time	1.5 ms max. (no-voltage contact, at 25°C)
OFF Response Time	1.5 ms max. (no-voltage contact, at 25°C)
No. of Circuits	1 (8 points/common)
Internal Current Consumption	10 mA 5 VDC max.
Weight	200 g max.
Dimensions	A-shape

### Circuit Configuration

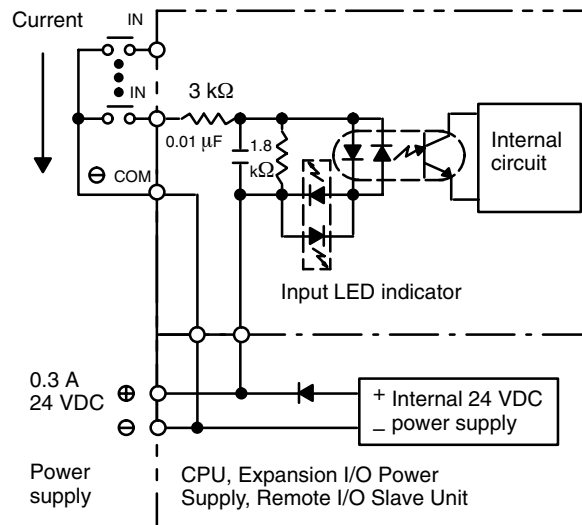

**Note** The power is supplied to the Input Units from the 24 VDC output of the Power Supply of the CPU, Expansion I/O Unit, or Remote I/O Unit. Never connect 24 VDC output terminals to the input terminals or COM terminals.

### Terminal Connections

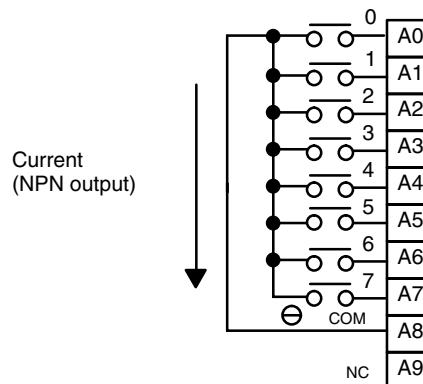

### No-Voltage Contact Input Unit C200H-ID002

Input Voltage	No-voltage contact/NPN output type (positive common)
Input Impedance	3 kΩ
Input Current	7 mA typical
ON Voltage	(14.4 VDC min.)
OFF Voltage	(5.0 VDC max.)
ON Response Time	1.5 ms max. (no-voltage contact, at 25°C)
OFF Response Time	1.5 ms max. (no-voltage contact, at 25°C)
No. of Circuits	1 (8 points/common)
Internal Current Consumption	10 mA 5 VDC max.
Weight	200 g max.
Dimensions	A-shape

### Circuit Configuration

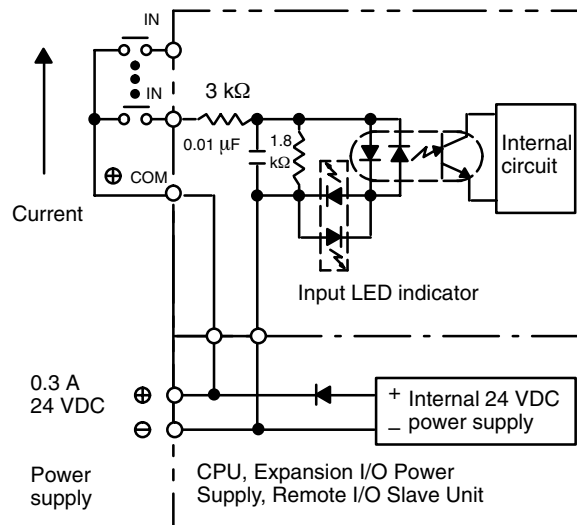

**Note** The power is supplied to the Input Units from the 24 VDC output of the Power Supply of the CPU, Expansion I/O Unit, or Remote I/O Unit. Never connect 24 VDC output terminals to the input terminals or COM terminals.

### Terminal Connections

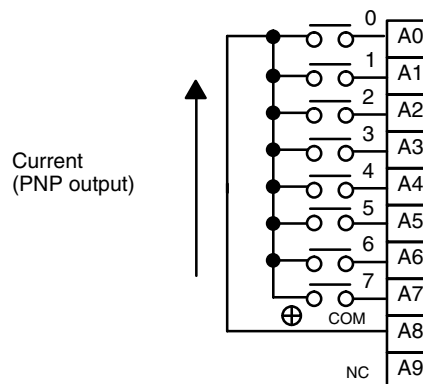

### DC Input Unit C200H-ID211

Rated Input Voltage	12 to 24 VDC
Operating Input Voltage	10.2 to 26.4 VDC
Input Impedance	2 kΩ
Input Current	10 mA (at 24 VDC)
ON Voltage	10.2 VDC min.
OFF Voltage	3.0 VDC max.
ON Response Time	1.5 ms max. (at 24 VDC, 25°C)
OFF Response Time	1.5 ms max. (at 24 VDC, 25°C)
No. of Circuits	1 (8 point/common)
Internal Current Consumption	10 mA 5 VDC max.
Weight	200 g max.
Dimensions	A-shape

### Circuit Configuration

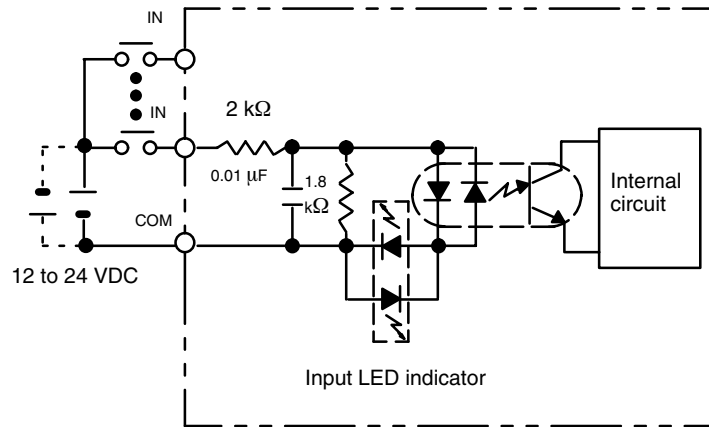

### Terminal Connections

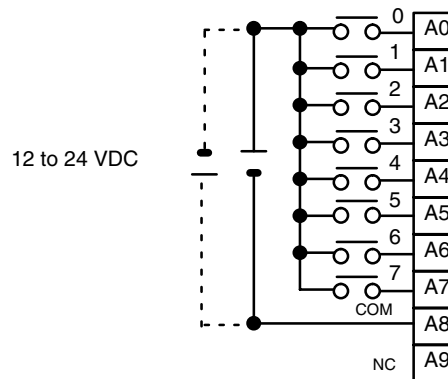

### DC Input Unit C200H-ID212

Rated Input Voltage	24 VDC
Operating Input Voltage	20.4 to 26.4 VDC
Input Impedance	3 kΩ
Input Current	7 mA (at 24 VDC)
ON Voltage	14.4 VDC min.
OFF Voltage	5.0 VDC max.
ON Response Time	1.5 ms max. (at 24 VDC, 25°C)
OFF Response Time	1.5 ms max. (at 24 VDC, 25°C)
No. of Circuits	1 (16 points/common)
Internal Current Consumption	10 mA 5 VDC max.
Weight	300 g max.
Dimensions	B-shape

### Circuit Configuration

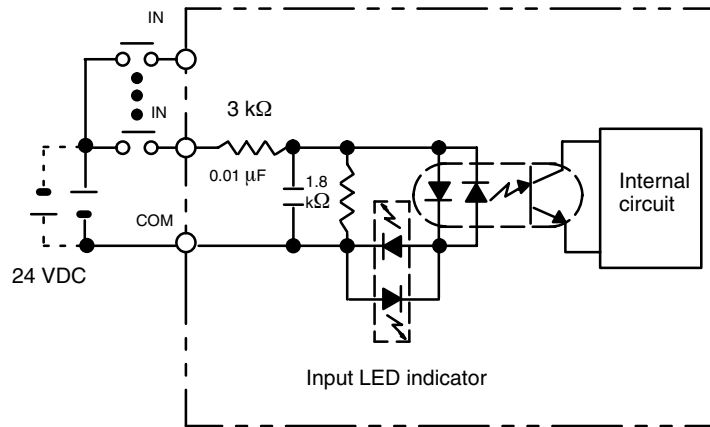

### Terminal Connections

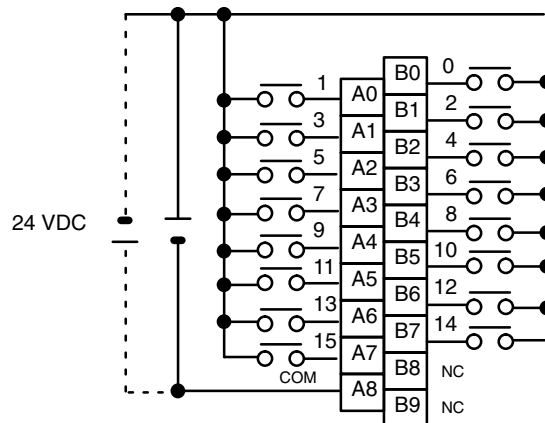



### AC/DC Input Unit C200H-IM211

Rated Input Voltage	12 to 24 VDC
Operating Input Voltage	10.2 to 26.4 VDC
Input Impedance	2 kΩ
Input Current	10 mA typical (at 24 VDC)
ON Voltage	10.2 VDC min.
OFF Voltage	3.0 VDC max.
ON Response Time	15 ms max. (at 24 VDC, 25°C)
OFF Response Time	15 ms max. (at 24 VDC, 25°C)
No. of Circuits	1 (8 points/common)
Internal Current Consumption	10 mA 5 VDC max.
Weight	200 g max.
Dimensions	A-shape

### Circuit Configuration

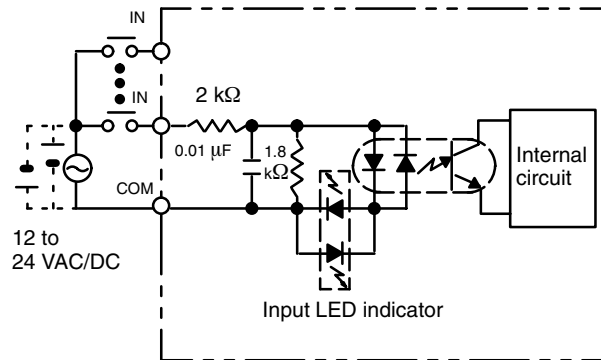

### Terminal Connections

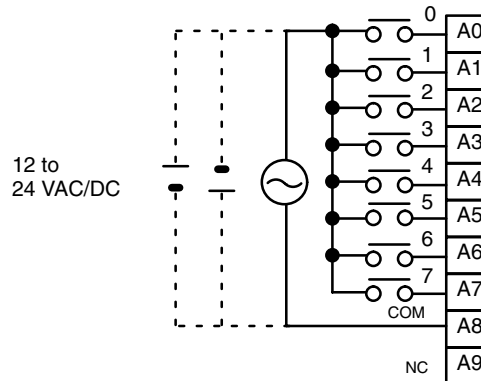

### AC/DC Input Unit C200H-IM212

Rated Input Voltage	24 VDC
Operating Input Voltage	20.4 to 26.4 VDC
Input Impedance	3 kΩ
Input Current	7 mA typical (at 24 VDC)
ON Voltage	14.4 VDC min.
OFF Voltage	5.0 VDC max.
ON Response Time	1.5 ms max. (at 24 VDC, 25°C)
OFF Response Time	1.5 ms max. (at 24 VDC, 25°C)
No. of Circuits	1 (16 points/common)
Internal Current Consumption	10 mA 5 VDC max.
Weight	250 g max.
Dimensions	B-shape

### Circuit Configuration

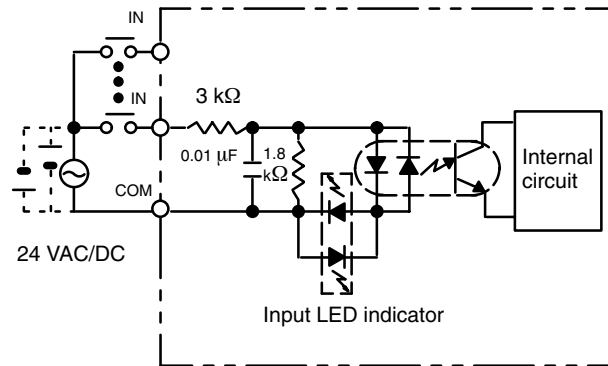

### Terminal Connections

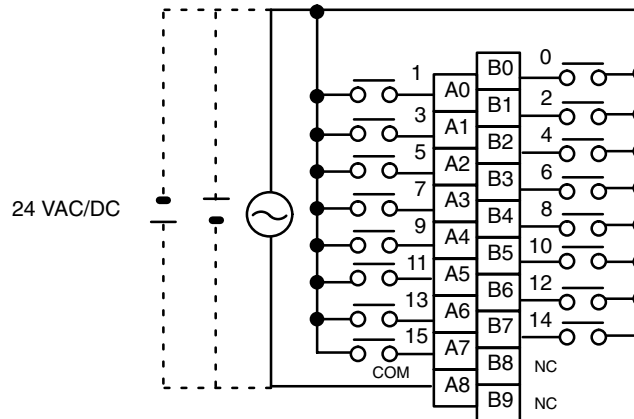

### Triac Output Unit C200H-OA222V

Max. Switching Capacity	0.3 A 250 VAC, 50/60 Hz (2 A/Unit)
Min. Switching Capacity	10 mA (resistive load)/40 mA (inductive load) 10 VAC
Leakage Current	3 mA (100 VAC) max./6 mA (200 VAC) max.
Residual Voltage	1.2 V max.
ON Response Time	1/2 of load frequency or less.
OFF Response Time	1/2 of load frequency or less.
No. of Circuits	1 (12 points/common)
Internal Current Consumption	200 mA 5 VDC max.
Fuse Rating	3 A 250 V (5.2-dia.x20)
Power for External Supply	N/A
Weight	400 g max.
Dimensions	B-shape

### Circuit Configuration

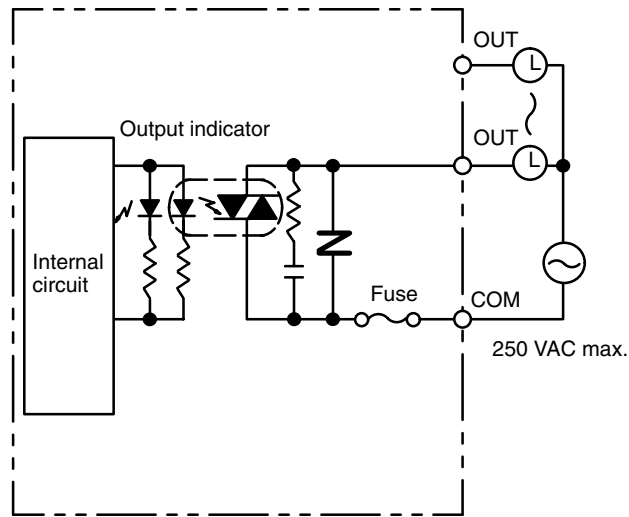

Fuse: 3 A 250 V (5.2-dia.x20) MF51SH (JIS)

**Note** No blown fuse detector circuit is provided.

### Terminal Connections

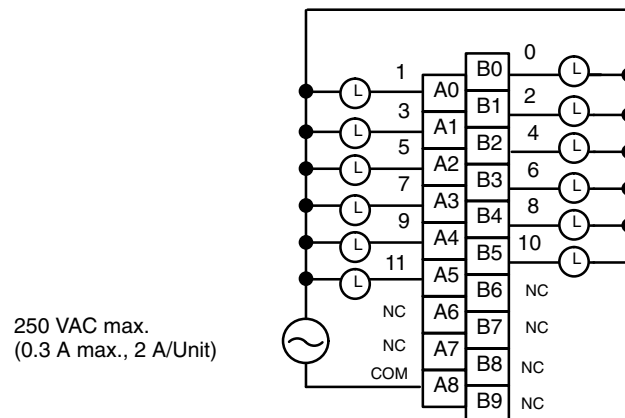

250 VAC max.  
(0.3 A max., 2 A/Unit)

### Triac Output Unit C200H-OA121-E

Max. switching capacity	1 A 120 VAC, 50/60 Hz (4 A/Unit)
Min. switching capacity	10 mA (resistive load)/40 mA (inductive load) 10 VAC
Leakage Current	3 mA (100 VAC) max.
Residual Voltage	1.2 V max.
ON Response Time	1 ms max.
OFF Response Time	1/2 of load frequency or less.
No. of Circuits	1 (8 points/common)
Internal Current Consumption	140 mA 5 VDC max.
Fuse Rating	5 A 125 V (5.2-dia.x20)
Power for External Supply	N/A
Weight	250 g max.
Dimensions	A-shape

### Circuit Configuration

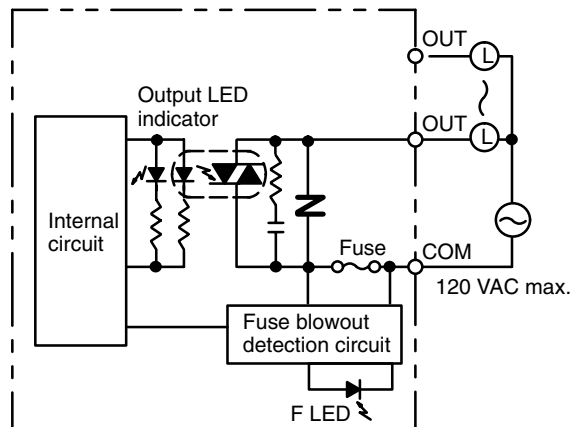

Fuse: 5 A 125 V (5.2-dia.x20) GGS (Nagasawa)

**Note** When the fuse blows F LED lights and bit 08 turns ON. Bits 08 through 15 cannot be used as work bits.

### Terminal Connections

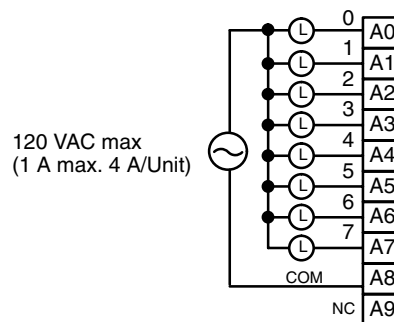

### Triac Output Unit C200H-OA122-E

Max. Switching Capacity	1.2 A 120 VAC, 50/60 Hz (4 A/Unit)
Max. Inrush Current	15 A (pulse width: 100 ms) 30 A (pulse width: 10 ms)
Min. Switching Capacity	100 mA 10 VAC/50 mA 24 VAC/10 mA 100 VAC min.
Leakage Current	1.5 mA (120 VAC) max.
Residual Voltage	1.5 VAC max. (50 to 1,200 mA)/ 5 VAC max. (10 to 50 mA)
ON Response Time	1 ms max.
OFF Response Time	1/2 of load frequency+1 ms or less.
No. of Circuits	1 (8 points/common)
Internal Current Consumption	180 mA 5 VDC max.
Fuse Rating	5 A 125 V (5.2-dia.x20)
Power for External Supply	N/A
Weight	300 g max.
Dimensions	E-shape

### Circuit Configuration

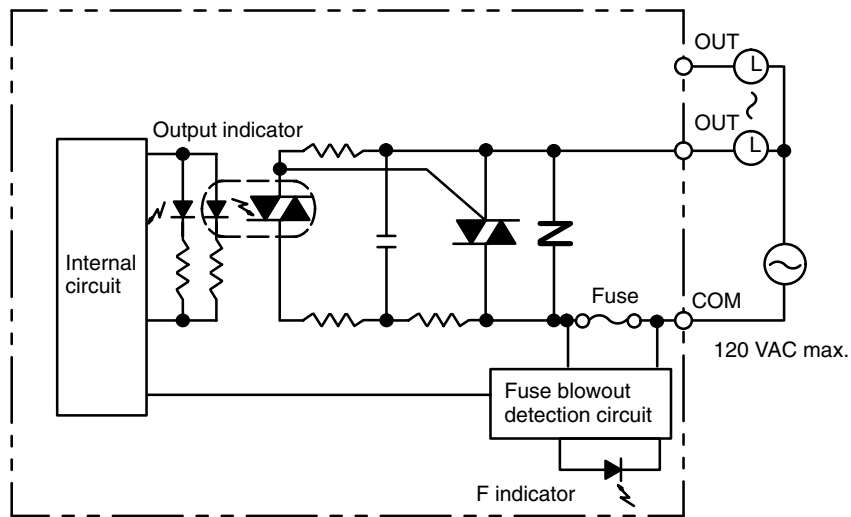

Fuse: 5 A 125 V (5.2-dia.x20) GGS (Nagasawa)

**Note** When the fuse blows, the F indicator lights and bit 08 turns ON. Bits 08 through 15 cannot be used as work bits.

### Terminal Connections

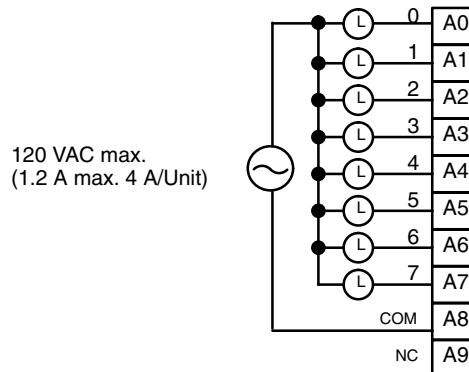

### Triac Output Unit C200H-OA223

Max. Switching Capacity	1.2 A 250 VAC, 50/60 Hz (4 A/Unit)
Max. Inrush Current	15 A (pulse width: 100 ms) 30 A (pulse width: 10 ms)
Min. Switching Capacity	100 mA 10 VAC/50 mA 24 VAC/10 mA 100 VAC min.
Leakage Current	1.5 mA (120 VAC) max./3 mA (240 VAC) max.
Residual Voltage	1.5 VAC max. (50 to 1,200 mA)/ 5 VAC max. (10 to 50 mA)
ON Response Time	1 ms max.
OFF Response Time	1/2 of load frequency+ 1 ms or less.
No. of Circuits	1 (8 points/common)
Internal Current Consumption	180 mA 5 VDC max.
Fuse Rating	5 A 250 V (5.2-dia.x20)
Power for External Supply	N/A
Weight	300 g max.
Dimensions	E-shape

### Circuit Configuration

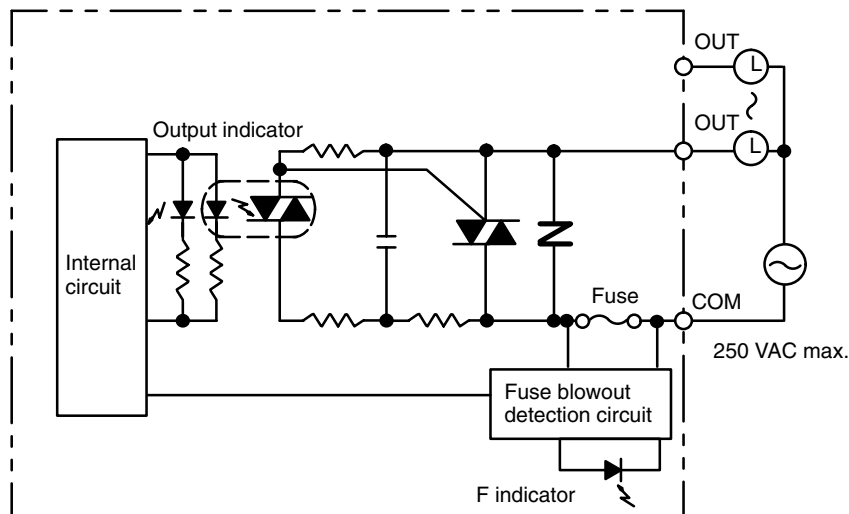

Fuse: 5 A 250 V (5.2-dia.x20) HT (SOC)

**Note** When the fuse blows F LED lights and bit 08 turns ON. Bits 08 through 15 cannot be used as work bits.

### Terminal Connections

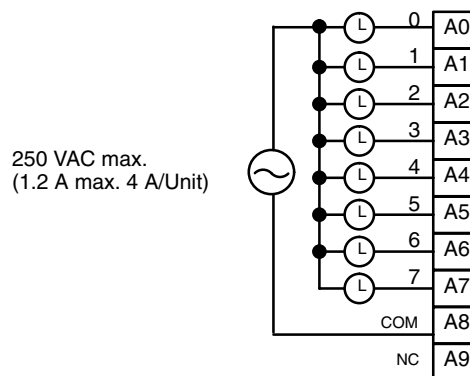

### Triac Output Unit C200H-OA224

Max. Switching Capacity	0.5 A 250 VAC, 50/60 Hz (2 A/Unit)
Max. Inrush Current	10 A (pulse width: 100ms) 20 A (pulse width: 10 ms)
Min. Switching Capacity	100 mA 10 VAC/50 mA 24 VAC/10 mA 100 VAC min.
Leakage Current	1.5 mA (120 VAC) max./3 mA (240 VAC) max.
Residual Voltage	1.5 VAC max. (50 to 500 mA)/5 VAC max. (10 to 50 mA)
ON Response Time	1 ms max.
OFF Response Time	1/2 of load frequency + 1 ms or less.
No. of Circuits	1 (12 points/common)
Internal Current Consumption	270 mA 5 VDC max.
Fuse Rating	3.15 A 250 V (5.2-dia.x20)
Power for External Supply	N/A
Weight	300 g max.
Dimensions	B-shape

### Circuit Configuration

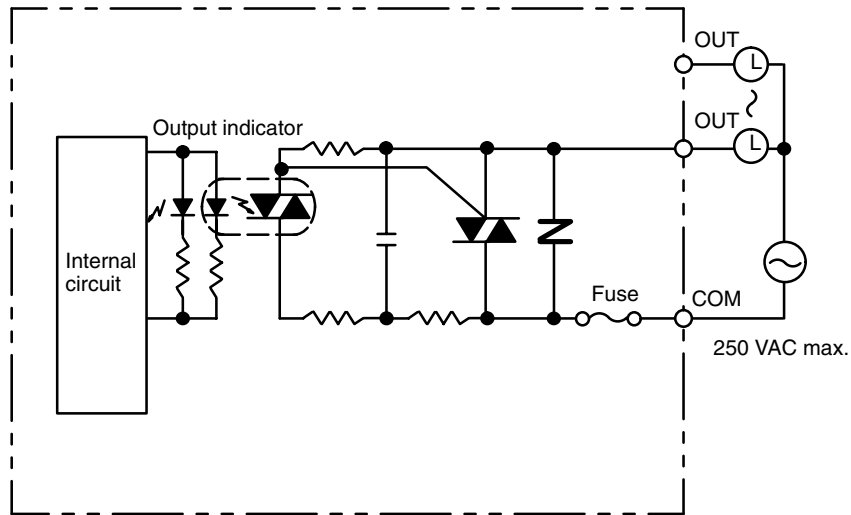

Fuse: 3.15 A 250 V (5.2-dia.x20) MT4 (SOC)

- Note**
1. No blown fuse detector circuit is provided.
  2. Check the fuse when there is no output.

### Terminal Connections

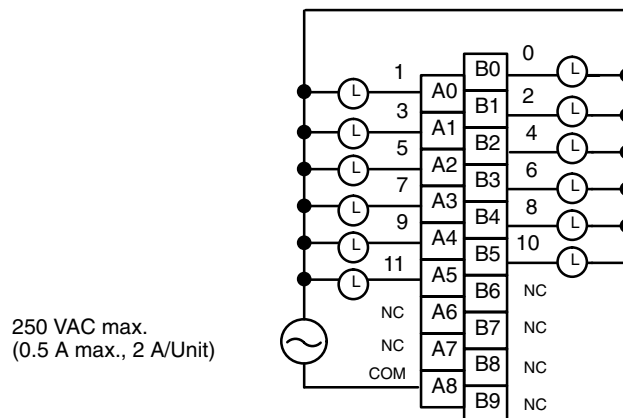

250 VAC max.  
(0.5 A max., 2 A/Unit)

### Contact Output Unit C200H-OC221

Max. switching capacity	2 A 250 VAC (cos of phase angle = 1), 2 A 250 VAC (cos of phase angle = 0.4), 2 A 24 VDC 8 A/Unit
Min. switching capacity	10 mA 5 VDC
Relay	G6B-1174P-FD-US (24 VDC) w/socket
Service Life of Relay	Electrical: 500,000 operations (resistive load)/ 100,000 operations (inductive load) Mechanical: 50,000,000 operations
ON Response Time	10 ms max.
OFF Response Time	10 ms max.
No. of Circuits	1 (8 points/common)
Internal Current Consumption	10 mA 5 VDC max. 75 mA 25 VDC (8 points ON simultaneously.)
Weight	250 g max.
Dimensions	A-shape

### Circuit Configuration

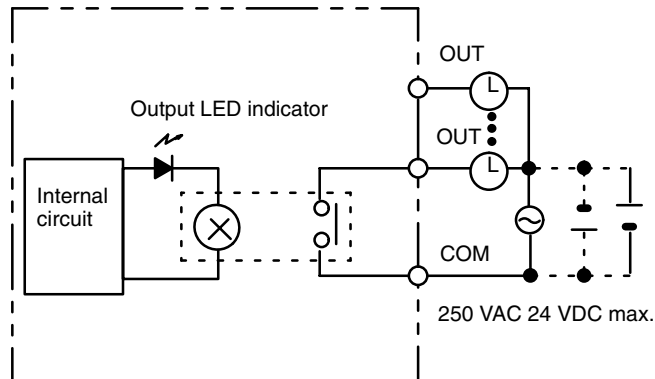

### Terminal Connections

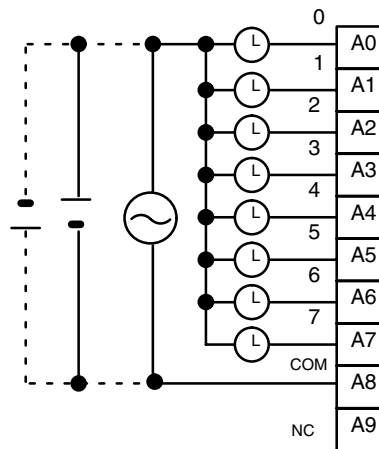

250 VAC 24 VDC max.  
(inductive load: 2 A resistive load: 2 A) (8 A/Unit)



### Contact Output Unit C200H-OC222

Max. switching capacity	2 A 250 VAC (cos of phase angle = 1), 2 A 250 VAC (cos of phase angle = 0.4), 2 A 24 VDC 8 A/Unit
Min. switching capacity	10 mA 5 VDC
Relay	G6B-1174P-FD-US (24 VDC) w/socket
Service Life of Relay	Electrical: 500,000 operations (resistive load)/ 100,000 operations (inductive load) Mechanical: 50,000,000 operations
ON Response Time	10 ms max.
OFF Response Time	10 ms max.
No. of Circuits	1 (12 points/common) 8 points max. can be ON simultaneously.
Internal Current Consumption	10 mA 5 VDC max. 75 mA 25 VDC (8 points ON simultaneously.)
Weight	300 g max.
Dimensions	B-shape

### Circuit Configuration

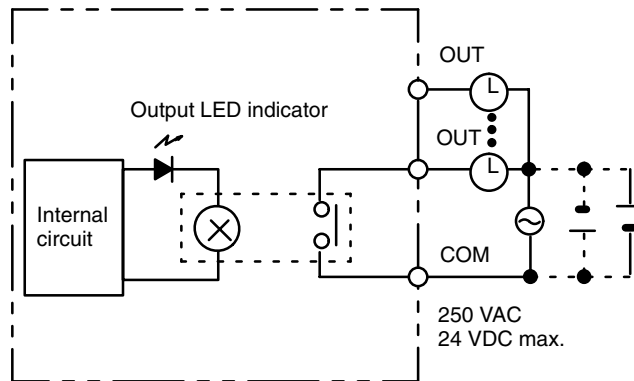

### Terminal Connections

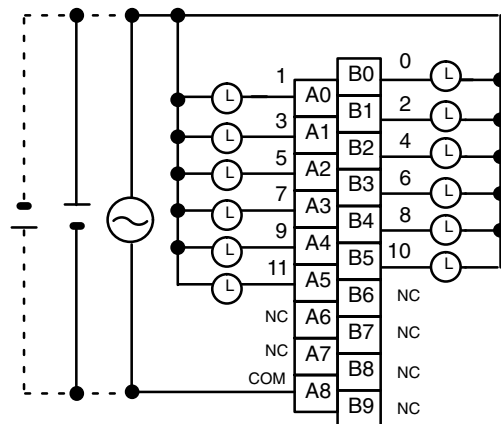

250 VAC 24 VDC max.  
(inductive load: 2 A resistive load: 2 A) (8 A/Unit)

### Contact Output Unit C200H-OC223

Max. switching capacity	2 A 250 VAC (cos of phase angle = 1), 2 A 250 VAC (cos of phase angle = 0.4), 2 A 24 VDC 10 A/Unit
Min. switching capacity relay	10 mA 5 VDC
Service Life of Relay	Electrical: 500,000 operations (resistive load)/ 100,000 operations (inductive load) Mechanical: 50,000,000 operations
ON Response Time	10 ms max.
OFF Response Time	10 ms max.
No. of Circuits	5 independent contacts
Internal Current Consumption	10 mA 5 VDC max. 75 mA 25 VDC (8 points ON simultaneously.)
Weight	250 g max.
Dimensions	A-shape

### Circuit Configuration

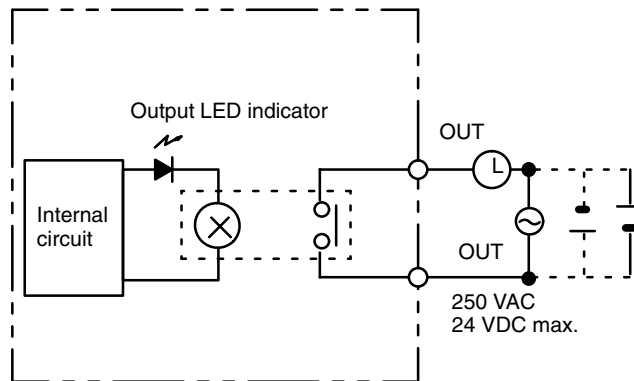

### Terminal Connections

250VAC 24 VDC max.  
(inductive load: 2 A  
resistive load: 2 A)  
(8 A/Unit)

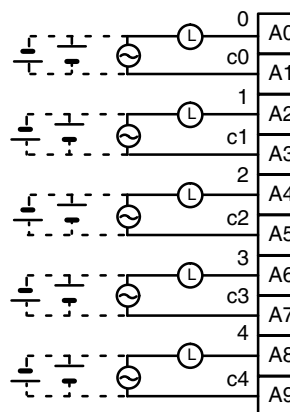

### Contact Output Unit C200H-OC224

Max. switching capacity	2 A 250 VAC (cos of phase angle = 1), 2 A 250 VAC (cos of phase angle = 0.4), 2 A 24 VDC 16 A/Unit
Min. switching capacity relay	10 mA 5 VDC
Service Life of Relay	Electrical: 500,000 operations (resistive load)/ 100,000 operations (inductive load) Mechanical: 50,000,000 operations
ON Response Time	10 ms max.
OFF Response Time	10 ms max.
No. of Circuits	8 independent contacts
Internal Current Consumption	10 mA 5 VDC max. 75 mA 25 VDC (8 points ON simultaneously.)
Weight	300 g max.
Dimensions	B-shape

### Circuit Configuration

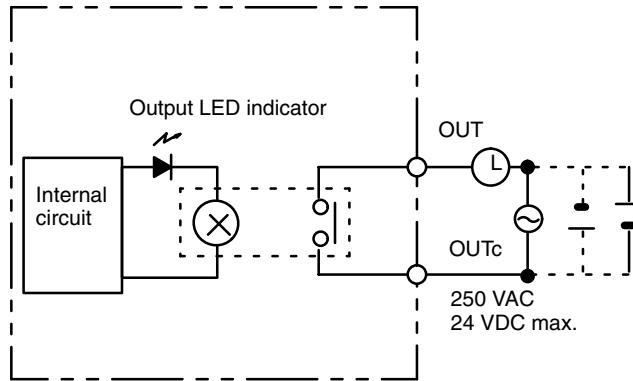

### Terminal Connections

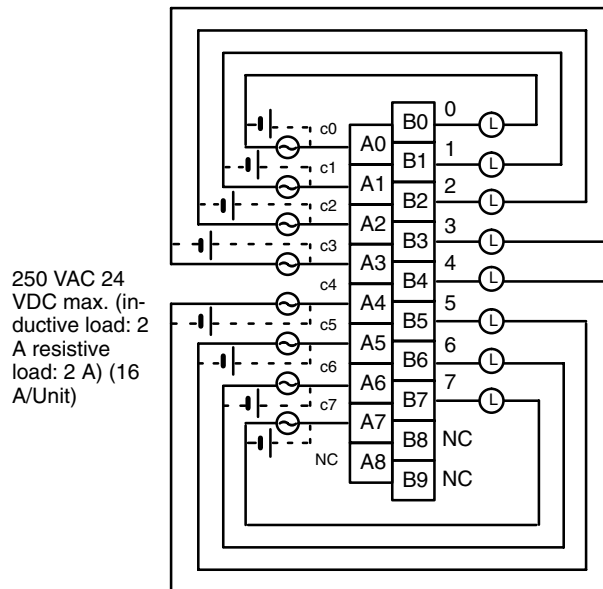

### Contact Output Unit C200H-OC225

Max. switching capacity	2 A 250 VAC (cos of phase angle = 1), 2 A 250 VAC (cos of phase angle = 0.4), 2 A 24 VDC 8 A/Unit
Min. switching capacity	10 mA 5 VDC
Relay	G6B-1174P-FD-US (24 VDC) w/socket
Service Life of Relay	Electrical: 500,000 operations (resistive load)/ 100,000 operations (inductive load) Mechanical: 50,000,000 operations
ON Response Time	10 ms max.
OFF Response Time	10 ms max.
No. of Circuits	1 (16 points/common) 8 points max. can be ON simultaneously.
Internal Current Consumption	50 mA 5 VDC max. 75 mA 25 VDC (8 points ON simultaneously.)
Weight	400 g max.
Dimensions	B-shape

### Circuit Configuration

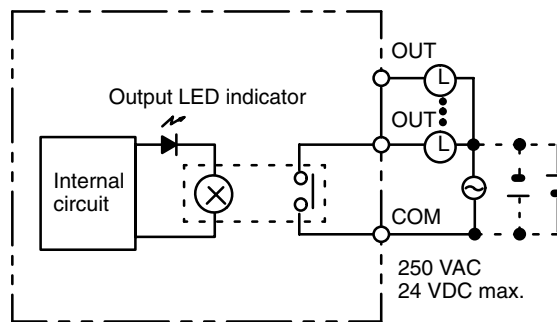

### Terminal Connections

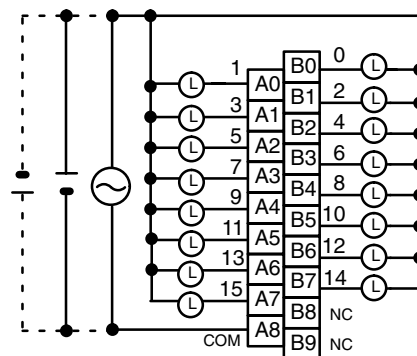

250 VAC 24 VDC max.  
(inductive load: 2 A resistive load: 2 A) (8 A/Unit)

**Note** This Unit must be mounted to a C200H-BC□□1-V1/V2 Backplane.

### Transistor Output Unit C200H-OD211

Max. switching capacity	0.3 A 24 VDC $+10\%/_{-15\%}$ (2 A/Unit)
Min. switching capacity	None
Leakage Current	0.1 mA max.
Residual Voltage	1.4 V max.
ON Response Time	0.2 ms max.
OFF Response Time	0.3 ms max.
No. of Circuits	1 (12 points/common)
Internal Current Consumption	160 mA 5 VDC max.
Fuse Rating	5 A 125 V (5.2-dia.x20)
Power for External Supply	25 mA 24 VDC $+10\%/_{-15\%}$ max.
Weight	300 g max.
Dimensions	B-shape

### Circuit Configuration

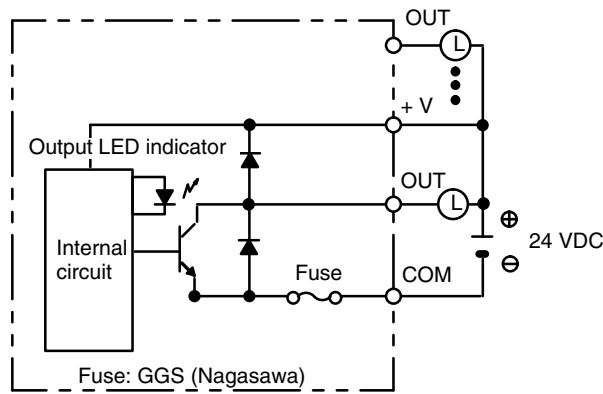

**Note** No blown fuse detector circuit is provided.

### Terminal Connections

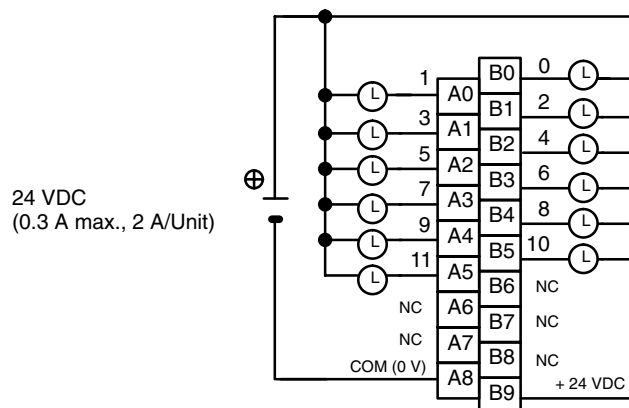

**Note** Be sure to supply power to B9; otherwise current will leak through the load while the output is OFF.

### Transistor Output Unit C200H-OD212

Max. switching capacity	0.3 A 24 VDC <sup>+10%</sup> / <sub>-15%</sub> (4.8 A/Unit)
Min. switching capacity	None
Leakage Current	0.1 mA max.
Residual Voltage	1.4 V max.
ON Response Time	0.2 ms max.
OFF Response Time	0.3 ms max.
No. of Circuits	1 (16 points/common)
Internal Current Consumption	180 mA 5 VDC max.
Fuse Rating	8 A 125 V (5.2-dia.x20)
Power for External Supply	35 mA 24 VDC <sup>+10%</sup> / <sub>-15%</sub> max.
Weight	350 g max.
Dimensions	B-shape

### Circuit Configuration

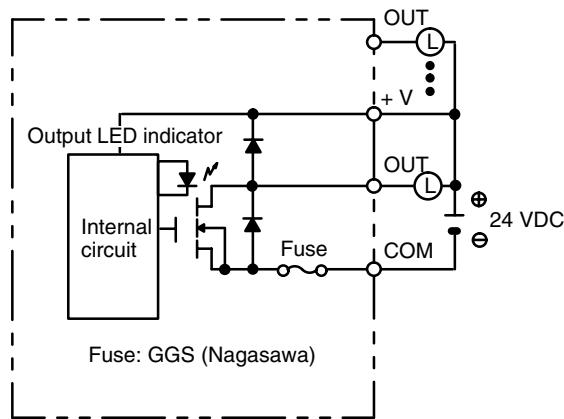

**Note** No blown fuse detector circuit is provided.

### Terminal Connections

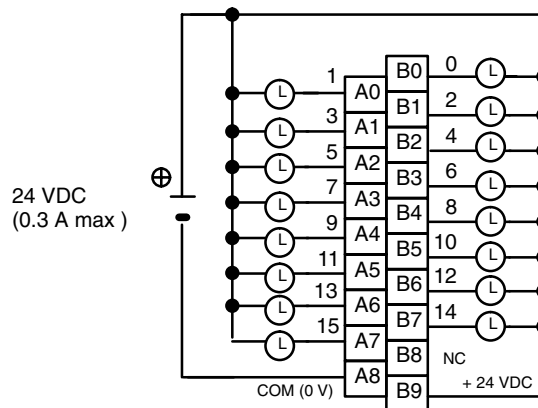

- Note**
1. Be sure to supply power to B9; otherwise current will leak through the load while the output is OFF.
  2. This Unit must be mounted to a C200H-BC□□1-V1/V2 Backplane.

### Transistor Output Unit C200H-OD213

Max. switching capacity	2.1 A 24 VDC $+10\%/_{-15\%}$ (5.2 A/Unit) NPN output
Min. switching capacity	None
Leakage Current	0.1 mA max.
Residual Voltage	1.4 V max.
ON Response Time	0.2 ms max.
OFF Response Time	0.3 ms max.
No. of Circuits	1 (8 points/common)
Internal Current Consumption	140 mA 5 VDC max.
Fuse Rating	8 A 125 V (5.2-dia.x20)
Power for External Supply	30 mA 24 VDC $+10\%/_{-15\%}$ max.
Weight	250 g max.
Dimensions	A-shape

### Circuit Configuration

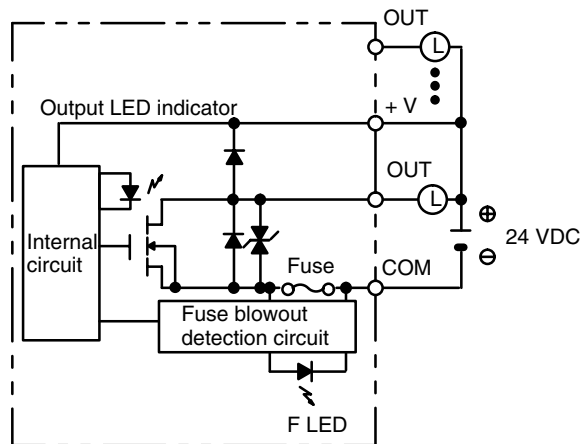

**Note** When the fuse blows F LED lights and bit 08 turns ON. Bits 08 through 15 cannot be used as work bits.

### Terminal Connections

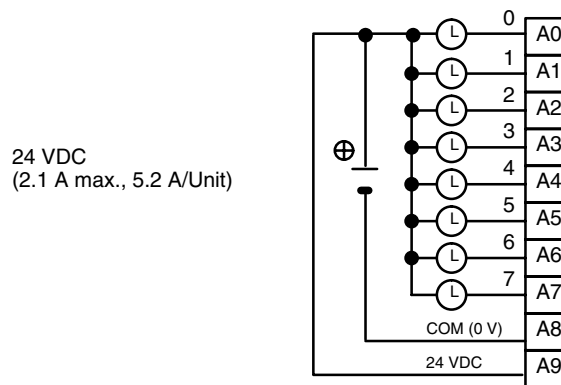

**Note** Be sure to supply power to A9; otherwise current will leak through the load while the output is OFF.

### Transistor Output Unit C200H-OD214 (Sourcing Type)

Max. switching capacity	24 VDC +10%/−15% 0.8 A (2.4 A/Unit) surge current 2 A (sourcing type) PNP output	
Min. switching capacity	None	
Leakage Current	1 mA max.	
Residual Voltage	1.5 V max.	
ON Response Time	1 ms max.	
OFF Response Time	1 ms max.	
No. of Circuits	1 (8 points/common)	
Internal Current Consumption	140 mA 5 VDC max.	
Fuse Rating	Short-circuit protection	Overcurrent protection
		Thermal protection
Power for External Supply	150 mA 24 VDC +10%/−15% max.	
Weight	250 g max.	
Dimensions	A-shape	

### Circuit Configuration

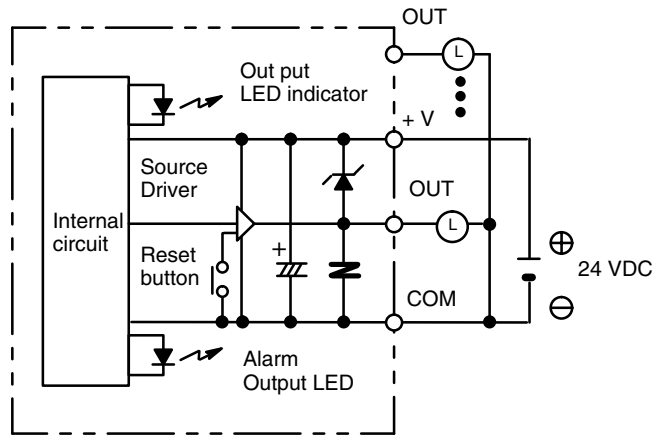

### Terminal Connections

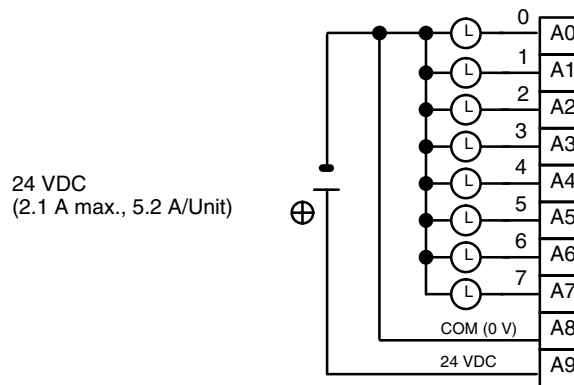

**Note** Be sure to supply power to A9; otherwise current will leak through the load while the output is OFF.



## C200H-OD214 Short-Circuit Protection

The C200H-OD214 Output Unit is equipped with two types of short-circuit protection. One is overcurrent protection, and the other is thermal protection. The short-circuit should be eliminated immediately in order to avoid damage to the Unit.

**Overcurrent Protection** When the output current reaches 2 A, the alarm output turns ON, and the alarm LED lights. Make sure the surge current of the load does not exceed 2 A, or the alarm may be activated.

**Thermal Protection** When the junction temperature of the output transistor reaches its upper limit, the output turns OFF, the alarm output turns ON, and the alarm LED blinks. But the output transistor is provided with a heat sink. So in some cases, when the output is short-circuited the thermal protection may not activate because the extra heat is dissipated by the heat sink. However, the alarm LED will still light and the alarm output will still turn ON.

**How It Works** When the short-circuit protection activates, the output displays the characteristic shown below.

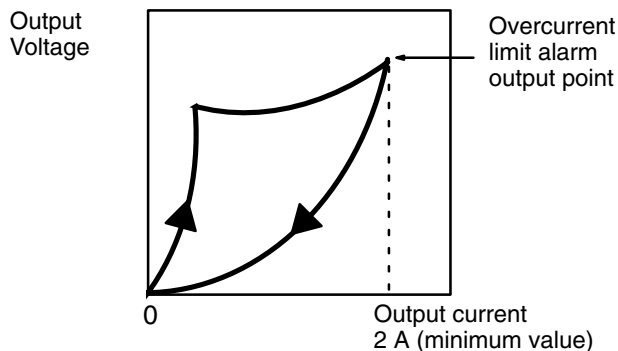

Each pair of outputs share one alarm LED and one alarm output bit as shown below (bits 12 through 15 cannot be used as work bits)

Output No.	0	1	2	3	4	5	6	7
Alarm LED No.	0	2	4	6				
Alarm Output Point No.	08	09	10	11				

Both the alarm LED and alarm output bit for the short-circuited output turn ON even if only one of the outputs is short-circuited. Both outputs should be disconnected until the short-circuit can be traced.

**Clearing the Alarm** When the short-circuit has been eliminated, reset the Unit by pressing the reset button. The alarm LED will go out, the alarm output will turn OFF, and the output will be reset.

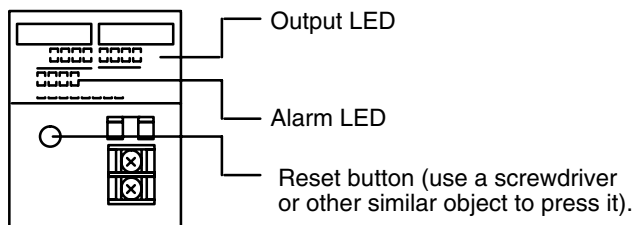

**Programming Example** If there is a short-circuit in an output, we want the program to turn that output OFF. Assume that the Unit is mounted at word 000. A program to turn OFF output bits 00 and 01 is shown below.

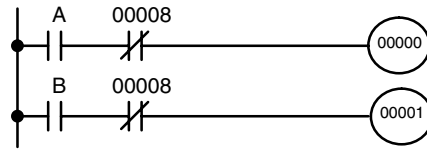

Since alarm output bit 08 covers both output bits 00 and 01, both these outputs are forced OFF as soon as output bit 08 turns ON (bits A and B can be any other bits required in the program).

### Transistor Output Unit C200H-OD216

Max. switching capacity	0.3 A 5 to 24 VDC
Min. switching capacity	10 mA 5 VDC
Leakage Current	0.1 mA max.
Residual Voltage	1.5 V max.
ON Response Time	1.5 ms max.
OFF Response Time	2 ms max.
No. of Circuits	1 (8 points/common) positive common (sourcing type)
Internal Current Consumption	10 mA 5 VDC max. 75 mA 25 VDC (8 points ON simultaneously.)
Fuse Rating	None
Power for External Supply	N/A
Weight	250 g max.
Dimensions	A-shape

### Circuit Configuration

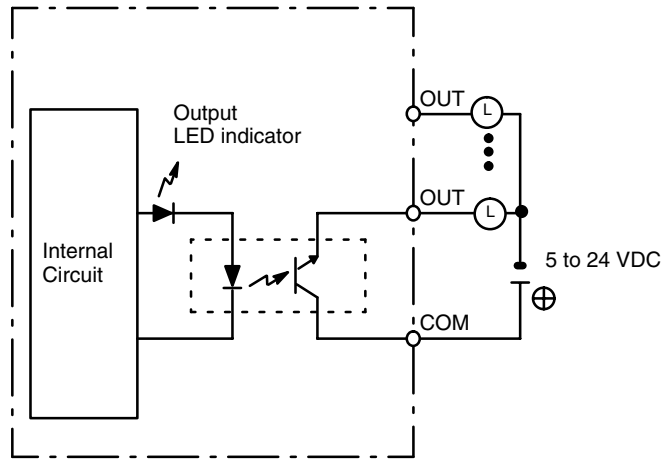

### Terminal Connections

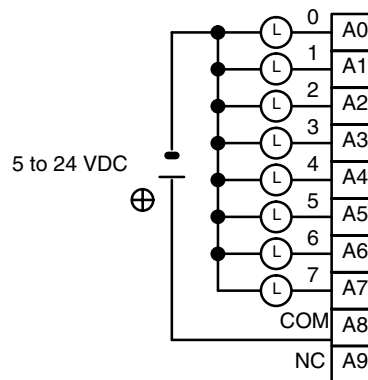

### Transistor Output Unit C200H-OD217

Max. switching capacity	0.3 A 5 to 24 VDC
Min. switching capacity	10 mA 5 VDC
Leakage Current	0.1 mA max.
Residual Voltage	1.5 V max.
ON Response Time	1.5 ms max.
OFF Response Time	2 ms max.
No. of Circuits	1 (12 points/common) positive common (sourcing type)
Internal Current Consumption	10 mA 5 VDC max. 75 mA 25 VDC (8 points ON simultaneously.)
Fuse Rating	None
Power for External Supply	N/A
Weight	300 g max.
Dimensions	B-shape

### Circuit Configuration

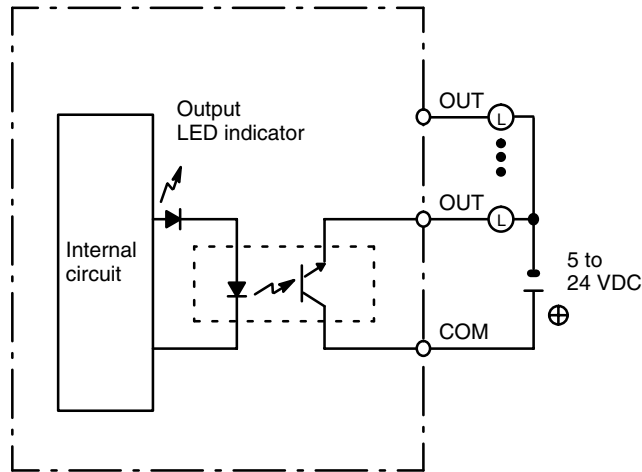

### Terminal Connections

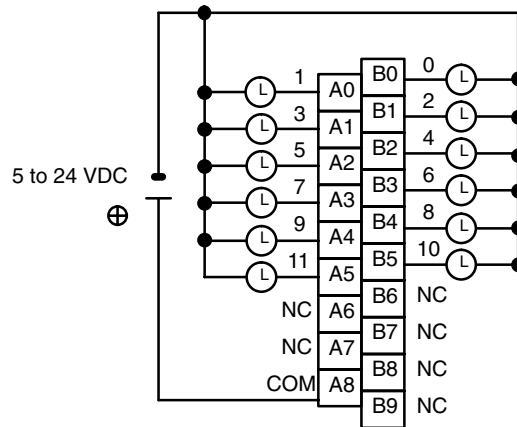

### Transistor Output Unit C200H-OD411

Max. switching capacity	12 to 48 VDC 1 A (3 A/Unit)
Min. switching capacity	None
Leakage Current	0.1 mA max.
Residual Voltage	1.4 V max.
ON Response Time	0.2 ms max.
OFF Response Time	0.3 ms max.
No. of Circuits	1 (8 points/common)
Internal Current Consumption	140 mA 5 VDC max.
Fuse Rating	5 A 125 V (5.2-dia.x20)
Power for External Supply	30 mA 12 to 48 VDC max.
Weight	250 g max.
Dimensions	A-shape

### Circuit Configuration

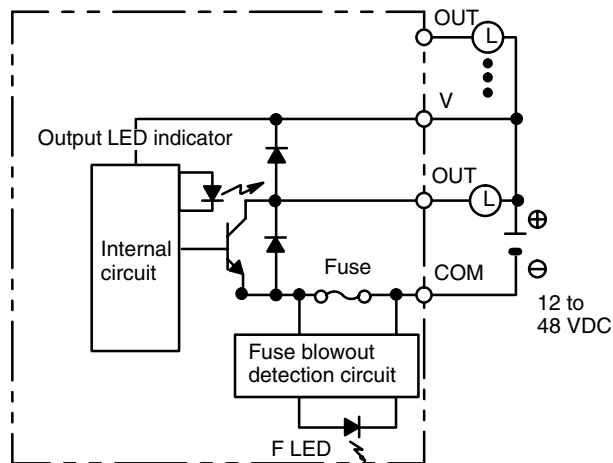

**Note** When the fuse blows F LED lights and bit 08 turns ON. Bits 08 through 15 cannot be used as work bits.

### Terminal Connections

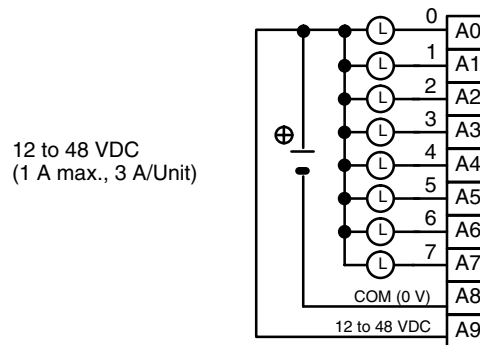

**Note** Be sure to supply power to A9; otherwise current will leak through the load while the output is OFF.

### Transistor Output Unit C200H-OD21A (Sourcing Type with Load Circuit Protection)

Max. switching capacity	24 VDC +10%/-15%, 1.0 A (4 A/Unit) surge current 1.6 A (sourcing type) PNP output	No. of Circuits	1 (16 points/common)
Min. switching capacity	None	Internal Current Consumption	160 mA, 5 VDC max.
Leakage Current	0.1 mA max.	Load Short-circuit Protection	Detection current: 1.2 A min (1.6 A typical)
Residual Voltage	0.8 V max.	Power for External Supply	35 mA 24 VDC +10%/-15% min.
ON Response Time	0.1 ms max.	Alarm Output (See note)	No. of outputs: 1 (2 kΩ internal resistor) Connectable Units: Only the following DC Input Units and alarm output LED indicators can be connected: C200H-ID001, ID211, ID212, IM211 (DC), IM212 (DC), ID215, ID501, MD115, MD215, MD501
		Weight	400 g max.
OFF Response Time	0.3 ms max.	Dimensions	B-shape

#### Circuit Configuration

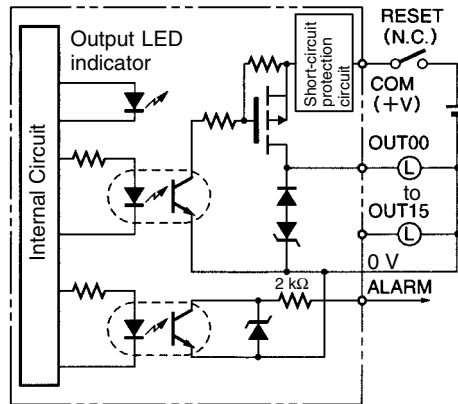

**Note** When short-circuit/overload protection is activated, all 16 outputs will be switched OFF and the ALARM output becomes active (low level). The problem can be detected externally by connecting a DC Input Unit to the ALARM output or by connecting an alarm output indicator. It's not possible to connect both the Input Unit and the indicator at the same time.

Terminal Connections

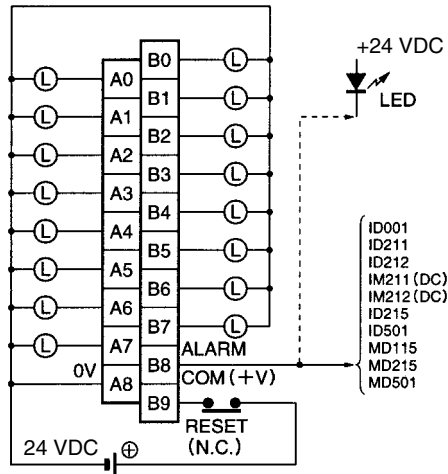

- Note** 1. When the ALARM output turns ON, remove the cause of the high current and then shut off the external power supply for approx. 1 second. After confirming that the cause has been removed, turn ON the power supply again to reset the output. As shown in the diagram, it is recommended that a relay or switch that turns ON or OFF only the external power supply be connected right before the B9 (+V). Check that this relay or switch has a contact capacity higher than the external power supply current consumption (35 mA + load current min.).
2. This Unit must be mounted to a C200H-BC□□1-V1/V2 Backplane.

### Analog Timer Unit

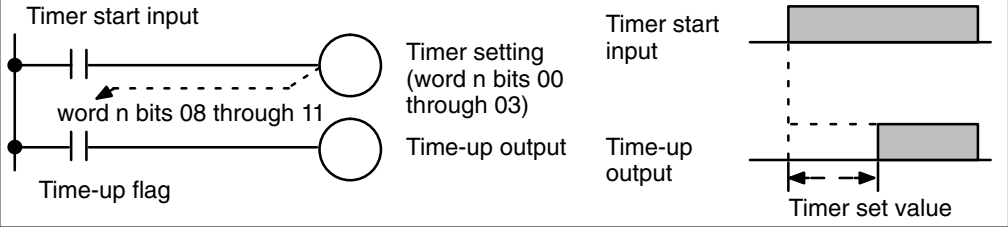
Item	Specifications																															
Oscillation Method	RC oscillation																															
Time Setting Range	Use the DIP switch to set any of the following four ranges, according to the chart shown on the next page. 0.1 to 1 second (typical) 1 to 10 seconds (typical) 10 to 60 seconds (typical) 1 to 10 minutes (typical)																															
Timer Pause Function	The timing operation can be paused if so specified by the program. Therefore, the timers can also be used as cumulative registers.																															
Number of Timer Points	4																															
Indicators	SET and TIME UP																															
External Variable Resistor	External variable resistors can be used to set the time value when the IN/EXT selector is set to OFF (EXT). Use 20 kΩ variable resistors.																															
Bit Allocation	<p>The word is determined by the system configuration.</p> <table border="1" data-bbox="475 648 784 1430"> <thead> <tr> <th>Bit</th> <th>Function</th> </tr> </thead> <tbody> <tr><td>00</td><td>T0 start output</td></tr> <tr><td>01</td><td>T1 start output</td></tr> <tr><td>02</td><td>T2 start output</td></tr> <tr><td>03</td><td>T3 start output</td></tr> <tr><td>04</td><td>T0 pause output</td></tr> <tr><td>05</td><td>T1 pause output</td></tr> <tr><td>06</td><td>T2 pause output</td></tr> <tr><td>07</td><td>T3 pause output</td></tr> <tr><td>08</td><td>T0 time-up input</td></tr> <tr><td>09</td><td>T1 time-up input</td></tr> <tr><td>10</td><td>T2 time-up input</td></tr> <tr><td>11</td><td>T3 time-up input</td></tr> <tr><td>12</td><td rowspan="4">Cannot be used</td></tr> <tr><td>13</td></tr> <tr><td>14</td></tr> <tr><td>15</td></tr> </tbody> </table> <p>                     "1" when time is running (bits 00-03)                      0 Operates / 1 Stops (bits 04-07)                      "1" when time is up (bits 08-11)                 </p>	Bit	Function	00	T0 start output	01	T1 start output	02	T2 start output	03	T3 start output	04	T0 pause output	05	T1 pause output	06	T2 pause output	07	T3 pause output	08	T0 time-up input	09	T1 time-up input	10	T2 time-up input	11	T3 time-up input	12	Cannot be used	13	14	15
Bit	Function																															
00	T0 start output																															
01	T1 start output																															
02	T2 start output																															
03	T3 start output																															
04	T0 pause output																															
05	T1 pause output																															
06	T2 pause output																															
07	T3 pause output																															
08	T0 time-up input																															
09	T1 time-up input																															
10	T2 time-up input																															
11	T3 time-up input																															
12	Cannot be used																															
13																																
14																																
15																																
Programming and Timing Chart	 <p>                     Timer start input                      Time-up flag                      Timer setting (word n bits 00 through 03)                      Time-up output                      Timer set value                 </p>																															
Internal Current Consumption	60 mA 5 VDC max.																															



**Internal variable resistors**

These variable resistors are used to set the timers. The settings of these resistors are effective only when the corresponding IN/EXT selector is ON. To set or adjust the time, use the screwdriver supplied with the Unit. Turn the variable resistor clockwise to increase the time value. The numbers 0 through 3 correspond to T0 through T3, respectively.

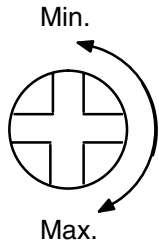

**IN/EXT selectors**

When the internal variable resistor is used, set the corresponding pin to ON; when an external variable resistor is used, set the corresponding pin to OFF. Pin numbers 4 through 1 correspond to T0 through T3, respectively.

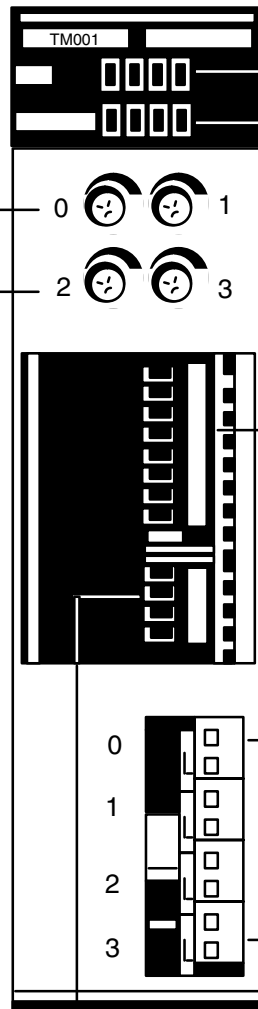

**Indicators**

The SET indicators in the top row light when the corresponding timer is operating. The TIME UP indicators in the bottom row light when the corresponding timer (T0 through T3) turns ON.

**Time range setting**

**External variable resistor connectors**

External variable resistors can also be used to set the timers. The IN/EXT selector pin must be set to the OFF position. Numbers 0 through 3 correspond to T0 through T3, respectively. Use 20-kΩ variable resistors and AWG 22 to 28 lead wires. The connector has solderless terminals and must be wired as shown below.

Timers	Pin No.	0.1 to 1 s	0.1 to 10 s	10 to 60 s	1 to 10 m
T0	8	0	1	0	1
	7	0	0	1	1
T1	6	0	1	0	1
	5	0	0	1	1
T2	4	0	1	0	1
	3	0	0	1	1
T3	2	0	1	0	1
	1	0	0	1	1

(0: OFF 1: ON)

**Caution** Ensure that the external variable resistor connectors are open when using the internal variable resistor.

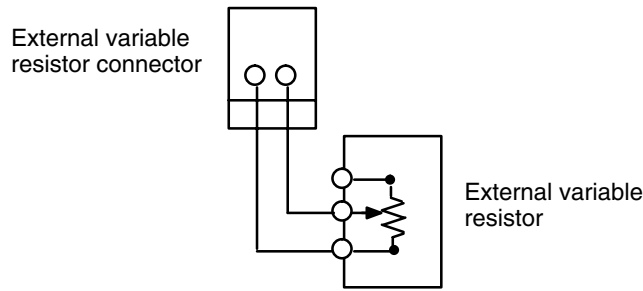

### B7A Interface Unit C200H-B7A□1 (Basic I/O Unit Type)

The B7A Interface Unit used with the B7A Link Terminal allows the transmission and reception of 16-point I/O data over two wires.

The following B7A Interface Unit and B7A Link Terminal models are available.

B7A Interface Unit	B7A Link Terminals
16-point input: C200H-B7AI1	B7A-T6□1 (Screw terminal models) B7A-T6D2 (Modular models)
16-point output: C200H-B7AO1	B7A-R6□□1 (Screw terminal models) B7A-R6A52 (Modular models)

Mount the B7A Interface Unit to the C200H-BC□□1-V1 or C200H-BC□□1-V2 Backplane.

**Note** If the B7A Interface Unit is connected to the C200H-CPU03-E or C200H-PS211, supply 24 VDC from an independent power supply to the B7A Interface Unit or use a transformer to separate the power supply line to the B7A Interface Unit from the power supply lines to the CPU and I/O Power Supply Unit.

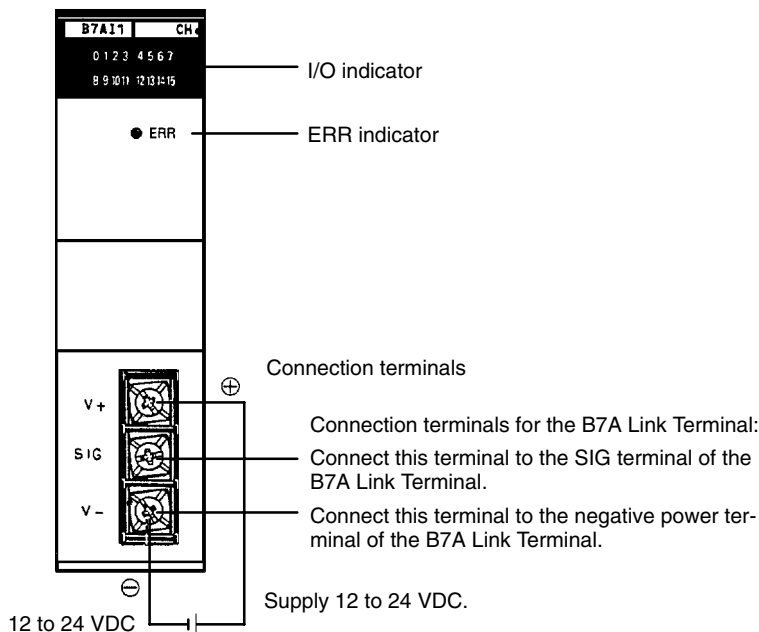

**I/O Indicator**

Indicates the ON or OFF status of input from the B7A Link Terminal or the ON and OFF status of output to the B7A Link Terminal.

**ERR Indicator**

Incorporated by the B7AI1 and lit when the B7AI1's data transmission or reception is abnormal.

**Connection Terminals**

- SIG: Connects to the SIG terminal of the B7A Link Terminal.
- V-: Connects to the negative power terminal of the B7A Link Terminal.

**Caution** If the terminals are not connected correctly, the internal circuitry of the B7A Link Terminal will be damaged.

- Note**
1. The transmission cable must be a VCTF cable with a thickness of 0.75 mm<sup>2</sup> minimum.
  2. Do not wire power lines or high-tension lines along with the transmission cable in the same conduit.

**Input Mode Selector**

The B7AI1 incorporates an input mode selector on the back panel of the Unit, with which the following modes can be set.

Input mode		15 points + 1 error	16 points
Function		Fifteen-point input from the B7A Link Terminal is effective. Bit 15 is used as transmission error bit.	Sixteen-point input from the B7A Link Terminal is effective.
Switch setting		Upper side	Lower side
Bit no. allocation	00 to 14	Input 00 to input 14	Input 00 to input 14
	15	Transmission error bit	Input 15
Status of input indicator lamp 15		Not used	Lit when input 15 is ON. Not lit when input 15 is OFF.
Status of the ERR indicator		Lit when there is a transmission error and OFF during normal transmission	

The ERR indicator is lit when an error occurs. If the error is corrected, the ERR indicator is OFF at the next transmission cycle.

When there is a transmission error, the B7A Link Terminal will hold the data just before the occurrence of the transmission error. If there is a transmission error because the B7A Link Terminal is turned off, however, data 0 is transmitted in the first transmission cycle when the B7A Link Terminal is turned on again.

Transmission errors between the C200H-B7A01 and B7A Link Terminal are detected by the B7A Link Terminal only. Check the ERR indicator and error bit for any error.

**Performance Specification**

Item	C200H-B7AI1	C200H-B7AO1
I/O points	16 points or 15 points and 1 error input	16 output points
Transmission distance	500 m max. if power is supplied to the Interface Unit and B7A Link Terminal separately. 100 m max. if power is supplied to the Interface Unit and B7A Link Terminal from a single power supply.	
Transmission delay	Typ. 19.2 ms, 31 ms max.	
Minimum input time (see note 2)	---	16 ms
Internal current consumption	5 VDC, 100 mA max.	
External power supply (see note 1)	12 to 24 VDC ±10%, 10 mA min.	12 to 24 VDC ±10%, 30 mA min.
Weight	200 g max.	

- Note**
1. The external power supply capacity does not include the capacity required by the B7A Link Terminal.
  2. The minimum input time is the minimum time required to read input signals from the CPU. Be sure that the ON/OFF width of signals sent to B7A Interface Unit output relays is at least 16 ms.

## Dimensions

### Racks

The dimensions shown below are for both the CPU Rack and Expansion I/O Rack. The C dimension for the Programming Console will increase by 30mm when the Programming Console Adapter C200H-BP001 is used, and will increase by 50 mm when the Programming Console Adapter C200H-BP002 is used.

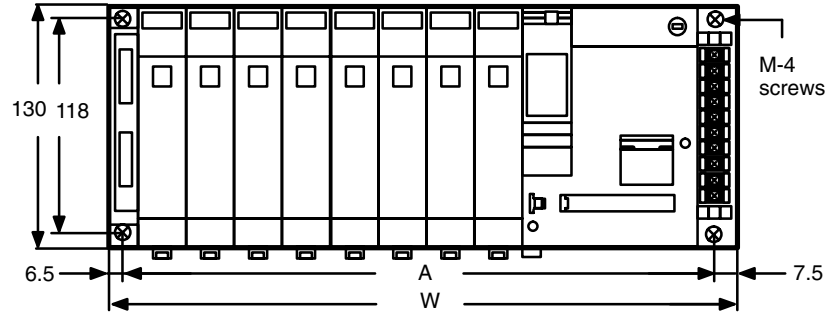

### C200H-BC101

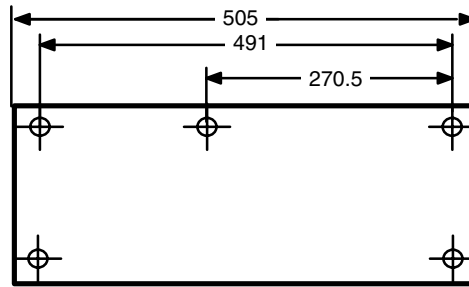

Model	A	W
C200H-BC031	246	260
C200H-BC051-V1	316	330
C200H-BC081-V1	421	435
C200H-BC101	491	505

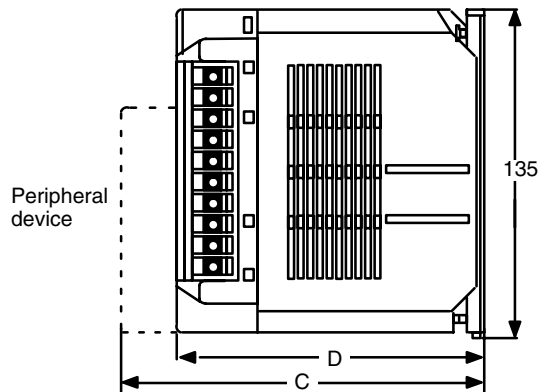

CPU Unit	D
C200H-CPU01/02/03	118
C200H-CPU11	143

Mounted Unit	C	
	CPU01/03	CPU11
Programming Console	148	173
Other peripheral devices	160	185
B-shape I/O Units	145	145
E-shape I/O Units	138	138

**I/O Units**

The dimensions shown below are for the three shapes of I/O Units mentioned throughout these specifications.

**A-shape I/O Units**

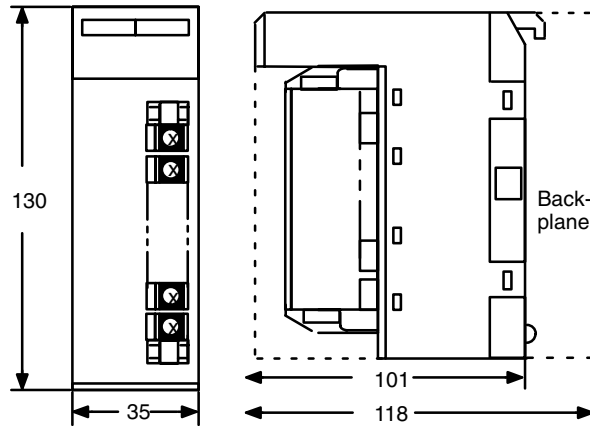

**B-shape I/O Units**

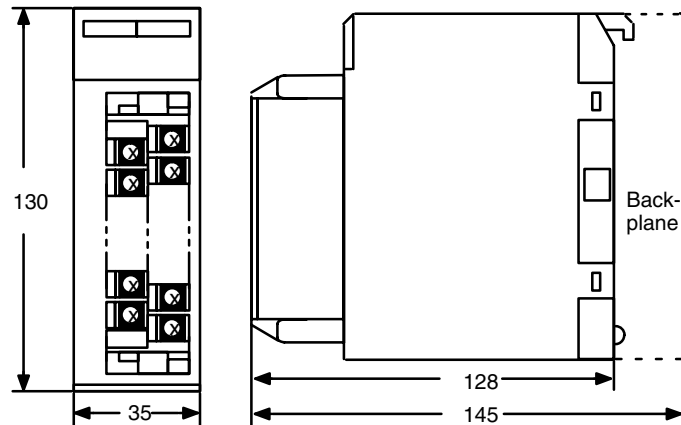

E-shape I/O Units

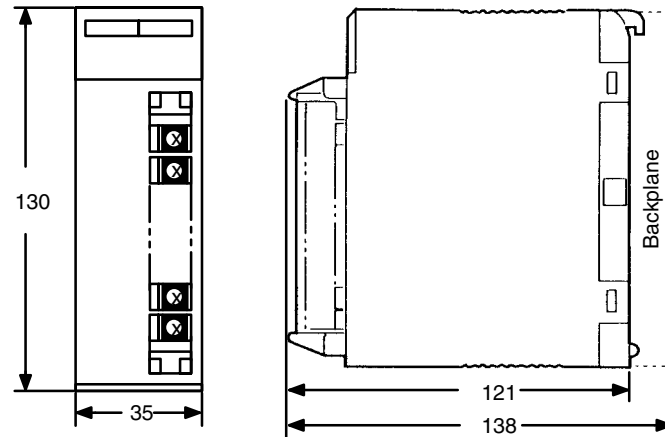

Backplane Insulation Plates

The dimensions shown below are for Backplane Insulation Plates.

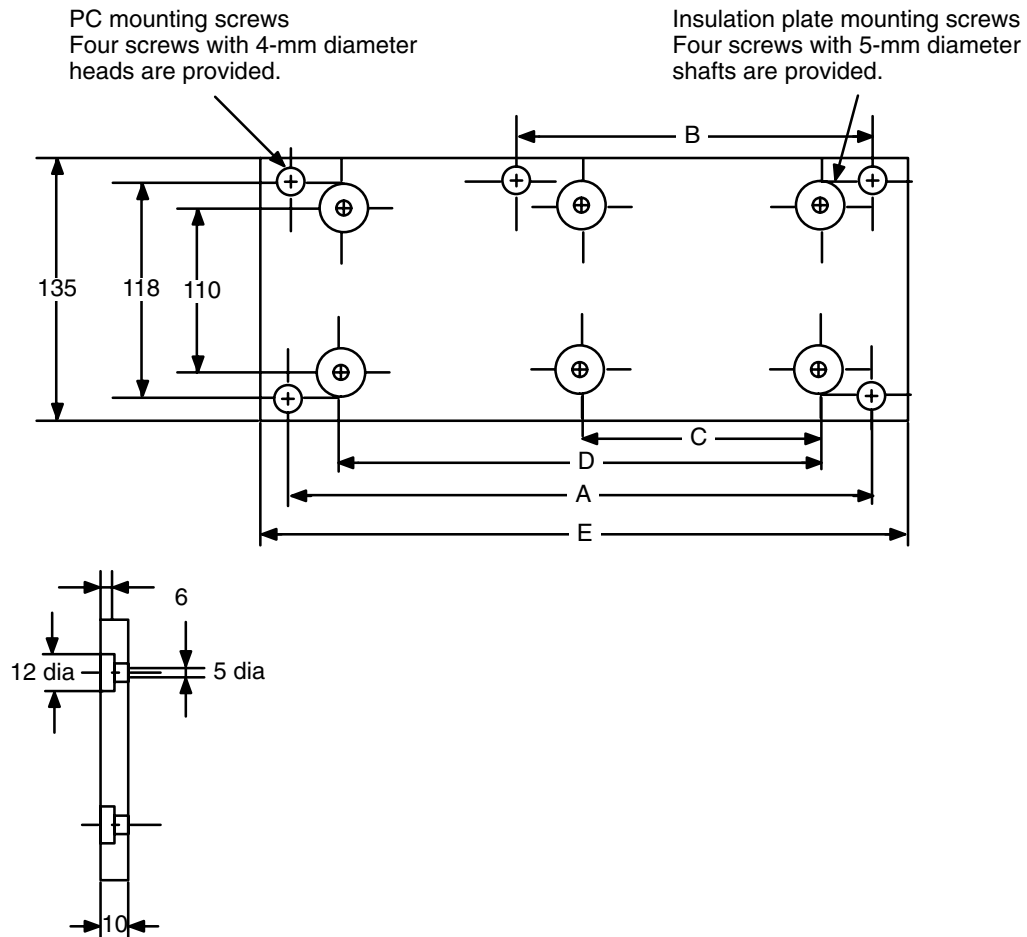

Specifications	Model	D	E	C	A	B
3 slots	C200H-ATT31	210	261	---	246	---
5 slots	C200H-ATT51	280	331	---	316	---
8 slots	C200H-ATT81	385	436	---	421	---
10 slots	C200H-ATT1	455	506	227.5	491	270.5

**I/O Connecting Cables**

The dimensions shown below are for I/O Connecting Cables.

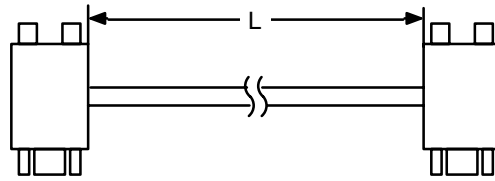

Cable	Length (L)
C200H-CN311	30 cm
C200H-CN711	70 cm
C200H-CN221	2 m
C200H-CN521	5 m
C200H-CN131	10 m





## Appendix C Standard Models

The C200H is a Rack-type PC that can be configured many different ways. Here is a series of tables listing the Units available for the C200H, along with a brief description of the Unit and its model number.

### C200H Racks

Name		Specifications	Model number	
Backplane (same for all Racks)		10 slots	C200H-BC101-V2	
		8 slots	C200H-BC081-V2	
		5 slots	C200H-BC051-V2	
		3 slots	C200H-BC031-V2	
CPU Rack	CPU	100 to 120/200 to 240 VAC (Does not support SYSMAC LINK and SYSMAC NET Link Systems.)	C200H-CPU01-E	
		100 to 120/200 to 240 VAC (Supports SYSMAC LINK and SYSMAC NET Link Systems.)	C200H-CPU11-E	
		24 VDC	C200H-CPU03-E	
	Memory Unit	CMOS-RAM Unit; built-in backup battery	UM: 3K words; DM: 1K words	C200H-MR431
			UM: 7K words; DM: 1K words	C200H-MR831
		CMOS-RAM Unit; capacitor backup	UM: 3K words; DM: 1K words	C200H-MR432
			UM: 7K words; DM: 1K words	C200H-MR832
		EPROM Unit (EPROM ordered separately)	UM: 7K words; DM: 1K words	C200H-MP831
		EEPROM Unit	UM: 3K words; DM: 1K words	C200H-ME431
	EEPROM Unit	UM: 7K words; DM: 1K words	C200H-ME831	
EPROM	27128; 150 ns; write voltage: 12.5 V	ROM-ID-B		
Expansion I/O Racks	I/O Power Supply Unit	100 to 120/200 to 240 VAC	C200H-PS221	
		24 VDC	C200H-PS211	
	I/O Connecting Cable (max. total length: 12 m)	30 cm	C200H-CN311	
		70 cm	C200H-CN711	
		2 m	C200H-CN221	
		5 m	C200H-CN521	
10 m	C200H-CN131			

## C200H I/O Units

Name		Specifications		Model number	
Input Units	AC Input Unit	8 pts	100 to 120 VAC	C200H-IA121	
		16 pts	100 to 120 VAC	C200H-IA122/IA122V	
		8 pts	200 to 240 VAC	C200H-IA221	
		16 pts	200 to 240 VAC	C200H-IA222/IA222V	
	DC Input Unit	8 pts	No-voltage contact; NPN	C200H-ID001	
		8 pts	No-voltage contact; PNP	C200H-ID002	
		8 pts	12 to 24 VDC	C200H-ID211	
		16 pts	24 VDC	C200H-ID212	
	AC/DC Input Unit	8 pts	12 to 24 VAC/DC	C200H-IM211	
		16 pts	24 VAC/DC	C200H-IM212	
	Output Units	Relay Output Unit	8 pts	2 A, 250 VAC/24 VDC (For resistive loads)	C200H-OC221
			12 pts	2 A, 250 VAC/24 VDC (For resistive loads)	C200H-OC222
16 pts			2 A, 250 VAC/24 VDC (For resistive loads)	C200H-OC225	
5 pts			2 A, 250 VAC/24 VDC (For resistive loads) Independent commons	C200H-OC223	
8 pts			2 A, 250 VAC/24 VDC (For resistive loads) Independent commons	C200H-OC224	
Triac Output Unit		8 pts	1 A, 120 VAC	C200H-OA121-E	
		8 pts	1.2 A, 120 VAC	C200H-OA122-E	
		8 pts	1.2 A, 250 VAC	C200H-OA223	
		12 pts	0.3 A, 250 VAC	C200H-OA222V	
		12 pts	0.5 A, 250 VAC	C200H-OA224	
Transistor Output Unit		8 pts	1 A, 12 to 48 VDC	C200H-OD411	
		12 pts	0.3 A, 24 VDC	C200H-OD211	
		16 pts	0.3 A, 24 VDC	C200H-OD212	
		8 pts	2.1 A, 24 VDC	C200H-OD213	
		8 pts	0.8 A, 24 VDC; sourcing type (PNP); with load short protection	C200H-OD214	
		8 pts	5 to 24 VDC; sourcing type (PNP)	C200H-OD216	
		12 pts	5 to 24 VDC; sourcing type (PNP)	C200H-OD217	
		16 pts	1 A, 24 VDC; sourcing type (PNP); with load short protection	C200H-OD21A	
Analog Timer Unit		4 timer pts	0.1 to 1 s, 1 to 10 s, 10 to 60 s, or 1 min to 10 min (switchable)	C200H-TM001	
		Variable Resistor Connector (Related Product)		Connector with lead wire (2 m) for 1 external resistor	C4K-CN223
B7A Interface Units (Basic I/O Units)		15 or 16 input pts	Connects to B7A Link Terminals.	C200H-B7A11	
		16 out- put pts		C200H-B7A01	

**Note** The C200H-OC225/OD212/OD21A 16-point Output Unit and the C200H-B7A01 B7A Interface Unit must be mounted to a C200H-BC□□1-V1/V2 Backplane.

## C200H Special I/O Units

All of the following are classified as Special I/O Units except for the ASCII Unit, which is an Intelligent I/O Unit.

Name		Specifications		Model number
High-density I/O Units	DC Input Units	32 pts	5 VDC (TTL inputs); with high-speed input function	C200H-ID501
		32 pts	24 VDC; with high-speed inputs	C200H-ID215
	Transistor Output Units	32 pts	0.1 A, 24 VDC (usable as 128-point dynamic output unit)	C200H-OD215
		32 pts	35 mA, 5 VDC (TTL outputs) (usable as 128-point dynamic output unit)	C200H-OD501
	DC Input/Transistor Output Units	16 input/16 output pts	12-VDC inputs; with high-speed input function 0.1 A, 12-VDC outputs (usable as 128-point dynamic input unit)	C200H-MD115
		16 input/16 output pts	24-VDC inputs; with high-speed input function 0.1 A, 24-VDC outputs (usable as 128-point dynamic input unit)	C200H-MD215
16 input/16 output pts		5 VDC (TTL inputs); with high speed input function 35 mA, 5 VDC Output (TTL outputs) (usable as 128-point dynamic input unit)	C200H-MD501	
Analog I/O Units	Analog Input Unit	1 to 5/0 to 10 V; 4 inputs		C200H-AD001
		4 to 20 mA, 1 to 5/0 to 10/-10 to 10 V; 8 inputs		C200H-AD002
	Analog Output Unit	1 to 5/0 to 10 V; 2 outputs		C200H-DA001
		4 to 20 mA, -10 to 10 V; 4 outputs		C200H-DA002
Temperature Sensor Units		Thermocouple (K(CA) or J(IC)) (switchable); 4 inputs		C200H-TS001
		Thermocouple (K(CA) or L(Fe-CuNi)) (switchable); 4 inputs		C200H-TS002
		Platinum resistance thermometer (JPt) (switchable), DIN standards; 4 inputs		C200H-TS101
		Platinum resistance thermometer (Pt) (switchable); 4 inputs		C200H-TS102
Temperature Control Units		Thermocouple	Transistor output	C200H-TC001
			Voltage output	C200H-TC002
			Current output	C200H-TC003
		Platinum resistance thermometer	Transistor output	C200H-TC101
			Voltage output	C200H-TC102
			Current output	C200H-TC103
Heat/Cool Temperature Control Units		Thermocouple	Transistor output	C200H-TV001
			Voltage output	C200H-TV002
			Current output	C200H-TV003
		Platinum resistance thermometer	Transistor output	C200H-TV101
			Voltage output	C200H-TV102
			Current output	C200H-TV103
PID Control Units		Transistor output		C200H-PID01
		Voltage output		C200H-PID02
		Current output		C200H-PID03

Name	Specifications		Model number
Position Control Units	1 axis	Pulse output; speeds: 1 to 99,990 pps	C200H-NC111
	1 axis	Directly connectable to servomotor driver; compatible with line driver; speeds: 1 to 250,000 pps	C200H-NC112
	2 axis	1 to 250000. pps. 53 pts per axis	C200H-NC211
Cam Positioner Unit	Detects angles of rotation by means of a resolver and provides ON and OFF outputs at specified angles. A maximum of 48 cam outputs (16 external outputs and 32 internal outputs) maximum are available.		C200H-CP114
High-speed Counter Units	1 axis	Pulse input; counting speed: 50 kcps; 5 VDC/12 VDC/24 VDC	C200H-CT001-V1
	1 axis	Pulse input; counting speed: 75 kcps; RS-422 line driver	C200H-CT002
ASCII Unit	EEPROM		C200H-ASC02
I/D Sensor Units	Local application, electromagnetic coupling		C200H-IDS01-V1
	Remote application, microwave transmissions		C200H-IDS21
	Read/Write Head	Electromagnetic type	V600-H series
		Microwave type	V620-H series
	Data Carrier (see note)	SRAM type for V600-H series.	V600-D□□R□□
EEPROM type for V600-H series.		V600-D□□P□□	
Voice Unit	60 messages max.; message length: 32, 48, or 64 s (switchable)		C200H-OV001
	Connecting Cable	RS-232C	C200H-CN224
Fuzzy Logic Unit	Up to 8 inputs and 4 outputs. (I/O to and from specified data area words)		C200H-FZ001

**Note** For Read/Write Head and Data Carrier combinations, refer to the *V600 FA ID System R/W Heads and EEPROM Data Carriers Operation Manual and Supplement* or *V600 FA ID System R/W Heads and SRAM Data Carriers Operation Manual and Supplement*.

## C200H Link Units

Name	Specifications			Model number
Host Link Unit	Rack-mounting	C200H only	APF/PCF	C200H-LK101-PV1
			RS-422	C200H-LK202-V1
			RS-232C	C200H-LK201-V1
	CPU-mounting	C1000H/C2000H C500 C200H C120	PCF	3G2A6-LK101-EV1
			APF/PCF	3G2A6-LK101-PEV1
			RS-232C	3G2A6-LK201-EV1
PC Link Unit	Multilevel		RS-485	C200H-LK401
Remote I/O Master Unit	Up to two per PC; connectable to up to 5 Slaves per PC total		APF/PCF	C200H-RM001-PV1
			Wired	C200H-RM201
Remote I/O Slave Unit	100 to 120/200 to 240 VAC (switchable)		APF/PCF	C200H-RT001-P
	24 VDC			C200H-RT002-P
	100 to 120/200 to 240 VAC (switchable)		Wired	C200H-RT201
	24 VDC			C200H-RT202

## Optional Products

Name	Specifications	Model number
I/O Unit Cover	Cover for 10-pin terminal block	C200H-COV11
Terminal Block Cover	Short protection for 10-pin terminal block	C200H-COV02
	Short protection for 19-pin terminal block	C200H-COV03
Connector Cover	Protective cover for unused I/O Connecting Cable connectors	C500-COV01
Space Unit	Used for vacant slots	C200H-SP001
Battery Set	For C200H RAM Memory Unit only	C200H-BAT09
Relay	24 VDC	G6B-1174P-FD-US DC24
Backplane Insulation Plate	For 10-slot Backplane	C200H-ATTA1
	For 8-slot Backplane	C200H-ATT81
	For 5-slot Backplane	C200H-ATT51
	For 3-slot Backplane	C200H-ATT31
I/O Bracket	For 5-slot Backplane	C200H-ATT53
	For 8-slot Backplane	C200H-ATT83
	For 3-slot Backplane	C200H-ATT33
Memory Unit Lock Fitting	To secure Memory Unit to CPU	C200H-ATT03
External Connector	Solder terminal; 40 pin with connector cover	C500-CE401
	Solderless terminal; 40 pin with connector cover (crimp-type)	C500-CE402
	Pressure welded terminal; 40 pin	C500-CE403
	Solder terminal; 40 pin with connector cover (right-angle type)	C500-CE404
	Solderless terminal; 40 pin with connector cover (right-angle type)	C500-CE405
	Solder terminal; 24 pin with connector cover	C500-CE241
	Solderless terminal; 24 pin with connector cover (crimp-type)	C500-CE242
	Pressure welded terminal; 24 pin	C500-CE243

## Optical Units

Name	Specifications	Model no.					
Optical I/O Unit	No-voltage Input Unit	8 pts.	100 to 120 VAC power supply	APF/PCF	3G5A2-ID001-PE		
				PCF	3G5A2-ID001-E		
	AC/DC Input Unit	12 to 24 VAC/DC 8 pts.			APF/PCF	3G5A2-IM211-PE	
					PCF	3G5A2-IM211-E	
	AC Input Unit	100 to 120 VAC 8 pts.			APF/PCF	3G5A2-IA121-PE	
					PCF	3G5A2-IA121-E	
	Relay Output Unit	2A, 250 VAC/24 VDC (w/relay socket) 8 pts.	100 to 120/200 to 240 VAC power supply			APF/PCF	3G5A2-OC221-PE
						PCF	3G5A2-OC221-E
	Triac Output Unit	1A, 100 to 120/200 to 240 VAC (w/built-in surge killer) 8 pts.				APF/PCF	3G5A2-OA222-PE
						PCF	3G5A2-OA222-E
Transistor Output Unit	0.3 A, 12 to 48 VDC 8 pts.			APF/PCF	3G5A2-OD411-PE		
Repeater Unit	Connected between 32nd and 33rd Units when connecting more than 33 Units in a Remote Subsystem; power supply: 85 to 250 VAC.			APF/PCF	3G5A2-RPT01-PE		
				PCF	3G5A2-RPT01-E		

## Link Adapters

Name	Specifications	Model no.
Link Adapter	3 RS-422 connectors	3G2A9-AL001
	3 optical connectors (APF/PCF)	3G2A9-AL002-PE
	3 optical connectors (PCF)	3G2A9-AL002-E
	1 connector for RS-232C; 2 for RS-422	3G2A9-AL003
	1 connector each for APF/PCF, RS-422, and RS-232C	3G2A9-AL004-PE
	1 connector each for PCF, RS-422, and RS-232C	3G2A9-AL004-E
	1 connector each for APF/PCF and APF	3G2A9-AL005-PE
	1 connector each for PCF and AGF	3G2A9-AL005-E
	1 connector for APF/PCF; 2 for AGF	3G2A9-AL006-PE
	1 connector for PCF; 2 for AGF	3G2A9-AL006-E
	O/E converter; 1 connector for RS-485, 1 connector each for APF/PCF	B500-AL007-PE
	Used for on-line removal of FIT or SYSMAC NET Link Units from the SYSMAC NET Link System, SYSMAC NET Optical Link Adapter 3 connectors for APF/PCF.	B700-AL001

## DIN Products

Name	Specifications	Model number
DIN Track Mounting Bracket	1 set (1 included)	C200H-DIN01
DIN Track	Length: 50 cm; height: 7.3 cm	PFP-50N
	Length: 1 m; height: 7.3 cm	PFP-100N
	Length: 1 m; height: 16 mm	PFP-100N2

## Optical Fiber Cable

**Plastic Optical Fiber Cable (APF)** APF stands for "All-Plastic Fiber". This cable can be used to connect only Units having the suffix "-P" in their model number. The maximum length is 20 m. The 3G5A2-PF002 cable comes without connectors and must be assembled by the user.

Product	Description	Model no.
Plastic Optical Fiber Cable	Cable only (optical connectors not provided) Order in units of 5 m for cable less than 100 m, or in units of 200 m or 500 m.	3G5A2-PF002
Optical Connector A	2 pcs (brown), for plastic Optical fiber 10 m long max.	3G5A2-CO001
Optical Connector B	2 pcs (black) for plastic Optical fiber 8 to 20 m long	3G5A2-CO002
Plastic Optical Fiber Cable	1 m, w/optical connector A provided at both ends	3G5A2-PF101

**Plastic-Clad Optical Fiber Cable (PCF)** PCF stands for “Plastic-Clad Fiber”. This cable can be used to connect any Units. The maximum length for Units having the suffix “-P” in their model number is 200 m. The maximum length for Units without the suffix “-P” in their model number is 800 m.

Product	Description		Model no.
Optical Fiber Cable (for indoors)	0.1 m, w/connector	Ambient temperature: -10° to 70°C	3G5A2-OF011
	1 m, w/connector		3G5A2-OF101
	2 m, w/connector		3G5A2-OF201
	3 m, w/connector		3G5A2-OF301
	5 m, w/connector		3G5A2-OF501
	10 m, w/connector		3G5A2-OF111
	20 m, w/connector		3G5A2-OF211
	30 m, w/connector		3G5A2-OF311
	40 m, w/connector		3G5A2-OF411
	50 m, w/connector		3G5A2-OF511
Optical Fiber Cable (for outdoors)	1 to 500 m (Order in Units of 10 m)	Ambient temperature: -10° to 70°C	3G5A2-OF002
	501 to 800 m (Order in Units of 10 m)	Ambient temperature: 0° to 55°C (Must not be subjected to direct sunlight)	

**Crystal Optical Fiber Cable (AGF)** AGF stands for “All-Glass Fiber”. Crystal optical fiber cable is not available from OMRON.

## Cable Length

The connectors may be difficult to attach to the cables. Therefore, always leave a little extra length when cutting the cable. The lengths given for pre-assembled cables are as shown below.

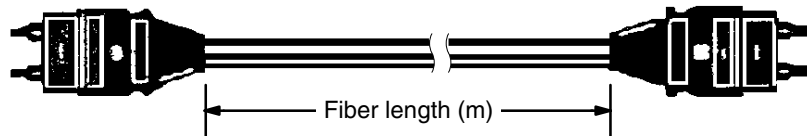

## Peripheral Devices

Product	Description		Model no.	
Programming Console	Vertical, w/backlight		3G2A5-PRO13-E	
	Horizontal, w/backlight		3G2A6-PRO15-E	
	Vertical type, w/backlight (Connecting cable required)		C200H-PRO27-E	
Data Access Console	Connecting cable required		C200H-DAC01	
Programming Console and Data Access Console Connecting Cables	For vertical type	2 m	C200H-CN222	
		4 m	C200H-CN422	
Data Setting Console	Used for data input and process value display for the C200H-TC□□□□/C200H-TV□□□□/200H-PID□□□.		C200H-DSC01	
Data Setting Console Connecting Cables	For C200H-DSC01	2 m	C200H-CN225	
		4 m	C200H-CN425	
Panel Mounting Bracket	For vertical Programming Console, Data Access Console		C200H-ATT01	
Cassette Tape Recorder Connecting Cable	1 m		SCYP0R-PLG01	
PROM Writer	For C-series PCs (12.5/21 V)		C500-PRW06	
Floppy Disk Interface Unit	For C-series PCs		3G2C5-FDI03-E	
Printer Interface Unit	For C-series PCs		3G2A5-PRT01-E	
Memory Pack (for Printer Interface)	For C200H/C1000H/C2000H		C2000-MP103-EV3	
Printer Connecting Cable	For printer, 2 m		SCY-CN201	
Peripheral Interface Unit	High-density I/O 12-/16-point I/O Special I/O Unit		C200H-IP006	
Connecting Cable	To connect GPC to Peripheral Interface Unit	2 m	3G2A2-CN221	
		5 m	C500-CN523	
		10 m	C500-CN131	
		20 m	C500-CN231	
		30 m	C500-CN331	
		40 m	C500-CN431	
		50 m	C500-CN531	
Graphic Programming Console	100 to 120 VAC, w/comment		3G2C5-GPC03-E	
Memory Pack	For C200H/C1000H/C2000H		3G2C5-MP304-EV3	
CRT Interface Unit	For connection between GPC and CRT		C500-GDI01	
Programming Console Mounting Base	To attach peripheral devices to the CPU with B-type or E-type I/O Units mounted to the CPU Rack.	Space between the Programming Console Adapter and CPU surface.	29 mm	C200H-BP001
			49 mm	C200H-BP002

## SYSMAC Support Software (SSS)

Product	Description	Model no.
SYSMAC Support Software	3.5", 2HD for IBM PC/AT compatible	
	Connection Cable	
		C500-ZL3AT1-E
		CQM1-CIF02
		CV500-CIF01



## SYSMAC LINK Unit/SYSMAC NET Link Unit

If you are using any of the Units listed in the table below, they must be mounted to a CPU Rack that uses model C200H-CPU11-E as the CPU. Otherwise, these Units will not operate properly.

Name	Specifications		Model number	
SYSMAC LINK Unit	Wired via coaxial cable. Must be mounted to leftmost 2 slots on Rack with C200H-CPU11-E	918 data link words	C200HW-SLK23	
		2,966 data link words	C200HW-SLK24	
	Wired via optical fiber cable. Bus Connection Unit required separately. May be used with APS Power Supply Unit.	918 data link words	C200HW-SLK13	
		2,966 data link words	C200HW-SLK14	
	Terminator	One required for each node at ends of System		C1000H-TER01
	Attachment Stirrup	Provided with SYSMAC LINK Unit		C200H-TL001
F Adapter	---		C1000H-CE001	
F Adapter Cover	---		C1000H-COV01	
Communications Cable	Coaxial cables	Manufactured by Hitachi	ECXF5C-2V	
		Manufactured by Fujigura	5C-2V	
Auxiliary Power Supply Unit	For use with the C200H-SLK13/SLK14		C200H-APS03	
SYSMAC NET Link Unit	Must be mounted to leftmost 2 slots on Rack with C200H-CPU11-E		C200HS-SNT32	
Power Supply Adapter	Required when supplying power from Central Power Supply	For 1 Unit	C200H-APS01	
		For 2 Units	C200H-APS02	
Power Cable	Connects Power Supply Adapter and SYSMAC NET Link Unit	For 1 Unit	C200H-CN111	
		For 2 Units	C200H-CN211	
Bus Connection Unit	Connects SYSMAC LINK Unit or SYSMAC NET Link Unit to CPU	For 1 Unit	C200H-CE001	
		For 2 Units	C200H-CE002	



# Appendix D

## Programming Console Operation

### System Operations

Operation	Mode			Key Sequence
	RUN	MON.	PROG.	
Data All Clear	NO	NO	YES	
I/O Table Register	NO	NO	YES	
I/O Table Verify	YES	YES	YES	
I/O Table Read	YES	YES	YES	
Setting Address	YES	YES	YES	
Error Message Read	YES	YES	YES	

### Programming Operations

Operation	Mode			Key Sequence
	RUN	MON.	PROG.	
Setting Address	YES	YES	YES	
Program Read	YES	YES	YES	<p>Address currently displayed</p>
Search	YES	YES	YES	
Instruction Insert and Instruction Delete	NO	NO	YES	<p>Locate position in program then enter</p> <p>[Instruction] → INS → ↓</p> <p>Instruction currently displayed → DEL → ↑</p>
Program Check	NO	NO	YES	

### Monitoring and Data Change Operations

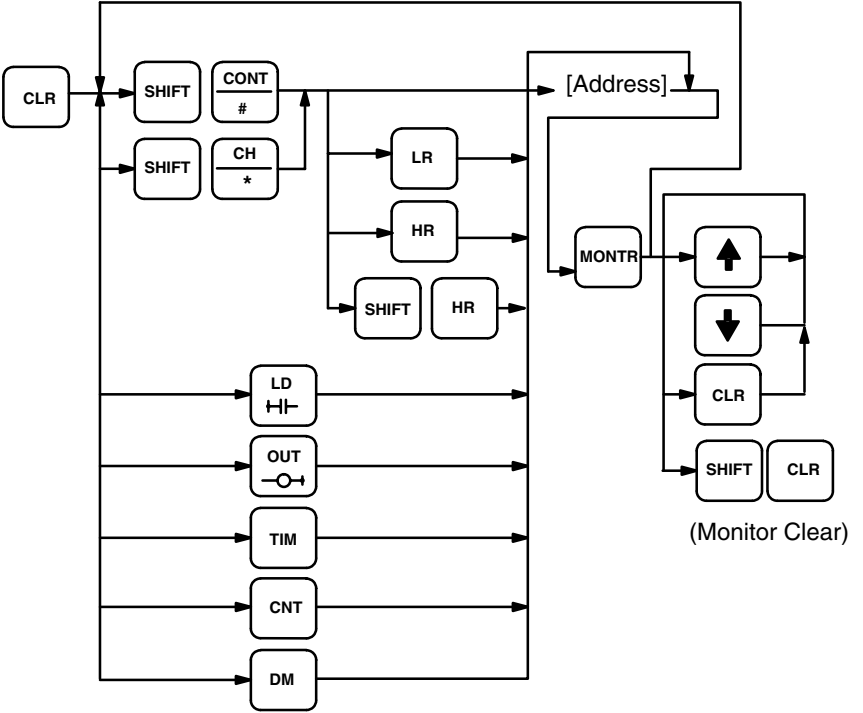
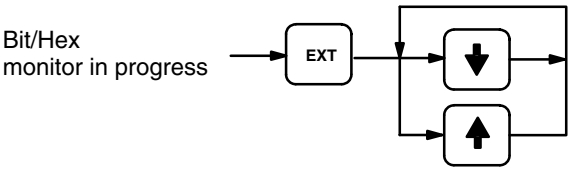
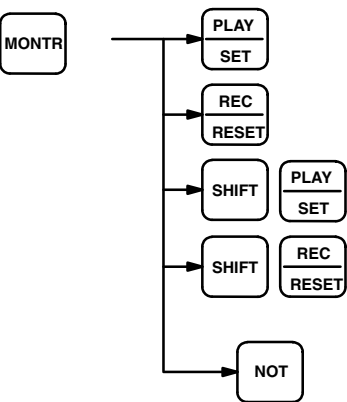
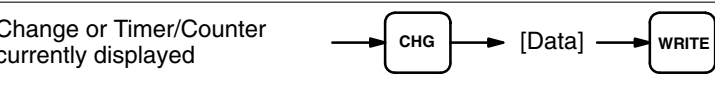
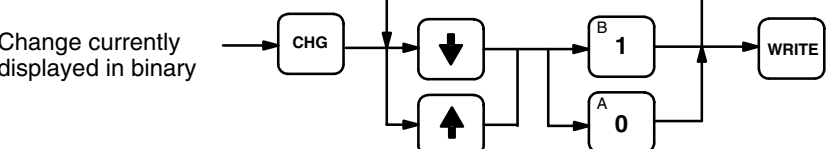
Operation	Mode			Key Sequence
	RUN	MON.	PROG.	
Monitor	YES	YES	YES	
3 Word Monitor	NO	NO	YES	<p>Bit/Hex monitor in progress</p> 
Forced Set/Reset	NO	YES	YES	
PV Change 1	NO	YES	YES	<p>Change or Timer/Counter currently displayed</p> 
PV Change 2	NO	YES	YES	<p>Change currently displayed in binary</p> 

Operation	Mode			Key Sequence
	RUN	MON.	PROG.	
SV Increment/Decrement, SV Reset	NO NO	YES YES	YES NO	Timer/Counter currently displayed → [Down Arrow] → CHG → EXT → [Down Arrow] / [Up Arrow] → [New SW] → WRITE
3-Word Change	NO	YES	YES	3 Word Monitor in progress → CHG → [Data] → WRITE
Cycle Time Read	YES	YES	NO	CLR → MONTR ..... MONTR
HEX-ASCII Display Convert	YES	YES	YES	Word currently displayed → TR

### Cassette Tape Operations

Operation	Mode			Key Sequence
	RUN	MON.	PROG.	
Cassette Tape Write	NO	NO	YES	<p>Wait for about 5 seconds. (Cancel with the CLR key.)</p>
Cassette Tape Read	NO	NO	YES	<p>Wait for about 5 seconds.</p>
Cassette Tape Verify	NO	NO	YES	<p>Wait for about 5 seconds.</p>
DM<-> Cassette Tape	NO	NO	YES	<p>5 second tape leader</p>





# Appendix E

## Programming Instructions

### Basic Instructions

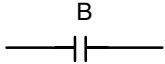
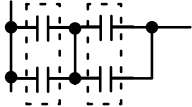
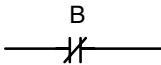
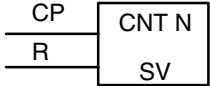
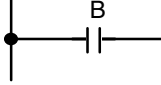
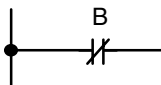
Name Mnemonic	Symbol	Function	Operand Data Areas
<b>AND</b> AND		Logically ANDs the status of the designated bit with the current execution condition.	<b>B:</b> IR SR HR AR LR TC
<b>AND LOAD</b> AND LD		Logically ANDs the resultant execution conditions of the preceding logic blocks.	None
<b>AND NOT</b> AND NOT		Logically ANDs the inverse of the designated bit with the current execution condition.	<b>B:</b> IR SR HR AR LR TC
<b>COUNTER</b> CNT		A decrementing counter. SV: 0 to 9999; CP: count pulse; R: reset input. The TC bit is entered as a constant.	<b>N:</b> TC  <b>SV:</b> IR HR AR LR DM #
<b>LOAD</b> LD		Defines the status of bit B as the execution condition for subsequent operations in the instruction line.	<b>B:</b> IR SR HR AR LR TC TR
<b>LOAD NOT</b> LD NOT		Defines the status of the inverse of bit B as the execution condition for subsequent operations in the instruction line.	<b>B:</b> IR SR HR AR LR TC

#### Data Areas

These footnote tables show the actual ranges of all data areas. Bit numbers are provided (except for DM and TC areas); remove the rightmost two digits for word numbers.

IR	SR	HR	TR	AR	LR	TC	DM	#
00000 to 23515	23600 to 25507	HR 0000 to 9915	TR 0 to 7	AR 0000 to 2715	LR 0000 to 6315	TC 000 to 511	Read/Wr: DM 0000 to DM 0999 Rd only: DM 1000 to DM 1999	0000 to 9999 or 0000 to FFFF

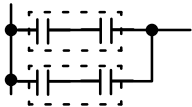
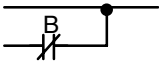
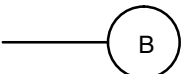
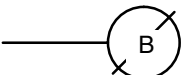
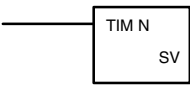
Name Mnemonic	Symbol	Function	Operand Data Areas
<b>OR</b> OR		Logically ORs the status of the designated bit with the current execution condition.	<b>B:</b> IR SR HR AR LR TC
<b>OR LOAD</b> OR LD		Logically ORs the resultant execution conditions of the preceding logic blocks.	None
<b>OR NOT</b> OR NOT		Logically ORs the inverse of the designated bit with the execution condition.	<b>B:</b> IR SR HR AR LR TC
<b>OUTPUT</b> OUT		Turns ON B for an ON execution condition; turns OFF B for an OFF execution condition.	<b>B:</b> IR SR HR AR LR TR
<b>OUTPUT NOT</b> OUT NOT		Turns OFF B for an ON execution condition; turns ON B for an OFF execution condition.	<b>B:</b> IR SR HR AR LR
<b>TIMER</b> TIM		ON-delay (decrementing) timer operation. Set value: 000.0 to 999.9 s. The same TC bit cannot be assigned to more than one timer/counter. The TC bit is entered as a constant.	<b>N:</b> TC  <b>SV:</b> IR HR AR LR DM #

## Special Instructions

Name Mnemonic	Symbol	Function	Operand Data Areas
<b>NO OPERATION</b> NOP(00)	None	Nothing is executed and program operation moves to the next instruction.	None

### Data Areas

These footnote tables show the actual ranges of all data areas. Bit numbers are provided (except for DM and TC areas); remove the rightmost two digits for word numbers.

IR	SR	HR	TR	AR	LR	TC	DM	#
00000 to 23515	23600 to 25507	HR 0000 to 9915	TR 0 to 7	AR 0000 to 2715	LR 0000 to 6315	TC 000 to 511	Read/Wr: DM 0000 to DM 0999 Rd only: DM 1000 to DM 1999	0000 to 9999 or 0000 to FFFF

Name Mnemonic	Symbol	Function	Operand Data Areas
<b>END</b> END(01)		Required at the end of each program. Instructions located after END(01) will not be executed.	None
<b>INTERLOCK</b> IL(02) <b>INTERLOCK CLEAR</b> ILC(03)	 	If an interlock condition is OFF, all outputs and all timer PVs between the current IL(02) and the next ILC(03) are turned OFF or reset, respectively. Other instructions are treated as NOP. Counter PVs are maintained. If the execution condition is ON, execution continues normally.	None
<b>JUMP</b> JMP(04) <b>JUMP END</b> JME(05)	 	When the execution condition for the JMP(04) instruction is ON, all instructions between JMP(04) and the corresponding JME(05) are to be ignored or treated as NOP(00). For direct jumps, the corresponding JMP(04) and JME(05) instructions have the same N value in the range 01 through 99. Direct jumps are usable only once each per program (i.e., N is 01 through 99 can be used only once each) and the instructions between the JUMP and JUMP END instructions are ignored; 00 may be used as many times as necessary, instructions between JMP 00 and the next JME 00 are treated as NOP, thus increasing cycle time, as compared with direct jumps.	<b>N:</b> 00 to 99 (not applicable for C□□P, C□□K, or C120 PCs)
<b>FAILURE ALARM</b> (@)FAL(06)		Assigns a failure alarm code to the given execution condition. When N can be given a value between 01 and 99 to indicate that a non-fatal error (i.e., one that will not stop the CPU) has occurred. This is indicated by the PC outputting N (the FAL number) to the FAL output area. To reset the FAL area, N can be defined as 00. This will cause all previously recorded FAL numbers in the FAL area to be deleted. FAL data sent after a 00 will be recorded in the normal way. The same code numbers can be used for both FAL(06) and FALS(07).	<b>N:</b> 00 to 99
<b>SEVERE FAILURE ALARM</b> FALS(07)		A fatal error is indicated by outputting N to the FAL output area and the CPU is stopped. The same FAL numbers are used for both FAL(06) and FALS(07).	<b>N:</b> 01 to 99
<b>STEP DEFINE</b> STEP(08)		When used with a control bit (B), defines the start of a new step and resets the previous step. When used without B, it defines the end of step execution.	<b>B:</b> IR HR AR LR
<b>STEP START</b> SNXT(09)		Used with a control bit (B) to indicate the end of the step, reset the step, and start the next step which has been defined with the same control bit.	<b>B:</b> IR HR AR LR

**Data Areas**

These footnote tables show the actual ranges of all data areas. Bit numbers are provided (except for DM and TC areas); remove the rightmost two digits for word numbers.

IR	SR	HR	TR	AR	LR	TC	DM	#
00000 to 23515	23600 to 25507	HR 0000 to 9915	TR 0 to 7	AR 0000 to 2715	LR 0000 to 6315	TC 000 to 511	Read/Wr: DM 0000 to DM 0999 Rd only: DM 1000 to DM 1999	0000 to 9999 or 0000 to FFFF

Name Mnemonic	Symbol	Function	Operand Data Areas
<b>SHIFT REGISTER</b> SFT(10)		Creates a bit shift register for data from the starting word (St) through to the ending word (E). I: input bit; P: shift pulse; R: reset input. St must be less than or equal to E. St and E must be in the same data area.	<b>St/E:</b> IR HR AR LR
<b>KEEP</b> KEEP(11)		Defines a bit (B) as a latch, controlled by the set (S) and reset (R) inputs.	<b>B:</b> IR HR AR LR
<b>REVERSIBLE COUNTER</b> CNTR (12)		Increases or decreases the PV by one whenever the increment input (II) or decrement input (DI) signals, respectively, go from OFF to ON. SV: 0 to 9999; R: reset input. Each TC bit can be used for one timer/counter only. The TC bit is entered as a constant.	<b>N:</b> TC <b>SV:</b> IR SR HR AR LR DM #
<b>DIFFERENTIATE UP</b> DIFU(13) <b>DIFFERENTIATE DOWN</b> DIFD(14)		DIFU(13) turns ON the designated bit (B) for one cycle on reception of the leading (rising) edge of the input signal; DIFD(14) turns ON the bit for one cycle on reception of the trailing (falling) edge.	<b>B:</b> IR HR AR LR
<b>HIGH-SPEED TIMER</b> TIMH(15)		A high-speed, ON-delay (decrementing) timer. SV: 00.02 to 99.99 s. Each TC bit can be assigned to only one timer or counter. The TC bit is entered as a constant.	<b>N:</b> TC <b>SV:</b> IR SR HR AR LR HR #
<b>WORD SHIFT</b> (@)WSFT(16)		The data in the words from the starting word (St) through to the ending word (E), is shifted left in word units, writing all zeros into the starting word. St must be less than or equal to E, and St and E must be in the same data area.	<b>St/E:</b> IR HR AR LR DM

**Data Areas**

These footnote tables show the actual ranges of all data areas. Bit numbers are provided (except for DM and TC areas); remove the rightmost two digits for word numbers.



IR	SR	HR	TR	AR	LR	TC	DM	#
00000 to 23515	23600 to 25507	HR 0000 to 9915	TR 0 to 7	AR 0000 to 2715	LR 0000 to 6315	TC 000 to 511	Read/Wr: DM 0000 to DM 0999 Rd only: DM 1000 to DM 1999	0000 to 9999 or 0000 to FFFF

Name Mnemonic	Symbol	Function	Operand Data Areas
<b>REVERSIBLE WORD SHIFT</b> (@)RWS(17) (CPU11)		Creates and controls a reversible non-synchronous word shift register between St and E. Exchanges the content of a word containing zero with the content of either the preceding or following word, depending on the shift direction. Bits 13, 14, and 15 of control word C determine the mode of operation of the register according to the following: The shift direction is determined by bit 13 (OFF shifts the non-zero data to higher addressed words; ON to lower addressed words). Bit 14 is the register enable bit (ON for shift enabled). Bit 15 is the reset bit (if bit 15 is ON, the register will be set to zero between St and E when the instruction is executed with bit 14 also ON). St and E must be in the same data area.	<b>C:</b> IR SR HR AR LR TC DM # <b>St/E:</b> IR SR HR AR LR TC DM
<b>CYCLE TIME</b> (@)SCAN(18) (CPU11)		Sets the minimum cycle time, Mi, in tenths of milliseconds. The possible setting range is from 0 to 999.0 ms. If the actual cycle time is less than the time set using SCAN(18), the CPU will wait until the designated time has elapsed before starting the next cycle.	<b>Mi:</b> IR SR HR AR LR TC DM # —: Not used.
<b>MULTI-WORD COMPARE</b> (@)MCMP(19) (CPU11)		Compares the data within a block of 16 words of 4-digit hexadecimal data (S <sub>1</sub> to S <sub>1</sub> +15) with that in another block of 16 words (S <sub>2</sub> to S <sub>2</sub> +15) on a word-by-word basis. If the words are not in agreement, the bit corresponding to unmatched words turns ON in the result word, D. Bits corresponding to words that are equal are turned OFF.	<b>S<sub>1</sub>/S<sub>2</sub>:</b> IR SR HR AR LR TC DM <b>D:</b> IR SR HR AR LR TC DM
<b>COMPARE</b> (@)CMP(20)		Compares the data in two 4-digit hexadecimal words (Cp1 and Cp2) and outputs result to the GR, EQ, or LE Flags.	<b>Cp1/Cp2:</b> IR SR HR AR LR TC DM #
<b>MOVE</b> (@)MOV(21)		Transfers data from source word, (S) to destination word (D).	<b>S:</b> IR SR HR AR LR TC DM # <b>D:</b> IR HR AR LR DM

**Data Areas**

These footnote tables show the actual ranges of all data areas. Bit numbers are provided (except for DM and TC areas); remove the rightmost two digits for word numbers.

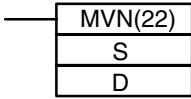
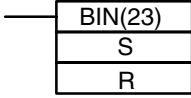
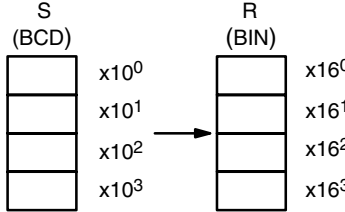
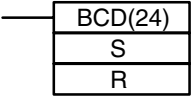
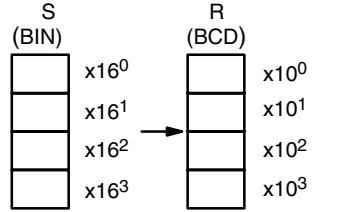
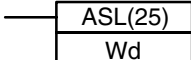
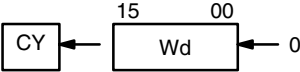
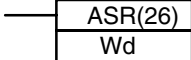
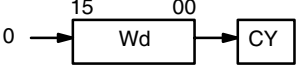
IR	SR	HR	TR	AR	LR	TC	DM	#
00000 to 23515	23600 to 25507	HR 0000 to 9915	TR 0 to 7	AR 0000 to 2715	LR 0000 to 6315	TC 000 to 511	Read/Wr: DM 0000 to DM 0999 Rd only: DM 1000 to DM 1999	0000 to 9999 or 0000 to FFFF

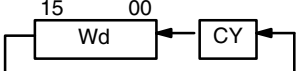
Name Mnemonic	Symbol	Function	Operand Data Areas
<b>MOVE NOT</b> (@)MVN(22)		Transfers the inverse of the data in the source word (S) to destination word (D).	<b>S:</b> IR SR HR AR LR TC DM # <b>D:</b> IR HR AR LR DM
<b>BCD-TO-BINARY</b> (@)BIN(23)		Converts 4-digit, BCD data in source word (S) into 16-bit binary data, and outputs converted data to result word (R).  	<b>S:</b> IR SR HR AR LR TC DM <b>R:</b> IR HR AR LR DM
<b>BINARY-TO-BCD</b> (@)BCD(24)		Converts binary data in source word (S) into BCD, and outputs converted data to result word (R).  	<b>S:</b> IR SR HR AR LR DM <b>R:</b> IR HR AR LR DM
<b>ARITHMETIC SHIFT LEFT</b> (@)ASL(25)		Each bit within a single word of data (Wd) is shifted one bit to the left, with zero written to bit 00 and bit 15 moving to CY.  	<b>Wd:</b> IR HR AR LR DM
<b>ARITHMETIC SHIFT RIGHT</b> (@)ASR(26)		Each bit within a single word of data (Wd) is shifted one bit to the right, with zero written to bit 15 and bit 00 moving to CY.  	<b>Wd:</b> IR HR AR LR DM
<b>ROTATE LEFT</b> (@)ROL(27)		Each bit within a single word of data (Wd) is moved one bit to the left, with bit 15 moving to carry (CY), and CY moving to bit 00.  	<b>Wd:</b> IR HR AR LR DM

**Data Areas**

These footnote tables show the actual ranges of all data areas. Bit numbers are provided (except for DM and TC areas); remove the rightmost two digits for word numbers.

IR	SR	HR	TR	AR	LR	TC	DM	#
00000 to 23515	23600 to 25507	HR 0000 to 9915	TR 0 to 7	AR 0000 to 2715	LR 0000 to 6315	TC 000 to 511	Read/Wr: DM 0000 to DM 0999 Rd only: DM 1000 to DM 1999	0000 to 9999 or 0000 to FFFF

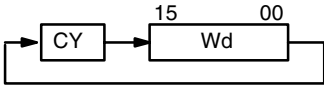
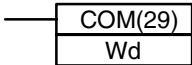
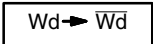
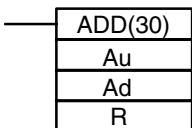
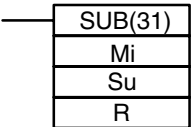
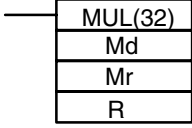
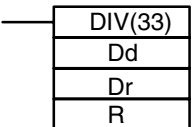
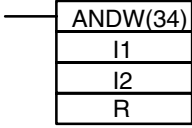
Name Mnemonic	Symbol	Function	Operand Data Areas
<b>ROTATE RIGHT</b> (@)ROR(28)		Each bit within a single word of data (Wd) is moved one bit to the right, with bit 00 moving to carry (CY), and CY moving to bit 15. 	<b>Wd:</b> IR HR AR LR DM
<b>COMPLEMENT</b> (@)COM(29)		Inverts bit status of one word (Wd) of data, changing 0s to 1s, and vice versa. 	<b>Wd:</b> IR HR AR LR DM
<b>BCD ADD</b> (@)ADD(30)		Adds two 4-digit BCD values (Au and Ad) and content of CY, and outputs the result to the specified result word (R). $Au + Ad + \text{CY} \rightarrow R \text{ CY}$	<b>Au/Ad:</b> IR SR HR AR LR TC DM # <b>R:</b> IR HR AR LR DM
<b>BCD SUBTRACT</b> (@)SUB(31)		Subtracts both the 4-digit BCD subtrahend (Su) and content of CY, from the 4-digit BCD minuend (Mi) and outputs the result to the specified result word (R). $Mi - Su - \text{CY} \rightarrow R \text{ CY}$	<b>Mi/Su:</b> IR SR HR AR LR TC DM # <b>R:</b> IR HR AR LR DM
<b>BCD MULTIPLY</b> (@)MUL(32)		Multiplies the 4-digit BCD multiplicand (Md) and 4-digit BCD multiplier (Mr), and outputs the result to the specified result words (R and R + 1). R and R + 1 must be in the same data area. $Md \times Mr \rightarrow R + 1 \quad R$	<b>Md/Mr:</b> IR SR HR AR LR TC DM # <b>R:</b> IR HR AR LR DM
<b>BCD DIVIDE</b> (@)DIV(33)		Divides the 4-digit BCD dividend (Dd) by the 4-digit BCD divisor (Dr), and outputs the result to the specified result words. R receives the quotient; R + 1 receives the remainder. R and R + 1 must be in the same data area. $Dd \div Dr \rightarrow R + 1 \quad R$	<b>Dd/Dr:</b> IR SR HR AR LR TC DM # <b>R:</b> IR HR AR LR DM
<b>LOGICAL AND</b> (@)ANDW(34)		Logically ANDs two 16-bit input words (I1 and I2) and sets the bits in the result word (R) if the corresponding bits in the input words are both ON.	<b>I1/I2:</b> IR SR HR AR LR TC DM # <b>R:</b> IR HR AR LR DM

**Data Areas**

These footnote tables show the actual ranges of all data areas. Bit numbers are provided (except for DM and TC areas); remove the rightmost two digits for word numbers.

IR	SR	HR	TR	AR	LR	TC	DM	#
00000 to 23515	23600 to 25507	HR 0000 to 9915	TR 0 to 7	AR 0000 to 2715	LR 0000 to 6315	TC 000 to 511	Read/Wr: DM 0000 to DM 0999 Rd only: DM 1000 to DM 1999	0000 to 9999 or 0000 to FFFF

Name Mnemonic	Symbol	Function	Operand Data Areas
<b>LOGICAL OR</b> (@)ORW(35)		Logically ORs two 16-bit input words (I1 and I2) and sets the bits in the result word (R) when one or both of the corresponding bits in the input words is/are ON.	<b>I1/I2:</b> IR SR HR AR LR TC DM # <b>R:</b> IR HR AR LR DM
<b>EXCLUSIVE OR</b> (@)XORW(36)		Exclusively ORs two 16-bit input words (I1 and I2) and sets the bits in the result word (R) when the corresponding bits in input words differ in status.	<b>I1/I2:</b> IR SR HR AR LR TC DM # <b>R:</b> IR HR AR LR DM
<b>EXCLUSIVE NOR</b> (@)XNRW(37)		Exclusively NORs two 16-bit input words (I1 and I2) and sets the bits in the result word (R) when the corresponding bits in both input words have the same status.	<b>I1/I2:</b> IR SR HR AR LR TC DM # <b>R:</b> IR HR AR LR DM
<b>INCREMENT</b> (@)INC(38)		Increments the value of a 4-digit BCD word (Wd) by one, without affecting carry (CY).	<b>Wd:</b> IR HR AR LR DM
<b>DECREMENT</b> (@)DEC(39)		Decrements the value of a 4-digit BCD word by 1, without affecting carry (CY).	<b>Wd:</b> IR HR AR LR DM
<b>SET CARRY</b> (@)STC(40)		Sets the Carry Flag (i.e., turns CY ON).	None
<b>CLEAR CARRY</b> (@)CLC(41)		Clears the Carry Flag (i.e., turns CY OFF).	None

**Data Areas**

These footnote tables show the actual ranges of all data areas. Bit numbers are provided (except for DM and TC areas); remove the rightmost two digits for word numbers.

IR	SR	HR	TR	AR	LR	TC	DM	#
00000 to 23515	23600 to 25507	HR 0000 to 9915	TR 0 to 7	AR 0000 to 2715	LR 0000 to 6315	TC 000 to 511	Read/Wr: DM 0000 to DM 0999 Rd only: DM 1000 to DM 1999	0000 to 9999 or 0000 to FFFF

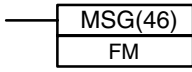
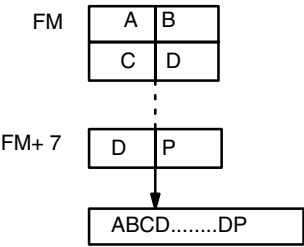
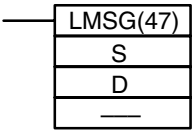
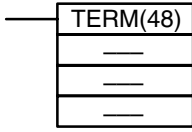
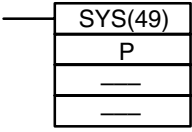

Name Mnemonic	Symbol	Function	Operand Data Areas
<b>DISPLAY MESSAGE</b> (@)MSG(46)		Displays eight words of ASCII code, starting from FM, on the Programming Console or GPC. All eight words must be in the same data area.  	<b>FM:</b> IR HR AR LR TC DM #
<b>LONG MESSAGE</b> (@)LMSG(47) (CPU11)		Outputs a 32-character message to either a Programming Console, or a device connected via the RS-232C interface. The output message must be in ASCII beginning at address S. The destination of the message is designated in D: 000 specifies that the message is to be output to the GPC; 001 specifies the RS-232C interface, starting with the leftmost byte; and 002 specifies the RS-232C interface, starting from the rightmost byte.	<b>S:</b> IR HR AR LR TC DM  <b>D:</b> #000 #001 #002  —: Not used.
<b>TERMINAL MODE</b> (@)TERM(48) (CPU11)		When the execution condition is ON, the Programming Console operation mode is changed to TERMINAL mode. There is no program command available to change the mode back to CONSOLE mode. Pressing the CHNG key on the Programming Console manually toggles between the two modes.	None
<b>SET SYSTEM</b> (@)SYS(49) (CPU11)		Used to either control certain operating parameters, or to execute the system commands that can be executed from the AR area. The contents of the leftmost 8 bits (i.e., bits 08 to 15) of P determine which function SYS(49) will have. If they contain A3, then bit 00 specifies whether the battery will be checked, and bit 07 specifies whether I/O status will be maintained on start up. Bit 06 specifies whether the Force Status Hold Bit is set. To be effective SYS(49) must be programmed at address 00001 with LD AR 1001 at address 00000.	<b>P:</b> #  —: Not used.

**Data Areas**

These footnote tables show the actual ranges of all data areas. Bit numbers are provided (except for DM and TC areas); remove the rightmost two digits for word numbers.

IR	SR	HR	TR	AR	LR	TC	DM	#
00000 to 23515	23600 to 25507	HR 0000 to 9915	TR 0 to 7	AR 0000 to 2715	LR 0000 to 6315	TC 000 to 511	Read/Wr: DM 0000 to DM 0999 Rd only: DM 1000 to DM 1999	0000 to 9999 or 0000 to FFFF

Name Mnemonic	Symbol	Function	Operand Data Areas
<b>BINARY ADD</b> (@)ADB(50)		<p>Adds the 4-digit augend (Au), 4-digit addend (Ad), and content of CY and outputs the result to the specified result word (R).</p> $  \begin{array}{r}  \text{Au} \\  + \text{Ad} \\  + \text{CY} \\  \hline  \text{R} \\  \text{CY}  \end{array}  $	<b>Au/Ad:</b> IR SR HR AR LR TC DM # <b>R:</b> IR HR AR LR DM
<b>BINARY SUBTRACT</b> (@)SBB(51)		<p>Subtracts the 4-digit hexadecimal subtrahend (Su) and content of carry, from the 4-digit hexadecimal minuend (Mi), and outputs the result to the specified result word (R).</p> $  \begin{array}{r}  \text{Mi} \\  - \text{Su} \\  - \text{CY} \\  \hline  \text{R} \\  \text{CY}  \end{array}  $	<b>Mi/Su:</b> IR SR HR AR LR TC DM # <b>R:</b> IR HR AR LR DM
<b>BINARY MULTIPLY</b> (@)MLB(52)		<p>Multiplies the 4-digit hexadecimal multiplicand (Md) and 4-digit multiplier (Mr), and outputs the 8-digit hexadecimal result to the specified result words (R and R+1). R and R+1 must be in the same data area.</p> $  \begin{array}{r}  \text{Md} \\  \times \text{Mr} \\  \hline  \text{Quotient } \text{R} \\  \text{Remainder } \text{R+1}  \end{array}  $	<b>Md/Mr:</b> IR SR HR AR LR TC DM # <b>R:</b> IR HR AR LR DM
<b>BINARY DIVIDE</b> (@)DVB(53)		<p>Divides the 4-digit hexadecimal dividend (Dd) by the 4-digit divisor (Dr), and outputs result to the designated result words ( R and R + 1). R and R + 1 must be in the same data area.</p> $  \begin{array}{r}  \text{Dd} \\  \div \text{Dr} \\  \hline  \text{Quotient } \text{R} \\  \text{Remainder } \text{R + 1}  \end{array}  $	<b>Dd/Dr:</b> IR SR HR AR LR TC DM # <b>R:</b> IR HR AR LR

**Data Areas**

These footnote tables show the actual ranges of all data areas. Bit numbers are provided (except for DM and TC areas); remove the rightmost two digits for word numbers.

IR	SR	HR	TR	AR	LR	TC	DM	#
00000 to 23515	23600 to 25507	HR 0000 to 9915	TR 0 to 7	AR 0000 to 2715	LR 0000 to 6315	TC 000 to 511	Read/Wr: DM 0000 to DM 0999 Rd only: DM 1000 to DM 1999	0000 to 9999 or 0000 to FFFF

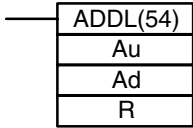
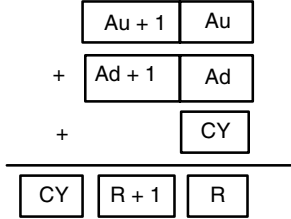
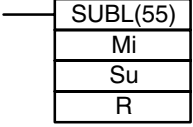
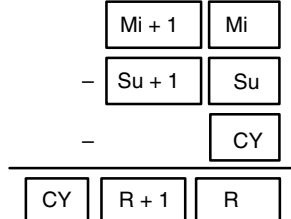
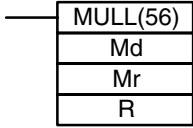
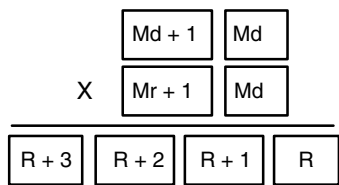
Name Mnemonic	Symbol	Function	Operand Data Areas
<b>DOUBLE BCD ADD</b> (@)ADDL(54)		Adds two 8-digit values (2 words each) and the content of CY, and outputs the result to the specified result words. All words for any one operand must be in the same data area.  	<b>Au/Ad: R:</b> IR IR SR HR HR AR AR LR LR DM TC DM
<b>DOUBLE BCD SUBTRACT</b> (@)SUBL(55)		Subtracts both the 8-digit BCD subtrahend and the content of CY from an 8-digit BCD minuend, and outputs the result to the specified result words. All words for any one operand must be in the same data area.  	<b>Mi/Su: R:</b> IR IR SR HR HR AR AR LR LR DM TC DM
<b>DOUBLE BCD MULTIPLY</b> (@)MULL(56)		Multiplies the 8-digit BCD multiplicand and 8-digit BCD multiplier, and outputs the result to the specified result words. All words for any one operand must be in the same data area.  	<b>Md/Mr: R:</b> IR IR SR HR HR AR AR LR LR DM TC DM

**Data Areas**

These footnote tables show the actual ranges of all data areas. Bit numbers are provided (except for DM and TC areas); remove the rightmost two digits for word numbers.

IR	SR	HR	TR	AR	LR	TC	DM	#
00000 to 23515	23600 to 25507	HR 0000 to 9915	TR 0 to 7	AR 0000 to 2715	LR 0000 to 6315	TC 000 to 511	Read/Wr: DM 0000 to DM 0999 Rd only: DM 1000 to DM 1999	0000 to 9999 or 0000 to FFFF

Name Mnemonic	Symbol	Function	Operand Data Areas
<b>DOUBLE BCD DIVIDE</b> (@)DIVL(57)		<p>Divides the 8-digit BCD dividend by an 8-digit BCD divisor, and outputs the result to the specified result words. All words for any one operand must be in the same data area.</p>	<b>Dd/Dr:</b> IR SR HR AR LR TC DM  <b>R:</b> IR HR AR LR DM
<b>DOUBLE BCD-TO-DOUBLE BINARY</b> (@)BINL(58)		<p>Converts the BCD value of the two source words (S: starting word) into binary and outputs the converted data to the two result words (R: starting word). All words for any one operand must be in the same data area.</p>	<b>S:</b> IR SR HR AR LR TC DM  <b>R:</b> IR HR AR LR DM
<b>DOUBLE BINARY-TO-DOUBLE BCD</b> (@)BCDL(59)		<p>Converts the binary value of the two source words (S: starting word) into eight digits of BCD data, and outputs the converted data to the two result words (R: starting result word). Both words for any one operand must be in the same data area.</p>	<b>S:</b> IR SR HR AR LR DM  <b>R:</b> IR HR AR LR DM
<b>DOUBLE COMPARE</b> CMPL(60) (CPU11)		<p>Compares the 8-digit hexadecimal values in words S<sub>1</sub>+1 and S<sub>1</sub> with the values in S<sub>2</sub>+1 and S<sub>2</sub>, and indicates the result using the Greater Than, Less Than, and Equal Flags in the AR area. S<sub>1</sub>+1 and S<sub>2</sub>+1 are regarded as the most significant data in each pair of words.</p>	<b>S<sub>1</sub>,S<sub>2</sub>:</b> IR SR HR AR LR TC DM

**Data Areas**

These footnote tables show the actual ranges of all data areas. Bit numbers are provided (except for DM and TC areas); remove the rightmost two digits for word numbers.

IR	SR	HR	TR	AR	LR	TC	DM	#
00000 to 23515	23600 to 25507	HR 0000 to 9915	TR 0 to 7	AR 0000 to 2715	LR 0000 to 6315	TC 000 to 511	Read/Wr: DM 0000 to DM 0999 Rd only: DM 1000 to DM 1999	0000 to 9999 or 0000 to FFFF

Name Mnemonic	Symbol	Function	Operand Data Areas
<b>COLUMN-TO-WORD</b> (@)CTW(63) (CPU11)		Fetches data from the same numbered bit (C) in 16 consecutive words (where S is the address of the first source word), and creates a 4-digit word by consecutively placing the data in the bits of the destination word, D. The bit from word S is placed into bit 00 of D, the bit from word S+1 is placed into bit 01, etc.	<b>S:</b> IR, SR, HR, AR, LR, TC, DM <b>C:</b> IR, SR, HR, AR, LR, TC, DM <b>D:</b> IR, SR, HR, AR, LR, TC, DM, #
<b>WORD-TO-COLUMN</b> (@)WTC(64) (CPU11)		Places bit data from the source word (S), consecutively into the same numbered bits of the 16 consecutive destination words (where D is the address of the first destination word). Bit 00 from word S is placed into bit C of word D, bit 01 from word S is placed into bit C of word D+1, etc.	<b>S:</b> IR, SR, HR, AR, LR, TC, DM <b>D:</b> IR, SR, HR, AR, LR, TC, DM <b>C:</b> IR, SR, HR, AR, LR, TC, DM, #
<b>HOURS-TO-SECONDS</b> (@)HTS(65) (CPU11)		Converts a time given in hours/minutes/seconds (S and S+1) to an equivalent time in seconds only (R and R+1). S and S+1 must be BCD and within one data area. R and R+1 must also be within one data area.	<b>S:</b> IR, SR, HR, AR, LR, TC, DM <b>R:</b> IR, SR, HR, AR, LR, TC, DM —: Not used.
<b>SECONDS-TO-HOURS</b> (@)STH(66) (CPU11)		Converts a time given in seconds (S and S+1) to an equivalent time in hours/minutes/seconds (R and R+1). S and S+1 must be BCD between 0 and 35,999,999, and within the same data area. R and R+1 must also be within one data area.	<b>S:</b> IR, SR, HR, AR, LR, TC, DM <b>R:</b> IR, SR, HR, AR, LR, TC, DM —: Not used.

**Data Areas**

These footnote tables show the actual ranges of all data areas. Bit numbers are provided (except for DM and TC areas); remove the rightmost two digits for word numbers.

IR	SR	HR	TR	AR	LR	TC	DM	#
00000 to 23515	23600 to 25507	HR 0000 to 9915	TR 0 to 7	AR 0000 to 2715	LR 0000 to 6315	TC 000 to 511	Read/Wr: DM 0000 to DM 0999 Rd only: DM 1000 to DM 1999	0000 to 9999 or 0000 to FFFF

Name Mnemonic	Symbol	Function	Operand Data Areas
<b>BIT COUNTER</b> (@)BCNT(67)		Counts the number of ON bits in one or more words (SB is the beginning source word) and outputs the result to the specified result word (R). N gives the number of words to be counted. All words in which bit are to be counted must be in the same data area.	<b>N:</b> IR, SR, HR, AR, LR, TC, DM <b>R:</b> IR, HR, AR, LR, TC, DM <b>SB:</b> IR, SR, HR, AR, LR, TC, DM
<b>BLOCK COMPARE</b> (@)BCMP(68)		Compares a 1-word binary value (S) with the 16 ranges given in the comparison table (CB is the starting word of the comparison block). If the value falls within any of the ranges, the corresponding bits in the result word (R) will be set. The comparison block must be within one data area.  <p style="text-align: center;">Lower limit ≤ S ≤ Upper limit → 1</p>	<b>S:</b> IR, SR, HR, AR, LR, TC, DM, # <b>CB:</b> IR, SR, HR, AR, LR, TC, DM <b>R:</b> IR, HR, AR, LR, TC, DM

**Data Areas**

These footnote tables show the actual ranges of all data areas. Bit numbers are provided (except for DM and TC areas); remove the rightmost two digits for word numbers.

IR	SR	HR	TR	AR	LR	TC	DM	#
00000 to 23515	23600 to 25507	HR 0000 to 9915	TR 0 to 7	AR 0000 to 2715	LR 0000 to 6315	TC 000 to 511	Read/Wr: DM 0000 to DM 0999 Rd only: DM 1000 to DM 1999	0000 to 9999 or 0000 to FFFF

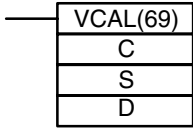
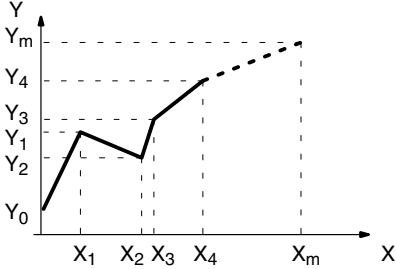
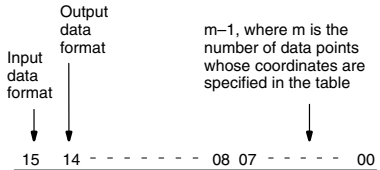
Name Mnemonic	Symbol	Function	Operand Data Areas																																																																		
<p><b>VALUE CALCULATE</b> (@)VCAL(69) (CPU11)</p>		<p>Calculates the cosine, or sine of the given degree value, or determines the y-coordinate of the given x value in a previously established line graph. For the sine and cosine conversions, S is entered in BCD as an angle (in the range 0.0 to 90.0 degrees). When calculating the y-coordinate in a graph, S gives the address of the value of the x-coordinate. The calculated data is transferred to the destination word (D). Sine and cosine results are given in BCD. Line graph coordinate calculations (interpolation) can be in BCD or BIN.</p> <p>The data in the control word (C) determines which operation is performed. If C is entered as a constant with a value of 0000 or 0001, the sine or cosine, respectively, of the source data value is calculated. If C is entered as a word designation, it gives the address of the first word of the data table for the line graph. The value of the first two digits gives m-1, where m is the number of data points for which coordinates are given on the line graph. Bits 14 and 15, respectively, specify the output and input data formats (0 indicates BCD, 1 indicates binary).</p>   <table border="1" data-bbox="756 1381 1198 1801"> <tr> <td>C</td> <td>15</td> <td>14</td> <td>08</td> <td>07</td> <td>00</td> </tr> <tr> <td></td> <td colspan="5">000000</td> </tr> <tr> <td>C+1</td> <td colspan="5">X<sub>m</sub> (max. x-coordinate for this table)</td> </tr> <tr> <td>C+2</td> <td colspan="5">Y<sub>0</sub></td> </tr> <tr> <td>C+3</td> <td colspan="5">X<sub>1</sub></td> </tr> <tr> <td>C+4</td> <td colspan="5">Y<sub>1</sub></td> </tr> <tr> <td>C+5</td> <td colspan="5">X<sub>2</sub></td> </tr> <tr> <td>C+6</td> <td colspan="5">Y<sub>2</sub></td> </tr> <tr> <td>...</td> <td colspan="5">...</td> </tr> <tr> <td>C+(2m+1)</td> <td colspan="5">X<sub>m</sub></td> </tr> <tr> <td>C+(2m+2)</td> <td colspan="5">Y<sub>m</sub></td> </tr> </table>	C	15	14	08	07	00		000000					C+1	X <sub>m</sub> (max. x-coordinate for this table)					C+2	Y <sub>0</sub>					C+3	X <sub>1</sub>					C+4	Y <sub>1</sub>					C+5	X <sub>2</sub>					C+6	Y <sub>2</sub>					...	...					C+(2m+1)	X <sub>m</sub>					C+(2m+2)	Y <sub>m</sub>					<p><b>C:</b> IR SR HR AR LR TC DM # <b>S:</b> IR SR HR AR LR TC DM <b>D:</b> IR SR HR AR LR TC DM</p>
C	15	14	08	07	00																																																																
	000000																																																																				
C+1	X <sub>m</sub> (max. x-coordinate for this table)																																																																				
C+2	Y <sub>0</sub>																																																																				
C+3	X <sub>1</sub>																																																																				
C+4	Y <sub>1</sub>																																																																				
C+5	X <sub>2</sub>																																																																				
C+6	Y <sub>2</sub>																																																																				
...	...																																																																				
C+(2m+1)	X <sub>m</sub>																																																																				
C+(2m+2)	Y <sub>m</sub>																																																																				

**Data Areas**

These footnote tables show the actual ranges of all data areas. Bit numbers are provided (except for DM and TC areas); remove the rightmost two digits for word numbers.

IR	SR	HR	TR	AR	LR	TC	DM	#
00000 to 23515	23600 to 25507	HR 0000 to 9915	TR 0 to 7	AR 0000 to 2715	LR 0000 to 6315	TC 000 to 511	Read/Wr: DM 0000 to DM 0999 Rd only: DM 1000 to DM 1999	0000 to 9999 or 0000 to FFFF

Name Mnemonic	Symbol	Function	Operand Data Areas																											
<b>BLOCK TRANSFER</b> (@)XFER(70)		<p>Moves the content of several consecutive source words (S gives the address of the starting source word) to consecutive destination words (D is the starting destination word). All source words must be in the same data area, as must all destination words. Transfers can be within one data area or between two data areas, but the source and destination words must not overlap.</p>	<table> <tr> <td><b>N:</b></td> <td><b>S :</b></td> <td><b>D:</b></td> </tr> <tr> <td>IR</td> <td>IR</td> <td>IR</td> </tr> <tr> <td>SR</td> <td>HR</td> <td>SR</td> </tr> <tr> <td>HR</td> <td>AR</td> <td>HR</td> </tr> <tr> <td>AR</td> <td>LR</td> <td>AR</td> </tr> <tr> <td>LR</td> <td>TC</td> <td>LR</td> </tr> <tr> <td>TC</td> <td>DM</td> <td>TC</td> </tr> <tr> <td>DM</td> <td></td> <td>DM</td> </tr> <tr> <td>#</td> <td></td> <td>#</td> </tr> </table>	<b>N:</b>	<b>S :</b>	<b>D:</b>	IR	IR	IR	SR	HR	SR	HR	AR	HR	AR	LR	AR	LR	TC	LR	TC	DM	TC	DM		DM	#		#
<b>N:</b>	<b>S :</b>	<b>D:</b>																												
IR	IR	IR																												
SR	HR	SR																												
HR	AR	HR																												
AR	LR	AR																												
LR	TC	LR																												
TC	DM	TC																												
DM		DM																												
#		#																												
<b>BLOCK SET</b> (@)BSET(71)		<p>Copies the content of one word or constant (S) to several consecutive words (from the starting word, St, through to the ending word, E). St and E must be in the same data area.</p>	<table> <tr> <td><b>St/E:</b></td> <td><b>S:</b></td> </tr> <tr> <td>IR</td> <td>IR</td> </tr> <tr> <td>HR</td> <td>SR</td> </tr> <tr> <td>AR</td> <td>HR</td> </tr> <tr> <td>LR</td> <td>AR</td> </tr> <tr> <td>TC</td> <td>LR</td> </tr> <tr> <td>DM</td> <td>TC</td> </tr> <tr> <td></td> <td>DM</td> </tr> <tr> <td></td> <td>#</td> </tr> </table>	<b>St/E:</b>	<b>S:</b>	IR	IR	HR	SR	AR	HR	LR	AR	TC	LR	DM	TC		DM		#									
<b>St/E:</b>	<b>S:</b>																													
IR	IR																													
HR	SR																													
AR	HR																													
LR	AR																													
TC	LR																													
DM	TC																													
	DM																													
	#																													
<b>SQUARE ROOT</b> (@)ROOT(72)		<p>Computes the square root of an 8-digit BCD value (Sq and Sq + 1) and outputs the truncated 4-digit, integer result to the specified result word (R). Sq and Sq + 1 must be in the same data area.</p>	<table> <tr> <td><b>Sq:</b></td> <td><b>R:</b></td> </tr> <tr> <td>IR</td> <td>IR</td> </tr> <tr> <td>SR</td> <td>HR</td> </tr> <tr> <td>HR</td> <td>AR</td> </tr> <tr> <td>AR</td> <td>LR</td> </tr> <tr> <td>LR</td> <td>DM</td> </tr> <tr> <td>TC</td> <td></td> </tr> <tr> <td>DM</td> <td></td> </tr> </table>	<b>Sq:</b>	<b>R:</b>	IR	IR	SR	HR	HR	AR	AR	LR	LR	DM	TC		DM												
<b>Sq:</b>	<b>R:</b>																													
IR	IR																													
SR	HR																													
HR	AR																													
AR	LR																													
LR	DM																													
TC																														
DM																														
<b>DATA EXCHANGE</b> (@)XCHG(73)		<p>Exchanges the contents of two words (E1 and E2).</p>	<table> <tr> <td><b>E1/E2:</b></td> </tr> <tr> <td>IR</td> </tr> <tr> <td>HR</td> </tr> <tr> <td>AR</td> </tr> <tr> <td>LR</td> </tr> <tr> <td>TC</td> </tr> <tr> <td>DM</td> </tr> </table>	<b>E1/E2:</b>	IR	HR	AR	LR	TC	DM																				
<b>E1/E2:</b>																														
IR																														
HR																														
AR																														
LR																														
TC																														
DM																														

**Data Areas**

These footnote tables show the actual ranges of all data areas. Bit numbers are provided (except for DM and TC areas); remove the rightmost two digits for word numbers.

IR	SR	HR	TR	AR	LR	TC	DM	#
00000 to 23515	23600 to 25507	HR 0000 to 9915	TR 0 to 7	AR 0000 to 2715	LR 0000 to 6315	TC 000 to 511	Read/Wr: DM 0000 to DM 0999 Rd only: DM 1000 to DM 1999	0000 to 9999 or 0000 to FFFF



Name Mnemonic	Symbol	Function	Operand Data Areas
<b>ONE DIGIT SHIFT LEFT</b> (@)SLD(74)		<p>Shifts all data, between the starting word (St) and ending word (E), one digit (four bits) to the left, writing zero into the rightmost digit of the starting word. St and E must be in the same data area.</p>	<b>St/E:</b> IR HR AR LR DM
<b>ONE DIGIT SHIFT RIGHT</b> (@)SRD(75)		<p>Shifts all data, between starting word (St) and ending word (E), one digit (four bits) to the right, writing zero into the leftmost digit of the ending word. St and E must be in the same data area.</p>	<b>St/E:</b> IR HR AR LR DM
<b>4-TO-16 DECODER</b> (@)MLPX(76)		<p>Converts up to four hexadecimal digits in the source word (S), into decimal values from 0 to 15, and turns ON the corresponding bit(s) in the result word(s) (R). There is one result word for each converted digit. Digits to be converted are designated by Di. (The rightmost digit specifies the first digit. The next digit to the left gives the number of digits to be converted minus 1. The two leftmost digits are not used.)</p>	<b>S:</b> IR SR HR AR LR TC DM  <b>Di:</b> IR HR AR LR TC DM #  <b>R:</b> IR HR AR LR TC DM
<b>16-TO-4 ENCODER</b> (@)DMPX(77)		<p>Determines the position of the leftmost ON bit in the source word(s) (starting word: S) and turns ON the corresponding bit(s) in the specified digit of the result word (R). One digit is used for each source word. Digits to receive the converted values are designated by Di. (The rightmost digit specifies the first digit. The next digit to left gives the number of words to be converted minus 1. The two leftmost digits are not used.)</p>	<b>S:</b> IR SR HR AR LR TC DM  <b>R:</b> IR HR AR LR DM  <b>Di:</b> IR HR AR LR TC DM #

**Data Areas**

These footnote tables show the actual ranges of all data areas. Bit numbers are provided (except for DM and TC areas); remove the rightmost two digits for word numbers.

IR	SR	HR	TR	AR	LR	TC	DM	#
00000 to 23515	23600 to 25507	HR 0000 to 9915	TR 0 to 7	AR 0000 to 2715	LR 0000 to 6315	TC 000 to 511	Read/Wr: DM 0000 to DM 0999 Rd only: DM 1000 to DM 1999	0000 to 9999 or 0000 to FFFF

Name Mnemonic	Symbol	Function	Operand Data Areas
<b>7-SEGMENT DECODER</b> (@)SDEC(78)		<p>Converts hexadecimal values from the source word (S) into 7-segment display data. Results are placed in consecutive half-words, starting at the first destination word (D). Di gives digit and destination details. (The rightmost digit gives the first digit to be converted. The next digit to the left gives the number of digits to be converted minus 1. If the next digit is 1, the first converted data is transferred to left half of the first destination word. If it is 0, the transfer is to the right half).</p>	<p><b>S:</b> IR SR HR AR LR TC DM</p> <p><b>Di:</b> IR HR AR LR TC DM #</p> <p><b>D:</b> IR HR AR LR DM</p>
<b>FLOATING POINT DIVIDE</b> (@)FDIV(79)		<p>Divides one floating point value by another and outputs a floating point result. The rightmost seven digits of each set of two words (eight digits) are used for mantissa, and the leftmost digit is used for the exponent and its sign (Bits 12 to 14 give the exponent value, 0 to 7. If bit 15 is 0, the exponent is positive; if it's 1, the exponent is negative).</p>	<p><b>Dd/Dr:</b> IR SR HR AR LR TC DM</p> <p><b>R:</b> IR HR AR LR DM</p>
<b>SINGLE WORD DISTRIBUTE</b> (@)DIST(80)		<p>Moves one word of source data (S) to the destination word whose address is given by the destination base word (DBs) plus offset (Of).</p>	<p><b>S:</b> IR SR HR AR LR TC DM #</p> <p><b>DBs:</b> IR HR AR LR TC DM #</p> <p><b>Of:</b> IR HR AR LR TC DM #</p>

**Data Areas**

These footnote tables show the actual ranges of all data areas. Bit numbers are provided (except for DM and TC areas); remove the rightmost two digits for word numbers.

IR	SR	HR	TR	AR	LR	TC	DM	#
00000 to 23515	23600 to 25507	HR 0000 to 9915	TR 0 to 7	AR 0000 to 2715	LR 0000 to 6315	TC 000 to 511	Read/Wr: DM 0000 to DM 0999 Rd only: DM 1000 to DM 1999	0000 to 9999 or 0000 to FFFF

Name Mnemonic	Symbol	Function	Operand Data Areas
<b>DATA COLLECT</b> (@)COLL(81)		<p>Extracts data from the source word and writes it to the destination word (D). The source word is determined by adding the offset (Of) to the address of the source base word (SBs).</p>	<p><b>SBs:</b> IR, SR, HR, AR, LR, TC, DM, #</p> <p><b>Of:</b> IR, HR, AR, LR, TC, DM, #</p> <p><b>D:</b> IR, HR, AR, LR, TC, DM, #</p>
<b>MOVE BIT</b> (@)MOVB(82)		<p>Transfers the designated bit of the source word or constant (S) to the designated bit of the destination word (D). The rightmost two digits of the bit designator (Bi) specify the source bit. The two leftmost digits specify the destination bit.</p>	<p><b>S:</b> IR, SR, HR, AR, LR, DM, #</p> <p><b>Bi:</b> IR, HR, AR, LR, TC, DM, #</p> <p><b>D:</b> IR, HR, AR, LR, TC, DM, #</p>
<b>MOVE DIGIT</b> (@)MOVD(83)		<p>Moves hexadecimal content of up to four specified 4-bit source digit(s) from the source word to the specified destination digit(s) (S gives the source word address, D specifies the destination word). Specific digits within the source and destination words are defined by the Digit Designator (Di) digits. (The rightmost digit gives the first source digit. The next digit to the left gives the number of digits to be moved. The next digit specifies the first digit in the destination word.)</p>	<p><b>S:</b> IR, SR, HR, AR, LR, TC, DM, #</p> <p><b>Di:</b> IR, HR, AR, LR, TC, DM, #</p> <p><b>D:</b> IR, SR, HR, AR, LR, TC, DM, #</p>

**Data Areas**

These footnote tables show the actual ranges of all data areas. Bit numbers are provided (except for DM and TC areas); remove the rightmost two digits for word numbers.

IR	SR	HR	TR	AR	LR	TC	DM	#
00000 to 23515	23600 to 25507	HR 0000 to 9915	TR 0 to 7	AR 0000 to 2715	LR 0000 to 6315	TC 000 to 511	Read/Wr: DM 0000 to DM 0999 Rd only: DM 1000 to DM 1999	0000 to 9999 or 0000 to FFFF

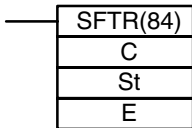
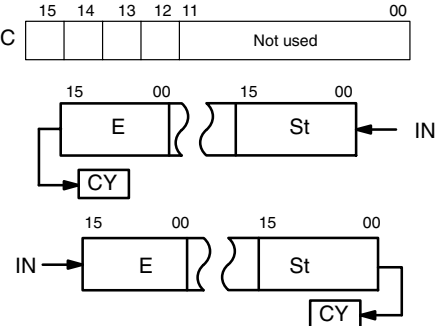
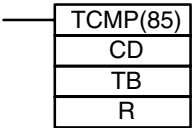
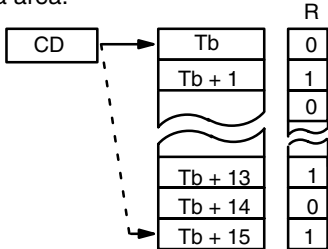
Name Mnemonic	Symbol	Function	Operand Data Areas
<b>REVERSIBLE SHIFT REGISTER</b> (@)SFTR(84)		<p>Shifts bits in the specified word or series of words either left or right. Starting (St) and ending words (E) must be specified. Control word (C) contains shift direction, reset input, and data input. (Bit 12: 0 = shift right, 1 = shift left. Bit 13 is the value shifted into the source data, with the bit at the opposite end being moved to CY. Bit 14: 1 = shift enabled, 0 = shift disabled. If bit 15 is ON when SFTR(89) is executed with an ON condition, the entire shift register and CY will be set to zero.) St and E must be in the same data area and St must be less than or equal to E.</p> 	<b>St/E/C:</b> IR HR AR TC LR DM
<b>TABLE COMPARE</b> (@)TCMP(85)		<p>Compares a 4-digit hexadecimal value (CD) with values in table consisting of 16 words (TB: is the first word of the comparison table). If the value of CD falls within any of the comparison ranges, corresponding bits in result word (R) are set (1 for agreement, and 0 for disagreement). The table must be entirely within the one data area.</p>  <p>1: agreement                      0: disagreement</p>	<b>CD: TB/R:</b> IR SR HR AR LR LR TC DM #

**Data Areas**

These footnote tables show the actual ranges of all data areas. Bit numbers are provided (except for DM and TC areas); remove the rightmost two digits for word numbers.

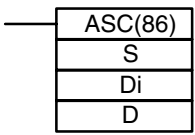
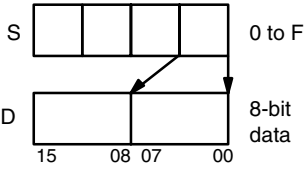
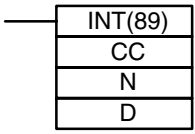

IR	SR	HR	TR	AR	LR	TC	DM	#
00000 to 23515	23600 to 25507	HR 0000 to 9915	TR 0 to 7	AR 0000 to 2715	LR 0000 to 6315	TC 000 to 511	Read/Wr: DM 0000 to DM 0999 Rd only: DM 1000 to DM 1999	0000 to 9999 or 0000 to FFFF

Name Mnemonic	Symbol	Function	Operand Data Areas												
<b>ASCII CONVERT</b> (@)ASC(86)		Converts hexadecimal digits from the source word (S) into 8-bit ASCII values, starting at leftmost or rightmost half of the starting destination word (D). The rightmost digit of Di designates the first source digit. The next digit to the left gives the number of digits to be converted. The next digit specifies the whether the data is to be transferred to the rightmost (0) or leftmost (1) half of the first destination word. The leftmost digit specifies parity: 0: none, 1: even, or 2: odd. 	<b>S:</b> IR SR HR LR TC DM  <b>Di:</b> IR HR LR TC DM #  <b>D:</b> IR HR LR TC DM #												
<b>INTERRUPT CONTROL</b> (@)INT(89)		Controls programmed (scheduled) interrupts and interrupts from Interrupt Input Units. Each PC can have up to 4 IIUs. N defines the source of the interrupt: 000 to 003 designate the no. of the IIU; 004 designates a scheduled interrupt. In IIUs, bits 00 to 07 identify the interrupting subroutine, higher bits are not used. Bit 00 of Unit 0 corresponds to interrupt subroutine 00, through to bit 07 of Unit 3 which corresponds to subroutine 31. CC is the control code, the meaning of which depends on the value of N, as follows: <table border="1" data-bbox="760 1255 1192 1822"> <thead> <tr> <th>CC</th> <th>N = 000 to 003</th> <th>N = 004</th> </tr> </thead> <tbody> <tr> <td>000</td> <td>Masks and unmask interrupt bits for the designated Unit (N) according to the data in D. Bits corresponding to ON bits in D are masked, those corresponding to OFF bits are unmasked. Masked bits are recorded and will be executed when they are unmasked (unless previously cleared).</td> <td>The interrupt time interval is set according to the data in D (00.01 to 99.99 s) The decimal point is not entered. The interrupt is cancelled if D is 00.00.</td> </tr> <tr> <td>001</td> <td>Clears the masked interrupt bits of the designated Unit (N) according to the corresponding ON bits in D. The subroutines corresponding to bits cleared in this manner will not be executed when the bit is unmasked.</td> <td>The time to the first interrupt is set according to the data in D (00.01 to 99.99 s) The decimal point is not entered. The interrupt is cancelled if D is 00.00.</td> </tr> <tr> <td>002</td> <td>Copies the mask status of the designated IIU to D.</td> <td>Copies the time interval data to D.</td> </tr> </tbody> </table>	CC	N = 000 to 003	N = 004	000	Masks and unmask interrupt bits for the designated Unit (N) according to the data in D. Bits corresponding to ON bits in D are masked, those corresponding to OFF bits are unmasked. Masked bits are recorded and will be executed when they are unmasked (unless previously cleared).	The interrupt time interval is set according to the data in D (00.01 to 99.99 s) The decimal point is not entered. The interrupt is cancelled if D is 00.00.	001	Clears the masked interrupt bits of the designated Unit (N) according to the corresponding ON bits in D. The subroutines corresponding to bits cleared in this manner will not be executed when the bit is unmasked.	The time to the first interrupt is set according to the data in D (00.01 to 99.99 s) The decimal point is not entered. The interrupt is cancelled if D is 00.00.	002	Copies the mask status of the designated IIU to D.	Copies the time interval data to D.	<b>CC:</b> 000 to 002  <b>N:</b> 000 to 004  <b>D:</b> IR HR AR LR TC DM #
CC	N = 000 to 003	N = 004													
000	Masks and unmask interrupt bits for the designated Unit (N) according to the data in D. Bits corresponding to ON bits in D are masked, those corresponding to OFF bits are unmasked. Masked bits are recorded and will be executed when they are unmasked (unless previously cleared).	The interrupt time interval is set according to the data in D (00.01 to 99.99 s) The decimal point is not entered. The interrupt is cancelled if D is 00.00.													
001	Clears the masked interrupt bits of the designated Unit (N) according to the corresponding ON bits in D. The subroutines corresponding to bits cleared in this manner will not be executed when the bit is unmasked.	The time to the first interrupt is set according to the data in D (00.01 to 99.99 s) The decimal point is not entered. The interrupt is cancelled if D is 00.00.													
002	Copies the mask status of the designated IIU to D.	Copies the time interval data to D.													

**Data Areas**

These footnote tables show the actual ranges of all data areas. Bit numbers are provided (except for DM and TC areas); remove the rightmost two digits for word numbers.

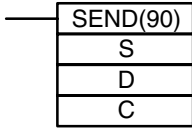
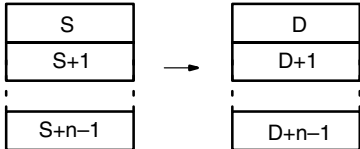
IR	SR	HR	TR	AR	LR	TC	DM	#
00000 to 23515	23600 to 25507	HR 0000 to 9915	TR 0 to 7	AR 0000 to 2715	LR 0000 to 6315	TC 000 to 511	Read/Wr: DM 0000 to DM 0999 Rd only: DM 1000 to DM 1999	0000 to 9999 or 0000 to FFFF

Name Mnemonic	Symbol	Function	Operand Data Areas																								
<b>NETWORK SEND</b> (@)SEND(90) (CPU11)		<p>Transfers data from n source words (S is the starting word) to the destination words (D is the first address) in node N of the specified network (in a SYSMAC LINK or NET Link System). The format of the control words varies depending on the type of system. In both types of systems, the first control word (C) gives the number of words to be transferred.</p> <p>For NET Link Systems, in word C+1, bit 14 specifies the system (0 for system 1, and 1 for system 0), and the rightmost 7 bits define the network number. The left half of word C+2 specifies the destination port (00: NSB, 01/02: NSU), and the right half specifies the destination node number. If the destination node number is set to 0, data is transmitted to all nodes.</p> <p>For SYSMAC LINK Systems, the right half of C+1 specifies the response monitoring time (default 00: 2 s, FF: monitoring disabled), the next digit to the left gives the maximum number of re-transmissions (0 to 15) that the PC will attempt if no response signal is received. Bit 13 specifies whether a response is needed (0) or not (1), and bit 14 specifies the system number (0 for system 1, and 1 for system 0). The right half of C+2 gives the destination node number. If this is set to 0, the data will be sent to all nodes.</p> <p><b>NET Link</b></p> <table border="1" data-bbox="764 1087 1187 1213"> <tr> <td>C</td> <td colspan="3">n: no. of words to be transmitted (0 to 1000)</td> </tr> <tr> <td>C+1</td> <td>0X00</td> <td>0000</td> <td>Network no. (0 to 127)</td> </tr> <tr> <td>C+2</td> <td colspan="2">Destination port no.</td> <td>Destination node no. (0 to 126)</td> </tr> </table> <p><b>SYSMAC LINK</b></p> <table border="1" data-bbox="764 1276 1187 1423"> <tr> <td>C</td> <td colspan="3">n: no. of words to be transmitted, 0 to 1000</td> </tr> <tr> <td>C+1</td> <td>0XX0</td> <td>Re-transmissions</td> <td>Response monitor time (0.1 to 25.4 s)</td> </tr> <tr> <td>C+2</td> <td>0000</td> <td>0000</td> <td>Destination node no. (0 to 62)</td> </tr> </table> <p style="text-align: center;">Source N                      Destination node N</p> 	C	n: no. of words to be transmitted (0 to 1000)			C+1	0X00	0000	Network no. (0 to 127)	C+2	Destination port no.		Destination node no. (0 to 126)	C	n: no. of words to be transmitted, 0 to 1000			C+1	0XX0	Re-transmissions	Response monitor time (0.1 to 25.4 s)	C+2	0000	0000	Destination node no. (0 to 62)	<p><b>S:</b> IR, SR, HR, AR, LR, TC, DM</p> <p><b>D/C:</b> IR, HR, AR, LR, TC, DM</p>
C	n: no. of words to be transmitted (0 to 1000)																										
C+1	0X00	0000	Network no. (0 to 127)																								
C+2	Destination port no.		Destination node no. (0 to 126)																								
C	n: no. of words to be transmitted, 0 to 1000																										
C+1	0XX0	Re-transmissions	Response monitor time (0.1 to 25.4 s)																								
C+2	0000	0000	Destination node no. (0 to 62)																								
<b>SUBROUTINE ENTER</b> (@)SBS(91)		Calls subroutine N. Moves program operation to the specified subroutine.	<p><b>N:</b> 00 to 99</p>																								

**Data Areas**

These footnote tables show the actual ranges of all data areas. Bit numbers are provided (except for DM and TC areas); remove the rightmost two digits for word numbers.

IR	SR	HR	TR	AR	LR	TC	DM	#
00000 to 23515	23600 to 25507	HR 0000 to 9915	TR 0 to 7	AR 0000 to 2715	LR 0000 to 6315	TC 000 to 511	Read/Wr: DM 0000 to DM 0999 Rd only: DM 1000 to DM 1999	0000 to 9999 or 0000 to FFFF

Name Mnemonic	Symbol	Function	Operand Data Areas			
<b>SUBROUTINE START</b> SBN(92)	— <table border="1" style="display: inline-table; vertical-align: middle;"><tr><td>SBN(92) N</td></tr></table>	SBN(92) N	Marks the start of subroutine N.	<b>N:</b> 00 to 99		
SBN(92) N						
<b>RETURN</b> RET(93)	— <table border="1" style="display: inline-table; vertical-align: middle;"><tr><td>RET(93)</td></tr></table>	RET(93)	Marks the end of a subroutine and returns control to the main program.	None		
RET(93)						
<b>WATCHDOG TIMER REFRESH</b> (@)WDT(94)	— <table border="1" style="display: inline-table; vertical-align: middle;"><tr><td>WDT(94) T</td></tr></table>	WDT(94) T	Sets the maximum and minimum limits for the watchdog timer (normally 0 to 130 ms). New limits: Maximum time = 130 + (100 x T) Minimum time = 130 + (100 x (T-1))	<b>T:</b> 0 to 63		
WDT(94) T						
<b>I/O REFRESH</b> (@)IORF(97)	— <table border="1" style="display: inline-table; vertical-align: middle;"><tr><td>IORF(97)</td></tr><tr><td>St</td></tr><tr><td>E</td></tr></table>	IORF(97)	St	E	Refreshes all I/O words between the start (St) and end (E) words. Only I/O words may be designated. Normally these words are refreshed only once per cycle, but refreshing words before use in an instruction can increase execution speed. St must be less than or equal to E.	<b>St/E:</b> IR
IORF(97)						
St						
E						

**Data Areas**

These footnote tables show the actual ranges of all data areas. Bit numbers are provided (except for DM and TC areas); remove the rightmost two digits for word numbers.

IR	SR	HR	TR	AR	LR	TC	DM	#
00000 to 23515	23600 to 25507	HR 0000 to 9915	TR 0 to 7	AR 0000 to 2715	LR 0000 to 6315	TC 000 to 511	Read/Wr: DM 0000 to DM 0999 Rd only: DM 1000 to DM 1999	0000 to 9999 or 0000 to FFFF

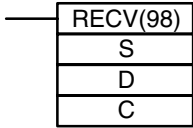
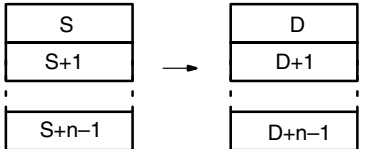
Name Mnemonic	Symbol	Function	Operand Data Areas																								
<p><b>NETWORK RECEIVE</b>                      (@)RECV(98)                      (CPU11)</p>		<p>Transfers data from the source words (S is the first word) from node N of the specified network (in a SYSMAC LINK or NET Link System) to the destination words starting at D. The format of the control words varies depending on the type of system. In both types of systems, the first control word (C) gives the number of words to be transferred.</p> <p>For NET Link Systems, in the second word (C+1), bit 14 specifies the system (0 for system 1, and 1 for system 0), and the rightmost 7 bits define the network number. The left half of word C+2 specifies the source port (00: NSB, 01/02: NSU), and the right half specifies the source node number.</p> <p>For SYSMAC LINK Systems, the right half of C+1 specifies the response monitoring time (default 00: 2 s, FF: monitoring disabled), the next digit to the left gives the maximum number of re-transmissions (0 to 15) that the PC will attempt if no response signal is received. Bit 13 specifies whether a response is needed (0) or not (1), and bit 14 specifies the system number (0 for system 1, and 1 for system 0). The right half of C+2 gives the source node number.</p> <p><b>NET Link</b></p> <table border="1" data-bbox="760 1024 1192 1150"> <tr> <td>C</td> <td colspan="3">n: no. of words to be transmitted (0 to 1000)</td> </tr> <tr> <td>C+1</td> <td>0X00</td> <td>0000</td> <td>Network no. (0 to 127)</td> </tr> <tr> <td>C+2</td> <td colspan="2">Source port no. (NSB: 00, NSU: 01/02)</td> <td>Source node no. (0 to 126)</td> </tr> </table> <p><b>SYSMAC LINK</b></p> <table border="1" data-bbox="760 1213 1192 1352"> <tr> <td>C</td> <td colspan="3">n: no. of words to be transmitted, 0 to 1000</td> </tr> <tr> <td>C+1</td> <td>0XX0</td> <td>Re-transmissions</td> <td>Response monitor time (0.1 to 25.4 s)</td> </tr> <tr> <td>C+2</td> <td>0000</td> <td>0000</td> <td>Source node no. (0 to 62)</td> </tr> </table> <p>Source node N      Destination node</p> 	C	n: no. of words to be transmitted (0 to 1000)			C+1	0X00	0000	Network no. (0 to 127)	C+2	Source port no. (NSB: 00, NSU: 01/02)		Source node no. (0 to 126)	C	n: no. of words to be transmitted, 0 to 1000			C+1	0XX0	Re-transmissions	Response monitor time (0.1 to 25.4 s)	C+2	0000	0000	Source node no. (0 to 62)	<p><b>S:</b>                      IR                      SR                      HR                      AR                      LR                      TC                      DM</p> <p><b>C/D:</b>                      IR                      HR                      AR                      LR                      TC                      DM</p>
C	n: no. of words to be transmitted (0 to 1000)																										
C+1	0X00	0000	Network no. (0 to 127)																								
C+2	Source port no. (NSB: 00, NSU: 01/02)		Source node no. (0 to 126)																								
C	n: no. of words to be transmitted, 0 to 1000																										
C+1	0XX0	Re-transmissions	Response monitor time (0.1 to 25.4 s)																								
C+2	0000	0000	Source node no. (0 to 62)																								

**Data Areas**

These footnote tables show the actual ranges of all data areas. Bit numbers are provided (except for DM and TC areas); remove the rightmost two digits for word numbers.

IR	SR	HR	TR	AR	LR	TC	DM	#
00000 to 23515	23600 to 25507	HR 0000 to 9915	TR 0 to 7	AR 0000 to 2715	LR 0000 to 6315	TC 000 to 511	Read/Wr: DM 0000 to DM 0999 Rd only: DM 1000 to DM 1999	0000 to 9999 or 0000 to FFFF



# Glossary

<b>ASCII code</b>	[A(merican) S(tandard) C(ode for) I(nformation) I(nterchange)] A standard computer code used to facilitate the interchange of information among various types of data-processing equipment.
<b>ASCII Unit</b>	An Intelligent I/O Unit. The ASCII Unit has its own CPU and 16 kilobytes of memory. This Unit enables communication between the PC and any other device which uses ASCII code. The ASCII Unit can be programmed in BASIC.
<b>Backplane</b>	A base to which Units are mounted to form a Rack. Backplanes provide a series of connectors for these Units along with wiring to connect them to the CPU and Power Supply. Backplanes also provide connectors used to connect them to other Backplanes. In some Systems, different Backplanes are used for different Racks; in other Systems, Racks differ only by the Units mounted to them.
<b>back-up</b>	A copy of existing data which is valuable if data is accidentally erased.
<b>baud rate</b>	Transfer speed between two devices in a system measured in bits per second. For example, an optical sensor might be configured to send its information to the FIT at 9600 baud. It is important for both of the devices to be set to the same baud rate.
<b>bit</b>	The smallest piece of information that can be represented on a computer. A bit has the value of either zero or one, corresponding to the electrical signals ON and OFF. A bit is one binary digit.
<b>central processing unit</b>	A device that is capable of storing a program and data, and executing the set of instructions contained in the program. In a PC System, the central processing unit executes the program, processes I/O signals, communicates with external devices, etc.
<b>communication cable</b>	Cable used to transfer data between components of a control system and conforming to the RS-232C or RS-422 standards.
<b>Control System</b>	All of the hardware and software components used to control other devices. A Control System includes the PC System, the PC programs, and all I/O devices that are used to control or obtain feedback from the controlled system.
<b>counter</b>	A PC function that counts the number of occurrences of a certain event.
<b>CPU</b>	An acronym for central processing unit.
<b>cycle time</b>	The total time it takes the PC to perform internal operations, i.e., reset the watchdog timer, read the program, receive input data, send output data, and execute instructions. Cycle time is monitored by the watchdog timer within the PC, and if it takes longer than a certain specified amount of time, an error message may be generated, or the CPU may just stop. Cycle times will differ depending on the configuration of the system.
<b>data area</b>	An area in the PC's memory that is designed to hold a specific type of data, e.g., the LR area is designed to hold common data in a PC Link System.

---

## *Glossary*

---

<b>data disk</b>	Floppy disk used to store information such as programs or I/O tables. The data disk should be used in drive B of the FIT.
<b>data link</b>	Allows for the connection of up to 32 PCs in a Net Link System where each is contributing information to a common memory area. Data links may be established in the LR and/or DM memory areas.
<b>debugging</b>	The process of checking for errors in a program.
<b>default condition</b>	The original condition of a function or system. For example, the FIT's default condition is to start from its hard drive, but this default condition can be changed so that it starts from a floppy disk drive.
<b>distributed control</b>	An automation concept in which control of each portion of an automated system is located near the devices actually being controlled, i.e., control is decentralized and "distributed" over the system. Distributed control is a concept basic to PC Systems.
<b>EEPROM</b>	[E(lectrically) E(rasable) P(rogrammable) R(ead) O(nly) M(emory)] A type of ROM in which stored data can be erased and reprogrammed. This is accomplished using a special control lead connected to the EEPROM chip and can be done without having to remove the EEPROM chip from the device in which it is mounted.
<b>electrical noise</b>	Electric 'static' that can disturb electronic communications. The 'snow' that can appear on a TV screen is an example of the effects of electrical noise.
<b>EPROM</b>	[E(rasable) P(rogrammable) R(ead) O(nly) M(emory)] A type of ROM in which stored data can be erased, by ultraviolet light or other means, and reprogrammed.
<b>Expansion I/O Unit</b>	An I/O Unit for a Package-type PC that provides more I/O points to the PC.
<b>factory computer</b>	A general-purpose computer, usually quite similar to a business computer, that is used in automated factory control.
<b>flag</b>	A bit that is turned ON and OFF automatically by the system in order to provide status information.
<b>High-speed Counter</b>	A Special I/O Unit. A High Speed Counter Unit counts independently of the PC's cycle time. This allows counting of very short, fast signals.
<b>host computer</b>	A computer that is used to transfer data to or receive data from a PC in a Host Link system. The host computer is used for data management and overall system control. Host computers are generally small personal or business computers.
<b>IBM PC/XT or AT, or compatibles</b>	A computer that has similar architecture to, and is logically compatible with an IBM PC/XT computer; and that can run software designed for that computer.
<b>instruction line</b>	A succession of instructions which begins with a load instruction at the left bus bar and ends at a right bus bar.

<b>interface</b>	An interface is the conceptual boundary between systems or devices and usually involves changes in the way the communicated data is represented. Interface devices such as NSBs perform operations such as changing the coding, format, or speed of data.
<b>I/O devices</b>	The devices which are connected to the terminals on I/O Units, Special I/O Units, or Intelligent I/O Units. I/O devices may be part of the Control System if they function to help control other devices, or they may be part of the controlled system if they interact directly with it.
<b>I/O point</b>	The place at which an input signal enters the PC System or an output signal leaves the PC System. In physical terms, an I/O point corresponds to terminals or connector pins on a Unit; in terms of programming, an I/O point corresponds to an I/O bit in the IR area.
<b>I/O table</b>	Diagram written to the IR memory area listing the type of I/O units controlled by a PC. It must be cleared before programming or when I/O units are changed. Tables can be read, verified, or transferred to a EPROM.
<b>I/O Unit</b>	The most basic type of Unit mounted to a Backplane. I/O Units include Input Units and Output Units, each of which is available in a range of specifications. I/O Units do not include Special I/O Units, Link Units, etc.
<b>Limit Switch</b>	A switch that detects when an object has reached the limit of its movement by actually making contact with the object. Limit Switches are fitted to electric elevators, traveling cranes, etc. to indicate when a certain part of the equipment has traveled to the specified limit.
<b>Link Unit</b>	Any of the Units used to connect a PC to a Link System. These are Remote I/O Units, I/O Link Units, PC Link Units, Host Link Units, and Net Link Units.
<b>operating mode</b>	The Display Terminal Unit can operate in five different modes: Page Read, Terminal, Dynamic Scan, Read/Write, and Self-Diagnosis.
<b>page</b>	One complete Display Terminal Unit screen. Two hundred screens can be stored on one RAM card.
<b>parallel interface</b>	The parallel interface uses the RS-232 connector, but is not serial communication. When parallel mode is selected as the communication mode, up to 16 Display Terminal Units can be connected to a PC in parallel.
<b>PC</b>	An acronym for Programmable Controller.
<b>PCB</b>	An acronym for printed circuit board.
<b>PC Link Unit</b>	A Unit used to connect two or more PCs together so that they can exchange data through their LR areas.
<b>Photoelectric Switch</b>	A switch that uses light to detect the presence of an object.
<b>Power Supply</b>	A Unit that mounts to a Backplane in a Rack PC. It provides power at the voltage required by the other Units on the Rack.
<b>printed circuit board</b>	A board onto which electrical circuits are printed for mounting into a computer or electrical device.

<b>Programmable Controller</b>	A small, computer-like device that can control peripheral equipment, such as an electric door or quality control devices, based on programming and peripheral input devices. Any process that can be controlled using electrical signals can be controlled by a PC. PCs can be used independently or networked together into a system to control more complex operations.
<b>programming device</b>	A peripheral device used to write programs and to input a program to a PC or to alter or monitor a program already stored in the PC. There are dedicated programming devices, such as Programming Consoles, and there are non-dedicated programming devices, such as a host computer.
<b>PROM</b>	[P(rogrammable) R(ead) O(nly) M(emory)] A type of ROM into which the program or data may be written after manufacture, by a customer, but which is fixed from that time on.
<b>PROM Writer</b>	A PROM Writer is a device used to write data to ROM, PROM, and EPROM storage chips.
<b>Proximity Switch</b>	A switch that uses magnetic induction to measure the distance of a metallic object from the front of the switch.
<b>Rack PC</b>	A PC that is composed of Units mounted to one or more Racks. This configuration is the most flexible, and most large PCs are Rack PCs. A Rack PC is the opposite of a Package-type PC, which has all of the basic I/O, storage, and control functions built into a single package.
<b>RAM</b>	[R(andom) A(ccess) M(emory)] RAM will not retain data when power is disconnected. Therefore data should not be stored in RAM.
<b>register/registered</b>	Storing text and graphics in the RAM/ROM card from a personal computer or the ASCII Unit. Graphics that have been written to the RAM/ROM card are referred to as registered messages.
<b>Remote I/O Unit</b>	A Unit that extends the distance an Expansion I/O Unit can be from the CPU.
<b>ROM</b>	[R(ead) O(nly) M(emory)] A type of digital storage that cannot be written to. A ROM chip is manufactured with its program or data already stored in it, and it can never be changed. However, the program or data can be read as many times as desired.
<b>switching capacity</b>	The voltage/current that relay can switch ON and OFF.
<b>stepping motor</b>	An output device that rotates according to signals from the Control System. The rotation is very precise and occurs in pre-defined "steps".
<b>switch</b>	An input device that sends either an ON or OFF signal to the Control System. A switch can be operated either by a person or by the movement of a piece of equipment or material.
<b>system configuration</b>	The arrangement in which Units in a System are connected. This term refers to the conceptual arrangement and wiring together of all the devices needed to comprise the System. In OMRON terminology, system configuration is used to describe the arrangement and connection of the Units comprising a Control System that includes one or more PCs.

<b>Unit</b>	In OMRON PC terminology, the word Unit is capitalized to indicate any product sold for a PC System. though most of the names of these products end with the word Unit, not all do, e.g., a Remote Terminal is referred to in a collective sense as a Unit. Context generally makes any limitations of this word clear.
<b>watchdog timer</b>	A special timer inside the CPU that monitors the PC's cycle time. The watchdog timer sets a flag if the cycle time becomes longer than a certain specified value. This is useful if the correct operation of your System depends on a certain maximum cycle time.
<b>word</b>	In digital circuits, a group of bits. Usually a word consists of four, eight, or sixteen bits. In C-series PCs, a word consists of sixteen bits. Words can be used to store data, or they can be used for I/O.
<b>work bits</b>	Bits in the IR area that are not being used for input or output. These bits can be used in the program in any way desired.



# Index

## A–B

Assembly  
  backplane, ,  
  connecting cable,  
  CPU,  
  Expansion I/O Unit,  
  I/O Units,  
  mounting the Units,  
Backplane,  
  IR word allocation, ,  
Backplane Insulating Plates,  
Battery, Memory Packs, replacement,

## C

C200H-CPU1 1  
  battery, replacement,  
  power consumption, calculation examples,  
Cables,  
control components,  
Control System,  
Cooling  
  clearance between Racks,  
  cooling fan,  
CPU,  
  C200H-CPU01/03,  
  C200H-CPU1 1,  
  indicators,  
  Peripheral Device Connectors,  
    cable connection,  
    direct mounting,  
    wiring,  
CPU Rack,  
Current consumption  
  24-V supply,  
  26-V supply,  
  5-V supply,  
  calculation examples,  
cycle,  
cycle time,

## D–E

Duct work  
  I/O wiring,  
  power cables,  
electrostatic charge,  
Emergency stop circuit,  
Expansion I/O Rack,

## F–H

factory computer,  
Fuse  
  CPU and power supply, replacement,  
  Output, replacement,  
  Output Units,  
Grounding  
  ground terminal,  
  line ground terminal,  
  wire,  
humidity,

## I–L

I/O Devices, connections,  
I/O points, calculating the number of,  
I/O Unit Cover,  
I/O Units,  
  A-shape,  
  B-shape,  
  connections,  
  E-shape,  
input devices,  
installation, environment,  
  ambient conditions,  
Insulating plates,  
IR word allocation, work bits,  
Limit Switch,

## M

Memory Packs  
  assembly,  
  battery failure flag,  
  EEPROM chip,  
  EEPROM Pack,  
  EPROM chip  
    how to mount,  
    mounted to the printed circuit board,  
  EPROM Pack,  
  how to mount to CPU,  
  RAM Pack,  
  switches,  
Mounting requirements,  
  DIN Rail mounting,  
    16-mm DIN Rail,  
    7.3-mm DIN Rail,  
  DIN Rail mounting bracket,  
  procedure,

## N—O

Noise  
  cables,  
  I/O wiring,  
output devices,  
Output Units, external fuse,

## P

PC  
  block diagram,  
  flow chart,  
  operation,  
  role of,  
Photoelectric Switch,  
Power source,  
  wiring,  
Power supply,  
  AC power supply,  
  DC power supply,  
  wiring,  
precautions, general,  
process control computer,  
Programming Console, Hand-held,  
Proximity Switch,

## R

Relay, printed circuit board,  
Relays, Output Unit, replacement,  
Remote I/O,  
  PC Link Units,  
  Special I/O Units,  
  word allocation,

## S

Sequential circuit (for power failure),  
Servomotor,  
  servomotor drivers,  
  servomotors,  
Solenoid,  
Special I/O Units,  
  Remote I/O Slave Rack,  
static electricity, preventing,  
stepping motor,  
system configuration,  
System Configurations,  
  Expansion I/O Racks,  
  Host Link Unit,  
  I/O Connecting cable,  
  Memory Packs,  
  Optical Fiber Cable,  
  Remote I/O Master Unit,  
  Remote I/O Slave Unit,  
  Special I/O Units,  
  Standard I/O Units,  
  SYSMAC Link Unit,

## T

Terminal block,  
terminal block, wiring,

## W

Wiring  
  AC Input Units,  
  DC Input Units,  
  examples,  
  I/O devices,  
  I/O Units,  
  terminal blocks,  
word allocation, for expanded PC,  
work bits,



## Revision History

A manual revision code appears as a suffix to the catalog number on the front cover of the manual.

Cat. No. W111-E1-10  

The following table outlines the changes made to the manual during each revision. Page numbers refer to the previous version.

Revision code	Date	Revised content
6	July 1989	Corrections to pages: 3, 6, 16 to 18, 21, 23, 26, 27, 31, 32, 33, 41, 51, 52, 53, 57, 58, and 60.
7	February 1990	Entire manual reorganized and reproduced.
8	October 1990	Revision of text and inclusion of new product information (C200H-CPU11-E, SYSMAC NET, SYSMAC LINK, C200H-OC225, and C200H-OD212) Corrections to pages: 7, 10, 12, 13, 15, 16, 23, 27, 28, 34 to 39, 61, 63, 64, 82, 85, 94, 97 to 100, 103, 104.
8A	May 1991	<b>Pages 33 to 38:</b> Completely redone. <b>Page 102:</b> Backplane model numbers revised. <b>Page 103:</b> BC031-V1 and BC101-V1 added to note at bottom of page. <b>Page 104:</b> Microwave ID Sensor and Analog I/O Units added. <b>Page 110:</b> Terminal Resistor and Power Supply Adapter model numbers revised. The manual has also been reformatted, changing page numbers slightly.
8B	May 1992	<b>Page 7:</b> PC Operation Flowchart redone. <b>Page 27:</b> The section reference in the second line corrected to <i>Section 2-6 Memory Packs</i> . <b>Page 28:</b> "Optical Fiber Cable" in the lower left corner corrected to "Optical Fiber Cable or Wire Cable". <b>Pages 113 to 128:</b> The following instructions are missing from <i>Appendix E Programming Instructions</i> : LMSG(47), TERM(48), SYS(49), CMPL(60), CTW(63), WTC(64), HTS(65), STH(66), VAL(69), SEND(90), and RECV(98). (These instructions were originally added in revision 8, but inadvertently omitted from revision 8A.)
8C	December 1993	Multipoint I/O changed to High-density I/O throughout the manual. Scan time changed to cycle time throughout the manual. <b>Page 10:</b> Model number corrections made in the first paragraph of <i>CPU</i> . <b>Page 28:</b> Reference corrected for SYSMAC NET Link Unit and SYSMAC LINK Unit. <b>Page 32:</b> Table updated. <b>Page 33:</b> Note added, 1.4 V corrected to 1.4 A in the top table. <b>Pages 34, 35:</b> Models added and updated. <b>Page 37:</b> Calculation of power consumption corrected. <b>Page 38:</b> I/O Unit Cover description added. <b>Page 42:</b> Ambient conditions added. <b>Page 79:</b> "8 A/Unit" in Terminal Connections changed to "16 A/Unit". <b>Page 82:</b> Max. switching capacity changed. <b>Page 92:</b> B7A Interface Unit specifications added. <b>Pages 97 to 105:</b> Appendix C completely updated.

## Revision History

Revision code	Date	Revised content
9	February 1999	<p>References to C200H-OA221 removed throughout the manual.</p> <p><b>Pages 10, 23, 27, 31, 34, 92:</b> C200H-OD21A added.</p> <p><b>Pages 10, 23, 27, 31, 82, 84:</b> Backplane model information corrected.</p> <p><b>Pages 13, 19, 23, 63, 98, 99:</b> Added information on E-shape I/O Units.</p> <p><b>Page 18:</b> Number of terminals for B-shape I/O Units corrected.</p> <p><b>Pages 34:</b> Model numbers of SYSMAC LINK and SYSMAC NET Link Units changed. C200H-OA224 added.</p> <p><b>Pages 34, 66:</b> C200H-IA222V added.</p> <p><b>Pages 34, 76:</b> C200H-OA222V added. C200H-OA222 removed.</p> <p><b>Pages 34, 78:</b> C200H-OA122-E added. C200H-OA224/OA223 added.</p> <p><b>Pages 35:</b> Analog I/O Units added/corrected.</p> <p><b>Pages 39 to 40:</b> Precautions for connecting DC two-wire sensors added.</p> <p><b>Page 41:</b> Caution added.</p> <p><b>Page 57:</b> Fuse specifications table added.</p> <p><b>Pages 60, 61:</b> Added step to procedures.</p> <p><b>Page 63:</b> Power consumption and dielectric strength corrected, and surge current added.</p> <p><b>Pages 73 to 76:</b> Specifications for C200H-ID218 and C200H-ID219 DC Input Units added.</p> <p><b>Page 77:</b> Circuit configuration corrected for C200H-OA121-E.</p> <p><b>Pages 84, 85:</b> Circuit configurations changed for C200H-OD212 and C200H-OD213.</p> <p><b>Pages 95, 96:</b> B7A Interface Unit information modified.</p> <p><b>Page 99:</b> Insulation plate mounting dimensions corrected.</p> <p><b>Pages 100 to 111:</b> Standard models list updated.</p>
10	January 2001	<p><b>Page xii:</b> Minor change made to last caution.</p> <p><b>Page xiii:</b> Changes made to wording of information on grounding and mounting.</p> <p><b>Pages 16, 17:</b> Minor changes made to graphics.</p> <p><b>Page 17:</b> Information on LG and GR terminals added.</p> <p><b>Page 19:</b> "Pack" changed to "Unit" in several places. Information on Memory Units added.</p> <p><b>Page 37:</b> Minor change to last sentence.</p> <p><b>Pages 51, 52:</b> Information on power supply wiring added.</p> <p><b>Page 63:</b> S.I. data replaced with metric equivalent.</p>





## OMRON ELECTRONICS LLC

1 Commerce Drive  
Schaumburg, IL 60173  
847.843.7900  
For US technical support or  
other inquiries: 800.556.6766

## OMRON CANADA, INC.

885 Milner Avenue  
Toronto, Ontario M1B 5V8  
416.286.6465

## OMRON ON-LINE

Global - <http://www.omron.com>  
USA - <http://www.omron.com/oei>  
Canada - <http://www.omron.ca>

### UNITED STATES

To locate a Regional Sales Office, local Distributor or  
to obtain product information, call: 847.843.7900

### CANADA REGIONAL SALES OFFICES

<b>Ontario</b>	Toronto	416.286.6465
	Kitchener	519.896.1144
	Kingston	613.376.3968
<b>Quebec</b>	Montreal	514.636.6676
<b>British Columbia</b>	Vancouver	604.522.8855
<b>Alberta</b>	Edmonton	403.440.0818
	Calgary	403.257.3095

### BRAZIL SALES OFFICE

**Sao Paulo** 55.11.5564.6488

### ARGENTINA SALES OFFICE

**Cono Sur** 54.114.787.1129

### MEXICO SALES OFFICES

**Florida** 954.227.2121      **Ciudad Juarez** 656.623.7083  
**Mexico, D.F.** 555.534.1195      **Monterrey, N.L.** 818.377.4281

Компания «Life Electronics» занимается поставками электронных компонентов импортного и отечественного производства от производителей и со складов крупных дистрибьюторов Европы, Америки и Азии.

С конца 2013 года компания активно расширяет линейку поставок компонентов по направлению коаксиальный кабель, кварцевые генераторы и конденсаторы (керамические, пленочные, электролитические), за счёт заключения дистрибьюторских договоров

Мы предлагаем:

- Конкурентоспособные цены и скидки постоянным клиентам.
- Специальные условия для постоянных клиентов.
- Подбор аналогов.
- Поставку компонентов в любых объемах, удовлетворяющих вашим потребностям.
- Приемлемые сроки поставки, возможна ускоренная поставка.
- Доставку товара в любую точку России и стран СНГ.
- Комплексную поставку.
- Работу по проектам и поставку образцов.
- Формирование склада под заказчика.
- Сертификаты соответствия на поставляемую продукцию (по желанию клиента).
- Тестирование поставляемой продукции.
- Поставку компонентов, требующих военную и космическую приемку.
- Входной контроль качества.
- Наличие сертификата ISO.

В составе нашей компании организован Конструкторский отдел, призванный помогать разработчикам, и инженерам.

Конструкторский отдел помогает осуществить:

- Регистрацию проекта у производителя компонентов.
- Техническую поддержку проекта.
- Защиту от снятия компонента с производства.
- Оценку стоимости проекта по компонентам.
- Изготовление тестовой платы монтаж и пусконаладочные работы.



Тел: +7 (812) 336 43 04 (многоканальный)

Email: [org@lifeelectronics.ru](mailto:org@lifeelectronics.ru)