

Optocoupler, Phototransistor Output, ATEX Certified

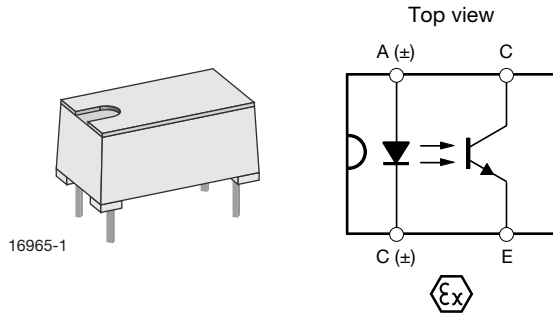

DESCRIPTION

The CNY65Exi consists of a phototransistor optically coupled to an infrared-emitting diode in a 4 pin plastic package. The components are mounted opposite one another, with a distance between input and output of > 3.0 mm; meeting the highest of safety requirements.

The CNY65Exi is ATEX certified for explosive atmospheres according to the European Guide line 94/9/EG.

AGENCY APPROVALS

- ATEX Ex : PTB 03 ATEX 2033 U
 EN 60079-0:2012
 EN 60079-11:2012
 EN 60079-26:2007

FEATURES

- ATEX certificate: PTB 03 ATEX 2033 U
www.vishay.com/doc?85361
- Suitable for intrinsic safe circuits for gas and dust
- Gas safety provision: II (1) G (EX ia) IIC
- Dust safety provision: II (1) D (EX ia) IIIC
- Conforms to EN60079-0:2012
- Qualified for continuously, longterm, or frequently dangerous explosive environments, zone 0
- Isolation voltage (V_{ISO}) of 11 600 V_{peak} for 1 minute
- Distance from emitter to detector through insulation ≥ 3 mm
- CTR from 50 % to 300 %
- Very low coupling capacity (C_K)
 - 0.3 pF superior noise immunity between input and output pins
- Material categorization: for definitions of compliance please see www.vishay.com/doc?99912

RoHS
 COMPLIANT

APPLICATIONS

- Electronics used in potentially explosive gas and dust environments
 - Safety related process automation and instrumentation
 - Natural gas metering and flow measurement
 - Power and motor switching
 - Power supplies, metering, and data acquisition
 - Lighting and signaling
 - Petrol and grain transport and storage

ORDERING INFORMATION																	
<table border="1" style="margin: auto;"> <tr> <td style="padding: 5px;">C</td> <td style="padding: 5px;">N</td> <td style="padding: 5px;">Y</td> <td style="padding: 5px;">6</td> <td style="padding: 5px;">5</td> <td style="padding: 5px;">X</td> <td style="padding: 5px;">E</td> <td style="padding: 5px;">x</td> <td style="padding: 5px;">i</td> </tr> </table>	C	N	Y	6	5	X	E	x	i	PART NUMBER	<table border="1" style="margin: auto;"> <tr> <td style="padding: 5px;">X</td> </tr> </table> CTR BIN	X	<table border="1" style="margin: auto;"> <tr> <td style="padding: 5px;">E</td> <td style="padding: 5px;">x</td> <td style="padding: 5px;">i</td> </tr> </table> PACKAGE OPTION	E	x	i	
C	N	Y	6	5	X	E	x	i									
X																	
E	x	i															
AGENCY CERTIFIED/PACKAGE	CTR (%)																
ATEX	50 to 300	100 to 200															
DIP-4, HV, high isolation distance	CNY65Exi	CNY65BExi															



ABSOLUTE MAXIMUM RATINGS (T _{amb} = 25 °C, unless otherwise specified)				
PARAMETER	TEST CONDITION	SYMBOL	VALUE	UNIT
INPUT				
Reverse voltage		V _R	5	V
Forward current		I _F	75	mA
Forward surge current	t _p ≤ 10 μs	I _{FSM}	1.5	A
Power dissipation		P _{diss}	120	mW
Junction temperature		T _j	100	°C
OUTPUT				
Collector emitter voltage		V _{CEO}	32	V
Emitter collector voltage		V _{ECO}	7	V
Collector current		I _C	50	mA
Collector peak current	t _p /T = 0.5, t _p ≤ 10 ms	I _{CM}	100	mA
Power dissipation		P _{diss}	130	mW
Junction temperature		T _j	100	°C
COUPLER				
DC isolation test voltage	t = 1 min	V _{ISO}	11.6	kV
Total power dissipation		P _{tot}	250	mW
Ambient temperature range		T _{amb}	-55 to +85	°C
Storage temperature range		T _{stg}	-55 to +100	°C
Soldering temperature	2 mm from case, t ≤ 10 s	T _{slid}	260	°C

Note

- Stresses in excess of the absolute Maximum Ratings can cause permanent damage to the device. Functional operation of the device is not implied at these or any other conditions in excess of those given in the operational sections of this document. Exposure to absolute Maximum Rating for extended periods of the time can adversely affect reliability.

ELECTRICAL CHARACTERISTICS (T _{amb} = 25 °C, unless otherwise specified)						
PARAMETER	TEST CONDITION	SYMBOL	MIN.	TYP.	MAX.	UNIT
INPUT						
Forward voltage	I _F = 50 mA	V _F		1.25	1.6	V
OUTPUT						
Collector emitter voltage	I _C = 1 mA	V _{CEO}	32			V
Emitter collector voltage	I _E = 100 μA	V _{ECO}	7			V
Collector dark current	V _{CE} = 20 V, I _F = 0, E = 0	I _{CEO}			200	nA
COUPLER						
DC isolation test voltage	t = 1 min	V _{ISO} ⁽¹⁾	11.6			kV
Isolation resistance	V _{IO} = 1 kV, 40 % relative humidity	R _{IO} ⁽¹⁾		10 ¹²		Ω
Collector saturation voltage	I _F = 10 mA, I _C = 1 mA	V _{CEsat}			0.3	V
Cut-off frequency	V _{CE} = 5 V, I _F = 10 mA, R _L = 100 Ω	f _c	110			kHz
Coupling capacitance	f = 1 MHz	C _k		0.3		pF

Notes

- Minimum and maximum values are testing requirements. Typical values are characteristics of the device and are the result of engineering evaluation. Typical values are for information only and are not part of the testing requirements.
- ⁽¹⁾ Related to standard climate 23/50 DIN 50014.

CURRENT TRANSFER RATIO (T _{amb} = 25 °C, unless otherwise specified)							
PARAMETER	TEST CONDITION	PART	SYMBOL	MIN.	TYP.	MAX.	UNIT
I _C /I _F	V _{CE} = 5 V, I _F = 10 mA	CNY65Exi	CTR	50	100	300	%
		CNY65BExi	CTR	100		200	%

SWITCHING CHARACTERISTICS ($T_{amb} = 25\text{ }^{\circ}\text{C}$, unless otherwise specified)						
PARAMETER	TEST CONDITION	SYMBOL	MIN.	TYP.	MAX.	UNIT
Delay time	$V_S = 5\text{ V}$, $I_C = 5\text{ mA}$, $R_L = 100\ \Omega$, (see figure 1)	t_d		2.6		μs
Rise time	$V_S = 5\text{ V}$, $I_C = 5\text{ mA}$, $R_L = 100\ \Omega$, (see figure 1)	t_r		2.4		μs
Fall time	$V_S = 5\text{ V}$, $I_C = 5\text{ mA}$, $R_L = 100\ \Omega$, (see figure 1)	t_f		2.4		μs
Storage time	$V_S = 5\text{ V}$, $I_C = 5\text{ mA}$, $R_L = 100\ \Omega$, (see figure 1)	t_s		0.3		μs
Turn-on time	$V_S = 5\text{ V}$, $I_C = 5\text{ mA}$, $R_L = 100\ \Omega$, (see figure 1)	t_{on}		5		μs
Turn-off time	$V_S = 5\text{ V}$, $I_C = 5\text{ mA}$, $R_L = 100\ \Omega$, (see figure 1)	t_{off}		3		μs
Turn-on time	$V_S = 5\text{ V}$, $I_F = 10\text{ mA}$, $R_L = 1\text{ k}\Omega$, (see figure 2)	t_{on}		25		μs
Turn-off time	$V_S = 5\text{ V}$, $I_F = 10\text{ mA}$, $R_L = 1\text{ k}\Omega$, (see figure 2)	t_{off}		42.5		μs

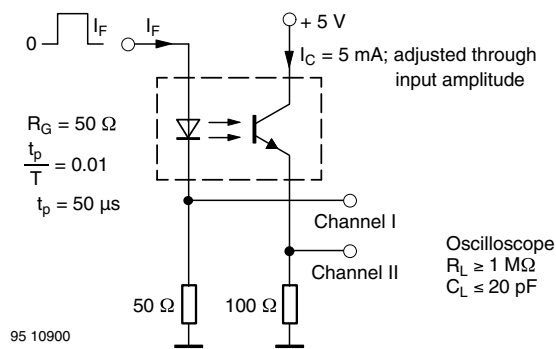

Fig. 1 - Test Circuit, Non-Saturated Operation

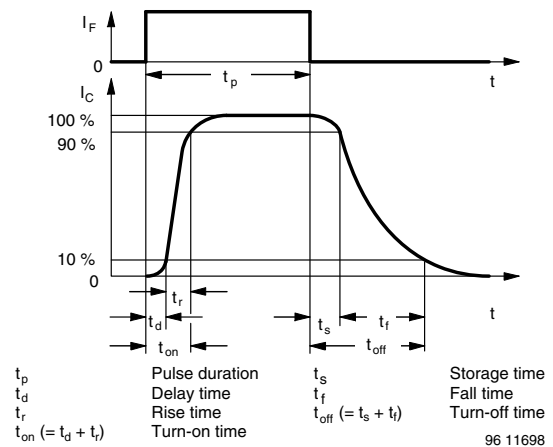

Fig. 3 - Switching Times

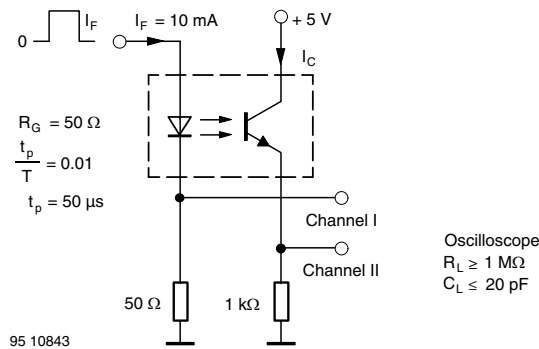

Fig. 2 - Test Circuit, Saturated Operation

TYPICAL CHARACTERISTICS ($T_{amb} = 25\text{ }^{\circ}\text{C}$, unless otherwise specified)

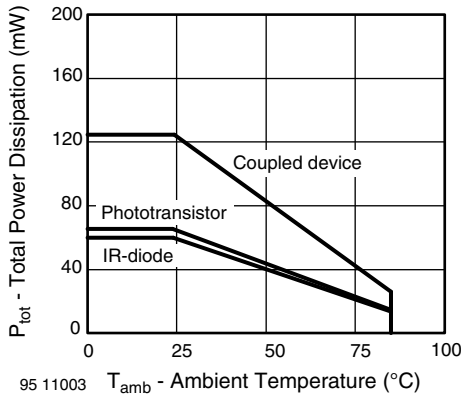

Fig. 4 - Total Power Dissipation vs. Ambient Temperature

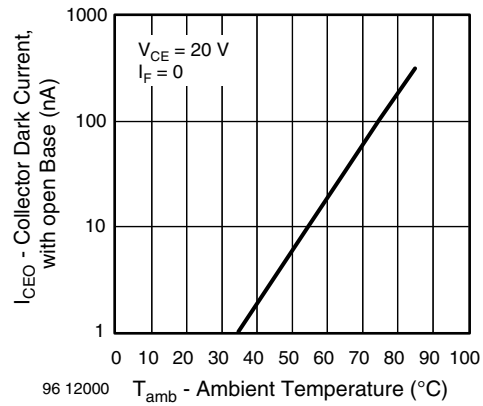
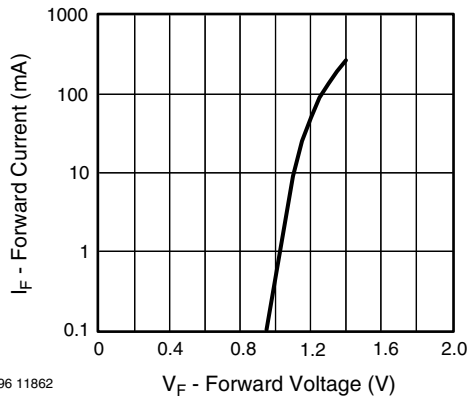
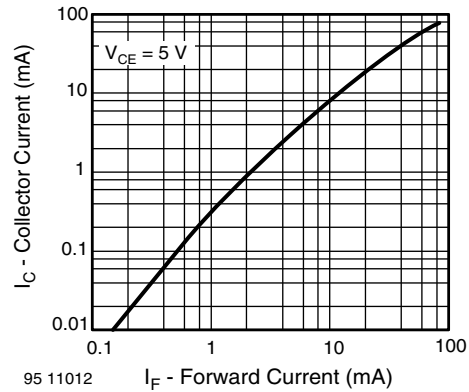

Fig. 7 - Collector Dark Current vs. Ambient Temperature



96 11862

Fig. 5 - Forward Current vs. Forward Voltage



95 11012

Fig. 8 - Collector Current vs. Forward Current

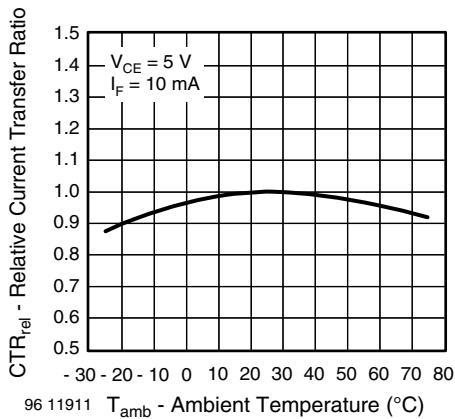

96 11911

Fig. 6 - Relative Current Transfer Ratio vs. Ambient Temperature

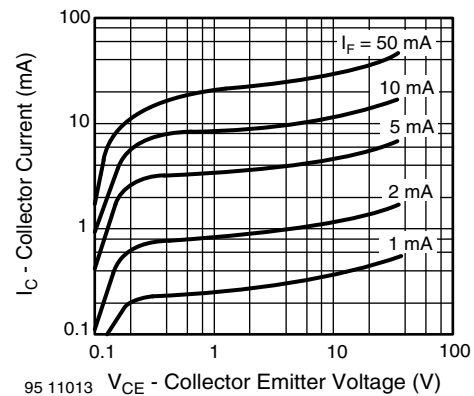

95 11013

Fig. 9 - Collector Current vs. Collector Emitter Voltage

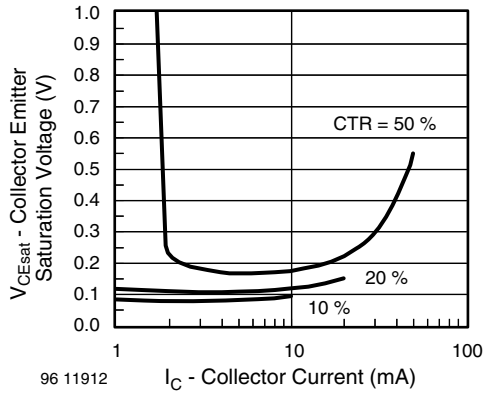

Fig. 10 - Collector Emitter Saturation Voltage vs. Collector Current

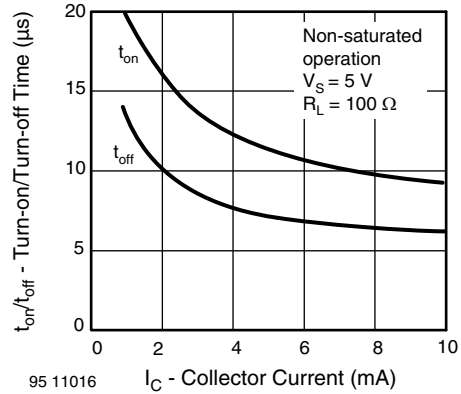

Fig. 13 - Turn-on/Turn-off Time vs. Collector Current

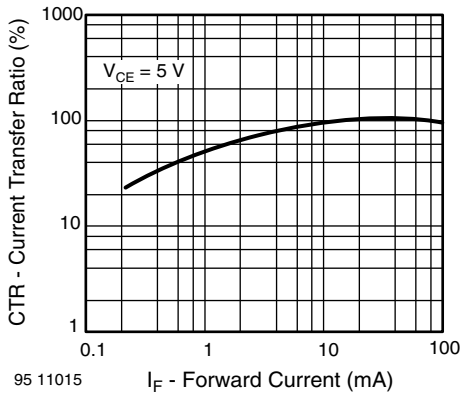

Fig. 11 - Current Transfer Ratio vs. Forward Current

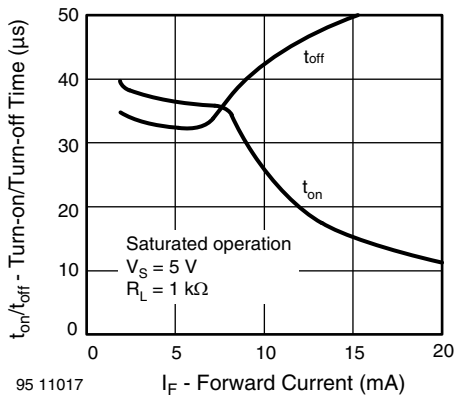
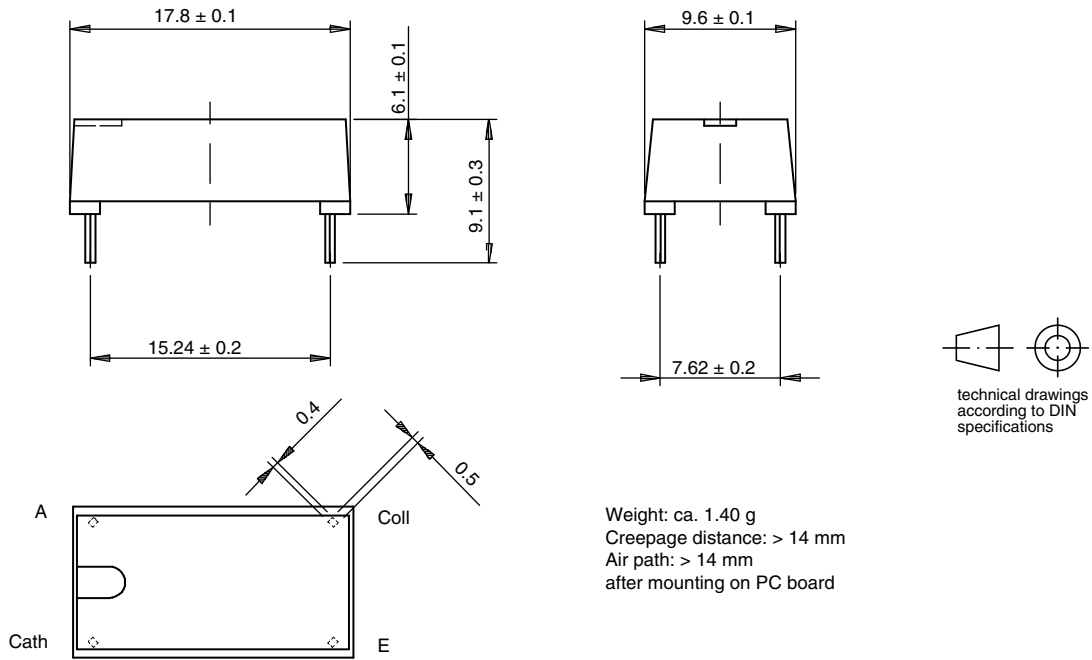

Fig. 12 - Turn-on/Turn-off Time vs. Forward Current



PACKAGE DIMENSIONS in millimeters



Drawing-No.: 6.544-5036.01-1
Issue: 2; 10.11.98
14763

PACKAGE MARKING (example of CNY65BExi)

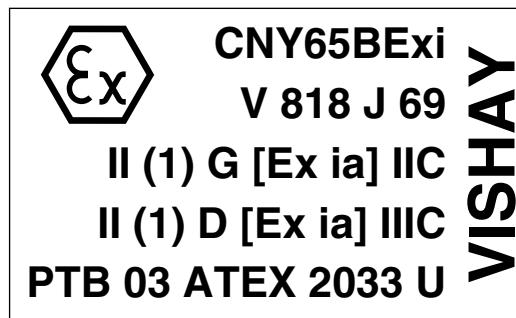

HANDLING AND STORAGE CONDITIONS

ESD level: HBM class 2



Disclaimer

ALL PRODUCT, PRODUCT SPECIFICATIONS AND DATA ARE SUBJECT TO CHANGE WITHOUT NOTICE TO IMPROVE RELIABILITY, FUNCTION OR DESIGN OR OTHERWISE.

Vishay Intertechnology, Inc., its affiliates, agents, and employees, and all persons acting on its or their behalf (collectively, "Vishay"), disclaim any and all liability for any errors, inaccuracies or incompleteness contained in any datasheet or in any other disclosure relating to any product.

Vishay makes no warranty, representation or guarantee regarding the suitability of the products for any particular purpose or the continuing production of any product. To the maximum extent permitted by applicable law, Vishay disclaims (i) any and all liability arising out of the application or use of any product, (ii) any and all liability, including without limitation special, consequential or incidental damages, and (iii) any and all implied warranties, including warranties of fitness for particular purpose, non-infringement and merchantability.

Statements regarding the suitability of products for certain types of applications are based on Vishay's knowledge of typical requirements that are often placed on Vishay products in generic applications. Such statements are not binding statements about the suitability of products for a particular application. It is the customer's responsibility to validate that a particular product with the properties described in the product specification is suitable for use in a particular application. Parameters provided in datasheets and/or specifications may vary in different applications and performance may vary over time. All operating parameters, including typical parameters, must be validated for each customer application by the customer's technical experts. Product specifications do not expand or otherwise modify Vishay's terms and conditions of purchase, including but not limited to the warranty expressed therein.

Except as expressly indicated in writing, Vishay products are not designed for use in medical, life-saving, or life-sustaining applications or for any other application in which the failure of the Vishay product could result in personal injury or death. Customers using or selling Vishay products not expressly indicated for use in such applications do so at their own risk. Please contact authorized Vishay personnel to obtain written terms and conditions regarding products designed for such applications.

No license, express or implied, by estoppel or otherwise, to any intellectual property rights is granted by this document or by any conduct of Vishay. Product names and markings noted herein may be trademarks of their respective owners.

Material Category Policy

Vishay Intertechnology, Inc. hereby certifies that all its products that are identified as RoHS-Compliant fulfill the definitions and restrictions defined under Directive 2011/65/EU of The European Parliament and of the Council of June 8, 2011 on the restriction of the use of certain hazardous substances in electrical and electronic equipment (EEE) - recast, unless otherwise specified as non-compliant.

Please note that some Vishay documentation may still make reference to RoHS Directive 2002/95/EC. We confirm that all the products identified as being compliant to Directive 2002/95/EC conform to Directive 2011/65/EU.

Vishay Intertechnology, Inc. hereby certifies that all its products that are identified as Halogen-Free follow Halogen-Free requirements as per JEDEC JS709A standards. Please note that some Vishay documentation may still make reference to the IEC 61249-2-21 definition. We confirm that all the products identified as being compliant to IEC 61249-2-21 conform to JEDEC JS709A standards.

Компания «Life Electronics» занимается поставками электронных компонентов импортного и отечественного производства от производителей и со складов крупных дистрибьюторов Европы, Америки и Азии.

С конца 2013 года компания активно расширяет линейку поставок компонентов по направлению коаксиальный кабель, кварцевые генераторы и конденсаторы (керамические, пленочные, электролитические), за счёт заключения дистрибьюторских договоров

Мы предлагаем:

- Конкурентоспособные цены и скидки постоянным клиентам.
- Специальные условия для постоянных клиентов.
- Подбор аналогов.
- Поставку компонентов в любых объемах, удовлетворяющих вашим потребностям.
- Приемлемые сроки поставки, возможна ускоренная поставка.
- Доставку товара в любую точку России и стран СНГ.
- Комплексную поставку.
- Работу по проектам и поставку образцов.
- Формирование склада под заказчика.
- Сертификаты соответствия на поставляемую продукцию (по желанию клиента).
- Тестирование поставляемой продукции.
- Поставку компонентов, требующих военную и космическую приемку.
- Входной контроль качества.
- Наличие сертификата ISO.

В составе нашей компании организован Конструкторский отдел, призванный помогать разработчикам, и инженерам.

Конструкторский отдел помогает осуществить:

- Регистрацию проекта у производителя компонентов.
- Техническую поддержку проекта.
- Защиту от снятия компонента с производства.
- Оценку стоимости проекта по компонентам.
- Изготовление тестовой платы монтаж и пусконаладочные работы.



Тел: +7 (812) 336 43 04 (многоканальный)

Email: org@lifeelectronics.ru