

smiths connectors

DOVETAIL CONNECTOR SERIES

CONFIGURABLE INTERCONNECT SOLUTIONS



PROBE OPTIONS

4 mm
COMPRESSED HEIGHT

6 mm
COMPRESSED HEIGHT

6 mm BIAS BALL
COMPRESSED HEIGHT

TERMINATIONS

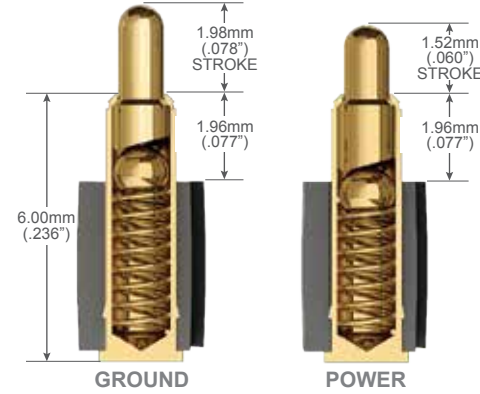
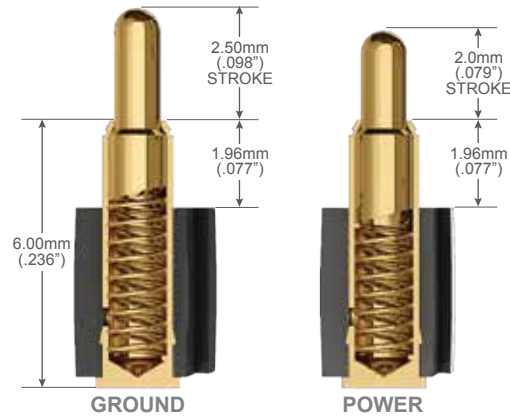
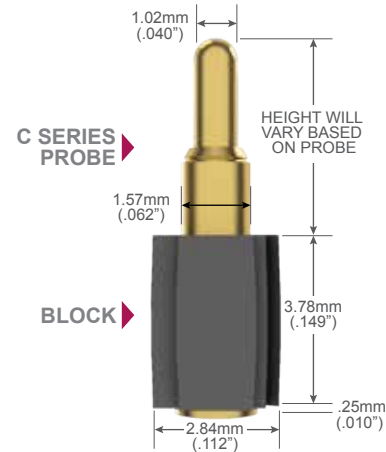

FEATURES & BENEFITS

Smiths Connectors' new Dovetail Connector Series features C Series Probes, renowned for their incomparable shock and vibration performance, housed in a patent pending block design. The symmetrical blocks interlock to allow for simple configuration into any imaginable X-Y pattern. A multitude of probe options permit the benefits of a custom connector design such as intermixing of power and ground functions within the same array. Available for immediate delivery with no tooling required, the Dovetail Connector eliminates the time and expense associated with typical prototype and low to medium volume manufacturing activities.

- ▶ **IMMEDIATE DELIVERY**
Ideal for high mix, low to medium volume manufacturing scales
- ▶ **CUSTOM CONFIGURATIONS**
Available individually or pre-configured to meet application specific requirements

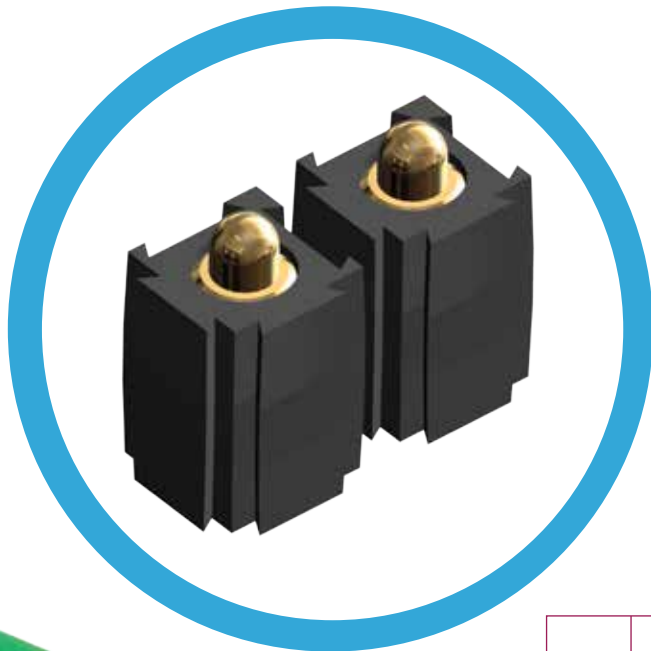

- ▶ **DOVETAIL DESIGN**
Interlocking features permit population to a wide range of footprints
- ▶ **PROBE DIVERSITY**
A variety of termination styles, signal path lengths and performance functions are accommodated within a uniform block design

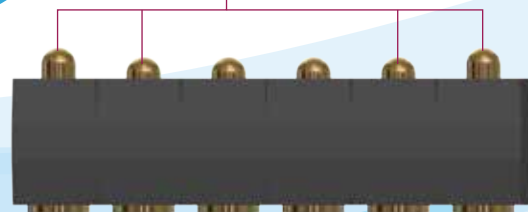

DOVETAIL CONNECTOR SERIES

Patent Pending

PROBE SPECIFICATIONS

4 mm Compressed Height
Pitch: 2.54mm (.100")
Typical Resistance: < 10 mΩ
Current Rating*: 10 amps continuous
Spring Force: 85g (3.0 oz) @ working travel

6 mm Compressed Height
Pitch: 2.54mm (.100")
Typical Resistance: < 10 mΩ
Current Rating*: 10 amps continuous
Spring Force: 82g (2.9 oz) @ working travel

6 mm Bias Ball Compressed Height
Pitch: 2.54mm (.100")
Typical Resistance: < 10 mΩ
Current Rating*: 15 amps continuous
Spring Force: 130g (4.6 oz) @ working travel

*Current ratings typical of single probe in ambient environment

DURABILITY

- ▶ Consistent performance across broad temperature ranges
- ▶ Perfect for RF, high speed and mixed signal connections
- ▶ Minimal insertion and return loss for signals up to 10 GHz
- ▶ Superior continuity in high shock and vibration environments
- ▶ Consistent, low resistance through tens of thousands of connections

PERFORMANCE

SHOCK & VIBRATION TESTING

Smiths Connectors' advanced C Series Probes offer exceptional compliance and design flexibility in a wide range of applications. To enhance the capability of the series in military applications, a version was developed which uses a bias ball design to guarantee electrical performance especially in terms of vibration and shock.

Thorough shock and vibration testing revealed that the C Series Probes passed vibrations tests >15G and shock tests >50G regardless of the internal biasing technology. During the resonance frequencies testing, the 15G input resulted in levels up to 120G (Radial direction) and 60G (Axial direction) at the interface between PCB and spring probe plunger.

After more than 10 hours of vibration and shock testing, the contact surfaces of the spring probe tip and PCB are still free of any wearing or fretting corrosion with near perfect surface finish.

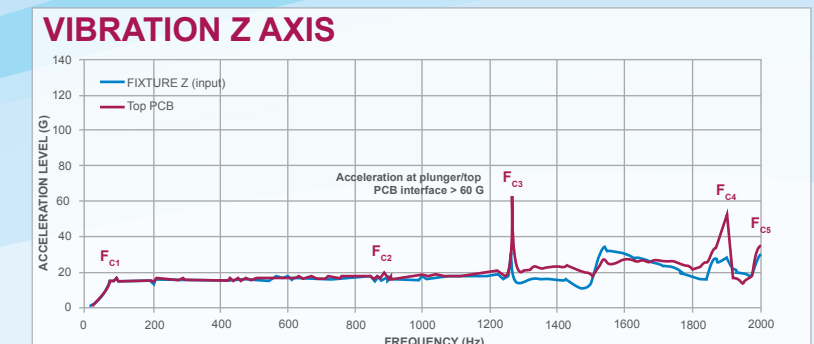
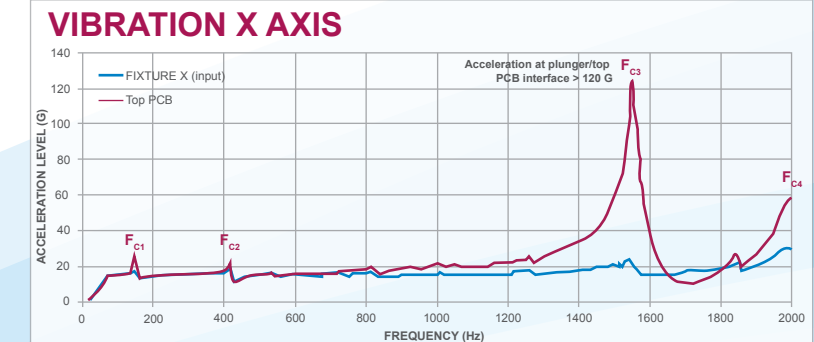

* See back for ordering information

HOW TO ORDER



1 ▶ **DOVETAIL CONNECTOR SERIES** [Fixed]

2 ▶ **C SERIES PROBE** [Fixed]

3 ▶ **CURRENT**

- G** GROUND
- P** POWER



4 ▶ **2.5mm (.100") PITCH** [Fixed]

5 ▶ **COMPRESSED HEIGHT**

- 4** 4mm
- 6** 6mm

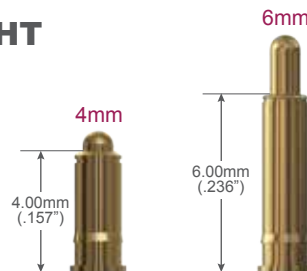

6 ▶ **TERMINATION**

- SM** SURFACE MOUNT
- TH** THRU HOLE
- SC** SOLDER CUP*

SURFACE MOUNT THRU HOLE SOLDER CUP



7 ▶ **BIASING TECHNIQUE***

- BB** BIAS BALL [6mm option only]

BIAS BALL



*omit for standard versions

smiths connectors

FOR MORE INFORMATION | smithsconnectors.com |    

Компания «Life Electronics» занимается поставками электронных компонентов импортного и отечественного производства от производителей и со складов крупных дистрибьюторов Европы, Америки и Азии.

С конца 2013 года компания активно расширяет линейку поставок компонентов по направлению коаксиальный кабель, кварцевые генераторы и конденсаторы (керамические, пленочные, электролитические), за счёт заключения дистрибьюторских договоров

Мы предлагаем:

- Конкуренеспособные цены и скидки постоянным клиентам.
- Специальные условия для постоянных клиентов.
- Подбор аналогов.
- Поставку компонентов в любых объемах, удовлетворяющих вашим потребностям.
- Приемлемые сроки поставки, возможна ускоренная поставка.
- Доставку товара в любую точку России и стран СНГ.
- Комплексную поставку.
- Работу по проектам и поставку образцов.
- Формирование склада под заказчика.
- Сертификаты соответствия на поставляемую продукцию (по желанию клиента).
- Тестирование поставляемой продукции.
- Поставку компонентов, требующих военную и космическую приемку.
- Входной контроль качества.
- Наличие сертификата ISO.

В составе нашей компании организован Конструкторский отдел, призванный помогать разработчикам, и инженерам.

Конструкторский отдел помогает осуществить:

- Регистрацию проекта у производителя компонентов.
- Техническую поддержку проекта.
- Защиту от снятия компонента с производства.
- Оценку стоимости проекта по компонентам.
- Изготовление тестовой платы монтаж и пусконаладочные работы.



Тел: +7 (812) 336 43 04 (многоканальный)

Email: org@lifeelectronics.ru