

Specification

40 - Gbps QSFP+ Pluggable

Optical Transceiver Module

40GBASE-PSM4



Ordering Information

T Q S - Q 1 L B 9 - F 1 1

Model Name	Voltage	Category	Device type	Interface	Temperature	Distance	Latch Color
TQS-Q1LB9-FC1	3.3V	With DDMI	DFB / PIN	CML/CML	+0°C~+70°C	2m-10km	Yellow 

Features

- Compliant to QSFP+ MSA (SFF-8436)
- Up to 11.2Gbps data rate per channel
- MPO optical connector (IEC61754-7-1)
- Transmission length up to 10km
- Transmitter: 4 channel PIN photo detector
- Operating case temperature: 0~70°C
- Low power consumption: 2W max
- I2C interface for management signal
- RoHS-6 compliant

Applications

- Switch Router and HBA's
- 40G Ethernet
- Infiniband QDR, DDR and SDR
- High-performance Backplane
- Datacenter and Enterprise networking

Transceiver Block Diagram

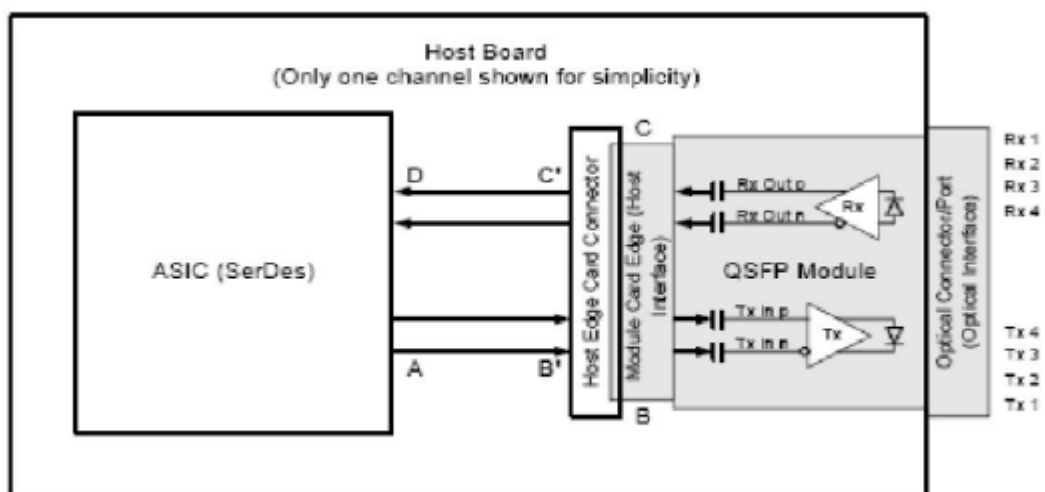

Figure 1 - Application Reference Model

General Description

The TQS-Q1LB9-F11 is a parallel 40Gbps Quad Small Form-factor Pluggable (QSFP) optical module. It provides increased port density and total system cost savings. The QSFP full-duplex optical module offers 4 independent transmit and receive channels, each capable of 10.3125Gbps operation for an aggregate data rate of 41.25Gbps 10km of single mode fiber.

An optical fiber ribbon cable with an MPO/MTPTM connector can be plugged into the QSFP module receptacle. Proper alignment is ensured by the guide pins inside the receptacle. The cable usually cannot be twisted for proper channel to channel alignment. Electrical connection is achieved through a z-pluggable 38-pin connector per MSA requirement.

The module operates with single +3.3V power supply. LVCMOS/LVTTL global control signals, such as Module Present, Reset, Interrupt and Low Power Mode, are available with the modules. A 2-wire serial interface is available to send and receive more complex control signals, and to receive digital diagnostic information. Individual channels can be addressed and unused channels can be shut down for maximum design flexibility.

The TQS-Q1LB9-F11 design is compliant to QSFP+ Multi-source agreement (MSA) in terms of form factor, optical/electrical connection and digital diagnostic interface. It has been designed to meet the harshest external operating conditions including temperature, humidity and EMI interference. The module can be managed through the I2C two-wire serial interface.

Functional Description

The TQS-Q1LB9-F11 is a full-duplex optical transceiver. The transmitter module accepts electrical input signals compatible with Common Mode Logic (CML) levels. All input data signals are differential and internally terminated. The receiver module converts parallel optical input signals via a photo detector array into parallel electrical output signals. The receiver module outputs electrical signals are also voltage compatible with Common Mode Logic (CML) levels. All data signals are differential and support a data rates up to 10.3Gbps per channel.

Per MSA the module offers 7 low speed hardware control pins (including the 2-wire serial interface): ModSelL, SCL, SDA, ResetL, LPMode, ModPrsL and IntL.

Module Select (ModSelL) is an input pin. When held low by the host, the module responds to 2-wire serial communication commands. The ModSelL allows the use of multiple QSFP modules on a single 2-wire interface bus – individual ModSelL lines for each QSFP module must be used.

Serial Clock (SCL) and Serial Data (SDA) are required for the 2-wire serial bus communication interface and enable the host to access the QSFP memory map.

The ResetL pin enables a complete module reset, returning module settings to their default state, when a low level on the ResetL pin is held for longer than the minimum pulse length. During the execution of a reset the host shall disregard all status bits until the module indicates a completion of the reset interrupt. The module indicates this by posting an IntL (Interrupt) signal with the Data_Not_Ready bit negated in the memory map. Note that on power up (including hot insertion) the module should post this completion of reset interrupt without requiring a reset.

Low Power Mode (LPMode) pin is used to set the maximum power consumption for the module in order to protect hosts that are not capable of cooling higher power modules, should such modules be accidentally inserted.

Module Present (ModPrsL) is a signal local to the host board which, in the absence of a module, is normally pulled up to the host Vcc. When a module is inserted into the connector, it completes the path to ground through a resistor on the host board and asserts the signal. ModPrsL then indicates a module is present by setting ModPrsL to a “Low” state.

Interrupt (IntL) is an output pin. Low indicates a possible module operational fault or a status critical to the host system. The host identifies the source of the interrupt using the 2-wire serial interface. The IntL pin is an open collector output and must be pulled to the Host Vcc voltage on the Host board.

Pin Assignment and Pin Description

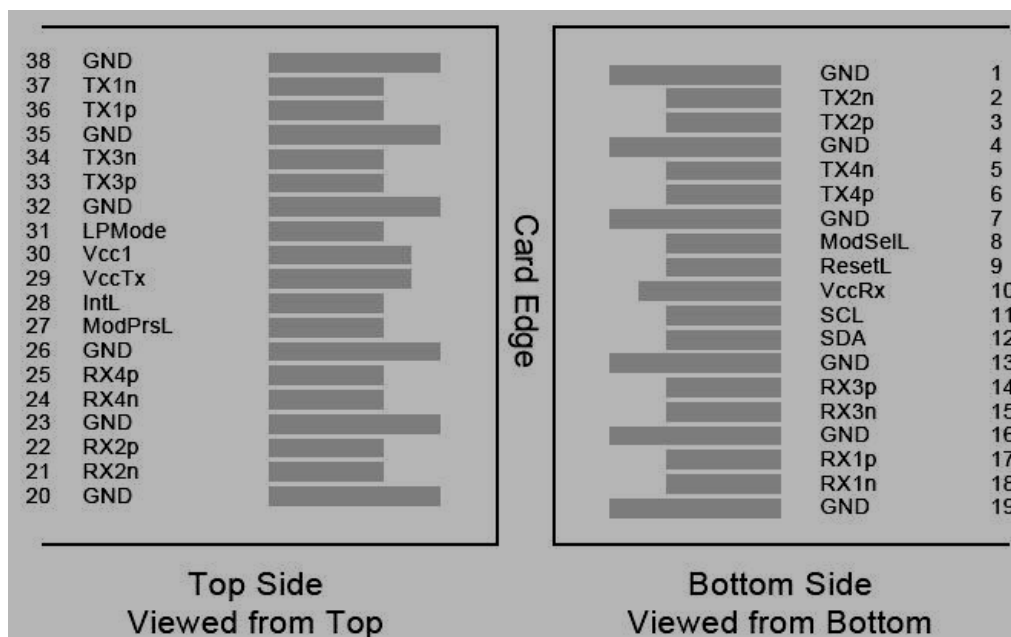

Pin Definitions

PIN	Logic	Symbol	Name/Description	Note
1		GND	Ground	1
2	CML-I	Tx2n	Transmitter Inverted Data Input	
3	CML-I	Tx2p	Transmitter Non-Inverted Data output	
4		GND	Ground	1
5	CML-I	Tx4n	Transmitter Inverted Data Input	
6	CML-I	Tx4p	Transmitter Non-Inverted Data output	
7		GND	Ground	1
8	LVTTL-I	ModSelL	Module Select	
9	LVTTL-I	ResetL	Module Reset	
10		VccRx	+ 3.3V Power Supply Receiver	2
11	LVC MOS-I/O	SCL	2-Wire Serial Interface Clock	
12	LVC MOS-I/O	SDA	2-Wire Serial Interface Data	
13		GND	Ground	
14	CML-O	Rx3p	Receiver Non-Inverted Data Output	
15	CML-O	Rx3n	Receiver Inverted Data Output	
16		GND	Ground	1
17	CML-O	Rx1p	Receiver Non-Inverted Data Output	
18	CML-O	Rx1n	Receiver Inverted Data Output	
19		GND	Ground	1
20		GND	Ground	1
21	CML-O	Rx2n	Receiver Inverted Data Output	
22	CML-O	Rx2p	Receiver Non-Inverted Data Output	
23		GND	Ground	1
24	CML-O	Rx4n	Receiver Inverted Data Output	1
25	CML-O	Rx4p	Receiver Non-Inverted Data Output	
26		GND	Ground	1
27	LVTTL-O	ModPrsL	Module Present	
28	LVTTL-O	IntL	Interrupt	
29		VccTx	+3.3 V Power Supply transmitter	2
30		Vcc1	+3.3 V Power Supply	2
31	LVTTL-I	LPMODE	Low Power Mode	
32		GND	Ground	1

33	CML-I	Tx3p	Transmitter Non-Inverted Data Input	
34	CML-I	Tx3n	Transmitter Inverted Data Output	
35		GND	Ground	1
36	CML-I	Tx1p	Transmitter Non-Inverted Data Input	
37	CML-I	Tx1n	Transmitter Inverted Data Output	
38		GND	Ground	1

Notes:

1. GND is the symbol for signal and supply (power) common for QSFP modules. All are common within the QSFP module and all module voltages are referenced to this potential unless otherwise noted. Connect these directly to the host board signal common ground plane.
2. VccRx, Vcc1 and VccTx are the receiving and transmission power suppliers and shall be applied concurrently. Recommended host board power supply filtering is shown below. VccRx, Vcc1 and VccTx may be internally connected within the QSFP transceiver module in any combination. The connector pins are each rated for a maximum current of 500mA.

Absolute Maximum Ratings

Parameter	Symbol	Min	Max	Unit	Note
Storage Temperature	Tst	-40	85	degC	
Relative Humidity (non-condensation)	RH	0	85	%	
Operating Case Temperature	Topc	0	70	degC	
Supply Voltage	VCC	0	3.8	V	

Recommended Operating Environment and Power Supply Characteristics

Parameter	Symbol	Min	Max	Unit	Note
Case Operating Temperature Range	T _c	0	25	70	°C
Power Supply Voltage	V _{cc}	3.15	3.30	3.45	V
Power Supply Current	I _{cc}			720	mA
Power Consumption				2.0	W
Data Rate			10.3125		Gbps
Data Speed Tolerance	ΔDR	-100		+100	ppm
Link Distance with G652	D	0.002		10	km

Electrical Characteristics

Parameter	Symbol	Min	Typ.	Max	Unit	Note
Transmitter						
Differential Input Impedance		90	100	110	Ω	
Differential Input Swing		200		800	mV	
TP1/TP1a Interface	Compliant to IEEE 802.3ba XLPPI					
Receiver						
Differential Output Impedance		90	100	110	Ω	
Differential Output Swing		400	600	850	mV	
TP4 Interface	Compliant to IEEE 802.3ba XLPPI					

Optical Characteristics

Parameter	Symbol	Min.	Typ.	Max.	Unit	Notes
Transmitter						
Center wavelength	λ_c	1260	1310	1360	nm	1
Side Mode Suppression Ratio	SMSR	30			dB	
Average Launch Power, each lane	P_{AVG}	-8.2	-2.5	+0.5	dBm	
Optical Modulation Amplitude (OMA)	P_{OMA}	-5.2	-2.5	+2.0	dBm	1
Difference in Launch Power between any two lanes	$P_{tx, diff}$			5.0	dB	
Launch Power in OMA minus Transmitter and Dispersion Penalty (TDP), each lane	OMA-TDP	-9.7			dBm	1
Extinction ratio	ER	3.5			dB	
Relative intensity Noise	R_{in}			-128	dB/Hz	
Optical Return Loss Tolerance	TOL			12	dB	
Transmitter Eye Mask Margin	EMM	5			%	2
Average Launch Power OFF Transmitter, each lane	P_{off}			-30	dBm	
Transmitter Eye Mask Definition (X1, X2, X3, Y1, Y2, Y3)		0.25, 0.4, 0.45, 0.25, 0.28, 0.4				

Note:

1. The receiver shall be able to tolerate, without damage, continuous exposure to a modulated optical input signal having this power level on one lane. The receiver does not have to operate correctly at this input power.
2. Vertical eye closure penalty and stressed eye jitter are test conditions for measuring stressed receiver sensitivity. They are not characteristics of the receiver.

Parameter	Symbol	Min.	Typ.	Max.	Unit	Notes
Receiver						
Center wavelength	λ_c	1260	1310	1360	nm	
Damage Threshold	TH _d	+3			dBm	
Overload, each lane	OVL	+0.5			dBm	
Receiver Sensitivity in OMA, each lane	SEN			-126	dBm	
Signal Loss Assert Threshold	LOSA	-30			dBm	
Signal Loss Deassert Threshold	LOSD			-15	dBm	
LOS Hysteresis	LOSH	0.5		6	dBm	

Digital Diagnostic Monitor Functions

Parameter	Symbol	Min.	Max.	Unit	Notes
Temperature monitor absolute error	DMI_Temp	-3	+3	degC	Over operating temp
Supply voltage monitor absolute error	DMI_VCC	-0.1	0.1	V	Full operating range
Channel RX power monitor absolute error	DMI_RX_Ch	-3	+3	dB	Ch1~Ch4
Channel Bias current monitor	DMI_Ibias_Ch	-10%	+10%	mA	Ch1~Ch4
Channel TX power monitor absolute error	DMI_TX_Ch	-3	+3	dB	Ch1~Ch4

MPO Fiber Definitions

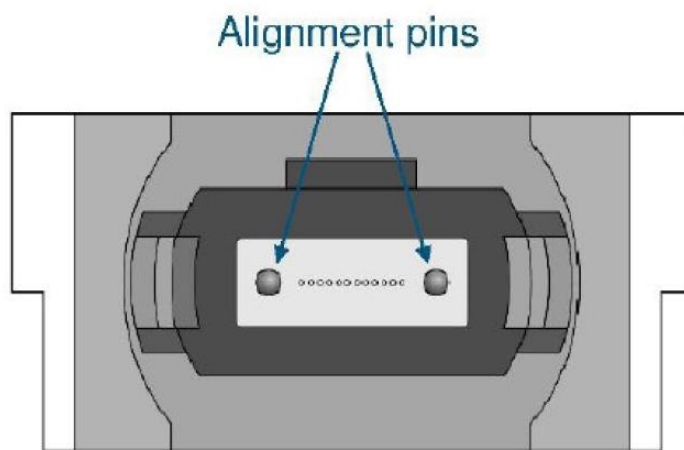

Transmit Channels: 1 2 3 4
 Unused positions: x x x x
 Receive Channels: 4 3 2 1

Address	Description	Hex	Real Value
128	Identifier	0D	QSFP+
129	Ext. Identifier	40	Power Class 2 Module; No CLEI code present in Page 02h; No CDR in TX and RX
130	Connector	0C	MPO Connector
131	Specification Compliance	02	40GBASE-LR4
132		00	Not compliant
133		00	Not compliant
134		00	Not compliant
135		00	Not compliant
136		00	Not compliant
137		00	Not compliant
138		00	Not compliant
139	Encoding	05	64B66B
140	BR, nominal	67	10.3Gbps
141	Extended rate select Compliance	00	Not compliant
142	Length(SMF)	0A	10km
143	Length(OM3 50 um)	00	Not compliant
144	Length(OM2 50 um)	00	Not compliant
145	Length(OM1 62.5 um)	00	Not compliant
146	Length(Copper)	00	Not compliant
147	Device tech	40	1310nm DFB; No wavelength control; Uncooled transmitter device; Pin detector; Transmitter not tunable
148-163	Vendor name	46,4F,52,4D,45,52,49,43, 41,4F,45,20,20,20,20,20	FORMERICA OE
164	Extended Module	00	
165-167	Vendor OUI	00, 00, 00	
168-183	Vendor PN	54,51,53,2D,51,31,4C,42, 39,2D,46,31,31,20,20,20	TQS-Q1LB9-F11
184-185	Vendor rev	00, 00	
186-187	Wave length or Copper cable Attenuation	66, 58	1310nm
188-189	Wavelength tolerance	27, 10	±50nm
190	Max case temp.	46	70°C
191	CC_BASE		Check sum of byte 128 ~ 190
192-195	Options	12, 00, 00, 00	
196-211	Vendor SN		
212-219	Date Code		
220	Diagnostic Monitoring Type	08	Average Power
221	Enhanced Options	00	
222	Reserved	00	
223	CC_EXT		Check sum of byte 192 ~ 222
224-255	Vendor Specific		

Address	Description	Hex	Real Value
128-129	Temp high alarm	50, 00	80°C
130-131	Temp low alarm	F6, 00	-10°C
132-133	Temp high warning	4B, 00	75°C
134-135	Temp low warning	FB, 00	-5°C
144-145	Vcc high alarm	90, 88	3.7V
146-147	Vcc low alarm	71, 70	2.9V
148-149	Vcc high warning	8C, 70	3.6V
150-151	Vcc low warning	75, 48	3.0V
176-177	Rx power high alarm	6E, 18	4.5dBm
178-179	Rx power low alarm	00, E5	-16.4dBm
180-181	Rx power high warning	45, 77	2.5dBm
182-183	Rx power low warning	01, 6B	-14.4dBm
184-185	Tx bias high alarm	92, 7C	75mA
186-187	Tx bias low alarm	13, 88	10mA
188-189	Tx bias high warning	88, B8	70mA
190-191	Tx bias low warning	1D, 4C	15mA

Mechanical Design Diagram

Unit: mm

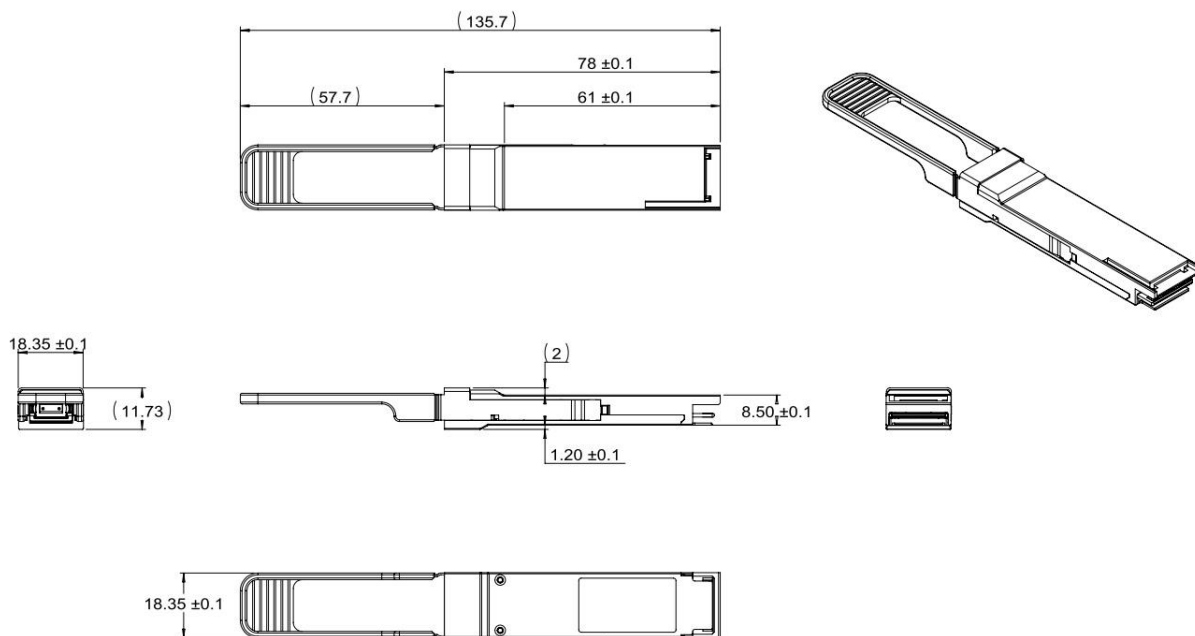

Attention: Attention: To minimize MPO connection induced reflections, an MPO receptacle with 8-degree angled end-face is utilized for this product. A male MPO connector with 8-degree end-face should be used with this product as illustrated in below.

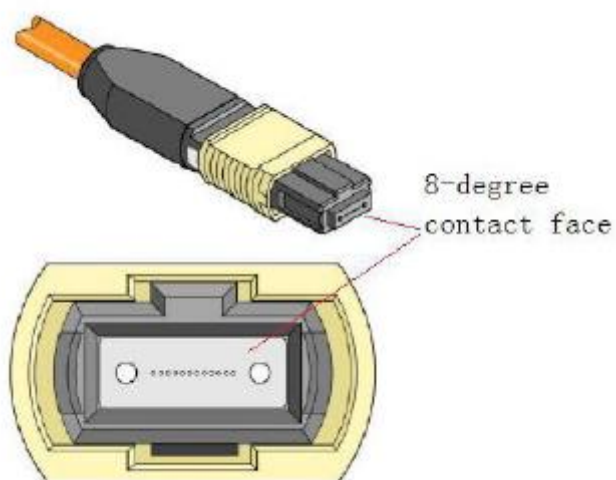

ESD

This transceiver is specified as ESD threshold 1kV for SFI pins and 2KV for all others electrical input pins, tested per MIL-STD-883, Method 3015.4 /JESD22-A114-A (HBM). However, normal ESD precautions are still required during the handling of this module. This transceiver is shipped in ESD protective packaging. It should be removed from the packaging and handled only in an ESD protected environment.

Laser Safety

This is a Class 1 Laser Product according to IEC 60825-1:1993:+A1:1997+A2:2001. This product complies with 21 CFR 1040.10 and 1040.11 except for deviations pursuant to Laser Notice No. 50, dated (June 24, 2007)

Компания «Life Electronics» занимается поставками электронных компонентов импортного и отечественного производства от производителей и со складов крупных дистрибьюторов Европы, Америки и Азии.

С конца 2013 года компания активно расширяет линейку поставок компонентов по направлению коаксиальный кабель, кварцевые генераторы и конденсаторы (керамические, пленочные, электролитические), за счёт заключения дистрибьюторских договоров

Мы предлагаем:

- Конкурентоспособные цены и скидки постоянным клиентам.
- Специальные условия для постоянных клиентов.
- Подбор аналогов.
- Поставку компонентов в любых объемах, удовлетворяющих вашим потребностям.
- Приемлемые сроки поставки, возможна ускоренная поставка.
- Доставку товара в любую точку России и стран СНГ.
- Комплексную поставку.
- Работу по проектам и поставку образцов.
- Формирование склада под заказчика.
- Сертификаты соответствия на поставляемую продукцию (по желанию клиента).
- Тестирование поставляемой продукции.
- Поставку компонентов, требующих военную и космическую приемку.
- Входной контроль качества.
- Наличие сертификата ISO.

В составе нашей компании организован Конструкторский отдел, призванный помогать разработчикам, и инженерам.

Конструкторский отдел помогает осуществить:

- Регистрацию проекта у производителя компонентов.
- Техническую поддержку проекта.
- Защиту от снятия компонента с производства.
- Оценку стоимости проекта по компонентам.
- Изготовление тестовой платы монтаж и пусконаладочные работы.



Тел: +7 (812) 336 43 04 (многоканальный)

Email: org@lifeelectronics.ru