



## SY898533L

### Precision Differential 3.3V Low Skew LVPECL 1:4 Fanout Buffer

## General Description

The SY898533L is a 3.3V, low skew, 1:4 LVPECL fanout buffer with two selectable clock input pairs. Most standard differential input levels can be applied to the CLK, /CLK pair while LVPECL, CML, or SSTL input levels can be applied to the PCLK, /PCLK pair. To eliminate runt pulses on the outputs during asynchronous assertion/de-assertion of the clock enable pin, the clock enable is synchronized with the input signal.

The SY898533L operates from a 3.3V  $\pm 5\%$  supply and is guaranteed over the full industrial temperature range of 0°C to +70°C. The SY898533L is part of Micrel's high-speed, Precision Edge<sup>®</sup> product line.

Datasheets and support documentation can be found on Micrel's web site at: [www.micrel.com](http://www.micrel.com).



Precision Edge<sup>®</sup>

## Features

- Provides four differential 3.3V LVPECL copies
- Selects between differential CLK, /CLK or LVPECL clock inputs
- CLK, /CLK pair accepts LVDS, LVPECL, LVHSTL, SSTL, HCSL input levels
- PCLK, /PCLK pair accepts LVPECL, CML, SSTL input levels
- Guaranteed AC performance over temperature and supply voltage:
  - 650MHz Maximum output frequency
  - < 1.4ns Propagation delay (In-to-Q)
  - < 30ps Output skew
  - < 150ps Part-to-part skew
  - Additive phase jitter, RMS: 0.06ps (typical)
- 3.3V  $\pm 5\%$  supply voltage
- 0°C to +70°C temperature operating range
- Available in a 20-pin TSSOP package

## Functional Block Diagram

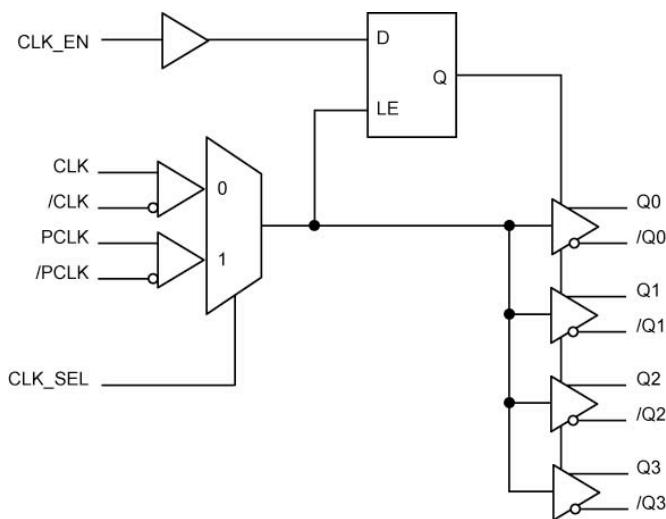

## Applications

- SONET clock distribution
- Backplane distribution

## Markets

- LAN/WAN
- Enterprise servers
- ATE
- Test and measurement

Precision Edge is a registered trademark of Micrel, Inc.

Micrel Inc. • 2180 Fortune Drive • San Jose, CA 95131 • USA • tel +1 (408) 944-0800 • fax + 1 (408) 474-1000 • <http://www.micrel.com>

July 2009

M9999-072409-C  
[hbwhelp@micrel.com](mailto:hbwhelp@micrel.com) or (408) 955-1690

## Ordering Information

Part Number	Package Type	Operating Range	Package Marking	Lead Finish
SY898533LKZ	K4-20-1	Commercial	SY898533 with Pb-Free bar-line Indicator	Matte-tin Pb-Free
SY898533LKZTR <sup>(2)</sup>	K4-20-1	Commercial	SY898533 with Pb-Free bar-line Indicator	Matte-tin Pb-Free

**Notes:**

1. Contact factory for die availability. Dice are guaranteed at T<sub>A</sub> = 25°C, DC Electricals Only.
2. Tape and Reel.

## Pin Configuration

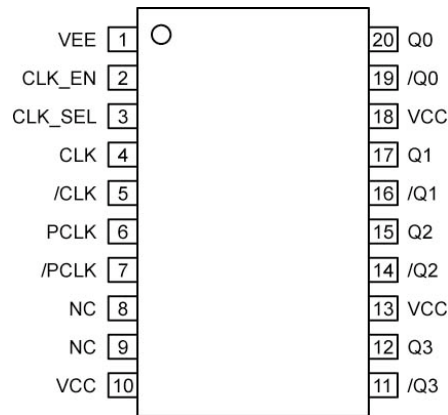

20-Pin TSSOP (K4-20-1)

## Pin Description

Pin Number	Pin Name	Pin Function
1	V <sub>EE</sub>	Ground.
2	CLK_EN	Single-Ended Input: This TTL/CMOS input disables and enables the Q0-Q3 outputs. It is internally connected to a 50kΩ pull-up resistor and will default to a logic HIGH state if left open. When disabled, Q goes LOW and /Q goes HIGH. CLK_EN being synchronous, outputs will be enabled/disabled following a rising and a falling edge of the input clock. V <sub>TH</sub> = is approximately 1.5V.
3	CLK_SEL	Single-Ended Input: This single-ended TTL/CMOS-compatible input selects the input to the multiplexer. Note that this input is internally connected to a 50kΩ pull-down resistor and will default to logic LOW state if left open. V <sub>TH</sub> = is approximately 1.5V.
4, 5	CLK, /CLK	Differential Input: This input pair is a differential signal input to the device. This input accepts AC- or DC-coupled signals. CLK is internally connected to a 28kΩ pull-down resistor and will default to a logic LOW state if left open while /CLK is connected to a 50kΩ pull-up resistor and will default to a logic HIGH state if left open. This input pair is selected when CLK_SEL is set to logic LOW.
6, 7	PCLK, /PCLK	Differential Input: This input pair is a differential signal input to the device. This input accepts AC- or DC-coupled signals. PCLK is internally connected to a 50kΩ pull-down resistor and will default to a logic LOW state if left open while /PCLK is connected to a 50kΩ pull-up resistor and will default to a logic HIGH state if left open. This input pair is selected when CLK_SEL is set to logic HIGH.
8, 9	NC	Unused Pins
10, 13, 18	V <sub>CC</sub>	Positive Power Supply Pins: Bypass with 0.1μF  0.01μF low ESR capacitors as close to the V <sub>CC</sub> pins as possible.
20, 19 17, 16 15, 14 12, 11	Q0, /Q0 Q1, /Q1 Q2, /Q2 Q3, /Q3	LVPECL Differential Output Pairs: Differential buffered output copies of the selected input signal. The output swing is typically 800mV. Unused output pairs may be left floating with no impact on jitter. These differential LVPECL outputs are a logic function of the CLK, /CLK and PCLK, /PCLK, and CLK_SEL inputs. See "Truth Table" below.

## Truth Table

Inputs			Outputs	
CLK_EN	CLK_SEL	Selected Source	Q0 :Q3	/Q0:/Q3
0	0	CLK, /CLK	Disabled : LOW	Disabled : HIGH
0	1	PCLK, /PCLK	Disabled : LOW	Disabled : HIGH
1	0	CLK, /CLK	CLK	/CLK
1	1	PCLK, /PCLK	PCLK	/PCLK

**Absolute Maximum Ratings<sup>(1)</sup>**

Supply Voltage ( $V_{CC}$ )	-0.5V to +4.6V
Input Voltage ( $V_{IN}$ )	-0.5V to $V_{CC} + 0.5V$
LVPECL Output Current ( $I_{OUT}$ )	
Continuous	50mA
Surge	100mA
Lead Temperature (soldering, 20 sec.)	+260°C
Storage Temperature ( $T_s$ )	-65°C to 150°C

**Operating Ratings<sup>(2)</sup>**

Supply Voltage ( $V_{CC}$ )	+3.135V to +3.465V
Ambient Temperature ( $T_A$ )	0°C to +70°C
Package Thermal Resistance <sup>(3)</sup>	
TSSOP ( $\theta_{JA}$ )	
Still-Air	73.2°C/W

**Power Supply DC Electrical Characteristics<sup>(4)</sup>**

$V_{CC} = 3.3V \pm 5\%$ ;  $T_A = 0^\circ C$  to +70°C, unless otherwise stated.

Symbol	Parameter	Condition	Min	Typ	Max	Units
$V_{CC}$	Power Supply		3.135	3.3	3.465	V
$I_{EE}$	Power Supply Current	No load, max $V_{CC}$			50	mA

**LVC MOS/LVTTL DC Electrical Characteristics<sup>(4)</sup>**

$V_{CC} = 3.3V \pm 5\%$ ;  $T_A = 0^\circ C$  to +70°C, unless otherwise stated.

Symbol	Parameter	Condition	Min	Typ	Max	Units
$V_{IH}$	Input High Voltage		2		$V_{CC} + 0.3V$	V
$V_{IL}$	Input Low Voltage		-0.3		0.8	V
$I_{IH}$	Input High Current	CLK_EN $V_{IN} = V_{CC} = 3.465V$			5	$\mu A$
		CLK_SEL $V_{IN} = V_{CC} = 3.465V$			150	$\mu A$
$I_{IL}$	Input Low Current	CLK_EN $V_{IN} = 0V, V_{CC} = 3.465V$	-150			$\mu A$
		CLK_SEL $V_{IN} = 0V, V_{CC} = 3.465V$	-5			$\mu A$

**Differential DC Electrical Characteristics<sup>(4)</sup>**

$V_{CC} = 3.3V \pm 5\%$ ;  $T_A = 0^\circ C$  to +70°C, unless otherwise stated.

Symbol	Parameter	Condition	Min	Typ	Max	Units
$I_{IH}$	Input High Current	CLK $V_{IN} = V_{CC} = 3.465V$			150	$\mu A$
		/CLK $V_{IN} = V_{CC} = 3.465V$			5	$\mu A$
$I_{IL}$	Input Low Current	CLK $V_{IN} = 0.5V, V_{CC} = 3.465V$	-5			$\mu A$
		/CLK $V_{IN} = 0.5V, V_{CC} = 3.465V$	-150			$\mu A$
$V_{PP}$	Peak-to-Peak Input Voltage		0.15		1.3	V
$V_{CMR}$	Common Mode Input Voltage <sup>(5, 6)</sup>		$V_{EE} + 0.5$		$V_{CC} - 0.85$	V

**Notes:**

1. Permanent device damage may occur if absolute maximum ratings are exceeded. This is a stress rating only and functional operation is not implied at conditions other than those detailed in the operational sections of this data sheet. Exposure to absolute maximum rating conditions for extended periods may affect device reliability.
2. The data sheet limits are not guaranteed if the device is operated beyond the operating ratings.
3.  $\theta_{JA}$  value is determined for a 4-layer board in still air unless otherwise stated.
4. The circuit is designed to meet the DC specifications shown in the above table after thermal equilibrium has been established.
5. Maximum input voltage for PCLK and /PCLK is  $V_{CC} + 0.3V$  for single ended applications.
6.  $V_{IH}$  is defined as the common mode voltage.

## LVPECL DC Electrical Characteristics<sup>(7)</sup>

$V_{CC} = 3.3V \pm 5\%$ ;  $T_A = 0^\circ C$  to  $+70^\circ C$ , unless otherwise stated.

Symbol	Parameter	Condition	Min	Typ	Max	Units
I <sub>IH</sub>	Input High Current	PCLK $V_{IN} = V_{CC} = 3.465V$			150	$\mu A$
		/PCLK $V_{IN} = V_{CC} = 3.465V$			5	$\mu A$
I <sub>IL</sub>	Input Low Current	PCLK $V_{IN} = 0V, V_{CC} = 3.465V$	-5			$\mu A$
		/PCLK $V_{IN} = 0V, V_{CC} = 3.465V$	-150			$\mu A$
V <sub>PP</sub>	Peak-to-Peak Input Voltage		0.3		1	V
V <sub>CMR</sub>	Common Mode Input Voltage <sup>(8, 9)</sup>		$V_{EE} + 1.5$		$V_{CC}$	V
V <sub>OH</sub>	Output High Voltage <sup>(10)</sup>		$V_{CC} - 1.4$		$V_{CC} - 0.9$	V
V <sub>OL</sub>	Output Low Voltage <sup>(10)</sup>		$V_{CC} - 2.0$		$V_{CC} - 1.7$	V
V <sub>SWING</sub>	Peak-to-Peak Output Voltage Swing		0.6		1.0	V

### Notes:

- The circuit is designed to meet the DC specifications shown in the above table after thermal equilibrium has been established.
- Maximum input voltage for PCLK and /PCLK is  $V_{CC} + 0.3V$  for single ended applications.
- $V_{IH}$  is defined as the common mode voltage.
- 50 $\Omega$  to  $V_{CC}-2V$  terminated outputs.

## AC Electrical Characteristics<sup>(11)</sup>

$V_{CC} = 3.3V \pm 5\%$ ;  $R_L = 50\Omega$  to  $V_{CC}-2V$ ;  $T_A = 0^\circ C$  to  $+70^\circ C$ , unless otherwise stated.

Symbol	Parameter	Condition	Min	Typ	Max	Units
f <sub>MAX</sub>	Maximum Operating Frequency		650			MHz
t <sub>PD</sub>	Differential Propagation Delay IN-to-Q	$f \leq 650MHz$	1.0		1.4	ns
t <sub>SKEW</sub>	Output-to-Output Skew <sup>(12)</sup>				30	ps
	Part-to-Part Skew <sup>(13)</sup>				150	ps
t <sub>JITTER</sub>	Additive Phase Jitter <sup>(14)</sup>			0.06		ps <sub>RMS</sub>
t <sub>r</sub> , t <sub>f</sub>	Output Rise/Fall Time	20% to 80% @ 50MHz	300		700	ps
odc	Output Duty Cycle		47		53	%

### Notes:

- High-frequency AC-parameters are guaranteed by design and characterization.
- Output-to-Output skew is measured between two different outputs under identical transitions.
- Part-to-Part skew is defined for two parts with identical power supply voltages at the same temperature and with no skew of the edges at the respective inputs. This parameter is defined in accordance with JEDEC Standard 65.
- Driving only one input clock.

## Timing Diagrams

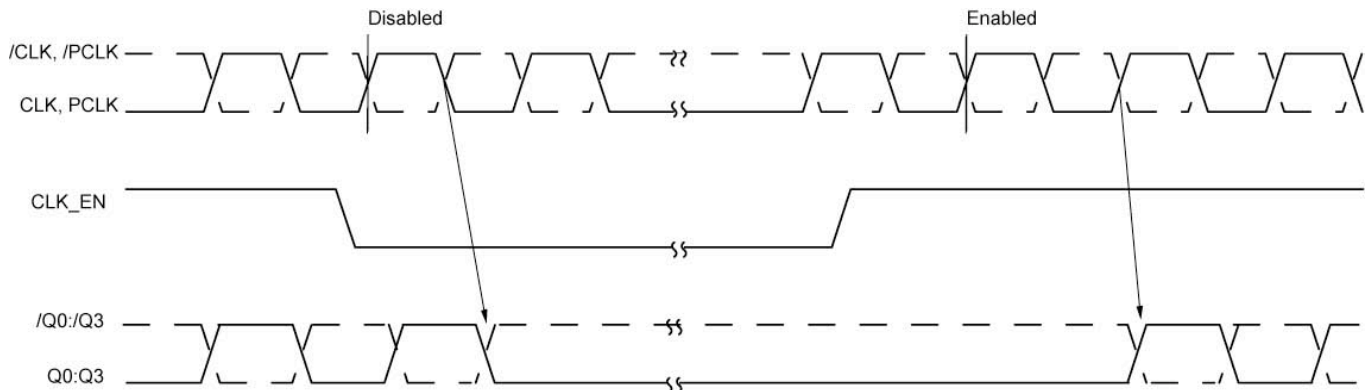

Figure 1a. CLK\_EN Timing Diagram

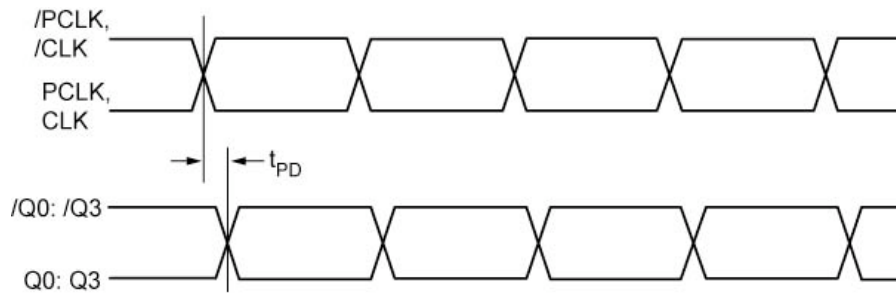

Figure 1b. Propagation Delay

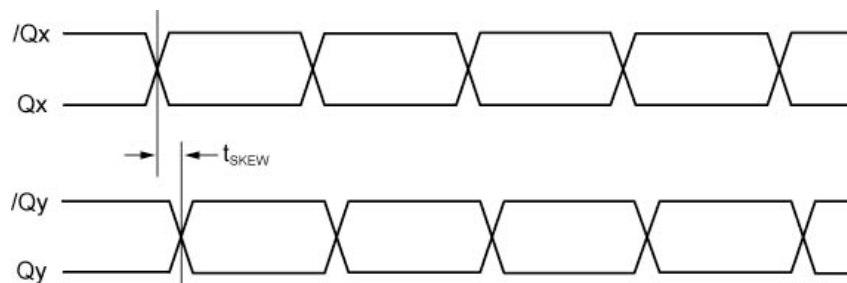
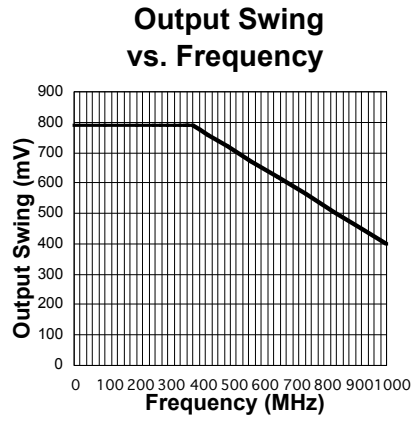

Figure 1c. Output-to-Output Skew

## Typical Operating Characteristics

$V_{CC} = 3.3V$ ,  $V_{EE} = 0V$ ,  $V_{IN} = 800mV$ ,  $R_L = 50\Omega$  to  $V_{CC}-2V$ ;  $T_A = 25^\circ C$ , unless otherwise stated.



## Functional Characteristics

$V_{CC} = 3.3V$ ,  $V_{EE} = 0V$ ,  $V_{IN} = 800mV$ ,  $R_L = 50\Omega$  to  $V_{CC}-2V$ ;  $T_A = 25^\circ C$ , unless otherwise stated

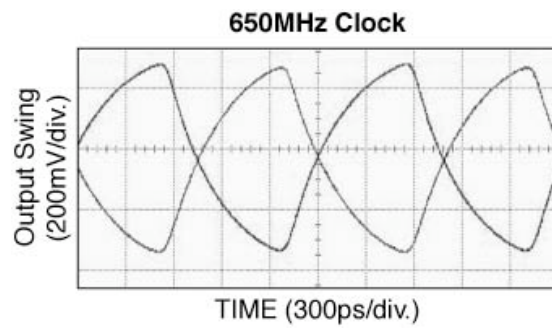
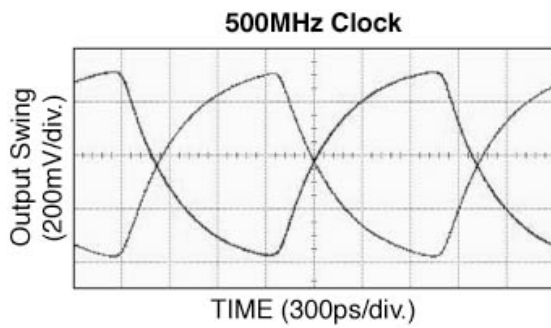
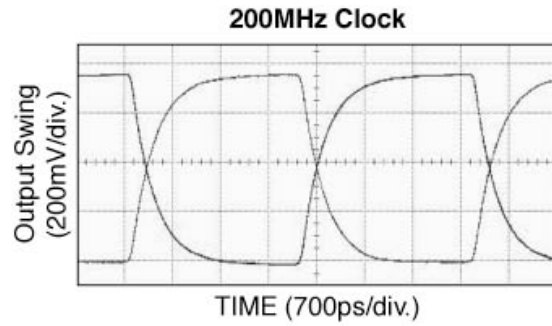
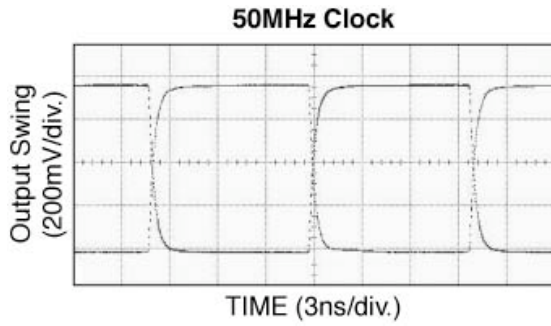



## CLK, /CLK Input Interface Applications

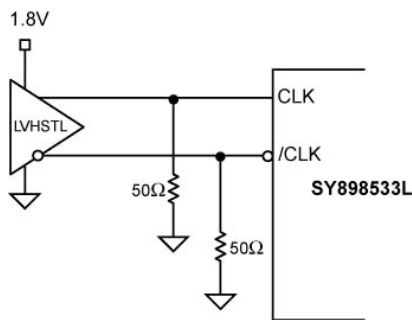

Figure 2a. LVHSTL Interface (DC-Coupled)

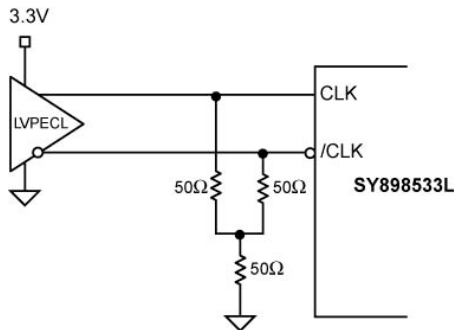

Figure 2b. LVPECL Interface (DC-Coupled)

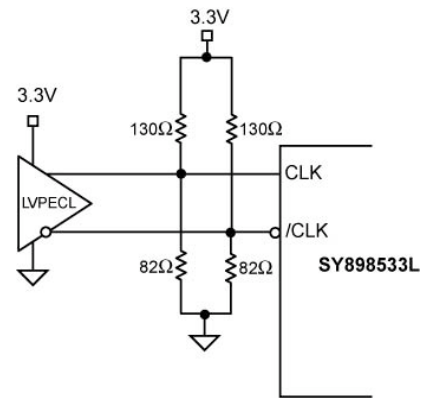

Figure 2c. LVPECL Interface (DC-Coupled)

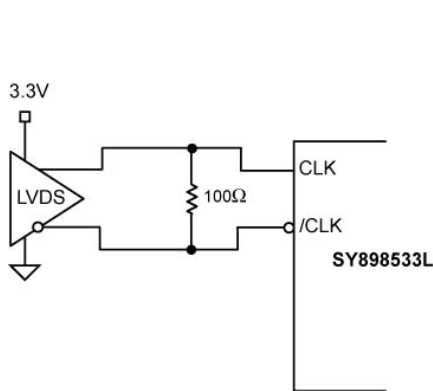

Figure 2d. LVDS Interface (DC-Coupled)

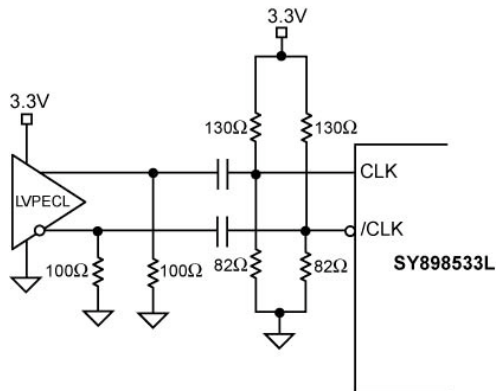

Figure 2e. LVPECL Interface (AC-Coupled)

## PCLK, /PCLK Input Interface Applications

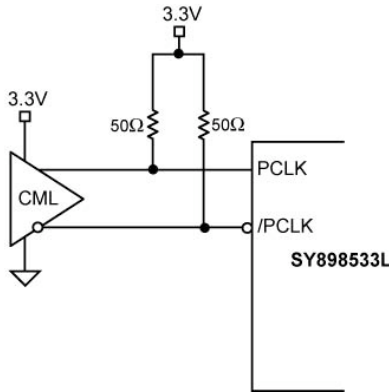

Figure 3a. CML Open Collector Interface (DC-Coupled)

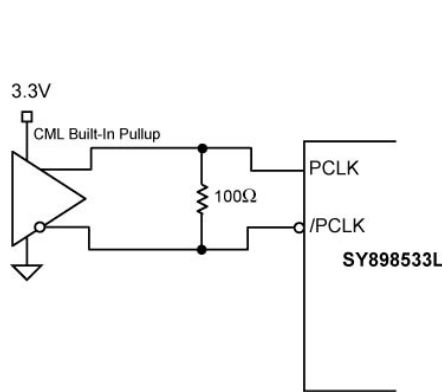

Figure 3b. CML Built-in Pull-up Interface (DC-Coupled)

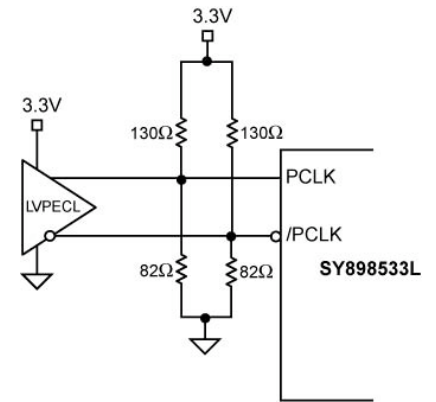

Figure 3c. LVPECL Interface (DC-Coupled)

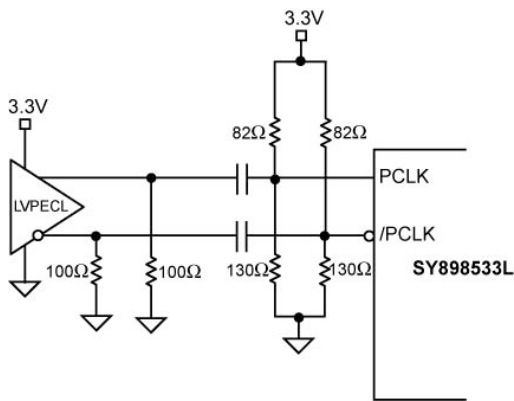

Figure 3d. LVPECL Interface (AC-Coupled)

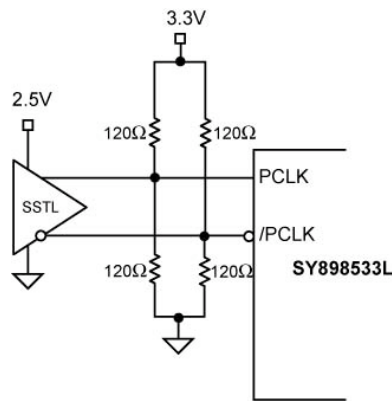

Figure 3e. SSTL Interface (DC-Coupled)

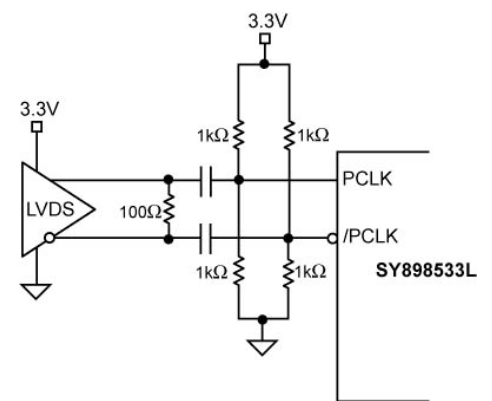
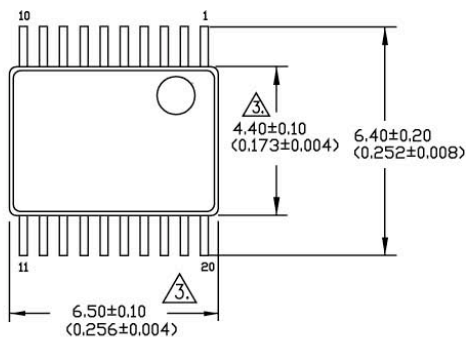
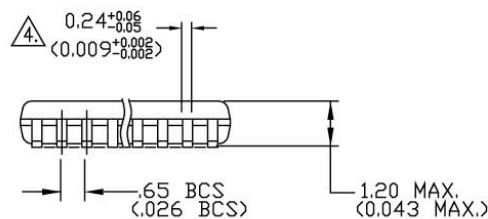

Figure 3f. LVDS Interface (AC-Coupled)

### Package Information



TOP VIEW



SIDE VIEW

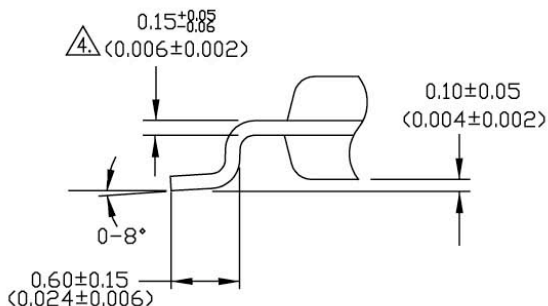

DETAIL 'A'  
(VIEW ROTATED 90° C.W.)

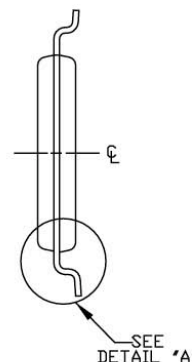

END VIEW

**NOTES:**

1. DIMENSIONS ARE IN MM[INCHES].
2. CONTROLLING DIMENSION: MM.
3. DIMENSION DOES NOT INCLUDE MOLD FLASH OF 0.254[0.010] MAX.
4. THIS DIMENSION INCLUDES LEAD FINISH.

**20-Pin TSSOP (K4-20-1)**

**MICREL, INC. 2180 FORTUNE DRIVE SAN JOSE, CA 95131 USA**  
 TEL +1 (408) 944-0800 FAX +1 (408) 474-1000 WEB <http://www.micrel.com>

The information furnished by Micrel in this data sheet is believed to be accurate and reliable. However, no responsibility is assumed by Micrel for its use. Micrel reserves the right to change circuitry and specifications at any time without notification to the customer.

Micrel Products are not designed or authorized for use as components in life support appliances, devices or systems where malfunction of a product can reasonably be expected to result in personal injury. Life support devices or systems are devices or systems that (a) are intended for surgical implant into the body or (b) support or sustain life, and whose failure to perform can be reasonably expected to result in a significant injury to the user. A Purchaser's use or sale of Micrel Products for use in life support appliances, devices or systems is a Purchaser's own risk and Purchaser agrees to fully indemnify Micrel for any damages resulting from such use or sale.

© 2009 Micrel, Incorporated.

Компания «Life Electronics» занимается поставками электронных компонентов импортного и отечественного производства от производителей и со складов крупных дистрибьюторов Европы, Америки и Азии.

С конца 2013 года компания активно расширяет линейку поставок компонентов по направлению коаксиальный кабель, кварцевые генераторы и конденсаторы (керамические, пленочные, электролитические), за счёт заключения дистрибьюторских договоров

Мы предлагаем:

- Конкурентоспособные цены и скидки постоянным клиентам.
- Специальные условия для постоянных клиентов.
- Подбор аналогов.
- Поставку компонентов в любых объемах, удовлетворяющих вашим потребностям.
- Приемлемые сроки поставки, возможна ускоренная поставка.
- Доставку товара в любую точку России и стран СНГ.
- Комплексную поставку.
- Работу по проектам и поставку образцов.
- Формирование склада под заказчика.
- Сертификаты соответствия на поставляемую продукцию (по желанию клиента).
- Тестирование поставляемой продукции.
- Поставку компонентов, требующих военную и космическую приемку.
- Входной контроль качества.
- Наличие сертификата ISO.

В составе нашей компании организован Конструкторский отдел, призванный помогать разработчикам, и инженерам.

Конструкторский отдел помогает осуществить:

- Регистрацию проекта у производителя компонентов.
- Техническую поддержку проекта.
- Защиту от снятия компонента с производства.
- Оценку стоимости проекта по компонентам.
- Изготовление тестовой платы монтаж и пусконаладочные работы.



Тел: +7 (812) 336 43 04 (многоканальный)  
Email: [org@lifeelectronics.ru](mailto:org@lifeelectronics.ru)