



Miniature I²C Digital Barometer

The MPL115A2 is an absolute pressure sensor with a digital I²C output targeting low cost applications. A miniature 5 by 3 by 1.2 mm LGA package is ideally suited for the space constrained requirements of portable electronic devices. Low current consumptions of 5 μ A during Active mode and 1 μ A during Shutdown (Sleep) mode are essential when focusing on low-power applications. The wide operating temperature range spans from -40°C to +105°C to fit demanding environmental conditions.

The MPL115A2 employs a MEMS pressure sensor with a conditioning IC to provide accurate pressure measurements from 50 to 115 kPa. An integrated ADC converts pressure and temperature sensor readings to digitized outputs via a I²C port. Factory calibration data is stored internally in an on-board ROM. Utilizing the raw sensor output and calibration data, the host microcontroller executes a compensation algorithm to render *Compensated Absolute Pressure* with ± 1 kPa accuracy.

The MPL115A2 pressure sensor's small form factor, low power capability, precision, and digital output optimize it for barometric measurement applications.

Features

- Digitized pressure and temperature information together with programmed calibration coefficients for host micro use.
- Factory Calibrated
- 50 kPa to 115 kPa Absolute Pressure
- ± 1 kPa Accuracy
- 2.375V to 5.5V Supply
- Integrated ADC
- I²C Interface (operates up to 400 kHz)
- 7 bit I²C address = 0x60
- Monotonic Pressure and Temperature Data Outputs
- Surface Mount RoHS Compliant Package

Application Examples

- Barometry (portable and desktop)
- Altimeters
- Weather Stations
- Hard Disk-Drives (HDD)
- Industrial Equipment
- Health Monitoring
- Air Control Systems

MPL115A2

50 to 115 kPa



MPL115A2

5.0 mm by 3.0 mm by 1.2 mm

Top View

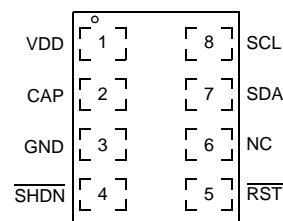

Pin Connections

ORDERING INFORMATION

Device Name	Package Options	Case No.	# of Ports			Pressure Type			Digital Interface
			None	Single	Dual	Gauge	Differential	Absolute	
MPL115A2	Tray	2015	•					•	I ² C
MPL115A2T1	Tape & Reel (1000)	2015	•					•	I ² C
MPL115A2T2	Tape & Reel (5000)	2015	•					•	I ² C

1 Block Diagram and Pin Descriptions

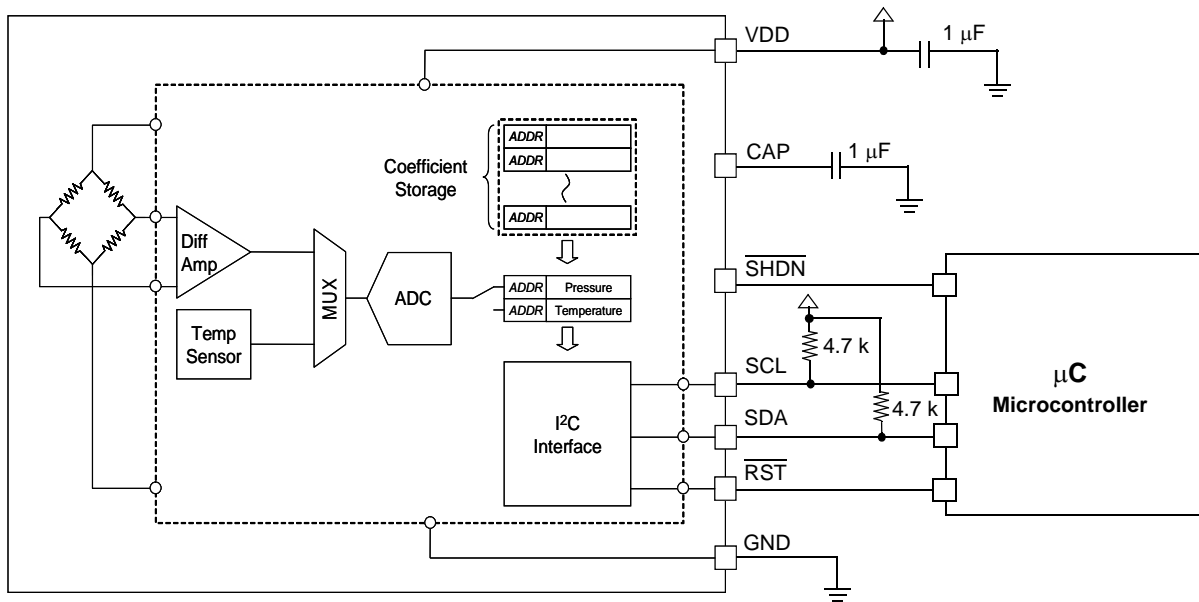

Figure 1. Block Diagram and Pin Connections

Table 1. Pin Description

Pin	Name	Function
1	VDD	VDD Power Supply Connection: VDD range is 2.375V to 5.5V.
2	CAP	1 μF connected to ground.
3	GND	Ground
4	$\overline{\text{SHDN}}$	Shutdown: Connect to GND to disable the device. When in shutdown, the part draws no more than 1 μA supply current and all communications pins (RST, SCL, SDA) are high impedance. Connect to VDD for normal operation.
5	$\overline{\text{RST}}$	Reset: Connect to ground to disable I ² C communications.
6	NC	NC: No connection
7	SDA ⁽¹⁾	SDA: Serial data I/O line
8	SCL ⁽¹⁾	I ² C Serial Clock Input.

1. Use 4.7k pullup resistors for I²C communication.

2 Mechanical and Electrical Specifications

2.1 Maximum Ratings

Voltage (with respect to GND unless otherwise noted)

V_{DD}	-0.3 V to +5.5 V
\overline{SHDN} , RST, SDA, SCL	-0.3 V to $V_{DD}+0.3$ V
Operating Temperature Range	-40°C to +105°C
Storage Temperature Range	-40°C to +125°C
Overpressure	1000 kPa

2.2 Operating Characteristics

V_{DD} = 2.375 V to 5.5 V, T_A = -40°C to +105°C, unless otherwise noted. Typical values are at V_{DD} = 3.3 V, T_A = +25°C.

Ref	Parameters	Symbol	Conditions	Min	Typ	Max	Units
1	Operating Supply Voltage	V_{DD}		2.375	3.3	5.5	V
2	Supply Current	I_{DD}	Shutdown (\overline{SHDN} = GND)	—	—	1	μ A
			Standby	—	3.5	10	μ A
			Average – at one measurement per second	—	5	6	μ A
Pressure Sensor							
3	Range			50	—	115	kPa
4	Resolution			—	0.15	—	kPa
5	Accuracy		-20°C to 85°C	—	—	± 1	kPa
6	Power Supply Rejection		Typical operating circuit at DC		0.1	—	kPa/V
			100 mV p-p 217 Hz square wave plus 100 mV pseudo random noise with 10 MHz bandwidth		0.1	—	kPa
7	Conversion Time (Start Pressure and Temperature Conversion)	t_c	Time between start convert command and data available in the Pressure and Temperature registers	—	1.6	3	ms
8	Wakeup Time	t_w	Time between leaving Shutdown mode (\overline{SHDN} goes high) and communicating with the device to issue a command or read data.	—	3	5	ms
I²C I/O Stages: SCL, SDA							
9	SCL Clock Frequency	f_{SCL}		—	—	400	kHz
10	Low Level Input Voltage	V_{IL}		—	—	$0.3V_{DD}$	V
11	High Level Input Voltage	V_{IH}		$0.7V_{DD}$	—	—	V
I²C Outputs: SDA							
12	Data Setup Time	t_{SU}	Setup time from command receipt to ready to transmit	0	—	0.4	s
I²C Addressing							
MPL115A2 uses 7-bit addressing, does not acknowledge the general call address 0000000. Slave address has been set to 0x60 or 1100000.							

3 Overview of Functions/Operation

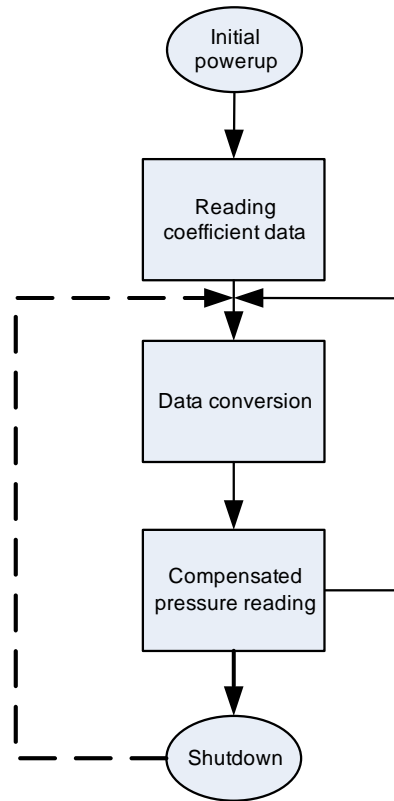

Figure 2. Sequence Flow Chart

The MPL115A interfaces to a host (or system) microcontroller in the user's application. All communications are via I²C. A typical usage sequence is as follows:

Initial Power-up

All circuit elements are active. I²C port pins are high impedance and associated registers are cleared. The device then enters standby mode.

Reading Coefficient Data

The user then typically accesses the part and reads the coefficient data. The main circuits within the slave device are disabled during read activity. The coefficients are usually stored in the host microcontroller local memory but can be re-read at any time.

It is not necessary to read the values stored in the host microcontroller multiple times because the coefficients within a device are constant and do not change. However, note that the coefficients will be different from device to device, and cannot be used for another part.

Data Conversion

This is the first step that is performed each time a new pressure reading is required which is initiated by the host sending the CONVERT command. The main system circuits are activated (wake) in response to the command and after the conversion completes, the result is placed into the Pressure and Temperature ADC output registers.

The conversion completes within the maximum conversion time, t_c (see [Row 7](#), in the Operating Characteristics Table). The device then enters standby mode.

Compensated Pressure Reading

After the conversion has been given sufficient time to complete, the host microcontroller reads the result from the ADC output registers and calculates the Compensated Pressure, a barometric/atmospheric pressure value which is compensated for changes in temperature and pressure sensor linearity. This is done using the coefficient data from the MPL115A and the raw sampled pressure and temperature ADC output values, in a compensation equation (detailed later). Note that this is an absolute pressure measurement with a vacuum as a reference.

From this step the host controller may either wait and then return to the Data Conversion step to obtain the next pressure reading or it may go to the Shutdown step.

Shutdown

For longer periods of inactivity the user may assert the $\overline{\text{SHDN}}$ input by driving this pin low to reduce system power consumption. This removes power from all internal circuits, including any registers. In the shutdown state, the Pressure and Temperature registers will be reset, losing any previous ADC output values.

This step is exited by taking the $\overline{\text{SHDN}}$ pin high. Wait for the maximum wakeup time, t_w (see [Row 8](#), in the Operating Characteristics Table), after which another pressure reading can be taken by transitioning to the data Conversion step.

Table 2. Device Memory Map

Address	Name	Description	Size (bits)
0x00	Padc_MSB	10-bit Pressure ADC output value MSB	8
0x01	Padc_LSB	10-bit Pressure ADC output value LSB	2
0x02	Tadc_MSB	10-bit Temperature ADC output value MSB	8
0x03	Tadc_LSB	10-bit Temperature ADC output value LSB	2
0x04	a0_MSB	a0 coefficient MSB	8
0x05	a0_LSB	a0 coefficient LSB	8
0x06	b1_MSB	b1 coefficient MSB	8
0x07	b1_LSB	b1 coefficient LSB	8
0x08	b2_MSB	b2 coefficient MSB	8
0x09	b2_LSB	b2 coefficient LSB	8
0x0A	c12_MSB	c12 coefficient MSB	8
0x0B	c12_LSB	c12 coefficient LSB	8
0x0C	Reserved*	—	—
0x0D	Reserved*	—	—
0x0E	Reserved*	—	—
0x0F	Reserved*	—	—
0x10	Reserved	—	—
0x11	Reserved	—	—
0x12	CONVERT	Start Pressure and Temperature Conversion	—

*These registers are set to 0x00. These are reserved, and were previously utilized as Coefficient values, c11 and c22, which were always 0x00.

For values with less than 16 bits, the lower LSBs are zero. For example, c12 is 14 bits and is stored into 2 bytes as follows:

$$\text{c12 MS byte} = \text{c12}[13:6] = [\text{c12}_{b13}, \text{c12}_{b12}, \text{c12}_{b11}, \text{c12}_{b10}, \text{c12}_{b9}, \text{c12}_{b8}, \text{c12}_{b7}, \text{c12}_{b6}]$$

$$\text{c12 LS byte} = \text{c12}[5:0] \ \& \ \text{"00"} = [\text{c12}_{b5}, \text{c12}_{b4}, \text{c12}_{b3}, \text{c12}_{b2}, \text{c12}_{b1}, \text{c12}_{b0}, 0, 0]$$

3.1 Pressure, Temperature and Coefficient Bit-Width Specifications

The table below specifies the initial coefficient bit-width specifications for the compensation algorithm and the specifications for Pressure and Temperature ADC values.

Pressure, Temperature and Compensation Coefficient Specifications						
	a0	b1	b2	c12	Padc	Tadc
Total Bits	16	16	16	14	10	10
Sign Bits	1	1	1	1	0	0
Integer Bits	12	2	1	0	10	10
Fractional Bits	3	13	14	13	0	0
dec pt zero pad	0	0	0	9	0	0

Example Binary Format Definitions:

a0 Signed, Integer Bits = 12, Fractional Bits = 3 :

b1 Signed, Integer Bits = 2, Fractional Bits = 7 :

b2 Signed, Integer Bits = 1, Fractional Bits = 14 :

c12 Signed, Integer Bits = 0, Fractional Bits = 13, dec pt zero pad = 9 :

Padc Unsigned, Integer Bits = 10 :

Tadc Unsigned, Integer Bits = 10 :

Coeff a0 = S I₁₁ I₁₀ I₉ I₈ I₇ I₆ I₅ I₄ I₃ I₂ I₁ I₀ . F₂ F₁ F₀

Coeff b1 = S I₁ I₀ . F₁₂ F₁₀ F₉ F₈ F₇ F₆ F₅ F₄ F₃ F₂ F₁ F₀

Coeff b2 = S I₀ . F₁₃ F₁₂ F₁₀ F₉ F₈ F₇ F₆ F₅ F₄ F₃ F₂ F₁ F₀

Coeff c12 = S 0 . 000 000 000 F₁₂ F₁₀ F₉ F₈ F₇ F₆ F₅ F₄ F₃ F₂ F₁ F₀

Padc U = I₉ I₈ I₇ I₆ I₅ I₄ I₃ I₂ I₁ I₀

Tadc U = I₉ I₈ I₇ I₆ I₅ I₄ I₃ I₂ I₁ I₀

NOTE: Negative coefficients are coded in 2's complement notation.

3.2 Compensation

The 10-bit compensated pressure output, Pcomp, is calculated as follows:

$$P_{comp} = a_0 + (b_1 + c_{12} \cdot T_{adc}) \cdot P_{adc} + b_2 \cdot T_{adc} \quad \text{Eqn. 1}$$

Where:

Padc is the 10-bit pressure ADC output of the MPL115A

Tadc is the 10-bit temperature ADC output of the MPL115A

a0 is the pressure offset coefficient

b1 is the pressure sensitivity coefficient

b2 is the temperature coefficient of offset (TCO)

c12 is the temperature coefficient of sensitivity (TCS)

Pcomp will produce a value of 0 with an input pressure of 50 kPa and will produce a full-scale value of 1023 with an input pressure of 115 kPa.

$$\text{Pressure (kPa)} = P_{comp} \cdot \left[\frac{115 - 50}{1023} \right] + 50 \quad \text{Eqn. 2}$$

3.3 Evaluation Sequence, Arithmetic Circuits

The following is an example of the calculation for Pcomp, the compensated pressure output. Input values are in **bold**.

$$c_{12}x_2 = \mathbf{c12} * \mathbf{Tadc}$$

$$a_1 = \mathbf{b1} + c_{12}x_2$$

$$a_1x_1 = a_1 * \mathbf{Padc}$$

$$y_1 = \mathbf{a0} + a_1x_1$$

$$a_2x_2 = \mathbf{b2} * \mathbf{Tadc}$$

$$P_{comp} = y_1 + a_2x_2$$

This can be calculated as a succession of Multiply Accumulates (MACs) operations of the form $y = a + b * x$:

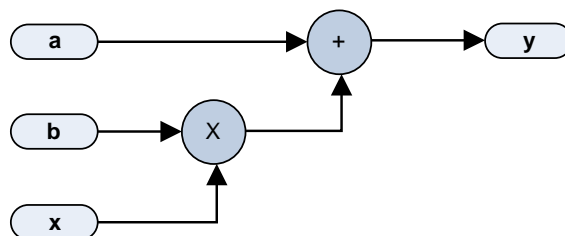

The polynomial can be evaluated (Equation 1) as a sequence of 3 MACs:

$$P_{comp} = a_0 + (b_1 + c_{12} \cdot T_{adc}) \cdot P_{adc} + b_2 \cdot T_{adc}$$

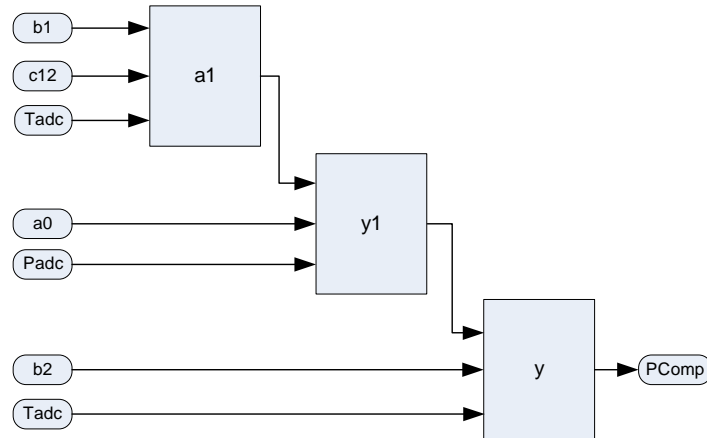

Please refer to Freescale application note AN3785 for more detailed notes on implementation.

3.4 I²C Device Read/Write Operations

All device read/write operations are memory mapped. Device actions e.g. “Start Conversions” are controlled by writing to the appropriate memory address location.

- For I²C the 7-bit Device Address (from Table 2) has a read/write toggle bit, where the least significant bit is ‘1’ for read operations or ‘0’ for write operations. The Device Address is 0xC0 for a *Write* and the Device Address is 0xC1 for a *Read*.
- The most significant bit in the Command tables below is not used and is don't care (X). In examples given it's set to ‘0’.

Refer to Sensor I²C Setup and FAQ Application Note AN4481 for more information on I²C communication between the sensor and host controller.

Table 3. I²C Write Commands

Command	Binary	HEX ⁽¹⁾
Devices Address + Write bit	1100 0000	0xC0
Start Conversions	X001 0010	0x12

X = Don't care

1 = The command byte needs to be paired with a 0x00 as part of the I²C exchange to complete the passing of Start Conversions.

The actions taken by the part in response to each command are as follows:

Table 4. I²C Write Command Description

Command	Action Taken
Start Conversions	Wake main circuits. Start clock. Allow supply stabilization time. Select pressure sensor input. Apply positive sensor excitation and perform A to D conversion. Select temperature input. Perform A to D conversion. Load the Pressure and Temperature registers with the result. Shut down main circuits and clock.

Table 5. I²C Read Command Description

Command	Binary	HEX ⁽¹⁾
Device Address + Read bit	1100 0001	0xC1
Read Pressure MSB	X000 0000	0x00
Read Pressure LSB	X000 0001	0x01
Read Temperature MSB	X000 0010	0x02
Read Temperature LSB	X000 0011	0x03
Read Coefficient data byte 1	X000 0100	0x04

X = don't care

These are MPL115A2 I²C commands to read coefficients, execute Pressure and Temperature conversions, and to read Pressure and Temperature data. The sequence of the commands for the interaction is given as an example to operate the MPL115A2.

Utilizing this gathered data, an example of the calculating the Compensated Pressure reading is given in floating point notation.

I²C Commands (simplified for communication)

- Device Address + write bit "To Write" = 0xC0
- Device Address + read bit "To Read" = 0xC1
- Command to Write "Convert Pressure and Temperature" = 0x12
- Command to Read "Pressure ADC High byte" = 0x00
- Command to Read "Pressure ADC Low byte" = 0x01
- Command to Read "Temperature ADC High byte" = 0x02
- Command to Read "Temperature ADC Low byte" = 0x03
- Command to Read "Coefficient data byte 1 High byte" = 0x04

Read Coefficients:

[0xC0], [0x04], [0xC1], [0x3E], [0xCE], [0xB3], [0xF9], [0xC5], [0x17], [0x33], [0xC8]

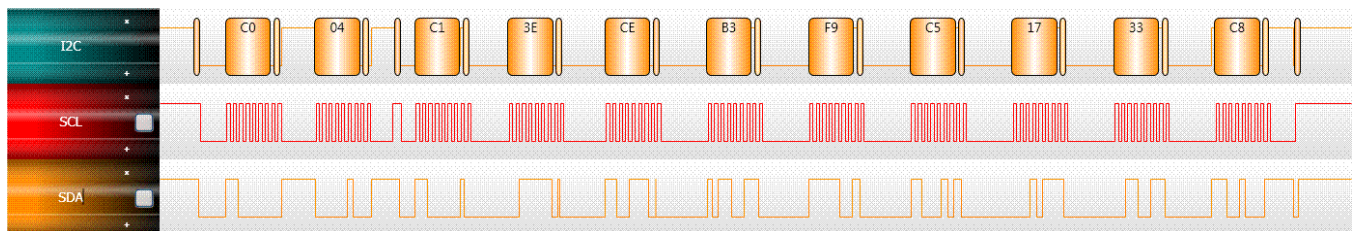

Figure 3. I²C Read Coefficient Datagram

a0 coefficient MSB = 0x3E
 a0 coefficient LSB = 0xCE a0 coefficient = 0x3ECE = 2009.75

 b1 coefficient MSB = 0xB3
 b1 coefficient LSB = 0xF9 b1 coefficient = 0xB3F9 = -2.37585

 b2 coefficient MSB = 0xC5
 b2 coefficient LSB = 0x17 b2 coefficient = 0xC517 = -0.92047

 c12 coefficient MSB = 0x33
 c12 coefficient LSB = 0xC8 c12 coefficient = 0x33C8 = 0.000790

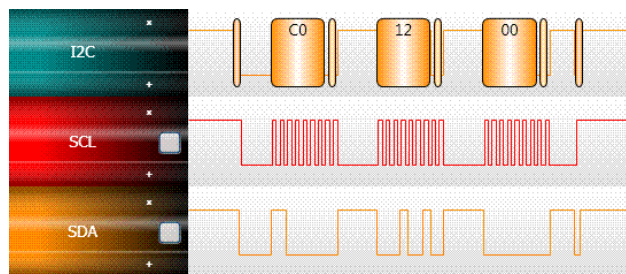

Figure 4. I²C Start Conversion Datagram
 Command to I²C Start Conversion, 0x12

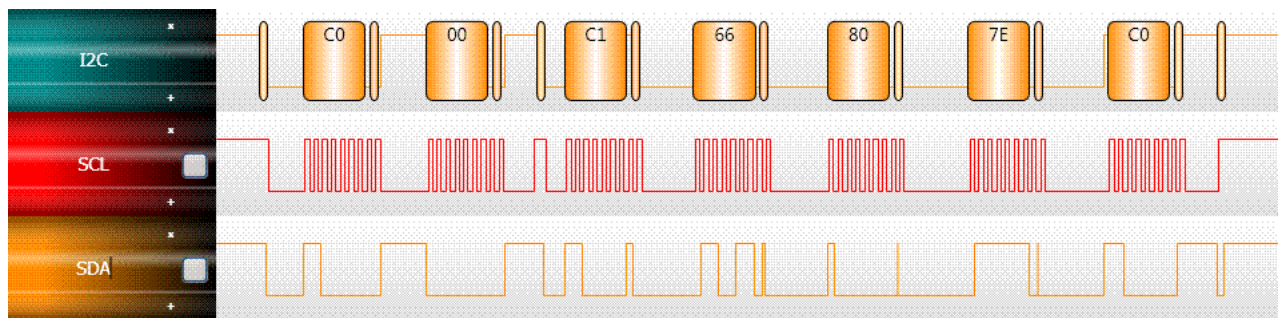

Figure 5. I²C Read Results Datagram

Pressure MSB = 0x66
 Pressure LSB = 0x80 Pressure = 0x6680 = 0110 0110 1100 0000
 = 410 ADC counts

 Temperature MSB = 0x7E
 Temperature LSB = 0xC0 Temperature = 0x7EC0 = 0111 1110 1100 0000
 = 507 ADC counts

3.5 Example of Pressure Compensated Calculation in Floating-point Notation

a0 coefficient = 2009.75
b1 coefficient = -2.37585
b2 coefficient = -0.92047
c12 coefficient = 0.000790

Pressure = 410 ADC counts
Temperature = 507 ADC counts

Pressure Compensation:

$$P_{\text{comp}} = a_0 + (b_1 + c_{12} \cdot T_{\text{adc}}) \cdot P_{\text{adc}} + b_2 \cdot T_{\text{adc}}$$

Using the evaluation sequence shown in Section 3.3:

$$\begin{aligned}c_{12}x_2 &= c_{12} \cdot T_{\text{adc}} = 0.000790 \cdot 507 &&= 0.40053 \\a_1 &= b_1 + c_{12}x_2 = -2.37585 + 0.40053 &&= -1.97532 \\a_1x_1 &= a_1 \cdot P_{\text{adc}} = -1.97532 \cdot 410 &&= -809.8812 \\y_1 &= a_0 + a_1x_1 = 2009.75 + (-809.8812) &&= 1199.8688 \\a_2x_2 &= b_2 \cdot T_{\text{adc}} = -0.92047 \cdot 507 &&= -466.67829 \\P_{\text{Comp}} &= y_1 + a_2x_2 = 1199.8688 + (-466.67829) &&= 733.19051\end{aligned}$$

$$\begin{aligned}\text{Pressure (kPa)} &= P_{\text{comp}} \cdot \left[\frac{115 - 50}{1023} \right] + 50 \\&= 733.19 \cdot \left[\frac{115 - 50}{1023} \right] + 50 \\&= 96.59 \text{ kPa}\end{aligned}$$

4 Solder Recommendations

1. Use SAC solder alloy (i.e., Sn-Ag-Cu) with a melting point of about 217°C. It is recommended to use SAC305 (i.e., Sn-3.0 wt.% Ag-0.5 wt.% Cu).
2. Reflow
 - Ramp up rate: 2 to 3°C/s.
 - Preheat flat (soak): 110 to 130s.
 - Reflow peak temperature: 250°C to 260°C (depends on exact SAC alloy composition).
 - Time above 217°C: 40 to 90s (depends on board type, thermal mass of the board/quantities in the reflow).
 - Ramp down: 5 to 6°C/s.
 - Using an inert reflow environment (with O₂ level about 5 to 15 ppm).

NOTE: The stress level and signal offset of the device also depends on the board type, board core material, board thickness and metal finishing of the board.

Please refer to Freescale application note AN3150, Soldering Recommendations for Pressure Sensor Devices for any additional information.

5 Handling Recommendations

It is recommended to handle the MPL115A pressure sensor with a vacuum pick and place tool. Sharp objects utilized to move the MPL115A pressure sensor increase the possibility of damage via a foreign object/tool into the small exposed port.

The sensor die is sensitive to light exposure. Direct light exposure through the port hole can lead to varied accuracy of pressure measurement. Avoid such exposure to the port during normal operation.

Please note that the Pin 1 designator is on the bottom of the package. Do not use the port as an orientation reference in production.

6 Soldering/Landing Pad Information

The LGA package is compliant with the RoHS standard. It is recommended to use a no-clean solder paste to reduce cleaning exposure to high pressure and chemical agents that can damage or reduce life span of the Pressure sensing element.

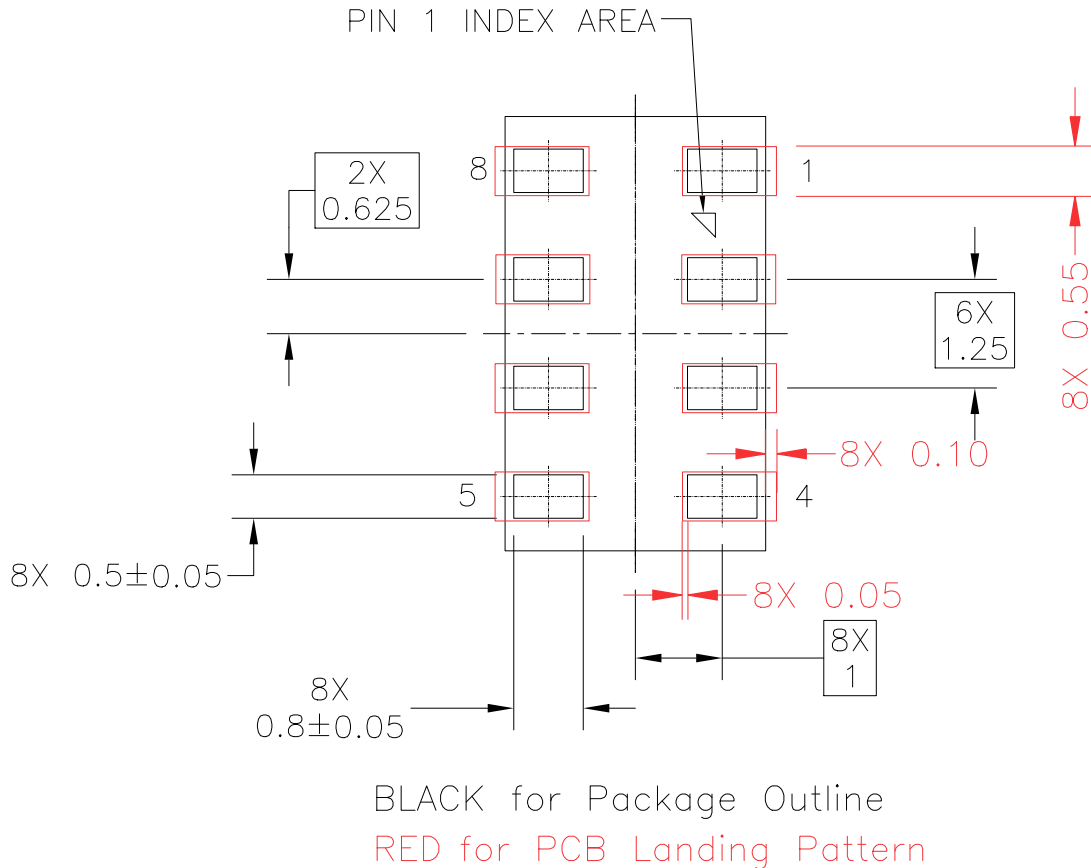

Figure 6. MPL115A2 Recommended PCB Landing Pattern

7 Tape and Reel Specifications

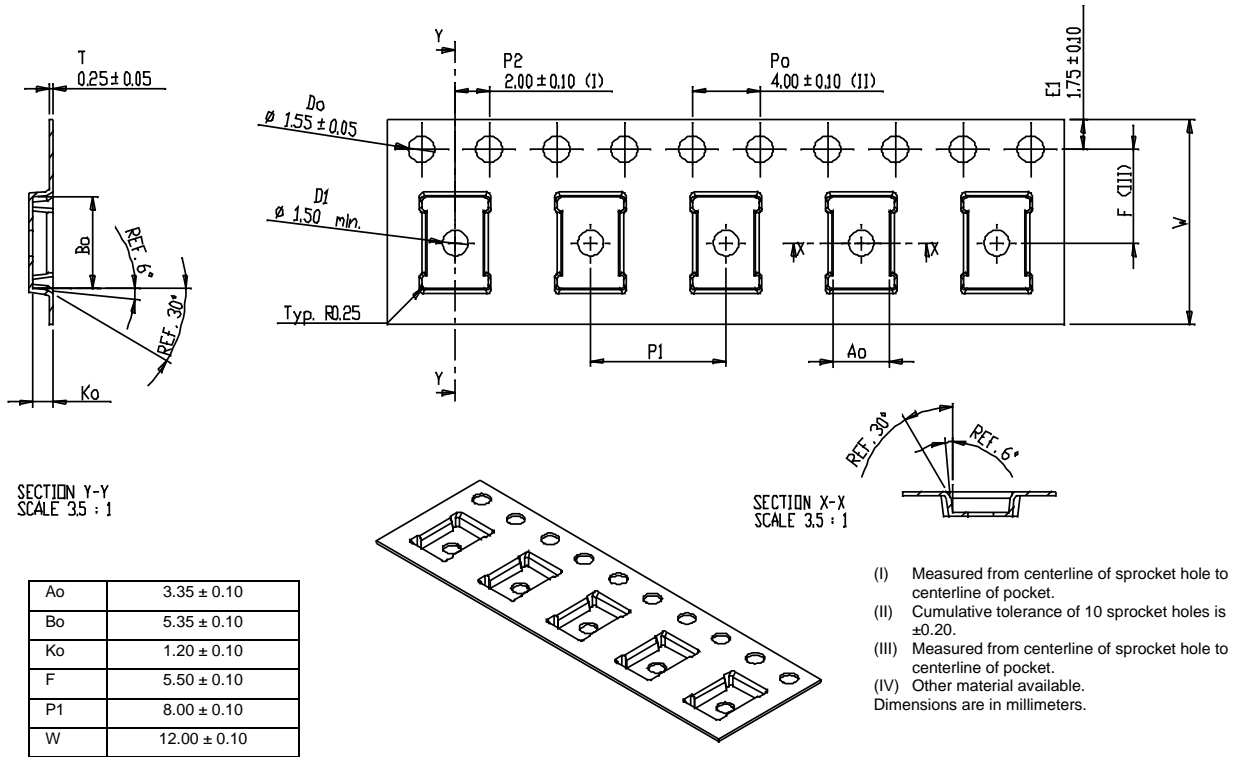

Figure 7. LGA (3 by 5) Embossed Carrier Tape Dimensions

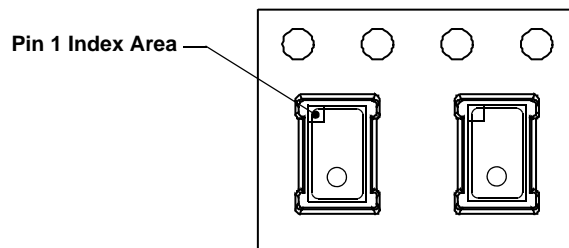
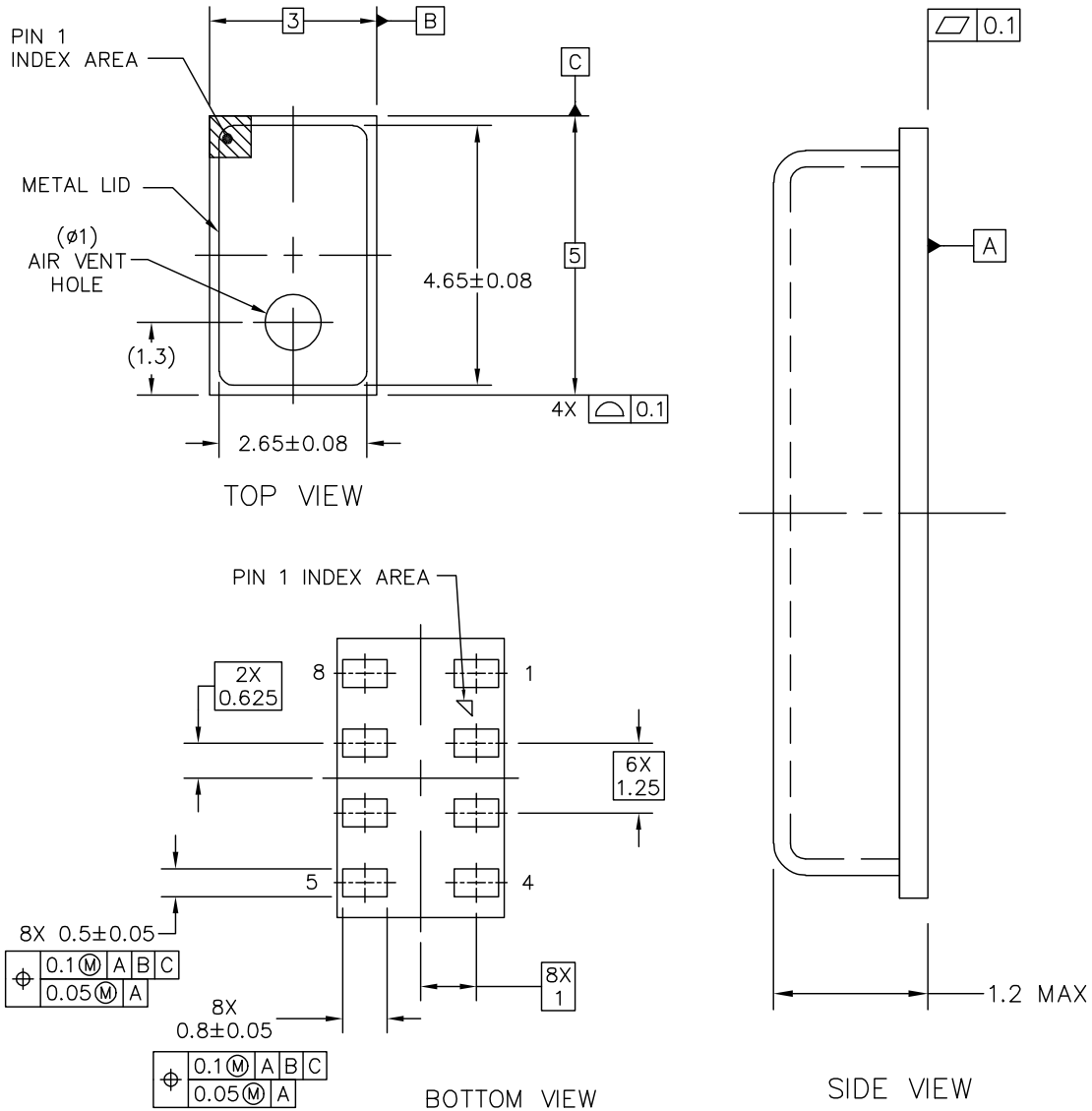

Figure 8. Device Orientation in Chip Carrier

PACKAGE DIMENSIONS



NOTES:

1. ALL DIMENSIONS IN MILLIMETERS.
2. DIMENSIONING AND TOLERANCING PER ASME Y14.5M-1994

© FREESCALE SEMICONDUCTOR, INC. ALL RIGHTS RESERVED.	MECHANICAL OUTLINE	PRINT VERSION NOT TO SCALE
TITLE: LGA 8 I/O, 3 X 5 X 1.25 PITCH, SENSOR 1.2MAX MM PKG		DOCUMENT NO: 98ASA10829D CASE NUMBER: 2015-02 STANDARD: NON-JEDEC
		REV: A 10 MAR 2010

**CASE 2015-02
ISSUE A
LGA PACKAGE**

Related Documentation

The MPL115A2 device features and operations are described in a variety of reference manuals, user guides, and application notes. To find the most-current versions of these documents:

1. Go to the Freescale homepage at:
<http://www.freescale.com/>
2. In the Keyword search box at the top of the page, enter the device number MPL115A2.
3. In the Refine Your Result pane on the left, click on the Documentation link.

Table 6. Revision History

Revision number	Revision date	Description of changes
8	06/2012	<ul style="list-style-type: none">• Updated graphic on page 1, Section 2.2 Operating Characteristics: Ref 7: Conversion Time: changed Typ from 3.0 to 1.6, Section 3.0 Overview of Functions/Operation: Reading Coefficient Data deleted statement that reading of coefficients may be executed only once, Table 2: added Size (bits) column in table, added new Section 3.4 I²C Device Read/Write Operations
		<ul style="list-style-type: none">•
		<ul style="list-style-type: none">•

Information in this document is provided solely to enable system and software implementers to use Freescale Semiconductor products. There are no express or implied copyright licenses granted hereunder to design or fabricate any integrated circuits or integrated circuits based on the information in this document.

Freescale Semiconductor reserves the right to make changes without further notice to any products herein. Freescale Semiconductor makes no warranty, representation or guarantee regarding the suitability of its products for any particular purpose, nor does Freescale Semiconductor assume any liability arising out of the application or use of any product or circuit, and specifically disclaims any and all liability, including without limitation consequential or incidental damages. "Typical" parameters that may be provided in Freescale Semiconductor data sheets and/or specifications can and do vary in different applications and actual performance may vary over time. All operating parameters, including "Typicals", must be validated for each customer application by customer's technical experts. Freescale Semiconductor does not convey any license under its patent rights nor the rights of others. Freescale Semiconductor products are not designed, intended, or authorized for use as components in systems intended for surgical implant into the body, or other applications intended to support or sustain life, or for any other application in which the failure of the Freescale Semiconductor product could create a situation where personal injury or death may occur. Should Buyer purchase or use Freescale Semiconductor products for any such unintended or unauthorized application, Buyer shall indemnify and hold Freescale Semiconductor and its officers, employees, subsidiaries, affiliates, and distributors harmless against all claims, costs, damages, and expenses, and reasonable attorney fees arising out of, directly or indirectly, any claim of personal injury or death associated with such unintended or unauthorized use, even if such claim alleges that Freescale Semiconductor was negligent regarding the design or manufacture of the part.

Freescale and the Freescale logo are trademarks of Freescale Semiconductor, Inc., Reg. U.S. Pat. & Tm. Off. All other product or service names are the property of their respective owners.

© 2012 Freescale Semiconductor, Inc. All rights reserved.

Компания «Life Electronics» занимается поставками электронных компонентов импортного и отечественного производства от производителей и со складов крупных дистрибьюторов Европы, Америки и Азии.

С конца 2013 года компания активно расширяет линейку поставок компонентов по направлению коаксиальный кабель, кварцевые генераторы и конденсаторы (керамические, пленочные, электролитические), за счёт заключения дистрибьюторских договоров

Мы предлагаем:

- Конкурентоспособные цены и скидки постоянным клиентам.
- Специальные условия для постоянных клиентов.
- Подбор аналогов.
- Поставку компонентов в любых объемах, удовлетворяющих вашим потребностям.
- Приемлемые сроки поставки, возможна ускоренная поставка.
- Доставку товара в любую точку России и стран СНГ.
- Комплексную поставку.
- Работу по проектам и поставку образцов.
- Формирование склада под заказчика.
- Сертификаты соответствия на поставляемую продукцию (по желанию клиента).
- Тестирование поставляемой продукции.
- Поставку компонентов, требующих военную и космическую приемку.
- Входной контроль качества.
- Наличие сертификата ISO.

В составе нашей компании организован Конструкторский отдел, призванный помогать разработчикам, и инженерам.

Конструкторский отдел помогает осуществить:

- Регистрацию проекта у производителя компонентов.
- Техническую поддержку проекта.
- Защиту от снятия компонента с производства.
- Оценку стоимости проекта по компонентам.
- Изготовление тестовой платы монтаж и пусконаладочные работы.



Тел: +7 (812) 336 43 04 (многоканальный)

Email: org@lifeelectronics.ru