

SECTION Z-Z

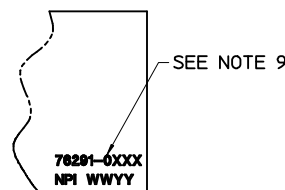
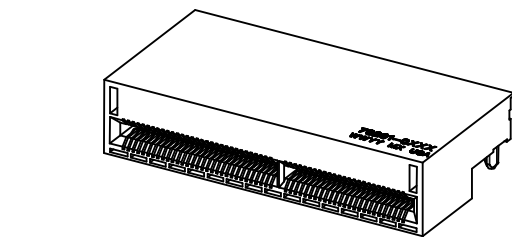
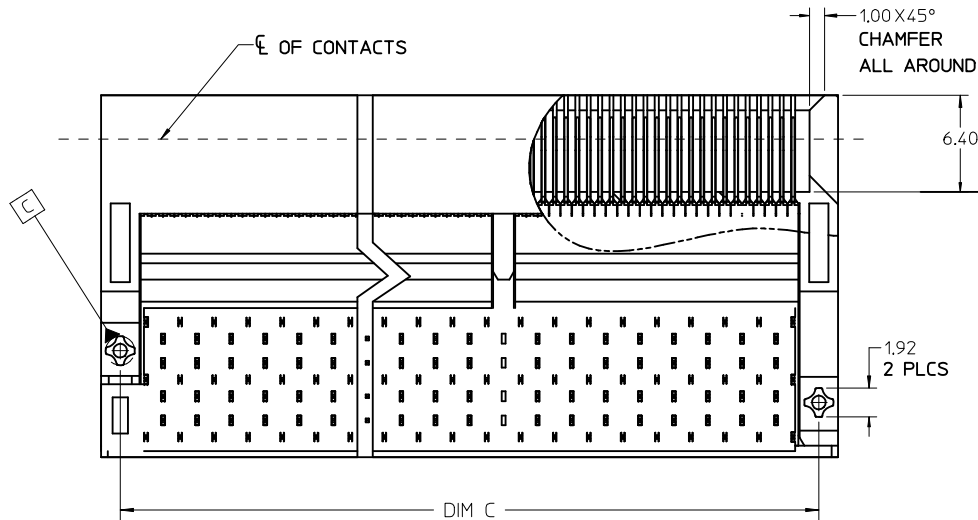

TOP VIEW

NOTES:

1. MATERIAL -
CONNECTOR HOUSING - GLASS FILLED LCP, 94V-0, BLACK
OVERMOLDING ON TERMINALS: GLASS FILLED LCP, 94V-0, BLACK
TERMINALS: COPPER ALLOY, SPRING TEMPER
2. TERMINAL FINISH:
CONTACT AREA: .754m HARD GOLD OVER 3.84m MIN NICKEL.
COMPLIANT AREA: .75-1.504m TIN OVER .754m - 1.504m NICKEL.
3. FOR CIRCUIT SIZES GREATER THAN 170, A CENTER ALIGNMENT KEY WILL BE USED.
4. REFER TO PS-76291-001 PRODUCT SPEC FOR ALL ELECTRICAL, MECHANICAL, AND ENVIRONMENTAL SPECIFICATIONS.
5. REFER TO PK-76291-001 FOR ALL PACKAGING SPECIFICATIONS.
6. REFER TO AS-76291-001 FOR BOARD APPLICATION INFORMATION.
7. MODULE BOARD CONTACT PAD PLATING TO BE .764m MIN HARD GOLD OVER 2.544m MIN NICKEL
8. MODULE BOARD CONTACT PAD SURFACE ROUGHNESS NOT TO EXCEED Ra 0.24m.
9. PART TO BE LASER MARKED WITH PART NUMBER, WHERE XXX IS THE CIRCUIT SIZE OR POWER WAFER OPTION, MANUFACTURING FACILITY, AND DATE CODE IN THE FORMATE OF THE WEEK AND LAST 2 DIGITS OF THE YEAR: WWYY

LEADFREE CONVERTER. EC NO: UCP2013-2374 DRW:MP0FF 2012/11/15 CHK:MMWLF 2012/11/15 APPR:SMILLER 2013/01/04 REV:	QUALITY SYMBOLS 	GENERAL TOLERANCES (UNLESS SPECIFIED)		DIMENSION STYLE MM ONLY	SCALE 4:1	DESIGN UNITS METRIC	THIRD ANGLE PROJECTION
		4 PLACES ± --- ± --- 3 PLACES ± --- ± --- 2 PLACES ± 0.13 ± --- 1 PLACE ± 0.25 ± --- 0 PLACE ± --- ± ---	mm INCH	DRAWN BY DATE CHECKED BY DATE APPROVED BY DATE MBANAK I S 2010/11/17	TITLE COPLANAR CONNECTOR GENERAL SALES DRAWING	MATERIAL NO. SEE TABLE	DOCUMENT NO. SD-76291-001
DRAFT WHERE APPLICABLE MUST REMAIN WITHIN DIMENSIONS		ANGULAR ±1/2°		THIS DRAWING CONTAINS INFORMATION THAT IS PROPRIETARY TO MOLEX INCORPORATED AND SHOULD NOT BE USED WITHOUT WRITTEN PERMISSION			

PART NUMBER									
TIN	TIN PREVIOUSLY TIN/LEAD	STATUS	CKTS	DIM A	DIM B	DIM C	DIM D	PW POS	DIM E
762910008	762911008	NOT TOOLED	8	8.19	4.40	5.65	4.25	-	10.84
762910014	762911014	NOT TOOLED	14	10.44	6.65	7.90	6.50	-	10.84
762910020	762911020	NOT TOOLED	20	12.69	8.90	10.15	8.75	-	10.84
762910026	762911026	NOT TOOLED	26	14.94	11.15	12.40	11.00	-	10.84
762910032	762911032	NOT TOOLED	32	17.19	13.40	14.65	13.25	-	10.84
762910038	762911038		38	19.44	15.60	16.90	15.50	-	10.84
762910044	762911044	NOT TOOLED	44	21.69	17.90	19.15	17.75	-	10.84
762910050	762911050	NOT TOOLED	50	23.94	20.15	21.40	20.00	-	10.84
762910056	762911056	NOT TOOLED	56	26.19	22.40	23.65	22.25	-	10.84
762910062	762911062	NOT TOOLED	62	28.44	24.65	25.90	24.50	-	10.84
762910068	762911068		68	30.69	26.90	28.15	26.75	-	10.84
762910074	762911074	NOT TOOLED	74	32.94	29.15	30.40	29.00	-	10.84
762910080	762911080	NOT TOOLED	80	35.19	31.40	32.65	31.25	-	10.84
762910086	762911086	NOT TOOLED	86	37.44	33.65	34.90	33.50	-	10.84
762910092	762911092	NOT TOOLED	92	39.69	35.90	37.15	35.75	-	10.84
762910098	762911098	NOT TOOLED	98	41.94	38.15	39.40	38.00	-	10.84
762910104	762911104	NOT TOOLED	104	44.19	40.40	41.65	40.25	-	10.84
762910110	762911110	NOT TOOLED	110	46.44	42.65	43.90	42.50	-	10.84
762910116	762911116	NOT TOOLED	116	48.69	44.90	46.15	44.75	-	10.84
762910122	762911122	NOT TOOLED	122	50.94	47.15	48.40	47.00	-	10.84
762910128	762911128	NOT TOOLED	128	53.19	49.40	50.65	49.25	-	10.84
762910134	762911134	NOT TOOLED	134	55.44	51.65	52.90	51.50	-	10.84
762910140	762911140		140	57.69	53.90	55.15	53.75	-	10.84
762910146	762911146	NOT TOOLED	146	59.94	56.15	57.40	56.00	-	10.84
762910152	762911152	NOT TOOLED	152	62.19	58.40	59.65	58.25	-	10.84
762910158	762911158	NOT TOOLED	158	64.44	60.65	61.90	60.50	-	10.84
762910164	762911164	NOT TOOLED	164	66.69	62.90	64.15	62.75	-	10.84
762910170	762911170		170	68.94	65.15	66.40	65.00	-	10.84
762910171	762911171		170	68.94	65.15	66.40	65.00	2	10.84
762910172	762911172		170	68.94	65.15	66.40	65.00	28	10.84
762910178	762911078	NOT TOOLED	178	73.44	69.65	70.90	69.50	-	10.84
762910184	762911184	NOT TOOLED	184	75.69	71.90	73.15	71.75	-	10.84
762910190	762911190	NOT TOOLED	190	77.94	74.15	75.40	74.00	-	10.84
762910196	762911196	NOT TOOLED	196	80.19	76.40	77.65	76.25	-	10.84
762910202	762911202	NOT TOOLED	202	82.44	78.65	79.90	78.50	-	10.84
762910208	762911208	NOT TOOLED	208	84.69	80.90	82.15	80.75	-	10.84
762910214	762911214	NOT TOOLED	214	86.94	83.15	84.40	83.00	-	10.84
762910220	762911220	NOT TOOLED	220	89.19	85.40	86.65	85.25	-	10.84
762910226	762911226		226	91.44	87.65	88.90	87.50	-	10.84
762912226	762913226		226	91.44	87.65	88.90	87.50	-	9.92
762910232	762911232	NOT TOOLED	232	93.69	89.90	91.15	89.75	-	10.84
762910238	762911238	NOT TOOLED	238	95.94	92.15	93.40	92.00	-	10.84
762910244	762911244	NOT TOOLED	244	98.19	94.40	95.65	94.25	-	10.84
762910250	762911250		250	100.44	96.65	97.90	96.50	-	10.84

POSITIONS FOR SINGULATED GROUND WAFERS

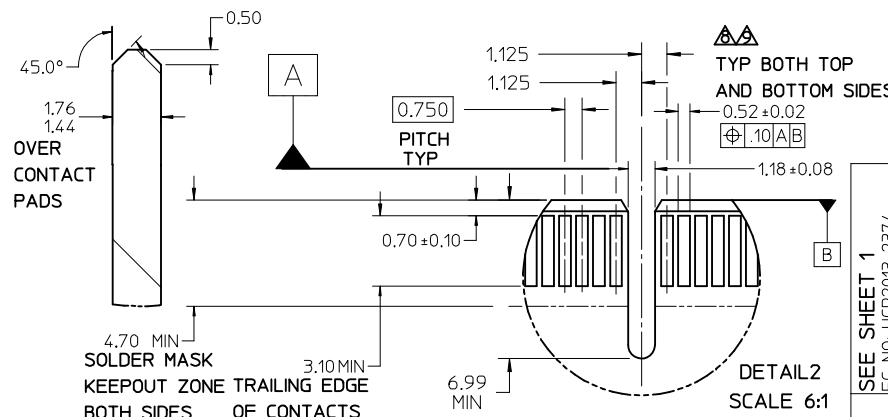
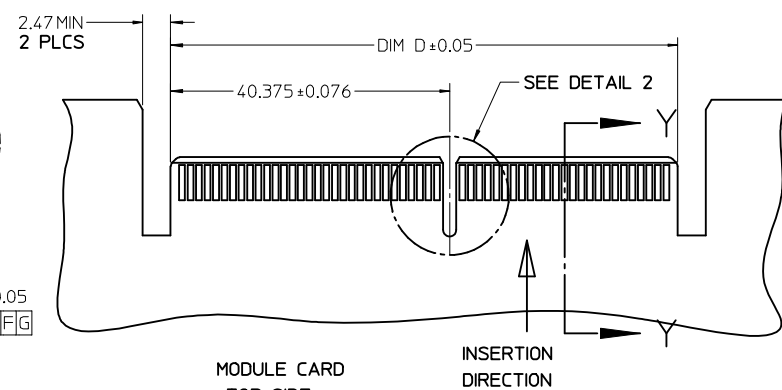
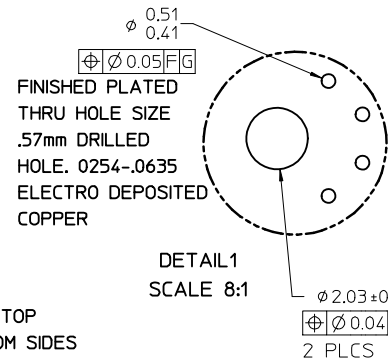
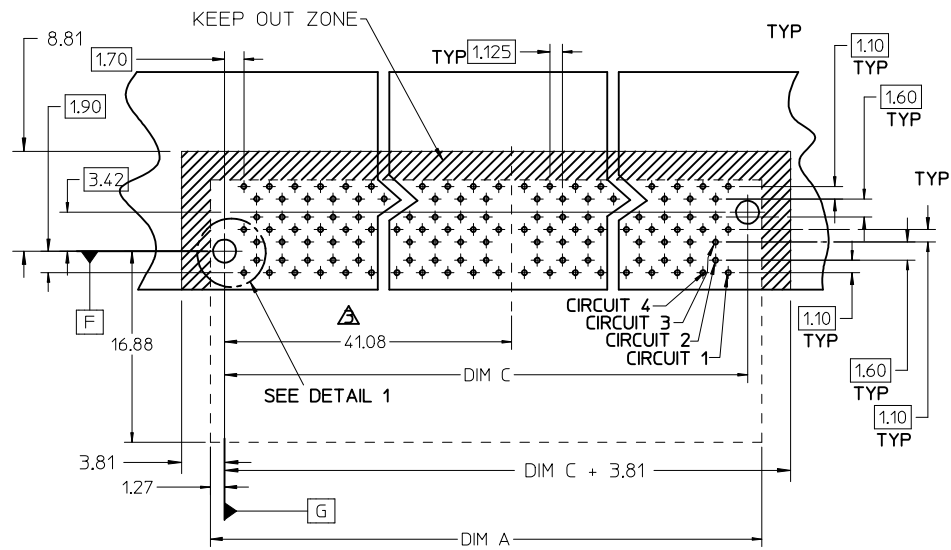
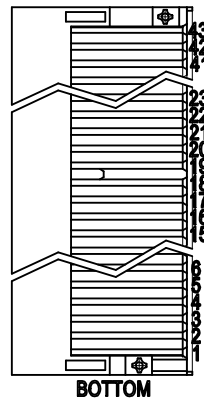

SEE SHEET 1 EC NO: UCP2013-2374 DRW:MP/0FF 2012/11/15 CHKD:HW/0FE 2012/11/15 APPR:SM/0LLER 2013/01/04	QUALITY SYMBOLS	GENERAL TOLERANCES (UNLESS SPECIFIED)	DIMENSION STYLE	SCALE	DESIGN UNITS	THIRD ANGLE PROJECTION
	▽=0	mm INCH	MM ONLY	4:1	METRIC	
	▽=0	4 PLACES ± --- ± ---	DRAWN BY DATE	TITLE	COPLANAR CONNECTOR GENERAL SALES DRAWING	
	▽=0	3 PLACES ± --- ± ---	CHECKED BY DATE	molex SD-76291-001		
	2 PLACES ± 0.13 ± ---	APPROVED BY DATE	SHEET NO. 2 OF 4			
	1 PLACE ± 0.25 ± ---	MBANAKIS 2010/11/17	DOCUMENT NO.			
	0 PLACE ± --- ± ---	SEE TABLE	THIS DRAWING CONTAINS INFORMATION THAT IS PROPRIETARY TO MOLEX INCORPORATED AND SHOULD NOT BE USED WITHOUT WRITTEN PERMISSION			

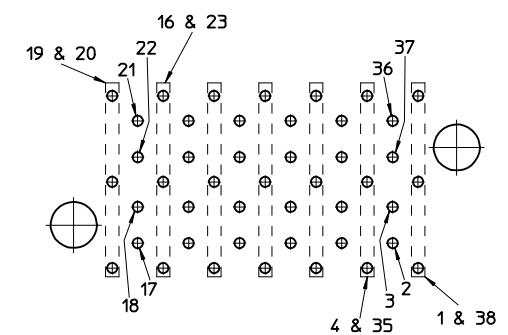

76291-0038

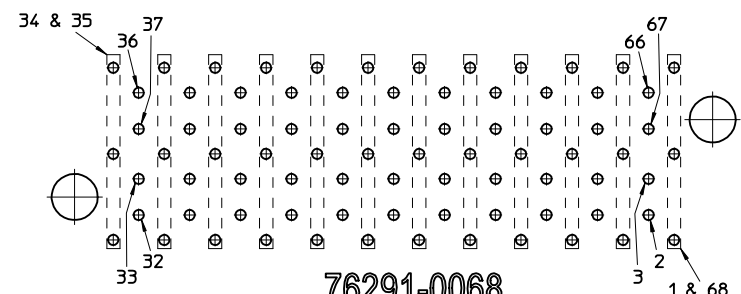

76291-0068

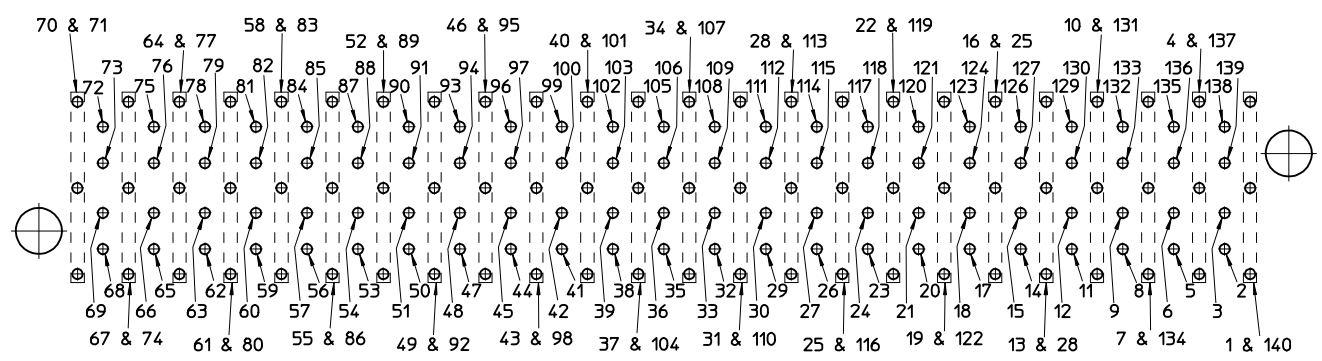
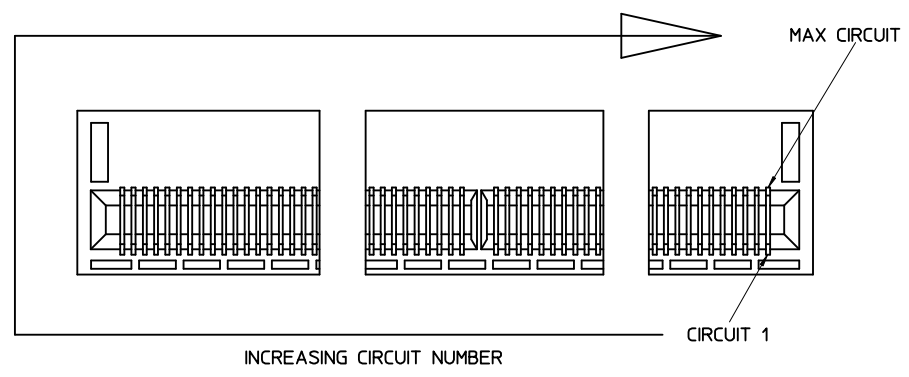

76291-0140

NOTES ON CIRCUIT DESIGNATIONS

1. CIRCUIT 1 STARTS AT LOWER RIGHT HAND CORNER AND INCREASES TO THE LEFT ACROSS THE BOTTOM AND INCREASES TO THE RIGHT ACROSS THE TOP.
2. THERE IS NOT A 1:1 CORRESPONDENCE BETWEEN THE CIRCUIT NUMBER AND THE TAIL HOLE LOCATIONS. EACH GROUND HAS TWO CONTACTS AND THREE TAILS. THE BOXES AROUND THE THREE VERTICAL HOLES INDICATE THE UPPER AND LOWER GROUND CONTACTS SHARE THE THREE TAIL HOLE LOCATIONS.

SEE SHEET 1 EC NO: UCP2013-2374 DRWN:POFF 2012/11/15 CHKD:MOLFE 2012/11/15 APPR:SMILLER 2013/01/04 REV:	QUALITY SYMBOLS ▽=0 ▽=0 ▽=0	GENERAL TOLERANCES (UNLESS SPECIFIED) mm INCH 4 PLACES ± --- ± --- 3 PLACES ± --- ± --- 2 PLACES ± 0.13 ± --- 1 PLACE ± 0.25 ± --- 0 PLACE ± --- ± --- ANGULAR ±1/2°	DIMENSION STYLE MM ONLY DRAWN BY DATE CHECKED BY DATE APPROVED BY DATE MBANAKIS 2010/11/17 MATERIAL NO.	SCALE 4:1 DESIGN UNITS METRIC THIRD ANGLE PROJECTION	COPLANAR CONNECTOR GENERAL SALES DRAWING molex DOCUMENT NO. SD-76291-001 SHEET NO. 3 OF 4
	DRAFT WHERE APPLICABLE MUST REMAIN WITHIN DIMENSIONS		SIZE C	THIS DRAWING CONTAINS INFORMATION THAT IS PROPRIETARY TO MOLEX INCORPORATED AND SHOULD NOT BE USED WITHOUT WRITTEN PERMISSION	

13 12 11 10 9 8 7 6 5 4 3 2 1

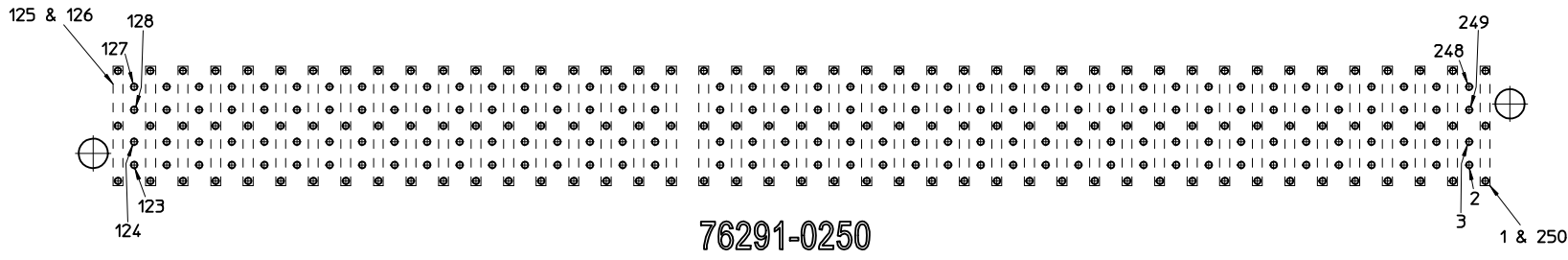
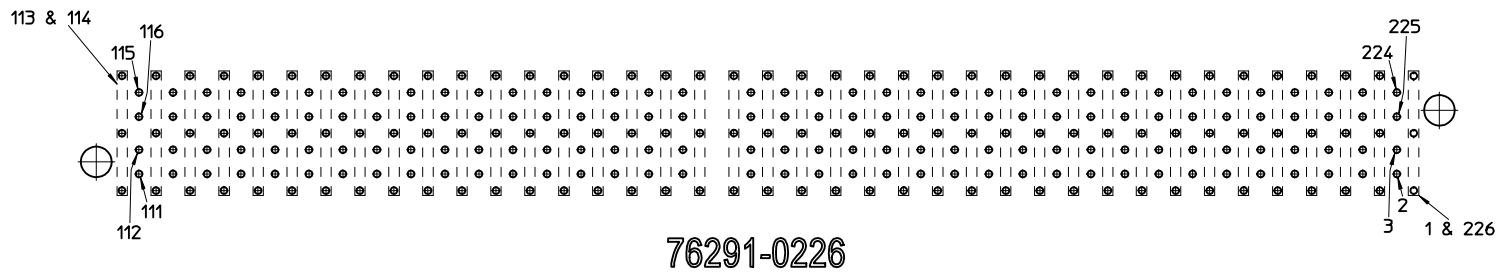
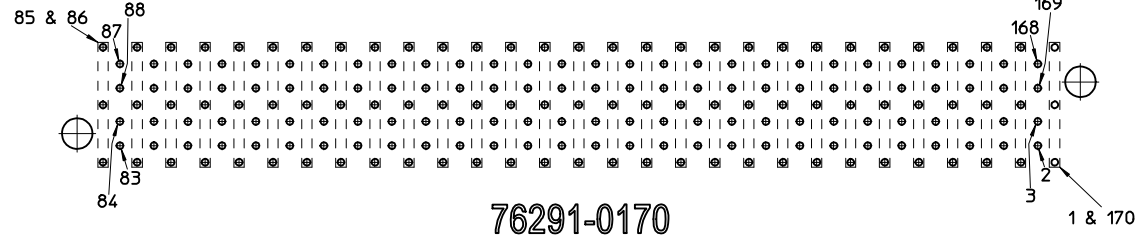

SEE SHEET 1 EC NO: UCP2013-2374 DRWIN:POFF 2012/11/15 CHKD:MWLF 2012/11/15 APPR:SMILLER 2013/01/04	DESCRIPTION QUALITY SYMBOLS $\nabla=0$ $\nabla=0$ $\nabla=0$	GENERAL TOLERANCES (UNLESS SPECIFIED)		DIMENSION STYLE MM ONLY		SCALE 4:1	DESIGN UNITS METRIC	\odot \square THIRD ANGLE PROJECTION																	
		<table border="1"> <thead> <tr> <th></th> <th>mm</th> <th>INCH</th> </tr> </thead> <tbody> <tr> <td>4 PLACES</td> <td>\pm---</td> <td>\pm---</td> </tr> <tr> <td>3 PLACES</td> <td>\pm---</td> <td>\pm---</td> </tr> <tr> <td>2 PLACES</td> <td>± 0.13</td> <td>\pm---</td> </tr> <tr> <td>1 PLACE</td> <td>± 0.25</td> <td>\pm---</td> </tr> <tr> <td>0 PLACE</td> <td>\pm---</td> <td>\pm---</td> </tr> </tbody> </table>			mm	INCH	4 PLACES	\pm ---	\pm ---	3 PLACES	\pm ---	\pm ---	2 PLACES	± 0.13	\pm ---	1 PLACE	± 0.25	\pm ---	0 PLACE	\pm ---	\pm ---	DRAWN BY _____ DATE _____ CHECKED BY _____ DATE _____		TITLE COPLANAR CONNECTOR GENERAL SALES DRAWING	
			mm	INCH																					
		4 PLACES	\pm ---	\pm ---																					
3 PLACES	\pm ---	\pm ---																							
2 PLACES	± 0.13	\pm ---																							
1 PLACE	± 0.25	\pm ---																							
0 PLACE	\pm ---	\pm ---																							
ANGULAR $\pm 1/2^\circ$		APPROVED BY _____ DATE _____ MBANAKIS 2010/11/17		DOCUMENT NO. SD-76291-001		SHEET NO. 4 OF 4																			
DRAFT WHERE APPLICABLE MUST REMAIN WITHIN DIMENSIONS		MATERIAL NO. SEE TABLE		THIS DRAWING CONTAINS INFORMATION THAT IS PROPRIETARY TO MOLEX INCORPORATED AND SHOULD NOT BE USED WITHOUT WRITTEN PERMISSION																					

Компания «Life Electronics» занимается поставками электронных компонентов импортного и отечественного производства от производителей и со складов крупных дистрибьюторов Европы, Америки и Азии.

С конца 2013 года компания активно расширяет линейку поставок компонентов по направлению коаксиальный кабель, кварцевые генераторы и конденсаторы (керамические, пленочные, электролитические), за счёт заключения дистрибьюторских договоров

Мы предлагаем:

- Конкурентоспособные цены и скидки постоянным клиентам.
- Специальные условия для постоянных клиентов.
- Подбор аналогов.
- Поставку компонентов в любых объемах, удовлетворяющих вашим потребностям.
- Приемлемые сроки поставки, возможна ускоренная поставка.
- Доставку товара в любую точку России и стран СНГ.
- Комплексную поставку.
- Работу по проектам и поставку образцов.
- Формирование склада под заказчика.
- Сертификаты соответствия на поставляемую продукцию (по желанию клиента).
- Тестирование поставляемой продукции.
- Поставку компонентов, требующих военную и космическую приемку.
- Входной контроль качества.
- Наличие сертификата ISO.

В составе нашей компании организован Конструкторский отдел, призванный помогать разработчикам, и инженерам.

Конструкторский отдел помогает осуществить:

- Регистрацию проекта у производителя компонентов.
- Техническую поддержку проекта.
- Защиту от снятия компонента с производства.
- Оценку стоимости проекта по компонентам.
- Изготовление тестовой платы монтаж и пусконаладочные работы.



Тел: +7 (812) 336 43 04 (многоканальный)

Email: org@lifeelectronics.ru