

Software Embedded Wireless LAN Module 802.11b/g/n WYSACVLXY-XX & WBSACVLXY-1 Overview

Version 1.0

March 25th, 2016

WYSACVLXY-XX: Software Embedded 802.11b/g/n Module

Features

- SMD type module. with trace ANT
- IEEE802.11b/g/n conformity.
- Channel Number : 1 to 11 channel (11bgn)
- Interface : UART (baud rate: 9600~2000000, default 115200)
- Built-in Application Processor, WLAN front end, Flash Memory, Xtal, Power circuits
- Security: WPA-2 using AES/CCMP along with legacy security features
- Advanced Wi-Fi features: 802.11n, Micro-AP mode, client mode, WPS
- Software: HTTP client, HTTPs client, WPS, IEEE power save/Deep sleep, Firmware update
- Outline: 21.4 x 14.0 x 2.4max mm
- Package: Metal case package
- Japan, FCC and IC qualified
- CE conducted test report available
- RoHS Conformity

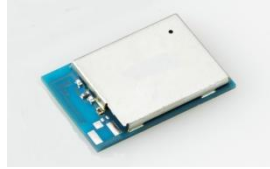

Block Diagram

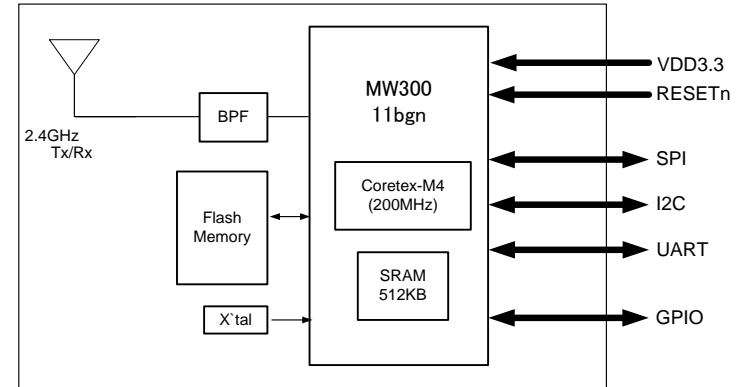

General Electrical Specification

Parameter	Description	Min.	Typ.	Max.	Units
Frequency Range	11b/ g/ n	2412		2462	MHz
Operation Voltage	VBAT	3.0	3.3	3.6	V
	VIO	3.0	3.3	3.6	V
TX Output Power(11b/g/n)	11b/11g/11n		15 / 9 / 9		dBm
RX Sensitivity (11b/g/n)	11b/11g/11n		-86 / -71 / -68		dBm
TX Power Consumption	Burst Mode 11b		165		mA
RX Power Consumption	Mode 11n-HT20		82		mA
Power Consumption	Sleep Mode		0.6		mA
Operating Temperature		-30		85	deg-C

Outline

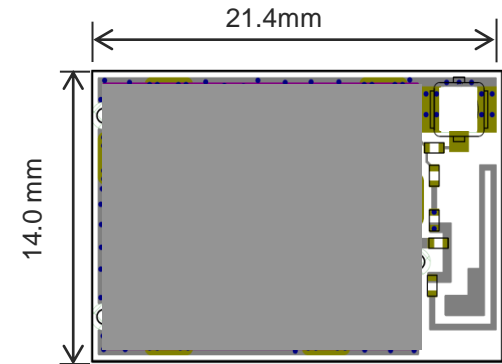

WBSACVLXY-1: Wireless LAN Module Evaluation Kit

To Evaluate WLAN Module WYSACVLXY-XX
You Will Need WBSACVLXY-1

WBSACVLXY-1 is the evaluation kit for WLAN Module **WYSACVLXY-XX**. This kit has everything you need to evaluate the performance of this module.

1 WBSACVLXY-1



WBSACVLXY-1 Kit includes:

No.	Item	Description	Qty
1	WBSACVLXY-1	Evaluation Board for WLAN module WYSACVLXY-XX with mini USB interface	1
2	Document access information	A card described information to download technical documents.	1

Supplemental Product Information

What will be provided if the Evaluation Board is purchased

- Software Specification: Command Reference document

Attention: WYSACVLXY-XX (not WBSACVLXY-1) provided by web distributor is not bundled any above document. To get it, you need to purchase WBSACVLXY-1 (Evaluation Board).

Anyone can access other documents at the following site:

English: <http://www.yuden.co.jp/ut/product/category/module/WYSACVLXY-XX.html>

Japanese: <http://www.yuden.co.jp/jp/product/category/module/WYSACVLXY-XX.html>

Example of hardware configuration for WBSACVLXY-1

- In case of connect with PC

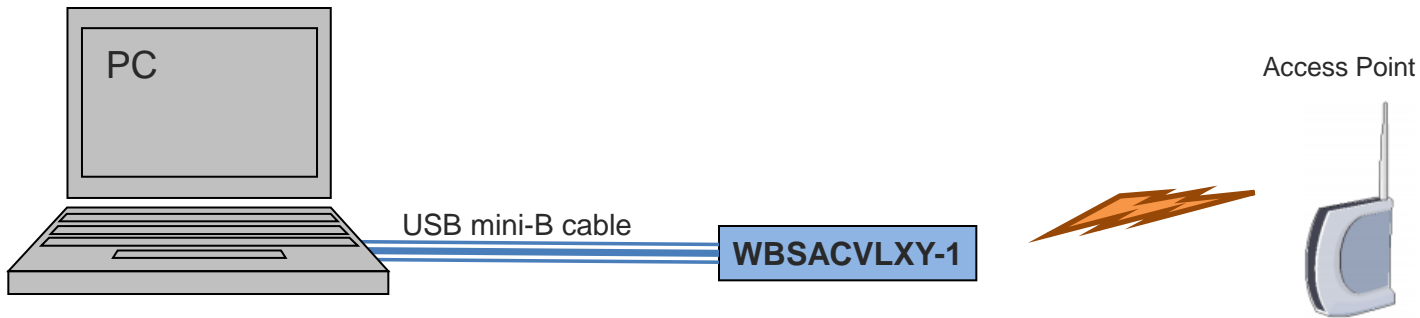

- In case of connect with Arduino

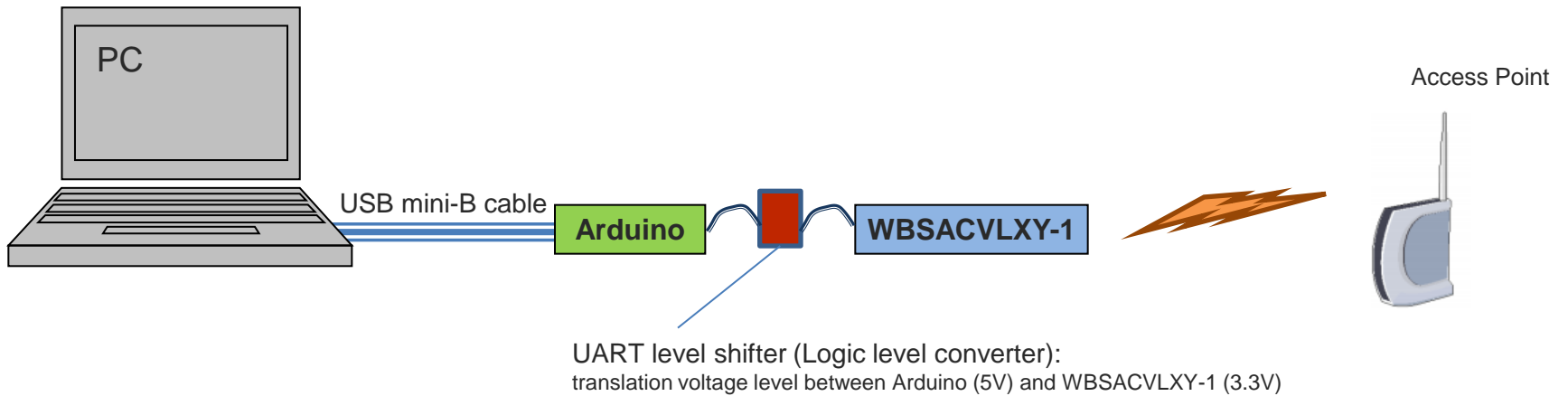

Attention: USB mini-B cable is not bundled in WBSACVLXY-1

Software Structure

WYSACVLXY-XX is a software embedded wireless LAN Module

- WLAN driver, OS, Protocol Stack are included in the module.
- Controlled by easy command via UART
- Easy to implement wireless LAN, TCP/IP (socket interface), and Internet access protocol (HTTP, HTTPs) to your product

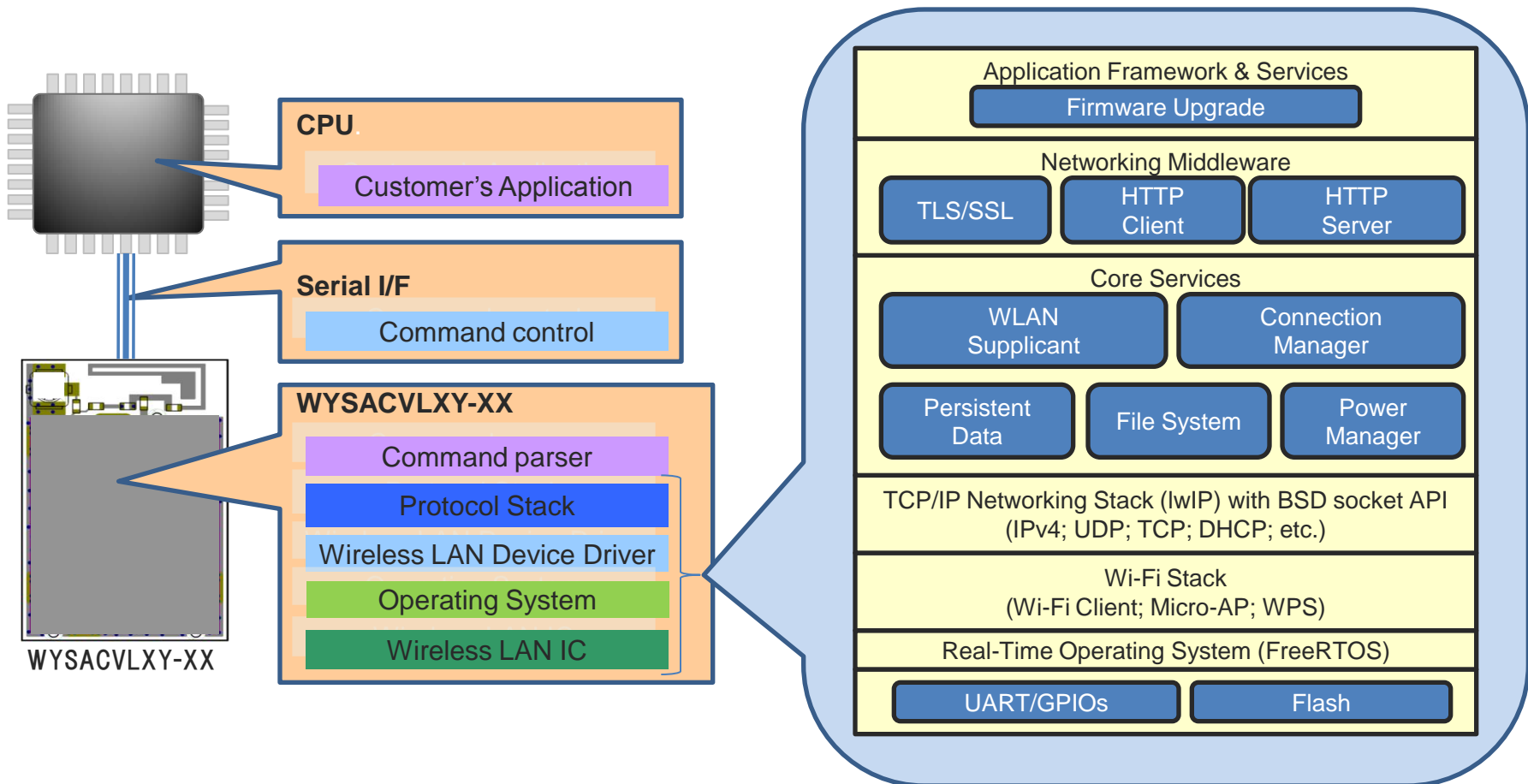

Usage Examples

■ As HTTP Client

- Communication with Web Server with HTTP Get

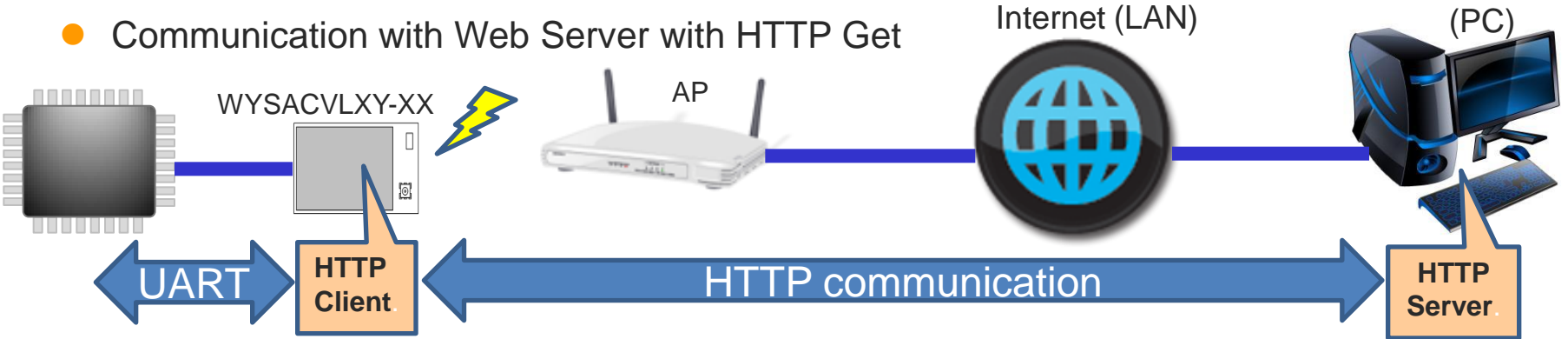

■ Socket Communication

- Communication with PC through IP Network

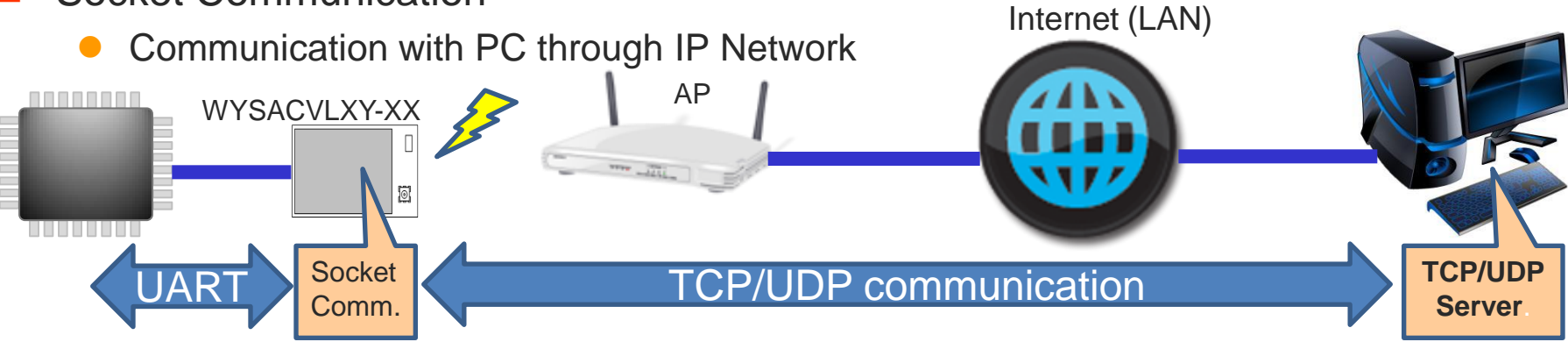

- Replace fast UART cable

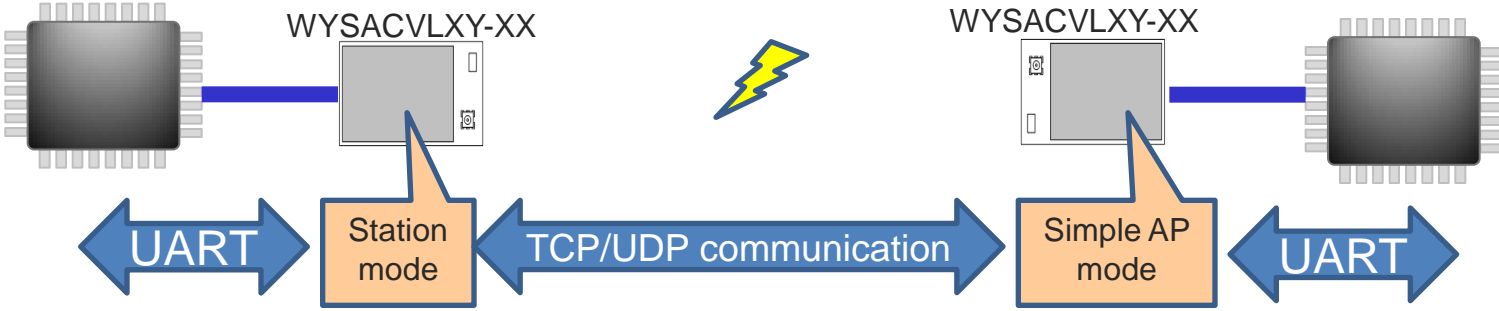

Sample Command Sequence: How to connect to an existing AP

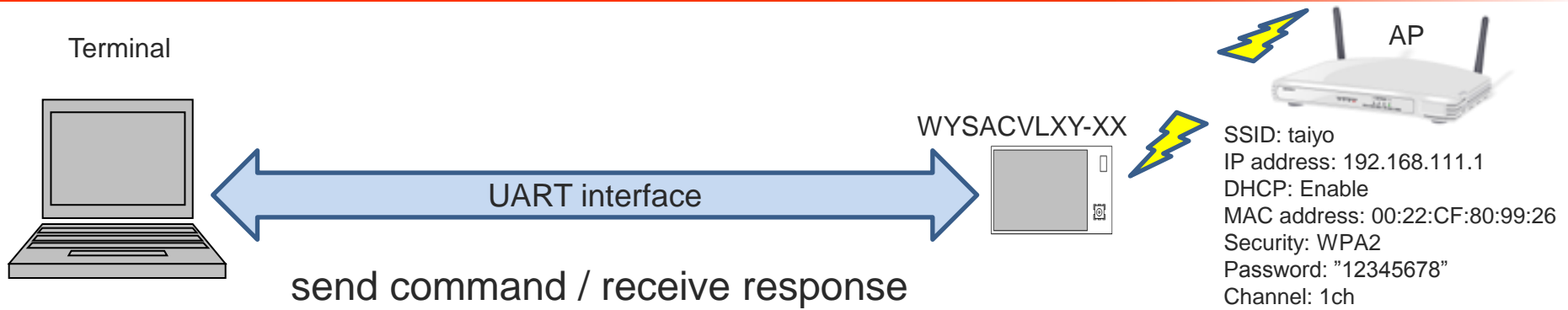

Sequence	Send command to the module	Response from the module	Brief Description
Step-1	WISC	SCR01,0022CF809926,taiyo SCR02,0022CF809927,ap-game-809927 SCR03,001D738229D4,BUFFALO-AGL300NH_G SCR04,1CB17FE59B5A,ap_demo SCR05,2EB17FE59B5A,aterm-b47dc0-gw ACK	Scan access points (5 AP exists in this case)
Step-2	WISD01	SCD01,0022CF809926,1,1,1,1,0,0,1,-46,taiyo	Confirm details of "taiyo" AP based on scan results. (BSSID="0022CF809926", channel=1ch, WMM=supported, WPS=PIN, WEP=WPA=unavailable, WPA2=available, RSSI=-46dBm、SSID="taiyo")
Step-3	WSTI101taiyo	ACK	Select SSID ("taiyo") to be connect
Step-4	WSTI1024	ACK	Select security type (WPA2)
Step-5	WSTI10312345678	ACK	Set pass phrase ("12345678")
Step-6	WSTI1041	ACK	DHCP
Step-7	WICO1	CON1,taiyo	Connect to AP -> Success to connect to "taiyo"
Step-8	WGCN	CFG0022CF809926,1,4,192.168.111.2,taiyo	Get connect info (BSSID="0022CF809926", channel=1ch, security=WPA2, IP address, SSID="taiyo")

Note:The above PRELIMINARY schedule is not guaranteed, and is subject to change.

Sample Command Sequence: How to execute HTTP GET

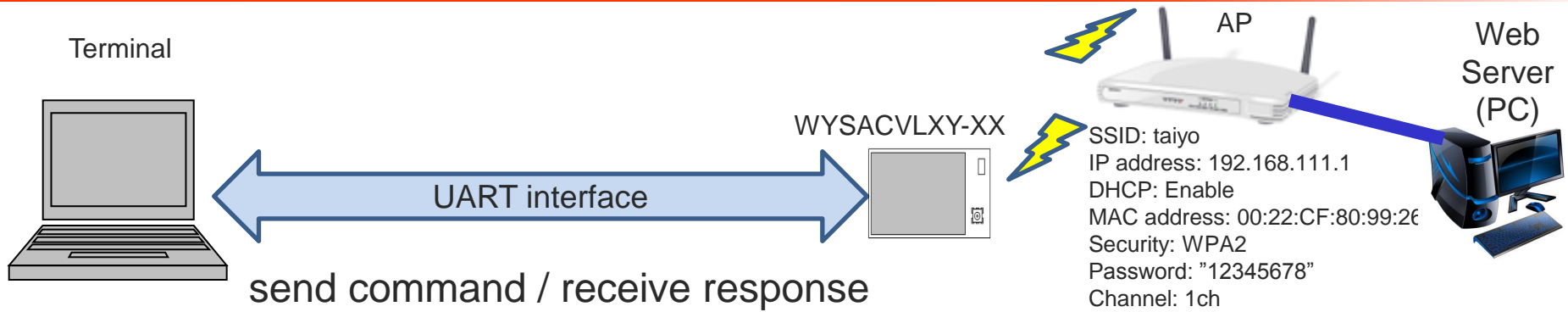

Sequence	Send command to the module	Response from the module	Brief Description
Step-1	Connect to AP (previous page)		
Step-2 (http)	WHTG01http://www.google.co.jp/	RCS01 RCT01<!doctype html><html itemscope="" itemtype="http://schema.org/WebPage" lang="ja"><head><meta content="「E^鈕 駄????~c[・オト「ワキBウウエワ?・¥?pオトAiTオ フ??ツユセウ「B” ...(snip)	HTTP GET for http://www.google.co.jp/
Step-2 (https)	WHTG01https://www.google.co.jp/	RCS01 RCT01<!doctype html><html itemscope="" itemtype="http://schema.org/WebPage" lang="ja"><head><meta content="「E^鈕 駄????~c[・オト「ワキBウウエワ?・¥?pオトAiTオ フ??ツユセウ「B” ...(snip)	HTTP GET for https://www.google.co.jp/

Note:The above PRELIMINARY schedule is not guaranteed, and is subject to change.

TAIYO YUDEN

Компания «Life Electronics» занимается поставками электронных компонентов импортного и отечественного производства от производителей и со складов крупных дистрибьюторов Европы, Америки и Азии.

С конца 2013 года компания активно расширяет линейку поставок компонентов по направлению коаксиальный кабель, кварцевые генераторы и конденсаторы (керамические, пленочные, электролитические), за счёт заключения дистрибьюторских договоров

Мы предлагаем:

- Конкурентоспособные цены и скидки постоянным клиентам.
- Специальные условия для постоянных клиентов.
- Подбор аналогов.
- Поставку компонентов в любых объемах, удовлетворяющих вашим потребностям.
- Приемлемые сроки поставки, возможна ускоренная поставка.
- Доставку товара в любую точку России и стран СНГ.
- Комплексную поставку.
- Работу по проектам и поставку образцов.
- Формирование склада под заказчика.
- Сертификаты соответствия на поставляемую продукцию (по желанию клиента).
- Тестирование поставляемой продукции.
- Поставку компонентов, требующих военную и космическую приемку.
- Входной контроль качества.
- Наличие сертификата ISO.

В составе нашей компании организован Конструкторский отдел, призванный помогать разработчикам, и инженерам.

Конструкторский отдел помогает осуществить:

- Регистрацию проекта у производителя компонентов.
- Техническую поддержку проекта.
- Защиту от снятия компонента с производства.
- Оценку стоимости проекта по компонентам.
- Изготовление тестовой платы монтаж и пусконаладочные работы.



Тел: +7 (812) 336 43 04 (многоканальный)

Email: org@lifeelectronics.ru