

NCN1154MUTGEVB

NCN1154 DP3T USB 2.0 High Speed Audio Switch Evaluation Board User's Manual

Prepared by: Bertrand RENAUD
On Semiconductor



ON Semiconductor®

<http://onsemi.com>

EVAL BOARD USER'S MANUAL

OVERVIEW

The NCN1154 is a DP3T switch for combined true-ground audio, USB 2.0 high speed data, and UART applications. It allows portable systems to use a single port to pass either USB data or audio signals from an external headset. The switch is capable of passing signals with negative voltages as low as 2 V below ground.

The NCN1154 features shunt resistors on the audio ports. These resistors are switched in when the audio channel is off

and provide a safe path to ground for any charge that may build up on the audio lines.

This reduces Pop & Click noise in the audio system. The device has an extended V_{CC} range which can operate off V_{CC} up to 4.2 V while passing true ground audio signals down to -2 V.

The NCN1154 is housed in a space saving, ultra low profile 1.7 x 2.0 x 0.5 mm 12 pin DFN package.

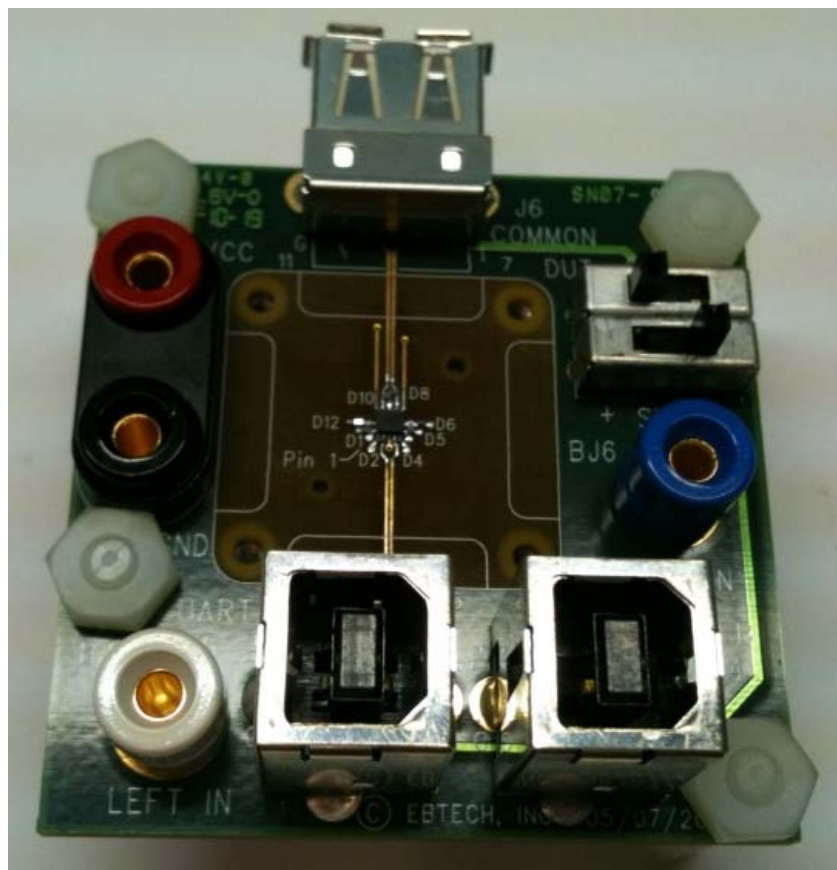

Figure 1. Board Picture

NCN1154MUTGEVB

NCN1154 – BOARD SCHEMATIC

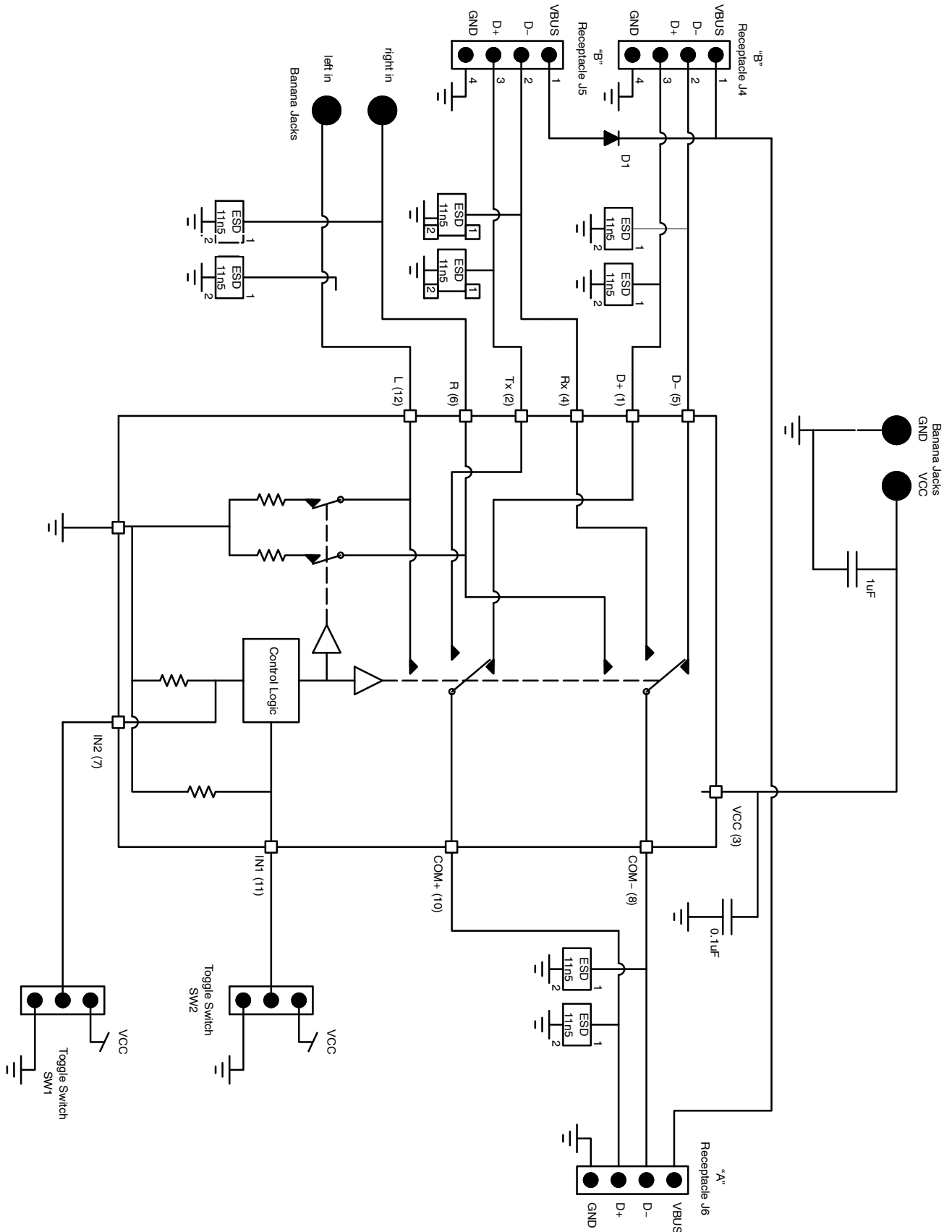

Figure 2. Board Schematic

NCN1154MUTGEVB

NCN1154 – BOARD CONNECTIONS

SUPPLY

Symbol	Description
VCC, GND	This is the positive and the return connection for power supply (Pins 3 and 9).

SETUP

Symbol	Description
SW1	This is the toggle switch for IN2 (Pin 7).
SW2	This is the toggle switch for IN1 (Pin 11).

SIGNALS

Symbol	Description
COMMON	This standard USB connector is the common data and audio lines (Pins 8 and 10).
USB	This USB connector Male A type is the high speed USB signaling path (Pins 1 and 5).
UART	This USB connector Male B type is dedicated for Tx and Rx data lines for UART signals (Pins 2 and 4).
LEFT IN	This connector is the left audio signal (Pin 12).
RIGHT IN	This connector is the right audio signal (Pin 6).

NCN1154MUTGEVB

NCN1154 – TEST PROCEDURE

Equipment needed

- Power Supply
- Digital Ohm Meter
- Desktop or Laptop with Windows XP or higher
- USB Key
- USB Headset

BACKGROUND: IN1 & IN2 TRUTH TABLE

IN1	IN2	D+, D-	R _x , T _x	L, R	L, R SHUNT
0	0	Hi Z	Hi Z	Hi Z	ON
0	1	ON	Hi Z	Hi Z	ON
1	0	Hi Z	Hi Z	ON	OFF
1	1	Hi Z	ON	Hi Z	ON

Test

1. Connect the power supply at 3.6 V from V_{CC} to GND. The supply current should be less than 35 μ A.
2. Turn SW1 and SW2 to G (ground) position
The impedance measured from COM+ to D+, Tx and L is over 10 M Ω .
The impedance measured from COM- to D-, Rx and R is over 10 M Ω .
The impedance measured from L & R to GND is closed to 118 Ω .
3. Turn SW1 to + (V_{CC}) and keep SW2 to G (ground)
The impedance measured from COM+ to D+ is closed to 5.5 Ω .
The impedance measured from COM- to D- is closed to 5.5 Ω .
The impedance measured from COM+ to Tx and L is over 10 M Ω .
The impedance measured from COM- to Rx and R is over 10 M Ω .
The impedance measured from L & R to GND is closed to 118 Ω .
4. Place a USB key connected to COMMON terminal (J6) and connect the USB terminal (J4) to the laptop or desktop.
The device is being recognized.
Remove both USB cable and USB key for next measurement.
5. Keep SW1 to + (V_{cc}) and turn SW2 to + (V_{cc})
The impedance measured from COM+ to Tx is closed to 5.5 Ω .
The impedance measured from COM- to Rx is closed to 5.5 Ω .
The impedance measured from COM+ to D+ and L is over 10 M Ω .
The impedance measured from COM- to D- and R is over 10 M Ω .
The impedance measured from L & R to GND is closed to 118 Ω .
6. Place a USB key connected to COMMON terminal (J6) and connect the UART terminal (J5) to the laptop or desktop.
The device is being recognized.
Remove both USB cable and USB key for next measurement
7. Turn SW1 to G (ground) and keep SW2 to + (V_{cc})
The impedance measured from COM+ to L is closed to 3 Ω .
The impedance measured from COM- to R is closed to 3 Ω .
The impedance measured from COM+ to D+ and Tx is over 5 M Ω .
The impedance measured from COM- to D- and Rx is over 5 M Ω .
The impedance measured from L & R to GND is over 5 M Ω .

NCN1154MUTGEVB

NCN1154 – COMPONENTS SELECTION

Input Capacitor

A 0.1 μ F X5R ceramic capacitor or larger must bypass Vcc input to the ground. This capacitor should be placed as close as possible to this input.

ESD Diode

These devices have limited built-in ESD protection, an external bi-directional ESD / IEC diode is recommended on COM+ and COM- pin. The demoboard includes six additional ESD diodes for test purpose which are not required by the application. The ESD11N is designed to protect voltage sensitive components that require ultra-low capacitance from ESD and transient voltage events. Excellent clamping capability, low capacitance, low leakage, and fast response time, make these parts ideal for ESD protection on designs where board space is at a premium. Because of its low capacitance, it is suited for use in high frequency designs such as USB 2.0 high speed and antenna line applications.

NCN1154 – BILL OF MATERIAL

Designator	Qty	Description	Value	Tolerance	Footprint	Manufacturer	Manufacturer Part Number
U1	1	IC, High Speed Switches	NA	NA	UDFN-12	ON Semiconductor	NCN1154
D1, D2, D4, D5, D6, D8, D10, D12	8	ESD Diode	NA	NA	0.6 x 0.3 mm	ON Semiconductor	ESD11N5.0ST5G
C1, C3	1	Ceramic capacitor	10 nF	$\pm 20\%$	0402	AVX Corporation	04023C103KAT2A
C2	1	Ceramic capacitor	1 μ F	$\pm 20\%$	0603	Murata	GRM188R61C105
J6	1	USB Connector Male ANG Receptable	NA	NA	A Type	Mill-Max	896-43-004-90-000000
J4, J5	2	USB Connector Male VERT Receptable	NA	NA	B Type	Molex/Waldom	67265-2001
BJ6	1	Single Banana	NA	NA	NA	Pomona Electronics	2142-6
BJ12	1	Single Banana	NA	NA	NA	Pomona Electronics	2142-9
BJ	1	Double Banana	NA	NA	NA	Pomona Electronics	2143-0
SW1, SW2	2	Switch	NA	NA	NA	ITT CANNON	OS103011MS8QP1
PCB	1	5.0 x 5.0 x 0.25 mm 2 Layers	NA	NA	NA	Any	EBT1745-01 REV: A

NCN1154 – PCB LAYOUT GUIDELINES

Electrical Layout Considerations

Implementing a high speed USD device requires paying attention on USB lines and traces to preserve signal integrity. The demonstration board serves as layout example and can support the design engineers to preserve high speed performances. Electrical layout guidelines are:

- The bypass capacitor must be placed as close as possible to the Vcc input pin for noise immunity.
- The characteristic impedance of each High Speed USB segment must be 45 Ω .
- All corresponding D+ / D- line segment pairs must be the same length.
- The use of vias to route these signals should be avoided.
- The use of turns or bends to route these signal should be avoided.
- The ground plane of the PCB will be used to determine the characteristics impedance of each line.

NCN1154MUTGEVB

NCN1154 – DEMOBOARD PCB LAYOUT

Board Reference: EBT1745-01 REV: A

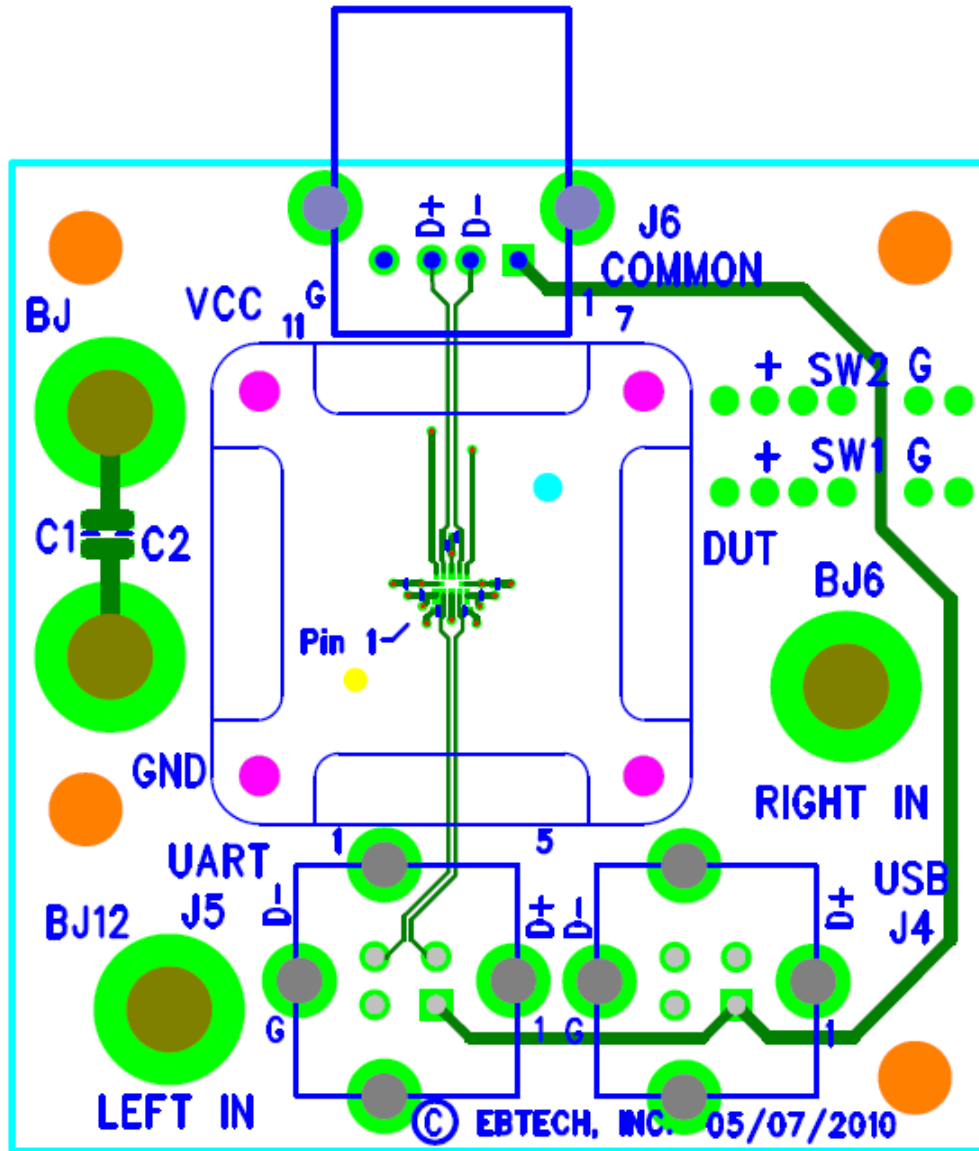

Figure 3. Top Layer Routing

NCN1154MUTGEVB

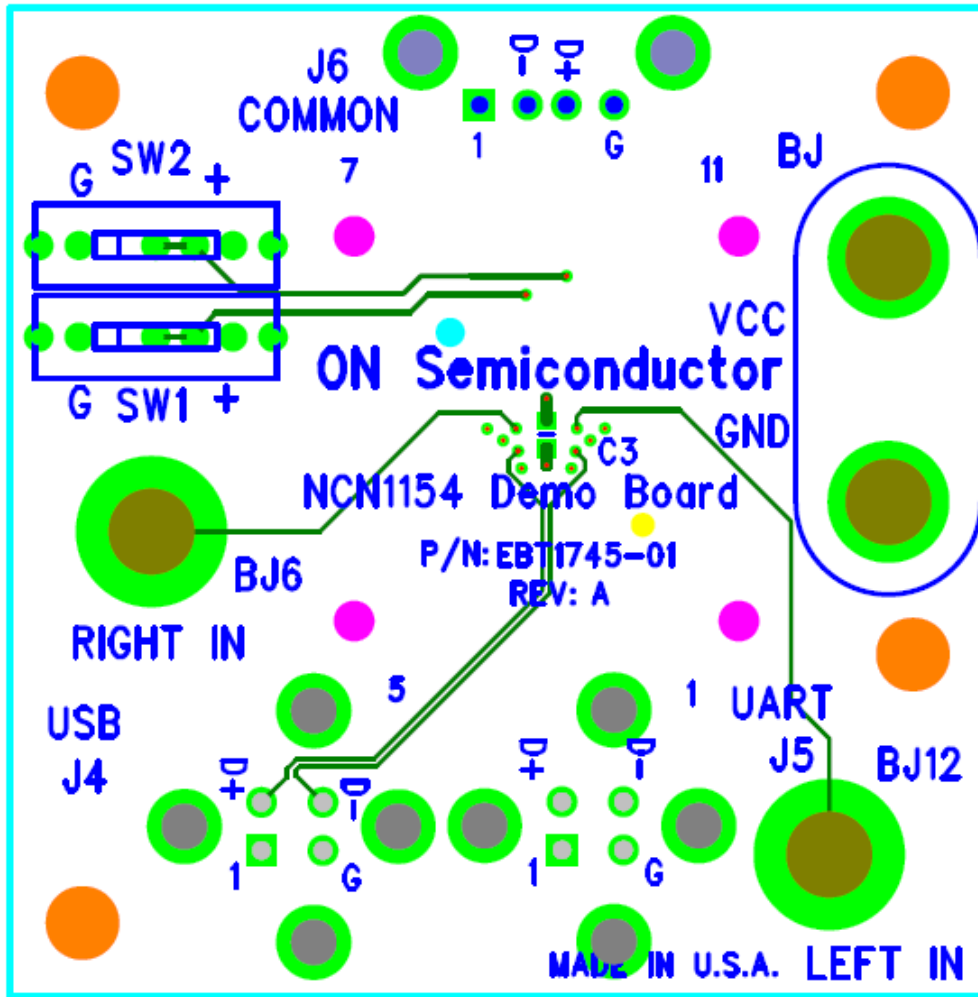



Figure 4. Bottom Layer Routing

ON Semiconductor and  are registered trademarks of Semiconductor Components Industries, LLC (SCILLC). SCILLC reserves the right to make changes without further notice to any products herein. SCILLC makes no warranty, representation or guarantee regarding the suitability of its products for any particular purpose, nor does SCILLC assume any liability arising out of the application or use of any product or circuit, and specifically disclaims any and all liability, including without limitation special, consequential or incidental damages. "Typical" parameters which may be provided in SCILLC data sheets and/or specifications can and do vary in different applications and actual performance may vary over time. All operating parameters, including "Typicals" must be validated for each customer application by customer's technical experts. SCILLC does not convey any license under its patent rights nor the rights of others. SCILLC products are not designed, intended, or authorized for use as components in systems intended for surgical implant into the body, or other applications intended to support or sustain life, or for any other application in which the failure of the SCILLC product could create a situation where personal injury or death may occur. Should Buyer purchase or use SCILLC products for any such unintended or unauthorized application, Buyer shall indemnify and hold SCILLC and its officers, employees, subsidiaries, affiliates, and distributors harmless against all claims, costs, damages, and expenses, and reasonable attorney fees arising out of, directly or indirectly, any claim of personal injury or death associated with such unintended or unauthorized use, even if such claim alleges that SCILLC was negligent regarding the design or manufacture of the part. SCILLC is an Equal Opportunity/Affirmative Action Employer. This literature is subject to all applicable copyright laws and is not for resale in any manner.

PUBLICATION ORDERING INFORMATION

LITERATURE FULFILLMENT:
 Literature Distribution Center for ON Semiconductor
 P.O. Box 5163, Denver, Colorado 80217 USA
Phone: 303-675-2175 or 800-344-3860 Toll Free USA/Canada
Fax: 303-675-2176 or 800-344-3867 Toll Free USA/Canada
Email: orderlit@onsemi.com

N. American Technical Support: 800-282-9855 Toll Free
 USA/Canada
Europe, Middle East and Africa Technical Support:
 Phone: 421 33 790 2910
Japan Customer Focus Center
 Phone: 81-3-5773-3850

ON Semiconductor Website: www.onsemi.com
Order Literature: <http://www.onsemi.com/orderlit>
 For additional information, please contact your local
 Sales Representative

Компания «Life Electronics» занимается поставками электронных компонентов импортного и отечественного производства от производителей и со складов крупных дистрибьюторов Европы, Америки и Азии.

С конца 2013 года компания активно расширяет линейку поставок компонентов по направлению коаксиальный кабель, кварцевые генераторы и конденсаторы (керамические, пленочные, электролитические), за счёт заключения дистрибьюторских договоров

Мы предлагаем:

- Конкурентоспособные цены и скидки постоянным клиентам.
- Специальные условия для постоянных клиентов.
- Подбор аналогов.
- Поставку компонентов в любых объемах, удовлетворяющих вашим потребностям.
- Приемлемые сроки поставки, возможна ускоренная поставка.
- Доставку товара в любую точку России и стран СНГ.
- Комплексную поставку.
- Работу по проектам и поставку образцов.
- Формирование склада под заказчика.
- Сертификаты соответствия на поставляемую продукцию (по желанию клиента).
- Тестирование поставляемой продукции.
- Поставку компонентов, требующих военную и космическую приемку.
- Входной контроль качества.
- Наличие сертификата ISO.

В составе нашей компании организован Конструкторский отдел, призванный помогать разработчикам, и инженерам.

Конструкторский отдел помогает осуществить:

- Регистрацию проекта у производителя компонентов.
- Техническую поддержку проекта.
- Защиту от снятия компонента с производства.
- Оценку стоимости проекта по компонентам.
- Изготовление тестовой платы монтаж и пусконаладочные работы.



Тел: +7 (812) 336 43 04 (многоканальный)
Email: org@lifeelectronics.ru