



## DC-DC Power over Ethernet Splitter 30W and 12VDC for Heaters, Illuminators and POE Cameras



### Features

- Compatible with POE75U-1UP-R
- DC Good LED
- Non-Vented Case
- DC Power and PoE/Data Output
- No 2 Finger Classification
- Power IEEE802.3af Camera
- Full Protection OTP, OCP, OVP
- Gigabit Compatible
- 1 Year Warranty

### Applications

- IP Cameras Heaters and Illuminators
- Access Controls

### Safety Approvals

- CE

### Mechanical Characteristics

- Length: 100mm (3.937in)
- Width: 56mm (2.205in)
- Height: 28mm (1.098in)
- Weight: 0.142Kg (0.313lb)

### Output Specifications

Model	Output Power		PoE Load		DC Load	
	PoE	DC	Min	Max	Min	Max
POE21-120F-R*	25.5W at 42.5-57VDC	21W at 12VDC	15mA	600mA	0.0A	1.75A

\*Model will not operate without Ultra PoE Power Injector or better

Reference files: [POE21\\_user\\_manual.pdf](#)

Phihong is not responsible for any error, and reserves the right to make changes without notice. Please visit our website at [www.phihong.com](http://www.phihong.com) for the most up-to-date specifications and contact information

**INPUT:**

Unit receives power from Pihong Ultra PoE Midspans using Cat 5e or Cat 6 wiring up to 100 meters per IEEE802.3. For information on Ultra PoE Midspans please go to [www.midspans.com](http://www.midspans.com)

**DC Input Current**

0.7A (DC) and 45VDC at maxload

**DC Input Voltage Rating**

45 – 57VDC for 12V  
Pass through POE 42.5-7V

**OUTPUT:****Regulation**

Line and Load  $\pm 2\%$

**Ripple**

120mV max at 25°C on 12V

**Efficiency**

80% min at max load 48Vinput

**O/P Voltage Protection**

In case of output over voltage overload, crowbar will short. The output can be shorted permanently without damage.

**ENVIRONMENTAL:****Temperature**

Operation	0 to +40°C
Non-operation	-20 to +65°C
Humidity	5 to 90%

**Immunity**

ESD: EN61000-4-2. Level 3  
RS: EN61000-4-3. Level 2  
Note: RS and CS tested with POE60U

**EMC**

EN55022 Class A  
FCC Part 15, Class A

**Dielectric withstand (HI-POT) Test**

Primary to secondary: 2121VDC for 1 minute, 10mA

**Insulation Resistance**

Primary to Secondary: >10M Ohm 500V DC

**FEATURES:****Indicators**

GREEN LED – Output power “ON”

**Cable**

Designed to operate up to 100 meters per IEEE 802.3, CAT 5e or CAT6

**Input and Output Data Connector**

RJ45

**Output Connector**

POE and data RJ45 Jack

**DC Output**

Center Positive Barrel 12mm x 2.1mm ID x 5.5mm OD. Tip is user changeable for other sizes



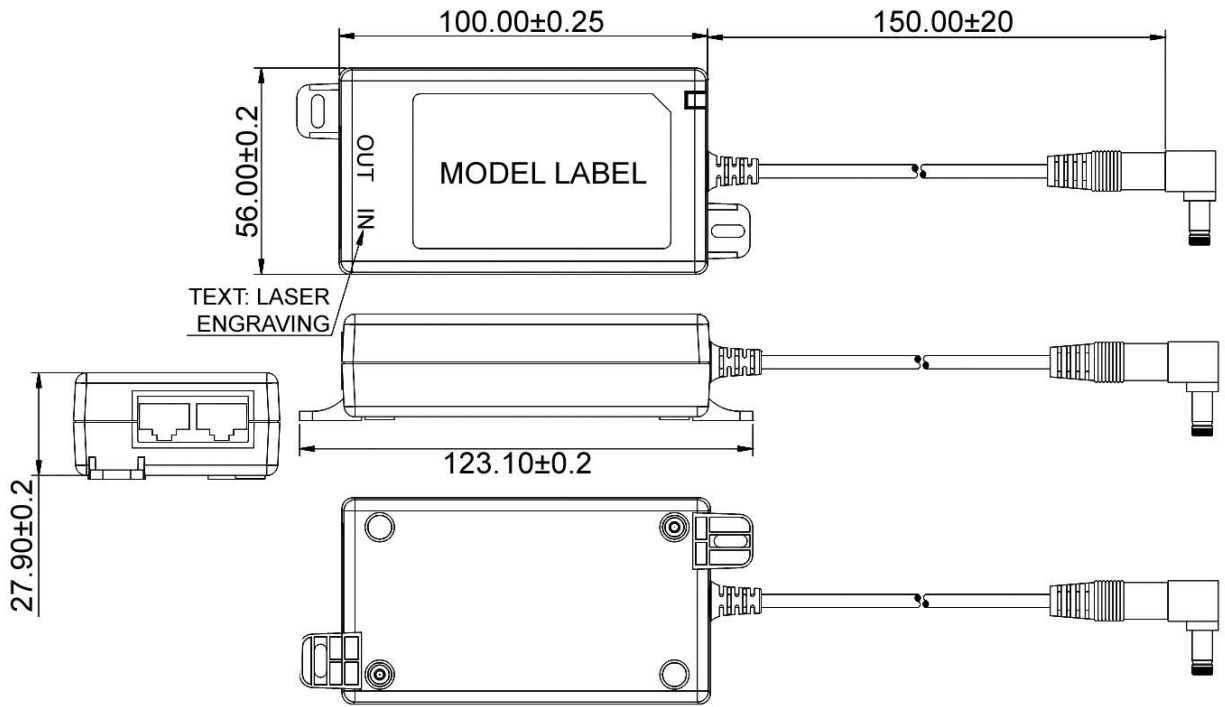

**Supplier's Declaration of Conformity**  
**47 CFR § 2.1077 Compliance Information**

Phihong USA Corporation  
47800 Fremont Boulevard  
Fremont, CA 94538  
Telephone: (510) 445-0100  
[www.phihong.com](http://www.phihong.com)

NOTE: This model has/The models in this products series have been tested and found to comply with the limits for a Class B digital device, pursuant to part 15 of the FCC Rules. These limits are designed to provide reasonable protection against harmful interference in a residential installation. This equipment generates, uses and can radiate radio frequency energy and, if not installed and used in accordance with the instructions, may cause harmful interference to radio communications. However, there is no guarantee that interference will not occur in a particular installation. If this equipment does cause harmful interference to radio or television reception, which can be determined by turning the equipment off and on, the user is encouraged to try to correct the interference by one or more of the following measures:

- Reorient or relocate the receiving antenna.
- Increase the separation between the equipment and receiver.
- Connect the equipment into an outlet on a circuit different from that to which the receiver is connected.
- Consult the dealer or an experienced radio/TV technician for help.

Changes or modifications to equipment not expressly approved by PHIHONG could void the user's authority to operate the equipment.

Компания «Life Electronics» занимается поставками электронных компонентов импортного и отечественного производства от производителей и со складов крупных дистрибьюторов Европы, Америки и Азии.

С конца 2013 года компания активно расширяет линейку поставок компонентов по направлению коаксиальный кабель, кварцевые генераторы и конденсаторы (керамические, пленочные, электролитические), за счёт заключения дистрибьюторских договоров

Мы предлагаем:

- Конкурентоспособные цены и скидки постоянным клиентам.
- Специальные условия для постоянных клиентов.
- Подбор аналогов.
- Поставку компонентов в любых объемах, удовлетворяющих вашим потребностям.
- Приемлемые сроки поставки, возможна ускоренная поставка.
- Доставку товара в любую точку России и стран СНГ.
- Комплексную поставку.
- Работу по проектам и поставку образцов.
- Формирование склада под заказчика.
- Сертификаты соответствия на поставляемую продукцию (по желанию клиента).
- Тестирование поставляемой продукции.
- Поставку компонентов, требующих военную и космическую приемку.
- Входной контроль качества.
- Наличие сертификата ISO.

В составе нашей компании организован Конструкторский отдел, призванный помогать разработчикам, и инженерам.

Конструкторский отдел помогает осуществить:

- Регистрацию проекта у производителя компонентов.
- Техническую поддержку проекта.
- Защиту от снятия компонента с производства.
- Оценку стоимости проекта по компонентам.
- Изготовление тестовой платы монтаж и пусконаладочные работы.



Тел: +7 (812) 336 43 04 (многоканальный)  
Email: [org@lifeelectronics.ru](mailto:org@lifeelectronics.ru)