

Data Sheet

Rev. 1.04 / March 2013

ZSPM9010

Ultra-Compact, High-Performance DrMOS Device



Power Management



Power and Precision

ZSPM9010

Ultra-Compact, High-Performance, High-Frequency DrMOS



Brief Description

The ZSPM9010 DrMOS is a fully optimized, ultra-compact, integrated MOSFET plus driver power stage solution for high-current, high-frequency, synchronous buck DC-DC applications. The ZSPM9010 incorporates a driver IC, two power MOSFETs, and a bootstrap Schottky diode in a thermally enhanced, ultra-compact PQFN40 package (6mmx6mm).

With an integrated approach, the ZSPM9010's complete switching power stage is optimized for driver and MOSFET dynamic performance, system inductance, and power MOSFET $R_{DS(ON)}$. It uses innovative high-performance MOSFET technology, which dramatically reduces switch ringing, eliminating the snubber circuit in most buck converter applications.

An innovative driver IC with reduced dead times and propagation delays further enhances performance. A thermal warning function (THWN) warns of potential over-temperature situations. The ZSPM9010 also incorporates features such as Skip Mode (SMOD) for improved light-load efficiency with a tri-state 3.3V pulse-width modulation (PWM) input for compatibility with a wide range of PWM controllers.

The ZSPM9010 DrMOS is compatible with ZMDI's ZSPM1000, a leading-edge configurable digital power-management system controller for non-isolated point-of-load (POL) supplies.

Benefits

- Fully optimized system efficiency: >93% peak
- Clean switching waveforms with minimal ringing
- 72% space-saving compared to conventional discrete solutions
- Optimized for use with ZMDI's ZSPM1000 true digital PWM controller

Features

- Based on the Intel® 4.0 DrMOS standard
- High-current handling: up to 50A
- High-performance copper-clip package
- Tri-state 3.3V PWM input driver
- Skip Mode (low-side gate turn-off) input (SMOD#)
- Warning flag for over-temperature conditions
- Driver output disable function (DISB# pin)
- Internal pull-up and pull-down for SMOD# and DISB# inputs, respectively
- Integrated Schottky diode technology in the low-side MOSFET
- Integrated bootstrap Schottky diode
- Adaptive gate drive timing for shoot-through protection
- Under-voltage lockout (UVLO)
- Optimized for switching frequencies up to 1MHz

Available Support

- ZSPM8010-KIT: Open-Loop Evaluation Board for ZSPM9010

Physical Characteristics

- Operation temperature: -40°C to +125°C
- V_{IN} : 3V to 15V (typical 12V)
- I_{OUT} : 40A (average), 50A (maximum)
- Low-profile SMD package: 6mmx6mm PQFN40
- ZMDI green packaging and RoHS compliant

Typical Application

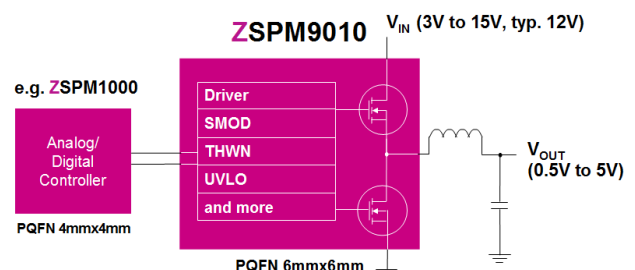

For more information, contact ZMDI via SPM@zmdi.com.

ZSPM9010

Ultra-Compact, High-Performance, High-Frequency DrMOS

ZMDI

The Analog Mixed Signal Company



ZSPM9010 Block Diagram

- Typical Applications**
- Telecom switches
 - Servers and storage
 - Desktop computers
 - Workstations
 - High-performance gaming motherboards
 - Base stations
 - Network routers
 - Industrial applications

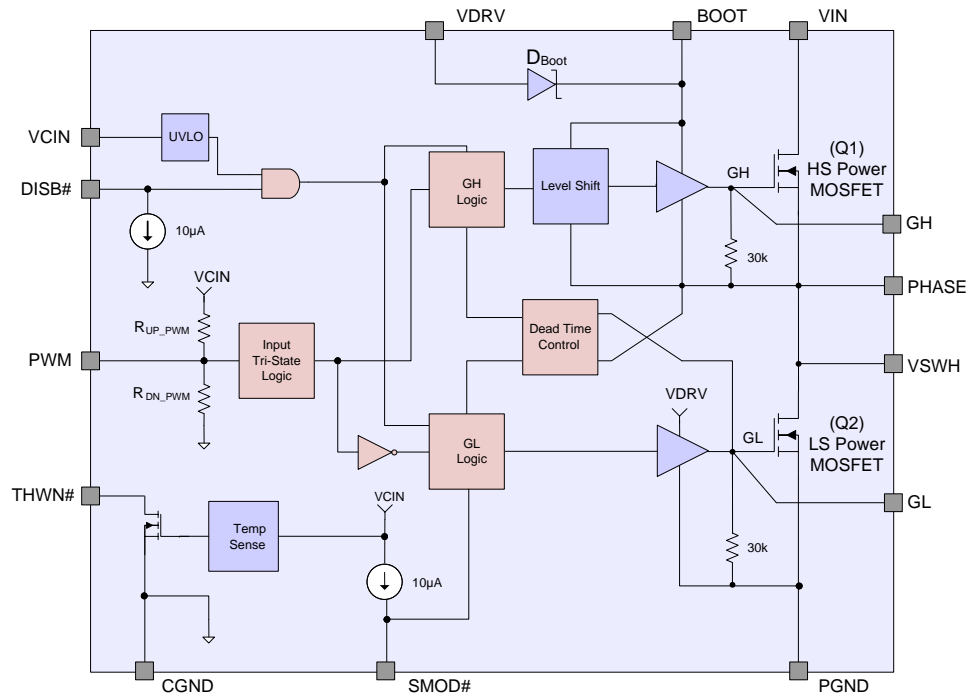

Ordering Information

Product Sales Code	Description	Package
ZSPM9010ZA1R	ZSPM9010 Lead-Free PQFN40 — Temperature range: -40°C to +125°C	Reel
ZSPM8010-KIT	Open-Loop Evaluation Board for ZSPM9010	Kit

Sales and Further Information		www.zmdi.com	SPM@zmdi.com
Zentrum Mikroelektronik Dresden AG Global Headquarters Grenzstrasse 28 01109 Dresden, Germany Central Office: Phone +49.351.8822.306 Fax +49.351.8822.337	ZMD America, Inc. 1525 McCarthy Blvd., #212 Milpitas, CA 95035-7453 USA USA Phone 1.855.275.9634 Phone +1.408.883.6310 Fax +1.408.883.6358	Zentrum Mikroelektronik Dresden AG, Japan Office 2nd Floor, Shinbashi Tokyu Bldg. 4-21-3, Shinbashi, Minato-ku Tokyo, 105-0004 Japan Phone +81.3.6895.7410 Fax +81.3.6895.7301	ZMD FAR EAST, Ltd. 3F, No. 51, Sec. 2, Keelung Road 11052 Taipei Taiwan Phone +886.2.2377.8189 Fax +886.2.2377.8199
Zentrum Mikroelektronik Dresden AG, Korea Office U-space 1 Building 11th Floor, Unit JA-1102 670 Sampyeong-dong Bundang-gu, Seongnam-si Gyeonggi-do, 463-400 Korea Phone +82.31.950.7679 Fax +82.504.841.3026	European Technical Support Phone +49.351.8822.7.772 Fax +49.351.8822.87.772		
European Sales (Stuttgart) Phone +49.711.674517.55 Fax +49.711.674517.87955	DISCLAIMER: This information applies to a product under development. Its characteristics and specifications are subject to change without notice. Zentrum Mikroelektronik Dresden AG (ZMD AG) assumes no obligation regarding future manufacture unless otherwise agreed to in writing. The information furnished hereby is believed to be true and accurate. However, under no circumstances shall ZMD AG be liable to any customer, licensee, or any other third party for any special, indirect, incidental, or consequential damages of any kind or nature whatsoever arising out of or in any way related to the furnishing, performance, or use of this technical data. ZMD AG hereby expressly disclaims any liability of ZMD AG to any customer, licensee or any other third party, and any such customer, licensee and any other third party hereby waives any liability of ZMD AG for any damages in connection with or arising out of the furnishing, performance or use of this technical data, whether based on contract, warranty, tort (including negligence), strict liability, or otherwise.		



Contents

1	IC Characteristics	6
1.1.	Absolute Maximum Ratings	6
1.2.	Recommended Operating Conditions	7
1.3.	Electrical Parameters	7
1.4.	Typical Performance Characteristics	10
2	Functional Description	15
2.1.	VDRV and Disable (DISB#)	16
2.2.	Thermal Warning Flag (THWN#)	17
2.3.	Tri-State PWM Input	17
2.4.	Adaptive Gate Drive Circuit	19
2.5.	Skip Mode (SMOD#)	19
2.6.	PWM	21
3	Application Design	22
3.1.	Supply Capacitor Selection	22
3.2.	Bootstrap Circuit	22
3.3.	VCIN Filter	22
3.4.	Power Loss and Efficiency Testing Procedures	23
4	Pin Configuration and Package	25
4.1.	Available Packages	25
4.2.	Pin Description	26
4.3.	Package Dimensions	27
5	Circuit Board Layout Considerations	28
6	Ordering Information	29
7	Related Documents	30
8	Document Revision History	30

List of Figures

Figure 1.1	Safe Operating Area	10
Figure 1.2	Module Power Loss vs. Output Current	10
Figure 1.3	Power Loss vs. Switching Frequency	10
Figure 1.4	Power Loss vs. Input Voltage	10
Figure 1.5	Power Loss vs. Driver Supply Voltage	11
Figure 1.6	Power Loss vs. Output Voltage	11
Figure 1.7	Power Loss vs. Output Inductance	11
Figure 1.8	Driver Supply Current vs. Frequency	11
Figure 1.9	Driver Supply Current vs. Driver Supply Voltage	12
Figure 1.10	Driver Supply Current vs. Output Current	12
Figure 1.11	PWM Thresholds vs. Driver Supply Voltage	12

ZSPM9010

Ultra-Compact, High-Performance, High-Frequency DrMOS



The Analog Mixed Signal Company



Figure 1.12	PWM Thresholds vs. Temperature	12
Figure 1.13	SMOD# Thresholds vs. Driver Supply Voltage.....	13
Figure 1.14	SMOD# Thresholds vs. Temperature.....	13
Figure 1.15	SMOD# Pull-Up Current vs. Temperature	13
Figure 1.16	Disable Thresholds vs. Driver Supply Voltage	13
Figure 1.17	Disable Thresholds vs. Temperature.....	14
Figure 1.18	Disable Pull-Down Current vs. Temperature	14
Figure 2.1	Typical Application Circuit with PWM Control.....	15
Figure 2.2	ZSPM9010 Block Diagram	16
Figure 2.3	Thermal Warning Flag (THWN) Operation	17
Figure 2.4	PWM and Tri-State Timing Diagram.....	18
Figure 2.5	SMOD# Timing Diagram.....	20
Figure 2.6	PWM Timing	21
Figure 3.1	Power Loss Measurement Block Diagram	22
Figure 3.2	V _{CIN} Filter Block Diagram	23
Figure 4.1	Pin-out PQFN40 Package	25
Figure 4.2	PQFN40 Physical Dimensions and Recommended Footprint.....	27
Figure 5.1	PCB Layout Example.....	29

List of Tables

Table 2.1	UVLO and Disable Logic	17
Table 2.2	SMOD# Logic.....	20



1 IC Characteristics

1.1. Absolute Maximum Ratings

The absolute maximum ratings are stress ratings only. The device might not function or be operable above the recommended operating conditions. Stresses exceeding the absolute maximum ratings might also damage the device. In addition, extended exposure to stresses above the recommended operating conditions might affect device reliability. ZMDI does not recommend designing to the “Absolute Maximum Ratings.”

PARAMETER	SYMBOL	CONDITIONS	MIN	MAX	UNITS
Maximum Voltage to CGND – VCIN, VDRV, DISB#, PWM, SMOD#, GL, THWN# pins			-0.3	6.0	V
Maximum Voltage to PGND or CGND – VIN pin			-0.3	25.0	V
Maximum Voltage to VSWH or PHASE – BOOT, GH pins			-0.3	6.0	V
Maximum Voltage to CGND – BOOT, PHASE, GH pins			-0.3	25.0	V
Maximum Voltage to CGND or PGND – VSWH pin		DC only	-0.3	25.0	V
Maximum Voltage to PGND – VSWH pin		< 20ns	-8.0	25.0	V
Maximum Voltage to VDRV – BOOT pin				22.0	V
Maximum Sink Current – THWN# pin	$I_{THWN\#}$		-0.1	7.0	mA
Maximum Average Output Current ¹⁾	$I_{OUT(AV)}$	$f_{SW}=300kHz, V_{IN}=12V, V_{OUT}=1.0V$		50	A
		$f_{SW}=1MHz, V_{IN}=12V, V_{OUT}=1.0V$		45	A
Junction-to-PCB Thermal Resistance	θ_{JPCB}			3.5	°C/W
Ambient Temperature Range	T_{AMB}		-40	+125	°C
Maximum Junction Temperature	T_{JMAX}			+150	°C
Storage Temperature Range	T_{STOR}		-55	+150	°C
Electrostatic Discharge Protection	ESD	Human Body Model, JESD22-A114	2000		V
		Charged Device Model, JESD22-C101	1000		V
¹⁾ $I_{OUT(AV)}$ is rated using a DrMOS Evaluation Board, $T_{AMB} = 25^{\circ}C$, natural convection cooling. This rating is limited by the peak DrMOS temperature, $T_{JMAX} = 150^{\circ}C$, and varies depending on operating conditions, PCB layout, and PCB board to ambient thermal resistance.					



1.2. Recommended Operating Conditions

The “Recommended Operating Conditions” table defines the conditions for actual device operation. Recommended operating conditions are specified to ensure optimal performance to the datasheet specifications. ZMDI does not recommend exceeding them or designing to the “Absolute Maximum Ratings.”

PARAMETER	SYMBOL	CONDITIONS	MIN	TYP	MAX	UNITS
Control Circuit Supply Voltage	V_{CIN}		4.5	5.0	5.5	V
Gate Drive Circuit Supply Voltage	V_{DRV}		4.5	5.0	5.5	V
Output Stage Supply Voltage	V_{IN}		3.0	12.0	15.0	V

1.3. Electrical Parameters

Typical values are $V_{IN} = 12V$, $V_{DRV} = 12V$, and $T_{AMB} = +25^{\circ}C$ unless otherwise noted.

PARAMETER	SYMBOL	CONDITIONS	MIN	TYP	MAX	UNITS
Basic Operation						
Quiescent Current	I_Q	$I_Q = I_{VCIN} + I_{VDRV}$, PWM=LOW or HIGH or float			2	mA
Under-Voltage Lock-Out						
UVLO Threshold	UVLO	VCIN rising	2.9	3.1	3.3	V
UVLO Hysteresis	UVLO_Hyst			0.4		V
PWM Input						
Pull-Up Impedance	R_{UP_PWM}	($V_{CIN} = V_{DRV} = 5V \pm 10\%$)		26		k Ω
Pull-Down Impedance	R_{DN_PWM}	($V_{CIN} = V_{DRV} = 5V \pm 10\%$)		12		k Ω
PWM High-Level Voltage	V_{IH_PWM}	($V_{CIN} = V_{DRV} = 5V \pm 10\%$)	1.88	2.25	2.61	V
		($V_{CIN} = V_{DRV} = 5V \pm 5\%$)	2.00	2.25	2.50	V
Tri-state Upper Threshold	V_{TRI_HI}	($V_{CIN} = V_{DRV} = 5V \pm 10\%$)	1.84	2.20	2.56	V
		($V_{CIN} = V_{DRV} = 5V \pm 5\%$)	1.94	2.20	2.46	V
Tri-state Lower Threshold	V_{TRI_LO}	($V_{CIN} = V_{DRV} = 5V \pm 10\%$)	0.70	0.95	1.19	V
		($V_{CIN} = V_{DRV} = 5V \pm 5\%$)	0.75	0.95	1.15	V
PWM Low-Level Voltage	V_{IL_PWM}	($V_{CIN} = V_{DRV} = 5V \pm 10\%$)	0.62	0.85	1.13	V
		($V_{CIN} = V_{DRV} = 5V \pm 5\%$)	0.66	0.85	1.09	V
Tri-state Shutoff Time	$t_{d_HOLD-OFF}$			160	200	ns
Tri-state Open Voltage	V_{HIZ_PWM}	($V_{CIN} = V_{DRV} = 5V \pm 10\%$)	1.40	1.60	1.90	V
		($V_{CIN} = V_{DRV} = 5V \pm 5\%$)	1.45	1.60	1.80	V

ZSPM9010

Ultra-Compact, High-Performance, High-Frequency DrMOS



The Analog Mixed Signal Company



PARAMETER	SYMBOL	CONDITIONS	MIN	TYP	MAX	UNITS
DISB# Input						
High-Level Input Voltage	$V_{IH_DISB\#}$		2			V
Low-Level Input Voltage	$V_{IL_DISB\#}$				0.8	V
Pull-Down Current	I_{PLD}			10		μ A
Propagation Delay DISB#, GL Transition from HIGH to LOW	t_{PD_DISBL}	PWM=GND, LSE=1		25		ns
Propagation Delay DISB#, GL Transition from LOW to HIGH	t_{PD_DISBH}	PWM=GND, LSE=1		25		ns
SMOD# Input						
High-Level Input Voltage	$V_{IH_SMOD\#}$		2			V
Low-Level Input Voltage	$V_{IL_SMOD\#}$				0.8	V
Pull-Up Current	I_{PLU}			10		μ A
Propagation Delay SMOD#, GL Transition from HIGH to LOW	t_{PD_SLGLL}	PWM=GND, DISB#=1		10		ns
Propagation Delay SMOD#, GL Transition from LOW to HIGH	t_{PD_SHGLH}	PWM=GND, DISB#=1		10		ns
Thermal Warning Flag						
Activation Temperature	T_{ACT}			150		$^{\circ}$ C
Reset Temperature	T_{RST}			135		$^{\circ}$ C
Pull-Down Resistance	R_{THWN}	$I_{PLD}=5\text{mA}$		30		Ω
250ns Timeout Circuit						
Timeout Delay Between GH Transition from HIGH to LOW and GL Transition from LOW to HIGH	$t_{D_TIMEOUT}$	SW=0V		250		ns

ZSPM9010

Ultra-Compact, High-Performance, High-Frequency DrMOS



The Analog Mixed Signal Company



PARAMETER	SYMBOL	CONDITIONS	MIN	TYP	MAX	UNITS
High-Side Driver						
Output Impedance, Sourcing	R _{SOURCE_GH}	Source Current=100mA		1		Ω
Output Impedance, Sinking	R _{SINK_GH}	Sink Current=100mA		0.8		Ω
Rise Time for GH=10% to 90%	t _{R_GH}			6		ns
Fall Time for GH=90% to 10%	t _{F_GH}			5		ns
LS to HS Deadband Time: GL going LOW to GH going HIGH, 1V GL to 10% GH	t _{D_DEADON}			10		ns
PWM LOW Propagation Delay: PWM going LOW to GH going LOW, V _{IL_PWM} to 90% GH	t _{PD_PLGHL}			16	30	ns
PWM HIGH Propagation Delay with SMOD# Held LOW: PWM going HIGH to GH going HIGH, V _{IH_PWM} to 10% GH	t _{PD_PHGHH}	SMOD# = LOW		30		ns
Propagation Delay Exiting Tri-state: PWM (from Tri-state) going HIGH to GH going HIGH, V _{IH_PWM} to 10% GH	t _{PD_TSGHH}			30		ns
Low-Side Driver						
Output Impedance, Sourcing	R _{SOURCE_GL}	Source Current=100mA		1		Ω
Output Impedance, Sinking	R _{SINK_GL}	Sink Current=100mA		0.5		Ω
Rise Time for GL = 10% to 90%	t _{R_GL}			20		ns
Fall Time for GL = 90% to 10%	t _{F_GL}			13		ns
HS to LS Deadband Time: SW going LOW to GL going HIGH, 2.2V SW to 10% GL	t _{D_DEADOFF}			12		ns
PWM-HIGH Propagation Delay: PWM going HIGH to GL going LOW, V _{IH_PWM} to 90% GL	t _{PD_PHGLL}			9	25	ns
Propagation Delay Exiting Tri-state: PWM (from Tri-state) going LOW to GL going HIGH, V _{IL_PWM} to 10% GL	t _{PD_TSLGH}			20		ns
Boot Diode						
Forward-Voltage Drop	V _F	I _F =10mA		0.35		V
Breakdown Voltage	V _R	I _R =1mA	22			V

ZSPM9010

Ultra-Compact, High-Performance, High-Frequency DrMOS



The Analog Mixed Signal Company



1.4. Typical Performance Characteristics

Test conditions: $V_{IN}=12V$, $V_{OUT}=1.0V$, $V_{CIN}=5V$, $V_{DRV}=5V$, $L_{OUT}=320nH$, $T_{AMB}=25^{\circ}C$, and natural convection cooling, unless otherwise specified.

Figure 1.1 Safe Operating Area

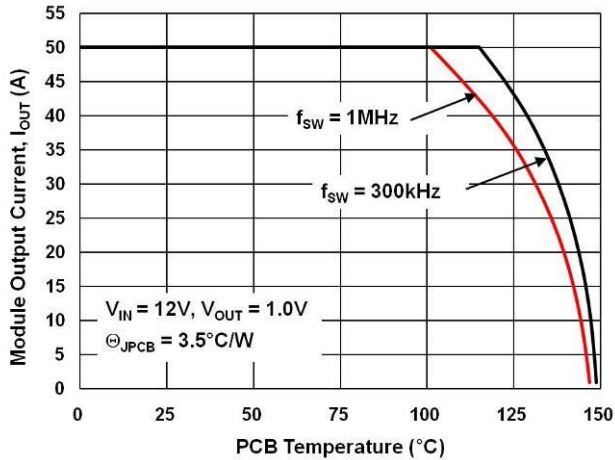

Figure 1.2 Module Power Loss vs. Output Current

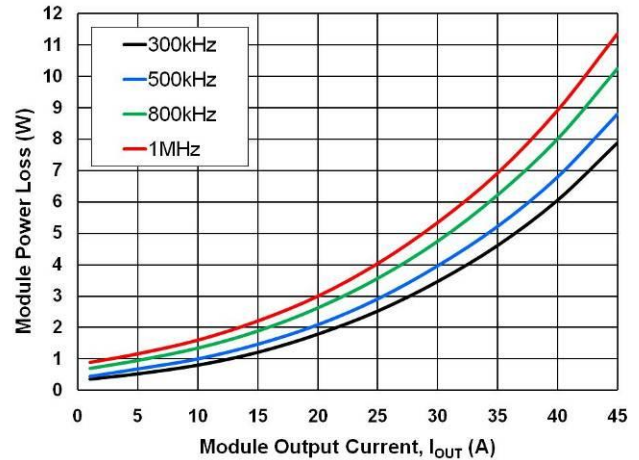

Figure 1.3 Power Loss vs. Switching Frequency

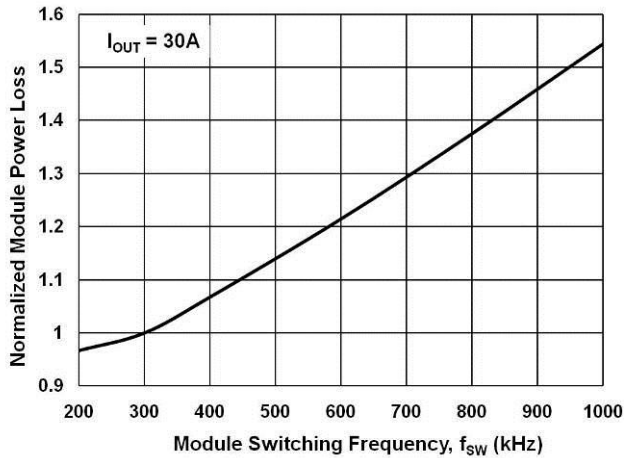
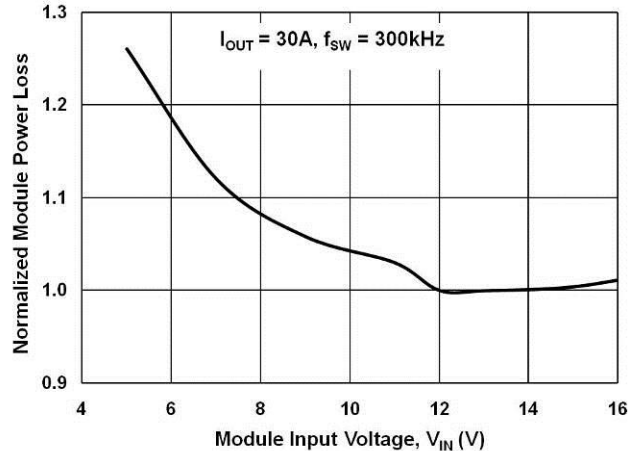

Figure 1.4 Power Loss vs. Input Voltage



ZSPM9010

Ultra-Compact, High-Performance, High-Frequency DrMOS



The Analog Mixed Signal Company



Figure 1.5 Power Loss vs. Driver Supply Voltage

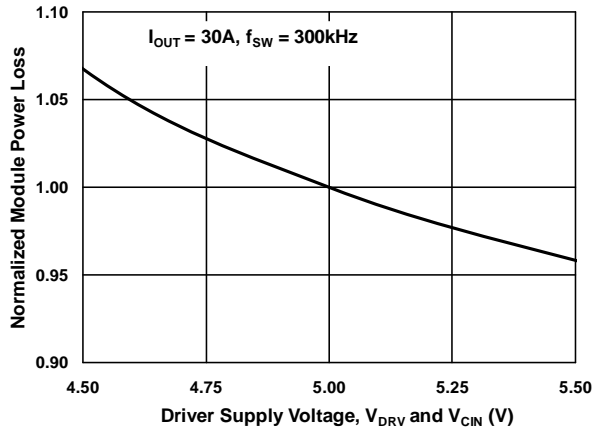

Figure 1.6 Power Loss vs. Output Voltage

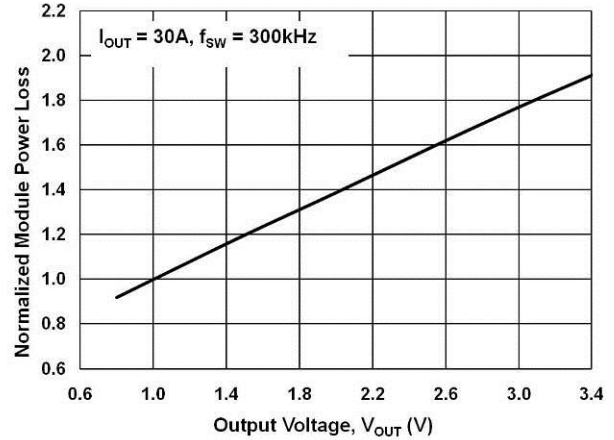

Figure 1.7 Power Loss vs. Output Inductance

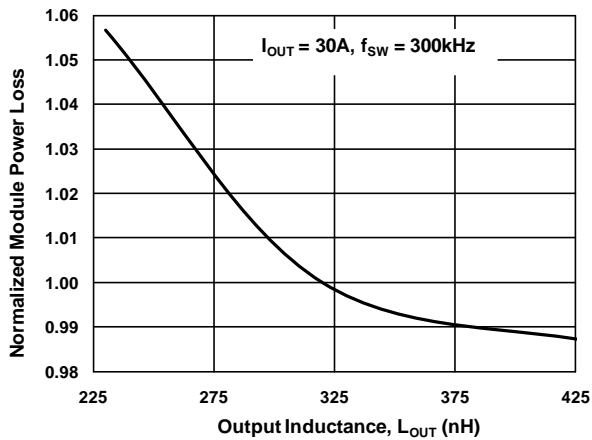
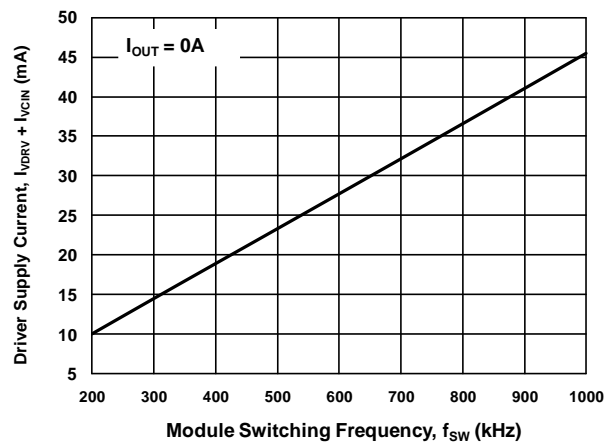

Figure 1.8 Driver Supply Current vs. Frequency



ZSPM9010

Ultra-Compact, High-Performance, High-Frequency DrMOS



Figure 1.9 Driver Supply Current vs. Driver Supply Voltage

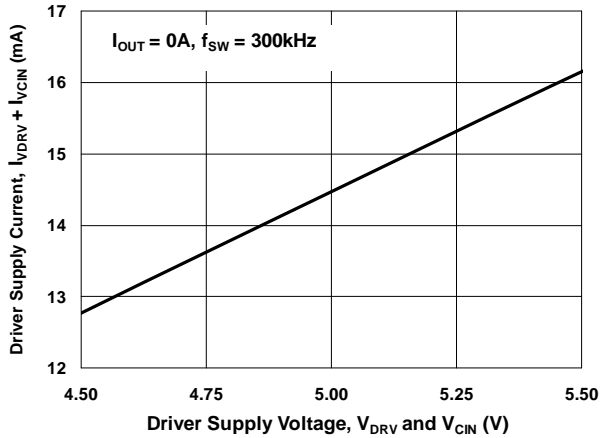

Figure 1.10 Driver Supply Current vs. Output Current

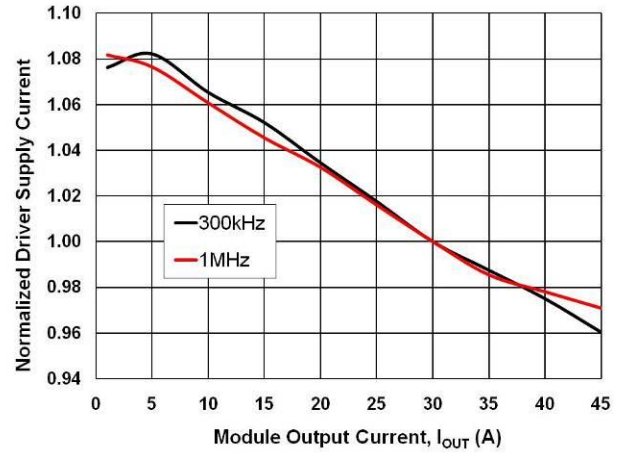

Figure 1.11 PWM Thresholds vs. Driver Supply Voltage

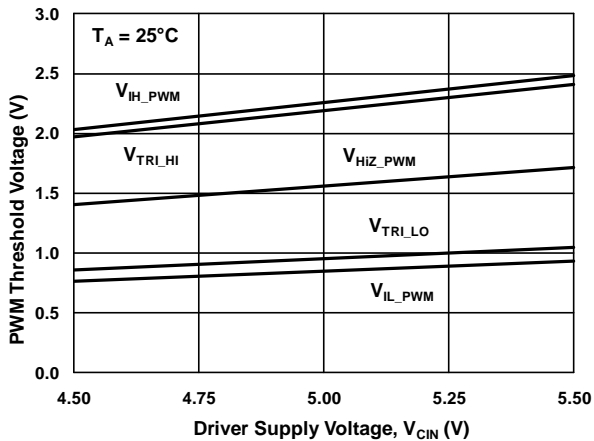
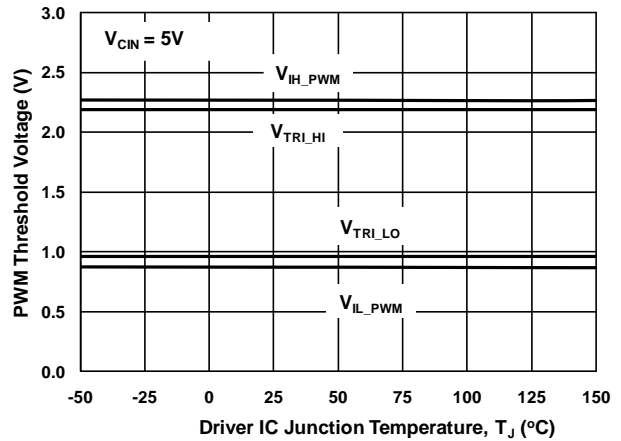

Figure 1.12 PWM Thresholds vs. Temperature



ZSPM9010

Ultra-Compact, High-Performance, High-Frequency DrMOS



The Analog Mixed Signal Company



Figure 1.13 SMOD# Thresholds vs. Driver Supply Voltage

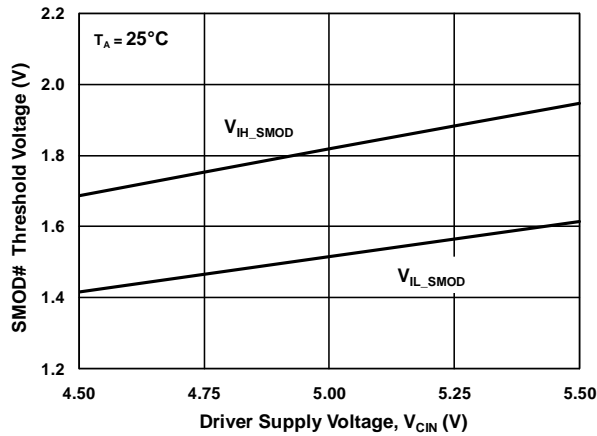

Figure 1.14 SMOD# Thresholds vs. Temperature

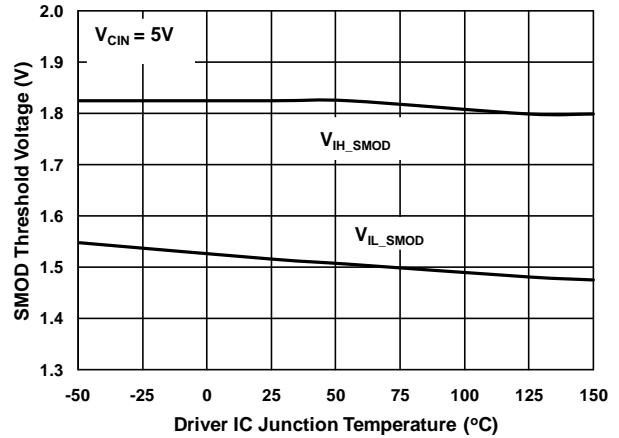

Figure 1.15 SMOD# Pull-Up Current vs. Temperature

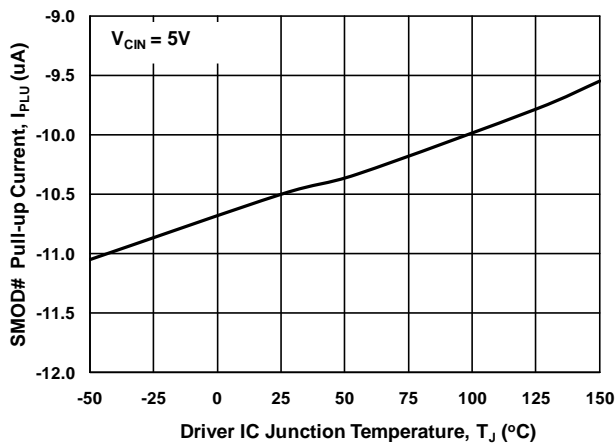
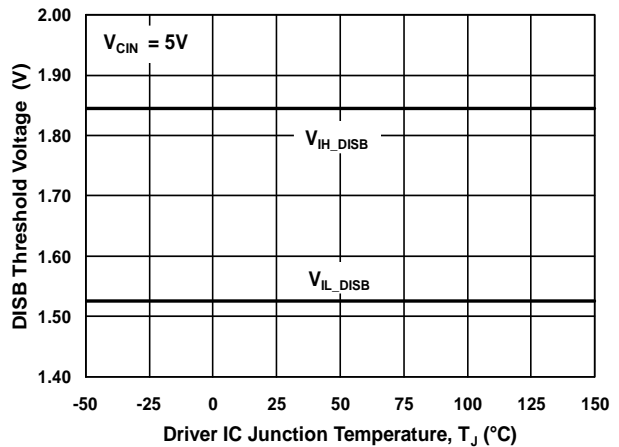

Figure 1.16 Disable Thresholds vs. Driver Supply Voltage



ZSPM9010

Ultra-Compact, High-Performance, High-Frequency DrMOS



The Analog Mixed Signal Company



Figure 1.17 Disable Thresholds vs. Temperature

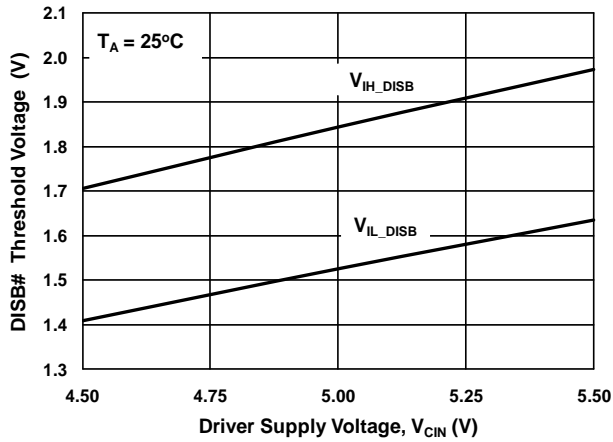
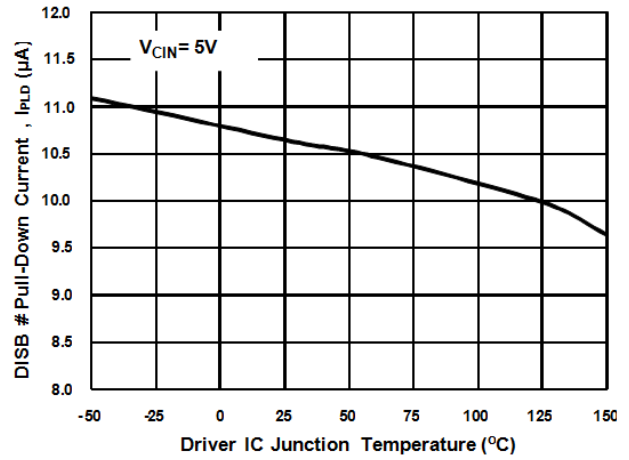

Figure 1.18 Disable Pull-Down Current vs. Temperature



ZSPM9010

Ultra-Compact, High-Performance, High-Frequency DrMOS



2 Functional Description

The ZSPM9010 is a driver-plus-FET module optimized for the synchronous buck converter topology. A single PWM input signal is all that is required to properly drive the high-side and the low-side MOSFETs. It is capable of driving speeds up to 1MHz.

Figure 2.1 Typical Application Circuit with PWM Control

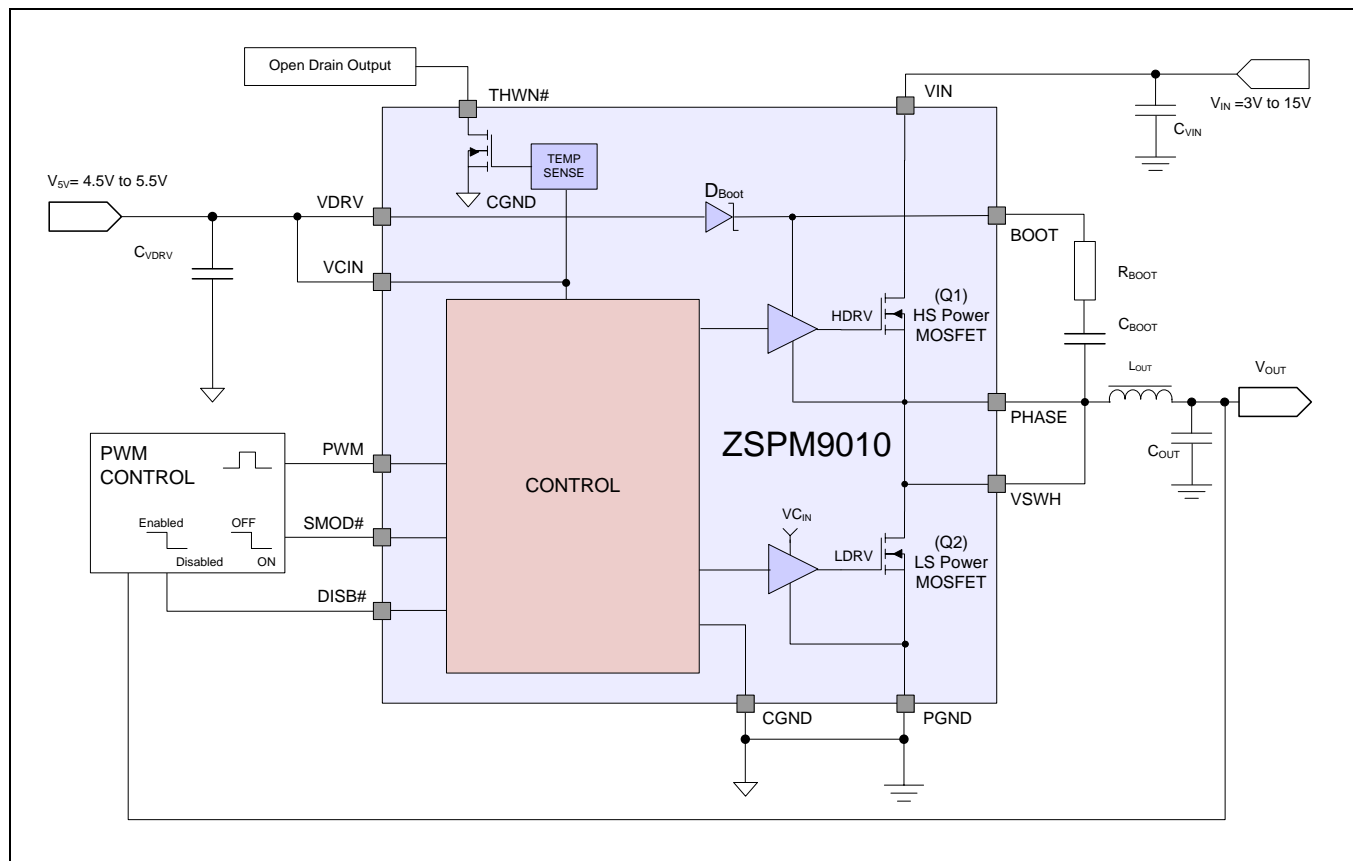
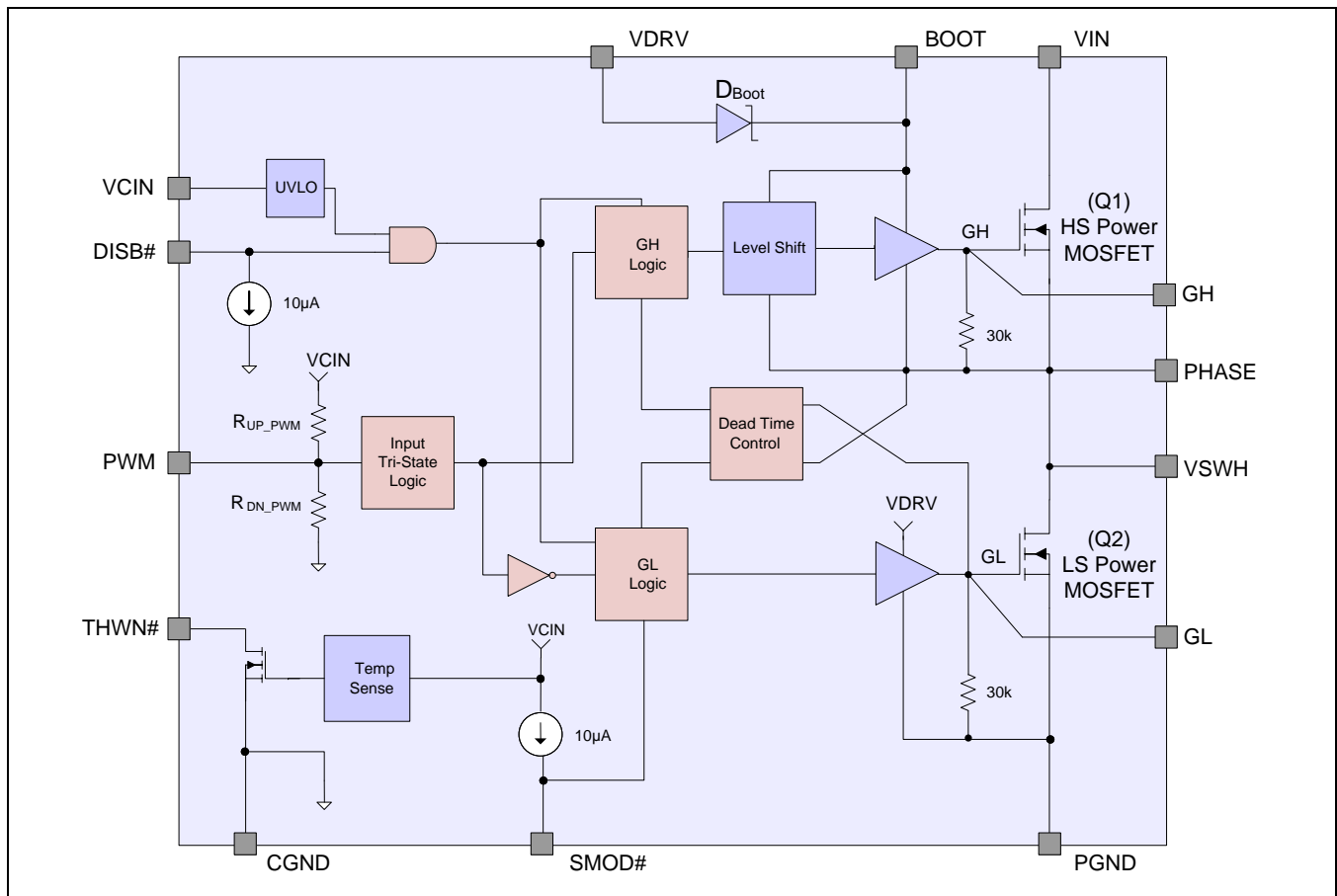



Figure 2.2 ZSPM9010 Block Diagram



2.1. VDRV and Disable (DISB#)

The VCIN pin is monitored by an under-voltage lockout (UVLO) circuit. When V_{CIN} rises above $\sim 3.1V$, the driver is enabled. When V_{CIN} falls below $\sim 2.7V$, the driver is disabled ($GH, GL = 0$; see Figure 2.2 and section 4.2). The driver can also be disabled by pulling the DISB# pin LOW ($DISB\# < V_{IL_DISB}$), which holds both GL and GH LOW regardless of the PWM input state. The driver can be enabled by raising the DISB# pin voltage HIGH ($DISB\# > V_{IH_DISB}$).



Table 2.1 UVLO and Disable Logic

Note: DISB# internal pull-down current source is 10µA (typical).

UVLO	DISB#	Driver State
0	X	Disabled (GH=0, GL=0)
1	0	Disabled (GH=0, GL=0)
1	1	Enabled (see Table 2.2)
1	Open	Disabled (GH=0, GL=0)

2.2. Thermal Warning Flag (THWN#)

The ZSPM9010 provides a thermal warning flag (THWN#) to indicate over-temperature conditions. The thermal warning flag uses an open-drain output that pulls to CGND when the activation temperature (150°C) is reached. The THWN# output returns to the high-impedance state once the temperature falls to the reset temperature (135°C). For use, the THWN# output requires a pull-up resistor, which can be connected to VCIN. Note that THWN# does NOT disable the DrMOS module.

Figure 2.3 Thermal Warning Flag (THWN) Operation

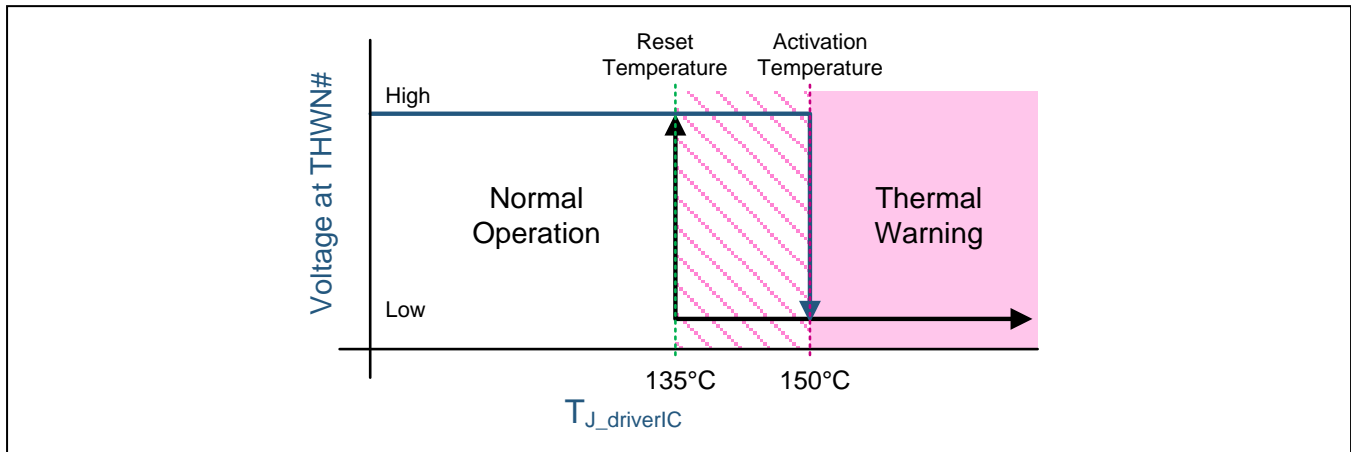

2.3. Tri-State PWM Input

The ZSPM9010 incorporates a tri-state 3.3V PWM input gate drive design. The tri-state gate drive has both logic HIGH level and LOW level, along with a tri-state shutdown voltage window. When the PWM input signal enters and remains within the tri-state voltage window for a defined hold-off time ($t_{D_HOLD-OFF}$), both GL and GH are pulled LOW. This feature enables the gate drive to shut down both high and low side MOSFETs using only one control signal. For example, this can be used for phase shedding in multi-phase voltage regulators.

When exiting a valid tri-state condition, the ZSPM9010 follows the PWM input command. If the PWM input goes from tri-state to LOW, the low-side MOSFET is turned on. If the PWM input goes from tri-state to HIGH, the high-side MOSFET is turned on, as illustrated in Figure 2.4. The ZSPM9010's design allows for short propagation delays when exiting the tri-state window (see section 1.3).

ZSPM9010

Ultra-Compact, High-Performance, High-Frequency DrMOS



Figure 2.4 PWM and Tri-State Timing Diagram

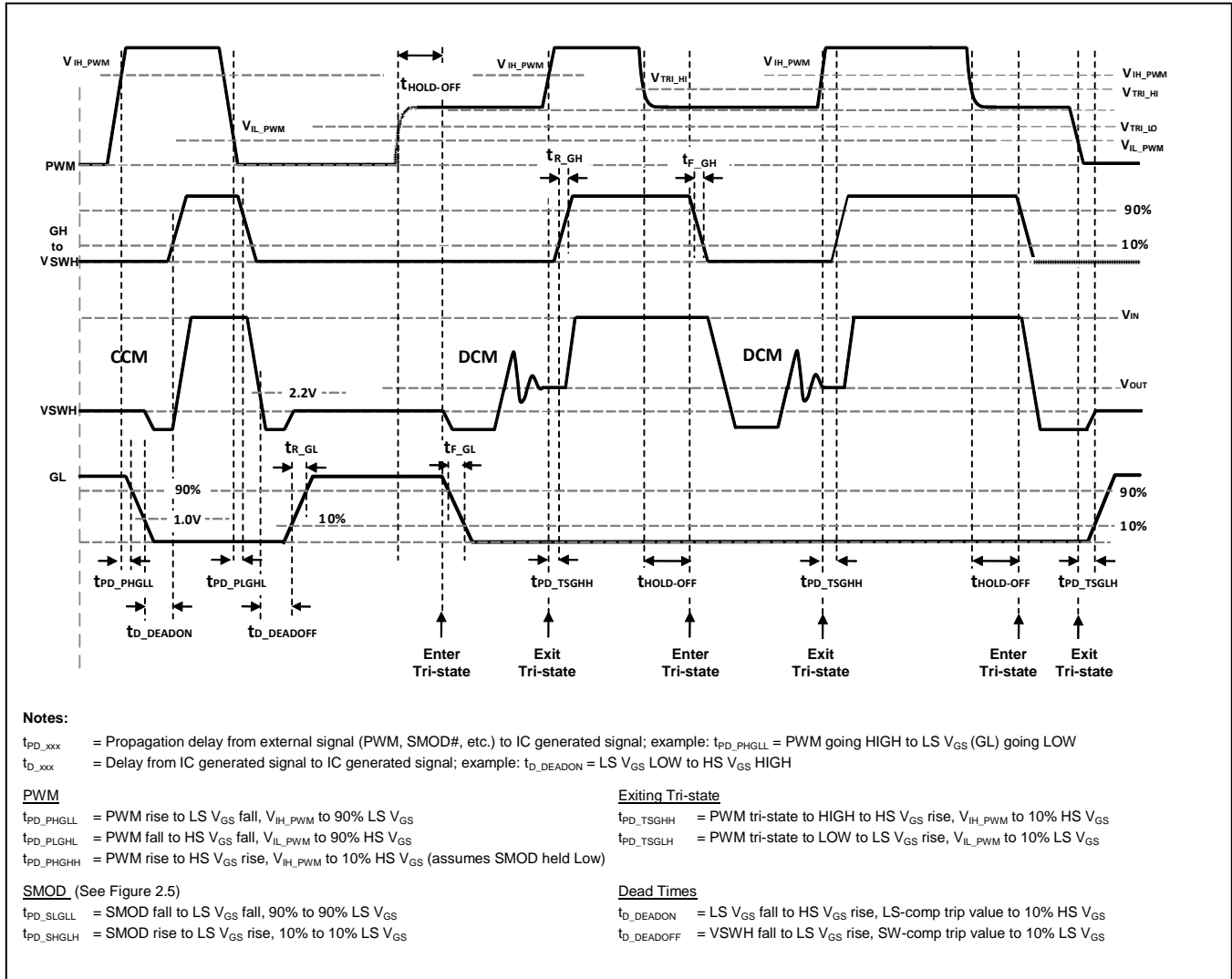



2.4. Adaptive Gate Drive Circuit

The low-side driver (GL) is designed to drive a ground-referenced low $R_{DS(ON)}$ N-channel MOSFET. The bias for GL is internally connected between VDRV and CGND. When the driver is enabled, the driver's output is 180° out of phase with the PWM input. When the driver is disabled (DISB#=0V), GL is held LOW.

The high-side driver is designed to drive a floating N-channel MOSFET. The bias voltage for the high-side driver is developed by a bootstrap supply circuit consisting of the internal Schottky diode and external bootstrap capacitor (C_{BOOT}). During startup, the VSWH pin is held at PGND, allowing C_{BOOT} (see section 3.2) to charge to V_{DRV} through the internal diode. When the PWM input goes HIGH, GH begins to charge the gate of Q1, the high-side MOSFET. During this transition, the charge is removed from C_{BOOT} and delivered to the gate of Q1. As Q1 turns on, V_{SWH} rises to V_{IN} , forcing the BOOT pin to $V_{IN} + V_{BOOT}$, which provides sufficient V_{GS} enhancement for Q1.

To complete the switching cycle, Q1 is turned off by pulling GH to V_{SWH} . C_{BOOT} is then recharged to V_{DRV} when V_{SWH} falls to PGND. The GH output is in-phase with the PWM input. The high-side gate is held LOW when the driver is disabled or the PWM signal is held within the tri-state window for longer than the tri-state hold-off time, $t_{D_HOLD-OFF}$.

The driver IC design ensures minimum MOSFET dead time while eliminating potential shoot-through (cross-conduction) currents. It senses the state of the MOSFETs and adjusts the gate drive adaptively to prevent simultaneous conduction. Figure 2.4 provides the relevant timing waveforms. To prevent overlap during the LOW-to-HIGH switching transition (Q2 off to Q1 on), the adaptive circuitry monitors the voltage at the GL pin. When the PWM signal goes HIGH, Q2 begins to turn off after a propagation delay (t_{PD_PHGLL}). Once the GL pin is discharged below $\sim 1V$, Q1 begins to turn on after adaptive delay t_{D_DEADON} .

To prevent overlap during the HIGH-to-LOW transition (Q1 off to Q2 on), the adaptive circuitry monitors the voltage at the VSWH pin. When the PWM signal goes LOW, Q1 begins to turn off after a propagation delay (t_{PD_PLGHL}). Once the VSWH pin falls below approx. 2.2V, Q2 begins to turn on after adaptive delay $t_{D_DEADOFF}$. $V_{GS(Q1)}$ is also monitored. When $V_{GS(Q1)}$ is discharged below approx. 1.2V, a secondary adaptive delay is initiated that results in Q2 being driven on after $t_{D_TIMEOUT}$, regardless of VSWH state. This function is implemented to ensure C_{BOOT} is recharged each switching cycle in the event that the VSWH voltage does not fall below the 2.2V adaptive threshold. Secondary delay $t_{D_TIMEOUT}$ is longer than $t_{D_DEADOFF}$.

2.5. Skip Mode (SMOD#)

The SMOD function allows higher converter efficiency under light-load conditions. During SMOD, the low-side FET gate signal is disabled (held LOW), preventing discharging of the output capacitors as the filter inductor current attempts reverse current flow – also known as Diode Emulation Mode.

When the SMOD# pin is pulled HIGH, the synchronous buck converter works in Synchronous Mode. This mode allows gating on the low-side FET. When the SMOD# pin is pulled LOW, the low-side FET is gated off. See the timing diagram in Figure 2.5. If the SMOD# pin is connected to the PWM controller, the controller can actively enable or disable SMOD when the controller detects light-load operation.

ZSPM9010

Ultra-Compact, High-Performance, High-Frequency DrMOS



The Analog Mixed Signal Company



Table 2.2 SMOD# Logic

Note: The SMOD feature is intended to have a low propagation delay between the SMOD signal and the low-side FET V_{GS} response time to control diode emulation on a cycle-by-cycle basis.

DISB#	PWM	SMOD#	GH	GL
0	X	X	0	0
1	Tri-State	X	0	0
1	0	0	0	0
1	1	0	1	0
1	0	1	0	1
1	1	1	1	0

Figure 2.5 SMOD# Timing Diagram

See Figure 2.4 for the definitions of the timing parameters.

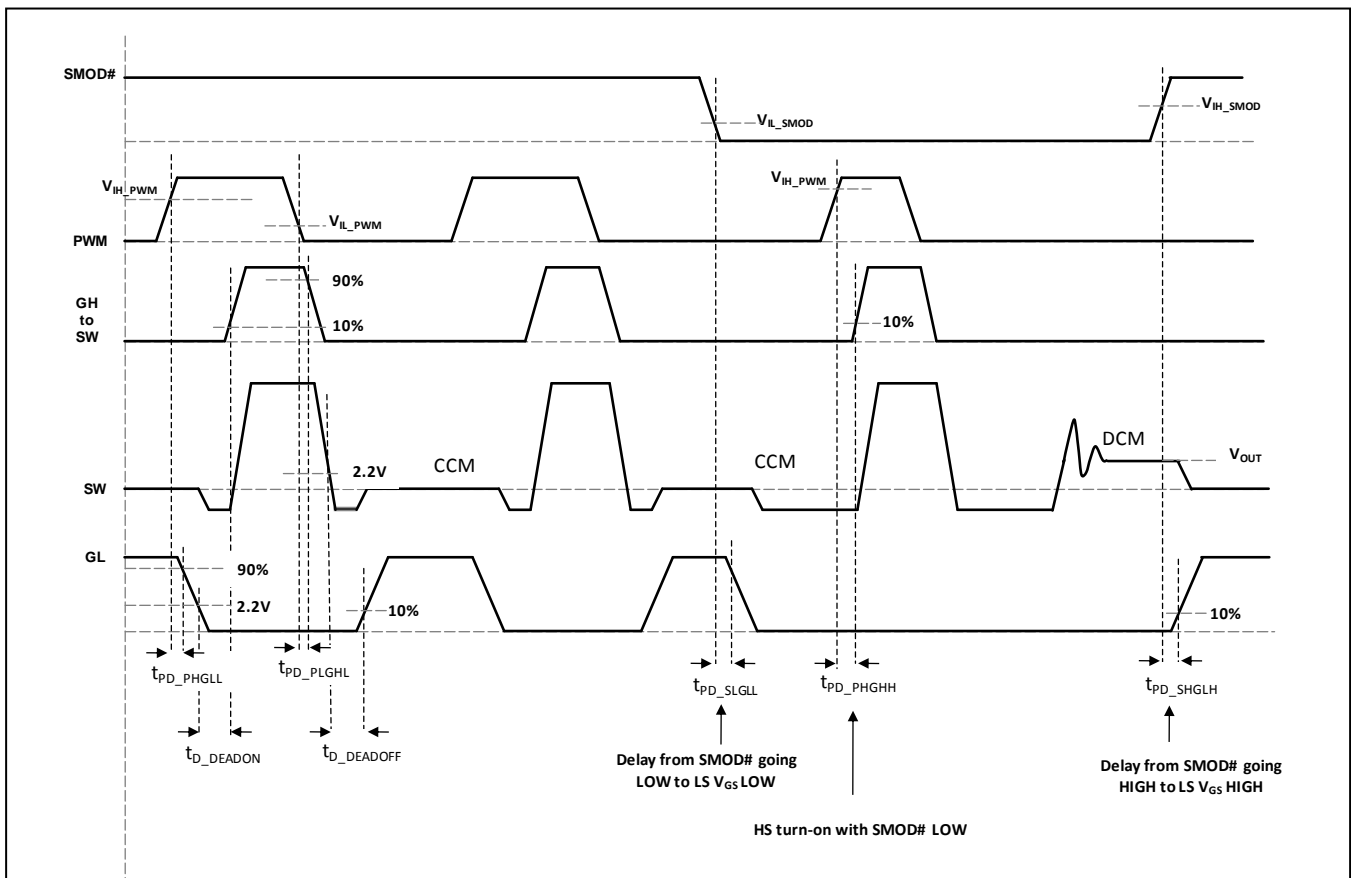

ZSPM9010

Ultra-Compact, High-Performance, High-Frequency DrMOS



The Analog Mixed Signal Company



2.6. PWM

Figure 2.6 PWM Timing

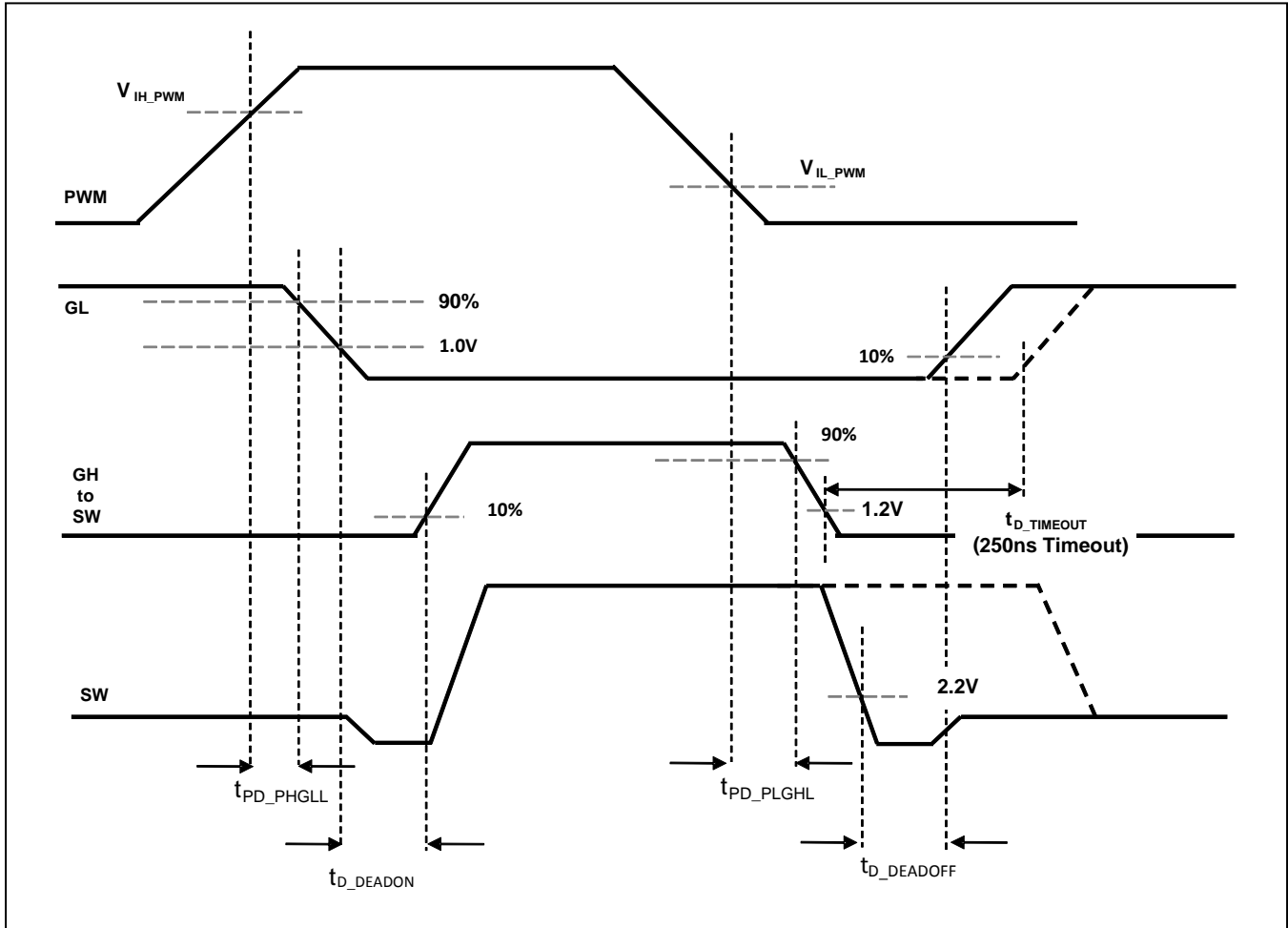



3 Application Design

3.1. Supply Capacitor Selection

For the supply inputs (VDRV and VCIN), a local ceramic bypass capacitor is required to reduce noise and is used to supply the peak transient currents during gate drive switching action. Recommendation: use at least a 1µF capacitor with an X7R or X5R dielectric. Keep this capacitor close to the VCIN and VDRV pins and connect it to the CGND ground plane with vias.

3.2. Bootstrap Circuit

The bootstrap circuit uses a charge storage capacitor (C_{BOOT}), as shown in Figure 3.1. A bootstrap capacitance of 100nF X7R or X5R capacitor is typically adequate. A series bootstrap resistor may be needed for specific applications to improve switching noise immunity. The boot resistor may be required when operating near the maximum rated V_{IN} and is effective at controlling the high-side MOSFET turn-on slew rate and V_{SWH} overshoot. Typical R_{BOOT} values from 0.5Ω to 2.0Ω are effective in reducing V_{SWH} overshoot.

3.3. VCIN Filter

The VDRV pin provides power to the gate drive of the high-side and low-side power MOSFETs. In most cases, VDRV can be connected directly to VCIN, which supplies power to the logic circuitry of the gate driver. For additional noise immunity, an RC filter can be inserted between VDRV and VCIN. Recommendation: use a 10Ω resistor (R_{VCIN}) between VDRV and VCIN and a 1µF capacitor (C_{VCIN}) from VCIN to CGND (see Figure 3.2).

Figure 3.1 Power Loss Measurement Block Diagram

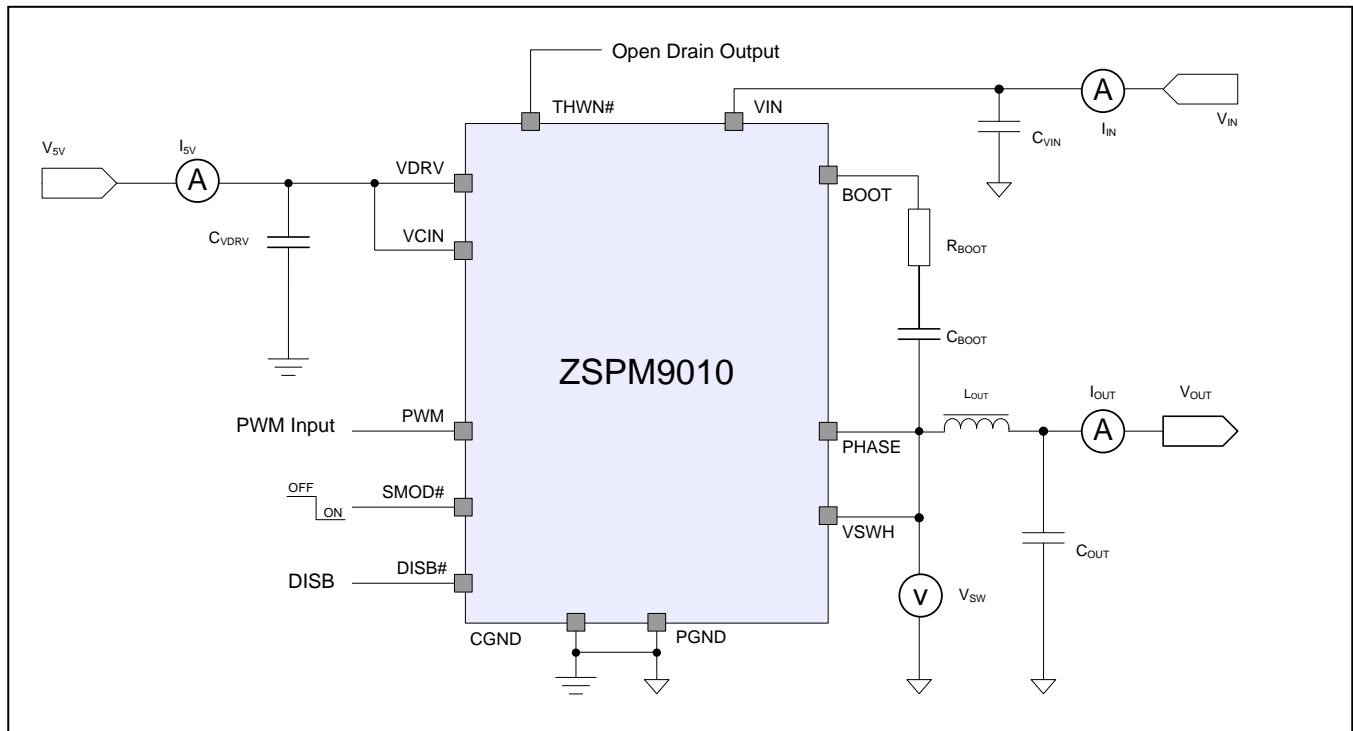

ZSPM9010

Ultra-Compact, High-Performance, High-Frequency DrMOS



Figure 3.2 V_{CIN} Filter Block Diagram

Note: Blue lines indicate the optional recommended filter.

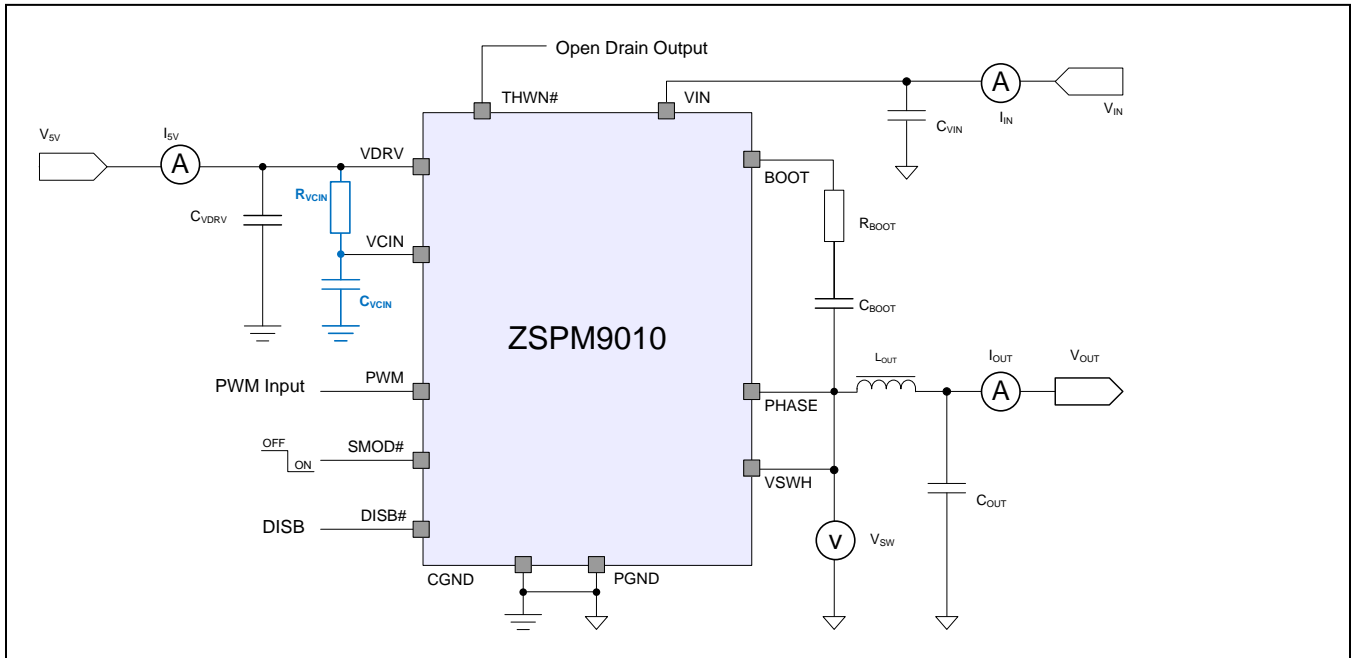

3.4. Power Loss and Efficiency Testing Procedures

The circuit in Figure 3.1 has been used to measure power losses. The efficiency has been calculated based on the equations below.

Power loss calculations:

ZSPM9010

Ultra-Compact, High-Performance, High-Frequency DrMOS

ZMDI[®]

The Analog Mixed Signal Company



$$P_{IN} = (V_{IN} * I_{IN}) + (V_{5V} * I_{5V}) \quad (1)$$

$$P_{SW} = (V_{SW} * I_{OUT}) \quad (2)$$

$$P_{OUT} = (V_{OUT} * I_{OUT}) \quad (3)$$

$$P_{LOSS_MODULE} = (P_{IN} - P_{SW}) \quad (4)$$

$$P_{LOSS_BOARD} = (P_{IN} - P_{OUT}) \quad (5)$$

Efficiency calculations:

$$EFF_{MODULE} = \left(100 * \frac{P_{SW}}{P_{IN}} \right) \% \quad (6)$$

$$EFF_{BOARD} = \left(100 * \frac{P_{OUT}}{P_{IN}} \right) \% \quad (7)$$

ZSPM9010

Ultra-Compact, High-Performance, High-Frequency DrMOS



The Analog Mixed Signal Company



4 Pin Configuration and Package

4.1. Available Packages

The ZSPM9010 is available in a 40-lead clip-bond PQFN package. The pin-out is shown in Figure 4.1. See Figure 4.2 for the mechanical drawing of the package.

Figure 4.1 Pin-out PQFN40 Package

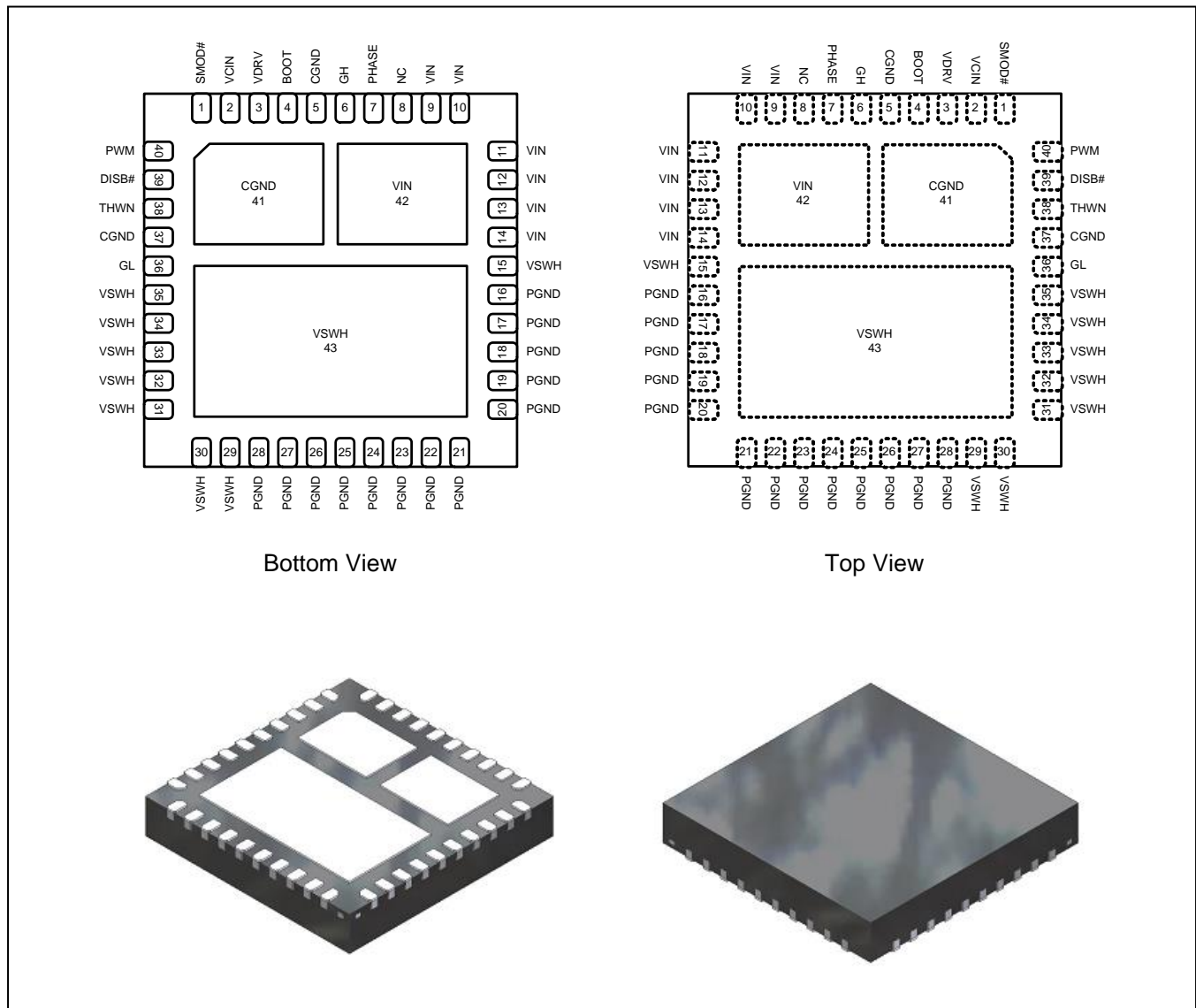



4.2. Pin Description

Pin	Name	Description
1	SMOD#	When SMOD#=HIGH, the low-side driver is the inverse of PWM input. When SMOD#=LOW, the low-side driver is disabled. This pin has a 10 μ A internal pull-up current source. Do not add a noise filter capacitor.
2	VCIN	IC bias supply. A 1 μ F (minimum) ceramic capacitor is recommended from this pin to CGND.
3	VDRV	Power for gate driver. A 1 μ F (minimum) X5R/X7R ceramic capacitor from this pin to CGND is recommended. Place it as close as possible to this pin.
4	BOOT	Bootstrap supply input. Provides voltage supply to the high-side MOSFET driver. Connect a bootstrap capacitor from this pin to PHASE.
5, 37, 41	CGND	IC ground. Ground return for driver IC.
6	GH	Gate high. For manufacturing test only. This pin must float: it must not be connected.
7	PHASE	Switch node pin for bootstrap capacitor routing; electrically shorted to VSWH pin.
8	NC	No connection. The pin is not electrically connected internally but can be connected to VIN for convenience.
9 - 14, 42	VIN	Input power voltage (output stage supply voltage).
15, 29 - 35, 43	VSWH	Switch node. Provides return for high-side bootstrapped driver and acts as a sense point for the adaptive shoot-through protection.
16 - 28	PGND	Power ground (output stage ground). Source pin of the low-side MOSFET.
36	GL	Gate low. For manufacturing test only. This pin must float. It must not be connected.
38	THWN#	Thermal warning flag, open collector output. When temperature exceeds the trip limit, the output is pulled LOW. THWN# does not disable the module.
39	DISB#	Output disable. When LOW, this pin disables the power MOSFET switching (GH and GL are held LOW). This pin has a 10 μ A internal pull-down current source. Do not add a noise filter capacitor.
40	PWM	PWM signal input. This pin accepts a tri-state 3.3V PWM signal from the controller.

ZSPM9010

Ultra-Compact, High-Performance, High-Frequency DrMOS



The Analog Mixed Signal Company



4.3. Package Dimensions

Figure 4.2 PQFN40 Physical Dimensions and Recommended Footprint

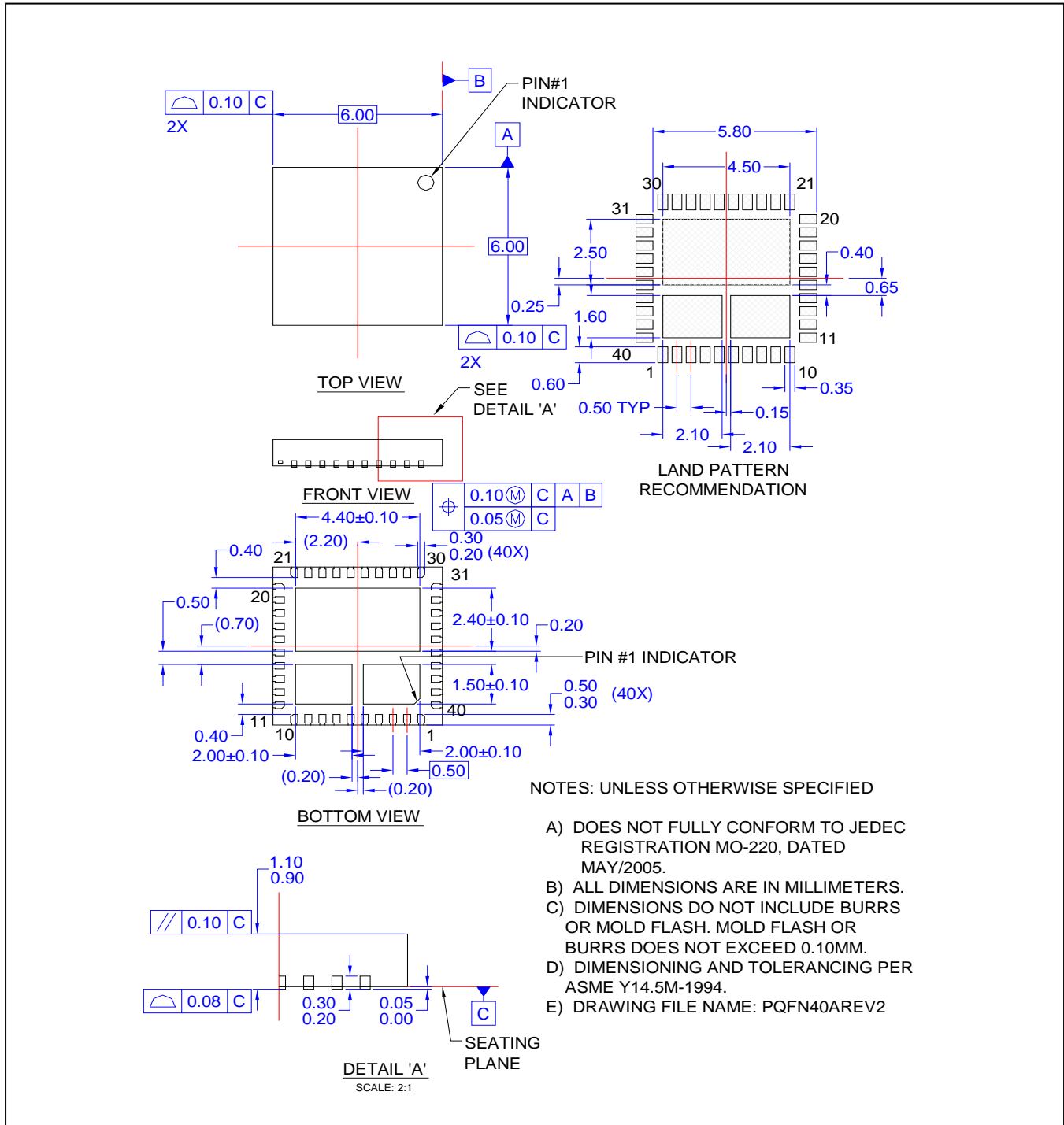



5 Circuit Board Layout Considerations

Figure 5.1 provides an example of a proper layout for the ZSPM9010 and critical components. All of the high-current paths, such as the V_{IN} , V_{SWH} , V_{OUT} , and GND copper traces, should be short and wide for low inductance and resistance. This technique achieves a more stable and evenly distributed current flow, along with enhanced heat radiation and system performance.

The following guidelines are recommendations for the printed circuit board (PCB) designer:

1. Input ceramic bypass capacitors must be placed close to the VIN and PGND pins. This helps reduce the high-current power loop inductance and the input current ripple induced by the power MOSFET switching operation.
2. The V_{SWH} copper trace serves two purposes. In addition to being the high-frequency current path from the DrMOS package to the output inductor, it also serves as a heat sink for the low-side MOSFET in the DrMOS package. The trace should be short and wide enough to present a low-impedance path for the high-frequency, high-current flow between the DrMOS and inductor to minimize losses and temperature rise. Note that the VSWH node is a high-voltage and high-frequency switching node with a high noise potential. Care should be taken to minimize coupling to adjacent traces. Since this copper trace also acts as a heat sink for the lower FET, the designer must balance using the largest area possible to improve DrMOS cooling with maintaining acceptable noise emission.
3. Locate the output inductor close to the ZSPM9010 to minimize the power loss due to the VSWH copper trace. Care should also be taken so the inductor dissipation does not heat the DrMOS.
4. The power MOSFETs used in the output stage are effective for minimizing ringing due to fast switching. In most cases, no VSWH snubber is required. If a snubber is used, it should be placed close to the VSWH and PGND pins. The resistor and capacitor must be the proper size for the power dissipation.
5. VCIN, VDRV, and BOOT capacitors should be placed as close as possible to the respective pins to ensure clean and stable power. Routing width and length should be considered as well.
6. Include a trace from PHASE to VSWH to improve the noise margin. Keep the trace as short as possible.
7. The layout should include a placeholder to insert a small-value series boot resistor (R_{BOOT}) between the boot capacitor (C_{BOOT}) and DrMOS BOOT pin. The BOOT-to-VSWH loop size, including R_{BOOT} and C_{BOOT} , should be as small as possible. The boot resistor may be required when operating near the maximum rated V_{IN} . The boot resistor is effective for controlling the high-side MOSFET turn-on slew rate and VSWH overshoot. R_{BOOT} can improve the noise operating margin in synchronous buck designs that might have noise issues due to ground bounce or high positive and negative VSWH ringing. However, inserting a boot resistance lowers the DrMOS efficiency. Efficiency versus noise trade-offs must be considered. R_{BOOT} values from 0.5 Ω to 2.0 Ω are typically effective in reducing VSWH overshoot.
8. The VIN and PGND pins handle large current transients with frequency components greater than 100MHz. If possible, these pins should be connected directly to the VIN and board GND planes. Important: the use of thermal relief traces in series with these pins is discouraged since this adds inductance to the power path. Added inductance in series with the VIN or PGND pin degrades system noise immunity by increasing positive and negative VSWH ringing.
9. Connect the CGND pad and PGND pins to the GND plane copper with multiple vias for stable grounding. Poor grounding can create a noise transient offset voltage level between CGND and PGND. This could lead to faulty operation of the gate driver and MOSFETs.

ZSPM9010

Ultra-Compact, High-Performance, High-Frequency DrMOS



10. Ringing at the BOOT pin is most effectively controlled by close placement of the boot capacitor. Do not add a capacitor from BOOT to ground; this may lead to excess current flow through the BOOT diode.
11. The SMOD# and DISB# pins have weak internal pull-up and pull-down current sources, respectively. Do NOT float these pins if avoidable. These pins should not have any noise filter capacitors.
12. Use multiple vias on each copper area to interconnect top, inner, and bottom layers to help distribute current flow and heat conduction. Vias should be relatively large and of reasonably low inductance. Critical high-frequency components, such as R_{BOOT} , C_{BOOT} , the RC snubber, and the bypass capacitors should be located as close to the respective DrMOS module pins as possible on the top layer of the PCB. If this is not feasible, they should be connected from the backside through a network of low-inductance vias.

Figure 5.1 PCB Layout Example

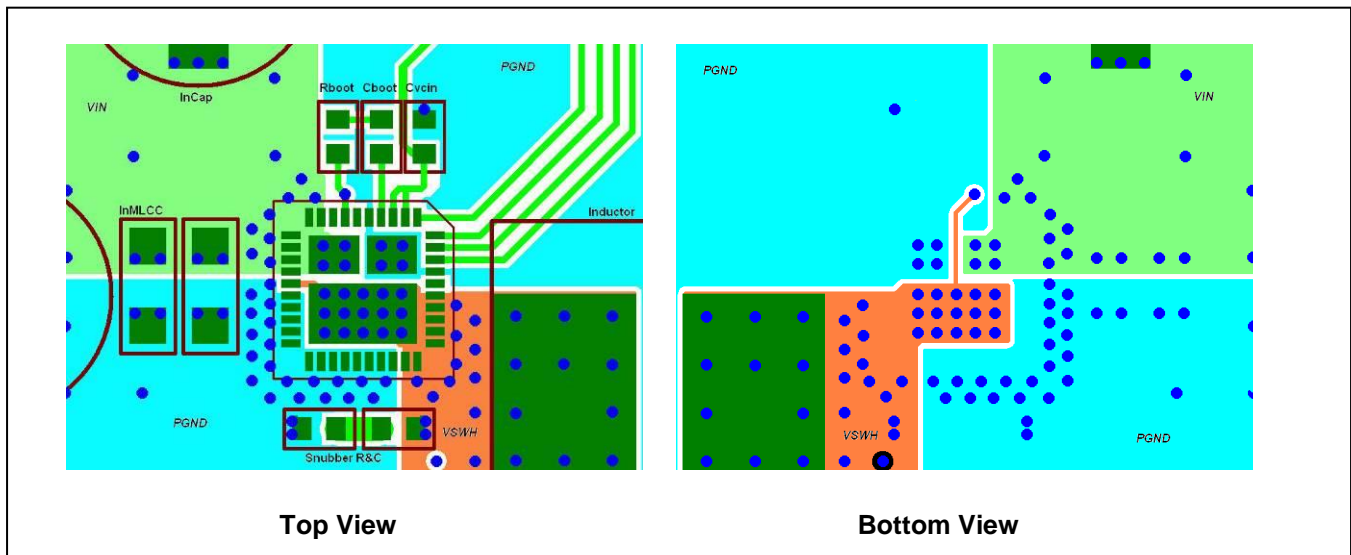

6 Ordering Information

Product Sales Code	Description	Package
ZSPM9010ZA1R	ZSPM9010 Lead-Free PQFN40 — Temperature range: -40°C to +125°C	Reel
ZSPM8010-KIT	Open-Loop Evaluation Board for ZSPM9010	Kit

ZSPM9010

Ultra-Compact, High-Performance, High-Frequency DrMOS



The Analog Mixed Signal Company



7 Related Documents

Document	File Name
ZSPM8010-KIT User Guide	ZSPM8010-KIT_for_ZSPM9010_Rev_X_xy

Visit ZMDI's website www.zmdi.com or contact your nearest sales office for the latest version of these documents.

8 Document Revision History

Revision	Date	Description
1.00	February 6, 2012	First release
1.01	March 20, 2012	Update to timing diagram Figure 2.4. Update to block diagram. Minor edits to application illustration on page 2. Update for ZMDI contacts.
1.02	August 20, 2012	Update of available support. Update of ordering information. Update of related documents.
1.03	November 19, 2012	Minor edits and update for contact information.
1.04	March 8, 2013	Minor updates for cover and header imagery and contact information.

Sales and Further Information		www.zmdi.com	SPM@zmdi.com
Zentrum Mikroelektronik Dresden AG Global Headquarters Grenzstrasse 28 01109 Dresden, Germany Central Office: Phone +49.351.8822.306 Fax +49.351.8822.337	ZMD America, Inc. 1525 McCarthy Blvd., #212 Milpitas, CA 95035-7453 USA USA Phone 1.855.275.9634 Phone +1.408.883.6310 Fax +1.408.883.6358	Zentrum Mikroelektronik Dresden AG, Japan Office 2nd Floor, Shinbashi Tokyu Bldg. 4-21-3, Shinbashi, Minato-ku Tokyo, 105-0004 Japan Phone +81.3.6895.7410 Fax +81.3.6895.7301	ZMD FAR EAST, Ltd. 3F, No. 51, Sec. 2, Keelung Road 11052 Taipei Taiwan Phone +886.2.2377.8189 Fax +886.2.2377.8199
Zentrum Mikroelektronik Dresden AG, Korea Office U-space 1 Building 11th Floor, Unit JA-1102 670 Sampyeong-dong Bundang-gu, Seongnam-si Gyeonggi-do, 463-400 Korea Phone +82.31.950.7679 Fax +82.504.841.3026	European Technical Support Phone +49.351.8822.7.772 Fax +49.351.8822.87.772		
European Sales (Stuttgart) Phone +49.711.674517.55 Fax +49.711.674517.87955	DISCLAIMER: This information applies to a product under development. Its characteristics and specifications are subject to change without notice. Zentrum Mikroelektronik Dresden AG (ZMD AG) assumes no obligation regarding future manufacture unless otherwise agreed to in writing. The information furnished hereby is believed to be true and accurate. However, under no circumstances shall ZMD AG be liable to any customer, licensee, or any other third party for any special, indirect, incidental, or consequential damages of any kind or nature whatsoever arising out of or in any way related to the furnishing, performance, or use of this technical data. ZMD AG hereby expressly disclaims any liability of ZMD AG to any customer, licensee or any other third party, and any such customer, licensee and any other third party hereby waives any liability of ZMD AG for any damages in connection with or arising out of the furnishing, performance or use of this technical data, whether based on contract, warranty, tort (including negligence), strict liability, or otherwise.		

Data Sheet March 8, 2013	© 2013 Zentrum Mikroelektronik Dresden AG — Rev.1.04 All rights reserved. The material contained herein may not be reproduced, adapted, merged, translated, stored, or used without the prior written consent of the copyright owner. The information furnished in this publication is subject to changes without notice.	30 of 30
-----------------------------	------------------------------------------------------------------------------------------------------------------------------------------------------------------------------------------------------------------------------------------------------------------------------------------------------------------------------	----------

Компания «Life Electronics» занимается поставками электронных компонентов импортного и отечественного производства от производителей и со складов крупных дистрибьюторов Европы, Америки и Азии.

С конца 2013 года компания активно расширяет линейку поставок компонентов по направлению коаксиальный кабель, кварцевые генераторы и конденсаторы (керамические, пленочные, электролитические), за счёт заключения дистрибьюторских договоров

Мы предлагаем:

- Конкурентоспособные цены и скидки постоянным клиентам.
- Специальные условия для постоянных клиентов.
- Подбор аналогов.
- Поставку компонентов в любых объемах, удовлетворяющих вашим потребностям.
- Приемлемые сроки поставки, возможна ускоренная поставка.
- Доставку товара в любую точку России и стран СНГ.
- Комплексную поставку.
- Работу по проектам и поставку образцов.
- Формирование склада под заказчика.
- Сертификаты соответствия на поставляемую продукцию (по желанию клиента).
- Тестирование поставляемой продукции.
- Поставку компонентов, требующих военную и космическую приемку.
- Входной контроль качества.
- Наличие сертификата ISO.

В составе нашей компании организован Конструкторский отдел, призванный помогать разработчикам, и инженерам.

Конструкторский отдел помогает осуществить:

- Регистрацию проекта у производителя компонентов.
- Техническую поддержку проекта.
- Защиту от снятия компонента с производства.
- Оценку стоимости проекта по компонентам.
- Изготовление тестовой платы монтаж и пусконаладочные работы.



Тел: +7 (812) 336 43 04 (многоканальный)

Email: org@lifeelectronics.ru