

D	PG4/5,modify keepout zone.pg1,2,3/5 add blackhsg p/n	28.Nov.2011
REV NO	DESCRIPTION	DATE

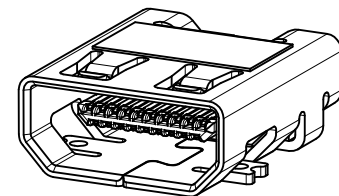

MICRO HDMI-SMT TYPE MOUNTING
ISOMETRIC VIEW

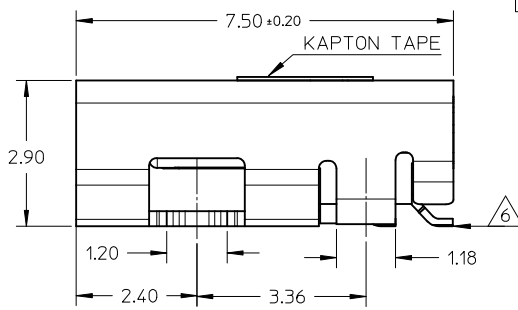
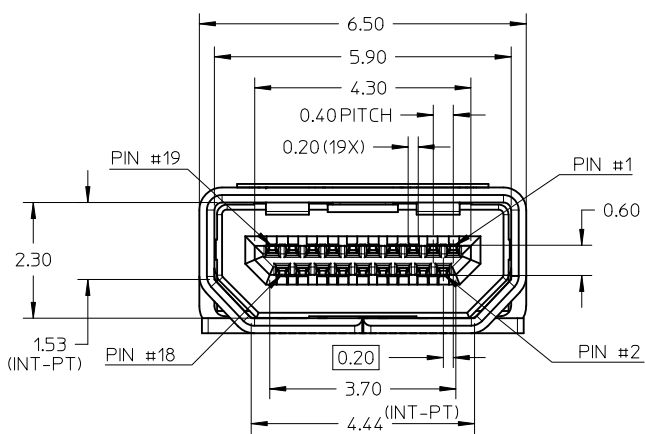
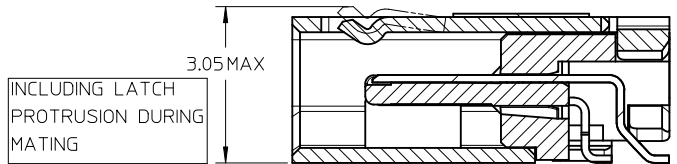
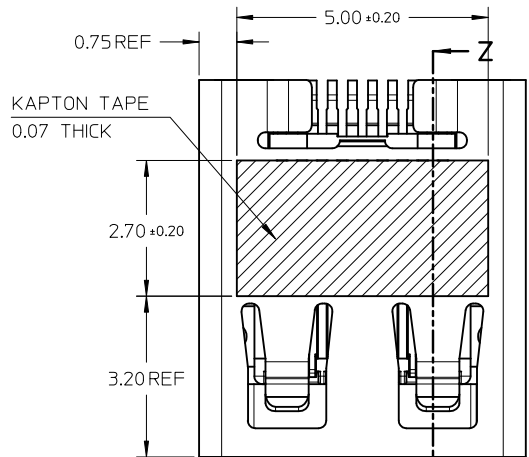
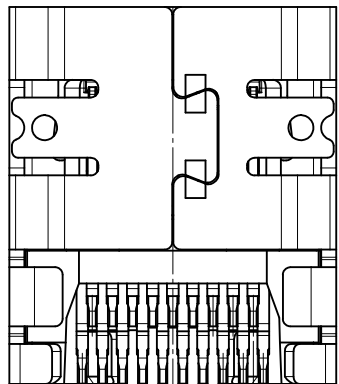

SECTION Z-Z

SELECTIVE GOLD FLASH
ON SOLDERING FACE ONLY

- NOTES:
- MATERIALS:
HOUSING: LCP, 30% GLASS FILLED, UL94V-0
TERMINALS: COPPER ALLOY
SHIELD: STAINLESS STEEL
 - FINISHES:
TERMINALS: GOLD ON CONTACT AREA (Refer Table),
0.05UM MIN GOLD FLASH ON SOLDER TAILS,
AND 2.0UM MIN NICKEL UNDERPLATE OVERALL
SHIELD: MATTE TIN (Refer Table) OVER 1.27UM MIN NICKEL
 - PRODUCT SPECIFICATION: PS-46765-001
 - PACKAGING SPECIFICATION: PACKED IN TAPE & REEL
 - SEE SHEET 4 OF 5 FOR RECOMMENDED PCB LAYOUT
 - TERMINAL SOLDER-TAIL COPLANARITY 0.08 MAX

DESCRIPTION	Contact: 0.76µM Gold Min Shield: 3.8µM Tin Min PART NUMBER	Contact: 0.38µM Gold Min Shield: 2.0µM Tin Min PART NUMBER
SMT TYPE+KAPTON TAPE	46765-0001	46765-0301
SMT TYPE+BLACK HSG+KAPTON TAPE	--	46765-0302
SMT TYPE	46765-0011	46765-0311
SMT TYPE+BLACK HSG	--	46765-0312

RELEASED	EC NO: S2012-0444	2011/10/24
DRWN: CWANG25	2011/12/02	
CHKD: JKOH	2011/12/02	
APPR: NAGESHKN	2011/12/02	
REV	DESCRIPTION	

QUALITY SYMBOLS	GENERAL TOLERANCES (UNLESS SPECIFIED)
▽=0	mm INCH
∇=0	4 PLACES ± --- ± ---
	3 PLACES ± --- ± ---
	2 PLACES ± 0.1 ± ---
	1 PLACE ± --- ± ---
	ANGULAR ± 2 °
	DRAFT WHERE APPLICABLE MUST REMAIN WITHIN DIMENSIONS

DIMENSION STYLE	SCALE	DESIGN UNITS	THIRD ANGLE PROJECTION
MM ONLY	NTS	METRIC	
DRAWN BY	DATE	TITLE	
MKAMARAU	2008/10/14	MICRO HDMI, TYPE-D 0.4MM PITCH, 19CKT RECEPTACLE CONNECTOR	
CHECKED BY	DATE		
MKAMARAU	2008/10/14		
APPROVED BY	DATE		
NAGESHKN	2010/11/19		
MATERIAL NO.	DOCUMENT NO.		
SEE TABLE	SD-46765-001		
SIZE	THIS DRAWING CONTAINS INFORMATION THAT IS PROPRIETARY TO MOLEX INCORPORATED AND SHOULD NOT BE USED WITHOUT WRITTEN PERMISSION		SHEET NO.
A3			1 OF 5

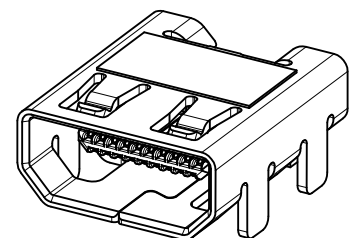
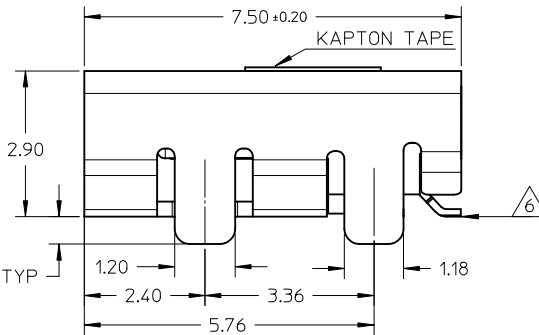
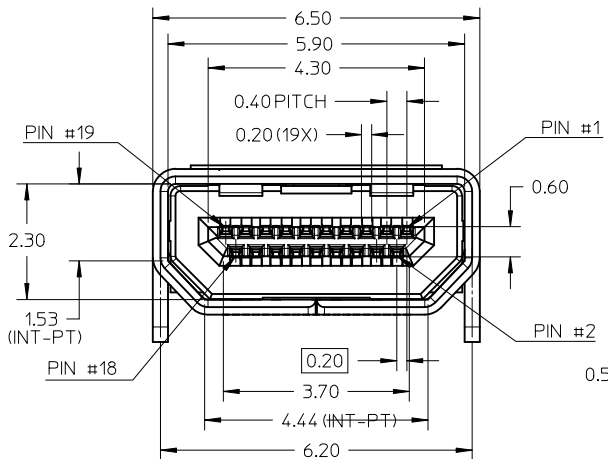

MICRO HDMI-THRU HOLE TYPE MOUNTING ISOMETRIC VIEW

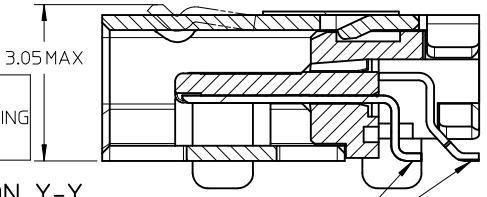

SECTION Y-Y

SELECTIVE GOLD FLASH ON SOLDERING FACE ONLY

NOTES:

1. MATERIALS:
HOUSING: LCP, 30% GLASS FILLED, UL94V-0
TERMINALS: COPPER ALLOY
SHIELD: STAINLESS STEEL
2. FINISHES:
TERMINALS: GOLD ON CONTACT AREA (Refer Table),
0.05UM MIN GOLD FLASH ON SOLDER TAILS,
AND 2.0UM MIN NICKEL UNDERPLATE OVERALL
SHIELD: MATTE TIN (Refer Table) OVER 1.27UM MIN NICKEL
3. PRODUCT SPECIFICATION: PS-46765-001
4. PACKAGING SPECIFICATION: PACKED IN TAPE & REEL
5. SEE SHEET 4 OF 5 FOR RECOMMENDED PCB LAYOUT
6. TERMINAL SOLDER-TAIL COPLANARITY 0.08 MAX

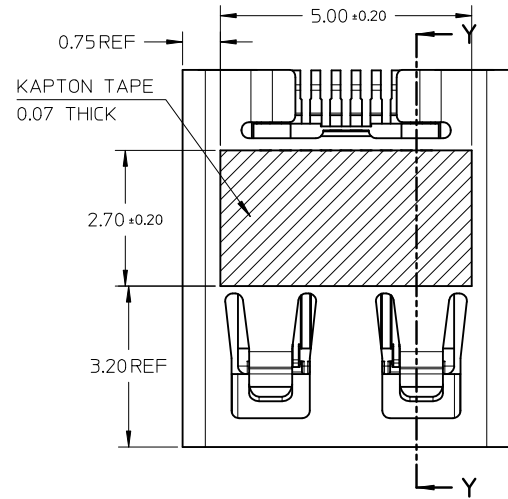
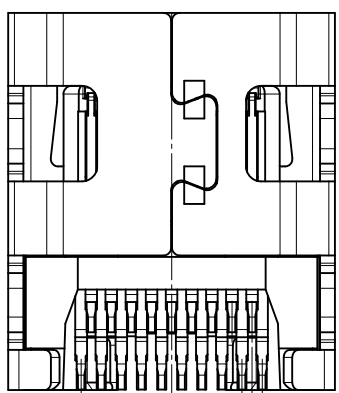

DESCRIPTION	Contact: 0.76µM Gold Min Shield: 3.8µM Tin Min	Contact: 0.38µM Gold Min Shield: 2.0µM Tin Min
THRU HOLE TYPE+KAPTON TAPE	46765-1001	46765-1301
THRU HOLE TYPE+BLACK HSG+KAPTON TAPE	--	46765-1302
THRU HOLE TYPE	46765-1011	46765-1311
THRU HOLE TYPE+BLACK HSG	--	46765-1312

RELEASED
EC NO: S2012-0444
DRWN: CWANG25
CHKD: JKOH
APPR: NAGESHK N
2011/10/24
2011/12/02
2011/12/02

QUALITY SYMBOLS	GENERAL TOLERANCES (UNLESS SPECIFIED)
▽=0	mm INCH
◻=0	4 PLACES ± --- ± ---
	3 PLACES ± --- ± ---
	2 PLACES ± 0.1 ± ---
	1 PLACE ± --- ± ---
	ANGULAR ± 2 °
	DRAFT WHERE APPLICABLE MUST REMAIN WITHIN DIMENSIONS

DIMENSION STYLE		SCALE	DESIGN UNITS	THIRD ANGLE PROJECTION
MM ONLY		NTS	METRIC	⊕
DRAWN BY	DATE	TITLE		
MKAMARAU	2008/10/14	MICRO HDMI, TYPE-D		
CHECKED BY	DATE	0.4MM PITCH, 19CKT		
MKAMARAU	2008/10/14	RECEPTACLE CONNECTOR		
APPROVED BY	DATE	MOLEX INCORPORATED		
NAGESHK N	2010/11/19	MOLEX INCORPORATED		
MATERIAL NO.	DOCUMENT NO.	SD-46765-001		
SEE TABLE		SHEET NO. 2 OF 5		

DRAWN BY		DATE	TITLE	
MKAMARAU		2008/10/14	MICRO HDMI, TYPE-D	
CHECKED BY		DATE	0.4MM PITCH, 19CKT	
MKAMARAU		2008/10/14	RECEPTACLE CONNECTOR	
APPROVED BY		DATE	MOLEX INCORPORATED	
NAGESHK N		2010/11/19	MOLEX INCORPORATED	
MATERIAL NO.		DOCUMENT NO.	SD-46765-001	
SEE TABLE				SHEET NO. 2 OF 5

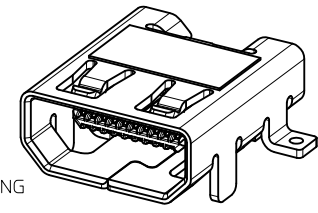

MICRO HDMI
HYBRID TYPE MOUNTING

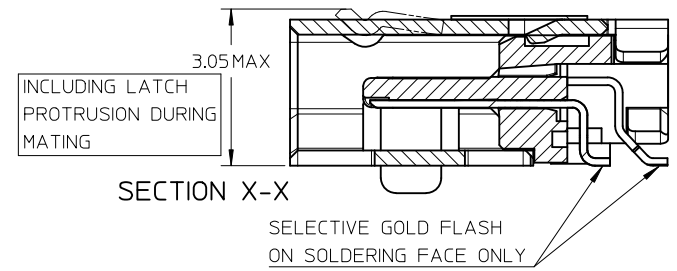
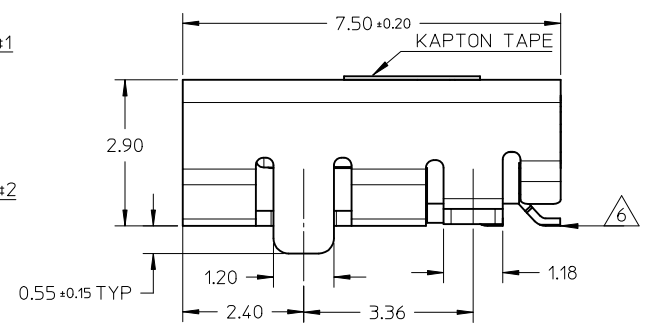
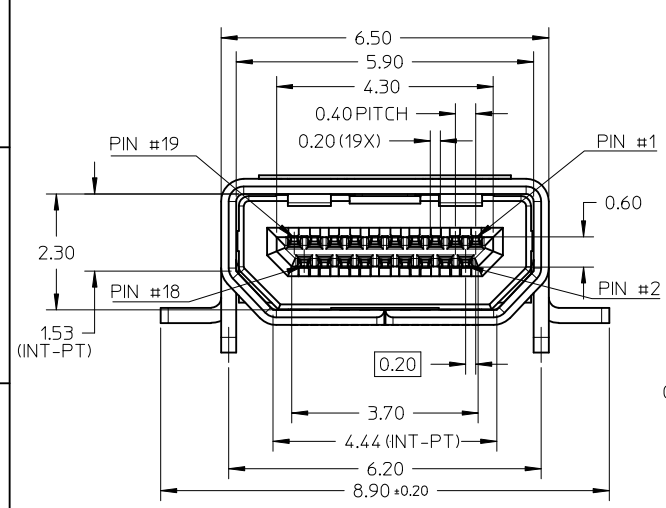

- NOTES:
- MATERIALS:
HOUSING: LCP, 30% GLASS FILLED, UL94V-0
TERMINALS: COPPER ALLOY
SHIELD: STAINLESS STEEL
 - FINISHES:
TERMINALS: GOLD ON CONTACT AREA (Refer Table),
0.05UM MIN GOLD FLASH ON SOLDER TAILS,
AND 2.0UM MIN NICKEL UNDERPLATE OVERALL
SHIELD: MATTE TIN (Refer Table) OVER 1.27UM MIN NICKEL
 - PRODUCT SPECIFICATION: PS-46765-001
 - PACKAGING SPECIFICATION: PACKED IN TAPE & REEL
 - SEE SHEET 4 OF 5 FOR RECOMMENDED PCB LAYOUT
 - TERMINAL SOLDER-TAIL COPLANARITY 0.08 MAX

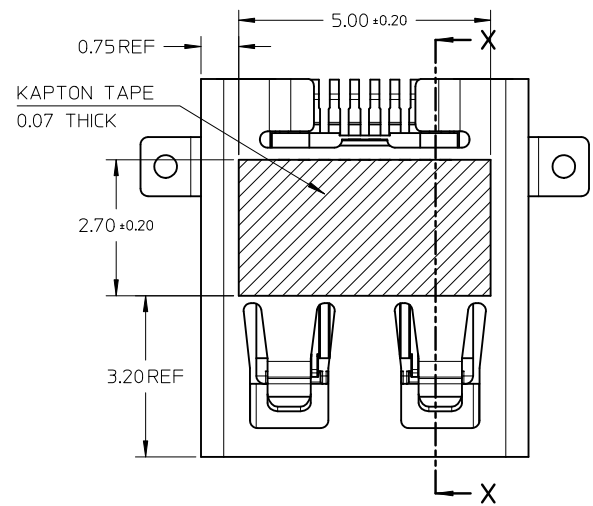
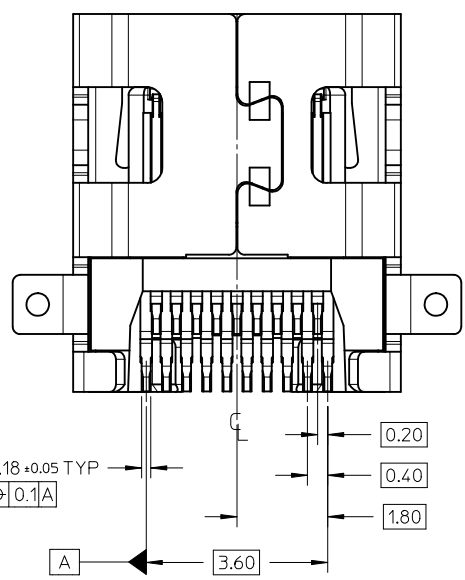

DESCRIPTION	Contact: 0.764M Gold Min Shield: 3.84M Tin Min PART NUMBER	Contact: 0.384M Gold Min Shield: 2.04M Tin Min PART NUMBER
HYBRID TYPE+KAPTON TAPE	46765-2001	46765-2301
HYBRID TYPE+BLACK HOUSING+KAPTON TAPE	46765-2021	46765-2302
HYBRID TYPE	46765-2011	46765-2311
HYBRID TYPE+BLACK HSG	--	46765-2312

RELEASED EC NO: S2012-0444 DRWN: CWANG25 2011/10/24 CHYKDKJKOH 2011/12/02 APPR: NAGESHKIN 2011/12/02	QUALITY SYMBOLS	GENERAL TOLERANCES (UNLESS SPECIFIED)	DIMENSION STYLE	SCALE	DESIGN UNITS	THIRD ANGLE PROJECTION
	▽=0 ◻=0	mm INCH 4 PLACES ± --- ± --- 3 PLACES ± --- ± --- 2 PLACES ± 0.1 ± --- 1 PLACE ± --- ± --- ANGULAR ± 2 °	MM ONLY	NTS	METRIC	
	DESCRIPTION	DRAFT WHERE APPLICABLE MUST REMAIN WITHIN DIMENSIONS	DRAWN BY: MKAMARAU CHECKED BY: MKAMARAU APPROVED BY: NAGESHKIN DATE: 2008/10/14 DATE: 2008/10/14 DATE: 2010/11/19	TITLE	MICRO HDMI, TYPE-D 0.4MM PITCH, 19CKT RECEPTACLE CONNECTOR	
	REV		MATERIAL NO.	SEE TABLE	DOCUMENT NO.	MOLEX INCORPORATED SD-46765-001

THIS DRAWING CONTAINS INFORMATION THAT IS PROPRIETARY TO MOLEX INCORPORATED AND SHOULD NOT BE USED WITHOUT WRITTEN PERMISSION

SIZE: A3

SHEET NO. 3 OF 5

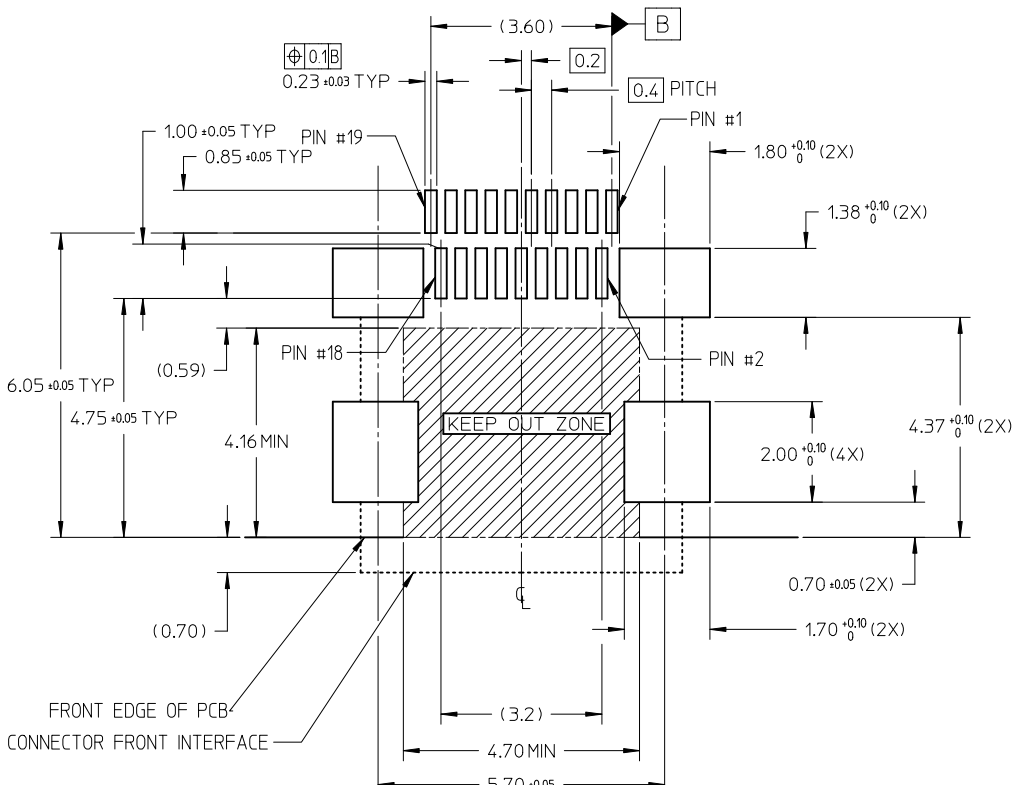

RECOMMENDED PCB LAYOUT
 COMPONENT SIDE OF BOARD
 SHEET 1 OF 5

PIN	SIGNAL ASSIGNMENT
1	Hot Plug Detect
2	Utility
3	TMDS Data2+
4	TMDS Data2- Shield
5	TMDS Data2-
6	TMDS Data1+
7	TMDS Data1- Shield
8	TMDS Data1-
9	TMDS Data0+
10	TMDS Data0- Shield
11	TMDS Data0-
12	TMDS Clock+
13	TMDS Clock- Shield
14	TMDS Clock-
15	CEC
16	DDC/CEC Ground
17	SCL
18	SDA
19	+5V Power

CONNECTION	SIGNALS
	TYPE D CONNECTOR
FIRST MAKE	CONNECTOR SHELL
SECOND MAKE	PINS 1 - 18
THIRD MAKE	PIN 19 (+5V POWER)

RELEASED EC NO: S2012-0444 DRWN: CWANG25 CHKD: KJKOH APPR: NAGESHKN	2011/10/24 2011/12/02 2011/12/02	DESCRIPTION REV	QUALITY SYMBOLS	GENERAL TOLERANCES (UNLESS SPECIFIED)	DIMENSION STYLE	SCALE	DESIGN UNITS	THIRD ANGLE PROJECTION
			$\nabla = 0$ $\square = 0$	mm INCH 4 PLACES ± --- ± --- 3 PLACES ± --- ± --- 2 PLACES ± 0.1 ± --- 1 PLACE ± --- ± --- ANGULAR ± 2 °	MM ONLY	NTS	METRIC	
				DRAFT WHERE APPLICABLE MUST REMAIN WITHIN DIMENSIONS	DRAWN BY: MKAMARAU DATE: 2008/10/14 CHECKED BY: MKAMARAU DATE: 2008/10/14 APPROVED BY: NAGESHKN DATE: 2010/11/19 MATERIAL NO.	TITLE		MICRO HDMI, TYPE-D 0.4MM PITCH, 19CKT RECEPTACLE CONNECTOR
					SEE TABLE THIS DRAWING CONTAINS INFORMATION THAT IS PROPRIETARY TO MOLEX INCORPORATED AND SHOULD NOT BE USED WITHOUT WRITTEN PERMISSION	MOLEX INCORPORATED DOCUMENT NO. SD-46765-001 SHEET NO. 4 OF 5		

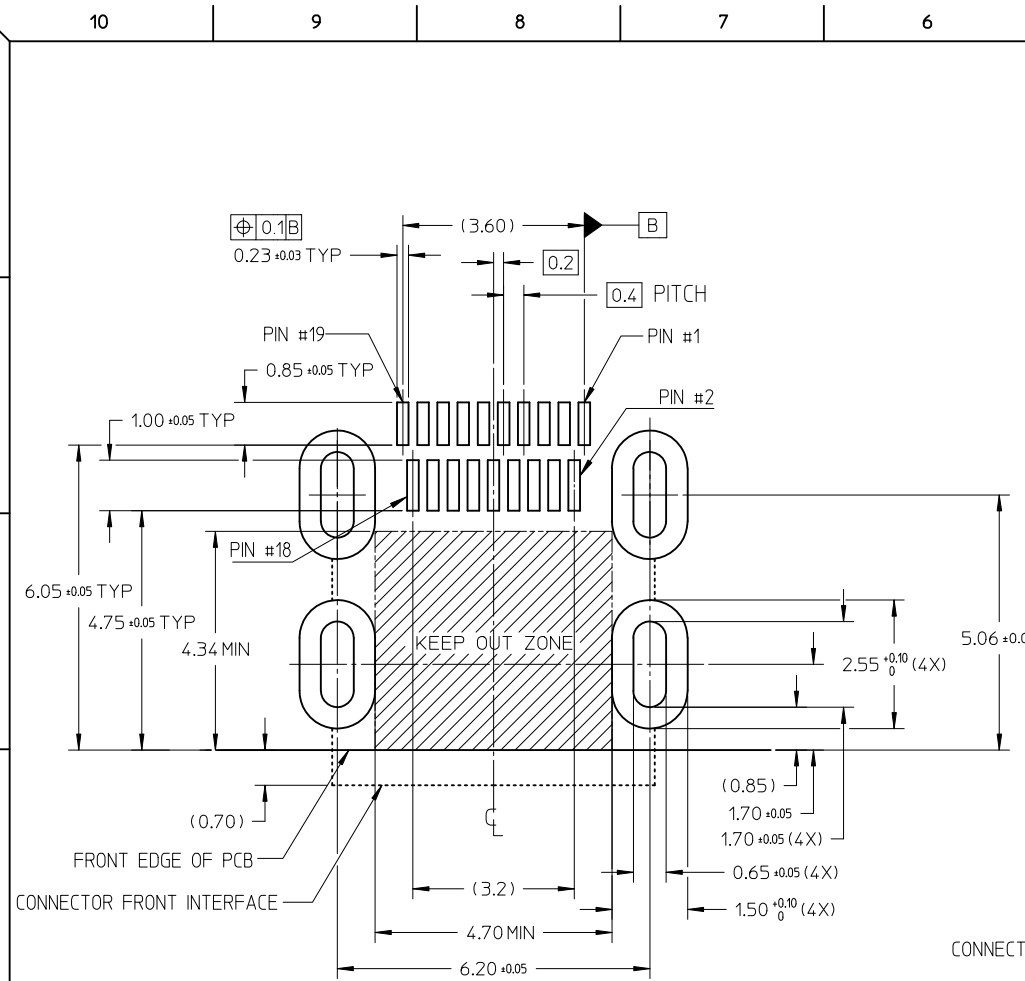

RECOMMENDED PCB LAYOUT
COMPONENT SIDE OF BOARD
SHEET 2 OF 5

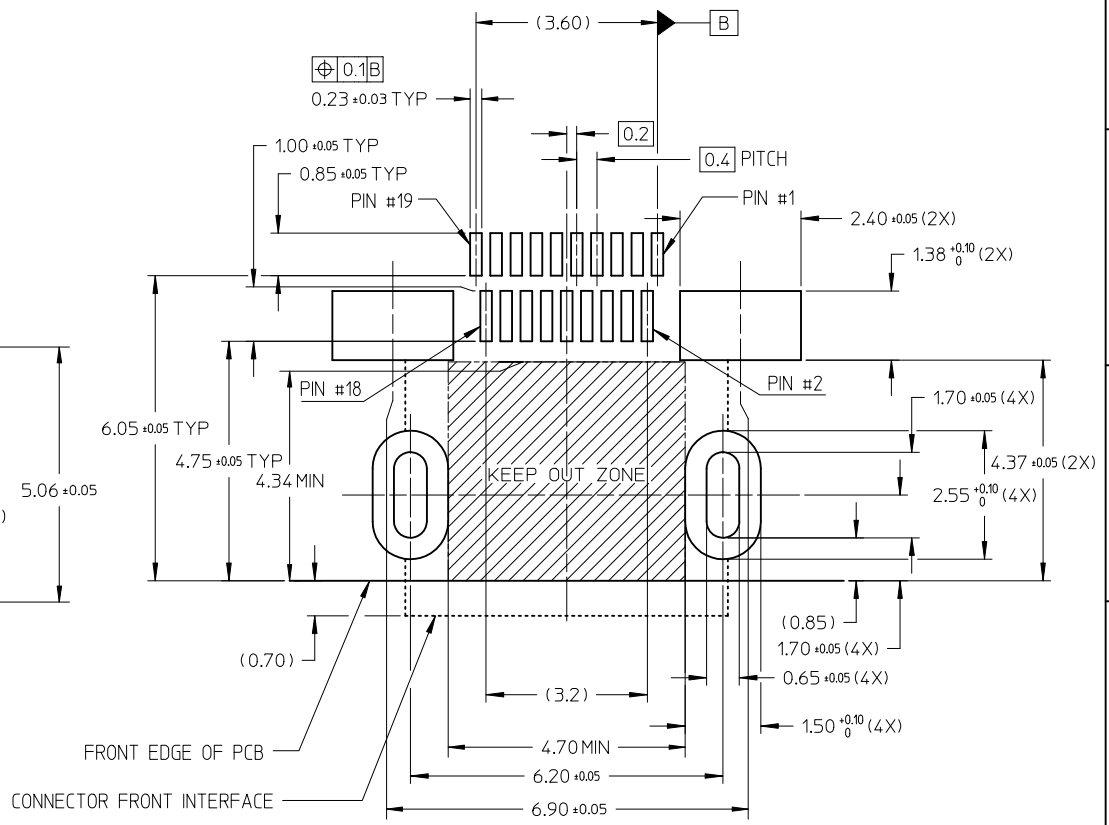

RECOMMENDED PCB LAYOUT
COMPONENT SIDE OF BOARD
SHEET 3 OF 5

RELEASED EC NO: S2012-0444 DRWN: CWANG25 CHKD: KJKOH APPR: NAGESHKN	2011/10/24 2011/12/02 2011/12/02	DESCRIPTION REV	QUALITY SYMBOLS	GENERAL TOLERANCES (UNLESS SPECIFIED)	DIMENSION STYLE	SCALE	DESIGN UNITS	THIRD ANGLE PROJECTION	
			$\nabla = 0$ $\square = 0$	mm INCH 4 PLACES ± --- ± --- 3 PLACES ± --- ± --- 2 PLACES ± 0.1 ± --- 1 PLACE ± --- ± --- ANGULAR ± 2 °	MM ONLY	NTS	METRIC		
				DRAFT WHERE APPLICABLE MUST REMAIN WITHIN DIMENSIONS	DRAWN BY: MKAMARAU CHECKED BY: MKAMARAU APPROVED BY: NAGESHKN MATERIAL NO.	DATE: 2008/10/14 DATE: 2008/10/14 DATE: 2010/11/19	TITLE: MICRO HDMI, TYPE-D 0.4MM PITCH, 19CKT RECEPTACLE CONNECTOR MOLEX INCORPORATED		
					SEE TABLE	DOCUMENT NO. SD-46765-001	SHEET NO. 5 OF 5		

Компания «Life Electronics» занимается поставками электронных компонентов импортного и отечественного производства от производителей и со складов крупных дистрибьюторов Европы, Америки и Азии.

С конца 2013 года компания активно расширяет линейку поставок компонентов по направлению коаксиальный кабель, кварцевые генераторы и конденсаторы (керамические, пленочные, электролитические), за счёт заключения дистрибьюторских договоров

Мы предлагаем:

- Конкуренеспособные цены и скидки постоянным клиентам.
- Специальные условия для постоянных клиентов.
- Подбор аналогов.
- Поставку компонентов в любых объемах, удовлетворяющих вашим потребностям.
- Приемлемые сроки поставки, возможна ускоренная поставка.
- Доставку товара в любую точку России и стран СНГ.
- Комплексную поставку.
- Работу по проектам и поставку образцов.
- Формирование склада под заказчика.
- Сертификаты соответствия на поставляемую продукцию (по желанию клиента).
- Тестирование поставляемой продукции.
- Поставку компонентов, требующих военную и космическую приемку.
- Входной контроль качества.
- Наличие сертификата ISO.

В составе нашей компании организован Конструкторский отдел, призванный помогать разработчикам, и инженерам.

Конструкторский отдел помогает осуществить:

- Регистрацию проекта у производителя компонентов.
- Техническую поддержку проекта.
- Защиту от снятия компонента с производства.
- Оценку стоимости проекта по компонентам.
- Изготовление тестовой платы монтаж и пусконаладочные работы.



Тел: +7 (812) 336 43 04 (многоканальный)

Email: org@lifeelectronics.ru