

AMIS-30512

Micro-Stepping Motor Driver

Introduction

The AMIS-30512 is a micro-stepping stepper motor driver for bipolar stepper motors. The chip is connected through I/O pins and a SPI interface with an external microcontroller. It has an on-chip voltage regulator, reset-output and watchdog reset, able to supply peripheral devices. The AMIS-30512 contains a current-translation table and takes the next micro-step depending on the clock signal on the "NXT" input pin and the status of the "DIR" (=direction) register or input pin. The chip provides a so-called "speed and load angle" output. This allows the creation of stall detection algorithms and control loops based on load-angle to adjust torque and speed. It is using a proprietary PWM algorithm for reliable current control.

The AMIS-30512 is implemented in I2T100 technology, enabling both high-voltage analog circuitry and digital functionality on the same chip. The chip is fully compatible with the automotive voltage requirements.

The AMIS-30512 is ideally suited for general-purpose stepper motor applications in the automotive, industrial, medical, and marine environment.

Key Features

- Dual H-Bridge for 2-phase Stepper Motors
- Programmable Peak-current up to 800 mA Using a 5-bit Current DAC
- On-chip Current Translator
- SPI Interface
- Speed and Load Angle Output
- Seven Step Modes from Full-step up to 32 Micro-steps
- Fully Integrated Current-sense
- PWM Current Control with Automatic Selection of Fast and Slow Decay
- Low EMC PWM with Selectable Voltage Slopes
- Active Fly-back Diodes
- Full Output Protection and Diagnosis
- Thermal Warning and Shutdown
- Compatible with 3.3 V Microcontrollers, 5 V Tolerant Inputs
- Integrated 5 V Regulator to Supply External Microcontroller
- Integrated Reset Function to Reset External Microcontroller
- Integrated Watchdog Function



ON Semiconductor®

<http://onsemi.com>

PIN ASSIGNMENT

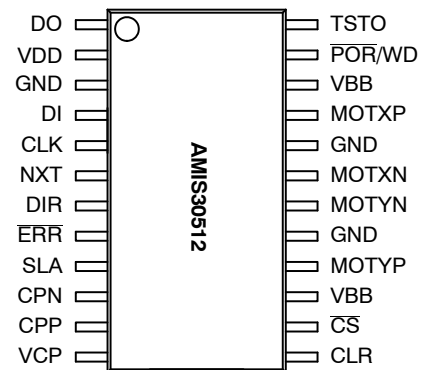

(Top View)

ORDERING INFORMATION

Device	Package	Shipping
AMIS30512	SOIC 24	Tape & Reel

Table of Contents

	Page
Introduction	1
Key Features	1
Ordering Information	1
Block Diagram	2
Pin List and Descriptions	3
Electrical Specifications	3
Typical Application Schematic	9
Functional Description	10
SPI Interface	21
Soldering Information	29
Package Outline	30

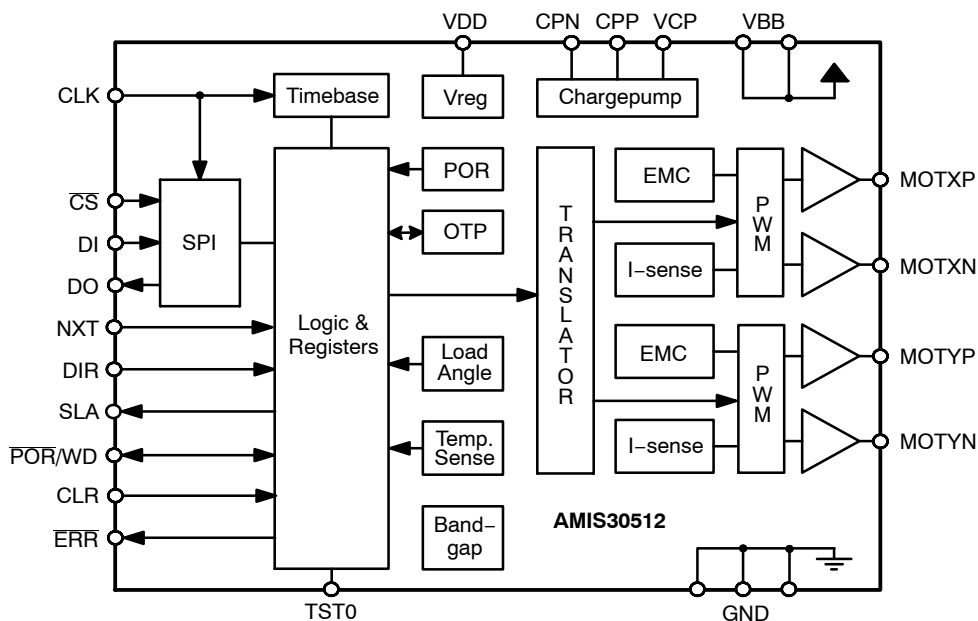

Figure 1. Block Diagram

Table 1. Pin List and Descriptions

Name	Pin	Description
DO	1	SPI data output (open drain)
VDD	2	Logic Supply Input (needs external decoupling capacitor)
GND	3	Ground
DI	4	SPI data in
CLK	5	SPI clock input
NXT	6	Next micro-step input
DIR	7	Direction input
ERR	8	Error Output (open drain)
SLA	9	Speed Load Angle Output
CPN	10	Negative connection of charge pump capacitor
CPP	11	Positive connection of charge pump capacitor
VCP	12	Charge-pump filter-capacitor
CLR	13	"Clear" = Chip Reset input
CS	14	SPI chip select input
VBB	15	High Voltage Supply Input
MOTYP	16	Negative end of phase Y coil output
GND	17	Ground
MOTYN	18	Positive end of phase Y coil output
MOTXN	19	Positive end of phase X coil output
GND	20	Ground
MOTXP	21	Negative end of phase X coil output
VBB	22	High Voltage Supply Input
POR/WD	23	Power-on-reset (POR) and watchdog reset output (open drain)
TST0	24	Test pin input (to be tied to ground in normal operation)

Table 2. Absolute Maximum Ratings

Symbol	Parameter	Min.	Max.	Units
V _{BB}	Analog DC supply voltage (Note 1)	-0.3	+40	V
T _{strg}	Storage temperature	-55	+160	°C
T _{amb}	Ambient temperature under bias	-50	+150	°C
V _{ESD}	Electrostatic discharges on component level (Note 2)	-2	+2	kV

Stresses exceeding Maximum Ratings may damage the device. Maximum Ratings are stress ratings only. Functional operation above the Recommended Operating Conditions is not implied. Extended exposure to stresses above the Recommended Operating Conditions may affect device reliability.

1. For limited time < 0.5 s.
2. Human body model (100 pF via 1.5 kΩ, according to JEDEC EIA-JESD22-A114-B).

Table 3. Recommended Operating Conditions

Symbol	Parameter	Min.	Max.	Units
V _{BB}	Analog DC supply	+6	+30	V
T _a	Ambient temperature V _{BB} ≤ +18	-40	+125	°C
T _a	Ambient temperature V _{BB} ≤ +30	-40	+85	°C
T _j	Junction temperature		+160	°C

NOTE: Operating ranges define the limits for functional operation and parametric characteristics of the device. Note that the functionality of the chip outside these operating ranges is not guaranteed. Operating outside the recommended operating ranges for extended periods of time may affect device reliability.

AMIS-30512

Table 4. DC Parameters (The DC parameters are given for V_{BB} and temperature in their operating ranges unless otherwise specified. Convention: currents flowing in the circuit are defined as positive.)

Symbol	Pin(s)	Parameter	Remark/Test Conditions	Min.	Typ.	Max.	Unit
--------	--------	-----------	------------------------	------	------	------	------

SUPPLY INPUTS

V_{BB}	VBB	Nominal operating supply range		6		30	V
I_{BB}		Total current consumption	Unloaded outputs			8	mA
V_{DD}	VDD	Regulated output voltage		4.75	5	5.25	V
I_{LOAD}		Max. output current	$6\text{ V} < V_{BB} < 8\text{ V}$	20			mA
			$8\text{ V} < V_{BB} < 30\text{ V}$	50			mA
I_{DDLIM}		Current limitation	VDD shorted to ground			200	mA
I_{LOAD_PD}		Output current in power down		1			mA

POWER-ON-RESET (POR)

V_{DDH}	VDD	Internal POR comparator threshold	VDD rising	4.0	4.25	4.4	V
V_{DDL}		Internal POR comparator threshold	VDD falling		3.68		V

MOTORDRIVER

$I_{MDmax,Peak}$	MOTXP MOTXN MOTYP MOTYN	Max current through motor coil in normal operation	$T_j < T_{std}$		800		mA
I_{MDabs}		Absolute error on coil current		-10		10	%
I_{MDrel}		Error on current ratio I_{coilx} / I_{coily}		-7		7	%
I_{SET_TC}		Temperature coefficient of coil current set-level, CUR[4:0] = 0..31	$-40^{\circ}\text{C} \leq T_j \leq 160^{\circ}\text{C}$		-240		ppm/ $^{\circ}\text{C}$
R_{HS}		On-resistance high-side driver, CUR[4:0] = 0...31; Range 0...3	$V_{bb} = 12\text{ V}, T_j = 27^{\circ}\text{C}$		0.45	0.56	Ω
			$V_{bb} = 12\text{ V}, T_j = 160^{\circ}\text{C}$		0.94	1.25	Ω
R_{LS3}		On-resistance low-side driver, CUR[4:0] = 23...31; Range 3	$V_{bb} = 12\text{ V}, T_j = 27^{\circ}\text{C}$		0.45	0.56	Ω
			$V_{bb} = 12\text{ V}, T_j = 160^{\circ}\text{C}$		0.94	1.25	Ω
R_{LS2}		On-resistance low-side driver, CUR[4:0] = 16...22; Range 2	$V_{bb} = 12\text{ V}, T_j = 27^{\circ}\text{C}$		0.90	1.2	Ω
			$V_{bb} = 12\text{ V}, T_j = 160^{\circ}\text{C}$		1.9	2.5	Ω
R_{LS1}		On-resistance low-side driver, CUR[4:0] = 9...15; Range 1	$V_{bb} = 12\text{ V}, T_j = 27^{\circ}\text{C}$		1.8	2.3	Ω
			$V_{bb} = 12\text{ V}, T_j = 160^{\circ}\text{C}$		3.8	5.0	Ω
R_{LS0}		On-resistance low-side driver, CUR[4:0] = 0...8; Range 0	$V_{bb} = 12\text{ V}, T_j = 27^{\circ}\text{C}$		3.6	4.5	Ω
			$V_{bb} = 12\text{ V}, T_j = 160^{\circ}\text{C}$		7.5	10	Ω
I_{Mpd}		Pull-down current	HiZ mode		0.5		mA

LOGIC INPUTS

I_{leak}	DI, CLK	Input leakage (Note 3)	$T_j = 160^{\circ}\text{C}$			1	μA
V_{IL}	NXT, DIR	Logic low threshold		0		0.65	V
V_{IH}	CLR, CSB	Logic high threshold		2.20		V_{DD}	V
R_{pd_CLR}	CLR	Internal pull-down resistor		120		300	$\text{k}\Omega$
R_{pd_TST}	TST0	Internal pull-down resistor		3		9	$\text{k}\Omega$

3. Not valid for pins with internal pull-down resistor
4. No more than 100 cumulated hours in life time above T_{tw}
5. Thermal shutdown and low temperature warning are derived from thermal warning.

AMIS-30512

Table 4. DC Parameters (The DC parameters are given for V_{BB} and temperature in their operating ranges unless otherwise specified. Convention: currents flowing in the circuit are defined as positive.)

Symbol	Pin(s)	Parameter	Remark/Test Conditions	Min.	Typ.	Max.	Unit
--------	--------	-----------	------------------------	------	------	------	------

LOGICAL OUTPUTS

V_{OL}	DO, ERRB, POR/WD	Logic Low level open drain	$I_{OL} = 5 \text{ mA}$			0.5	V
----------	------------------	----------------------------	-------------------------	--	--	-----	---

THERMAL WARNING AND SHUTDOWN

T_{tw}		Thermal warning		138	145	152	$^{\circ}\text{C}$
T_{tsd} (Notes 4,5)		Thermal shutdown			$T_{tw} + 20$		$^{\circ}\text{C}$

CHARGE PUMP

V_{cp}	VCP	Output voltage	$6 \text{ V} < V_{BB} < 15 \text{ V}$		$2 * V_{BB} - 2.5$		V
			$15 \text{ V} < V_{BB} < 30 \text{ V}$	$V_{BB} + 11$	$V_{BB} + 12.8$	$V_{BB} + 15$	V
C_{buffer}		External buffer capacitor		180	220	470	nF
C_{pump}	CPP CPN	External pump capacitor		180	220	470	nF

SPEED AND LOAD ANGLE OUTPUT

V_{out}	SLA	Output voltage range		0.5		4.5	V
V_{off}		Output offset the SLA pin	$0.2 \text{ V} < V_{sla} < V_{dd} - 0.2 \text{ V}$	-25		25	mV
R_{out}		Output resistance SLA pin				1	$k\Omega$
C_{load}		Load capacitance SLA pin				50	pF
G_{sla}		Gain of SLA pin = V_{BEMF} / V_{COIL}	SLAG=0 SLAG=1			0,5 0,25	

3. Not valid for pins with internal pull-down resistor
4. No more than 100 cumulated hours in life time above T_{tw}
5. Thermal shutdown and low temperature warning are derived from thermal warning.

Table 5. AC Parameters (The AC parameters are given for V_{BB} and temperature in their operating ranges.)

Symbol	Pin(s)	Parameter	Remark/Test Conditions	Min.	Typ.	Max.	Unit
--------	--------	-----------	------------------------	------	------	------	------

INTERNAL OSCILLATOR

f_{osc}		Frequency of internal oscillator		3.6	4	4.4	MHz
-----------	--	----------------------------------	--	-----	---	-----	-----

MOTORDRIVER

f_{PWM}	MOTXP MOTXN MOTYP MOTYN	PWM frequency	$\langle PWMF \rangle = 0$	20.8	22.8	24.8	kHz
		Double PWM frequency	$\langle PWMF \rangle = 1$	41.6	45.6	49.6	kHz
f_{JF}		PWM Jitter frequency	Not measured in production		50		Hz
		PWM Jitter depth			7		% f_{PWM}
T_{S_RISE}		turn-on voltage slope, 10% to 90% $I_{MD} = 800 \text{ mA}$	EMC[1:0] = 00		150		$V/\mu\text{s}$
			EMC[1:0] = 01		100		$V/\mu\text{s}$
			EMC[1:0] = 10		50		$V/\mu\text{s}$
			EMC[1:0] = 11		25		$V/\mu\text{s}$
T_{S_FALL}		turn-off voltage slope, 90% to 10% $I_{MD} = 800 \text{ mA}$	EMC[1:0] = 00		150		$V/\mu\text{s}$
			EMC[1:0] = 01		100		$V/\mu\text{s}$
			EMC[1:0] = 10		50		$V/\mu\text{s}$
			EMC[1:0] = 11		25		$V/\mu\text{s}$
t_{OC}		Open coil detection time			200	ms	

AMIS-30512

Table 5. AC Parameters (The AC parameters are given for V_{BB} and temperature in their operating ranges.)

Symbol	Pin(s)	Parameter	Remark/Test Conditions	Min.	Typ.	Max.	Unit
DIGITAL OUTPUTS							
t_{H2L}	DO ERRB	Output fall-time from V_{inH} to V_{inL}	Capacitive load 50 pF			50	ns
CHARGE PUMP							
f_{CP}	CPN CPP	Charge pump frequency			250		kHz
t_{CPU}	MOTxx	Start-up time of charge pump	For typ. value C_{buffer} and C_{pump}			2	ms
CLR FUNCTION							
t_{CLR}	CLR	Hard reset duration time		20		90	μ s
NXT FUNCTION							
t_{NXT_HI}	NXT	NXT minimum, high pulse width	See Figure 2	2			μ s
t_{NXT_LO}		NXT minimum, low pulse width	See Figure 2	2			μ s
t_{DIR_SET}		NXT hold time, following change of DIR	See Figure 2	0.5			μ s
t_{DIR_HOLD}		NXT hold time, before change of DIR	See Figure 2	0.5			μ s
POWER-UP							
t_{PU}	POR/ WD	Power-up time	$V_{BB} = 12$ V, $I_{LOAD} = 50$ mA, $C_{LOAD} = 220$ nF. See Figure 3			110	μ s
t_{PD}		Power-down time	$V_{BB} = 12$ V, $I_{LOAD} = 50$ mA, $C_{LOAD} = 220$ nF. . See Figure 3			110	μ s
t_{POR}		Reset duration	See Figure 3		100		ms
t_{RF}		Reset filter time	See Figure 3		1		μ s
WATCHDOG							
t_{WDTO}	POR/ WD	Watchdog time out interval	See Figure 3	32		512	ms
t_{WDPR}		Prohibited watchdog acknowledge delay	See Figure 3		2		ms
t_{WDRD}		Watchdog reset delay			1		μ s

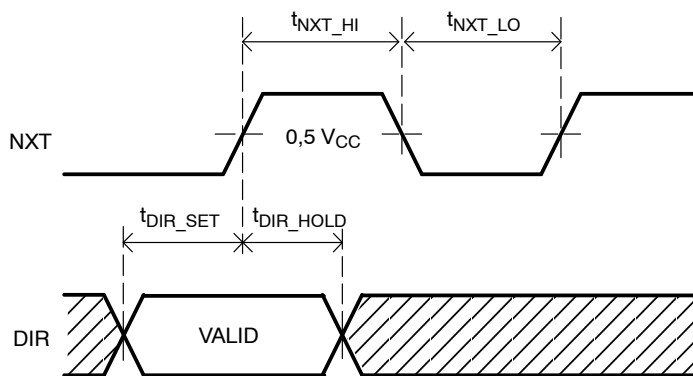

Figure 2. NXT-input Timing Diagram

AMIS-30512

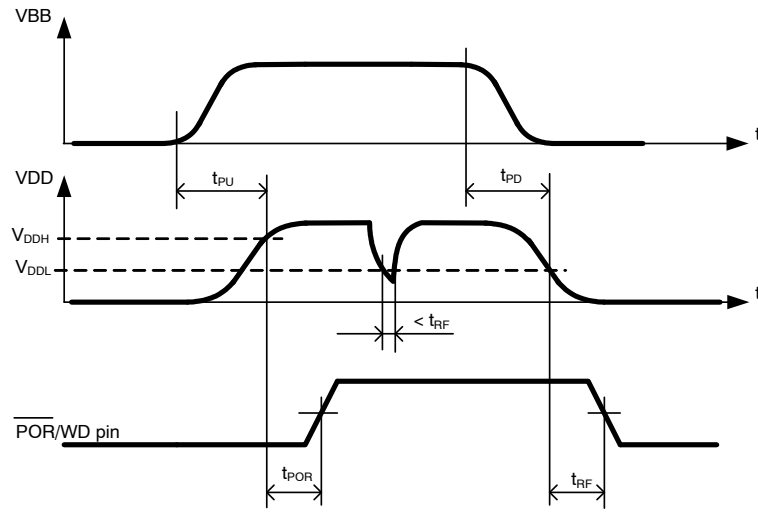

Figure 3. Power-on-Reset Timing Diagram

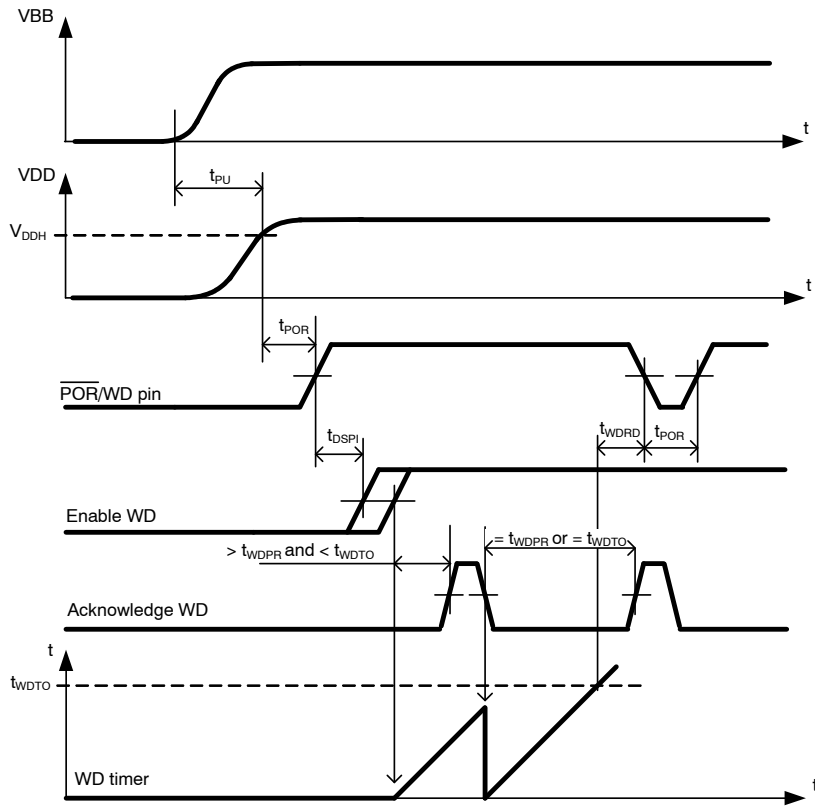

Figure 4. Watchdog Timing Diagram

Table 6. SPI Timing Parameters

Symbol	Parameter	Min.	Typ.	Max.	Unit
t_{CLK}	SPI clock period	1			μs
t_{CLK_HIGH}	SPI clock high time	100			ns
t_{CLK_LOW}	SPI clock low time	100			ns
t_{SET_DI}	DI set up time, valid data before rising edge of CLK	50			ns
t_{HOLD_DI}	DI hold time, hold data after rising edge of CLK	50			ns
t_{CSB_HIGH}	CSB high time	2.5			μs
t_{SET_CSB}	CSB set up time, CSB low before rising edge of CLK	100			ns
t_{SET_CLK}	CLK set up time, CLK low before rising edge of CSB	100			ns

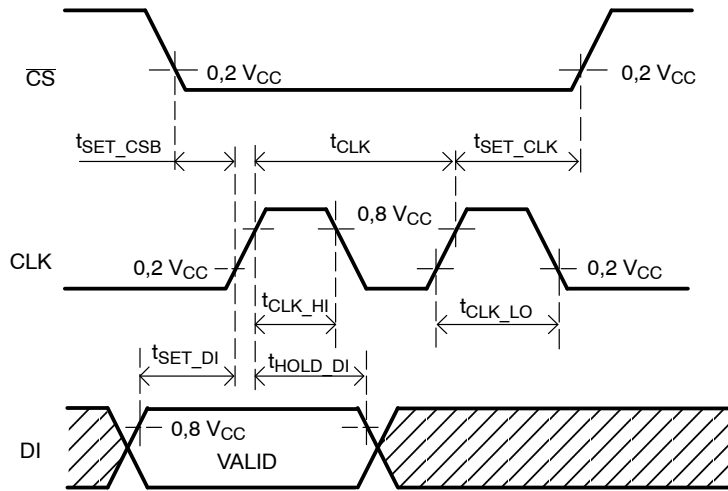

Figure 5. SPI Timing

AMIS-30512

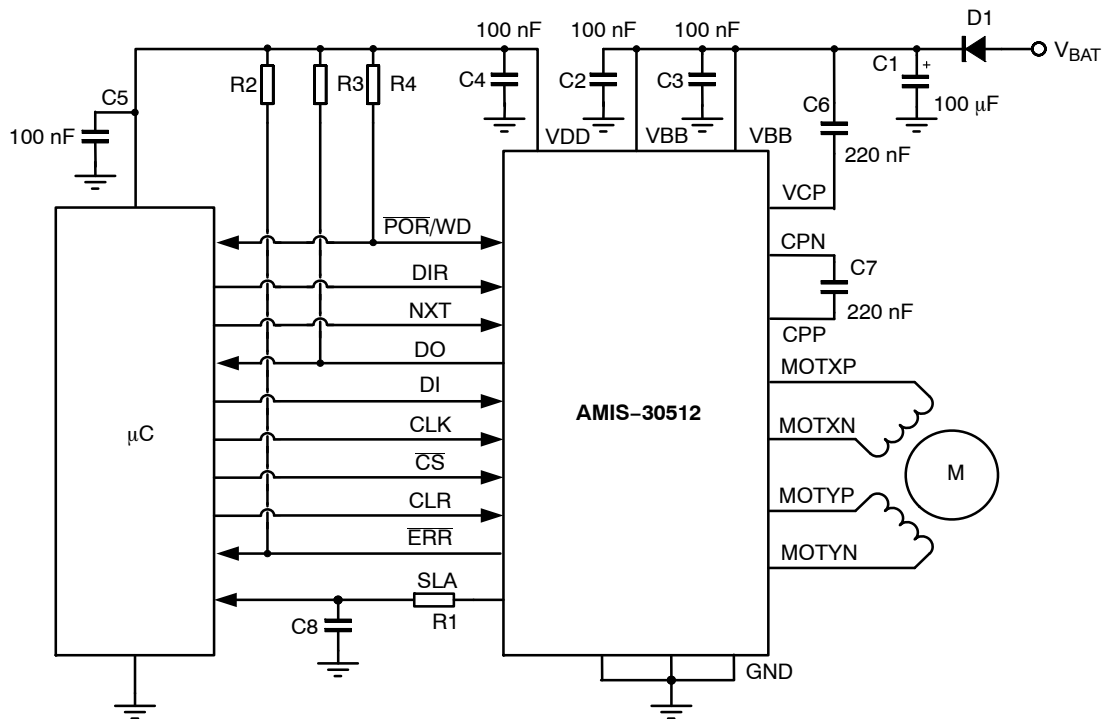

Figure 6. Typical Application Schematic

Table 7. External Components List and Description

Component	Function	Typ. Value	Tolerance	Unit
C ₁	V _{BB} buffer capacitor (Note 6)	100	-20 +80%	µF
C ₂ , C ₃	V _{BB} decoupling block capacitor	100	-20 +80%	nF
C ₄	V _{DD} buffer capacitor	220	±20%	nF
C ₅	V _{DD} buffer capacitor	100	±20%	nF
C ₆	Charge pump buffer capacitor	220	±20%	nF
C ₇	Charge pump pumping capacitor	220	±20%	nF
C ₈	Low pass filter SLA	1	±20%	nF
R ₁	Low pass filter SLA	5.6	±1%	kΩ
R ₂ , R ₃ , R ₄	Pull up resistor	4.7	±1%	kΩ
D ₁	Optional reverse protection diode	e.g. 1N4003		

6. Low ESR < 1 Ohm.

Functional Description

H-Bridge Drivers

A full H-bridge is integrated for each of the two stator windings. Each H-bridge consists of two low-side and two high-side N-type MOSFET switches. Writing logic '0' in bit <MOTEN> disables all drivers (high-impedance). Writing logic '1' in this bit enables both bridges and current can flow in the motor stator windings.

In order to avoid large currents through the H-bridge switches, it is guaranteed that the top- and bottom-switches of the same half-bridge are never conductive simultaneously (interlock delay).

A two-stage protection against shorts on motor lines is implemented. In a first stage, the current in the driver is limited. Secondly, when excessive voltage is sensed across the transistor, the transistor is switched-off.

In order to reduce the radiated/conducted emission, voltage slope control is implemented in the output switches. The output slope is defined by the gate-drain capacitance of output transistor and the (limited) current that drives the gate. There are two trimming bits for slope control (Table 25: SPI Control Parameter Overview EMC[1:0]).

The power transistors are equipped with so-called "active diodes": when a current is forced through the transistor switch in the reverse direction, i.e. from source to drain, then the transistor is switched on. This ensures that most of the current flows through the channel of the transistor instead of through the inherent parasitic drain-bulk diode.

Depending on the desired current range and the micro-step position at hand, the R_{dson} of the low-side transistors will be adapted such that excellent current-sense accuracy is maintained. The R_{dson} of the high-side transistors remain unchanged, see Table 4: DC Parameters for more details.

PWM Current Control

A PWM comparator compares continuously the actual winding current with the requested current and feeds back the information to a digital regulation loop. This loop then generates a PWM signal, which turns on/off the H-bridge switches. The switching points of the PWM duty-cycle are synchronized to the on-chip PWM clock. The frequency of the PWM controller can be doubled and an artificial jitter can be added (Table 14: SPI Control Register 1). The PWM frequency will not vary with changes in the supply voltage. Also variations in motor-speed or load-conditions of the motor have no effect. There are no external components required to adjust the PWM frequency.

Automatic Forward and Slow-Fast Decay

The PWM generation is in steady-state using a combination of forward and slow-decay. The absence of fast-decay in this mode, guarantees the lowest possible current-ripple "by design". For transients to lower current levels, fast-decay is automatically activated to allow high-speed response. The selection of fast or slow decay is completely transparent for the user and no additional parameters are required for operation.

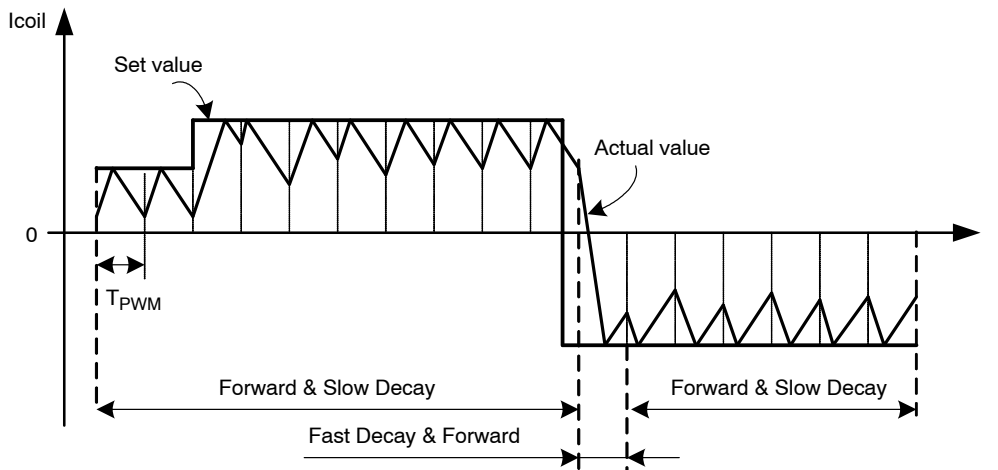

Figure 7. Forward and Slow/Fast Decay PWM

In case the supply voltage is lower than $2 \cdot B_{emf}$, then the duty cycle of the PWM is adapted automatically to $>50\%$ to maintain the requested average current in the coils. This process is completely automatic and requires no additional

parameters for operation. The over-all current-ripple is divided by two if PWM frequency is doubled (Table 14: SPI Control Register 1).

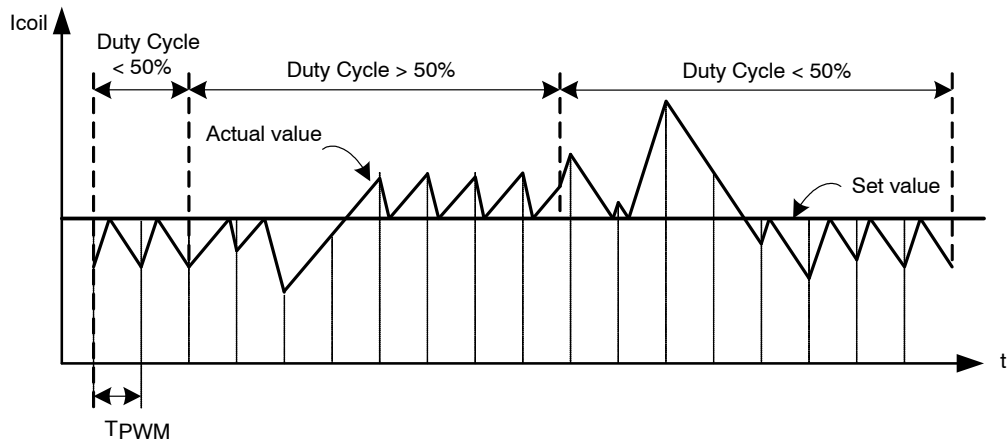

Figure 8. Automatic Duty Cycle Adaptation

Step Translator

Step Mode

The step translator provides the control of the motor by means of SPI register Stepmode: SM[2:0], SPI register DIRCNTRL, and input pins DIR and NXT. It is translating consecutive steps in corresponding currents in both motor coils for a given step mode.

One out of seven possible stepping modes can be selected through SPI-bits SM[2:0] (Table 26: SPI Control Parameter Overview SM[2:0]) After power-on or hard reset, the coil-current translator is set to the default 1/32 micro-stepping at position '0'. Upon changing the step

mode, the translator jumps to position 0* of the corresponding stepping mode. When remaining in the same step mode, subsequent translator positions are all in the same column and increased or decreased with 1. Table 9 lists the output current versus the translator position.

As shown in Figure 9 the output current-pairs can be projected approximately on a circle in the (Ix,Iy) plane. There is, however, one exception: uncompensated half step. In this step mode the currents are not regulated to a fraction of Imax but are in all intermediate steps regulated at 100 percent. In the (Ix,Iy) plane the current-pairs are projected on a square. Table 8 lists the output current versus the translator position for this case.

Table 8. Square Translator Table for Full Step and Uncompensated Half Step

MSP[6:0]	Stepmode (SM[2:0])		% of Imax	
	101	110	Coil x	Coil y
	Uncompensated Half-Step	Full Step		
000 0000	0*	-	0	100
001 0000	1	1	100	100
010 0000	2	-	100	0
011 0000	3	2	100	-100
100 0000	4	-	0	-100
101 0000	5	3	-100	-100
110 0000	6	-	-100	0
111 0000	7	0*	-100	100

AMIS-30512

Table 9. Circular Translator Table

MSP[6:0]	Stepmode (SM[2:0])					% of I _{max}	
	000	001	010	011	100	Coil x	Coil y
	1/32	1/16	1/8	1/4	1/2		
000 0000	'0'	0*	0*	0*	0*	0	100
000 0001	1	-	-	-	-	3.5	98.8
000 0010	2	1	-	-	-	8.1	97.7
000 0011	3	-	-	-	-	12.7	96.5
000 0100	4	2	1	-	-	17.4	95.3
000 0101	5	-	-	-	-	22.1	94.1
000 0110	6	3	-	-	-	26.7	93
000 0111	7	-	-	-	-	31.4	91.8
000 1000	8	4	2	1	-	34.9	89.5
000 1001	9	-	-	-	-	38.3	87.2
000 1010	10	5	-	-	-	43	84.9
000 1011	11	-	-	-	-	46.5	82.6
000 1100	12	6	3	-	-	50	79
000 1101	13	-	-	-	-	54.6	75.5
000 1110	14	7	-	-	-	58.1	72.1
000 1111	15	-	-	-	-	61.6	68.6
001 0000	16	8	4	2	1	65.1	65.1
001 0001	17	-	-	-	-	68.6	61.6
001 0010	18	9	-	-	-	72.1	58.1
001 0011	19	-	-	-	-	75.5	54.6
001 0100	20	10	5	-	-	79	50
001 0101	21	-	-	-	-	82.6	46.5
001 0110	22	11	-	-	-	84.9	43
001 0111	23	-	-	-	-	87.2	38.3
001 1000	24	12	6	3	-	89.5	34.9
001 1001	25	-	-	-	-	91.8	31.4
001 1010	26	13	-	-	-	93	26.7
001 1011	27	-	-	-	-	94.1	22.1
001 1100	28	14	7	-	-	95.3	17.4
001 1101	29	-	-	-	-	96.5	12.7
001 1110	30	15	-	-	-	97.7	8.1
001 1111	31	-	-	-	-	98.8	3.5
010 0000	32	16	8	4	2	100	0
010 0001	33	-	-	-	-	98.8	-3.5
010 0010	34	17	-	-	-	97.7	-8.1
010 0011	35	-	-	-	-	96.5	-12.7
010 0100	36	18	9	-	-	95.3	-17.4
010 0101	37	-	-	-	-	94.1	-22.1
010 0110	38	19	-	-	-	93	-26.7
010 0111	39	-	-	-	-	91.8	-31.4
010 1000	40	20	10	5	-	89.5	-34.9
010 1001	41	-	-	-	-	87.2	-38.3
010 1010	42	21	-	-	-	84.9	-43

AMIS-30512

Table 9. Circular Translator Table

MSP[6:0]	Stepmode (SM[2:0])					% of I _{max}	
	000	001	010	011	100	Coil x	Coil y
	1/32	1/16	1/8	1/4	1/2		
010 1011	43	-	-	-	-	82.6	-46.5
010 1100	44	22	11	-	-	79	-50
010 1101	45	-	-	-	-	75.5	-54.6
010 1110	46	23	-	-	-	72.1	-58.1
010 1111	47	-	-	-	-	68.6	-61.6
011 0000	48	24	12	6	3	65.1	-65.1
011 0001	49	-	-	-	-	61.6	-68.6
011 0010	50	25	-	-	-	58.1	-72.1
011 0011	51	-	-	-	-	54.6	-75.5
011 0100	52	26	13	-	-	50	-79
011 0101	53	-	-	-	-	46.5	-82.6
011 0110	54	27	-	-	-	43	-84.9
011 0111	55	-	-	-	-	38.3	-87.2
011 1000	56	28	14	7	-	34.9	-89.5
011 1001	57	-	-	-	-	31.4	-91.8
011 1010	58	29	-	-	-	26.7	-93
011 1011	59	-	-	-	-	22.1	-94.1
011 1100	60	30	15	-	-	17.4	-95.3
011 1101	61	-	-	-	-	12.7	-96.5
011 1110	62	31	-	-	-	8.1	-97.7
011 1111	63	-	-	-	-	3.5	-98.8
100 0000	64	32	16	8	4	0	-100
100 0001	65	-	-	-	-	-3.5	-98.8
100 0010	66	33	-	-	-	-8.1	-97.7
100 0011	67	-	-	-	-	-12.7	-96.5
100 0100	68	34	17	-	-	-17.4	-95.3
100 0101	69	-	-	-	-	-22.1	-94.1
100 0110	70	35	-	-	-	-26.7	-93
100 0111	71	-	-	-	-	-31.4	-91.8
100 1000	72	36	18	9	-	-34.9	-89.5
100 1001	73	-	-	-	-	-38.3	-87.2
100 1010	74	37	-	-	-	-43	-84.9
100 1011	75	-	-	-	-	-46.5	-82.6
100 1100	76	38	19	-	-	-50	-79
100 1101	77	-	-	-	-	-54.6	-75.5
100 1110	78	39	-	-	-	-58.1	-72.1
100 1111	79	-	-	-	-	-61.6	-68.6
101 0000	80	40	20	10	5	-65.1	-65.1
101 0001	81	-	-	-	-	-68.6	-61.6
101 0010	82	41	-	-	-	-72.1	-58.1
101 0011	83	-	-	-	-	-75.5	-54.6
101 0100	84	42	21	-	-	-79	-50
101 0101	85	-	-	-	-	-82.6	-46.5

AMIS-30512

Table 9. Circular Translator Table

MSP[6:0]	Stepmode (SM[2:0])					% of I _{max}	
	000	001	010	011	100	Coil x	Coil y
	1/32	1/16	1/8	1/4	1/2		
101 0110	86	43	-	-	-	-84.9	-43
101 0111	87	-	-	-	-	-87.2	-38.3
101 1000	88	44	22	11	-	-89.5	-34.9
101 1001	89	-	-	-	-	-91.8	-31.4
101 1010	90	45	-	-	-	-93	-26.7
101 1011	91	-	-	-	-	-94.1	-22.1
101 1100	92	46	23	-	-	-95.3	-17.4
101 1101	93	-	-	-	-	-96.5	-12.7
101 1110	94	47	-	-	-	-97.7	-8.1
101 1111	95	-	-	-	-	-98.8	-3.5
110 0000	96	48	24	12	6	-100	0
110 0001	97	-	-	-	-	-98.8	3.5
110 0010	98	49	-	-	-	-97.7	8.1
110 0011	99	-	-	-	-	-96.5	12.7
110 0100	100	50	25	-	-	-95.3	17.4
110 0101	101	-	-	-	-	-94.1	22.1
110 0110	102	51	-	-	-	-93	26.7
110 0111	103	-	-	-	-	-91.8	31.4
110 1000	104	52	26	13	-	-89.5	34.9
110 1001	105	-	-	-	-	-87.2	38.3
110 1010	106	53	-	-	-	-84.9	43
110 1011	107	-	-	-	-	-82.6	46.5
110 1100	108	54	27	-	-	-79	50
110 1101	109	-	-	-	-	-75.5	54.6
110 1110	110	55	-	-	-	-72.1	58.1
110 1111	111	-	-	-	-	-68.6	61.6
111 0000	112	56	28	14	7	-65.1	65.1
111 0001	113	-	-	-	-	-61.6	68.6
111 0010	114	57	-	-	-	-58.1	72.1
111 0011	115	-	-	-	-	-54.6	75.5
111 0100	116	58	29	-	-	-50	79
111 0101	117	-	-	-	-	-46.5	82.6
111 0110	118	59	-	-	-	-43	84.9
111 0111	119	-	-	-	-	-38.3	87.2
111 1000	120	60	30	15	-	-34.9	89.5
111 1001	121	-	-	-	-	-31.4	91.8
111 1010	122	61	-	-	-	-26.7	93
111 1011	123	-	-	-	-	-22.1	94.1
111 1100	124	62	31	-	-	-17.4	95.3
111 1101	125	-	-	-	-	-12.7	96.5
111 1110	126	63	-	-	-	-8.1	97.7
111 1111	127	-	-	-	-	-3.5	98.8

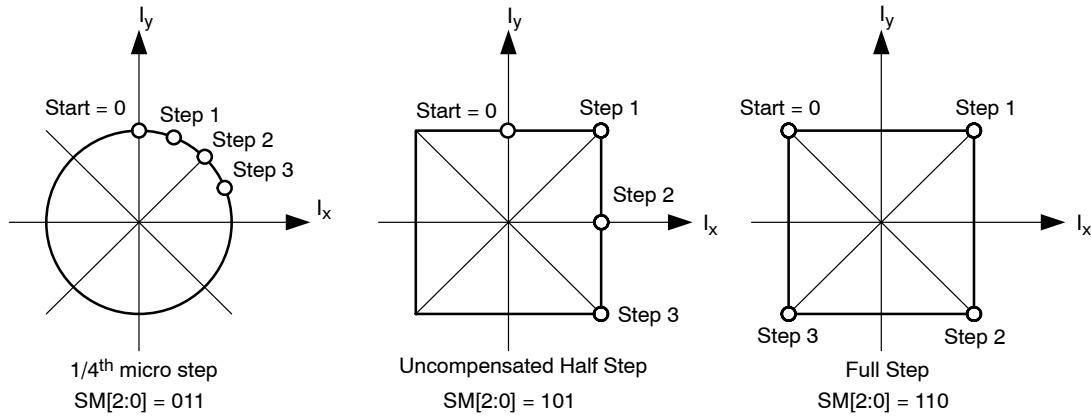

Figure 9. Translator Table: Circular and Square

Direction

The direction of rotation is selected by means of following combination of the DIR input pin and the SPI-controlled direction bit <DIRCTRL>. (Table 14: SPI Control Register 1)

NXT Input

Changes on the NXT input will move the motor current one step up/down in the translator table. Depending on the NXT-polarity bit <NXTP> (Table 14: SPI Control Register 1), the next step is initiated either on the rising edge or the falling edge of the NXT input.

Translator Position

The translator position can be read in Table 30: SPI Status Register 3. This is a 7-bit number equivalent to the 1/32th micro-step from Table 9: Circular Translator Table. The translator position is updated immediately following a NXT trigger.

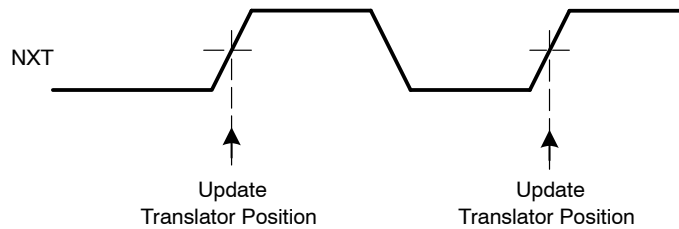

Figure 10. Translator Position Timing Diagram

Synchronization of Step Mode and NXT Input

When step mode is re-programmed to another resolution (Table 13: SPI Control Register 0), then this is put in effect immediately upon the first arriving “NXT” input. If the micro-stepping resolution is increased (see Figure 11 left hand side) then the coil currents will be regulated to the nearest micro-step, according to the fixed grid of the increased resolution. If however the micro-stepping resolution is decreased, then it is possible to introduce an offset (or phase shift) in the micro-step translator table.

If the step resolution is decreased at a translator table position that is shared both by the old and new resolution

setting, then the offset is zero and micro-stepping proceeds according to the translator table.

If the step resolution is decreased at a translator table position that is shared both by the old and new resolution setting, then the offset is zero and micro-stepping is proceeds according to the translator table.

If the translator position is **not** shared both by the old and new resolution setting, then the micro-stepping proceeds with an offset relative to the translator table (See Figure 11 right hand side).

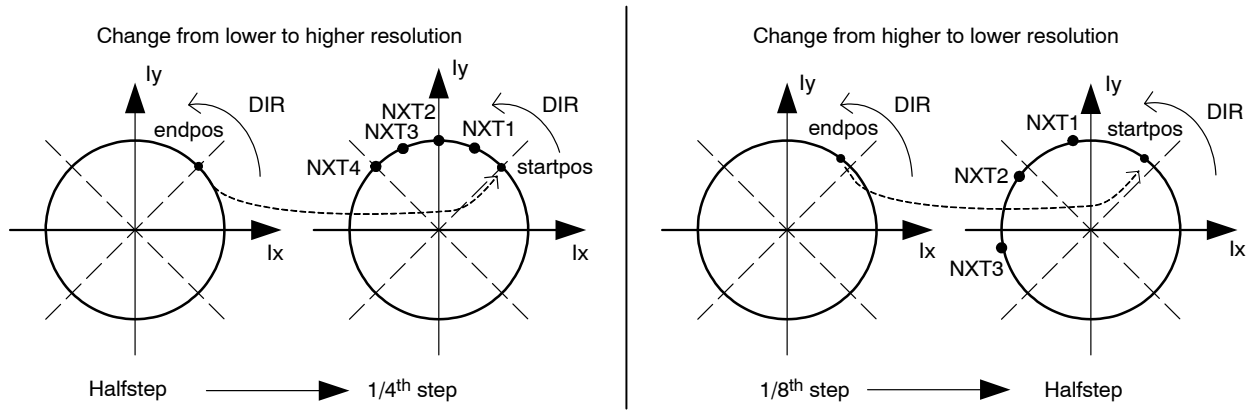

Left: Change from lower to higher resolution. The left-hand side depicts the ending half-step position during which a new step mode resolution was programmed. The right-hand side diagram shows the effect of subsequent NXT commands on the micro-step position.

Right: Change from higher to lower resolution. The left-hand side depicts the ending micro-step position during which a new step mode resolution was programmed. The right-hand side diagram shows the effect of subsequent NXT commands on the half-step position.

Figure 11. NXT-Step Mode Synchronization

NOTE: It is advised to reduce the micro-stepping resolution only at micro-step positions that overlap with desired micro-step positions of the new resolution.

Programmable Peak-Current

The amplitude of the current waveform in the motor coils (coil peak current = I_{max}) is adjusted by means of an SPI parameter “CUR[4:0]” (Table 13: SPI Control Register 0). Whenever this parameter is changed, the coil-currents will

be updated immediately at the next PWM period. The impedance of the bottom drivers is adapted with the current range: See Table 4: DC Parameters.

Table 10. Programmable Peak Current CUR[4:0]

Current Range	CUR[4:0] Index	Current (mA)	Current Range	CUR[4:0] Index	Current (mA)
0	0	15	2	16	181
	1	30		17	200
	2	45		18	221
	3	50		19	244
	4	55		20	269
	5	61		21	297
	6	67		22	328
	7	74		3	23
8	82	24	400		
1	9	91	25		441
	10	100	26		487
	11	110	27		538
	12	122	28		594
	13	135	29		656
	14	149	30		724
	15	164	31	800	

NOTE: Changing the current over different current ranges might lead to false over current triggering.

Speed and Load Angle Output

The SLA-pin provides an output voltage that indicates the level of the Back-e.m.f. voltage of the motor. This Back-e.m.f. voltage is sampled during every so-called “coil

current zero crossings”. Per coil, two zero-current positions exist per electrical period, yielding in total four zero-current observation points per electrical period.

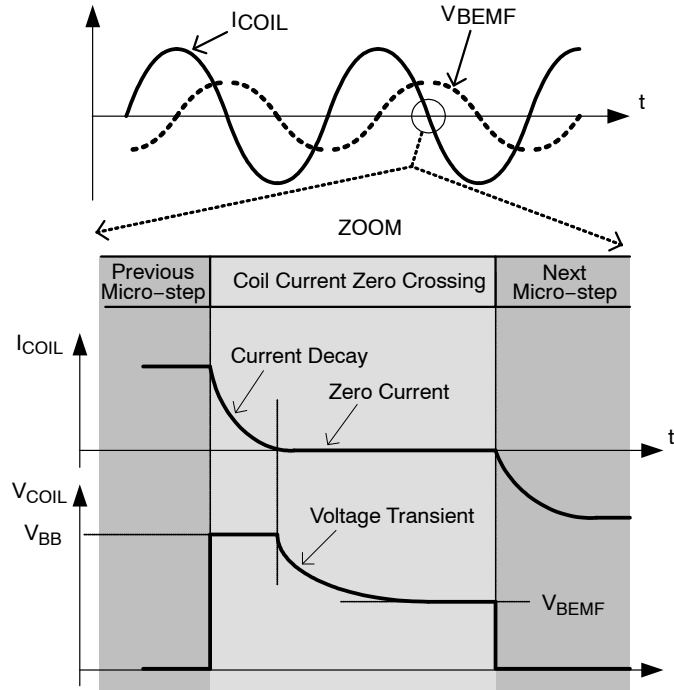

Figure 12. Principle of BEMF Measurement

Because of the relatively high recirculation currents in the coil during current decay, the coil voltage V_{COIL} shows a transient behavior. As this transient is not always desired in application software, two operating modes can be selected by means of the bit <SLAT> (see “SLA-transparency” in Table 15: SPI Control Register 2). The SLA pin shows in “transparent mode” full visibility of the voltage transient behavior. This allows a sanity-check of the speed-setting versus motor operation and characteristics and supply voltage levels. If the bit “SLAT” is cleared, then only the voltage samples at the end of each coil current zero crossing are visible on the SLA-pin. Because the transient behavior

of the coil voltage is not visible any more, this mode generates smoother Back e.m.f. input for post-processing, e.g. by software.

In order to bring the sampled Back e.m.f. to a descent output level (0 to 5 V), the sampled coil voltage V_{COIL} is divided by 2 or by 4. This divider is set through an SPI bit <SLAG>. (Table 15: SPI Control Register 2)

The following drawing illustrates the operation of the SLA-pin and the transparency-bit. “PWMsh” and “Icoil=0” are internal signals that define together with SLAT the sampling and hold moments of the coil voltage.

AMIS-30512

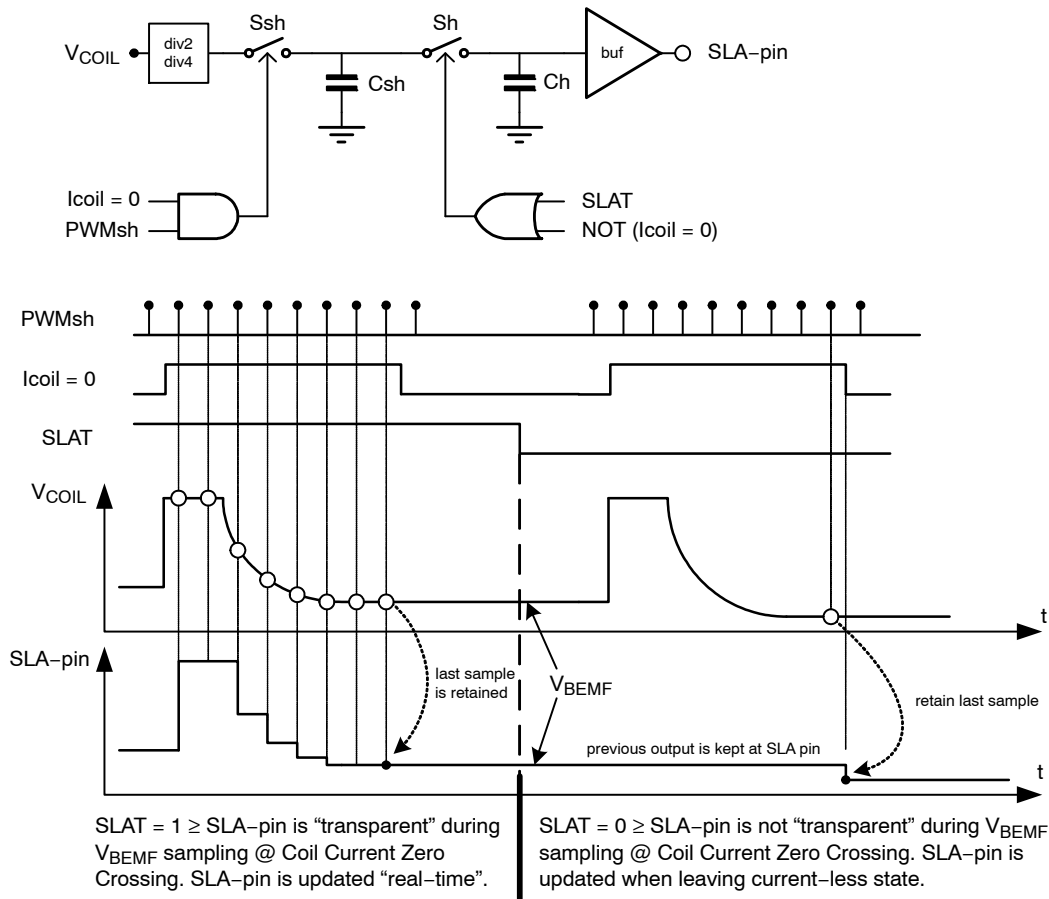

Figure 13. Timing Diagram of SLA-pin

Warning, Error Detection and Diagnostics Feedback

Thermal Warning and Shutdown

When junction temperature rises above T_{TW} , the thermal warning bit <TW> is set (Table 27: SPI Status Register 0). If junction temperature increases above thermal shutdown level, then the circuit goes in "thermal shutdown" mode, <TSD> bit is set and all driver transistors are disabled (high impedance) (Table 29: SPI Status Register 2). The conditions to reset flag <TSD> is to be at a temperature lower than T_{TW} and to clear the <TSD> flag by reading it using any SPI read command.

Over-Current Detection

The over-current detection circuit monitors the load current in each activated output stage. If the load current exceeds the over-current detection threshold, then the over-current flag is set and the drivers are switched off to reduce the power dissipation and to protect the integrated circuit. Each driver transistor has an individual detection bit in the Table 28: SPI Status Register 1 and Table 29: SPI Status Register 2 (<OVCXij> and <OVCIYij>). Error

condition is latched and the microcontroller needs to clean the status bits to reactivate the drivers.

NOTE: Successive reading the SPI Status Registers 1 and 2 in case of a short circuit condition, may lead to damage to the drivers.

Changing the current over different current ranges might lead to false over current triggering.

Open Coil Detection

Open coil detection is based on the observation of 100 percent duty cycle of the PWM regulator. If in a coil 100 percent duty cycle is detected for longer than $t_{OC} = 200$ ms then the related driver transistors are disabled (high-impedance) and an appropriate bit in the SPI status register is set (<OPENX> or <OPENY>). (Table 27: SPI Status Register 0).

Charge Pump Failure

The charge pump is an important circuit that guarantees low R_{dson} for all drivers, especially for low supply voltages. If the supply voltage is too low or external components are

not properly connected to guarantee sufficient low $R_{ds(on)}$ of the drivers, then the bit <CPFAIL> is set in Table 27: SPI Status Register 0. Also after power-on-reset the charge pump voltage will need the time t_{CPU} to exceed the required threshold. During that time <CPFAIL> will be set to “1”.

Error Output

This is a digital output to flag a problem to the external microcontroller. The signal on this output is active low and the logic combination of:

$$\text{NOT}(\text{ERRB}) = \text{<TW>} \text{ OR } \text{<TSD>} \text{ OR } \text{<OVCXij>} \text{ OR } \text{<OVCYij>} \text{ OR } \text{<OPENi>} \text{ OR } \text{<CPFAIL>}$$

Logic Supply Regulator

AMIS-30512 has an on-chip 5 V low-drop regulator with external decoupling capacitor to supply the digital part of the

chip, some low-voltage analog blocks and external circuitry. The voltage is derived from an internal bandgap reference. To calculate the available drive-current for external circuitry, the specified I_{load} should be reduced with the consumption of internal circuitry (unloaded outputs) and the loads connected to logic outputs. See DC parameters.

Power-On Reset (POR) Function

The open drain output pin $\overline{\text{POR}}/\text{WD}$ provides an “active low” reset for external purposes. At power-up of AMIS-30512, this pin will be kept low for some time to reset for example an external microcontroller. A small analog filter avoids resetting due to spikes or noise on the VDD supply.

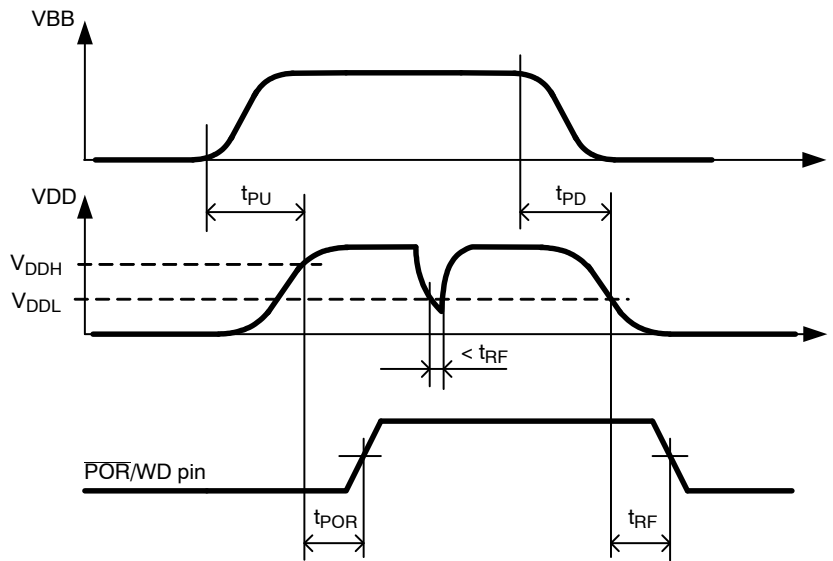

Figure 14. Power-on-Reset Timing Diagram

Watchdog Function

The watchdog function is enabled/disabled through <WDEN> bit (Table 12: SPI Control Register WR). Once this bit has been set to “1” (watchdog enable), the microcontroller needs to re-write this bit to clear an internal timer before the watchdog timeout interval expires. In case the timer is activated and WDEN is acknowledged too early (before t_{WDPR}) or not within the interval (after t_{WDTO}), then

a reset of the microcontroller will occur through $\overline{\text{POR}}/\text{WD}$ pin. In addition, a warm/cold boot bit <WD> is available in SPI Status Register 0 for further processing when the external microcontroller is alive again. The watchdog reset delay t_{WDRD} is determined by an internal delay of 0,5 μs added to an external delay formed by the pull up resistance and the capacitive load on the $\overline{\text{POR}}/\text{WD}$ pin.

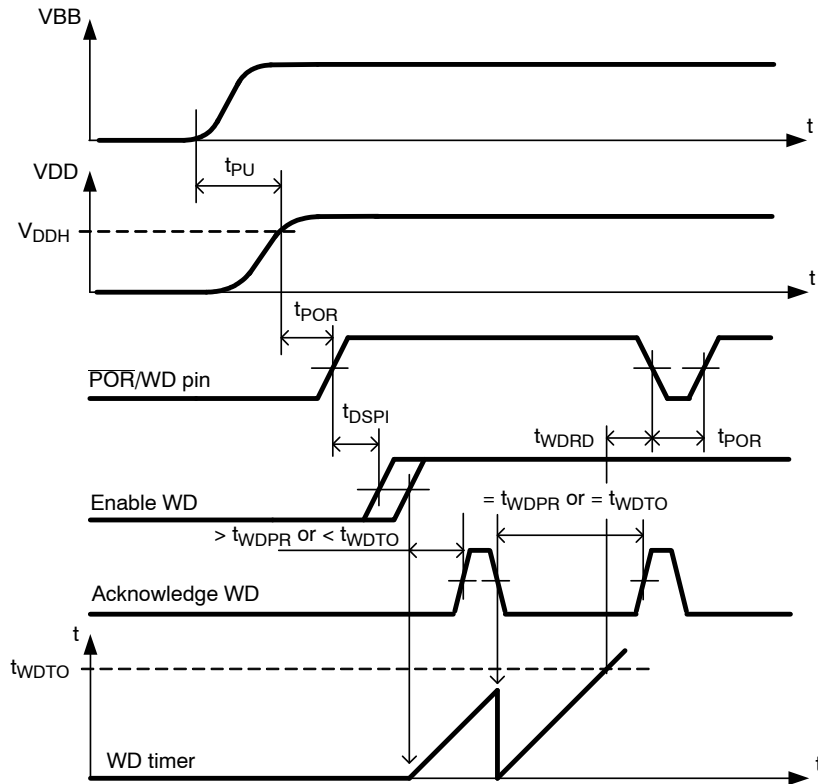

Figure 15. Watchdog Timing Diagram

NOTE: t_{DSPI} is the time needed by the external microcontroller to shift-in the <WDEN> bit after a power-up.

The duration of the watchdog timeout interval is programmable through the WDT [3:0] bits (Table 12: SPI Control Register WR). The timing is given in Table 11.

Table 11. Watchdog Timeout Interval as Function of WDT[3:0]

Index	WDT[3:0]				t_{WDTO} (ms)
0	0	0	0	0	32
1	0	0	0	1	64
2	0	0	1	0	96
3	0	0	1	1	128
4	0	1	0	0	160
5	0	1	0	1	192
6	0	1	1	0	224
7	0	1	1	1	256
8	1	0	0	0	288
9	1	0	0	1	320
A	1	0	1	0	352
B	1	0	1	1	384
C	1	1	0	0	416
D	1	1	0	1	448
E	1	1	1	0	480
F	1	1	1	1	512

CLR pin (=Hard Reset)

Logic 0 on CLR pin allows normal operation of the chip. To reset the complete digital inside AMIS-30512, the input CLR needs to be pulled to logic 1 during minimum time given by T_{CLR} . (Table 5: AC Parameters) This reset function clears all internal registers without the need of a power-cycle. The operation of all analog circuits is depending on the reset state of the digital, charge pump remains active. Logic 0 on CLR pin resumes normal operation again.

Sleep Mode

The bit <SLP> in Table 15: SPI Control Register 2 is provided to enter a so-called “sleep mode”. This mode allows reduction of current-consumption when the motor is not in operation. The effect of sleep mode is as follows:

- The drivers are put in HiZ
- All analog circuits are disabled and in low-power mode
- All internal registers are maintaining their logic content
- Pulses on NXT and DIR inputs are ignored
- SPI communication remains possible (slight current increase during SPI communication)
- Reset of chip is possible through CLR pin
- Oscillator and digital clocks are silent, except during SPI communication

Normal operation is resumed after writing logic ‘0’ to bit <SLP>. A start-up time t_{CPU} is needed for the charge pump to stabilize. After this time, NXT commands can be issued.

AMIS-30512

SPI Interface

The serial peripheral interface (SPI) allows an external microcontroller (Master) to communicate with AMIS-30512. The implemented SPI block is designed to interface directly with numerous micro-controllers from several manufacturers. AMIS-30512 acts always as a Slave and can't initiate any transmission. The operation of the device is configured and controlled by means of SPI registers which are observable for read and/or write from the Master.

SPI Transfer Format and Pin Signals

During a SPI transfer, data is simultaneously transmitted (shifted out serially) and received (shifted in serially). A serial clock line (CLK) synchronizes shifting and sampling of the information on the two serial data lines (DO and DI).

DO signal is the output from the Slave (AMIS-30512), and DI signal is the output from the Master. A chip select line (CSB) allows individual selection of a Slave SPI device in a multiple-slave system. The CSB line is active low. If AMIS-30512 is not selected, DO is pulled up with the external pull up resistor. Since AMIS-30512 operates as a Slave in MODE 0 (CPOL = 0; CPHA = 0) it always clocks data out on the falling edge and samples data in on rising edge of clock. The Master SPI port must be configured in MODE 0 too, to match this operation. The SPI clock idles low between the transferred bytes.

The diagram below is both a Master and a Slave timing diagram since CLK, DO and DI pins are directly connected between the Master and the Slave.

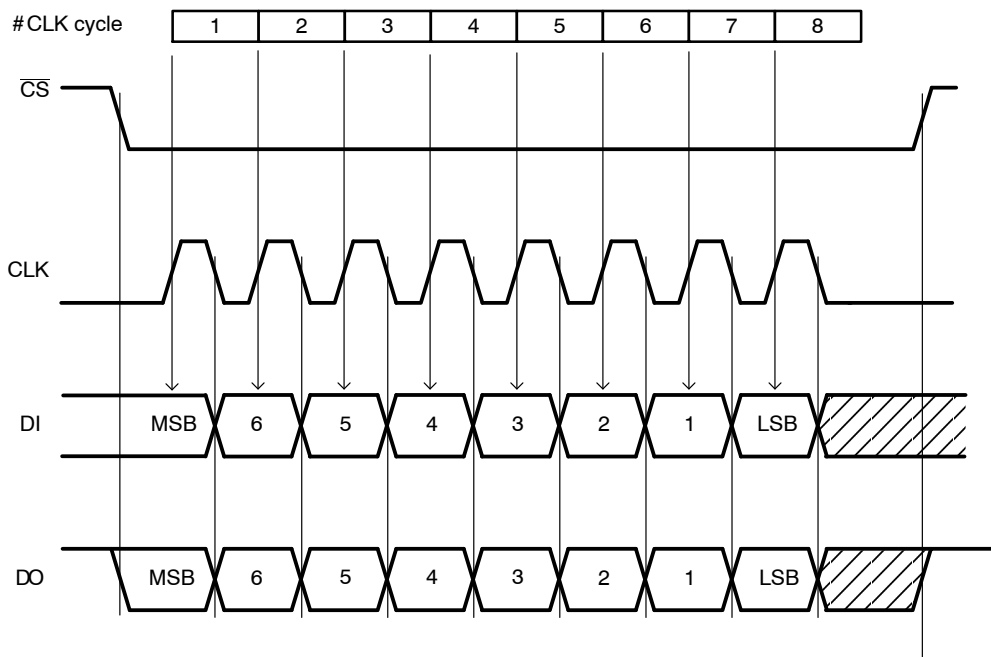

Figure 16. Timing Diagram of a SPI Transfer

NOTE: At the falling edge of the eight clock pulse the data-out shift register is updated with the content of the addressed internal SPI register. The internal SPI registers are updated at the first rising edge of the AMIS-30512 system clock when CSB = High

Transfer Packet:

Serial data transfer is assumed to follow MSB first rule. The transfer packet contains one or more bytes.

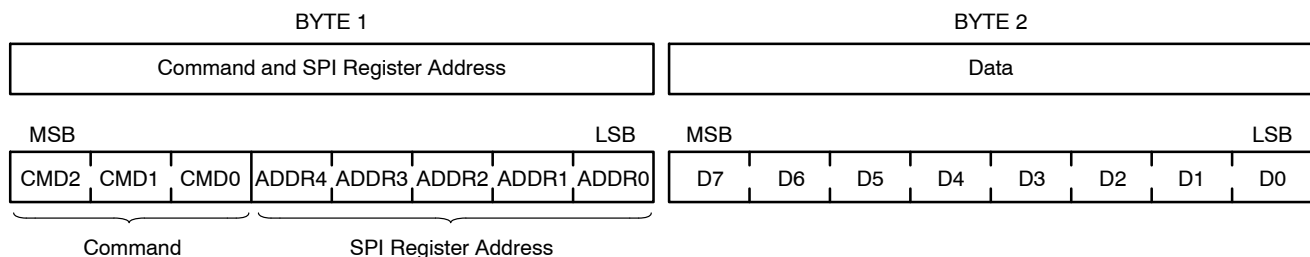

Figure 17. SPI Transfer Packet

Byte 1 contains the Command and the SPI Register Address and indicates to AMIS-30512 the chosen type of operation and addressed register. Byte 2 contains data, or sent from the Master in a WRITE operation, or received from AMIS-30512 in a READ operation.

2 command types can be distinguished in the communication between master and AMIS-30512:

- READ from SPI Register with address ADDR[4:0]:
CMD2 = “0”
- WRITE to SPI Register with address ADDR[4:0]:
CMD2 = “1”

READ Operation

If the Master wants to read data from Status or Control Registers, it initiates the communication by sending a READ command. This READ command contains the address of the SPI register to be read out. At the falling edge of the eight clock pulse the data-out shift register is updated with the content of the corresponding internal SPI register. In the next 8-bit clock pulse train this data is shifted out via DO pin. At the same time the data shifted in from DI (Master) should be interpreted as the following successive command or is dummy data.

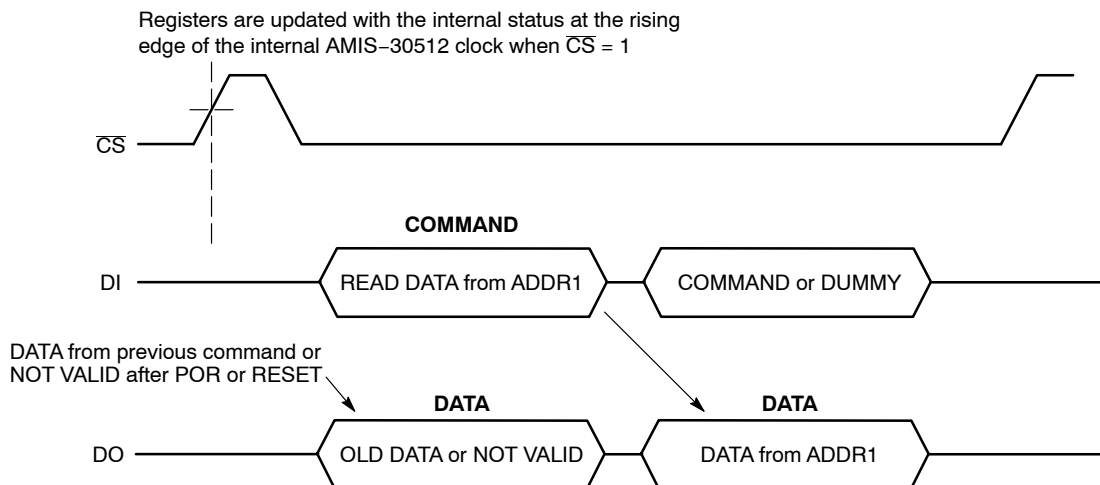

Figure 18. Single READ operation where DATA from SPI register with Address 1 is read by the Master

All 4 Status Registers (see SPI Status Registers) contain 7 data bits and a parity check bit. The most significant bit (D7) represents a parity of D[6:0]. If the number of logical ones in D[6:0] is odd, the parity bit D7 equals “1”. If the number of logical ones in D[6:0] is even then the parity bit D7 equals “0”. This simple mechanism protects against noise and increases the consistency of the transmitted data. If a parity check error occurs it is recommended to initiate an additional READ command to obtain the status again.

Also the Control Registers (see SPI Control Registers) can be read out following the same routine. Control Registers don’t have a parity check.

The CSB line is active low and may remain low between successive READ commands as illustrated in Figure 18. There is however one exception. In case an error condition is latched in one of Status Registers (see SPI Registers) the ERRB pin is activated. (See Error Output). This signal flags a problem to the external microcontroller. By reading the Status Registers information about the root cause of the problem can be determined. After this READ operation the Status Registers are cleared. Because the Status Registers and ERRB pin are only updated by the internal system clock when the CSB line is high, the Master should force CSB high

immediately after the READ operation. For the same reason it is recommended to keep the CSB line high always when the SPI bus is idle.

WRITE Operation

If the Master wants to write data to a Control Register it initiates the communication by sending a WRITE command. This contains the address of the SPI register to write to. The command is followed with a data byte. This incoming data will be stored in the corresponding Control Register after CSB goes from low to high! AMIS-30512 responds on every incoming byte by shifting out via DO the data stored in the last received address.

It is important that the writing action (command – address and data) to the Control Register is exactly 16 bits long. If more or less bits are transmitted the complete transfer packet is ignored.

A WRITE command executed for a read-only register (e.g. Status Registers) will not affect the addressed register and the device operation.

Because after a power-on-reset the initial address is unknown the data shifted out via DO is not valid.

AMIS-30512

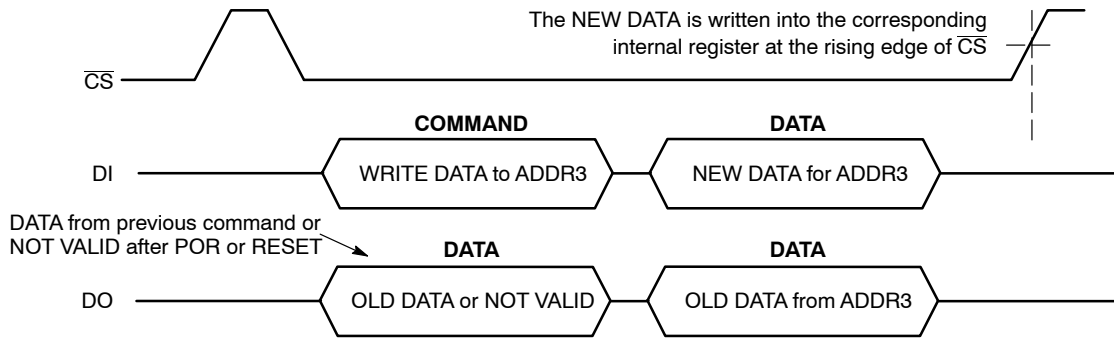

Figure 19. Single WRITE Operation where DATA from the Master is Written in SPI Register with Address 3

Examples of Combined READ and WRITE Operations

In the following examples successive READ and WRITE operations are combined. In Figure 17 the Master first reads the status from Register at ADDR4 and at ADDR5 followed

by writing a control byte in Control Register at ADDR2. Note that during the write command (in Figure 3) the old data of the pointed register is returned at the moment the new data is shifted in:

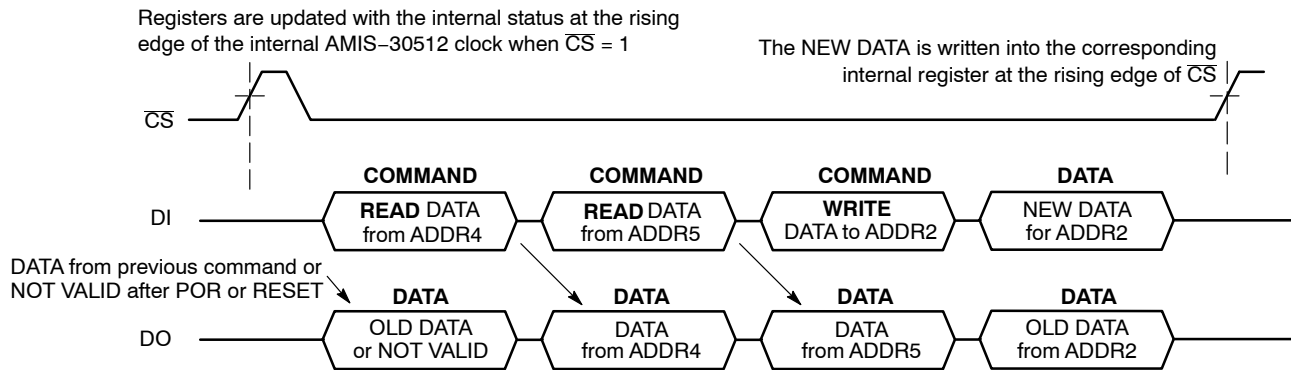

Figure 20. 2 Successive READ Commands Followed by a WRITE Command

After the write operation the Master could initiate a read back command in order to verify the data correctly written as illustrated in Figure 18. During reception of the READ command the old data is returned for a second time. Only after receiving the READ command the new data is

transmitted. This rule also applies when the master device wants to initiate an SPI transfer to read the Status Registers. Because the internal system clock updates the Status Registers only when CSB line is high, the first read out byte might represent old status information.

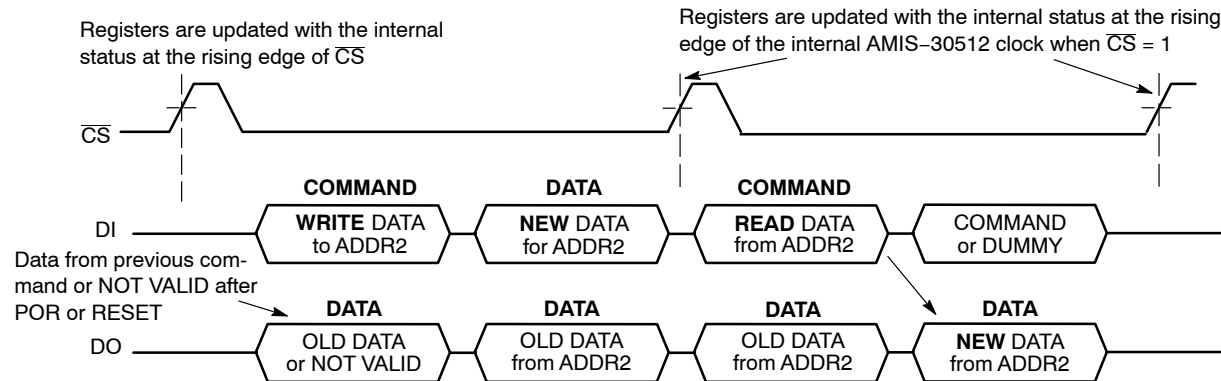

Figure 21. A WRITE Operation where DATA from the Master is Written in SPI Register with Address 2 Followed by a READ Back Operation to Confirm a Correct WRITE Operation

NOTE: The internal data-out shift buffer of AMIS-30512 is updated with the content of the selected SPI register only at the last (every eight) falling edge of the CLK signal (see SPI Transfer Format and Pin Signals). As a result, new data for transmission cannot be written to the shift buffer at the beginning of the transfer packet and the first byte shifted out might represent old data.

SPI Control Registers

All SPI control registers have Read/Write access and default to “0” after power-on or hard reset.

Table 12. SPI Control Register WR

Control Register (WR)									
Address	Content	Structure							
		Bit 7	Bit 6	Bit 5	Bit 4	Bit 3	Bit 2	Bit 1	Bit 0
00h	Access	R/W	R/W	R/W	R/W	R/W	R/W	R/W	R/W
	Reset	0	0	0	0	0	0	0	0
	Data	WDEN	WDT[3:0]				-	-	-

Where:

- R/W Read and Write access
- Reset: Status after power-On or hard reset
- WDEN: Watchdog enable. Writing “1” to this bit will activate the watchdog timer (if not enabled yet) or will clear this timer (if already enabled). Writing “0” to this bit will clear WD bit (SPI Status Register 0).
- WDT[3:0]: Watchdog timeout interval

Table 13. SPI Control Register 0

Control Register 0 (CR0)									
Address	Content	Structure							
		Bit 7	Bit 6	Bit 5	Bit 4	Bit 3	Bit 2	Bit 1	Bit 0
01h	Access	R/W	R/W	R/W	R/W	R/W	R/W	R/W	R/W
	Reset	0	0	0	0	0	0	0	0
	Data	SM[2:0]				CUR[4:0]			

Where:

- R/W Read and Write access
- Reset: Status after power-On or hard reset
- SM[2:0]: Step mode
- CUR[4:0]: Current amplitude

Table 14. SPI Control Register 1

Control Register 1 (CR1)									
Address	Content	Structure							
		Bit 7	Bit 6	Bit 5	Bit 4	Bit 3	Bit 2	Bit 1	Bit 0
02h	Access	R/W	R/W	R/W	R/W	R/W	R/W	R/W	R/W
	Reset	0	0	0	0	0	0	0	0
	Data	DIRCTRL	NXTP	-	-	PWMF	PWMJ	EMC[1:0]	

Where:

- R/W Read and Write access
- Reset: Status after power-on or hard reset
- DIRCTRL Direction control
- NXTP NEXT polarity
- PWMF PWM frequency
- PWMJ PWM jitter
- EMC[1:0] EMC slope control

Table 15. SPI Control Register 2

Control Register 2 (CR2)									
Address	Content	Structure							
		Bit 7	Bit 6	Bit 5	Bit 4	Bit 3	Bit 2	Bit 1	Bit 0
03h	Access	R/W	R/W	R/W	R/W	R/W	R/W	R/W	R/W
	Reset	0	0	0	0	0	0	0	0
	Data	MOTEN	SLP	SLAG	SLAT	-	-	-	-

Where:

R/W	Read and Write access	SLP	Sleep
Reset:	Status after power-On or hard reset	SLAG	Speed load angle gain
MOTEN	Motor enable	SLAT	Speed load angle transparency

Table 16. SPI Control Parameter Overview SLAT

Symbol	Description	Status	Behaviour
SLAT	Speed Load Angle Transparency bit	<SLAT> = 0	SLA is transparent
		<SLAT> = 1	SLA is NOT transparent

Table 17. SPI Control Parameter Overview SLAG

Symbol	Description	Status	Value
SLAG	Speed Load Angle Gain setting	<SLAG> = 0	Gain = 0.5
		<SLAG> = 1	Gain = 0.25

Table 18. SPI Control Parameter Overview PWMF

Symbol	Description	Status	Value
PWMF	Enables doubling of the PWM frequency	<PWMF> = 0	f _{PWM} = 22.8 kHz
		<PWMF> = 1	f _{PWM} = 45.6 kHz

Table 19. SPI Control Parameter Overview PWMJ

Symbol	Description	Status	Behaviour
PWMJ	Enables jittery PWM	<PWMJ> = 0	Jitter disabled
		<PWMJ> = 1	Jitter enabled

Table 20. SPI Control Parameter Overview SLP

Symbol	Description	Status	Behaviour
SLP	Enables sleep mode	<SLP> = 0	Active mode
		<SLP> = 1	Sleep mode

Table 21. SPI Control Parameter Overview MOTEN

Symbol	Description	Status	Value
MOTEN	Activates the motor driver outputs	<MOTEN> = 0	Drivers disabled
		<MOTEN> = 1	Drivers enabled

Table 22. SPI Control Parameter Overview DIRCTRL

Symbol	Description	Status		Value
DIRCTRL	Controls the direction of rotation (in combination with logic level on input DIR)	<DIR> = 0	<DIRCTRL> = 0	CW motion
			<DIRCTRL> = 1	CCW motion
		<DIR> = 1	<DIRCTRL> = 0	CCW motion
			<DIRCTRL> = 1	CW motion

Table 23. SPI Control Parameter Overview NXTP

Symbol	Description	Status	Value
NXTP	Selects if NXT triggers on rising or falling edge	<NXTP> = 0	Trigger on rising edge
		<NXTP> = 1	Trigger on falling edge

CUR[4:0] Selects IMCmax peak. This is the peak or amplitude of the regulated current waveform in the motor coils.

Table 24. SPI Control Parameter Overview CUR[4:0]

Index	CUR[4:0]					Current (mA)	Index	CUR[4:0]					Current (mA)
0	0	0	0	0	0	15	10	1	0	0	0	0	181
1	0	0	0	0	1	30	11	1	0	0	0	1	200
2	0	0	0	1	0	45	12	1	0	0	1	0	221
3	0	0	0	1	1	50	13	1	0	0	1	1	244
4	0	0	1	0	0	55	14	1	0	1	0	0	269
5	0	0	1	0	1	61	15	1	0	1	0	1	297
6	0	0	1	1	0	67	16	1	0	1	1	0	328
7	0	0	1	1	1	74	17	1	0	1	1	1	362
8	0	1	0	0	0	82	18	1	1	0	0	0	400
9	0	1	0	0	1	91	19	1	1	0	0	1	441
A	0	1	0	1	0	100	1A	1	1	0	1	0	487
B	0	1	0	1	1	110	1B	1	1	0	1	1	538
C	0	1	1	0	0	122	1C	1	1	1	0	0	594
D	0	1	1	0	1	135	1D	1	1	1	0	1	656
E	0	1	1	1	0	149	1E	1	1	1	1	0	724
F	0	1	1	1	1	164	1F	1	1	1	1	1	800

EMC[1:0] Adjusts the dV/dt of the PWM voltage slopes on the motor pins.

Table 25. SPI Control Parameter Overview EMC[1:0]

Index	EMC[1:0]		Slope (V/ μ s)	Remark
0	0	0	150	Turn-on and turn-off voltage slope 10% to 90%
1	0	1	100	"
2	1	0	50	"
3	1	1	25	"

SM[2:0] Selects the micro-stepping mode.

Table 26. SPI Control Parameter Overview SM[2:0]

Index	SM[2:0]			Step Mode	Remark
0	0	0	0	1/32	Micro-step
1	0	0	1	1/16	Micro-step
2	0	1	0	1/8	Micro-step
3	0	1	1	1/4	Micro-step
4	1	0	0	1/2	Uncompensated half-step
5	1	0	1	1/2	Compensated half-step
6	1	1	0	Full	Full step
7	1	1	1	N/A	For future use

SPI Status Register Description

All four SPI status registers have Read Access and are default to “0” after power-on or hard reset.

Table 27. Status Register 0 (SR0)

Address	Content	Structure							
		Bit 7	Bit 6	Bit 5	Bit 4	Bit 3	Bit 2	Bit 1	Bit 0
04h	Access	R	R	R	R	R	R	R	R
	Reset	0	0	0	0	0	0	0	0
	Data	PAR	TW	CPfail	-	OPENX	OPENY	-	-

Where:

- R Read only mode access
- Reset Status after power-on or hard reset
- PAR Parity check
- TW Thermal warning
- CPfail Charge pump failure
- OPENX Open Coil X detected
- OPENY Open Coil Y detected

Remark: Data is **not** latched

Table 28. Status Register 1 (SR1)

Address	Content	Structure							
		Bit 7	Bit 6	Bit 5	Bit 4	Bit 3	Bit 2	Bit 1	Bit 0
05h	Access	R	R	R	R	R	R	R	R
	Reset	0	0	0	0	0	0	0	0
	Data	PAR	OVCXPT	OVCXPB	OVCXNT	OVCXNB	-	-	-

Where:

- R Read only mode access
- Reset Status after power-on or hard reset
- PAR Parity check
- OVCXPT Over-current detected on X H-bridge: MOTXP terminal, top transistor
- OVCXPB Over-current detected on X H-bridge: MOTXP terminal, bottom transistor
- OVCXNT Over-current detected on X H-bridge: MOTXN terminal, top transistor
- OVCXNB Over-current detected on X H-bridge: MOTXN terminal, bottom transistor

Remark: Data is latched

Table 29. SPI Status Register 2 (SR2)

Address	Content	Structure							
		Bit 7	Bit 6	Bit 5	Bit 4	Bit 3	Bit 2	Bit 1	Bit 0
06h	Access	R	R	R	R	R	R	R	R
	Reset	0	0	0	0	0	0	0	0
	Data	PAR	OVCYPT	OVCYPB	OVCYNT	OVCYNB	TSD	-	-

Where:

- R Read only mode access
- Reset Status after power-on or hard reset
- PAR Parity check
- OVCYPT Over-current detected on Y H-bridge: MOTYP terminal, top transistor
- OVCYPB Over-current detected on Y H-bridge: MOTYP terminal, bottom transistor
- OVCYNT Over-current detected on Y H-bridge: MOTYN terminal, top transistor
- OVCYNB Over-current detected on Y H-bridge: MOTYN terminal, bottom transistor
- TSD Thermal shutdown

Remark: Data is latched

Table 30. SPI Status Register 3 (SR3)

Address	Content	Structure							
		Bit 7	Bit 6	Bit 5	Bit 4	Bit 3	Bit 2	Bit 1	Bit 0
07h	Access	R	R	R	R	R	R	R	R
	Reset	0	0	0	0	0	0	0	0
	Data	PAR	MSP[6:0]						

Where:

- R Read only mode access
- Reset Status after power-on or hard reset
- PAR Parity check
- MSP[6:0] Translator micro-step position

Remark: Data is **not** latched

Table 31. SPI Status Flags Overview

Flag	Mnemonic	Length (bit)	Related SPI Register	Comment	Reset State
Charge pump failure	CPFail	1	Status Register 0	'0' = no failure '1' = failure: indicates that the charge pump does not reach the required voltage level.	'0'
Micro-step position	MSP [6:0]	7	Status Register 3	Translator micro-step position	'0000000'
OPEN Coil X	OPENX	1	Status Register 0	'1' = Open coil detected	'0'
OPEN Coil Y	OPENY	1	Status Register 0	'1' = Open coil detected	'0'
Over Current on X H-bridge; MOTXN terminal; Bottom tran.	OVCXNB	1	Status Register 1	'0' = no failure '1' = failure: indicates that over current is detected at bottom transistor XN-terminal	'0'
Over Current on X H-bridge; MOTXN terminal; Top tran.	OVCXNT	1	Status Register 1	'0' = no failure '1' = failure: indicates that over current is detected at top transistor XN-terminal	'0'
Over Current on X H-bridge; MOTXP terminal; Bottom tran.	OVCXPB	1	Status Register 1	'0' = no failure '1' = failure: indicates that over current is detected at bottom transistor XP-terminal	'0'
Over Current on X H-bridge; MOTXP terminal; Top tran.	OVCXPT	1	Status Register 1	'0' = no failure '1' = failure: indicates that over current is detected at top transistor XP-terminal	'0'
Over Current on Y H-bridge; MOTYN terminal; Bottom tran.	OVCYNB	1	Status Register 2	'0' = no failure '1' = failure: indicates that over current is detected at bottom transistor YN-terminal	'0'
Over Current on Y H-bridge; MOTYN terminal; Top tran.	OVCYNT	1	Status Register 2	'0' = no failure '1' = failure: indicates that over current is detected at top transistor YN-terminal	'0'
Over Current on Y H-bridge; MOTYP terminal; Bottom tran.	OVCYPB	1	Status Register 2	'0' = no failure '1' = failure: indicates that over current is detected at bottom transistor YP-terminal	'0'
Over Current on Y H-bridge; MOTYP terminal; Top tran.	OVCYPT	1	Status Register 2	'0' = no failure '1' = failure: indicates that over current is detected at top transistor YP-terminal	'0'
Thermal shutdown	TSD	1	Status Register 2		'0'
Thermal warning	TW	1	Status Register 0		'0'
Watchdog event	WD	1	Status Register 0	'1' = watchdog reset after time-out	'0'

Soldering

Introduction to Soldering Surface Mount Packages

This text gives a very brief insight to a complex technology. A more in-depth account of soldering ICs can be found in the AMIS “Data Handbook IC26; Integrated Circuit Packages” (document order number 9398 652 90011). There is no soldering method that is ideal for all surface mount IC packages. Wave soldering is not always suitable for surface mount ICs, or for printed-circuit boards (PCB) with high population densities. In these situations re-flow soldering is often used.

Re-flow Soldering

Re-flow soldering requires solder paste (a suspension of fine solder particles, flux and binding agent) to be applied to the PCB by screen printing, stencilling or pressure-syringe dispensing before package placement. Several methods exist for re-flowing; for example, infrared/convection heating in a conveyor type oven.

Throughput times (preheating, soldering and cooling) vary between 100 and 200 seconds depending on the heating method. Typical re-flow peak temperatures range from 215 to 260°C. The top-surface temperature of the packages should preferably be kept below 230°C.

Wave Soldering

Conventional single wave soldering is not recommended for surface mount devices (SMDs) or PCBs with a high component density, as solder bridging and non-wetting can present major problems. To overcome these problems, the double-wave soldering method was specifically developed.

If wave soldering is used the following conditions must be observed for optimal results:

- Use a double-wave soldering method comprising a turbulent wave with high upward pressure followed by a smooth laminar wave.
- For packages with leads on two sides and a pitch (e):
 1. Larger than or equal to 1.27 mm, the footprint longitudinal axis is preferred to be parallel to the transport direction of the PCB;
 2. Smaller than 1.27 mm, the footprint longitudinal axis must be parallel to the transport direction of the PCB. The footprint must incorporate solder thieves at the downstream end.
- For packages with leads on four sides, the footprint must be placed at a 45° angle to the transport direction of the PCB. The footprint must incorporate solder thieves downstream and at the side corners.

During placement and before soldering, the package must be fixed with a droplet of adhesive. The adhesive can be applied by screen printing, pin transfer or syringe dispensing. The package can be soldered after the adhesive is cured. Typical dwell time is four seconds at 250°C. A mildly-activated flux will eliminate the need for removal of corrosive residues in most applications.

Manual Soldering

Fix the component by first soldering two diagonally-opposite end leads. Use a low voltage (24 V or less) soldering iron applied to the flat part of the lead. Contact time must be limited to 10 seconds at up to 300°C.

When using a dedicated tool, all other leads can be soldered in one operation within two to five seconds between 270 and 320°C.

Table 32. Soldering Process

Package	Soldering Method	
	Wave	Re-flow (Note 7)
BGA, SQFP	Not suitable	Suitable
HLQFP, HSQFP, HSOP, HTSSOP, SMS	Not suitable (Note 8)	Suitable
PLCC (Note 9) , SO, SOJ	Suitable	Suitable
LQFP, QFP, TQFP	Not recommended (Notes 9 and 10)	Suitable
SSOP, TSSOP, VSO	Not recommended (Note 11)	Suitable

7. All surface mount (SMD) packages are moisture sensitive. Depending upon the moisture content, the maximum temperature (with respect to time) and body size of the package, there is a risk that internal or external package cracks may occur due to vaporization of the moisture in them (the so called popcorn effect). For details, refer to the drypack information in the “Data Handbook IC26; Integrated Circuit Packages; Section: Packing Methods.”
8. These packages are not suitable for wave soldering as a solder joint between the PCB and heatsink (at bottom version) can not be achieved, and as solder may stick to the heatsink (on top version).
9. If wave soldering is considered, then the package must be placed at a 45° angle to the solder wave direction. The package footprint must incorporate solder thieves downstream and at the side corners.
10. Wave soldering is only suitable for LQFP, TQFP and QFP packages with a pitch (e) equal to or larger than 0.8 mm; it is definitely not suitable for packages with a pitch (e) equal to or smaller than 0.65 mm.
11. Wave soldering is only suitable for SSOP and TSSOP packages with a pitch (e) equal to or larger than 0.65 mm; it is definitely not suitable for packages with a pitch (e) equal to or smaller than 0.5 mm.

AMIS-30512

PACKAGE DIMENSIONS

24 LEAD SOIC
CASE 751AW
ISSUE O

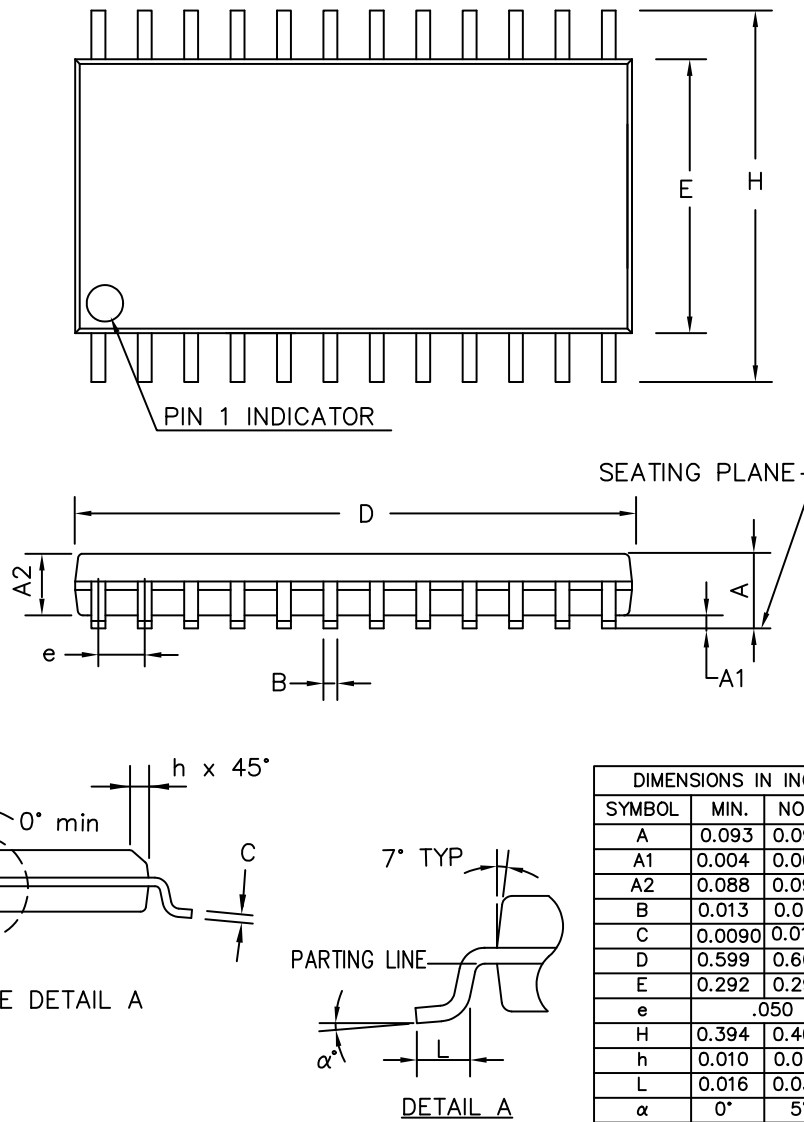

ON Semiconductor and are registered trademarks of Semiconductor Components Industries, LLC (SCILLC). SCILLC reserves the right to make changes without further notice to any products herein. SCILLC makes no warranty, representation or guarantee regarding the suitability of its products for any particular purpose, nor does SCILLC assume any liability arising out of the application or use of any product or circuit, and specifically disclaims any and all liability, including without limitation special, consequential or incidental damages. "Typical" parameters which may be provided in SCILLC data sheets and/or specifications can and do vary in different applications and actual performance may vary over time. All operating parameters, including "Typicals" must be validated for each customer application by customer's technical experts. SCILLC does not convey any license under its patent rights nor the rights of others. SCILLC products are not designed, intended, or authorized for use as components in systems intended for surgical implant into the body, or other applications intended to support or sustain life, or for any other application in which the failure of the SCILLC product could create a situation where personal injury or death may occur. Should Buyer purchase or use SCILLC products for any such unintended or unauthorized application, Buyer shall indemnify and hold SCILLC and its officers, employees, subsidiaries, affiliates, and distributors harmless against all claims, costs, damages, and expenses, and reasonable attorney fees arising out of, directly or indirectly, any claim of personal injury or death associated with such unintended or unauthorized use, even if such claim alleges that SCILLC was negligent regarding the design or manufacture of the part. SCILLC is an Equal Opportunity/Affirmative Action Employer. This literature is subject to all applicable copyright laws and is not for resale in any manner.

PUBLICATION ORDERING INFORMATION

LITERATURE FULFILLMENT:
Literature Distribution Center for ON Semiconductor
P.O. Box 5163, Denver, Colorado 80217 USA
Phone: 303-675-2175 or 800-344-3860 Toll Free USA/Canada
Fax: 303-675-2176 or 800-344-3867 Toll Free USA/Canada
Email: orderlit@onsemi.com

N. American Technical Support: 800-282-9855 Toll Free
USA/Canada
Europe, Middle East and Africa Technical Support:
Phone: 421 33 790 2910
Japan Customer Focus Center
Phone: 81-3-5773-3850

ON Semiconductor Website: www.onsemi.com
Order Literature: <http://www.onsemi.com/orderlit>
For additional information, please contact your local Sales Representative

Компания «Life Electronics» занимается поставками электронных компонентов импортного и отечественного производства от производителей и со складов крупных дистрибьюторов Европы, Америки и Азии.

С конца 2013 года компания активно расширяет линейку поставок компонентов по направлению коаксиальный кабель, кварцевые генераторы и конденсаторы (керамические, пленочные, электролитические), за счёт заключения дистрибьюторских договоров

Мы предлагаем:

- Конкурентоспособные цены и скидки постоянным клиентам.
- Специальные условия для постоянных клиентов.
- Подбор аналогов.
- Поставку компонентов в любых объемах, удовлетворяющих вашим потребностям.
- Приемлемые сроки поставки, возможна ускоренная поставка.
- Доставку товара в любую точку России и стран СНГ.
- Комплексную поставку.
- Работу по проектам и поставку образцов.
- Формирование склада под заказчика.
- Сертификаты соответствия на поставляемую продукцию (по желанию клиента).
- Тестирование поставляемой продукции.
- Поставку компонентов, требующих военную и космическую приемку.
- Входной контроль качества.
- Наличие сертификата ISO.

В составе нашей компании организован Конструкторский отдел, призванный помогать разработчикам, и инженерам.

Конструкторский отдел помогает осуществить:

- Регистрацию проекта у производителя компонентов.
- Техническую поддержку проекта.
- Защиту от снятия компонента с производства.
- Оценку стоимости проекта по компонентам.
- Изготовление тестовой платы монтаж и пусконаладочные работы.



Тел: +7 (812) 336 43 04 (многоканальный)
Email: org@lifeelectronics.ru