



Main

Range of product	OsiSense XU
Series name	Application material handling
Electronic sensor type	Photo-electric sensor
Sensor name	XUE
Sensor design	Compact 90 x 90
Detection system	Diffuse
Material	Plastic
Supply circuit type	DC
Wiring technique	5-wire
Discrete output type	PNP
Discrete output function	2 NO/NC programmable
Analogue output range	4...20 mA
Electrical connection	1 male connector M12, 5 pins
Product specific application	Distance measurement on object
Emission	Infrared laser, pulsed (class 1), wavelength: 3.563E-05 in (905 nm) conforming to IEC 600825-1 Red laser, pulsed (class 2), wavelength: 2.6378E-05 in (670 nm) conforming to IEC 600825-1
[Sn] nominal sensing distance	19.69 ft (6 m)

Complementary

Enclosure material	ABS, anti-shock
Lens material	PMMA
Linearity	<= +/- 40 mm
Spot dimension	4 x 12 mm at 6 meters
Status LED	1 LED (green) supply on 2 LEDs (yellow) output 4 LEDs (red) parametering 1 LED (orange) slow mode
[Us] rated supply voltage	24 V DC with reverse polarity protection
Supply voltage limits	18...30 V DC
Switching capacity in mA	100 mA (overload and short-circuit protection)
Switching time	13 ms fast mode 80 ms slow mode
Voltage drop	<= 2.4 V (closed state)
Current consumption	125 mA (no-load)
Delay first up	13 ms 80 ms
Delay response	13 ms fast mode 80 ms slow mode
Setting-up	Parametering by buttons
Height	3.66 in (93 mm)
Length	3.74 in (95 mm)
Width	1.65 in (42 mm)
Product weight	0.44 lb(US) (0.2 kg)

Environment

product certifications	CE CULus
ambient air temperature for operation	14...122 °F (-10...50 °C)

The information provided in this documentation contains general descriptions and/or technical characteristics of the performance of the products contained herein. This documentation is not intended as a substitute for and is not to be used for determining suitability or reliability of these products for specific user applications. It is the duty of any such user or integrator to perform the appropriate and complete risk analysis, evaluation and testing of the products with respect to the relevant specific application or use thereof. Neither Schneider Electric Industries SAS nor any of its affiliates or subsidiaries shall be responsible or liable for misuse of the information contained herein.

ambient air temperature for storage	-40...176 °F (-40...80 °C)
vibration resistance	7 gn, amplitude = +/- 0.5 mm (f = 10...55 Hz) conforming to IEC 60947-5-2
shock resistance	30 gn (duration = 11 ms) conforming to IEC 60947-5-2
IP degree of protection	IP67 conforming to IEC 60529

Offer Sustainability

Not Green Premium product	Not Green Premium product
Will not be Compliant	Will not be Compliant
WARNING: This product can expose you to chemicals including:	WARNING: This product can expose you to chemicals including:
Diisononyl phthalate (DINP), which is known to the State of California to cause cancer, and	Diisononyl phthalate (DINP), which is known to the State of California to cause cancer, and
Di-isodecyl phthalate (DIDP), which is known to the State of California to cause birth defects or other reproductive harm.	Di-isodecyl phthalate (DIDP), which is known to the State of California to cause birth defects or other reproductive harm.
For more information go to www.p65warnings.ca.gov	For more information go to www.p65warnings.ca.gov

Contractual warranty

Warranty period	18 months
-----------------	-----------

Dimensions

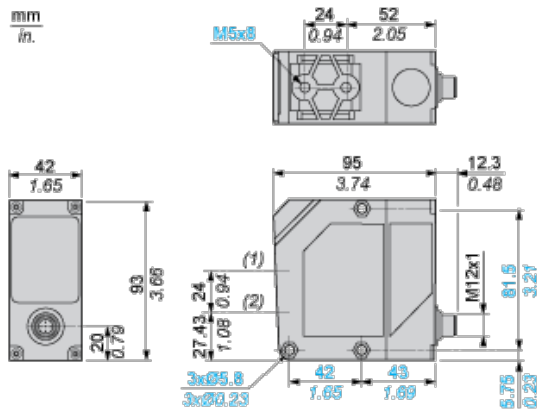

- (1) Receiver optical axis
- (2) Transmitter optical axis

Dimensions with Fixing Bracket XUZA618

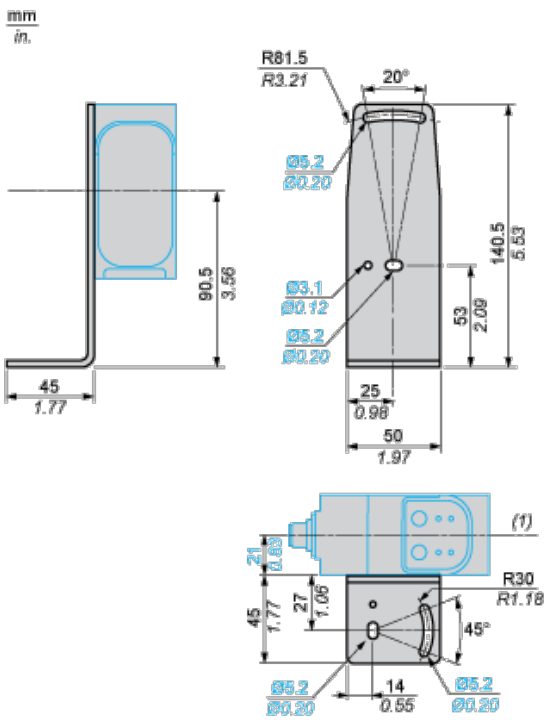

(1) Optical axis

Wiring Schemes

M12 Connector

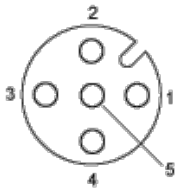

- 1: + U_B
- 2: Q_B
- 3: - U_B
- 4: Q_A
- 5: 4...20mA

Output

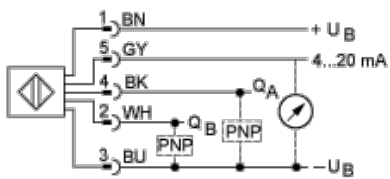

- BN : Brown
- WH :White
- BU : Blue
- BK : Black
- GY : Grey

Curves

Minimum Size of Detectable Object Related to Distance

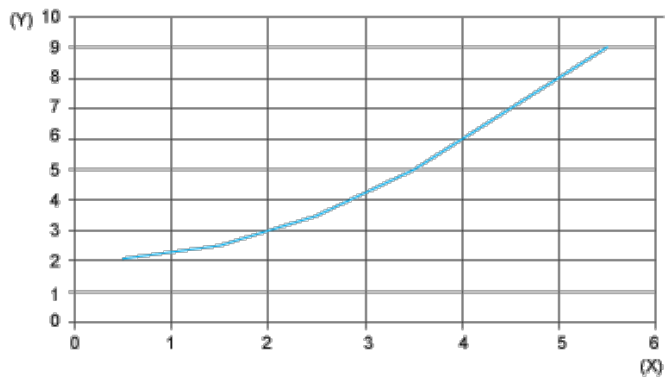

- (y) Length of object (mm)
- (x) Distance (m)

Curves

Light Spot Size (Not Visible)

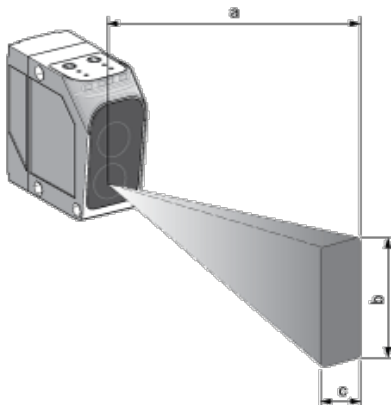

a (m)	b (mm)	c (mm)
0	10	5
2	7	4
4	10	3
6	12	4

Компания «Life Electronics» занимается поставками электронных компонентов импортного и отечественного производства от производителей и со складов крупных дистрибьюторов Европы, Америки и Азии.

С конца 2013 года компания активно расширяет линейку поставок компонентов по направлению коаксиальный кабель, кварцевые генераторы и конденсаторы (керамические, пленочные, электролитические), за счёт заключения дистрибьюторских договоров

Мы предлагаем:

- Конкурентоспособные цены и скидки постоянным клиентам.
- Специальные условия для постоянных клиентов.
- Подбор аналогов.
- Поставку компонентов в любых объемах, удовлетворяющих вашим потребностям.
- Приемлемые сроки поставки, возможна ускоренная поставка.
- Доставку товара в любую точку России и стран СНГ.
- Комплексную поставку.
- Работу по проектам и поставку образцов.
- Формирование склада под заказчика.
- Сертификаты соответствия на поставляемую продукцию (по желанию клиента).
- Тестирование поставляемой продукции.
- Поставку компонентов, требующих военную и космическую приемку.
- Входной контроль качества.
- Наличие сертификата ISO.

В составе нашей компании организован Конструкторский отдел, призванный помогать разработчикам, и инженерам.

Конструкторский отдел помогает осуществить:

- Регистрацию проекта у производителя компонентов.
- Техническую поддержку проекта.
- Защиту от снятия компонента с производства.
- Оценку стоимости проекта по компонентам.
- Изготовление тестовой платы монтаж и пусконаладочные работы.



Тел: +7 (812) 336 43 04 (многоканальный)

Email: org@lifeelectronics.ru