

NCP1080

Integrated PoE-PD & DC-DC Converter Controller

Introduction

The NCP1080 is a member of ON Semiconductor's Power over Ethernet Powered Device (PoE-PD) product family and represents a robust, flexible and highly integrated solution targeting demanding Ethernet applications. It combines in a single unit an enhanced PoE-PD interface fully supporting the IEEE802.3af specification and a flexible and configurable DC-DC converter controller.

The NCP1080's exceptional capabilities offer new opportunities for the design of products powered directly over Ethernet lines, eliminating the need for local power adaptors or power supplies and drastically reducing the overall installation and maintenance cost.

ON Semiconductor's unique manufacturing process and design enhancements allow the NCP1080 to deliver up to 13 W of regulated power to support PoE applications according to the IEEE802.3af standard. This device leverages the significant cost advantages of PoE-enabled systems to a broad spectrum of products in markets such as VoIP phones, wireless LAN access point, security cameras, point of sales terminals, RFID readers, industrial ethernet devices, etc.

The integrated current mode DC-DC controller facilitates isolated and non-isolated fly-back, forward and buck converter topologies. It has all the features necessary for a flexible, robust and highly efficient design including programmable switching frequency, duty cycle up to 80 percent, slope compensation, and soft start-up.

The NCP1080 is fabricated in a robust high voltage process and integrates a rugged vertical N-channel DMOS with a low loss current sense technique suitable for the most demanding environments and capable of withstanding harsh environments such as hot swap and cable ESD events.

The NCP1080 complements ON Semiconductor's ASSP portfolio in communications and industrial devices and can be combined with other high-voltage interfacing devices to offer complete solutions to the communication, industrial and security markets.

Features

Powered Device Interface

- Fully Supports IEEE802.3af Standard
- Regulated Power Output up to 13 W
- Programmable Classification Current
- Adjustable Under Voltage Lock Out
- Programmable Inrush Current Limit
- Programmable Operational Current Limit up to 500 mA
- Over-temperature Protection
- Industrial Temperature Range -40°C to 85°C with Full Operation up to 150°C Junction Temperature
- 0.6 Ohm Hot-swap Pass-switch with Low Loss Current Sense Technique

- Vertical N-channel DMOS Pass-switch Offers the Robustness of Discrete MOSFETs with Integrated Temperature Control

DC-DC Converter Controller

- Current Mode Control
- Supports Isolated and Non-isolated DC-DC Converter Applications
- Internal Voltage Regulators
- Wide Duty Cycle Range with Internal Slope Compensation Circuitry
- Programmable Oscillator Frequency
- Programmable Soft-start Time



ON Semiconductor®

<http://onsemi.com>

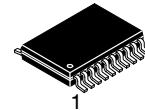

TSSOP-20 EP
DE SUFFIX
CASE 948AB

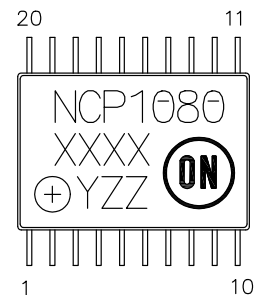

NCP1080 = Specific Device Code
XXXX = Date Code
Y = Assembly Location
ZZ = Traceability Code

ORDERING INFORMATION

See detailed ordering and shipping information in the package dimensions section on page 2 of this data sheet.

NCP1080

PIN DIAGRAM

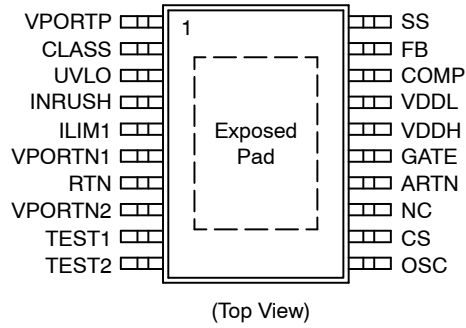

Ordering Information

| Part Number | Package | Shipping Configuration† | Temperature Range |
|--------------|--------------------------|-------------------------|-------------------|
| NCP1080DEG | TSSOP-20 EP (Pb-Free) | 74 units / Tube | -40°C to 85°C |
| NCP1080DER2G | TSSOP-20 EP (Pb-Free) | 2500 / Tape & Reel | -40°C to 85°C |

†For information on tape and reel specifications, including part orientation and tape sizes, please refer to our Tape and Reel Packaging Specification Brochure, BRD8011/D.

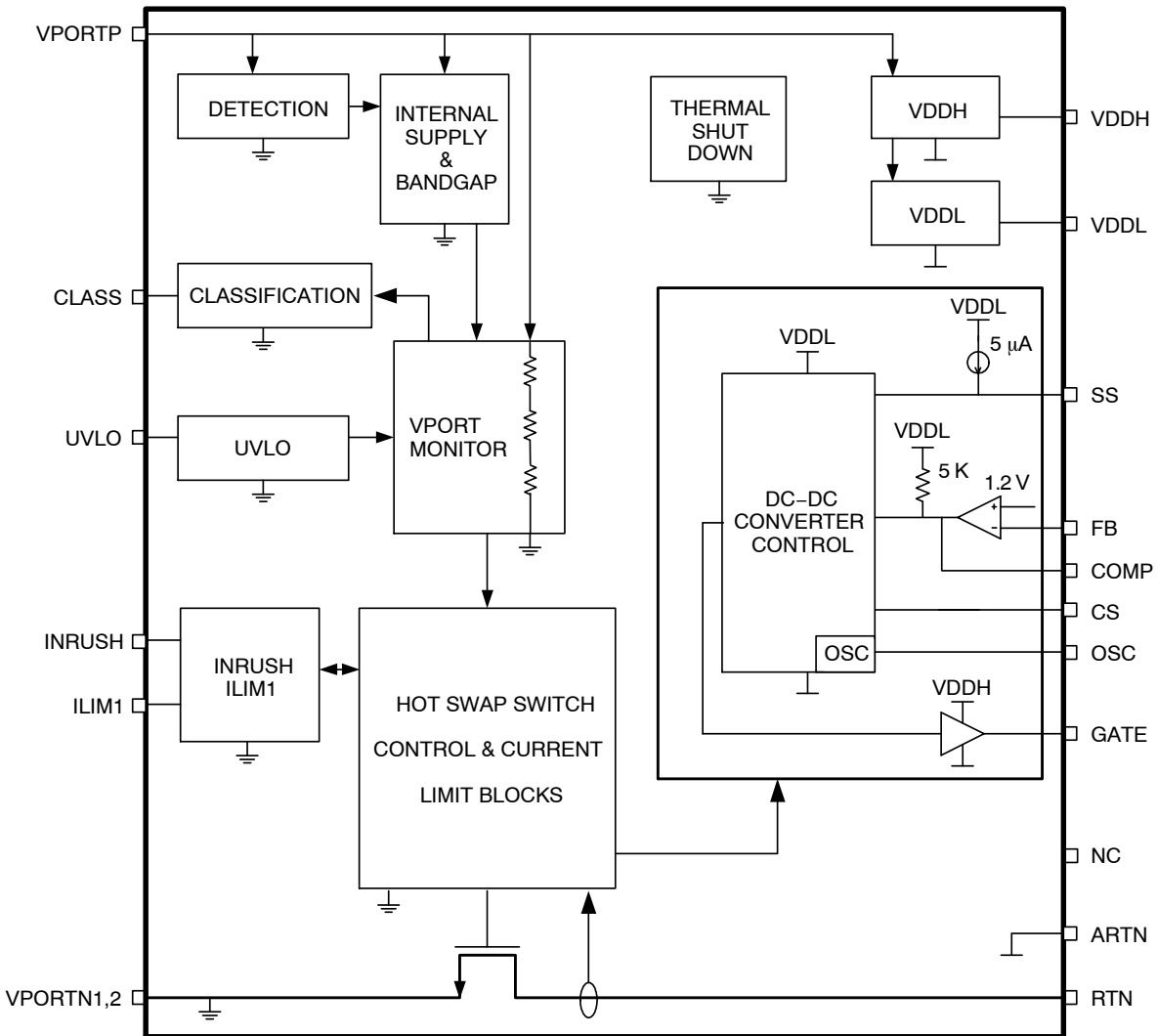

Figure 1. NCP1080 Block Diagram

Simplified Application Diagrams

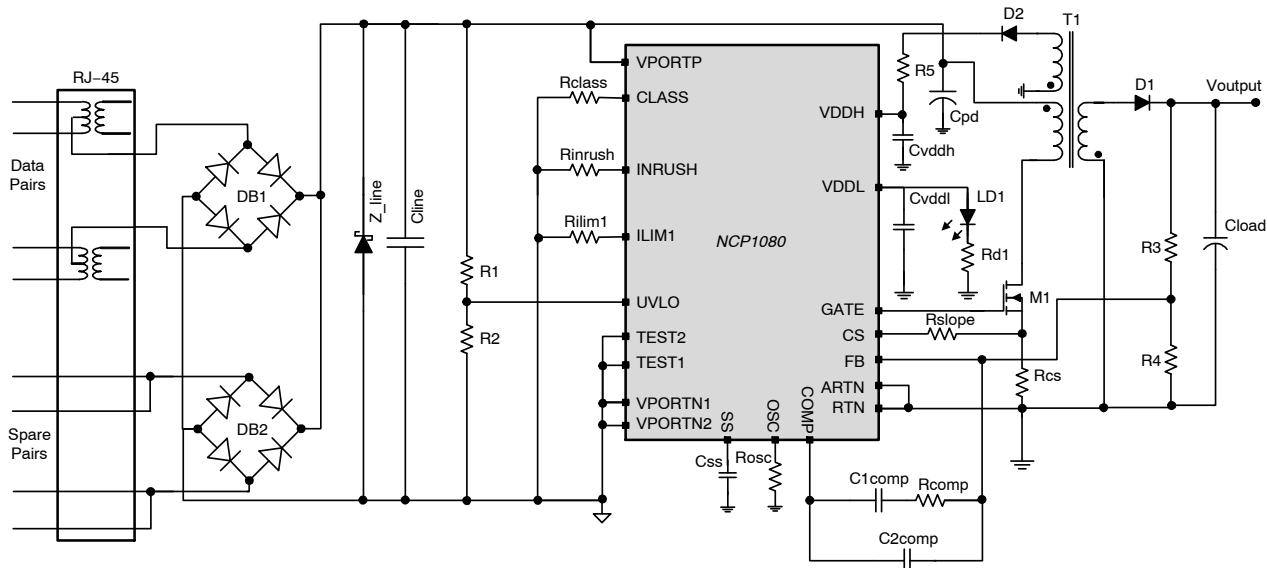

Figure 4. Non-Isolated Fly-back with Extra Winding

Figure 4 shows the same non-isolated fly-back configuration as Figure 3, but adds a 12 V auxiliary bias winding on the transformer to provide power to the NCP1080 DC-DC controller via its VDDH pin. This topology shuts off the current flowing from VPORTP to VDDH and therefore reduces the internal power dissipation of the PD, resulting in higher overall power efficiency.

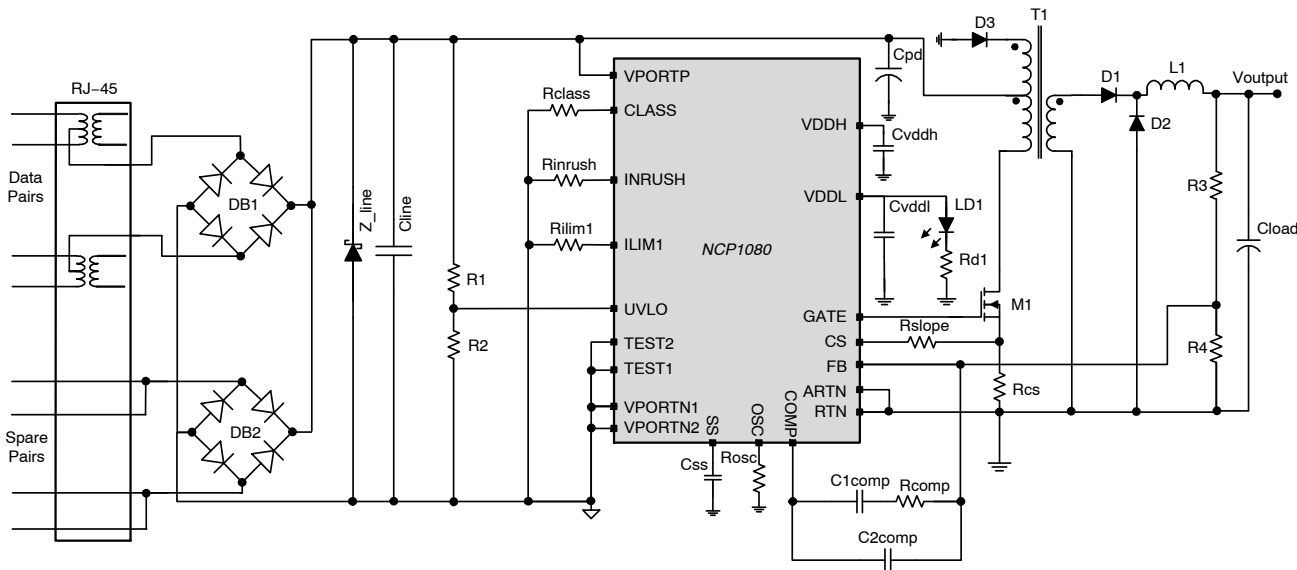

Figure 5. Non-Isolated Forward Converter

Figure 5 shows the NCP1080 used in a non-isolated forward topology.

NCP1080

Table 1. Pin Descriptions

| Name | Pin No. | Type | Description |
|--------------------|---------|--------|---|
| VPORTP | 1 | Supply | Positive input power. Voltage with respect to VPORTN _{1,2} |
| VPORTN1 VPORTN2 | 6,8 | Ground | Negative input power. Connected to the source of the internal pass-switch. |
| RTN | 7 | Ground | DC-DC controller power return. Connected to the drain of the internal pass-switch. It must be connected to ARTN. This pin is also the drain of the internal pass-switch. |
| ARTN | 14 | Ground | DC-DC controller ground pin. Must be connected to RTN as a single point ground connection for improved noise immunity. |
| VDDH | 16 | Supply | Output of the 9 V LDO internal regulator. Voltage with respect to ARTN. Supplies the internal gate driver. VDDH must be bypassed to ARTN with a 1 μ F or 2.2 μ F ceramic capacitor with low ESR. |
| VDDL | 17 | Supply | Output of the 3.3 V LDO internal regulator. Voltage with respect to ARTN. This pin can be used to bias an external low-power LED (1 mA max.) connected to ARTN, and can also be used to add extra biasing current in the external opto-coupler. VDDL must be bypassed to ARTN with a 330 nF or 470 nF ceramic capacitor with low ESR. |
| CLASS | 2 | Input | Classification current programming pin. Connect a resistor between CLASS and VPORTN _{1,2} . |
| INRUSH | 4 | Input | Inrush current limit programming pin. Connect a resistor between INRUSH and VPORTN _{1,2} . |
| ILIM1 | 5 | Input | Operational current limit programming pin. Connect a resistor between ILIM1 and VPORTN _{1,2} . |
| UVLO | 3 | Input | DC-DC controller under-voltage lockout input. Voltage with respect to VPORTN _{1,2} . Connect a resistor-divider from VPORTP to UVLO to VPORTN _{1,2} to set an external UVLO threshold. |
| GATE | 15 | Output | DC-DC controller gate driver output pin. |
| OSC | 11 | Input | Internal oscillator frequency programming pin. Connect a resistor between OSC and ARTN. |
| NC | 13 | | No connect pin, must not be connected. |
| COMP | 18 | I/O | Output of the internal error amplifier of the DC-DC controller. COMP is pulled-up internally to VDDL with a 5 k Ω resistor. In isolated applications, COMP is connected to the collector of the opto-coupler. Voltage with respect to ARTN. |
| FB | 19 | Input | DC-DC controller inverting input of the internal error amplifier. In isolated applications, the pin should be strapped to ARTN to disable the internal error amplifier. |
| CS | 12 | Input | Current-sense input for the DC-DC controller. Voltage with respect to ARTN. |
| SS | 20 | Input | Soft-start input for the DC-DC controller. A capacitor between SS and ARTN determines the soft-start timing. |
| TEST1 | 9 | Input | Digital test pin must always be connected to VPORTN _{1,2} . |
| TEST2 | 10 | Input | Digital test pin must always be connected to VPORTN _{1,2} . |
| EP | | | Exposed pad. Connected to VPORTN _{1,2} ground. |

NCP1080

Table 2. Absolute Maximum Ratings

| Symbol | Parameter | Min. | Max. | Units | Conditions |
|---------------------|---|------|------|-------|--|
| VPORTP | Input power supply | -0.3 | 72 | V | Voltage with respect to VPORTN _{1,2} |
| RTN ARTN | Analog ground supply 2 | -0.3 | 72 | V | Pass-switch in off-state (Voltage with respect to VPORTN _{1,2}) |
| VDDH | Internal regulator output | -0.3 | 17 | V | Voltage with respect to ARTN |
| VDDL | Internal regulator output | -0.3 | 3.6 | V | Voltage with respect to ARTN |
| CLASS | Analog output | -0.3 | 3.6 | V | Voltage with respect to VPORTN _{1,2} |
| INRUSH | Analog output | -0.3 | 3.6 | V | Voltage with respect to VPORTN _{1,2} |
| ILIM1 | Analog output | -0.3 | 3.6 | V | Voltage with respect to VPORTN _{1,2} |
| UVLO | Analog input | -0.3 | 3.6 | V | Voltage with respect to VPORTN _{1,2} |
| OSC | Analog output | -0.3 | 3.6 | V | Voltage with respect to ARTN |
| COMP | Analog input / output | -0.3 | 3.6 | V | Voltage with respect to ARTN |
| FB | Analog input | -0.3 | 3.6 | V | Voltage with respect to ARTN |
| CS | Analog input | -0.3 | 3.6 | V | Voltage with respect to ARTN |
| SS | Analog input | -0.3 | 3.6 | V | Voltage with respect to ARTN |
| NC | Open pin | | | | |
| TEST1 TEST2 | Digital inputs | -0.3 | 3.6 | V | Voltage with respect to VPORTN _{1,2} |
| T _a | Ambient temperature | -40 | 85 | °C | |
| T _j | Junction temperature | - | 150 | °C | |
| T _j -TSD | Junction temperature (Note 1) | - | 175 | °C | Thermal shutdown condition |
| T _{stg} | Storage Temperature | -55 | 150 | °C | |
| T _{θJA} | Thermal Resistance, Junction to Air (Note 2) | | 37.6 | °C/W | Exposed pad connected to VPORTN _{1,2} ground |
| ESD-HBM | Human Body Model | 3.5 | - | kV | per MIL-STD-883, Method 3015 |
| ESD-CDM | Charged Device Model | 750 | - | V | |
| ESD-MM | Machine Model | 300 | - | V | |
| LU | Latch-up | ±200 | - | mA | per JEDEC Standard JESD78 |
| ESD-SYS | System ESD (contact/air) (Note 3) | 8/15 | - | kV | |

Stresses exceeding Maximum Ratings may damage the device. Maximum Ratings are stress ratings only. Functional operation above the Recommended Operating Conditions is not implied. Extended exposure to stresses above the Recommended Operating Conditions may affect device reliability.

1. T_j-TSD allowed during error conditions only. It is assumed that this maximum temperature condition does not occur more than 1 hour cumulative during the useful life for reliability reasons.
2. Mounted on a 1S2P (3 layer) test board with copper coverage of 25 percent for the signal layers and 90 percent copper coverage for the inner planes at an ambient temperature of 85°C in still air. Refer to JEDEC JESD51-7 for details.
3. Surges per EN61000-4-2, 1999 applied between RJ-45 and output ground and between adapter input and output ground of the evaluation board. The specified values are the test levels and not the failure levels.

NCP1080

Recommended Operating Conditions

Operating conditions define the limits for functional operation and parametric characteristics of the device. Note that the functionality of the device outside the operating conditions described in this section is not warranted. Operating outside the recommended operating conditions for extended periods of time may affect device reliability.

All values concerning the DC–DC controller, VDDH and VDDL blocks are with respect to ARTN. All others are with respect to VPORTN_{1,2} (unless otherwise noted).

Table 3. Operating Conditions

| Symbol | Parameter | Min. | Typ. | Max. | Units | Conditions |
|----------------------------|---|-------|------|-------|-------|--|
| INPUT SUPPLY | | | | | | |
| VPORT | Input supply voltage | 0 | | 57 | V | VPORT = VPORTP – VPORTN _{1,2} |
| SIGNATURE DETECTION | | | | | | |
| Vsignature | Input supply voltage signature detection range | 1.4 | | 9.5 | V | |
| Rsignature | Signature resistance (Note 4) | 23.75 | | 26.25 | kΩ | |
| Offset_current | I_VportP + I_Rtn | – | 1.8 | 5 | μA | VPORTP = RTN = 1.4 V |
| Sleep_current | I_VportP + I_Rtn | – | 15 | 25 | μA | VPORTP = RTN = 9.5 V |
| CLASSIFICATION | | | | | | |
| Vcl | Input supply voltage classification range | 13 | | 20.5 | V | |
| Iclass0 | Class 0: Rclass 10 kΩ (Note 5) | 0 | – | 4 | mA | Iclass0 = I_VportP + I_Rdet |
| Iclass1 | Class 1: Rclass 130 Ω (Note 5) | 9 | – | 12 | mA | Iclass1 = I_VportP + I_Rdet |
| Iclass2 | Class 2: Rclass 69.8 Ω (Note 5) | 17 | – | 20 | mA | Iclass2 = I_VportP + I_Rdet |
| Iclass3 | Class 3: Rclass 44.2 Ω (Note 5) | 26 | – | 30 | mA | Iclass3 = I_VportP + I_Rdet |
| Iclass4 | Class 4: Rclass 30.9 Ω (Note 5) | 36 | – | 44 | mA | Iclass4 = I_VportP + I_Rdet |
| IDC _{class} | Internal current consumption during classification (Note 6) | – | 600 | – | μA | For information only |
| UVLO | | | | | | |
| Vuvlo_on | Default turn on voltage (VportP rising) | | 38 | 40 | V | UVLO pin tied to VPORTN _{1,2} |
| Vuvlo_off | Default turn off voltage (VportP falling) | 29.5 | 32 | – | V | UVLO pin tied to VPORTN _{1,2} |
| Vhyst_int | UVLO internal hysteresis | – | 6 | – | V | UVLO pin tied to VPORTN _{1,2} |
| Vuvlo_pr | UVLO external programming range | 25 | – | 50 | V | UVLO pin connected to the resistor divider (R1 & R2). For information only |
| Vhyst_ext | UVLO external hysteresis | – | 15 | – | % | UVLO pin connected to the resistor divider (R1 & R2) |
| Uvlo_Filter | UVLO on/off filter time | – | 90 | – | μS | |

4. Test done according to the IEEE802.3af 2 Point Measurement. The minimum probe voltages measured at the PoE–PD are 1.4 V and 2.4 V, and the maximum probe voltages are 8.5 V and 9.5 V.
5. Measured with an external Rdet of 25.5 kΩ between VPORTP and VPORTN_{1,2}, and for 13 V < VPORT < 20.5 V (with VPORT = VPORTP – VPORTN_{1,2}).
6. This typical current excludes the current in the Rclass and Rdet external resistors.

NCP1080

Table 3. Operating Conditions

| Symbol | Parameter | Min. | Typ. | Max. | Units | Conditions |
|--|---|------------|-----------------------------|-------------|-------|--|
| PASS-SWITCH AND CURRENT LIMITS | | | | | | |
| R _{on} | Pass-switch R _{ds-on} | – | 0.6 | 1.2 | Ω | Max R _{on} specified at T _j = 130°C |
| I _{Rinrush1} | Rinrush = 150 kΩ (Note 7) | 95 | 125 | 155 | mA | Measured at RTN–VPORTN _{1,2} = 3 V |
| I _{Rinrush2} | Rinrush = 57.6 kΩ (Note 7) | 260 | 310 | 360 | mA | Measured at RTN–VPORTN _{1,2} = 3 V |
| I _{Rilim1} | Rilim1 = 84.5 kΩ (Note 7) | 450 | 510 | 570 | mA | Current limit threshold |
| INRUSH AND ILIM1 CURRENT LIMIT TRANSITION | | | | | | |
| V _{ds_pgood} | V _{DS} required for power good status | 0.8 | 1 | 1.2 | V | RTN–VPORTN _{1,2} falling; voltage with respect to VPORTN _{1,2} |
| V _{ds_pgood_hyst} | V _{DS} hysteresis required for power good status | – | 8.2 | – | V | Voltage with respect to VPORTN _{1,2} |
| VDDH REGULATOR | | | | | | |
| VDDH _{reg} | Regulator output voltage (Notes 8 and 9) I _{vddh_load} + I _{vddl_load} < 10 mA with 0 < I _{vddl_load} < 2.25 mA | 8.4 | 9 | 9.6 | V | |
| VDDH _{Off} | Regulator turn-off voltage | – | VDDH _{reg} + 0.5 V | – | V | For information only |
| VDDH _{lim} | VDDH regulator current limit (Notes 8 and 9) | 13 | – | 26 | mA | |
| VDDH _{Por_R} | VDDH POR level (rising) | 7.3 | – | 8.3 | V | |
| VDDH _{Por_F} | VDDH POR level (falling) | 6 | – | 7 | V | |
| VDDH _{ovlo} | VDDH over-voltage level (rising) | 16 | – | 18.5 | V | |
| VDDL REGULATOR | | | | | | |
| VDDL _{reg} | Regulator output voltage (Notes 8 and 9) 0 < I _{vddl_load} < 2.25 mA with I _{vddh_load} + I _{vddl_load} < 10 mA | 3.05 | 3.3 | 3.55 | V | |
| VDDL _{Por_R} | VDDL POR level (rising) | VDDL – 0.2 | – | VDDL – 0.02 | V | |
| VDDL _{Por_F} | VDDL POR level (falling) | 2.5 | – | 2.9 | V | |
| GATE DRIVER | | | | | | |
| Gate _{Tr} | GATE rise time (10–90%) | – | – | 50 | ns | C _{load} = 2 nF, VDDH _{reg} = 9 V |
| Gate _{Tf} | GATE fall time (90–10%) | – | – | 50 | ns | C _{load} = 2 nF, VDDH _{reg} = 9 V |
| PWM COMPARATOR | | | | | | |
| VCOMP | COMP control voltage range | 1.3 | – | 3 | V | For information only |

7. The current value corresponds to the PoE–PD input current (the current flowing in the external R_{det} and the quiescent current of the device are included).

8. Power dissipation must be considered. Load on VDDH and VDDL must be limited especially if VDDH is not powered by an auxiliary winding.

9. I_{vddl_load} = current flowing out of the VDDL pin.

I_{vddh_load} = current flowing out of the VDDH pin + current delivered to the Gate Driver (function of the frequency, VDDH voltage & MOSFET gate capacitance).

NCP1080

Table 3. Operating Conditions

| Symbol | Parameter | Min. | Typ. | Max. | Units | Conditions |
|---------------------------------|---|------|------|------------|-------------------|--|
| ERROR AMPLIFIER | | | | | | |
| Vbg_fb | Reference voltage | 1.15 | 1.2 | 1.25 | V | Voltage with respect to ARTN |
| Av_ol | DC open loop gain | – | 80 | – | dB | For information only |
| GBW | Error amplifier GBW | 1 | – | – | MHz | For information only |
| SOFT-START | | | | | | |
| Vss | Soft-start voltage range | – | 1.15 | – | V | |
| Vss_r | Soft-start low threshold (rising edge) | 0.35 | 0.45 | 0.55 | V | |
| Iss | Soft-start source current | 3 | 5 | 7 | μA | |
| CURRENT LIMIT COMPARATOR | | | | | | |
| CSth | CS threshold voltage | 324 | 360 | 396 | mV | |
| Tblank | Blanking time | – | 100 | – | ns | For information only |
| OSCILLATOR | | | | | | |
| DutyC | Maximum duty cycle | – | 80% | – | | Fixed internally |
| Frang | Oscillator frequency range | 100 | – | 500 | kHz | |
| F_acc | Oscillator frequency accuracy | | ±25 | | % | |
| CURRENT CONSUMPTION | | | | | | |
| IvportP ₁ | VPORTP internal current consumption (Note 10) | – | 2.5 | 3.5 | mA | DC-DC controller off |
| IvportP ₂ | VPORTP internal current consumption (Note 11) | – | 4.7 | 6.5 | mA | DC-DC controller on |
| THERMAL SHUTDOWN | | | | | | |
| TSD | Thermal shutdown threshold | 150 | – | – | °C T _j | T _j = junction temperature |
| Thyst | Thermal hysteresis | – | 15 | – | °C T _j | T _j = junction temperature |
| THERMAL RATINGS | | | | | | |
| Ta | Ambient temperature | –40 | – | 85 | °C | |
| Tj | Junction temperature | – | – | 125 150 | °C °C | Parametric values guaranteed Max 1000 hours |

10. Conditions

- a. No current through the pass-switch
- b. DC-DC controller inactive (SS shorted to RTN)
- c. No external load on VDDH and VDDL
- d. VPORTP = 57 V

11. Conditions

- a. No current through the pass-switch
- b. Oscillator frequency = 100 kHz
- c. No external load on VDDH and VDDL
- d. Aux winding not used
- e. 2 nF on GATE, DC-DC controller enabled
- f. VPORTP = 57 V

Description of Operation

Powered Device Interface

The PD interface portion of the NCP1080 supports the IEEE802.3af defined operating modes: detection signature, current source classification, inrush and operating current limits. In order to give more flexibility to the user and also to keep control of the power dissipation in the NCP1080, both current limits are configurable. The device enters operation once its programmable Vuvlo_on threshold is reached, and operation ceases when the supplied voltage falls below the Vuvlo_off threshold. Sufficient hysteresis and Uvlo filter time are provided to avoid false power on/off cycles due to transient voltage drops on the cable.

Detection

During the detection phase, the incremental equivalent resistance seen by the PSE through the cable must be in the IEEE802.3af standard specification range (23.75 kΩ to 26.25 kΩ) for a PSE voltage from 2.7 V to 10.1 V. In order to compensate for the non-linear effect of the diode bridge and satisfy the specification at low PSE voltage, the NCP1080 presents a suitable impedance in parallel with the 25.5 kΩ Rdet external resistor. For some types of diodes (especially Schottky diodes), it may be necessary to adjust this external resistor.

When the Detection_Off level is detected (typically 11.5 V) on VPORTP, the NCP1080 turns on its internal 3.3 V regulator and biasing circuitry in anticipation of the classification phase as the next step.

Classification

Once the PSE device has detected the PD device, the classification process begins. In classification, the PD regulates a constant current source that is set by the external resistor RCLASS value on the CLASS pin. Figure 6 shows the schematic overview of the classification block. The current source is defined as:

$$I_{class} = \frac{V_{bg}}{R_{class}}, \text{ (where } V_{bg} \text{ is } 1.2 \text{ V)}$$

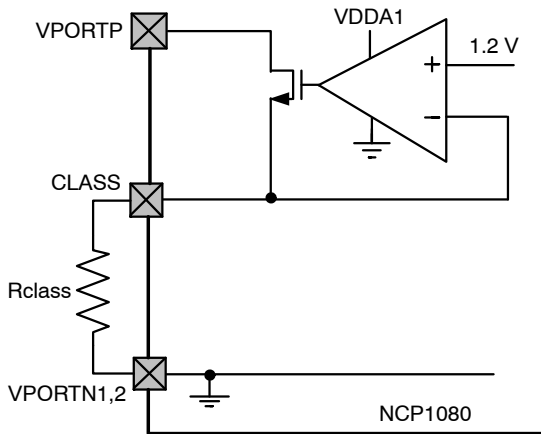

Figure 6. Classification Block Diagram

Power Mode

When the classification hand-shake is completed, the PSE and PD devices move into the operating mode.

Under Voltage Lock Out (UVLO)

The NCP1080 incorporates an under voltage lock out (UVLO) circuit which monitors the input voltage and determines when to apply power to the DC-DC controller.

To use the default settings for UVLO (see Table 3), the pin UVLO must be connected to VPORTN1,2. In this case the signature resistor has to be placed directly between VPORTP and VPORTN1,2, as shown in Figure 7.

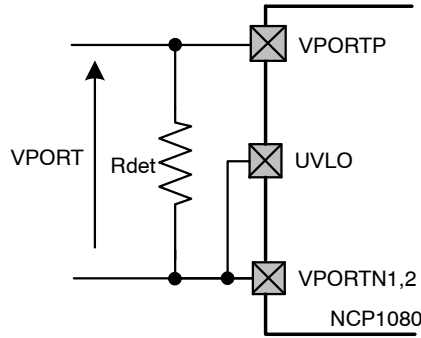

Figure 7. Default UVLO Settings

To define the UVLO threshold externally, the UVLO pin must be connected to the center of an external resistor divider between VPORTP and VPORTN1,2 as shown in Figure 8. The series resistance value of the external resistors must add to 25.5 kΩ and replaces the internal signature resistor.

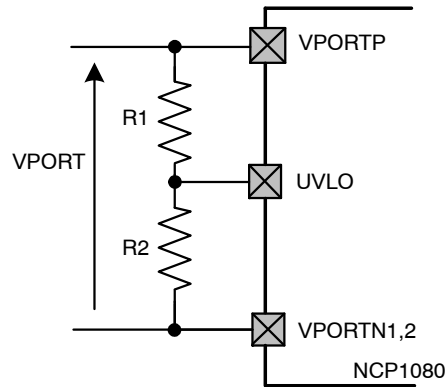

Figure 8. External UVLO Configuration

For a Vuvlo_on desired turn-on voltage threshold, R1 and R2 can be calculated using the following equations:

$$R1 + R2 = R_{det}$$

$$R2 = \frac{1.2}{V_{ulvo_on}} \times R_{det}$$

NCP1080

When using the external resistor divider, the NCP1080 has an external reference voltage hysteresis of 15 percent typical.

Inrush and Operational Current Limitations

The inrush current limit and the operational current limit are programmed individually by an external Rinrush and Rilim1 resistors respectively connected between INRUSH and VPORTN_{1,2}, and between ILIM1 and VPORTN_{1,2} as shown in Figure 9.

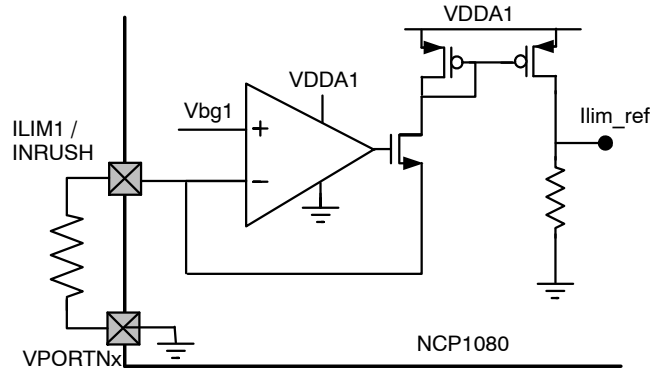

Figure 9. Current Limitation Configuration (Inrush & Ilim1 Pins)

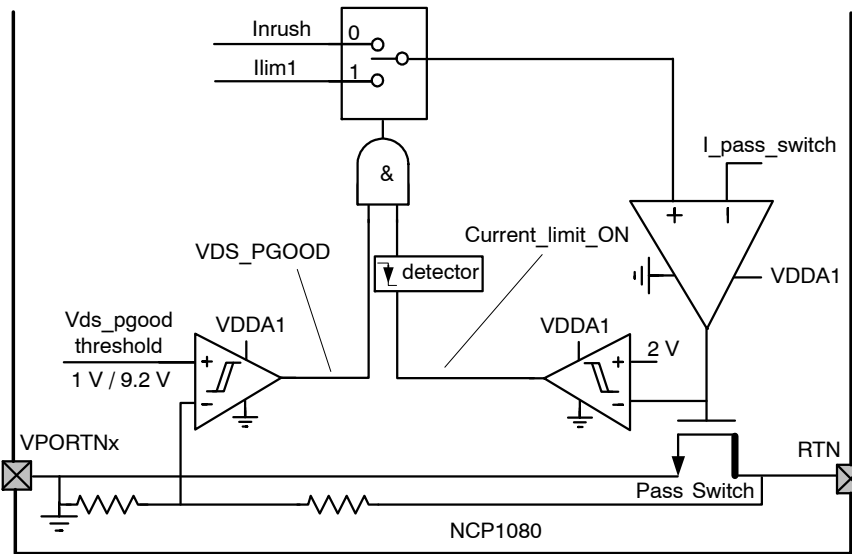

Figure 10. Inrush and Ilim1 Selection Mechanism

When VPORT reaches the UVLO_{on} level, the Cpd capacitor is charged with the INRUSH current (in order to limit the internal power dissipation of the pass-switch). Once the Cpd capacitor is fully charged, the current limit switches from the inrush current to the current limit level (ilim1) as shown in Figure 10. This transition occurs when both following conditions are satisfied:

1. The VDS of the pass-switch is below the Vds_pgood low level (1 V typical).
2. The pass-switch is no longer in current limit mode, meaning the gate of the pass-switch is “high” (above 2 V typical).

The operational current limit will stay selected as long as Vds_pgood is true (meaning that RTN-VPORTN_{1,2} is below the high level of Vds_pgood). This mechanism allows a current level transition without any current spike in the pass-switch because the operational current limit (ilim1) is

enabled once the pass-switch is not limiting the current anymore, meaning that the Cpd capacitor is fully charged.

Thermal Shutdown

The NCP1080 includes thermal protection which shuts down the device in case of high power dissipation. Once the thermal shutdown (TSD) threshold is exceeded, following blocks are turned off:

- DC-DC controller
- Pass-switch
- VDDH and VDDL regulators
- CLASS regulator

When the TSD error disappears and if the input line voltage is still above the UVLO level, the NCP1080 automatically restarts with the current limit set in the inrush state, the DC-DC controller is disabled and the C_{ss}

NCP1080

(soft-start capacitor) discharged. The DC-DC controller becomes operational as soon as $RTN-V_{PORTN_{1,2}}$ is below the V_{ds_pgood} threshold.

DC-DC Converter Controller

The NCP1080 implements a current mode DC-DC converter controller which is illustrated in Figure 11.

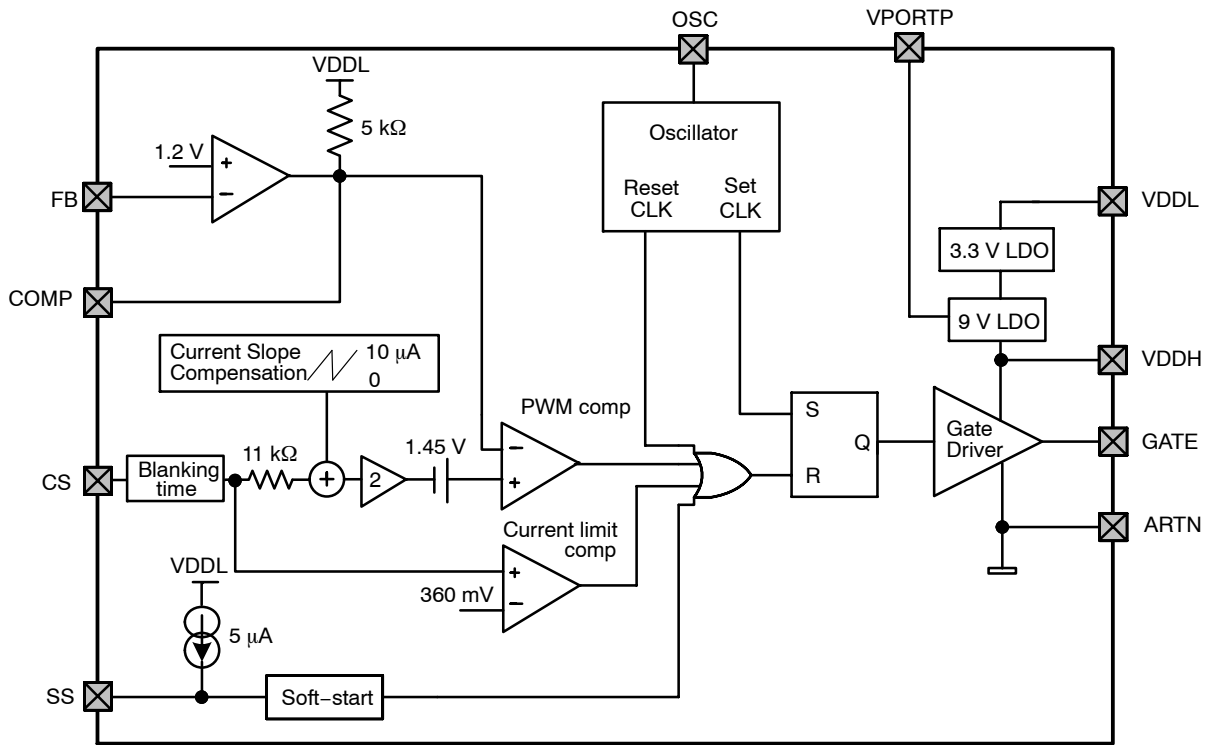

Figure 11. DC-DC Controller Block Diagram

Internal VDDH and VDDL Regulators and Gate Driver

An internal linear regulator steps down the V_{PORTP} voltage to a 9 V output on the V_{DDH} pin. V_{DDH} supplies the internal gate driver circuit which drives the $GATE$ pin and the gate of the external power MOSFET. The NCP1080 gate driver supports an external MOSFET with high V_{th} and high input gate capacitance. A second LDO regulator steps down the V_{DDH} voltage to a 3.3 V output on V_{DDL} . V_{DDL} powers the analog circuitry of the DC-DC controller.

In order to prevent uncontrolled operations, both regulators include power-on-reset (POR) detectors which prevent the DC-DC controller from operating when either V_{DDH} or V_{DDL} is too low. In addition, an over-voltage lockout (OVLO) on the V_{DDH} supply disables the gate driver in case of an open-loop converter with a configuration using the bias winding of the transformer (see Figure 4).

Both V_{DDH} and V_{DDL} regulators turn on as soon as V_{PORT} reaches the V_{uvlo_on} threshold.

Error Amplifier

In non-isolated converter topologies, the high gain internal error amplifier of the NCP1080 and the internal 1.2 V reference voltage regulate the DC-DC output voltage. In this configuration, the feedback loop compensation network should be inserted between the FB and $COMP$ pins as shown in Figures 3, 4 and 5.

In isolated topologies the error amplifier is not used because it is already implemented externally with the shunt regulator on the secondary side of the DC-DC controller (see Figure 2). Therefore the FB pin must be strapped to $ARTN$ and the output transistor of the opto-coupler has to be connected on the $COMP$ pin where an internal 5 k Ω pull-up resistor is tied to the V_{DDL} supply (see Figure 11).

Soft-Start

The soft-start function provided by the NCP1080 allows the output voltage to ramp up in a controlled fashion, eliminating output voltage overshoot. This function is programmed by connecting a capacitor C_{ss} between the SS and $ARTN$ pins.

While the DC-DC controller is in POR, the capacitor C_{ss} is fully discharged. After coming out of POR, an internal current source of 5 μA typically starts charging the capacitor C_{ss} to initiate soft-start. When the voltage on SS pin has reached 0.45 V (typical), the gate driver is enabled and DC-DC operation starts with a duty cycle limit which increases with the SS pin voltage. The soft-start function is finished when the SS pin voltage goes above 1.6 V for which the duty cycle limit reaches its maximum value of 80 percent.

Soft-start can be programmed by using the following equation:

$$t_{ss}(ms) = 0.23 \times C_{ss}(nf)$$

NCP1080

Current Limit Comparator

The NCP1080 current limit block behind the CS pin senses the current flowing in the external MOSFET for current mode control and cycle-by-cycle current limit. This is performed by the current limit comparator which, on the CS pin, senses the voltage across the external Rcs resistor located between the source of the MOSFET and the ARTN pin.

The NCP1080 also provides a blanking time function on CS pin which ensures that the current limit and PWM comparators are not prematurely triggered by the current spike that occurs when the switching MOSFET turns on.

Slope Compensation Circuitry

To overcome sub-harmonic oscillations and instability problems that exist with converters running in continuous

conduction mode (CCM) and when the duty cycle is close or above 50 percent, the NCP1080 integrates a current slope compensation circuit. The amplitude of the added slope compensation is typically 110 mV over one cycle.

As an example, for an operating switching frequency of 250 kHz, the internal slope provided by the NCP1080 is 27.5 mV/μA typically.

DC-DC Controller Oscillator

The frequency is configured with the R_{osc} resistor inserted between OSC and ARTN, and is defined by the following equation:

$$R_{OSC}(k\Omega) = \frac{38600}{F_{OSC}(kHz)}$$

The duty cycle limit is fixed internally at 80 percent.

NCP1080

PACKAGE DIMENSIONS

TSSOP-20 EP
CASE 948AB-01
ISSUE O

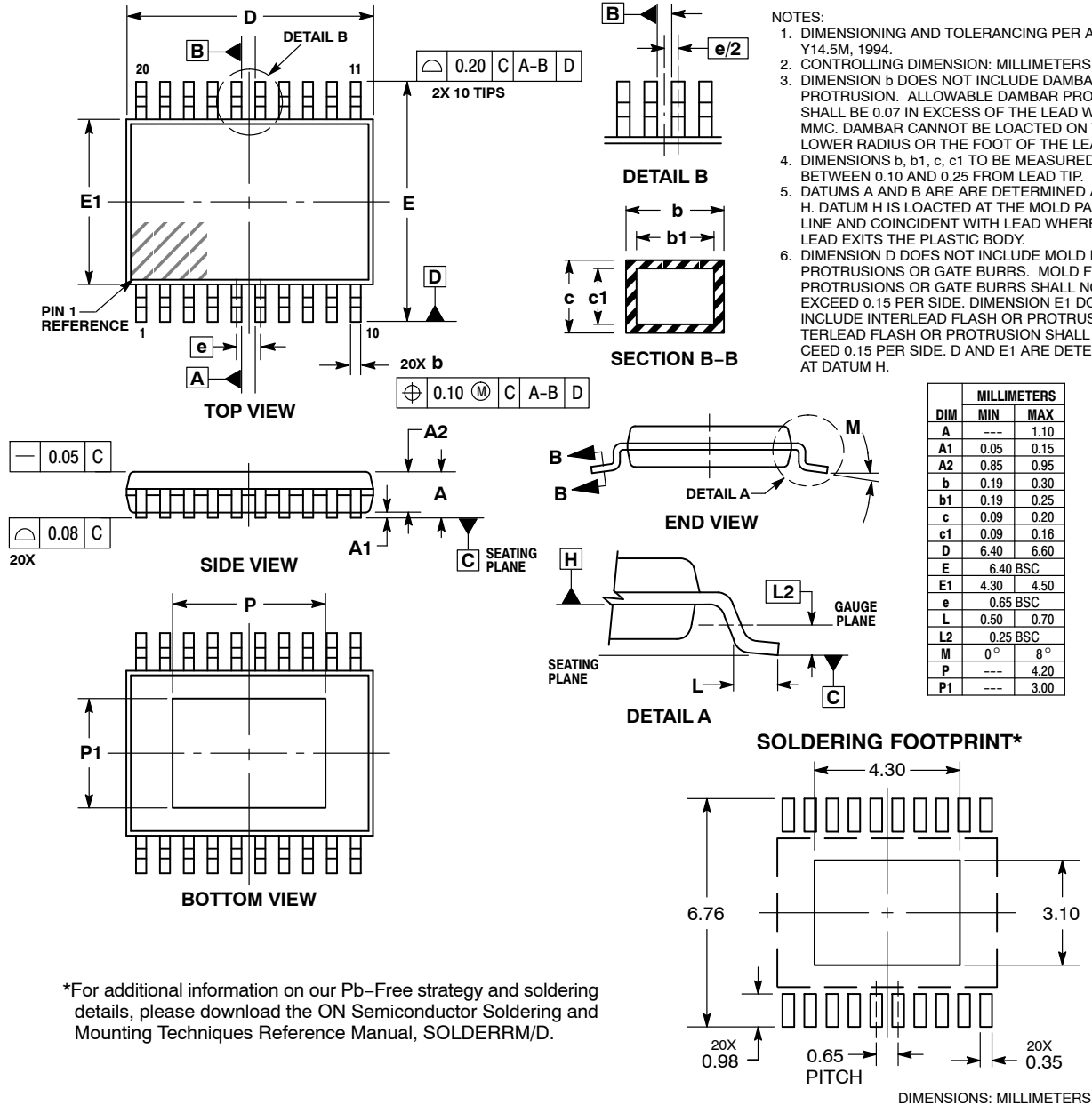

*For additional information on our Pb-Free strategy and soldering details, please download the ON Semiconductor Soldering and Mounting Techniques Reference Manual, SOLDERRM/D.

ON Semiconductor and are registered trademarks of Semiconductor Components Industries, LLC (SCILLC). SCILLC reserves the right to make changes without further notice to any products herein. SCILLC makes no warranty, representation or guarantee regarding the suitability of its products for any particular purpose, nor does SCILLC assume any liability arising out of the application or use of any product or circuit, and specifically disclaims any and all liability, including without limitation special, consequential or incidental damages. "Typical" parameters which may be provided in SCILLC data sheets and/or specifications can and do vary in different applications and actual performance may vary over time. All operating parameters, including "Typicals" must be validated for each customer application by customer's technical experts. SCILLC does not convey any license under its patent rights nor the rights of others. SCILLC products are not designed, intended, or authorized for use as components in systems intended for surgical implant into the body, or other applications intended to support or sustain life, or for any other application in which the failure of the SCILLC product could create a situation where personal injury or death may occur. Should Buyer purchase or use SCILLC products for any such unintended or unauthorized application, Buyer shall indemnify and hold SCILLC and its officers, employees, subsidiaries, affiliates, and distributors harmless against all claims, costs, damages, and expenses, and reasonable attorney fees arising out of, directly or indirectly, any claim of personal injury or death associated with such unintended or unauthorized use, even if such claim alleges that SCILLC was negligent regarding the design or manufacture of the part. SCILLC is an Equal Opportunity/Affirmative Action Employer. This literature is subject to all applicable copyright laws and is not for resale in any manner.

PUBLICATION ORDERING INFORMATION

LITERATURE FULFILLMENT:
Literature Distribution Center for ON Semiconductor
P.O. Box 5163, Denver, Colorado 80217 USA
Phone: 303-675-2175 or 800-344-3860 Toll Free USA/Canada
Fax: 303-675-2176 or 800-344-3867 Toll Free USA/Canada
Email: orderlit@onsemi.com

N. American Technical Support: 800-282-9855 Toll Free
USA/Canada
Europe, Middle East and Africa Technical Support:
Phone: 421 33 790 2910
Japan Customer Focus Center
Phone: 81-3-5817-1050

ON Semiconductor Website: www.onsemi.com
Order Literature: <http://www.onsemi.com/orderlit>
For additional information, please contact your local Sales Representative

Компания «Life Electronics» занимается поставками электронных компонентов импортного и отечественного производства от производителей и со складов крупных дистрибьюторов Европы, Америки и Азии.

С конца 2013 года компания активно расширяет линейку поставок компонентов по направлению коаксиальный кабель, кварцевые генераторы и конденсаторы (керамические, пленочные, электролитические), за счёт заключения дистрибьюторских договоров

Мы предлагаем:

- Конкурентоспособные цены и скидки постоянным клиентам.
- Специальные условия для постоянных клиентов.
- Подбор аналогов.
- Поставку компонентов в любых объемах, удовлетворяющих вашим потребностям.
- Приемлемые сроки поставки, возможна ускоренная поставка.
- Доставку товара в любую точку России и стран СНГ.
- Комплексную поставку.
- Работу по проектам и поставку образцов.
- Формирование склада под заказчика.
- Сертификаты соответствия на поставляемую продукцию (по желанию клиента).
- Тестирование поставляемой продукции.
- Поставку компонентов, требующих военную и космическую приемку.
- Входной контроль качества.
- Наличие сертификата ISO.

В составе нашей компании организован Конструкторский отдел, призванный помогать разработчикам, и инженерам.

Конструкторский отдел помогает осуществить:

- Регистрацию проекта у производителя компонентов.
- Техническую поддержку проекта.
- Защиту от снятия компонента с производства.
- Оценку стоимости проекта по компонентам.
- Изготовление тестовой платы монтаж и пусконаладочные работы.



Тел: +7 (812) 336 43 04 (многоканальный)

Email: org@lifeelectronics.ru