

EL7155

High Performance Pin Driver

FN7279  
Rev 3.00  
October 24, 2014

The EL7155 high performance pin driver with 3-state is suited to many ATE and level-shifting applications. The 3.5A peak drive capability makes this part an excellent choice when driving high capacitance loads.

Output pins  $OUT_H$  and  $OUT_L$  are connected to input pins  $V_H$  and  $V_L$  respectively, depending on the status of the IN pin. One of the output pins is always in tri-state, except when the OE pin is low, in which case both outputs are in tri-state mode. The isolation of the output FETs from the power supplies enables  $V_H$  and  $V_L$  to be set independently, enabling level-shifting to be implemented.

This pin driver has improved performance over existing pin drivers. It is specifically designed to operate at voltages down to 0V across the switch elements while maintaining good speed and ON-resistance characteristics.

Available in an 8 Ld SOIC package, the EL7155 is specified for operation over the full  $-40^{\circ}C$  to  $+85^{\circ}C$  temperature range.

**Features**

- Clocking speeds up to 40MHz
- 15ns tr/tf at 2000pF  $C_{LOAD}$
- 0.5ns rise and fall times mismatch
- 0.5ns  $t_{ON}-t_{OFF}$  prop delay mismatch
- 3.5pF typical input capacitance
- 3.5A peak drive
- Low ON-resistance of  $3.5\Omega$
- High capacitive drive capability
- Operates from 4.5V up to 16.5V
- Pb-free (RoHS compliant)

**Applications**

- ATE/burn-in testers
- Level shifting
- IGBT drivers
- CCD drivers



FIGURE 1. BLOCK DIAGRAM

## Pin Configuration

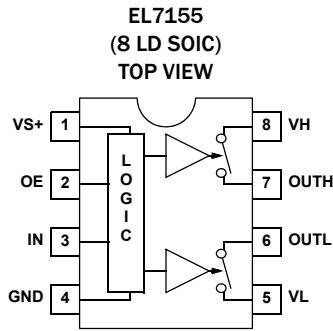

## Pin Descriptions

PIN #	PIN NAME	FUNCTION	EQUIVALENT CIRCUIT
1	VS+	Positive Supply Voltage	
2	OE	Output Enable	<p>Circuit 1</p>
3	IN	Input	Reference Circuit 1
4	GND	Ground	
5	VL	Negative Supply and Lower Output Voltage	
6	OUTL	Lower Switch Output	<p>Circuit 2</p>
7	OUTH	Upper Switch Output	<p>Circuit 3</p>
8	VH	Upper Output Voltage	

## Ordering Information

PART NUMBER (Notes 1, 2)	PART MARKING	PACKAGE (Pb-Free)	PKG. DWG. #
EL7155CSZ	7155CSZ	8 Ld SOIC	M8.15E
EL7155CSZ-T7 (Note 3)	7155CSZ	8 Ld SOIC	M8.15E
EL7155CSZ-T7A (Note 3)	7155CSZ	8 Ld SOIC	M8.15E
EL7155CSZ-T13 (Note 3)	7155CSZ	8 Ld SOIC	M8.15E

**NOTE:**

1. Intersil Pb-free plus anneal products employ special Pb-free material sets; molding compounds/die attach materials and 100% matte tin plate termination finish, which are RoHS compliant and compatible with both SnPb and Pb-free soldering operations. Intersil Pb-free products are MSL classified at Pb-free peak reflow temperatures that meet or exceed the Pb-free requirements of IPC/JEDEC J STD-020.
2. For Moisture Sensitivity Level (MSL), please see product information page for [EL7155](#). For more information on MSL, please see tech brief [TB363](#).
3. Please refer to [TB347](#) for details on reel specifications.

**Absolute Maximum Ratings** ( $T_A = +25^\circ\text{C}$ )

Supply Voltage ( $V_{S+}$ to $V_L$ )	+18V
$V_H$ - $V_L$ , $V_H$ to GND, $V_{S+}$ to $V_H$	.16.5V
Input Voltage	-0.3V below $V_L$ to +0.3V above $V_S$
Continuous Output Current	200mA
Storage Temperature Range	-65°C to +150°C

**Thermal Information**

Ambient Operating Temperature	-40°C to +85°C
Operating Junction Temperature	+125°C
Power Dissipation	see curves
Pb-Free Reflow Profile	see <a href="#">TB493</a>

CAUTION: Do not operate at or near the maximum ratings listed for extended periods of time. Exposure to such conditions may adversely impact product reliability and result in failures not covered by warranty.

**Electrical Specifications**  $V_{S+} = +15\text{V}$ ,  $V_H = +15\text{V}$ ,  $V_L = 0\text{V}$ ,  $T_A = +25^\circ\text{C}$ , all tests are at the specified temperature and are pulsed tests, therefore:  $T_J = T_C = T_A$ , unless otherwise specified.

SYMBOL	PARAMETER	TEST CONDITIONS	MIN (Note 4)	TYP (Note 5)	MAX (Note 4)	UNITS
<b>INPUT</b>						
$V_{IH}$	Logic '1' Input Voltage		2.4			V
$I_{IH}$	Logic '1' Input Current	$V_{IH} = V_{S+}$		0.1	10	$\mu\text{A}$
$V_{IL}$	Logic '0' Input Voltage				0.8	V
$I_{IL}$	Logic '0' Input Current	$V_{IL} = 0\text{V}$		0.1	10	$\mu\text{A}$
$C_{IN}$	Input Capacitance			3.5		pF
$R_{IN}$	Input Resistance			50		M $\Omega$
<b>OUTPUT</b>						
$R_{OVH}$	ON-Resistance $V_H$ to $OUT_H$	$I_{OUT} = -200\text{mA}$		2.7	4.5	$\Omega$
$R_{OVL}$	ON-Resistance $V_L$ to $OUT_L$	$I_{OUT} = +200\text{mA}$		3.5	5.5	$\Omega$
$I_{OUT}$	Output Leakage Current	$OE = 0\text{V}$ , $OUT_H = V_L$ , $OUT_L = V_{S+}$		0.1	10	$\mu\text{A}$
$I_{PK}$	Peak Output Current (linear resistive operation)	Source		3.5		A
		Sink		3.5		A
$I_{DC}$	Continuous Output Current	Source/Sink	200			mA
<b>POWER SUPPLY</b>						
$I_S$	Power Supply Current	Inputs = $V_{S+}$		1.3	3	mA
$I_{VH}$	Off Leakage at $V_H$	$V_H = 0\text{V}$		4	10	$\mu\text{A}$
<b>SWITCHING CHARACTERISTICS</b>						
$t_R$	Rise Time	$C_L = 2000\text{pF}$		14.5		ns
$t_F$	Fall Time	$C_L = 2000\text{pF}$		15		ns
$t_{RF\Delta}$	$t_R$ , $t_F$ Mismatch	$C_L = 2000\text{pF}$		0.5		ns
$t_{D-1}$	Turn-Off Delay Time	$C_L = 2000\text{pF}$		9.5		ns
$t_{D-2}$	Turn-On Delay Time	$C_L = 2000\text{pF}$		10		ns
$t_{D\Delta}$	$t_{D-1}$ - $t_{D-2}$ Mismatch	$C_L = 2000\text{pF}$		0.5		ns
$t_{D-3}$	3-state Delay Enable			10		ns
$t_{D-4}$	3-state Delay Disable			10		ns

**Electrical Specifications**  $V_S = +5V$ ,  $V_H = +5V$ ,  $V_L = -5V$ ,  $T_A = +25^\circ C$ , all tests are at the specified temperature and are pulsed tests, therefore:  $T_J = T_C = T_A$ , unless otherwise specified.

PARAMETER	DESCRIPTION	CONDITION	MIN (Note 4)	TYP (Note 5)	MAX (Note 4)	UNIT
<b>INPUT</b>						
$V_{IH}$	Logic '1' Input Voltage		2.0			V
$I_{IH}$	Logic '1' Input Current	$V_{IH} = V_S +$		0.1	10	$\mu A$
$V_{IL}$	Logic '0' Input Voltage				0.8	V
$I_{IL}$	Logic '0' Input Current	$V_{IL} = 0V$		0.1	10	$\mu A$
$C_{IN}$	Input Capacitance			3.5		pF
$R_{IN}$	Input Resistance			50		M $\Omega$
<b>OUTPUT</b>						
$R_{OVH}$	ON-Resistance $V_H$ to $OUT_H$	$I_{OUT} = -200mA$		3.4	5	$\Omega$
$R_{OVL}$	ON-Resistance $V_L$ to $OUT_L$	$I_{OUT} = +200mA$		4	6	$\Omega$
$I_{OUT}$	Output Leakage Current	$OE = 0V$ , $OUT_H = V_L$ , $OUT_L = V_S +$		0.1	10	$\mu A$
$I_{PK}$	Peak Output Current (linear resistive operation)	Source		3.5		A
		Sink		3.5		A
$I_{DC}$	Continuous Output Current	Source/Sink	200			mA
<b>POWER SUPPLY</b>						
$I_S$	Power Supply Current	Inputs = $V_S +$		1	2.5	mA
$I_{VH}$	Off Leakage at $V_H$	$V_H = 0V$		4	10	$\mu A$
<b>SWITCHING CHARACTERISTICS</b>						
$t_R$	Rise Time	$C_L = 2000pF$		17		ns
$t_F$	Fall Time	$C_L = 2000pF$		17		ns
$t_{RF\Delta}$	$t_R$ , $t_F$ Mismatch	$C_L = 2000pF$		0		ns
$t_{D-1}$	Turn-Off Delay Time	$C_L = 2000pF$		11.5		ns
$t_{D-2}$	Turn-On Delay Time	$C_L = 2000pF$		12		ns
$t_{D\Delta}$	$t_{D-1} - t_{D-2}$ Mismatch	$C_L = 2000pF$		0.5		ns
$t_{D-3}$	3-state Delay Enable			11		ns
$t_{D-4}$	3-state Delay Disable			11		ns

**NOTES:**

- Compliance to datasheet limits is assured by one or more methods: production test, characterization and/or design.
- Typical values are for information purposes only.

# Typical Performance Curves

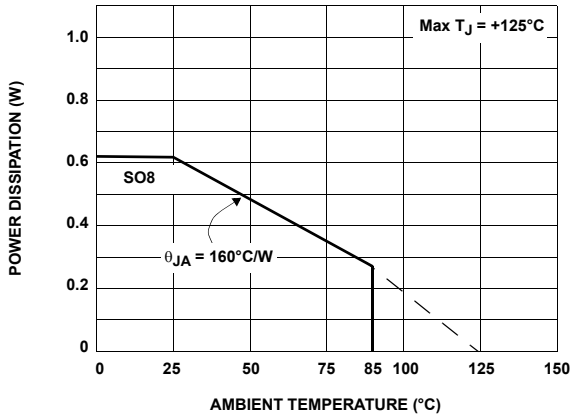

**FIGURE 2. PACKAGE POWER DISSIPATION vs AMBIENT TEMPERATURE JEDEC JESD51-3 LOW EFFECTIVE THERMAL CONDUCTIVITY TEST BOARD**

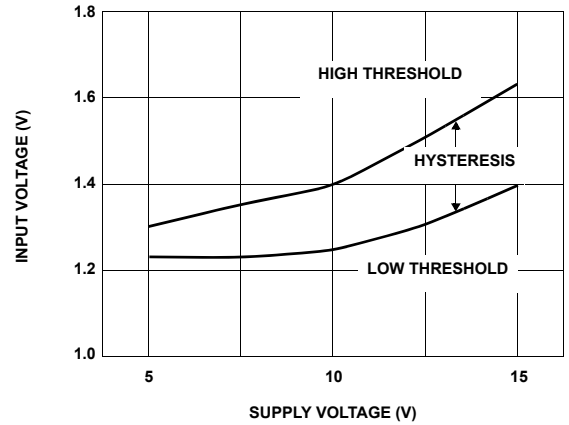

**FIGURE 3. INPUT THRESHOLD vs SUPPLY VOLTAGE, T = 25 °C**

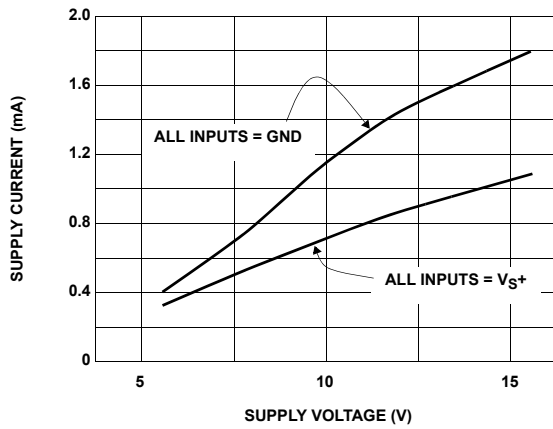

**FIGURE 4. QUIESCENT SUPPLY CURRENT vs SUPPLY VOLTAGE, T = +25 °C**

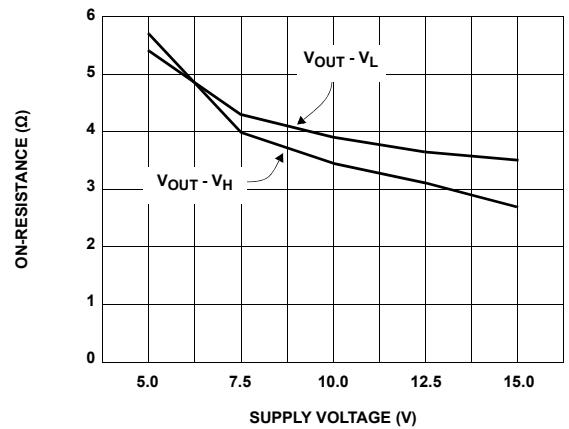

**FIGURE 5. ON-RESISTANCE vs SUPPLY VOLTAGE, I<sub>OUT</sub> = 200mA, T = +25 °C, V<sub>S+</sub> = V<sub>H</sub>, V<sub>L</sub> = 0V**

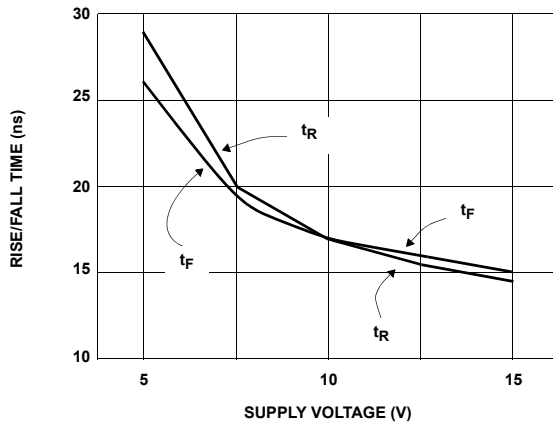

**FIGURE 6. RISE/FALL TIME vs SUPPLY VOLTAGE C<sub>L</sub> = 2000pF, T = +25 °C**

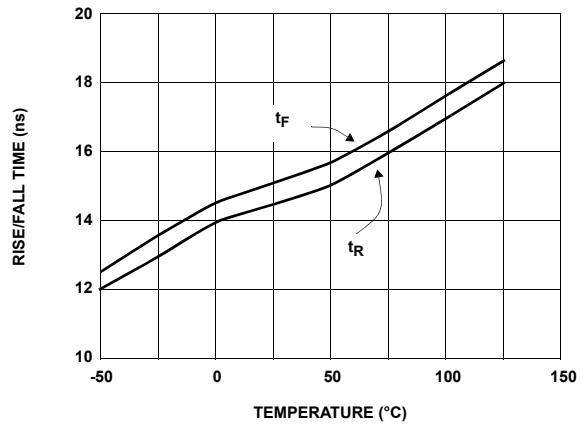

**FIGURE 7. RISE/FALL TIME vs TEMPERATURE C<sub>L</sub> = 2000PF, V<sub>S+</sub> = 15V**

# Typical Performance Curves (Continued)



**FIGURE 8. PROPAGATION DELAY vs SUPPLY VOLTAGE**  
 $C_L = 2000\text{pF}$ ,  $T = +25^\circ\text{C}$



**FIGURE 9. PROPAGATION DELAY vs TEMPERATURE**  
 $C_L = 2000\text{pF}$ ,  $V_{S+} = 15\text{V}$

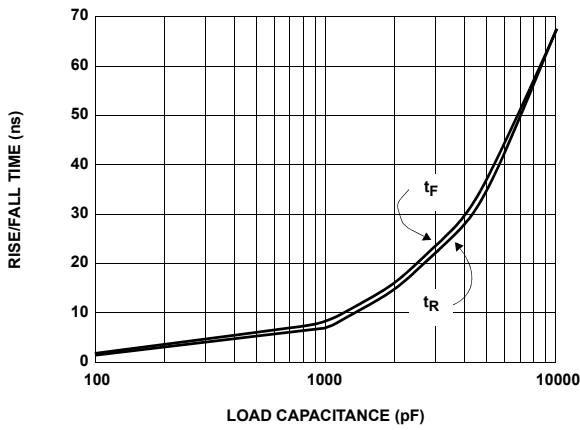

**FIGURE 10. RISE/FALL TIME vs LOAD CAPACITANCE**  
 $V_{S+} = +15\text{V}$ ,  $T = +25^\circ\text{C}$

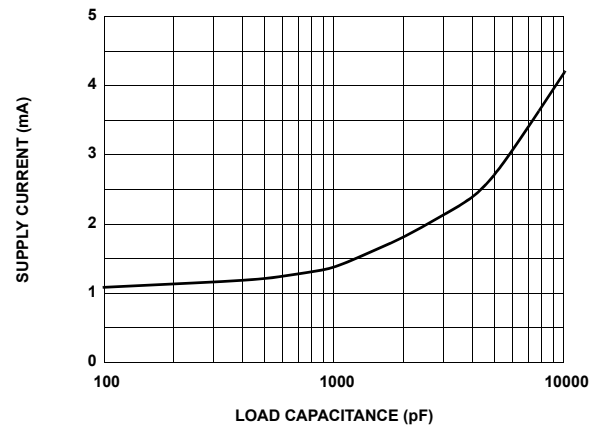

**FIGURE 11. SUPPLY CURRENT vs LOAD CAPACITANCE,**  
 $V_{S+} = V_H = 15\text{V}$ ,  $V_L = 0\text{V}$ ,  $T = +25^\circ\text{C}$ ,  $f = 20\text{kHz}$

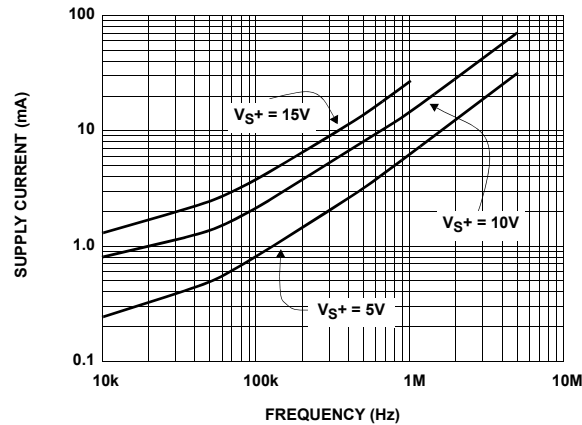

**FIGURE 12. SUPPLY CURRENT vs FREQUENCY,  $C_L = 1000\text{pF}$ ,  $T = +25^\circ\text{C}$**

TABLE 1. TRUTH TABLE

OE	IN	V <sub>H</sub> to OUT <sub>H</sub>	OUT <sub>L</sub> to V <sub>L</sub>
0	0	Open	Open
0	1	Open	Open
1	0	Closed	Open
1	1	Open	Closed

TABLE 2. OPERATING VOLTAGE RANGE

PIN	MIN (V)	MAX (V)
V <sub>L</sub> - GND	-5	0
V <sub>S+</sub> - V <sub>L</sub>	5	16.5
V <sub>H</sub> - V <sub>L</sub>	0	16.5
V <sub>S+</sub> - V <sub>H</sub>	0	16.5
V <sub>S+</sub> - GND	5	16.5
3-State Output	V <sub>L</sub>	V <sub>H</sub>

### Timing Diagrams

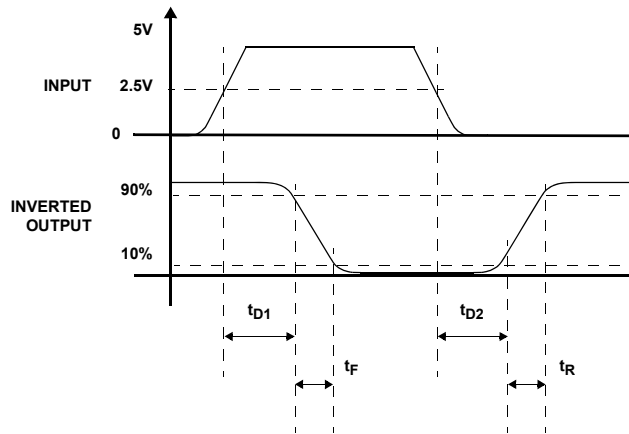

### Standard Test Configuration

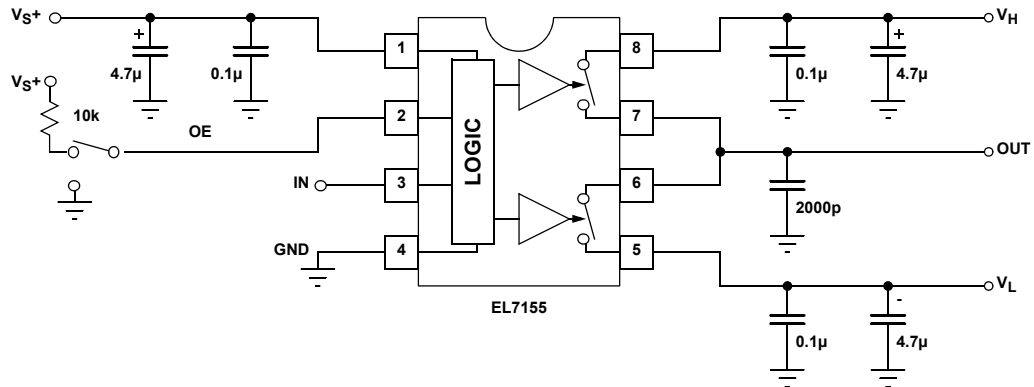

## Applications Information

### Product Description

The EL7155 is a high performance 40MHz pin driver. It contains two analog switches connecting  $V_H$  to  $OUT_H$  and  $V_L$  to  $OUT_L$ . Depending on the value of the IN pin, one of the two switches will be closed and the other switch open. An output enable (OE) is also supplied, which opens both switches simultaneously.

Due to the topology of the EL7155,  $V_L$  should always be connected to a voltage equal to or lower than GND.  $V_H$  can be connected to any voltage between  $V_L$  and the positive supply,  $V_{S+}$ .

The EL7155 is available in the 8 Ld SOIC package. Application dependent power dissipation should be calculated to ensure that the maximum junction temperature isn't violated.

### 3-state Operation

When the OE pin is low, the output is 3-state (floating.) The disabled output voltage is the parasitic capacitance's voltage. It can be any voltage between  $V_H$  and  $V_L$ , depending on the previous state. At 3-state, the output voltage can be driven to any voltage between  $V_H$  and  $V_L$ . The output voltage can't be driven higher than  $V_H$  or lower than  $V_L$  since the body diode at the output stage will turn on.

### Supply Voltage Range and Input Compatibility

The EL7155 is designed for operation on supplies from 5V to 15V (4.5V to 16.5V maximum). [Table 2 on page 7](#) shows the specifications for the relationship between the  $V_{S+}$ ,  $V_H$ ,  $V_L$ , and GND pins.

All input pins are compatible with both 3V and 5V CMOS signals. With a positive supply ( $V_{S+}$ ) of 5V, the EL7155 is also compatible with TTL inputs.

### Power Supply Bypassing

When using the EL7155, it is very important to use adequate power supply bypassing. The high switching currents developed by the EL7155 necessitate the use of a bypass capacitor between the  $V_{S+}$  and GND pins. It is recommended that a 2.2 $\mu$ F tantalum capacitor be used in parallel with a 0.1 $\mu$ F low-inductance ceramic MLC capacitor. These should be placed as close to the supply pins as possible. It is also recommended that the  $V_H$  and  $V_L$  pins have some level of bypassing, especially if the EL7155 is driving highly capacitive loads.

### Power Dissipation Calculation

When switching at high speeds, or driving heavy loads, the EL7155 drive capability is limited by the rise in die temperature brought about by internal power dissipation. For reliable operation die temperature must be kept below  $T_{JMAX}$  (+125°C). It is necessary to calculate the power dissipation for a given application prior to selecting the package type.

Power dissipation may be calculated:

$$PD = (V_S \times I_S) + (C_{INT} \times V_S^2 \times f) + (C_L \times V_{OUT}^2 \times f) \quad (EQ. 1)$$

where:

$V_S$  is the total power supply to the EL7155 (from  $V_{S+}$  to GND)

$V_{OUT}$  is the swing on the output ( $V_H - V_L$ )

$C_L$  is the load capacitance

$C_{INT}$  is the internal load capacitance (100pF max)

$I_S$  is the quiescent supply current (3mA max)

f is frequency

Having obtained the application's power dissipation, a maximum package thermal coefficient may be determined, to maintain the internal die temperature below  $T_{JMAX}$ :

$$\theta_{JA} = \frac{(T_{JMAX} - T_{MAX})}{PD} \quad (EQ. 2)$$

where:

$T_{JMAX}$  is the maximum junction temperature (+125°C)

$T_{MAX}$  is the maximum operating temperature

PD is the power dissipation calculated above

$\theta_{JA}$  thermal resistance on junction to ambient

$\theta_{JA}$  is 160°C/W for the SO8 package when using a standard JEDEC JESD51-3 single-layer test board. If  $T_{JMAX}$  is greater than +125°C when calculated using the [Equation 2](#), then one of the following actions must be taken:

1. Reduce  $\theta_{JA}$  the system by designing more heatsinking into the PCB (as compared to the standard JEDEC JESD51-3).
2. Derate the application either by reducing the switching frequency, the capacitive load, or the maximum operating (ambient) temperature ( $T_{MAX}$ ).



## Revision History

The revision history provided is for informational purposes only and is believed to be accurate, but not warranted. Please go to the web to make sure that you have the latest revision.

DATE	REVISION	CHANGE
October 24, 2014	FN7279.3	Updated datasheet to new Intersil template. Updated the Ordering Information table on page 2 by removing the obsolete products and adding the -T7A part. Added revision history and about Intersil.

## About Intersil

Intersil Corporation is a leading provider of innovative power management and precision analog solutions. The company's products address some of the largest markets within the industrial and infrastructure, mobile computing and high-end consumer markets.

For the most updated datasheet, application notes, related documentation and related parts, please see the respective product information page found at [www.intersil.com](http://www.intersil.com).

You may report errors or suggestions for improving this datasheet by visiting [www.intersil.com/ask](http://www.intersil.com/ask).

Reliability reports are also available from our website at [www.intersil.com/support](http://www.intersil.com/support)

© Copyright Intersil Americas LLC 2003-2014. All Rights Reserved.  
All trademarks and registered trademarks are the property of their respective owners.

For additional products, see [www.intersil.com/en/products.html](http://www.intersil.com/en/products.html)

Intersil products are manufactured, assembled and tested utilizing ISO9001 quality systems as noted in the quality certifications found at [www.intersil.com/en/support/qualandreliability.html](http://www.intersil.com/en/support/qualandreliability.html)

*Intersil products are sold by description only. Intersil may modify the circuit design and/or specifications of products at any time without notice, provided that such modification does not, in Intersil's sole judgment, affect the form, fit or function of the product. Accordingly, the reader is cautioned to verify that datasheets are current before placing orders. Information furnished by Intersil is believed to be accurate and reliable. However, no responsibility is assumed by Intersil or its subsidiaries for its use; nor for any infringements of patents or other rights of third parties which may result from its use. No license is granted by implication or otherwise under any patent or patent rights of Intersil or its subsidiaries.*

For information regarding Intersil Corporation and its products, see [www.intersil.com](http://www.intersil.com)

# Package Outline Drawing

## M8.15E

### 8 LEAD NARROW BODY SMALL OUTLINE PLASTIC PACKAGE

Rev 0, 08/09



NOTES:

1. Dimensions are in millimeters.  
Dimensions in ( ) for Reference Only.
2. Dimensioning and tolerancing conform to AMSE Y14.5m-1994.
3. Unless otherwise specified, tolerance : Decimal ± 0.05
4. Dimension does not include interlead flash or protrusions.  
Interlead flash or protrusions shall not exceed 0.25mm per side.
5. The pin #1 identifier may be either a mold or mark feature.
6. Reference to JEDEC MS-012.

Компания «Life Electronics» занимается поставками электронных компонентов импортного и отечественного производства от производителей и со складов крупных дистрибьюторов Европы, Америки и Азии.

С конца 2013 года компания активно расширяет линейку поставок компонентов по направлению коаксиальный кабель, кварцевые генераторы и конденсаторы (керамические, пленочные, электролитические), за счёт заключения дистрибьюторских договоров

Мы предлагаем:

- Конкурентоспособные цены и скидки постоянным клиентам.
- Специальные условия для постоянных клиентов.
- Подбор аналогов.
- Поставку компонентов в любых объемах, удовлетворяющих вашим потребностям.
- Приемлемые сроки поставки, возможна ускоренная поставка.
- Доставку товара в любую точку России и стран СНГ.
- Комплексную поставку.
- Работу по проектам и поставку образцов.
- Формирование склада под заказчика.
- Сертификаты соответствия на поставляемую продукцию (по желанию клиента).
- Тестирование поставляемой продукции.
- Поставку компонентов, требующих военную и космическую приемку.
- Входной контроль качества.
- Наличие сертификата ISO.

В составе нашей компании организован Конструкторский отдел, призванный помогать разработчикам, и инженерам.

Конструкторский отдел помогает осуществить:

- Регистрацию проекта у производителя компонентов.
- Техническую поддержку проекта.
- Защиту от снятия компонента с производства.
- Оценку стоимости проекта по компонентам.
- Изготовление тестовой платы монтаж и пусконаладочные работы.



Тел: +7 (812) 336 43 04 (многоканальный)  
Email: [org@lifeelectronics.ru](mailto:org@lifeelectronics.ru)