

ISL95852

Integrated Power Management IC for IMVP8™ Platforms

FN8731
Rev 1.00
May 5, 2016

The [ISL95852](#) is a Power Management Integrated Circuit (PMIC) for ultrabook, notebook and tablet computers powered by 2-cell Li-ion batteries. It integrates control, MOSFET drivers, power MOSFETs, fault protection and fault monitoring functions for three highly efficient synchronous buck regulators. Integrated into one package are the regulators for the core, graphics and system agent voltages. The ISL95852 is offered in a thermally efficient 4mmx4mm, 64 bump, 0.5mm pitch WLCSP package.

The PMIC regulators convert the system voltage from a battery or adapter into the three necessary processor voltages required by Intel's IMVP8 specifications. The switching regulators operate at high frequency and are based on Intersil's proprietary R3™ Technology, which provides high light-load efficiency and fast transient response with minimal external compensation.

The PMIC provides overcurrent, overvoltage and over-temperature fault protections. Also provided is a temperature alert signal indicating the PMIC is operating at elevated temperature and an ALERT signal indicates if any other fault or warning has occurred. The PMIC also offers I²C capability compatible with Intel's SMBus specification.

Features

- Highly integrated power management IC
- Efficient high frequency integrated FET switching regulators
- Integrated regulators to produce core, graphics and system agent rails
- Extensive fault protection
 - Overcurrent, overvoltage and over-temperature protection
 - Temperature alert signal
- SVID I²C bus allows system fault monitoring, enable control
- Output voltage offset programming through SVID I²C

Applications

- Ultrabook, notebook and tablet computers

Related Literature

- [TB451](#), "PCB Assembly Guidelines for Intersil Wafer Level Chip Scale Package Devices"
- [TB500](#), "Computing Power Reference Design Adaptation Guide"
- [TB501](#), "Computing Power Regulator Layout Checklist"
- [UG041](#), "ISL95852EVAL1Z Evaluation Board User Guide"

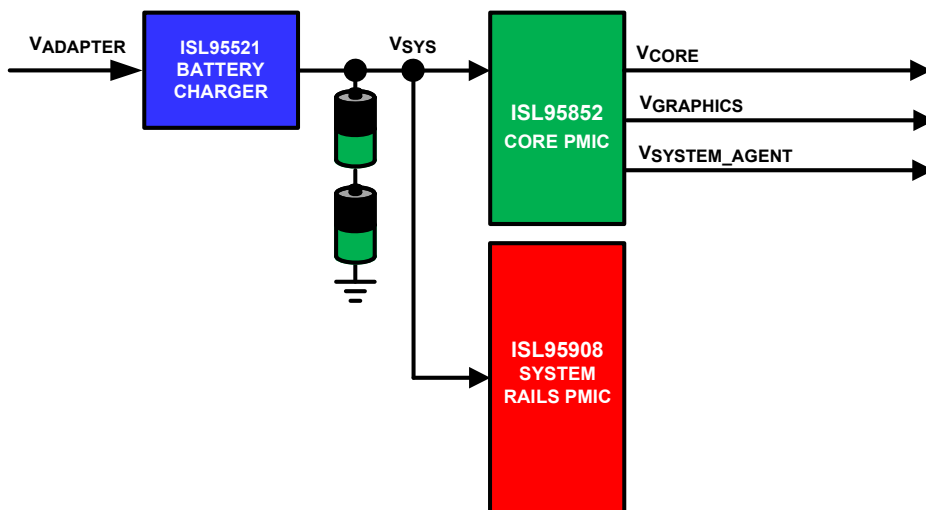

FIGURE 1. COMPUTER SYSTEM POWER MANAGEMENT SOLUTION

© Copyright Intersil Americas LLC 2015-2016. All Rights Reserved.
All trademarks and registered trademarks are the property of their respective owners.

For additional products, see www.intersil.com/en/products.html

Intersil products are manufactured, assembled and tested utilizing ISO9001 quality systems as noted in the quality certifications found at www.intersil.com/en/support/qualandreliability.html

Intersil products are sold by description only. Intersil may modify the circuit design and/or specifications of products at any time without notice, provided that such modification does not, in Intersil's sole judgment, affect the form, fit or function of the product. Accordingly, the reader is cautioned to verify that datasheets are current before placing orders. Information furnished by Intersil is believed to be accurate and reliable. However, no responsibility is assumed by Intersil or its subsidiaries for its use; nor for any infringements of patents or other rights of third parties which may result from its use. No license is granted by implication or otherwise under any patent or patent rights of Intersil or its subsidiaries.

For information regarding Intersil Corporation and its products, see www.intersil.com

Компания «Life Electronics» занимается поставками электронных компонентов импортного и отечественного производства от производителей и со складов крупных дистрибьюторов Европы, Америки и Азии.

С конца 2013 года компания активно расширяет линейку поставок компонентов по направлению коаксиальный кабель, кварцевые генераторы и конденсаторы (керамические, пленочные, электролитические), за счёт заключения дистрибьюторских договоров

Мы предлагаем:

- Конкурентоспособные цены и скидки постоянным клиентам.
- Специальные условия для постоянных клиентов.
- Подбор аналогов.
- Поставку компонентов в любых объемах, удовлетворяющих вашим потребностям.
- Приемлемые сроки поставки, возможна ускоренная поставка.
- Доставку товара в любую точку России и стран СНГ.
- Комплексную поставку.
- Работу по проектам и поставку образцов.
- Формирование склада под заказчика.
- Сертификаты соответствия на поставляемую продукцию (по желанию клиента).
- Тестирование поставляемой продукции.
- Поставку компонентов, требующих военную и космическую приемку.
- Входной контроль качества.
- Наличие сертификата ISO.

В составе нашей компании организован Конструкторский отдел, призванный помогать разработчикам, и инженерам.

Конструкторский отдел помогает осуществить:

- Регистрацию проекта у производителя компонентов.
- Техническую поддержку проекта.
- Защиту от снятия компонента с производства.
- Оценку стоимости проекта по компонентам.
- Изготовление тестовой платы монтаж и пусконаладочные работы.



Тел: +7 (812) 336 43 04 (многоканальный)

Email: org@lifeelectronics.ru

www.lifeelectronics.ru