

192MHz – 400MHz Low Phase Noise PECL XO (12 – 25MHz Crystal)

FEATURES

- Low phase noise output for the 192MHz to 400MHz range (-134 dBc at 10kHz offset).
- PECL output.
- 12 to 25MHz crystal input.
- Integrated crystal load capacitor: no external load capacitor required.
- Output Enable selector.
- 3.3V operation.
- Available in 16 Pin TSSOP.

PIN CONFIGURATION

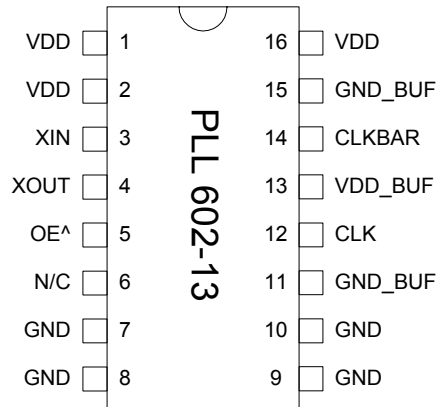

Note: ^ denotes internal pull up

$$F_{OUT} = F_{XIN} \times 16$$

DESCRIPTION

The PLL602-13 is a monolithic low jitter and low phase noise (-134dBc/Hz @ 10kHz offset) XO IC with PECL output, for 192MHz to 400MHz output range. It provides a low phase noise reference frequency using a low cost crystal.

The chip delivers an output frequency of $F_{XIN} \times 16$. This makes the PLL602-13 ideal for a wide range of applications.

OE (Pin 5)	Output State
0	Tri-state
1 (Default)	Output enabled

BLOCK DIAGRAM

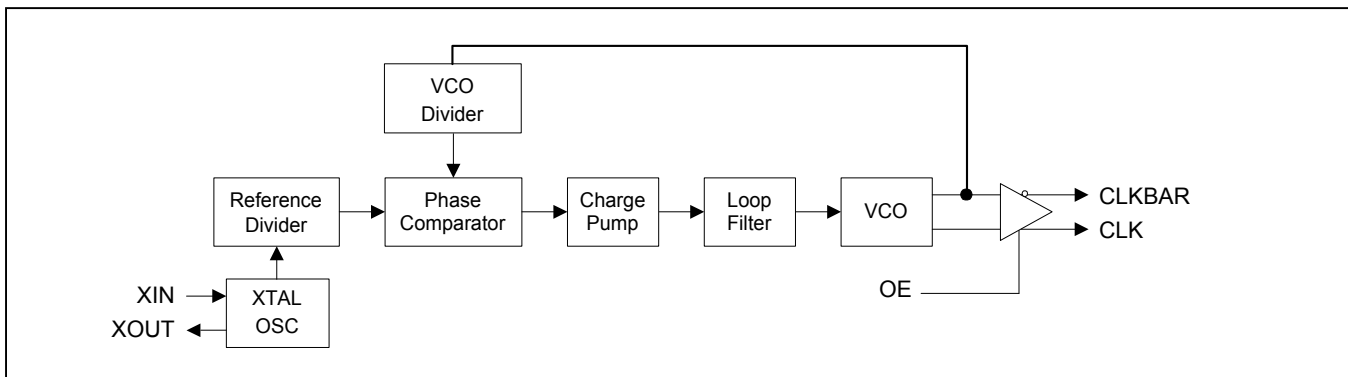

192MHz – 400MHz Low Phase Noise PECL XO (12 – 25MHz Crystal)

PIN DESCRIPTIONS

Name	Number	Type	Description
VDD	1,2,16	P	Power supply.
XIN	3	I	Crystal input. See Crystal Specifications on page 2.
XOUT	4	I	Crystal output. See Crystal Specifications on page 2.
OE	5	I	Output enable input. Disables (tri-state) output when low. Internal pull-up enables output by default if pin is not connected to low.
N/C	6	-	Not connected.
GND	7,8,9,10	P	Ground.
GND_BUF	11,15	P	Ground for output buffers.
CLK	12	O	True clock output.
VDD_BUF	13	P	Power supply for output buffers.
CLKB	14	O	Complementary clock output.

ELECTRICAL SPECIFICATIONS

1. Absolute Maximum Ratings

PARAMETERS	SYMBOL	MIN.	MAX.	UNITS
Supply Voltage	V_{DD}		4.6	V
Input Voltage, dc	V_I	-0.5	$V_{DD}+0.5$	V
Output Voltage, dc	V_O	-0.5	$V_{DD}+0.5$	V
Storage Temperature	T_S	-65	150	°C
Ambient Operating Temperature*	T_A	-40	85	°C
Junction Temperature	T_J		125	°C
Lead Temperature (soldering, 10s)			260	°C
ESD Protection, Human Body Model			2	kV

Exposure of the device under conditions beyond the limits specified by Maximum Ratings for extended periods may cause permanent damage to the device and affect product reliability. These conditions represent a stress rating only, and functional operations of the device at these or any other conditions above the operational limits noted in this specification is not implied.

* Note: Operating Temperature is guaranteed by design for all parts (COMMERCIAL and INDUSTRIAL), but tested for COMMERCIAL grade only.

2. Crystal Specifications

PARAMETERS	SYMBOL	CONDITIONS	MIN.	TYP.	MAX.	UNITS
Crystal Resonator Frequency	F_{XIN}	Parallel Fundamental Mode	12		25	MHz
Crystal Loading Rating	C_L (xtal)			20		pF
Recommended ESR	R_E	AT cut			30	Ω

192MHz – 400MHz Low Phase Noise PECL XO (12 – 25MHz Crystal)

3. General Electrical Specifications

PARAMETERS	SYMBOL	CONDITIONS	MIN.	TYP.	MAX.	UNITS
Supply Current, Dynamic (with Loaded Outputs)	I _{DD}	PECL			80	mA
Operating Voltage	V _{DD}		2.97		3.63	V
Output Clock Duty Cycle		@ V _{DD} – 1.3V (PECL)	45	50	55	%
Short Circuit Current				±50		mA

4. Jitter and Phase Noise Specification

PARAMETERS	CONDITIONS	MIN.	TYP.	MAX.	UNITS
Period jitter RMS	With capacitive decoupling between VDD and GND.		5		ps
Accumulated jitter RMS	With capacitive decoupling between VDD and GND. Over 10,000 cycles.		11		ps
Phase Noise relative to carrier	311MHz @100Hz offset		-90		dBc/Hz
Phase Noise relative to carrier	311MHz @1kHz offset		-115		dBc/Hz
Phase Noise relative to carrier	311MHz @10kHz offset		-125		dBc/Hz
Phase Noise relative to carrier	311MHz @100kHz offset		-119		dBc/Hz

192MHz – 400MHz Low Phase Noise PECL XO (12 – 25MHz Crystal)

5. PECL Electrical Characteristics

PARAMETERS	SYMBOL	CONDITIONS	MIN.	MAX.	UNITS
Output High Voltage	V_{OH}	$R_L = 50 \Omega$ to $(V_{DD} - 2V)$ (see figure)	$V_{DD} - 1.025$		V
Output Low Voltage	V_{OL}			$V_{DD} - 1.620$	V

6. PECL Switching Characteristics

PARAMETERS	SYMBOL	CONDITIONS	MIN.	TYP.	MAX.	UNITS
Clock Rise Time	t_r	@20/80% - PECL		0.6	1.5	ns
Clock Fall Time	t_f	@80/20% - PECL		0.5	1.5	ns

PECL Levels Test Circuit

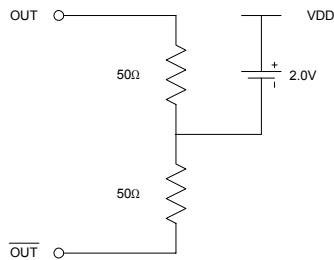

PECL Output Skew

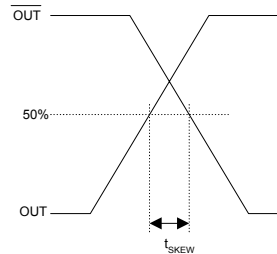

PECL Transition Time Waveform

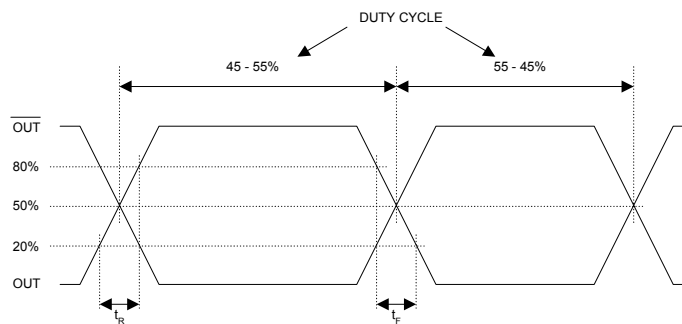

192MHz – 400MHz Low Phase Noise PECL XO (12 – 25MHz Crystal)

PACKAGE INFORMATION

16 PIN TSSOP (mm)		
Symbol	Min.	Max.
A	-	1.20
A1	0.05	0.15
B	0.19	0.30
C	0.09	0.20
D	4.90	5.10
E	4.30	4.50
H	6.40 BSC	
L	0.45	0.75
e	0.65 BSC	

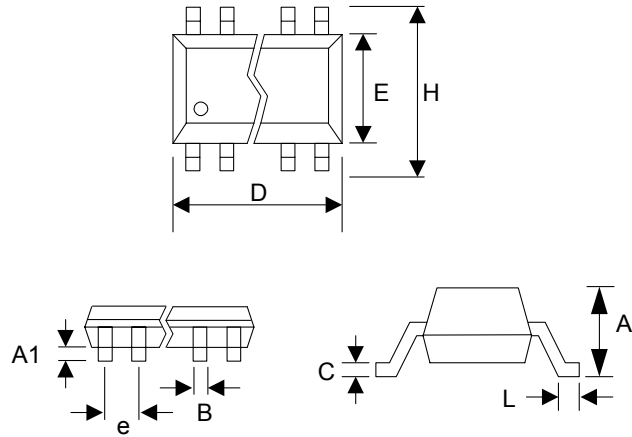

ORDERING INFORMATION

For part ordering, please contact our Sales Department:

47745 Fremont Blvd., Fremont, CA 94538, USA
Tel: (510) 492-0990 Fax: (510) 492-0991

PART NUMBER

The order number for this device is a combination of the following:
Device number, Package type and Operating temperature range

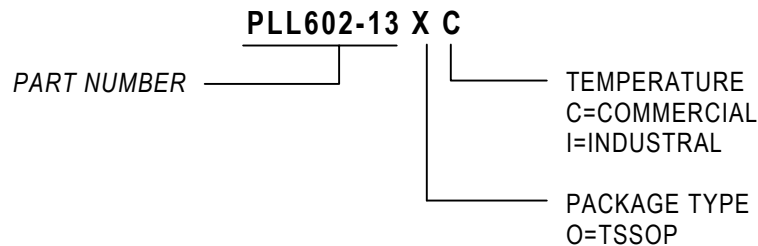

<u>Order Number</u>	<u>Marking</u>	<u>Package Option</u>
PLL602-13OC	P602-13OC	TSSOP – Tube
PLL602-13OC-R	P602-13OC	TSSOP - Tape and Reel

PhaseLink Corporation, reserves the right to make changes in its products or specifications, or both at any time without notice. The information furnished by Phaselink is believed to be accurate and reliable. However, PhaseLink makes no guarantee or warranty concerning the accuracy of said information and shall not be responsible for any loss or damage of whatever nature resulting from the use of, or reliance upon this product.

LIFE SUPPORT POLICY: PhaseLink’s products are not authorized for use as critical components in life support devices or systems without the express written approval of the President of PhaseLink Corporation.

Компания «Life Electronics» занимается поставками электронных компонентов импортного и отечественного производства от производителей и со складов крупных дистрибьюторов Европы, Америки и Азии.

С конца 2013 года компания активно расширяет линейку поставок компонентов по направлению коаксиальный кабель, кварцевые генераторы и конденсаторы (керамические, пленочные, электролитические), за счёт заключения дистрибьюторских договоров

Мы предлагаем:

- Конкурентоспособные цены и скидки постоянным клиентам.
- Специальные условия для постоянных клиентов.
- Подбор аналогов.
- Поставку компонентов в любых объемах, удовлетворяющих вашим потребностям.
- Приемлемые сроки поставки, возможна ускоренная поставка.
- Доставку товара в любую точку России и стран СНГ.
- Комплексную поставку.
- Работу по проектам и поставку образцов.
- Формирование склада под заказчика.
- Сертификаты соответствия на поставляемую продукцию (по желанию клиента).
- Тестирование поставляемой продукции.
- Поставку компонентов, требующих военную и космическую приемку.
- Входной контроль качества.
- Наличие сертификата ISO.

В составе нашей компании организован Конструкторский отдел, призванный помогать разработчикам, и инженерам.

Конструкторский отдел помогает осуществить:

- Регистрацию проекта у производителя компонентов.
- Техническую поддержку проекта.
- Защиту от снятия компонента с производства.
- Оценку стоимости проекта по компонентам.
- Изготовление тестовой платы монтаж и пусконаладочные работы.



Тел: +7 (812) 336 43 04 (многоканальный)

Email: org@lifeelectronics.ru