



19.6W Single Port Power over Ethernet Midspan IEEE802.3af Compliant Power Injector



Features

- Compliant with IEEE802.3af Standard
- Non-vented Case
- Full Protection OVP, OCP
- Limited Power Source
- Gigabit Compatible
- 1 Year Warranty

Applications

- IP Telephones
- Wireless Access Points
- Bluetooth® Access Points
- Security Cameras
- IP Print Servers
- WiMAX® Access Points

Safety Approvals

- cUL/UL
- CE

Mechanical Characteristics

- Length: 140mm (5.51in.)
- Width: 65mm (2.55in.)
- Height: 36mm (1.42in.)
- Weight: 0.2Kg (7.58oz)

Output Specifications

Model	AC Input	DC Output Voltage	Load		Regulation	
			Min.	Max.	Line	Load
POE21U-1AF-R ¹	Three Wire	56V	10mA	350mA	54-57V	

Notes: (1) Consult factory for availability

Phihong is not responsible for any error, and reserves the right to make changes without notice. Please visit our website at www.phihong.com for the most up-to-date specifications and contact information.

INPUT:

AC Input Voltage Rating

100 to 240VAC

AC Input Voltage Range

90 to 264VAC

AC Input Current

0.8A (RMS) max at 120VAC

0.55A (RMS) max at 240VAC

AC Input Frequency

47 to 63Hz

Leakage Current

350uA max

Max In-rush Current

60A max at 240VAC and max load
(Cold Start at ambient 25°C)

OUTPUT:

Output Power

19.6W

Hold up Time

10mSec min at max load at 120VAC, 60Hz

Transient O/P Voltage Protection

60V max at switch on/off any AC line phase

Efficiency

80% Typical at max load at 120VAC, 60Hz

ENVIRONMENTAL:

Temperature

Operating 0 to +40°C

Non-operating -20 to +65°C

Humidity 5 to 90%

EMI

Complies with FCC part 15 Class B

Complies with EN55032 Class B

EMC

ESD: IEC61000-4-2 Level 3

RS: IEC61000-4-3 Level 3

EFT/Burst: IEC61000-4-4 Level 2

Surge: IEC61000-4-5 Level 3

CS: IEC61000-4-6 Level3

Voltage Dips: IEC61000-4-11

Harmonic: IEC61000-3-2 Class A

Isolation (HI-POT)

Primary to secondary: 1500VAC for 1 minute, 10mA

Insulation Resistance

Primary to secondary: 10M Ohm 500VDC

FEATURES:

Cisco

No extern parts required for Legacy devices:

VoIP Phones: 7910, 7912, 7940, 7960

Access Points: 1040, 1140, 1250, 1260,3500

Over Voltage/Current, Short Circuit Protection

The output can be shorted permanently without damage.

Indicator (Status)

Solid Green: Valid IEEE802.3af load detected and connected "ON"

Blinking Green: Power "ON" ready for connection

Blinking Red/Green: Invalid load connected

Blinking Red: fault

AC Input Connector

IEC320 inlet 3-pin C14

Output Connection

+pins 3,6 / -pins 1,2

Data IN/POE OUT Connector

RJ45

Dimension Diagram Unit: mm

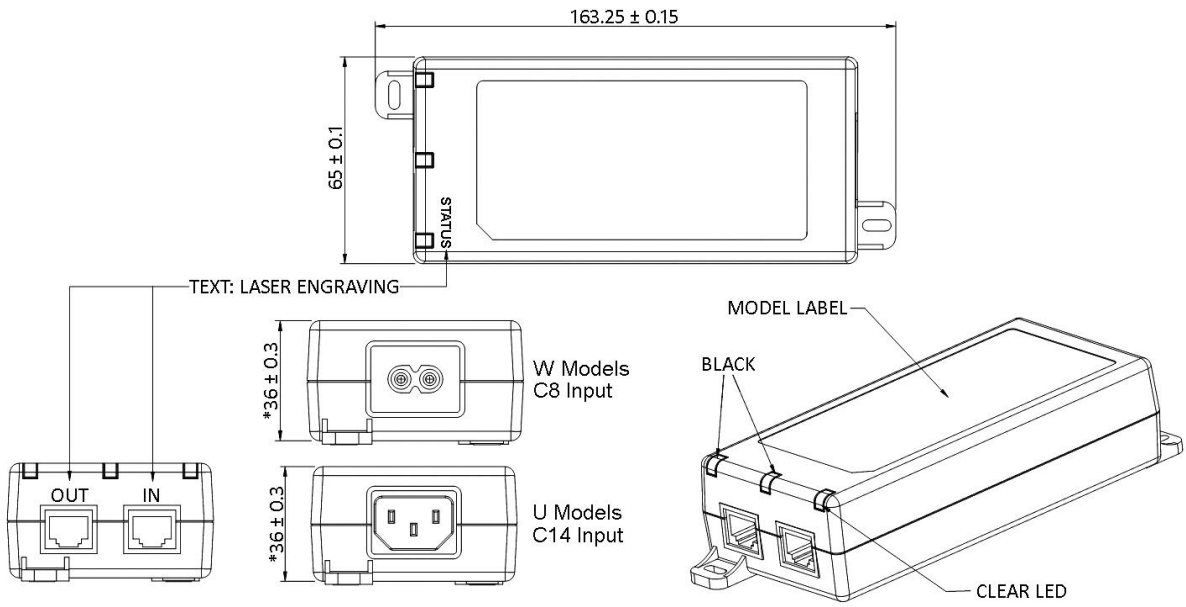

Supplier's Declaration of Conformity
47 CFR § 2.1077 Compliance Information

Phihong USA Corporation
47800 Fremont Boulevard
Fremont, CA 94538
Telephone: (510) 445-0100
www.phihong.com

NOTE: This model has/The models in this product series have been tested and found to comply with the limits for a Class B digital device, pursuant to part 15 of the FCC Rules. These limits are designed to provide reasonable protection against harmful interference in a residential installation. This equipment generates, uses and can radiate radio frequency energy and, if not installed and used in accordance with the instructions, may cause harmful interference to radio communications. However, there is no guarantee that interference will not occur in a particular installation. If this equipment does cause harmful interference to radio or television reception, which can be determined by turning the equipment off and on, the user is encouraged to try to correct the interference by one or more of the following measures:

- Reorient or relocate the receiving antenna.
- Increase the separation between the equipment and receiver.
- Connect the equipment into an outlet on a circuit different from that to which the receiver is connected.
- Consult the dealer or an experienced radio/TV technician for help.

Changes or modifications to equipment not expressly approved by PHIHONG could void the user's authority to operate the equipment.

Компания «Life Electronics» занимается поставками электронных компонентов импортного и отечественного производства от производителей и со складов крупных дистрибьюторов Европы, Америки и Азии.

С конца 2013 года компания активно расширяет линейку поставок компонентов по направлению коаксиальный кабель, кварцевые генераторы и конденсаторы (керамические, пленочные, электролитические), за счёт заключения дистрибьюторских договоров

Мы предлагаем:

- Конкурентоспособные цены и скидки постоянным клиентам.
- Специальные условия для постоянных клиентов.
- Подбор аналогов.
- Поставку компонентов в любых объемах, удовлетворяющих вашим потребностям.
- Приемлемые сроки поставки, возможна ускоренная поставка.
- Доставку товара в любую точку России и стран СНГ.
- Комплексную поставку.
- Работу по проектам и поставку образцов.
- Формирование склада под заказчика.
- Сертификаты соответствия на поставляемую продукцию (по желанию клиента).
- Тестирование поставляемой продукции.
- Поставку компонентов, требующих военную и космическую приемку.
- Входной контроль качества.
- Наличие сертификата ISO.

В составе нашей компании организован Конструкторский отдел, призванный помогать разработчикам, и инженерам.

Конструкторский отдел помогает осуществить:

- Регистрацию проекта у производителя компонентов.
- Техническую поддержку проекта.
- Защиту от снятия компонента с производства.
- Оценку стоимости проекта по компонентам.
- Изготовление тестовой платы монтаж и пусконаладочные работы.



Тел: +7 (812) 336 43 04 (многоканальный)
Email: org@lifeelectronics.ru