



EVALUATION BOARD FOR Si5017 SiPHY™ SONET/SDH CLOCK AND DATA RECOVERY IC

Description

The Si5017 evaluation board provides a platform for testing and characterizing Silicon Laboratories' Si5017 SiPHY™ SONET/SDH clock and data recovery IC. The Si5017 CDR supports OC-48, STM-16, and 2.7 Gbps FEC rates.

All high-speed I/Os are ac coupled to ease interfacing to industry standard test equipment.

Features

- Single 3.3 V power supply
- Differential I/Os ac coupled
- Simple jumper configuration

Functional Block Diagram

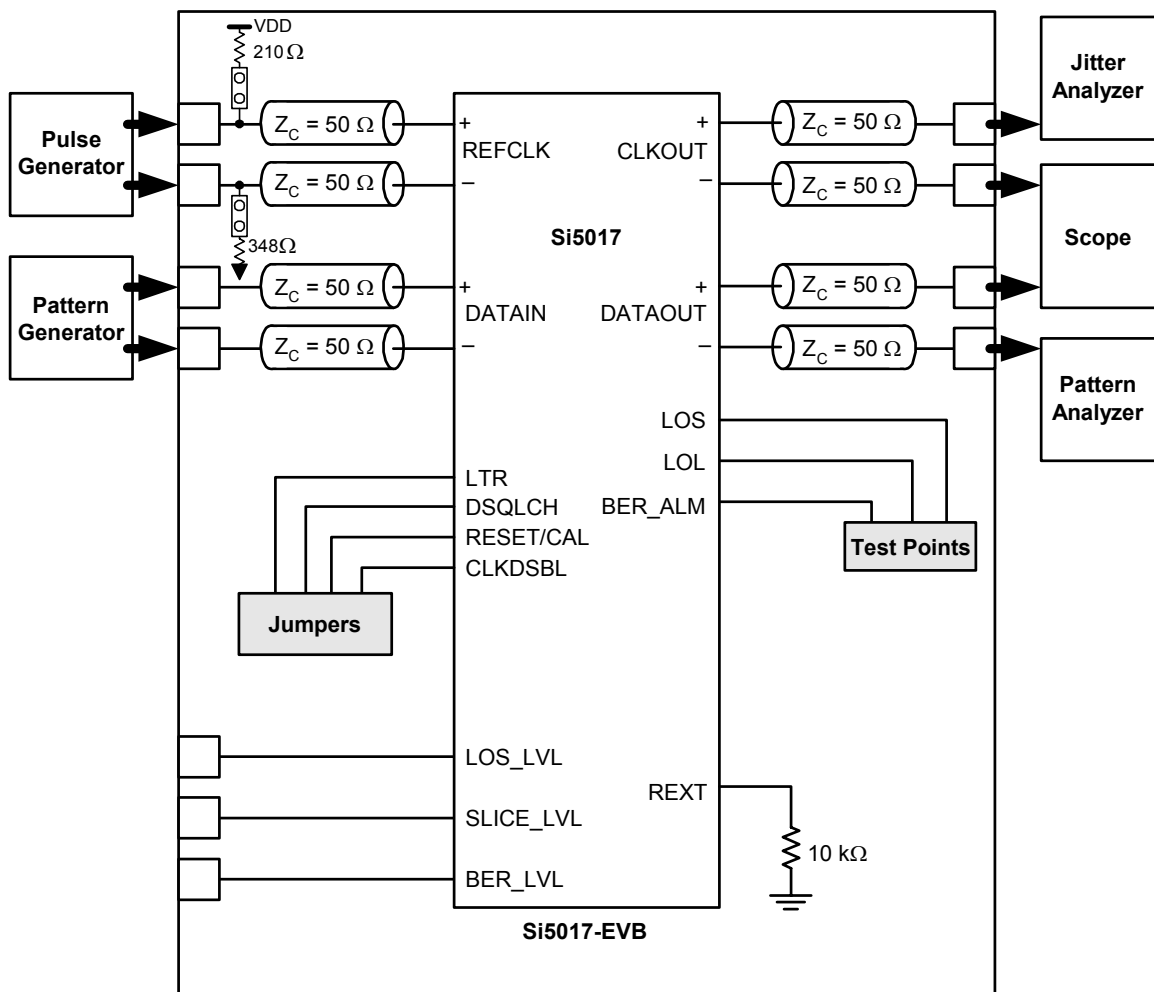

Functional Description

The evaluation board simplifies characterization of the Si5017 Clock and Data Recovery (CDR) device by providing access to all of the Si5017 I/Os. Device performance can be evaluated by following the “Test Configuration” section. Specific performance metrics include input sensitivity, jitter tolerance, jitter generation, and jitter transfer.

Power Supply

The evaluation board requires one 3.3 V supply. Supply filtering is placed on the board to filter typical system noise components; however, initial performance testing should use a linear supply capable of supplying the nominal voltage $\pm 5\%$ dc.

CAUTION: The evaluation board is designed so that the body of the SMA jacks and GND are shorted. Care must be taken when powering the PCB at potentials other than GND at 0.0 V and VDD at 3.3 V relative to chassis GND.

Device Powerdown

The CDR can be powered down via the RESET/CAL signal. When asserted, the evaluation board draws minimal current. RESET/CAL is controlled via one jumper located in the lower left-hand corner of the evaluation board. RESET/CAL is wired to the signal post adjacent to the VDD post. For a valid reset to occur when using external reference clock mode, a proper external reference clock frequency must be applied as specified in Table 1. CLKOUT, DATAOUT, DATAIN, CLKOUT, DATAOUT, and DATAIN (all high-speed I/Os) are wired to the board perimeter on 30 mil (0.030 inch) 50 Ω microstrip lines to the end-launch SMA jacks as labeled on the PCB. These I/Os are ac coupled to simplify direct connection to a wide array of standard test hardware. Because each of these signals are differential, both the positive (+) and negative (–) terminals must be terminated to 50 Ω . Terminating only one side will adversely degrade the performance of the CDR. The inputs are terminated on the die with 50 Ω resistors.

Note: The 50 Ω termination is for each terminal/side of a differential signal, thus the differential termination is actually 50 Ω + 50 Ω = 100 Ω .

REFCLK

REFCLK is optional for clock and data recovery within the Si5017 device. If REFCLK is not used, jumper both JP15 and JP16. These jumpers pull the REFCLK+ input to VDD and REFCLK– input to GND, which configures the device to operate without an external reference.

When applied, REFCLK is used to center the frequency of the DSPLL™ so the device can lock to the data. Ideally, the REFCLK frequency should be 1/128th, 1/32nd, or 1/16th the VCO frequency and must have a frequency accuracy of ± 100 ppm. Internally, the CDR automatically recognizes the REFCLK frequency within one of these three frequency ranges. Typical REFCLK frequencies are given in Table 1. REFCLK is ac coupled to the SMA jacks located on the top side of the evaluation board.

Table 1. Typical REFCLK Frequencies

SONET/SDH	SONET/SDH with 15/14 FEC	Ratio of VCO to REFCLK
19.44 MHz	20.83 MHz	128
77.76 MHz	83.31 MHz	32
155.52 MHz	166.63 MHz	16

Loss-of-Lock (LOL)

Loss-of-lock (LOL) is an indicator of the relative frequency between the data and the REFCLK. LOL asserts when the frequency difference is greater than ± 600 ppm. To prevent LOL from de-asserting prematurely, there is hysteresis in returning from the out-of-lock condition. LOL will be de-asserted when the frequency difference is less than ± 300 ppm.

LOL is wired to a test point which is located on the upper right-hand side of the evaluation board.

Loss-of-Signal Alarm Threshold Control

The loss-of-signal alarm (LOS) is used to signal low incoming data amplitude levels. The programmable threshold control is set by applying a dc voltage level from a low noise voltage source to the LOS_LVL pin. The LOS_LVL is controllable through the BNC jack J10. The mapping of the LOS_LVL voltage to input signal alarm threshold level is shown in Figure 1. The LOS Threshold to LOS Level is mapped as follows:

$$V_{\text{LOS}} = \frac{V_{\text{LOS_LVL}} - 1.5}{25}$$

If this function is not used, install jumper to JP1 header.

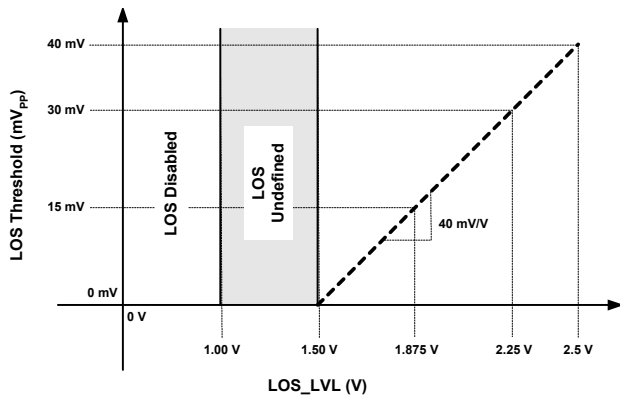

Figure 1. LOS_LVL Mapping

Extended LOS Hysteresis Option

An optional LOS Hysteresis Extension circuit is included on the Si5017-EVB to provide a convenient means of increasing the amount of $\overline{\text{LOS}}$ Alarm hysteresis when testing and evaluating the Si5017 $\overline{\text{LOS}}$ functionality. This simple network will extend the $\overline{\text{LOS}}$ hysteresis to approximately 6 dB, thereby preventing unnecessary switching on $\overline{\text{LOS}}$ for low level DATAIN signals in the range of 20 mV_{PPD}. Hysteresis is defined as the ratio of the $\overline{\text{LOS}}$ deassert level (LOSD) and the $\overline{\text{LOS}}$ assert level (LOSA). The hysteresis in decibels is calculated as $20\log(\text{LOSD}/\text{LOSA})$. This circuit is constructed with one CMOS inverter (U2) and two resistors (R12, R13) mounted on the underside of the PCB. If desired, this circuit can be enabled by installing a jumper on JP17 (HYST ENABLE) located near the power entry block.

Data Slicing Level

The slicing level allows optimization of the input cross-over point for systems where the slicing level is not at the amplitude average. The data slicing level can be adjusted from the nominal cross-over point of the data by applying a voltage to the SLICE_LVL pin. SLICE_LVL is controllable through the BNC jack J11. The SLICE_LVL to the data slicing level is mapped as follows:

$$V_{\text{SLICE}} = \frac{V_{\text{SLICE_LVL}} - 1.5}{50}$$

If this function is not used, jumper JP6.

Bit-Error-Rate Alarm Threshold

The bit-error-rate of the incoming data can be monitored by the BER_ALM pin. When the bit-error-rate exceeds an externally set threshold level, BER_ALM is asserted. BER_ALM is brought to a test point located in the upper right-hand corner of the board. The BER_ALM threshold

level is set by applying a dc voltage to the BER_LVL pin. BER_LVL is controllable through the BNC jack J12. Jumper JP7 to disable the BER alarm. Refer to the "BER Detection" section of the Si5016/Si5017 data sheet for threshold level programming.

Test Configuration

The three critical jitter tests typically performed on a CDR device are jitter transfer, jitter tolerance, and jitter generation. By connecting the Si5017 Evaluation Board as shown in Figure 2, all three measurements can be easily made.

When applied, REFCLK should be within ± 100 ppm of the frequency selected from Table 1 and RESET/CAL must be unjumpered.

Jitter Tolerance: Referring to Figure 2, this test requires a pattern generator, a clock source (synthesizer signal source), a modulation source, a jitter analyzer, a pattern analyzer, and a pulse generator (all unconnected high-speed outputs must be terminated to 50 Ω). During this test, the Jitter Analyzer directs the Modulation Source to apply prescribed amounts of jitter to the synthesizer source. This "jitters" the pattern generator timebase which drives the DATAIN ports of the CDR. The Bit-Error-Rate (BER) is monitored on the Pattern Analyzer. The modulation (jitter) frequency and amplitude is recorded when the BER approaches a specified threshold. The Si5017 limiting amplifier can also be examined during this test. Simply lower the amplitude of the incoming data to the minimum value typically expected at the limiting amplifier inputs (typically 10 mV_{PP} for the Si5017 device).

Jitter Generation: Referring to Figure 2, this test requires a pattern generator, a clock source (synthesizer signal source), a jitter analyzer, and a pulse generator (all unconnected high-speed outputs must be terminated to 50 Ω). During this test, there is no modulation of the Data Clock, so the data that is sent to the CDR is jitter free. The Jitter Analyzer measures the RMS and peak-to-peak jitter on the CDR CLKOUT. Thus, any jitter measured is jitter generated by the CDR.

Jitter Transfer: Referring to Figure 2, this test requires a pattern generator, a clock source (synthesizer signal source), a modulation source, a jitter analyzer, and a pulse generator (all unconnected high-speed outputs must be terminated to 50 Ω). During this test, the Jitter Analyzer modulates the data pattern and data clock reference. The modulated data clock reference is compared with the CLKOUT of the CDR. Jitter on CLKOUT relative to the jitter on the data clock reference is plotted versus modulation frequency at predefined jitter amplitudes.

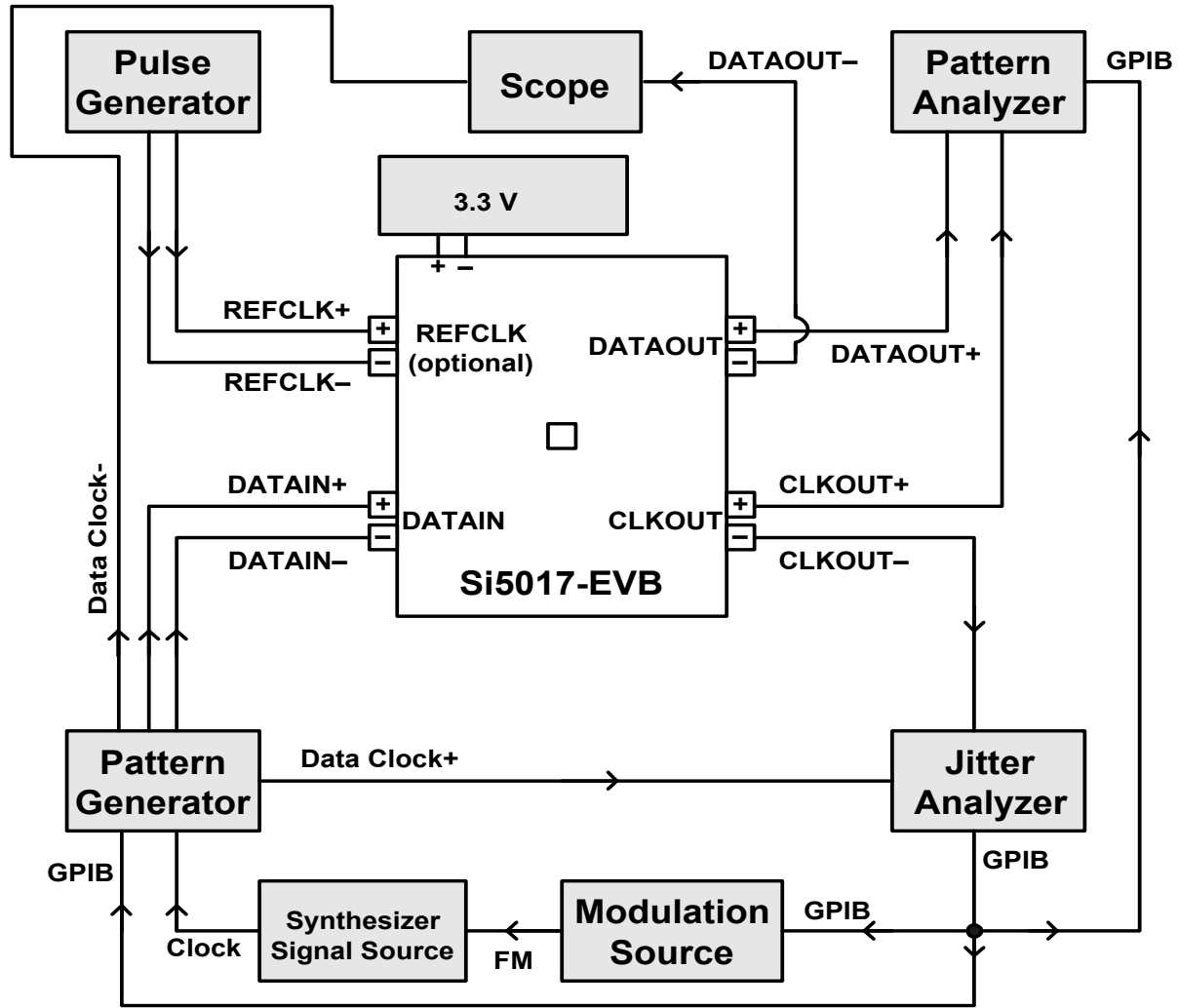

Figure 2. Test Configuration for Jitter Tolerance, Transfer, and Generation

Si5017-EVB

Bill of Materials

Si5017EVB Assy Rev B-01 BOM			2/8/2002
Reference	Description	Manufacturer's #	Manufacturer
C1,C2,C3,C4,C5,C6, C7,C8,C17,C18,C19, C20	CAP,SM,0.1UF,16V,20%,X7R,0603	C0603X7R160-104KNE	VENKEL
C12	CAP,SM,10UF,10V,10%,TANTALUM,3216	TA010TCM106KAR	VENKEL
C13,C14,C15,C16	CAP,SM,100PF,50V,10%,C0G,0603	C0603C0G500-101KNE	VENKEL
JP1,JP6,JP7,JP11, JP12,JP13,JP14, JP15,JP16,JP17	CONN,HEADER,2X1	2340-6111TN or 2380-6121TN	3M
JP2,JP3,JP5,JP8,	CONN,HEADER,3X1	2340-6111TN or 2380-6121TN	3M
J1,J2,J3,J4,J5,J6, J7,J8	CONN,SMA SIDE MOUNT	901-10003	AMPHENOL
J10,J11,J12	CONN,BNC,VERT	161-9317	MOUSER
J13	CONN,POWER,2 POSITION	1729018	PHOENIX CONTACT
L1	FERRITE,SM,600,1206	BLM31A601S	MURATA
R1,R13	RES,SM,10K,1%,0603	CR0603-16W-1002FT	VENKEL
R5	RES,SM,348,1%,0603	CR0603-16W-3480FT	VENKEL
R6	RES,SM,210,1%,0603	CR0603-16W-2100FT	VENKEL
R7	RES,SM,4.99K,1%,0603	CR0603-16W-4991FT	VENKEL
R8	RES,SM,100,1%,0603	CR0603-16W-1000FT	VENKEL
R10,R11	RES,SM,0,0603	CR0603-16W-000T	VENKEL
R12	RES,SM,806,1%,0603	CR0603-16W-8060FT	VENKEL
U1	Si5017 Rev B Device	Si5017-BM Rev B	SILICON LABORATORIES
U2	IC,SM,7SZ04,SINGLE GATE INVERTER,5 PIN SOT23	NC7SZ04M5X	FAIRCHILD
PCB	Printed Circuit Board	Si5017-EVB PCB Rev C	SILICON LABORATORIES
No Load			
R9	RES,SM,0,0603	CR0603-16W-000T	VENKEL
JP4,JP9,JP10	CONN,HEADER,3X1	2340-6111TN or 2380-6121TN	3M

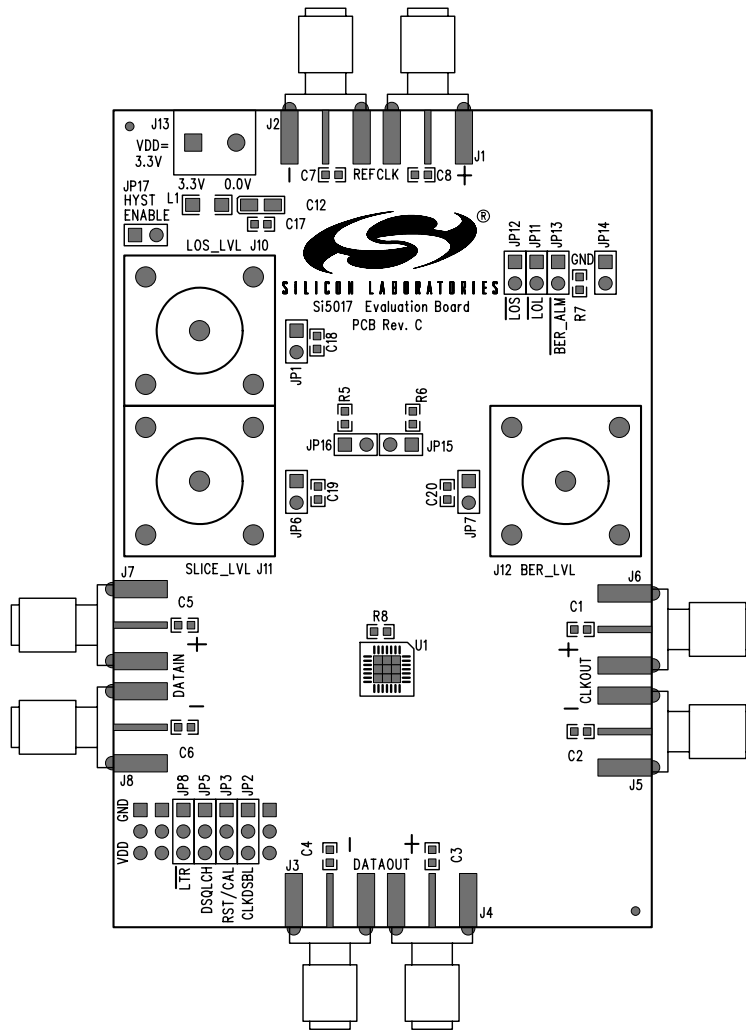

Figure 4. Si5017 Top View

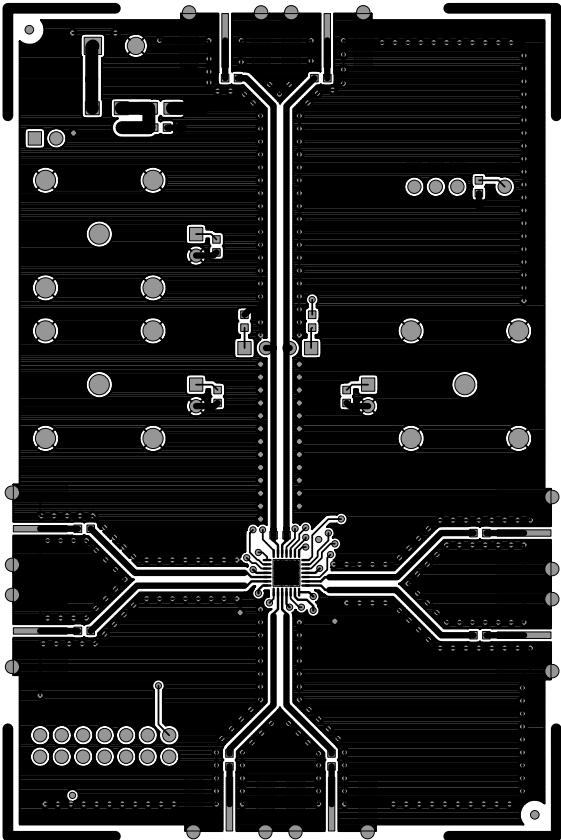

Figure 5. Si5017 Component Side

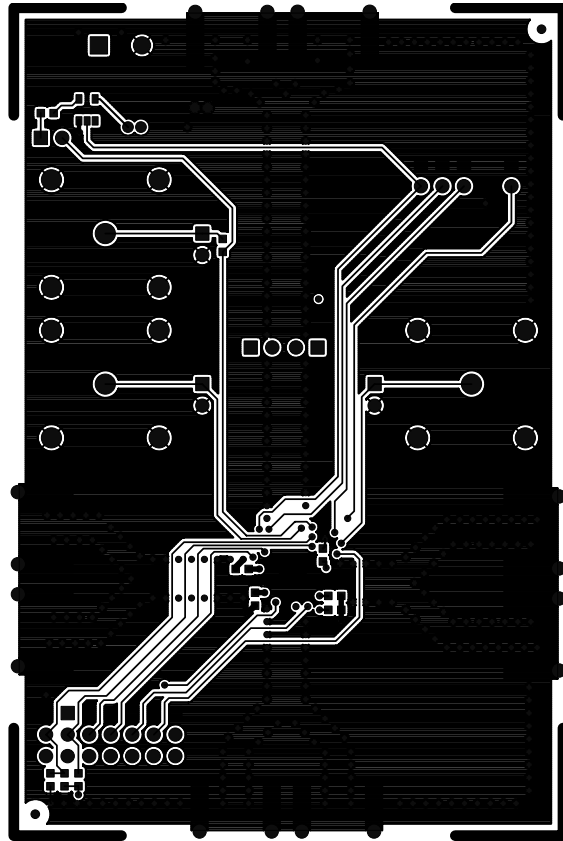

Figure 6. Si5017 Solder Side

Si5017-EVB

Document Change List

Revision 0.23 to Revision 1.0

- “Preliminary” language removed.

Evaluation Board Assembly Revision History

Assembly Level	PCB Rev.	Si5017 Rev.	Assembly Notes
B-01	Rev. C	Rev. B	Assemble per BOM rev B-01

Notes:

Contact Information

Silicon Laboratories Inc.
4635 Boston Lane
Austin, TX 78735
Tel: 1+(512) 416-8500
Fax: 1+(512) 416-9669
Toll Free: 1+(877) 444-3032
Email: productinfo@silabs.com
Internet: www.silabs.com

The information in this document is believed to be accurate in all respects at the time of publication but is subject to change without notice. Silicon Laboratories assumes no responsibility for errors and omissions, and disclaims responsibility for any consequences resulting from the use of information included herein. Additionally, Silicon Laboratories assumes no responsibility for the functioning of undescribed features or parameters. Silicon Laboratories reserves the right to make changes without further notice. Silicon Laboratories makes no warranty, representation or guarantee regarding the suitability of its products for any particular purpose, nor does Silicon Laboratories assume any liability arising out of the application or use of any product or circuit, and specifically disclaims any and all liability, including without limitation consequential or incidental damages. Silicon Laboratories products are not designed, intended, or authorized for use in applications intended to support or sustain life, or for any other application in which the failure of the Silicon Laboratories product could create a situation where personal injury or death may occur. Should Buyer purchase or use Silicon Laboratories products for any such unintended or unauthorized application, Buyer shall indemnify and hold Silicon Laboratories harmless against all claims and damages.

Silicon Laboratories, Silicon Labs, and SiPHY are trademarks of Silicon Laboratories Inc.

Other products or brandnames mentioned herein are trademarks or registered trademarks of their respective holders.

Компания «Life Electronics» занимается поставками электронных компонентов импортного и отечественного производства от производителей и со складов крупных дистрибьюторов Европы, Америки и Азии.

С конца 2013 года компания активно расширяет линейку поставок компонентов по направлению коаксиальный кабель, кварцевые генераторы и конденсаторы (керамические, пленочные, электролитические), за счёт заключения дистрибьюторских договоров

Мы предлагаем:

- Конкурентоспособные цены и скидки постоянным клиентам.
- Специальные условия для постоянных клиентов.
- Подбор аналогов.
- Поставку компонентов в любых объемах, удовлетворяющих вашим потребностям.
- Приемлемые сроки поставки, возможна ускоренная поставка.
- Доставку товара в любую точку России и стран СНГ.
- Комплексную поставку.
- Работу по проектам и поставку образцов.
- Формирование склада под заказчика.
- Сертификаты соответствия на поставляемую продукцию (по желанию клиента).
- Тестирование поставляемой продукции.
- Поставку компонентов, требующих военную и космическую приемку.
- Входной контроль качества.
- Наличие сертификата ISO.

В составе нашей компании организован Конструкторский отдел, призванный помогать разработчикам, и инженерам.

Конструкторский отдел помогает осуществить:

- Регистрацию проекта у производителя компонентов.
- Техническую поддержку проекта.
- Защиту от снятия компонента с производства.
- Оценку стоимости проекта по компонентам.
- Изготовление тестовой платы монтаж и пусконаладочные работы.



Тел: +7 (812) 336 43 04 (многоканальный)

Email: org@lifeelectronics.ru