



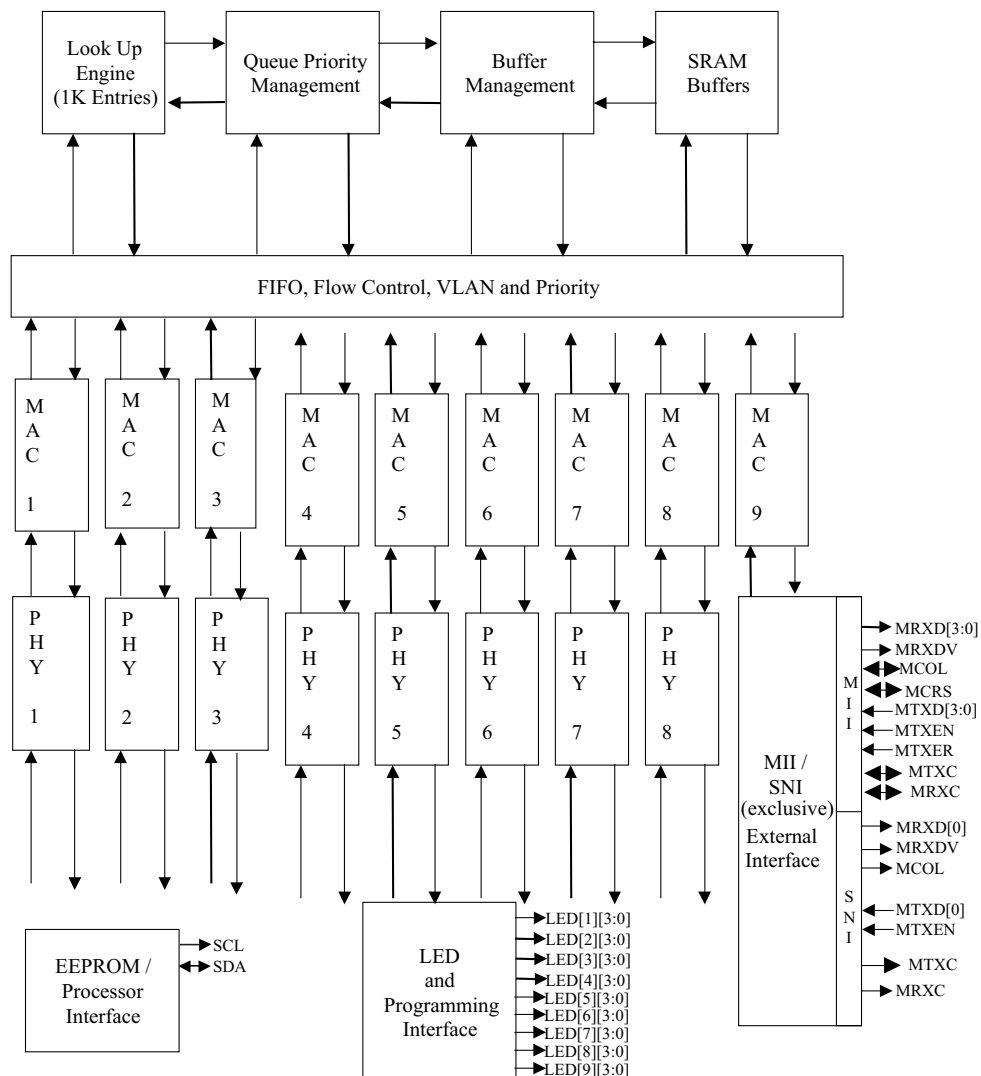
### General Description

The KS8999 contains eight 10/100 physical layer transceivers, nine MAC (Media Access Control) units with an integrated layer 2 switch. The device runs in two modes. The first mode is an eight port integrated switch and the second is as a nine port switch with the ninth port available through an MII (Media Independent Interface). Useful configurations include a stand alone eight port switch as well as a eight port switch with a routing element connected to the extra MII port. The additional port is also useful for a public network interfacing. The

KS8999 is designed to reside in an unmanaged design not requiring processor intervention. This is achieved through I/O strapping or EEPROM programming at system reset time. On the media side, the KS8999 supports 10BaseT, 100BaseTX and 100BaseFX as specified by the IEEE 802.3 committee. Physical signal transmission and reception are enhanced through use of analog circuitry that makes the design more efficient and allows for lower power consumption and smaller chip die size.

Data sheets and support documentation can be found on Micrel's web site at [www.micrel.com](http://www.micrel.com).

### Functional Diagram



## Features

- 9 port (8+1) 10/100 integrated switch with eight physical layer transceivers and one MII/SNI interface
- Advanced Ethernet Switch with internal frame buffer
  - 128K Byte of SRAM on chip for frame buffering
  - 2.0Gbps high performance memory bandwidth
  - Wire speed reception and transmission
  - Integrated address look-up engine, supports 1K absolute MAC addresses
  - Automatic address learning, address aging and address migration
- Advanced Switch Features
  - Supports 802.1p priority and port based priority
  - Supports port based VLAN
  - Supports 1536 byte frame for VLAN tag
  - Supports DiffServ priority, 802.1p based priority or port based priority and broadcast storm protection
- Proven transceiver technology for UTP and fiber operation
  - 10BaseT, 100BaseTX and 100BaseFX modes of operation
  - Supports for UTP or fiber on all 8-ports
  - Indicators for link, activity, full/half-duplex and speed
  - Hardware based 10/100, full/half, flow control and auto-negotiation
  - Individual port forced modes (full duplex, 100BaseTX) when auto-negotiation is disabled
  - Full duplex IEEE 802.3x flow control
  - Half-duplex back pressure flow control
- Supports MDI/MDI-X auto crossover
- External MAC interface (MII or 7-wire) for router applications
- Unmanaged operation via strapping or EEPROM at system reset time (see Reset Reference Circuit section)
- Comprehensive LED support
- Single 2.0V power supply with options for 2.5V and 3.3V I/O
- 900 mA (1.80W) including physical transmit drivers
- Supports both commercial and industry temperature
  - Commercial temperature range: 0°C to +70°C (KS8999)
  - Industrial temperature range: –40°C to +85°C (KS8999I)
- Supports lead free products:
  - Commercial temperature range: 0°C to +70°C (KSZ8999)
  - Industrial temperature range: –40°C to +85°C (KSZ8999I)
- Available in 208-pin PQFP package

## Ordering Information

Part Number	Temperature Range	Package
KS8999	0°C to +70°C	208-Pin PQFP
KS8999I	–40°C to +85°C	208-Pin PQFP
KSZ8999	0°C to +70°C	208-Pin PQFP
KSZ8999I	–40°C to +85°C	208-Pin PQFP

## Revision History

Revision	Date	Summary of Changes
1.00	11/27/00	Preliminary Release
1.01	03/30/01	Update maximum frame size Update EEPROM priority descriptions Update I/O pin definition Update I/O descriptions Update Electrical Characteristics
1.02	04/20/01	Correct timing information
1.03	05/11/01	Add MDI/MDI-X description
1.04	06/22/01	Change electrical requirements
1.05	0/6/25/01	Correct I/O descriptions
1.06	07/25/01	Update PLL clock information Update timing information
1.07	08/09/01	Correct LED[6][1:0] to float configuration Add reverse and forward timing Correct optional CPU timing
1.08	1/14/02	Update Optional CPU interface Correct I/O description for MCOL and MCRS Correct pin 174 and 175 description
1.09	6/18/02	Correct default to floating for pin 174 Change pin 87 TEST[3] to AUTOMDIX for enable/disable of auto MDI-MDIX function
1.10	2/27/03	Add KS8999I industrial temperature Update non-periodic blinking in Mode 1 of LED[1:9][0] Add MRXD[0] description
1.11	5/12/03	Changed Vcc from 2.00 to 2.10 (typical) Added FEF disable to T[4] pin #173
1.12	8/29/03	Convert to new format.
1.13	1/19/05	Correct pin type description. Correct selection of reference oscillator/crystal spec. Insert recommended reset circuit.
1.14	1/31/05	Added lead free and Industrial temperature packages.

## Table of Contents

<b>System Level Applications</b> .....	6
<b>Pin Description</b> .....	7
<b>I/O Grouping</b> .....	13
<b>I/O Descriptions</b> .....	13
<b>Pin Configuration</b> .....	19
<b>Functional Overview: Physical Layer Transceiver</b> .....	20
100BaseTX Transmit .....	20
100BaseTX Receive .....	20
PLL Clock Synthesizer .....	20
Scrambler/De-scrambler (100BaseTX only) .....	20
100BaseFX Operation .....	20
100BaseFX Signal Detection .....	20
100BaseFX Far End Fault .....	20
10BaseT Transmit .....	20
10BaseT Receive .....	20
Power Management .....	21
Power Save Mode .....	21
MDI/MDI-X Auto Crossover .....	21
Auto-Negotiation .....	21
<b>Functional Overview: Switch Core</b> .....	22
Address Look-Up .....	22
Learning .....	22
Migration .....	22
Aging .....	22
Forwarding .....	22
Switching Engine .....	22
MAC Operation .....	22
Inter Packet Gap (IPG) .....	22
Backoff Algorithm .....	23
Late Collision .....	23
Illegal Frames .....	23
Flow Control .....	23
Half-Duplex Back Pressure .....	23
Broadcast Storm Protection .....	23
<b>MII Interface Operation</b> .....	24
<b>SNI Interface (7-wire) Operation</b> .....	26
<b>Prorammmable Features</b> .....	26
Priority Schemes .....	26
Per Port Method .....	26
802.1p Method .....	26
IPv4 DSCP Method .....	26
Other Priority Considerations .....	26
<b>VLAN Operation</b> .....	27
<b>Station MAC Address</b> .....	27
<b>EEPROM Operation</b> .....	28
<b>Optional CPU Interface</b> .....	28

<b>EEPROM Memory Map</b> .....	29
General Control Register .....	29
Priority Classification Control: 802.1p Tag Field .....	29
Port 1 Control Register .....	29
Port 2 Control Register .....	30
Port 3 Control Register .....	30
Port 4 Control Register .....	30
Port 5 Control Register .....	31
Port 6 Control Register .....	31
Port 7 Control Register .....	32
Port 8 Control Register .....	32
Port 9 Control Register .....	32
Port 1 VLAN Mask Register .....	33
Port 2 VLAN Mask Register .....	33
Port 3 VLAN Mask Register .....	34
Port 4 VLAN Mask Register .....	34
Port 5 VLAN Mask Register .....	35
Port 6 VLAN Mask Register .....	35
Port 7 VLAN Mask Register .....	36
Port 8 VLAN Mask Register .....	36
Port 9 VLAN Mask Register .....	37
Port 1 VLAN Tag Insertion Value Registers .....	37
Port 2 VLAN Tag Insertion Value Registers .....	37
Port 3 VLAN Tag Insertion Value Registers .....	37
Port 4 VLAN Tag Insertion Value Registers .....	37
Port 5 VLAN Tag Insertion Value Registers .....	38
Port 6 VLAN Tag Insertion Value Registers .....	38
Port 7 VLAN Tag Insertion Value Registers .....	38
Port 8 VLAN Tag Insertion Value Registers .....	38
Port 9 VLAN Tag Insertion Value Registers .....	38
Diff Serve Code Point Registers .....	38
Station MAC Address Registers .....	38
<b>Absolute Maximum Ratings</b> .....	39
<b>Operating Ratings</b> .....	39
<b>Electrical Characteristics (KS8999)</b> .....	39
<b>Electrical Characteristics (KS8999I)</b> .....	41
<b>Timing Diagrams</b> .....	42
<b>Reference Circuit</b> .....	47
<b>4B/5B Coding</b> .....	49
<b>MLT Coding</b> .....	50
<b>MAC Frame</b> .....	50
<b>Selection of Isolation Transformers</b> .....	51
<b>Selection of Reference Oscillator/Crystal</b> .....	51
<b>Qualified Magnetic Lists</b> .....	51
<b>Package Information</b> .....	52

### System Level Applications

The KS8999 can be configured to fit either in an eight port 10/100 application or as a nine port 10/100 network interface with an extra MII/7-wire port. This MII/7-wire port can be connected to an external processor and used for routing

purposes or public network access. The major benefits of using the KS8999 are the lower power consumption, unmanaged operation, flexible configuration, built in frame buffering, VLAN abilities and traffic priority control. Two such applications are depicted below.

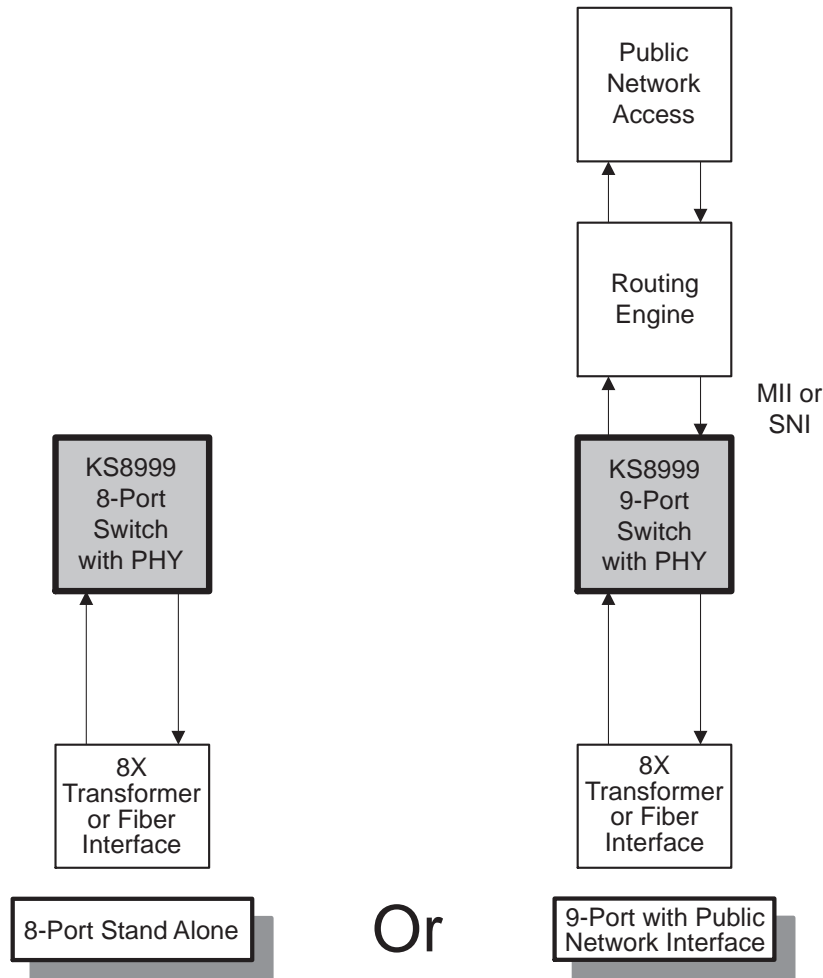


Figure 1. System Applications

## Pin Description

Pin Number	Pin Name	Type <sup>(Note 1)</sup>	Port	Pin Function
1	VDD_RX	Pwr		2.0V for equalizer
2	GND_RX	GND		Ground for equalizer
3	GND_RX	GND		Ground for equalizer
4	VDD_RX	Pwr		2.0V for equalizer
5	RXP[3]	I	3	Physical receive signal + (differential)
6	RXM[3]	I	3	Physical receive signal - (differential)
7	AOUT2	O		Factory test output
8	DOOUT2	O		Factory test output
9	TXP[3]	O	3	Physical transmit signal + (differential)
10	TXM[3]	O	3	Physical transmit signal - (differential)
11	QH[5]	Opd		Factory test pin – leave open for normal operation
12	QH[4]	Opd		Factory test pin – leave open for normal operation
13	QH[3]	Opd		Factory test pin – leave open for normal operation
14	QH[2]	Opd		Factory test pin – leave open for normal operation
15	GND_TX	GND		Ground for transmit circuitry
16	VDD_TX	Pwr		2.0V for transmit circuitry
17	VDD_TX	Pwr		2.0V for transmit circuitry
18	GND-ISO	GND		Analog ground
19	TXP[4]	O	4	Physical transmit signal + (differential)
20	TXM[4]	O	4	Physical transmit signal - (differential)
21	GND_TX	GND		Ground for transmit circuitry
22	RXP[4]	I	4	Physical receive signal + (differential)
23	RXM[4]	I	4	Physical receive signal - (differential)
24	GND_RX	GND		Ground for equalizer
25	VDD_RX	Pwr		2.0V for equalizer
26	ISET			Set physical transmit output current
27	GND-ISO	GND		Analog ground
28	VDD_RX	Pwr		2.0V for equalizer
29	GND_RX	GND		Ground for equalizer
30	RXP[5]	I	5	Physical receive signal + (differential)
31	RXM[5]	I	5	Physical receive signal - (differential)
32	GND_TX	GND		Ground for transmit circuitry
33	TXP[5]	O	5	Physical transmit signal + (differential)
34	TXM[5]	O	5	Physical transmit signal - (differential)

**Note 1.** Pwr = power supply  
 GND = ground  
 I = input  
 O = output  
 I/O = bi-directional  
 Ipu = input w/ internal pull-up  
 Ipd = input w/ internal pull-down  
 Opu = output w/ internal pull-up  
 Opd = output w/ internal pull-down  
 Ipd/O = input w/ internal pull-down during reset, output pin otherwise  
 Ipu/O = input w/ internal pull-up during reset, output pin otherwise

Pin Number	Pin Name	Type <sup>(Note 1)</sup>	Port	Pin Function
35	GND-ISO	GND		Analog ground
36	VDD_TX	Pwr		2.0V for transmit circuitry
37	VDD_TX	Pwr		2.0V for transmit circuitry
38	GND_TX	GND		Ground for transmit circuitry
39	QL[2]	Opd		Factory test pin – leave open for normal operation
40	QL[3]	Opd		Factory test pin – leave open for normal operation
41	QL[4]	Opd		Factory test pin – leave open for normal operation
42	QL[5]	Opd		Factory test pin – leave open for normal operation
43	TXP[6]	O	6	Physical transmit signal + (differential)
44	TXM[6]	O	6	Physical transmit signal - (differential)
45	DOOUT	O		Factory test output – leave open for normal operation
46	AOUT	O		Factory test output – leave open for normal operation
47	RXP[6]	I	6	Physical receive signal + (differential)
48	RXM[6]	I	6	Physical receive signal - (differential)
49	VDD_RX	Pwr		2.0V for equalizer
50	GND_RX	GND		Ground for equalizer
51	GND_RX	GND		Ground for equalizer
52	VDD_RX	Pwr		2.0V for equalizer
53	GND-ISO	GND		Analog ground
54	RXP[7]	I	7	Physical receive signal + (differential)
55	RXM[7]	I	7	Physical receive signal - (differential)
56	GND_TX	GND		Ground for transmit circuitry
57	TXP[7]	O	7	Physical transmit signal + (differential)
58	TXM[7]	O	7	Physical transmit signal - (differential)
59	VDD_TX	Pwr		2.0V for transmit circuitry
60	VDD_TX	Pwr		2.0V for transmit circuitry
61	TXP[8]	O	8	Physical transmit signal + (differential)
62	TXM[8]	O	8	Physical transmit signal - (differential)
63	GND_TX	GND		Ground for transmit circuitry
64	RXP[8]	I	8	Physical receive signal + (differential)
65	RXM[8]	I	8	Physical receive signal - (differential)
66	GND_RX	GND		Ground for equalizer
67	VDD_RX	Pwr		2.0V for equalizer
68	FXSD[5]	lpd	5	Fiber signal detect
69	FXSD[6]	lpd	6	Fiber signal detect

**Note 1.** Pwr = power supply  
GND = ground  
I = input  
O = output  
I/O = bi-directional  
Ipu = input w/ internal pull-up  
Ipd = input w/ internal pull-down  
Opu = output w/ internal pull-up  
Opd = output w/ internal pull-down  
Ipd/O = input w/ internal pull-down during reset, output pin otherwise  
Ipu/O = input w/ internal pull-up during reset, output pin otherwise



Pin Number	Pin Name	Type <sup>(Note 1)</sup>	Port	Pin Function
70	FXSD[7]	lpd	7	Fiber signal detect
71	FXSD[8]	lpd	8	Fiber signal detect
72	GND_RCV	GND		Ground for clock recovery circuit
73	GND_RCV	GND		Ground for clock recovery circuit
74	VDD_RCV	Pwr		2.0V for clock recovery circuit
75	VDD_RCV	Pwr		2.0V for clock recovery circuit
76	GND_RCV	GND		Ground for clock recovery circuit
77	GND_RCV	GND		Ground for clock recovery circuit
78	VDD_RCV	Pwr		2.0V for clock recovery circuit
79	VDD_RCV	Pwr		2.0V for clock recovery circuit
80	BTOUT2	O		Factory test pin – leave open for normal operation
81	CTOUT2	O		Factory test pin – leave open for normal operation
82	RLPBK	I		Enable loop back for testing – pull-down/float for normal operation
83	MUX[1]	I		Factory test pin – float for normal operation
84	MUX[2]	I		Factory test pin – float for normal operation
85	TEST[1]	I		Factory test pin – float for normal operation
86	TEST[2]	I		Factory test pin – float for normal operation
87	AUTOMDIX	I		Auto MDI/MDIX enable and disable – pull-up/float enable; pull-down disable
88	T[1]	lpu		Factory test pin – float for normal operation
89	T[2]	lpd		Factory test pin – float for normal operation
90	T[3]	lpd		Factory test pin – float for normal operation
91	EN1P	lpd		Enable 802.1p for all ports
92	SDA	lpd/O		Serial data from EEPROM or processor
93	SCL	lpd/O		Clock for EEPROM or from processor
94	VDD	Pwr		2.0V for core digital circuitry
95	GND	GND		Ground for digital circuitry
96	MTXEN	lpd	9	MII transmit enable
97	MTXD[3]	lpd	9	MII transmit bit 3
98	MTXD[2]	lpd	9	MII transmit bit 2
99	MTXD[1]	lpd	9	MII transmit bit 1
100	MTXD[0]	lpd	9	MII transmit bit 0
101	MTXER	lpd	9	MII transmit error
102	MTXC	lpd/O	9	MII transmit clock
103	MCOL	lpd/O	9	MII collision detected
104	MCRS	lpd/O	9	MII carrier sense

**Note 1.** Pwr = power supply  
GND = ground  
I = input  
O = output  
I/O = bi-directional  
lpu = input w/ internal pull-up  
lpd = input w/ internal pull-down  
Opu = output w/ internal pull-up  
Opd = output w/ internal pull-down  
lpd/O = input w/ internal pull-down during reset, output pin otherwise  
lpu/O = input w/ internal pull-up during reset, output pin otherwise

Pin Number	Pin Name	Type <sup>(Note 1)</sup>	Port	Pin Function
105	VDD-IO	Pwr		2.0V, 2.5V or 3.3V for I/O circuitry
106	GND	GND		Ground for digital circuitry
107	GND	GND		Ground for digital circuitry
108	VDD	Pwr		2.0V for core digital circuitry
109	BIST	lpd		Built in self test – tie low for normal operation
110	RST#	I		Reset – active low
111	LED[1][3]	lpu/O	1	LED indicator 3
112	LED[1][2]	lpu/O	1	LED indicator 2
113	LED[1][1]	lpu/O	1	LED indicator 1
114	LED[1][0]	lpu/O	1	LED indicator 0
115	LED[2][3]	lpu/O	2	LED indicator 3
116	LED[2][2]	lpu/O	2	LED indicator 2
117	LED[2][1]	lpu/O	2	LED indicator 1
118	LED[2][0]	lpu/O	2	LED indicator 0
119	MRXDV	Opd	9	MII receive data valid
120	MRXD[3]	Opu	9	MII receive bit 3
121	MRXD[2]	Opu	9	MII receive bit 2
122	MRXD[1]	Opu	9	MII receive bit 1
123	MRXD[0]	Opu	9	MII receive bit 0
124	MRXC	lpu/O	9	MII receive clock
125	VDD-IO	Pwr		2.0V, 2.5V or 3.3V for I/O circuitry
126	GND	GND		Ground for digital circuitry
127	LED[3][3]	lpu/O	3	LED indicator 3
128	LED[3][2]	lpu/O	3	LED indicator 2
129	LED[3][1]	lpu/O	3	LED indicator 1
130	LED[3][0]	lpu/O	3	LED indicator 0
131	LED[4][3]	lpu/O	4	LED indicator 3
132	LED[4][2]	lpu/O	4	LED indicator 2
133	LED[4][1]	lpu/O	4	LED indicator 1
134	LED[4][0]	lpu/O	4	LED indicator 0
135	VDD	Pwr		2.0V for core digital circuitry
136	GND	GND		Ground for digital circuitry
137	LED[5][3]	lpu/O	5	LED indicator 3
138	LED[5][2]	lpu/O	5	LED indicator 2
139	LED[5][1]	lpu/O	5	LED indicator 1

**Note 1.** Pwr = power supply  
 GND = ground  
 I = input  
 O = output  
 I/O = bi-directional  
 lpu = input w/ internal pull-up  
 lpd = input w/ internal pull-down  
 Opu = output w/ internal pull-up  
 Opd = output w/ internal pull-down  
 lpd/O = input w/ internal pull-down during reset, output pin otherwise  
 lpu/O = input w/ internal pull-up during reset, output pin otherwise

Pin Number	Pin Name	Type <sup>(Note 1)</sup>	Port	Pin Function
140	LED[5][0]	lpu/O	5	LED indicator 0
141	LED[6][3]	lpu/O	6	LED indicator 3
142	LED[6][2]	lpu/O	6	LED indicator 2
143	LED[6][1]	lpu/O	6	LED indicator 1
144	LED[6][0]	lpu/O	6	LED indicator 0
145	LED[7][3]	lpu/O	7	LED indicator 3
146	LED[7][2]	lpu/O	7	LED indicator 2
147	LED[7][1]	lpu/O	7	LED indicator 1
148	VDD-IO	Pwr		2.0V, 2.5V or 3.3V for I/O circuitry
149	LED[7][0]	lpu/O	7	LED indicator 0
150	LED[8][3]	lpu/O	8	LED indicator 3
151	LED[8][2]	lpu/O	8	LED indicator 2
152	LED[8][1]	lpu/O	8	LED indicator 1
153	LED[8][0]	lpu/O	8	LED indicator 0
154	GND	GND		Ground for digital circuitry
155	GND	GND		Ground for digital circuitry
156	IO_SWM	lpu		Factory test pin – tie high for normal operation
157	VDD	Pwr		2.0V for core digital circuitry
158	LED[9][3]	lpu/O	9	LED indicator 3
159	LED[9][2]	lpu/O	9	LED indicator 2
160	LED[9][1]	lpu/O	9	LED indicator 1
161	LED[9][0]	lpu/O	9	LED indicator 0
162	MIIS[1]	lpd	9	MII mode select bit 1
163	MIIS[0]	lpd	9	MII mode select bit 0
164	MODESEL[3]	lpd		Selects LED and test modes
165	MODESEL[2]	lpd		Selects LED and test modes
166	MODESEL[1]	lpd		Selects LED and test modes
167	MODESEL[0]	lpd		Selects LED and test modes
168	TESTEN	lpd		Factory test pin – tie low for normal operation
169	SCANEN	lpd		Factory test pin – tie low for normal operation
170	PRSV	lpd		Reserve 6KB buffer for priority frames
171	CFGMODE	lpu		Configures programming interface for EEPROM or processor
172	T[5]	I		Factory test pin – float for normal operation
173	T[4]	lpdthevillage		F/D = normal operation (default) U = disable FEF
174	Reserve	I		Reserved – floating for normal operation

**Note 1.** Pwr = power supply  
GND = ground  
I = input  
O = output  
I/O = bi-directional  
lpu = input w/ internal pull-up  
lpd = input w/ internal pull-down  
Opu = output w/ internal pull-up  
Opd = output w/ internal pull-down  
lpd/O = input w/ internal pull-down during reset, output pin otherwise  
lpu/O = input w/ internal pull-up during reset, output pin otherwise

Pin Number	Pin Name	Type <sup>(Note 1)</sup>	Port	Pin Function
175	Reserve	I		Reserved - floating for normal operation
176	X1	I		Crystal or clock input
177	X2	O		Connect to crystal
178	VDD_PLLTX	Pwr		2.0 V for phase locked loop circuit
179	GND_PLLTX	GND		Ground for phase locked loop circuit
180	CTOUT	O		Factory test pin – leave open for normal operation
181	BTOUT	O		Factory test pin – leave open for normal operation
182	VDD_RCV	Pwr		2.0V for clock recovery circuit
183	VDD_RCV	Pwr		2.0V for clock recovery circuit
184	GND_RCV	GND		Ground for clock recovery circuit
185	GND_RCV	GND		Ground for clock recovery circuit
186	VDD_RCV	Pwr		2.0V for clock recovery circuit
187	VDD_RCV	Pwr		2.0V for clock recovery circuit
188	GND_RCV	GND		Ground for clock recovery circuit
189	GND_RCV	GND		Ground for clock recovery circuit
190	FXSD[1]	Ipd	1	Fiber signal detect
191	FXSD[2]	Ipd	2	Fiber signal detect
192	FXSD[3]	Ipd	3	Fiber signal detect
193	FXSD[4]	Ipd	4	Fiber signal detect
194	VDD_RX	Pwr		2.0V for equalizer
195	GND_RX	GND		Ground for equalizer
196	RXP[1]	I	1	Physical receive signal + (differential)
197	RXM[1]	I	1	Physical receive signal - (differential)
198	GND_TX	GND		Ground for transmit circuitry
199	TXP[1]	O	1	Physical transmit signal + (differential)
200	TXM[1]	O	1	Physical transmit signal - (differential)
201	VDD_TX	Pwr		2.0V for transmit circuitry
202	VDD_TX	Pwr		2.0V for transmit circuitry
203	TXP[2]	O	2	Physical transmit signal + (differential)
204	TXM[2]	O	2	Physical transmit signal - (differential)
205	GND_TX	GND		Ground for transmit circuitry
206	RXP[2]	I	2	Physical receive signal + (differential)
207	RXM[2]	I	2	Physical receive signal - (differential)
208	GND-ISO	GND		Analog ground

**Note 1.** Pwr = power supply  
GND = ground  
I = input  
O = output  
I/O = bi-directional  
Ipu = input w/ internal pull-up  
Ipd = input w/ internal pull-down  
Opu = output w/ internal pull-up  
Opd = output w/ internal pull-down  
Ipd/O = input w/ internal pull-down during reset, output pin otherwise  
Ipu/O = input w/ internal pull-up during reset, output pin otherwise

## I/O Grouping

Group Name	Description
PHY	Physical Interface
MII	Media Independent Interface
SNI	Serial Network Interface
IND	LED Indicators
UP	Unmanaged Programmable
CTRL	Control and Miscellaneous
TEST	Test (Factory)
PWR	Power and Ground

## I/O Descriptions

Group	I/O Names	Active Status	Description
PHY	RXP[1:8] RXM[1:8]	Analog	Differential inputs (receive) for connection to media (transformer or fiber module)
	TXP[1:8] TXM[1:8]	Analog	Differential outputs (transmit) for connection to media (transformer or fiber module)
	FXSD[1:8]	H	Fiber signal detect – connect to fiber signal detect output on fiber module with appropriate voltage divider if needed. Tie low for copper mode.
	ISSET	Analog	Transmit Current Set. Connecting an external reference resistor to set transmitter output current. This pin connects to a 3K $\Omega$ 1% resistor to ground if a transformer with 1:1 turn ratio is used.
MII	MRXD[0:3]	H	Four bit wide data bus for receiving MAC frames
	MRXDV	H	Receive data valid
	MCOL	H	Receive collision detection
	MCRS	H	Carrier sense
	MTXD[0:3]	H	Four bit wide data bus for transmitting MAC frames
	MTXEN	H	Transmit enable
	MTXER	H	Transmit error
	MRXC	Clock	MII receive clock
	MTXC	Clock	MII transmit clock
SNI	MTXD[0]	H	Serial transmit data
	MTXEN	H	Transmit enable
	MRXD[0]	H	Serial receive data
	MRXDV	H	Receive carrier sense/data valid
	MCOL	H	Collision detection
	MRXC	Clock	SNI receive clock
	MTXC	Clock	SNI transmit clock
IND	LED[1:9][0]	L	Output (after reset) Mode 0: Speed (on = 100/off = 10) Mode 1: 10/100 + link + activity 10Mb link activity = slow blink (non-periodic blinking) 100Mb link activity = fast blink (non-periodic blinking) Mode 2: Collision (on = collision/off = no collision) Mode 3: Speed (on = 100/off = 10)

Group	I/O Names	Active Status	Description(Notes 1)																																																																																										
	LED[1:9][1]	L	Output (after reset) Mode 0: Full Duplex (on = full/off = half) Mode 1: Full Duplex (on = full/off = half) Mode 2: Full Duplex (on = full/off = half) Mode 3: Reserved																																																																																										
	LED[1:9][2]	L	Output (after reset) Mode 0: Collision (on = collision/off = no collision) Mode 1: Transmit Activity (on during transmission) Mode 2: Link activity (10Mb mode) Mode 3: Full Duplex + Collision (constant on = full duplex; intermittent on = collision; off = half-duplex with no collision)																																																																																										
	LED[1:9][3]	L	Output (after reset) Mode 0: Link + Activity When LED is solid "on", it indicates the link is on for both 10 or 100BaseTX, but no data is transmitting or receiving. When LED is solid "off", it indicates the link is off. When LED is blinking, it indicates data is transmitting or receiving for either 10 or 100 BaseTX Mode 1: Receive Activity (on = receiving/off = not receiving) Mode 2: Link activity (100Mb mode) Mode 3: Link + Activity (see description above) <i>Note: Mode is set by MODESEL[3:0]; please see description in UP (unmanaged programming) section.</i>																																																																																										
UP	MODESEL[3:0]	H	Mode select at reset time. LED mode is selected by using the table below. Note that under normal operation MODESEL[3:2] must be tied low. <table border="1" style="width: 100%; border-collapse: collapse;"> <thead> <tr> <th colspan="4">MODESEL</th> <th></th> </tr> <tr> <th>3</th> <th>2</th> <th>1</th> <th>0</th> <th>Operation</th> </tr> </thead> <tbody> <tr> <td>0</td> <td>0</td> <td>0</td> <td>0</td> <td>LED mode 0</td> </tr> <tr> <td>0</td> <td>0</td> <td>0</td> <td>1</td> <td>LED mode 1</td> </tr> <tr> <td>0</td> <td>0</td> <td>1</td> <td>0</td> <td>LED mode 2</td> </tr> <tr> <td>0</td> <td>0</td> <td>1</td> <td>1</td> <td>LED mode 3</td> </tr> <tr> <td>0</td> <td>1</td> <td>0</td> <td>0</td> <td>Used for factory testing</td> </tr> <tr> <td>0</td> <td>1</td> <td>0</td> <td>1</td> <td>Used for factory testing</td> </tr> <tr> <td>0</td> <td>1</td> <td>1</td> <td>0</td> <td>Used for factory testing</td> </tr> <tr> <td>0</td> <td>1</td> <td>1</td> <td>1</td> <td>Used for factory testing</td> </tr> <tr> <td>1</td> <td>0</td> <td>0</td> <td>0</td> <td>Used for factory testing</td> </tr> <tr> <td>1</td> <td>0</td> <td>0</td> <td>1</td> <td>Used for factory testing</td> </tr> <tr> <td>1</td> <td>0</td> <td>1</td> <td>0</td> <td>Used for factory testing</td> </tr> <tr> <td>1</td> <td>0</td> <td>1</td> <td>1</td> <td>Used for factory testing</td> </tr> <tr> <td>1</td> <td>1</td> <td>0</td> <td>0</td> <td>Used for factory testing</td> </tr> <tr> <td>1</td> <td>1</td> <td>0</td> <td>1</td> <td>Used for factory testing</td> </tr> <tr> <td>1</td> <td>1</td> <td>1</td> <td>0</td> <td>Used for factory testing</td> </tr> <tr> <td>1</td> <td>1</td> <td>1</td> <td>1</td> <td>Used for factory testing</td> </tr> </tbody> </table>	MODESEL					3	2	1	0	Operation	0	0	0	0	LED mode 0	0	0	0	1	LED mode 1	0	0	1	0	LED mode 2	0	0	1	1	LED mode 3	0	1	0	0	Used for factory testing	0	1	0	1	Used for factory testing	0	1	1	0	Used for factory testing	0	1	1	1	Used for factory testing	1	0	0	0	Used for factory testing	1	0	0	1	Used for factory testing	1	0	1	0	Used for factory testing	1	0	1	1	Used for factory testing	1	1	0	0	Used for factory testing	1	1	0	1	Used for factory testing	1	1	1	0	Used for factory testing	1	1	1	1	Used for factory testing
MODESEL																																																																																													
3	2	1	0	Operation																																																																																									
0	0	0	0	LED mode 0																																																																																									
0	0	0	1	LED mode 1																																																																																									
0	0	1	0	LED mode 2																																																																																									
0	0	1	1	LED mode 3																																																																																									
0	1	0	0	Used for factory testing																																																																																									
0	1	0	1	Used for factory testing																																																																																									
0	1	1	0	Used for factory testing																																																																																									
0	1	1	1	Used for factory testing																																																																																									
1	0	0	0	Used for factory testing																																																																																									
1	0	0	1	Used for factory testing																																																																																									
1	0	1	0	Used for factory testing																																																																																									
1	0	1	1	Used for factory testing																																																																																									
1	1	0	0	Used for factory testing																																																																																									
1	1	0	1	Used for factory testing																																																																																									
1	1	1	0	Used for factory testing																																																																																									
1	1	1	1	Used for factory testing																																																																																									
	LED[1][3]		Programs auto-negotiation on port 1 D = Disable auto-negotiation, F/U = Enable auto-negotiation (default)																																																																																										
	LED[1][2]		Programs auto-negotiation on port 2 D = Disable auto-negotiation, F/U = Enable auto-negotiation (default)																																																																																										
	LED[1][1]		Programs auto-negotiation on port 3 D = Disable auto-negotiation, F/U = Enable auto-negotiation (default)																																																																																										

**Note 1.** All unmanaged programming takes place at reset time only. For unmanaged programming: F = Float, D = Pull-down, U = Pull-up. See "Reference Circuits" section.

Group	I/O Names	Active Status	Description <sup>(Note 1)</sup>
	LED[1][0]		Programs auto-negotiation on port 4 D = Disable auto-negotiation, F/U = Enable auto-negotiation (default)
	LED[2][3]		Programs auto-negotiation on port 5 D = Disable auto-negotiation, F/U = Enable auto-negotiation (default)
	LED[2][2]		Programs auto-negotiation on port 6 D = Disable auto-negotiation, F/U = Enable auto-negotiation (default)
	LED[2][1]		Programs auto-negotiation on port 7 D = Disable auto-negotiation, F/U = Enable auto-negotiation (default)
	LED[2][0]		Programs auto-negotiation on port 8 D = Disable auto-negotiation, F/U = Enable auto-negotiation (default)
	LED[3][3]		Programs port speed on port 1. This is only effective if auto-negotiation is disabled. D = 10Mbps, F/U = 100Mbps (default)
	LED[3][2]		Programs port speed on port 2. This is only effective if auto-negotiation is disabled. D = 10Mbps, F/U = 100Mbps (default)
	LED[3][1]		Programs port speed on port 3. This is only effective if auto-negotiation is disabled. D = 10Mbps, F/U = 100Mbps (default)
	LED[3][0]		Programs port speed on port 4. This is only effective if auto-negotiation is disabled. D = 10Mbps, F/U = 100Mbps (default)
	LED[4][3]		Programs port speed on port 5. This is only effective if auto-negotiation is disabled. D = 10Mbps, F/U = 100Mbps (default)
	LED[4][2]		Programs port speed on port 6. This is only effective if auto-negotiation is disabled. D = 10Mbps, F/U = 100Mbps (default)
	LED[4][1]		Programs port speed on port 7. This is only effective if auto-negotiation is disabled. D = 10Mbps, F/U = 100Mbps (default)
	LED[4][0]		Programs port speed on port 8. This is only effective if auto-negotiation is disabled. D = 10Mbps, F/U = 100Mbps (default)
	LED[5][3]		Programs port duplex (full/ half) on port 1. This is only effective if auto-negotiation is disabled or if this end has auto-negotiation enabled and the far end has auto negotiation disabled. D = Full-duplex, F/U = Half-duplex (default)
	LED[5][2]		Programs port duplex (full/ half) on port 2. This is only effective if auto-negotiation is disabled or if this end has auto-negotiation enabled and the far end has auto-negotiation disabled. D = Full-duplex, F/U = Half-duplex (default)
	LED[5][1]		Programs port duplex (full/ half) on port 3. This is only effective if auto-negotiation is disabled or if this end has auto-negotiation enabled and the far end has auto-negotiation disabled. D = Full-duplex, F/U = Half-duplex (default)
	LED[5][0]		Programs port duplex (full/ half) on port 4. This is only effective if auto-negotiation is disabled or if this end has auto-negotiation enabled and the far end has auto-negotiation disabled. D = Full-duplex, F/U = Half-duplex (default)
	LED[9][3]		Programs port duplex (full/ half) on port 5. This is only effective if auto-negotiation is disabled or if this end has auto-negotiation enabled and the far end has auto negotiation disabled. D = Full-duplex, F/U = Half-duplex (default)
	LED[9][2]		Programs port duplex (full/ half) on port 6. This is only effective if auto-negotiation is disabled or if this end has auto-negotiation enabled and the far end has auto-negotiation disabled. D = Full-duplex, F/U = Half-duplex (default)

**Note 1.** All unmanaged programming takes place at reset time only. For unmanaged programming: F = Float, D = Pull-down, U = Pull-up. See "Reference Circuits" section.

Group	I/O Names	Active Status	Description(Notes 1)												
	LED[9][1]		Programs port duplex (full / half) on port 7. This is only effective if auto-negotiation is disabled or if this end has auto-negotiation enabled and the far end has auto-negotiation disabled. D = Full-duplex, F/U = Half-duplex (default)												
	LED[9][0]		Programs port duplex (full / half) on port 8. This is only effective if auto-negotiation is disabled or if this end has auto-negotiation enabled and the far end has auto-negotiation disabled. D = Full-duplex, F/U = Half-duplex (default)												
	LED[6][3]		Programs back-off aggressiveness for half-duplex mode D = Less aggressive back-off, F/U = More aggressive back-off (default)												
	LED[6][2]		Programs retries for frames that encounter collisions. D = Drop frame after 16 collisions, F/U = Continue sending frame regardless of the number of collisions (default)												
	LED[6][1:0]		Reserved – use float configuration												
	LED[7][3]		Programs flow control D = No flow control, F/U = Flow control enabled (default)												
	LED[7][2]		Programs broadcast storm protection. D = 5% broadcast frames allowed, F/U = Unlimited broadcast frames (default)												
	LED[7][1]		Programs buffer sharing feature. D = Equal amount of buffers per port (113 buffers), F/U = Share buffers up to 512 buffers on a single port (default)												
	LED[7][0]		Reserved – use float configuration												
	LED[8][3]		Programs address aging. D = Aging disabled, F/U = Enable 5 minute aging (default)												
	LED[8][2]		Programs frame length enforcement. D = Max length for VLAN is 1522 bytes and without VLAN is 1518 bytes F/U = Max length is 1536 bytes (default)												
	LED[8][1]		Reserved												
	LED[8][0]		Programs half-duplex back pressure. D = No half-duplex back pressure, F/U = Half-duplex back pressure enabled (default)												
	MRXD[3]		Programs port 9 speed D = 10Mbps, F/U = 100Mbps (default)												
	MRXD[2]		Programs port 9 duplex D = Half-duplex, F/U = Full duplex (default)												
	MRXD[1]		Programs port 9 flow control D = Flow control, F/U = No flow control (default)												
	MRXD[0]		D = reserved, F/U = normal operation (default)												
CTRL	EN1P	H	Enable 802.1p for all ports – this enables QoS based on the priority field in the layer 2 header.												
			0 = 802.1p selected by port in EEPROM 1 = Use 802.1p priority field unless disabled in EEPROM <i>Note: This is also controlled by the EEPROM registers (registers 4-12 bit 4). The values in the EEPROM supercede this pin. Also, if the priority selection is unaltered in the EEPROM registers (register 3 bits 0-7) then values above 3 are considered high priority and less than 4 are low priority.</i>												
	MIIS[1:0]	H	MII mode selection – allows the MII to run in the following modes <table border="1" style="margin-left: 20px;"> <thead> <tr> <th>MIIS</th> <th>Operating mode</th> </tr> </thead> <tbody> <tr> <td>1 0</td> <td></td> </tr> <tr> <td>0 0</td> <td>Disable MII interface</td> </tr> <tr> <td>0 1</td> <td>Reverse MII</td> </tr> <tr> <td>1 0</td> <td>Forward MII</td> </tr> <tr> <td>1 1</td> <td>7 wire mode (SNI)</td> </tr> </tbody> </table>	MIIS	Operating mode	1 0		0 0	Disable MII interface	0 1	Reverse MII	1 0	Forward MII	1 1	7 wire mode (SNI)
MIIS	Operating mode														
1 0															
0 0	Disable MII interface														
0 1	Reverse MII														
1 0	Forward MII														
1 1	7 wire mode (SNI)														

**Note 1.** All unmanaged programming takes place at reset time only. For unmanaged programming: F = Float, D = Pull-down, U = Pull-up.  
See "Reference Circuits" section.

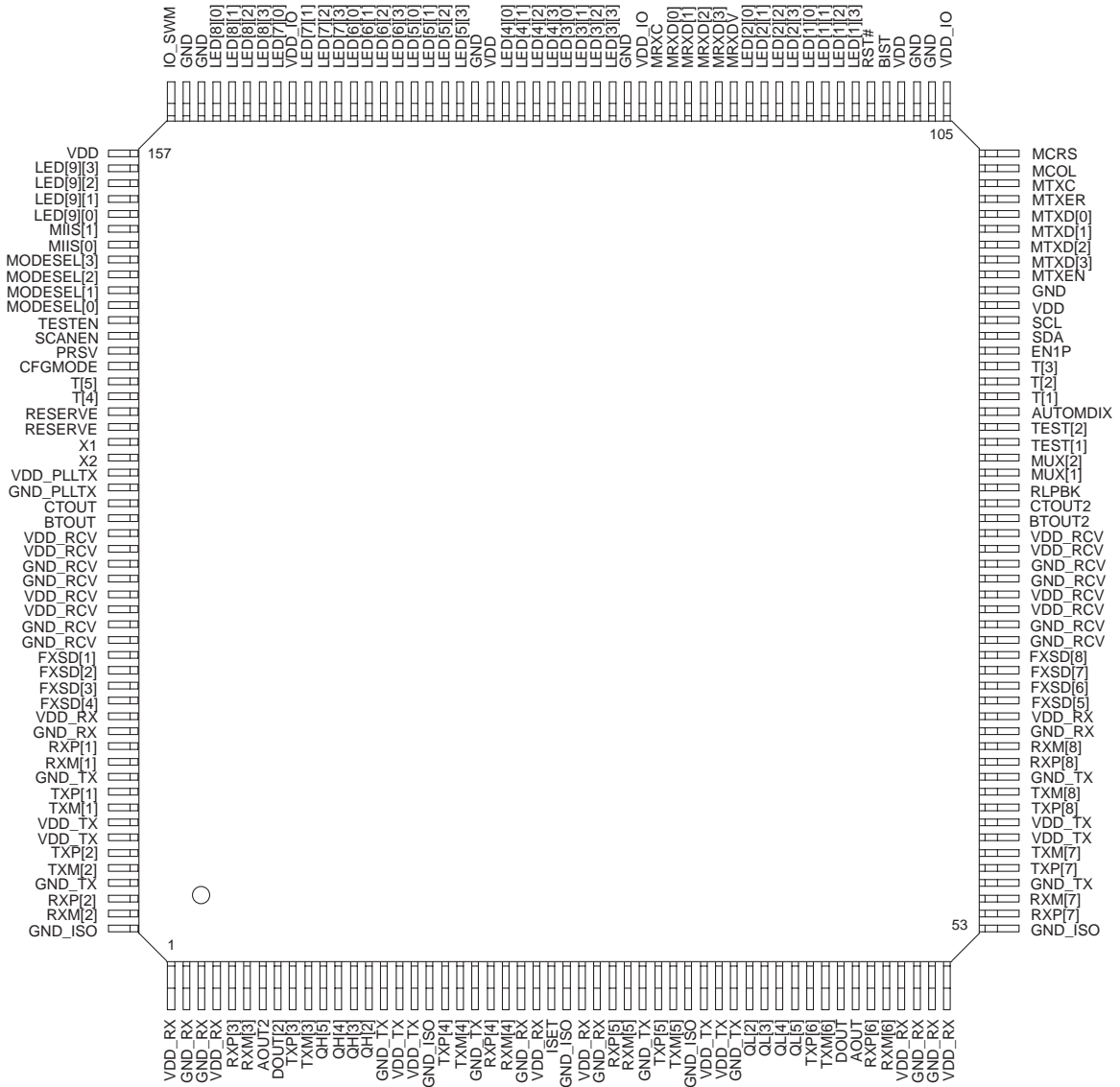


Group	I/O Names	Active Status	Description <sup>(Note 1)</sup>
	PRSV	H	Priority buffer reserve – reserves 6KB of buffer space for the priority traffic if enabled. 0 = No priority reserve 1 = Reserve 6KB for priority traffic <i>Note: This is also controlled by the EEPROM registers (register 2 bit 1). The value in the EEPROM supercedes this pin.</i>
	CFGMODE	H	Selects between EEPROM or processor for programming interface. 0 = Processor interface 1 = EEPROM interface or not programmed on this interface (SCL / SDA not used)
	X1	Clock	External crystal or clock input
	X2	Clock	Used when other polarity of crystal is needed. This is unused for a normal clock input.
	SCL	Clock	Clock for EEPROM
	SDA	I/O	Serial data for EEPROM
	RST#	L	System reset
TEST	TESTEN	H	Factory test input – tie low for normal operation
	SCANEN	H	Factory test input – tie low for normal operation
	MUX[1:2]	H	Factory test input – leave open for normal operation
	AOUT	H	Factory test output – leave open for normal operation
	DOUT	H	Factory test output – leave open for normal operation
	AOUT2	H	Factory test output – leave open for normal operation
	DOUT2	H	Factory test output – leave open for normal operation
	BTOUT	H	Factory test output – leave open for normal operation
	CTOUT	H	Factory test output – leave open for normal operation
	BTOUT2	H	Factory test output – leave open for normal operation
	CTOUT2	H	Factory test output – leave open for normal operation
	TEST[1:2]	H	Factory test inputs – leave open for normal operation
	AUTOMDIX	H	F/U = Enable Auto MDI/MDIX (normal operation) D = Disable Auto MDI/MDIX
	T[1:3] & T[5]	H	Factory test inputs – leave open (float) for normal operation
	T[4]	H	F/D = normal operation (default) U = Disable FEF
	QH[2:5]	H	Factory test outputs – leave open for normal operation
	QL[2:5]	H	Factory test outputs – leave open for normal operation
	IO_SWM	H	Factory test input – tie high for normal operation
	RLPBK	H	Factory test input – tie low for normal operation
	BIST	H	Factory test input – tie low for normal operation
PWR	VDD_RX		2.0V for equalizer
	GND_RX		Ground for equalizer
	VDD_TX		2.0V for transmit circuitry
	GND_TX		Ground for transmit circuitry
	VDD_RCV		2.0V for clock recovery circuitry
	GND_RCV		Ground for clock recovery
	VDD_PLLTX		2.0V for phase locked loop circuitry

**Note 1.** All unmanaged programming takes place at reset time only. For unmanaged programming: F = Float, D = Pull-down, U = Pull-up. See "Reference Circuits" section.

Group	I/O Names	Active Status	Description
	GND_PLLTX		Ground for phase locked loop circuitry
	GND-ISO		Analog ground
	VDD		2.0V for core digital circuitry
	VDD-IO		2.0V, 2.5V or 3.3V for I/O circuitry
	GND		Ground for digital circuitry

# Pin Configuration



208-Pin PQFP (PQ)

## Functional Overview: Physical Layer Transceiver

### 100BaseTX Transmit

The 100BaseTX transmit function performs parallel to serial conversion, 4B/5B coding, scrambling, NRZ to NRZI conversion, MLT3 encoding and transmission. The circuit starts with a parallel to serial conversion, which converts the data from the MAC into a 125MHz serial bit stream. The data and control stream is then converted into 4B/5B coding followed by a scrambler. The serialized data is further converted from NRZ to NRZI format, then transmitted in MLT3 current output. The output current is set by an external 1% 3.01k $\Omega$  resistor for the 1:1 transformer ratio. It has a typical rise/fall time of 4 ns and complies to the ANSI TP-PMD standard regarding amplitude balance, overshoot and timing jitters. The wave-shaped 10BaseT output is also incorporated into the 100BaseTX transmitter.

### 100BaseTX Receive

The 100BaseTX receiver function performs adaptive equalization, DC restoration, MLT3 to NRZI conversion, data and clock recovery, NRZI to NRZ conversion, de-scrambling, 4B/5B decoding and serial to parallel conversion. The receiving side starts with the equalization filter to compensate inter-symbol interference (ISI) over the twisted pair cable. Since the amplitude loss and phase distortion is a function of the length of the cable, the equalizer has to adjust its characteristics to optimize the performance. This is an ongoing process and can self adjust to the environmental changes such as temperature variations. The equalized signal then goes through a DC restoration and data conversion block. The DC restoration circuit is used to compensate for the effect of base line wander and improve the dynamic range. The differential data conversion circuit converts the MLT3 format back to NRZI. The slicing threshold is also adaptive. The clock recovery circuit extracts the 125MHz clock from the edges of the NRZI signal. This recovered clock is then used to convert the NRZI signal into the NRZ format. The signal is then sent through the de-scrambler followed by the 4B/5B decoder. Finally, the NRZ serial data is provided as the input data to the MAC.

### PLL Clock Synthesizer

The KS8999 generates 125MHz, 62.5MHz, 25MHz and 10MHz clocks for system timing. Internal clocks are generated from an external 25MHz crystal.

### Scrambler/De-scrambler (100BaseTX only)

The purpose of the scrambler is to spread the power spectrum of the signal in order to reduce EMI and baseline wander. The data is scrambled by the use of an 11-bit wide linear feedback shift register (LFSR). This can generate a 2047-bit non-repetitive sequence. The receiver will then de-scramble the incoming data stream with the same sequence at the transmitter.

### 100BaseFX Operation

100BaseFX operation is very similar to 100BaseTX operation with the differences being that the scrambler/de-scrambler and MLT3 encoder/decoder are bypassed on transmission and reception. In this mode the auto-negotiation feature is bypassed since there is no standard that supports fiber auto-negotiation.

### 100BaseFX Signal Detection

The physical port runs in 100BaseFX mode if FXSDx > 0.6V. FXSDx is considered 'low' when 0.6V < FXSDx < 1.25V and considered 'high' when FXSDx > 1.25V. If FXSDx goes into 'low' state, the link is considered lost and the link active LED will go off. For FXSDx in the high state, the link is considered active. When FXSDx is below .6V then 100BaseFX mode is disabled. (see application note for detailed information).

### 100BaseFX Far End Fault

Far end fault occurs when the signal detection is logically false from the receive fiber module which occurs when FXSDx is below 1.2V and above 0.6V. When this occurs, the transmission side signals the other end of the link by sending 84 1's followed by a zero in the idle period between frames.

### 10BaseT Transmit

The output 10BaseT driver is incorporated into the 100BaseT driver to allow transmission with the same magnetics. They are internally wave-shaped and pre-emphasized into outputs with a typical 2.3V amplitude.

### 10BaseT Receive

On the receive side, input buffer and level detecting squelch circuits are employed. A differential input receiver circuit and a PLL perform the decoding function. The Manchester-encoded data stream is separated into clock signal and NRZ data. A squelch circuit rejects signals with levels less than 400mV or with short pulse widths in order to prevent noises at the RXP or RXM input from falsely triggering the decoder. When the input exceeds the squelch limit, the PLL locks onto the incoming signal and the KS8999 decodes a data frame. The receiver clock is maintained active during idle periods in between data reception.

## Power Management

### Power Save Mode

The KS8999 will turn off everything except for the Energy Detect and PLL circuits when the cable is not installed on an individual port basis. In other words, the KS8999 will shutdown most of the internal circuits to save power if there is no link.

### MDI/MDI-X Auto Crossover

The KS8999 supports MDI/MDI-X auto crossover. This facilitates the use of either a straight connection CAT-5 cable or a crossover CAT-5 cable. The auto-sense function will detect remote transmit and receive pairs, and correctly assign the transmit and receive pairs from the Micrel device. This can be highly useful when end users are unaware of cable types and can also save on an additional uplink configuration connection.

The auto MDI/MDI-X is achieved by the Micrel device listening for the far end transmission channel and assigning transmit/receive pairs accordingly. Auto MDI/MDI-X can be disabled by pulling the pin 87 (AUTOMDIX) to low.

### Auto-Negotiation

The KS8999 conforms to the auto-negotiation protocol as described by the 802.3 committee. Auto-negotiation allows UTP (Unshielded Twisted Pair) link partners to select the best common mode of operation. In auto-negotiation the link partners advertise capabilities across the link to each other. If auto-negotiation is not supported or the link partner to the KS8999 is forced to bypass auto-negotiation, then the mode is set by observing the signal at the receiver. This is known as parallel mode because while the transmitter is sending auto-negotiation advertisements, the receiver is listening for advertisements or a fixed signal protocol.

The flow for the link set up is depicted below.

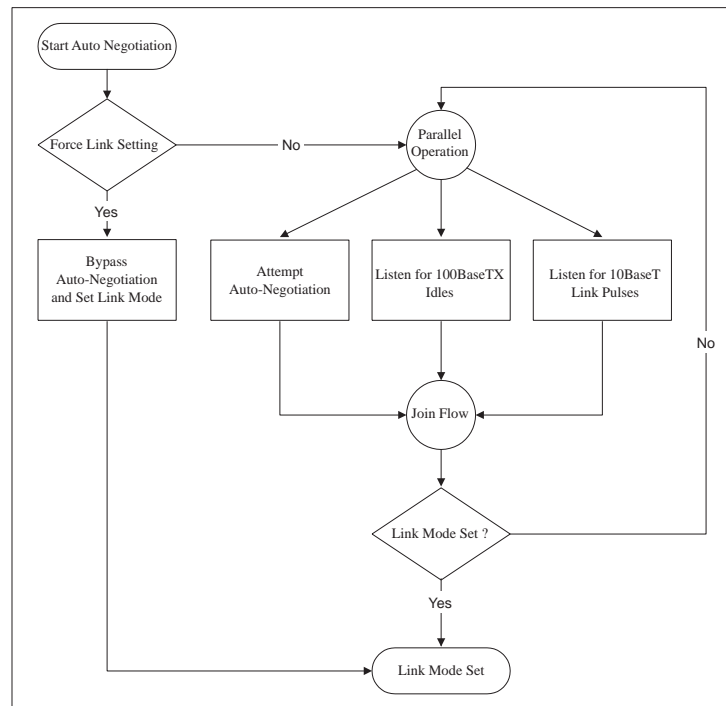


Figure 2. Auto-Negotiation

## Functional Overview: Switch Core

### Address Look-Up

The internal look-up table stores MAC addresses and their associated information. It contains 1K full CAM with 48-bit address plus switching information. The KS8999 is guaranteed to learn 1K addresses and distinguishes itself from hash-based look-up tables which, depending on the operating environment and probabilities, may not guarantee the absolute number of addresses it can learn.

### Learning

The internal look-up engine will update its table with a new entry if the following conditions are met:

- The received packet's SA does not exist in the look-up table.
- The received packet is good; the packet has no receiving errors, and is of legal length.

The look-up engine will insert the qualified SA into the table, along with the port number, time stamp. If the table is full, the last entry of the table will be deleted first to make room for the new entry.

### Migration

The internal look-up engine also monitors whether a station is moved. If it happens, it will update the table accordingly. Migration happens when the following conditions are met:

- The received packet's SA is in the table but the associated source port information is different.
- The received packet is good; the packet has no receiving errors, and is of legal length.

The look-up engine will update the existing record in the table with the new source port information.

### Aging

The look-up engine will update time stamp information of a record whenever the corresponding SA appears. The time stamp is used in the aging process. If a record is not updated for a period of time, the look-up engine will then remove the record from the table. The look-up engine constantly performs the aging process and will continuously remove aging records. The aging period is 300 seconds. This feature can be enabled or disabled by external pull-up or pull-down resistors.

### Forwarding

The KS8999 will forward packets as follows:

- If the DA look-up results is a "match", the KS8999 will use the destination port information to determine where the packet goes.
- If the DA look-up result is a "miss", the KS8999 will forward the packet to all other ports except the port that received the packet.
- All the multicast and broadcast packets will be forwarded to all other ports except the source port.

The KS8999 will not forward the following packets:

- Error packets. These include framing errors, FCS errors, alignment errors, and illegal size packet errors.
- 802.3x pause frames. The KS8999 will intercept these packets and do the appropriate actions.
- "Local" packets. Based on destination address (DA) look-up. If the destination port from the look-up table matches the port where the packet was from, the packet is defined as "local".

### Switching Engine

The KS8999 has a very high performance switching engine to move data to and from the MAC's, packet buffers. It operates in store and forward mode, while the efficient switching mechanism reduces overall latency.

The KS8999 has an internal buffer for frames that is 32Kx32 (128KB). This resource could be shared between the nine ports and is programmed at system reset time by using the unmanaged program mode (I/O strapping).

Each buffer is sized at 128B and therefore there are a total of 1024 buffers available. Two different modes are available for buffer allocation. One mode equally allocates the buffers to all the ports (113 buffers per port). The other mode adaptively allocates buffers up to 512 to a single port based on loading. Selection is achieved by using LED[7][1] in the unmanaged programming description.

### MAC Operation

The KS8999 strictly abides by IEEE 802.3 standard to maximize compatibility.

#### **Inter Packet Gap (IPG)**

If a frame is successfully transmitted, the 96 bit time IPG is measured between the two consecutive MTXEN. If the current packet is experiencing collision, the 96 bit time IPG is measured from MCRS and the next MTXEN.

### **Backoff Algorithm**

The KS8999 implements the IEEE Std 802.3 binary exponential back-off algorithm, and optional “aggressive mode” back off. After 16 collisions, the packet will be optionally dropped depending on the chip configuration.

### **Late Collision**

If a transmit packet experiences collisions after 512 bit times of the transmission, the packet will be dropped.

### **Illegal Frames**

The KS8999 discards frames less than 64 bytes and can be programmed to accept frames up to 1536 bytes. Since the KS8999 supports VLAN tags, the maximum sizing is adjusted when these tags are present.

### **Flow Control**

The KS8999 supports standard 802.3x flow control frames on both transmit and receive sides.

On the receive side, if the KS8999 receives a pause control frame, the KS8999 will not transmit the next normal frame until the timer, specified in the pause control frame, expires. If another pause frame is received before the current timer expires, the timer will be updated with the new value in the second pause frame. During this period (being flow controlled), only flow control packets from the KS8999 will be transmitted.

On the transmit side, the KS8999 has intelligent and efficient ways to determine when to invoke flow control. The flow control is based on availability of the system resources, including available buffers, available transmit queues and available receive queues.

The KS8999 will flow control a port, which just received a packet, if the destination port resource is being used up. The KS8999 will issue a flow control frame (XOFF), containing the maximum pause time defined in IEEE standard 802.3x. Once the resource is freed up, the KS8999 will send out the other flow control frame (XON) with zero pause time to turn off the flow control (turn on transmission to the port). A hysteresis feature is provided to prevent flow control mechanism from being activated and deactivated too many times.

The KS8999 will flow control all ports if the receive queue becomes full.

### **Half Duplex Back Pressure**

Half duplex back pressure option (Note: not in 802.3 standards) is also provided. The activation and deactivation conditions are the same as the above in full duplex mode. If back pressure is required, the KS8999 will send preambles to defer other stations' transmission (carrier sense deference). To avoid jabber and excessive deference defined in 802.3 standard, after a certain time it will discontinue the carrier sense but it will raise the carrier sense quickly. This short silent time (no carrier sense) is to prevent other stations from sending out packets and keeps other stations in carrier sense deferred state. If the port has packets to send during a back pressure situation, the carrier sense type back pressure will be interrupted and those packets will be transmitted instead. If there are no more packets to send, carrier sense type back pressure will be active again until switch resources free up. If a collision occurs, the binary exponential back-off algorithm is skipped and carrier sense is generated immediately, reducing the chance of further colliding and maintaining carrier sense to prevent reception of packets.

### **Broadcast Storm Protection**

The KS8999 has an intelligent option to protect the switch system from receiving too many broadcast packets. Broadcast packets will be forwarded to all ports except the source port, and thus will use too many switch resources (bandwidth and available space in transmit queues). The KS8999 will discard broadcast packets if the number of those packets exceeds the threshold (configured by strapping during reset and EEPROM settings) in a preset period of time. If the preset period expires it will then resume receiving broadcast packets until the threshold is reached. The options are 5% of network line rate for the maximum broadcast receiving threshold or unlimited (feature off).

## MII Interface Operation

The MII (Media Independent Interface) operates in either a MAC or PHY mode. In the MAC mode, the KS8999 MII acts like a MAC and in the PHY mode, it acts like a PHY device. This interface is specified by the IEEE 802.3 committee and provides a common interface between physical layer and MAC layer devices. There are two distinct groups, one being for transmission and the other for receiving. The table below describes the signals used in this interface in MAC and PHY modes.

PHY Mode Connection		Description	MAC Mode Connection	
External MAC Controller Signals	KS8999 PHY Signals		External PHY Signals	KS8999 MAC Signals
MTXEN	MTXEN	Transmit enable	MTXEN	MRXDV
MTXER	MTXER	Transmit error	MTXER	Not used
MTXD3	MTXD[3]	Transmit data bit 3	MTXD3	MRXD[3]
MTXD2	MTXD[2]	Transmit data bit 2	MTXD2	MRXD[2]
MTXD1	MTXD[1]	Transmit data bit 1	MTXD1	MRXD[1]
MTXD0	MTXD[0]	Transmit data bit 0	MTXD0	MRXD[0]
MTXC	MTXC	Transmit clock	MTXC	MTXC
MCOL	MCOL	Collision detection	MCOL	MCOL
MCRS	MCRS	Carrier sense	MCRS	MCRS
MRXDV	MRXDV	Receive data valid	MRXDV	SMTXEN
MRXER	Not used	Receive error	MRXER	MTXER
MRXD3	MRXD[3]	Receive data bit 3	MRXD3	MTXD[3]
MRXD2	MRXD[2]	Receive data bit 2	MRXD2	MTXD[2]
MRXD1	MRXD[1]	Receive data bit 1	MRXD1	MTXD[1]
MRXD0	MRXD[0]	Receive data bit 0	MRXD0	MTXD[0]
MRXC	MRXC	Receive clock	MRXC	MRXC

**Table 1. MII Signals**

This interface is a nibble wide data interface and therefore runs at \_ the network bit rate (not encoded). Additional signals on the transmit side indicate when data is valid or when an error occurs during transmission. Likewise, the receive side has indicators that convey when the data is valid and without physical layer errors.

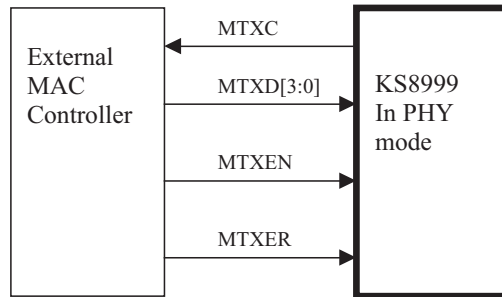
For half-duplex operation there is a signal that indicates a collision has occurred during transmission.



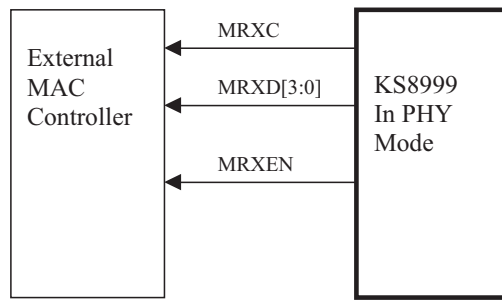
Note that the signal MRXER is not provided on the MII interface for the KS8999 for PHY mode operation and MTXER is not represented for MAC mode. Normally this would indicate a receive / transmit error coming from the physical layer /MAC device, but is not appropriate for this configuration. If the connecting device has a MRXER pin, this should be tied low on the other device for reverse or if it has a MTXER pin in the forward mode it should also be tied low on the other device.

The following explains the KS8999 in PHY mode and MAC mode of operation:

*KS8999 PHY Mode*

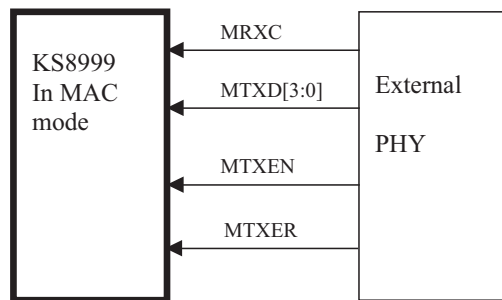


**Figure 3. Data Sent from External MAC Controller to KS8999 PHY Mode**

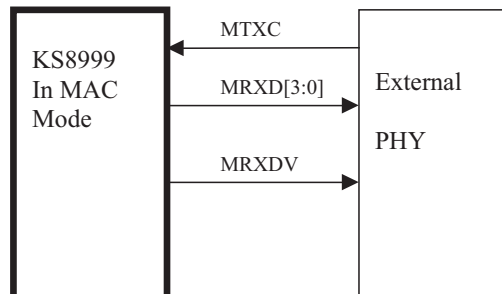


**Figure 4. Data Sent from PHY Mode to External MAC Controller**

*KS8999 MAC Mode*



**Figure 5. Data Sent from PHY Device to KS8999 MAC Mode**



**Figure 6. Data Sent from KS8999 PHY Mode to External PHY Device**

## SNI Interface (7-wire) Operation

The SNI (Serial Network Interface) is compatible with some controllers used for network layer protocol processing. KS8999 acts like a PHY device to external controllers. This interface can be directly connected to these types of devices. The signals are divided into two groups, one being for transmission and the other being the receive side. The signals involved are described in the table below.

SNI Signal	Description	KS8999 SNI Signal	KS8999 Input/Output
TXEN	Transmit enable	MTXEN	Input
TXD	Serial transmit data	MTXD[0]	Input
TXC	Transmit clock	MTXC	Output
COL	Collision detection	MCOL	Output
CRS	Carrier sense	MRXDV	Output
RXD	Serial receive data	MRXD[0]	Output
RXC	Receive clock	MRXC	Output

**Table 2. SNI Signals**

This interface is a bit wide data interface and therefore runs at the network bit rate (not encoded). An additional signal on the transmit side indicates when data is valid. Likewise, the receive side has an indicator that conveys when the data is valid. For half-duplex operation there is a signal that indicate a collision has occurred during transmission.

## Programmable Features

### Priority Schemes

The KS8999 can determine priority through three different means at the ingress point. The first method is a simple per port method, the second is via the 802.1p frame tag and the third is by viewing the DSCP (TOS) field in the IPv4 header. Of course for the priority to be effective, the high and low priority queues must be enabled on the destination port or egress point.

### Per Port Method

General priority can be specified on a per port basis. In this type of priority all traffic from the specified input port is considered high priority in the destination queue. This can be useful in IP phone applications mixed with other data types of traffic where the IP phone connects to a specific port. The IP phone traffic would be high priority (outbound) to the wide area network. The inbound traffic to the IP phone is all of the same priority to the IP phone.

### 802.1p Method

This method works well when used with ports that have mixed data and media flows. The inbound port examines the priority field in the tag and determines the high or low priority. Priority profiles are setup in the Priority Classification Control in the EEPROM.

### IPv4 DSCP Method

This is another per frame way of determining outbound priority. The DSCP (Differentiated Services Code Point – RFC#2474) method uses the TOS field in the IP header to determine high and low priority on a per code point basis. Each fully decoded code point can have either a high or low priority. A larger spectrum of priority flows can be defined with this larger code space. More specific to implementation, the most significant 6 bits of the TOS field are fully decoded into 64 possibilities, and the singular code that results is compared against the corresponding bit in the DSCP register. If the register bit is a 1, the priority is high and if 0, the priority is low.

### Other Priority Considerations

When setting up the priority scheme, one should consider other available controls to regulate the traffic. One of these is Priority Control Scheme (register 2 bits 2-3) which controls the interleaving of high and low priority frames. Options allow from a 2:1 ratio up to a setting that sends all the high priority first. This setting controls all ports globally. Another global feature is Priority Buffer Reserve (register 2 bit 1). If this is set, there is a 6KB (10%) buffer dedicated to high priority traffic, otherwise if cleared the buffer is shared between all traffic.

On an individual port basis there are controls that enable DSCP, 802.1p, port based and high/low priority queues. These are contained in registers 4-12 bits 5-3 and 0. It should be noted that there is a special pin that generally enables the 802.1p priority for all ports (pin 91). When this pin is active (high) all ports will have the 802.1p priority enabled unless specifically disabled by EEPROM programming (bit 4 of registers 4-12). Default high priority is a value greater than 4 in the VLAN tag with low priority being 3 or less.

The table below briefly summarizes priority features. For more detailed settings see the EEPROM register description.

Register(s)	Bit(s)	Global/Port	Description
			<b>General</b>
2	3-2	Global	Priority Control Scheme: Transmit buffer high/low interleave control
2	1	Global	Priority Buffer Reserve: Reserves 6KB of the buffer for high priority traffic
4-12	0	Port	Enable Port Queue Split: Splits the transmit queue on the desired port for high and low priority traffic
			<b>DSCP Priority</b>
4-12	5	Port	Enable Port DSCP: Looks at DSCP field in IP header to decide high or low priority
40-47	7-0	Global	DSCP Priority Points: Fully decoded 64 bit register used to determine priority from DSCP field (6 bits) in the IP header
			<b>802.1p Priority</b>
4-12	4	Port	Enable Port 802.1p Priority: Uses the 802.1p priority tag (3 bits) to determine frame priority
3	7-0	Global	Priority Classification: Determines which tag values have high priority
			<b>Per Port Priority</b>
4-12	3	Port	Enable Port Priority: Determines which ports have high or low priority traffic

**Table 3. Priority Control**

## VLAN Operation

The VLAN's are setup by programming the VLAN Mask Registers in the EEPROM. The perspective of the VLAN is from the input port and which output ports it sees directly through the switch. For example if port 1 only participated in a VLAN with ports 2 and 9 then one would set bits 0 and 7 in register 13 (Port 1 VLAN Mask Register). Note that different ports can be setup independently. An example of this would be where a router is connected to port 9 and each of the other ports would work autonomously. In this configuration ports 1 through 8 would only set the mask for port 9 and port 9 would set the mask for ports 1 through 8. In this way, the router could see all ports and each of the other individual ports would only communicate with the router.

All multicast and broadcast frames adhere to the VLAN configuration. Unicast frame treatment is a function of register 2 bit 0. If this bit is set then unicast frames only see ports within their VLAN. If this bit is cleared unicast frames can traverse VLAN's.

VLAN tags can be added or removed on a per port basis. Further, there are provisions to specify the tag value to be inserted on a per port basis.

The table below briefly summarizes VLAN features. For more detailed settings see the EEPROM register description.

Register(s)	Bit(s)	Global/Port	Description
4-12	2	Port	Insert VLAN Tags: If specified, will add VLAN tags to frames without existing tags
4-12	1	Port	Strip VLAN Tags: If specified, will remove VLAN tags from frames if they exist
2	0	Global	VLAN Enforcement: Allows unicast frames to adhere or ignore the VLAN configuration
13-21	7-0	Port	VLAN Mask Registers: Allows configuration of individual VLAN grouping.
22-39	7-0	Port	VLAN Tag Insertion Values: Specifies the VLAN tag to be inserted if enabled (see above)

**Table 4. VLAN Control**

## Station MAC Address (control frames only)

The MAC source address can be programmed as used in flow control frames. The table below briefly summarizes this programmable feature.

Register(s)	Bit(s)	Global/Port	Description
48-53	7-0	Global	Station MAC Address: Used as source address for MAC control frames as used in full duplex flow control mechanisms.

**Table 5. Misc. Control**

## EEPROM Operation

The EEPROM interface utilizes 2 pins that provide a clock and a serial data path. As part of the initialization sequence, the KS8999 reads the contents of the EEPROM and loads the values into the appropriate registers. Note that the first two bytes in the EEPROM must be “55” and “99” respectively for the loading to occur properly. If these first two values are not correct, all other data will be ignored.

Data start and stop conditions are signaled on the data line as a state transition during clock high time. A high to low transition indicates start of data and a low to high transition indicates a stop condition. The actual data that traverses the serial line changes during the clock low time.

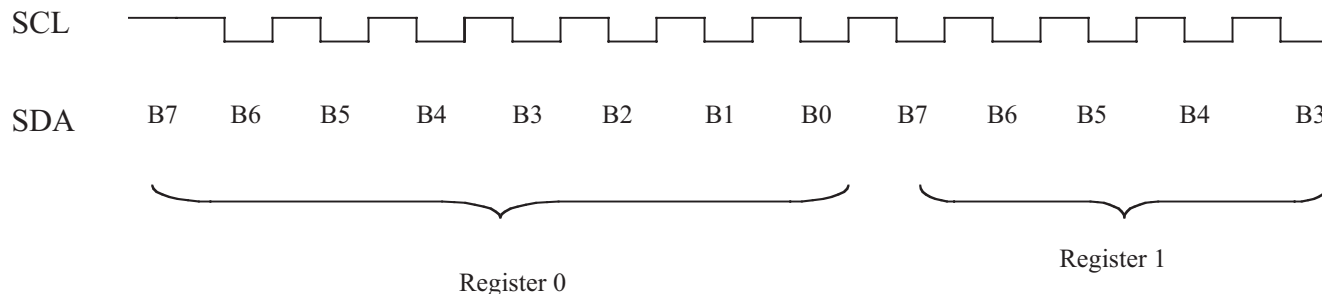
The KS8999 EEPROM interface is compatible with the Atmel AT24C01A part. Address A0, A1 and A2 are fixed to 000. Further timing and data sequences can be found in the Atmel AT24C01A specification.

## Optional CPU Interface

Instead of using an EEPROM to program the KS8999, one can use an external processor. To utilize this feature, the CFGMODE pin (only available on the 208 pin package) needs to be pulled low. This makes the KS8999 serial and clock interface into a slave rather than a master. In this mode, clock and data are sourced from the processor.

Due to timing constraints, the maximum clock speed that the processor can generate is 8MHz. Data timing is referenced to the rising edge of the clock and are 10ns for setup and 60ns for hold. The processor needs to supply the exact number of clock cycles and data bits to program the KS8999 properly. KS8999 won't start until all of the registers are programmed. Bits are loaded from high order (bit 7) to low order (bit 0) starting with register 0 and finishing with register 53.

Register 0:	Skip clock on first bit 7	SCL clock cycle: 7
Register 1 to Register 53:	provide clock on bit 7 to bit 0	SCL clock cycle: 424
		Total SCL clock cycle: 431



## EEPROM Memory Map

Address	Name	Description	Default (chip) Value
0	7-0	Signature byte 1. Value = "55"	0x55
1	7-0	Signature byte 2. Value = "99"	0x99
<b>General Control Register</b>			
2	7-4	Reserved – set to zero	0000
2	3-2	Priority control scheme (all ports) 00 = Transmit all high priority before any low priority 01 = Transmit high and low priority at a 10:1 ratio 10 = Transmit high and low priority at a 5:1 ratio 11 = Transmit high and low priority at a 2:1 ratio	00
2	1	Priority buffer reserve for high priority traffic 1 = Reserve 6KB of buffer space for high priority 0 = None reserved	0
2	0	VLAN enforcement 1 = All unicast frames adhere to VLAN configuration 0 = Unicast frames ignore VLAN configuration	0
<b>Priority Classification Control – 802.1p tag field</b>			
3	7	1 = State "111" is high priority 0 = State "111" is low priority	1
3	6	1 = State "110" is high priority 0 = State "110" is low priority	1
3	5	1 = State "101" is high priority 0 = State "101" is low priority	1
3	4	1 = State "100" is high priority 0 = State "100" is low priority	1
3	3	1 = State "011" is high priority 0 = State "011" is low priority	0
3	2	1 = State "010" is high priority 0 = State "010" is low priority	0
3	1	1 = State "001" is high priority 0 = State "001" is low priority	0
3	0	1 = State "000" is high priority 0 = State "000" is low priority	0
<b>Port 1 Control Register</b>			
4	7-6	Reserved – set to zero	00
4	5	TOS priority classification enable for port 1 1 = Enable 0 = Disable	0
4	4	802.1p priority classification enable for port 1 1 = Enable 0 = Disable	0
4	3	Port based priority classification for port 1 1 = High priority 0 = Low priority	0
4	2	Insert VLAN tags for port 1 if non-existent 1 = Enable 0 = Disable	0
4	1	Strip VLAN tags for port 1 if existent 1 = Enable 0 = Disable	0

Address	Name	Description	Default (chip) Value
4	0	Enable high and low output priority queues for port 1 1 = Enable 0 = Disable	0
<b>Port 2 Control Register</b>			
5	7-6	Reserved – set to zero	00
5	5	TOS priority classification enable for port 2 1 = Enable 0 = Disable	0
5	4	802.1p priority classification enable for port 2 1 = Enable 0 = Disable	0
5	3	Port based priority classification for port 2 1 = High priority 0 = Low priority	0
5	2	Insert VLAN tags for port 2 if non-existent 1 = Enable 0 = Disable	0
5	1	Strip VLAN tags for port 2 if existent 1 = Enable 0 = Disable	0
5	0	Enable high and low output priority queues for port 2 1 = Enable 0 = Disable	0
<b>Port 3 Control Register</b>			
6	7-6	Reserved – set to zero	00
6	5	TOS priority classification enable for port 3 1 = Enable 0 = Disable	0
6	4	802.1p priority classification enable for port 3 1 = Enable 0 = Disable	0
6	3	Port based priority classification for port 3 1 = High priority 0 = Low priority	0
6	2	Insert VLAN tags for port 3 if non-existent 1 = Enable 0 = Disable	0
6	1	Strip VLAN tags for port 3 if existent 1 = Enable 0 = Disable	0
6	0	Enable high and low output priority queues for port 3 1 = Enable 0 = Disable	0
<b>Port 4 Control Register</b>			
7	7-6	Reserved – set to zero	00
7	5	TOS priority classification enable for port 4 1 = Enable 0 = Disable	0
7	4	802.1p priority classification enable for port 4 1 = Enable 0 = Disable	0

Address	Name	Description	Default (chip) Value
7	3	Port based priority classification for port 4 1 = High priority 0 = Low priority	0
7	2	Insert VLAN tags for port 4 if non-existent 1 = Enable 0 = Disable	0
7	1	Strip VLAN tags for port 4 if existent 1 = Enable 0 = Disable	0
7	0	Enable high and low output priority queues for port 4 1 = Enable 0 = Disable	0
<b>Port 5 Control Register</b>			
8	7-6	Reserved – set to zero	00
8	5	TOS priority classification enable for port 5 1 = Enable 0 = Disable	0
8	4	802.1p priority classification enable for port 5 1 = Enable 0 = Disable	0
8	3	Port based priority classification for port 5 1 = High priority 0 = Low priority	0
8	2	Insert VLAN tags for port 5 if non-existent 1 = Enable 0 = Disable	0
8	1	Strip VLAN tags for port 5 if existent 1 = Enable 0 = Disable	0
8	0	Enable high and low output priority queues for port 5 1 = Enable 0 = Disable	0
<b>Port 6 Control Register</b>			
9	7-6	Reserved – set to zero	00
9	5	TOS priority classification enable for port 6 1 = Enable 0 = Disable	0
9	4	802.1p priority classification enable for port 6 1 = Enable 0 = Disable	0
9	3	Port based priority classification for port 6 1 = High priority 0 = Low priority	0
9	2	Insert VLAN tags for port 6 if non-existent 1 = Enable 0 = Disable	0
9	1	Strip VLAN tags for port 6 if existent 1 = Enable 0 = Disable	0
9	0	Enable high and low output priority queues for port 6 1 = Enable 0 = Disable	0

Address	Name	Description	Default (chip) Value
<b>Port 7 Control Register</b>			
10	7-6	Reserved – set to zero	00
10	5	TOS priority classification enable for port 7 1 = Enable 0 = Disable	0
10	4	802.1p priority classification enable for port 7 1 = Enable 0 = Disable	0
10	3	Port based priority classification for port 7 1 = High priority 0 = Low priority	0
10	2	Insert VLAN tags for port 7 if non-existent 1 = Enable 0 = Disable	0
10	1	Strip VLAN tags for port 7 if existent 1 = Enable 0 = Disable	0
10	0	Enable high and low output priority queues for port 7 1 = Enable 0 = Disable	0
<b>Port 8 Control Register</b>			
11	7-6	Reserved – set to zero	00
11	5	TOS priority classification enable for port 8 1 = Enable 0 = Disable	0
11	4	802.1p priority classification enable for port 8 1 = Enable 0 = Disable	0
11	3	Port based priority classification for port 8 1 = High priority 0 = Low priority	0
11	2	Insert VLAN tags for port 8 if non-existent 1 = Enable 0 = Disable	0
11	1	Strip VLAN tags for port 8 if existent 1 = Enable 0 = Disable	0
11	0	Enable high and low output priority queues for port 8 1 = Enable 0 = Disable	0
<b>Port 9 Control Register</b>			
12	7-6	Reserved – set to zero	00
12	5	TOS priority classification enable for port 9 1 = Enable 0 = Disable	0
12	4	802.1p priority classification enable for port 9 1 = Enable 0 = Disable	0
12	3	Port based priority classification for port 9 1 = High priority 0 = Low priority	0



Address	Name	Description	Default (chip) Value
12	2	Insert VLAN tags for port 9 if non-existent 1 = Enable 0 = Disable	0
12	1	Strip VLAN tags for port 9 if existent 1 = Enable 0 = Disable	0
12	0	Enable high and low output priority queues for port 9 1 = Enable 0 = Disable	0
<b>Port 1 VLAN Mask Register</b>			
13	7	Port 9 inclusion 1 = Port 9 in the same VLAN as port 1 0 = Port 9 not in the same VLAN as port 1	1
13	6	Port 8 inclusion 1 = Port 8 in the same VLAN as port 1 0 = Port 8 not in the same VLAN as port 1	1
13	5	Port 7 inclusion 1 = Port 7 in the same VLAN as port 1 0 = Port 7 not in the same VLAN as port 1	1
13	4	Port 6 inclusion 1 = Port 6 in the same VLAN as port 1 0 = Port 6 not in the same VLAN as port 1	1
13	3	Port 5 inclusion 1 = Port 5 in the same VLAN as port 1 0 = Port 5 not in the same VLAN as port 1	1
13	2	Port 4 inclusion 1 = Port 4 in the same VLAN as port 1 0 = Port 4 not in the same VLAN as port 1	1
13	1	Port 3 inclusion 1 = Port 3 in the same VLAN as port 1 0 = Port 3 not in the same VLAN as port 1	1
13	0	Port 2 inclusion 1 = Port 2 in the same VLAN as port 1 0 = Port 2 not in the same VLAN as port 1	1
<b>Port 2 VLAN Mask Register</b>			
14	7	Port 9 inclusion 1 = Port 9 in the same VLAN as port 2 0 = Port 9 not in the same VLAN as port 2	1
14	6	Port 8 inclusion 1 = Port 8 in the same VLAN as port 2 0 = Port 8 not in the same VLAN as port 2	1
14	5	Port 7 inclusion 1 = Port 7 in the same VLAN as port 2 0 = Port 7 not in the same VLAN as port 2	1
14	4	Port 6 inclusion 1 = Port 6 in the same VLAN as port 2 0 = Port 6 not in the same VLAN as port 2	1
14	3	Port 5 inclusion 1 = Port 5 in the same VLAN as port 2 0 = Port 5 not in the same VLAN as port 2	1
14	2	Port 4 inclusion 1 = Port 4 in the same VLAN as port 2 0 = Port 4 not in the same VLAN as port 2	1

Address	Name	Description	Default (chip) Value
14	1	Port 3 inclusion 1 = Port 3 in the same VLAN as port 2 0 = Port 3 not in the same VLAN as port 2	1
14	0	Port 1 inclusion 1 = Port 1 in the same VLAN as port 2 0 = Port 1 not in the same VLAN as port 2	1
<b>Port 3 VLAN Mask Register</b>			
15	7	Port 9 inclusion 1 = Port 9 in the same VLAN as port 3 0 = Port 9 not in the same VLAN as port 3	1
15	6	Port 8 inclusion 1 = Port 8 in the same VLAN as port 3 0 = Port 8 not in the same VLAN as port 3	1
15	5	Port 7 inclusion 1 = Port 7 in the same VLAN as port 3 0 = Port 7 not in the same VLAN as port 3	1
15	4	Port 6 inclusion 1 = Port 6 in the same VLAN as port 3 0 = Port 6 not in the same VLAN as port 3	1
15	3	Port 5 inclusion 1 = Port 5 in the same VLAN as port 3 0 = Port 5 not in the same VLAN as port 3	1
15	2	Port 4 inclusion 1 = Port 4 in the same VLAN as port 3 0 = Port 4 not in the same VLAN as port 3	1
15	1	Port 2 inclusion 1 = Port 2 in the same VLAN as port 3 0 = Port 2 not in the same VLAN as port 3	1
15	0	Port 1 inclusion 1 = Port 1 in the same VLAN as port 3 0 = Port 1 not in the same VLAN as port 3	1
<b>Port 4 VLAN Mask Register</b>			
16	7	Port 9 inclusion 1 = Port 9 in the same VLAN as port 4 0 = Port 9 not in the same VLAN as port 4	1
16	6	Port 8 inclusion 1 = Port 8 in the same VLAN as port 4 0 = Port 8 not in the same VLAN as port 4	1
16	5	Port 7 inclusion 1 = Port 7 in the same VLAN as port 4 0 = Port 7 not in the same VLAN as port 4	1
16	4	Port 6 inclusion 1 = Port 6 in the same VLAN as port 4 0 = Port 6 not in the same VLAN as port 4	1
16	3	Port 5 inclusion 1 = Port 5 in the same VLAN as port 4 0 = Port 5 not in the same VLAN as port 4	1
16	2	Port 3 inclusion 1 = Port 3 in the same VLAN as port 4 0 = Port 3 not in the same VLAN as port 4	1
16	1	Port 2 inclusion 1 = Port 2 in the same VLAN as port 4 0 = Port 2 not in the same VLAN as port 4	1

Address	Name	Description	Default (chip) Value
16	0	Port 1 inclusion 1 = Port 1 in the same VLAN as port 4 0 = Port 1 not in the same VLAN as port 4	1
<b>Port 5 VLAN Mask Register</b>			
17	7	Port 9 inclusion 1 = Port 9 in the same VLAN as port 5 0 = Port 9 not in the same VLAN as port 5	1
17	6	Port 8 inclusion 1 = Port 8 in the same VLAN as port 5 0 = Port 8 not in the same VLAN as port 5	1
17	5	Port 7 inclusion 1 = Port 7 in the same VLAN as port 5 0 = Port 7 not in the same VLAN as port 5	1
17	4	Port 6 inclusion 1 = Port 6 in the same VLAN as port 5 0 = Port 6 not in the same VLAN as port 5	1
17	3	Port 4 inclusion 1 = Port 4 in the same VLAN as port 5 0 = Port 4 not in the same VLAN as port 5	1
17	2	Port 3 inclusion 1 = Port 3 in the same VLAN as port 5 0 = Port 3 not in the same VLAN as port 5	1
17	1	Port 2 inclusion 1 = Port 2 in the same VLAN as port 5 0 = Port 2 not in the same VLAN as port 5	1
17	0	Port 1 inclusion 1 = Port 1 in the same VLAN as port 5 0 = Port 1 not in the same VLAN as port 5	1
<b>Port 6 VLAN Mask Register</b>			
18	7	Port 9 inclusion 1 = Port 9 in the same VLAN as port 6 0 = Port 9 not in the same VLAN as port 6	1
18	6	Port 8 inclusion 1 = Port 8 in the same VLAN as port 6 0 = Port 8 not in the same VLAN as port 6	1
18	5	Port 7 inclusion 1 = Port 7 in the same VLAN as port 6 0 = Port 7 not in the same VLAN as port 6	1
18	4	Port 5 inclusion 1 = Port 5 in the same VLAN as port 6 0 = Port 5 not in the same VLAN as port 6	1
18	3	Port 4 inclusion 1 = Port 4 in the same VLAN as port 6 0 = Port 4 not in the same VLAN as port 6	1
18	2	Port 3 inclusion 1 = Port 3 in the same VLAN as port 6 0 = Port 3 not in the same VLAN as port 6	1
18	1	Port 2 inclusion 1 = Port 2 in the same VLAN as port 6 0 = Port 2 not in the same VLAN as port 6	1
18	0	Port 1 inclusion 1 = Port 1 in the same VLAN as port 6 0 = Port 1 not in the same VLAN as port 6	1

Address	Name	Description	Default (chip) Value
<b>Port 7 VLAN Mask Register</b>			
19	7	Port 9 inclusion 1 = Port 9 in the same VLAN as port 7 0 = Port 9 not in the same VLAN as port 7	1
19	6	Port 8 inclusion 1 = Port 8 in the same VLAN as port 7 0 = Port 8 not in the same VLAN as port 7	1
19	5	Port 6 inclusion 1 = Port 6 in the same VLAN as port 7 0 = Port 6 not in the same VLAN as port 7	1
19	4	Port 5 inclusion 1 = Port 5 in the same VLAN as port 7 0 = Port 5 not in the same VLAN as port 7	1
19	3	Port 4 inclusion 1 = Port 4 in the same VLAN as port 7 0 = Port 4 not in the same VLAN as port 7	1
19	2	Port 3 inclusion 1 = Port 3 in the same VLAN as port 7 0 = Port 3 not in the same VLAN as port 7	1
19	1	Port 2 inclusion 1 = Port 2 in the same VLAN as port 7 0 = Port 2 not in the same VLAN as port 7	1
19	0	Port 1 inclusion 1 = Port 1 in the same VLAN as port 7 0 = Port 1 not in the same VLAN as port 7	1
<b>Port 8 VLAN Mask Register</b>			
20	7	Port 9 inclusion 1 = Port 9 in the same VLAN as port 8 0 = Port 9 not in the same VLAN as port 8	1
20	6	Port 7 inclusion 1 = Port 7 in the same VLAN as port 8 0 = Port 7 not in the same VLAN as port 8	1
20	5	Port 6 inclusion 1 = Port 6 in the same VLAN as port 8 0 = Port 6 not in the same VLAN as port 8	1
20	4	Port 5 inclusion 1 = Port 5 in the same VLAN as port 8 0 = Port 5 not in the same VLAN as port 8	1
20	3	Port 4 inclusion 1 = Port 4 in the same VLAN as port 8 0 = Port 4 not in the same VLAN as port 8	1
20	2	Port 3 inclusion 1 = Port 3 in the same VLAN as port 8 0 = Port 3 not in the same VLAN as port 8	1
20	1	Port 2 inclusion 1 = Port 2 in the same VLAN as port 8 0 = Port 2 not in the same VLAN as port 8	1
20	0	Port 1 inclusion 1 = Port 1 in the same VLAN as port 8 0 = Port 1 not in the same VLAN as port 8	1

Address	Name	Description	Default (chip) Value
<b>Port 9 VLAN Mask Register</b>			
21	7	Port 8 inclusion 1 = Port 8 in the same VLAN as port 9 0 = Port 8 not in the same VLAN as port 9	1
21	6	Port 7 inclusion 1 = Port 7 in the same VLAN as port 9 0 = Port 7 not in the same VLAN as port 9	1
21	5	Port 6 inclusion 1 = Port 6 in the same VLAN as port 9 0 = Port 6 not in the same VLAN as port 9	1
21	4	Port 5 inclusion 1 = Port 5 in the same VLAN as port 9 0 = Port 5 not in the same VLAN as port 9	1
21	3	Port 4 inclusion 1 = Port 4 in the same VLAN as port 9 0 = Port 4 not in the same VLAN as port 9	1
21	2	Port 3 inclusion 1 = Port 3 in the same VLAN as port 9 0 = Port 3 not in the same VLAN as port 9	1
21	1	Port 2 inclusion 1 = Port 2 in the same VLAN as port 9 0 = Port 2 not in the same VLAN as port 9	1
21	0	Port 1 inclusion 1 = Port 1 in the same VLAN as port 9 0 = Port 1 not in the same VLAN as port 9	1
<b>Port 1 VLAN Tag Insertion Value Registers</b>			
22	7-5	User priority [2:0]	000
22	4	CFI	0
22	3-0	VID [11:8]	0x0
23	7-0	VID [7:0]	0x00
<b>Port 2 VLAN Tag Insertion Value Registers</b>			
24	7-5	User priority [2:0]	000
24	4	CFI	0
24	3-0	VID [11:8]	0x0
25	7-0	VID [7:0]	0x00
<b>Port 3 VLAN Tag Insertion Value Registers</b>			
26	7-5	User priority [2:0]	000
26	4	CFI	0
26	3-0	VID [11:8]	0x0
27	7-0	VID [7:0]	0x00
<b>Port 4 VLAN Tag Insertion Value Registers</b>			
28	7-5	User priority [2:0]	000
28	4	CFI	0
28	3-0	VID [11:8]	0x0
29	7-0	VID [7:0]	0x00

Address	Name	Description	Default (chip) Value
<b>Port 5 VLAN Tag Insertion Value Registers</b>			
30	7-5	User priority [2:0]	000
30	4	CFI	0
30	3-0	VID [11:8]	0x0
31	7-0	VID [7:0]	0x00
<b>Port 6 VLAN Tag Insertion Value Registers</b>			
32	7-5	User priority [2:0]	000
32	4	CFI	0
32	3-0	VID [11:8]	0x0
33	7-0	VID [7:0]	0x00
<b>Port 7 VLAN Tag Insertion Value Registers</b>			
34	7-5	User priority [2:0]	000
34	4	CFI	0
34	3-0	VID [11:8]	0x0
35	7-0	VID [7:0]	0x00
<b>Port 8 VLAN Tag Insertion Value Registers</b>			
36	7-5	User priority [2:0]	000
36	4	CFI	0
36	3-0	VID [11:8]	0x0
37	7-0	VID [7:0]	0x00
<b>Port 9 VLAN Tag Insertion Value Registers</b>			
38	7-5	User priority [2:0]	000
38	4	CFI	0
38	3-0	VID [11:8]	0x0
39	7-0	VID [7:0]	0x00
<b>Diff Serv Code Point Registers</b>			
40	7-0	DSCP[63:56]	0x00
41	7-0	DSCP[55:48]	0x00
42	7-0	DSCP[47:40]	0x00
43	7-0	DSCP[39:32]	0x00
44	7-0	DSCP[31:24]	0x00
45	7-0	DSCP[23:16]	0x00
46	7-0	DSCP[15:8]	0x00
47	7-0	DSCP[7:0]	0x00
<b>Station MAC Address Registers (all ports – MAC control frames only)</b>			
48	7-0	MAC address [47:40]	0x00
49	7-0	MAC address [39:32]	0x40
50	7-0	MAC address [31:24]	0x05
51	7-0	MAC address [23:16]	0x43
52	7-0	MAC address [15:8]	0x5E
53	7-0	MAC address [7:0]	0xFE

Note: The MAC address is reset to the value in the above table, but can set to any value via the EEPROM interface. This MAC address is used as the source address in MAC control frames that execute flow control between link peers.

**Absolute Maximum Ratings (Note 1)**

Supply Voltage ( $V_{DD\_RX}$ , $V_{DD\_TX}$ , $V_{DD\_RCV}$ , $V_{DD}$ , $V_{DD\_PLLTX}$ )	.....	-0.5V to +2.3V
( $V_{DDIO}$ )	.....	-0.5V to +3.8V
Input Voltage	.....	-0.5V to +4.0V
Output Voltage	.....	-0.5V to +4.0V
Lead Temperature (soldering, 10 sec.)	.....	270°C
Storage Temperature ( $T_S$ )	.....	-55°C to +150°C

**Operating Ratings (Note 2)**

Supply Voltage ( $V_{DD\_RX}$ , $V_{DD\_TX}$ , $V_{DD\_RCV}$ , $V_{DD}$ , $V_{DD\_PLLTX}$ )	.....	+2.0V to +2.3V
( $V_{DDIO}$ )	.....	+2.0V to +2.3V or +3.0V to +3.6V
Ambient Temperature ( $T_A$ )	.....	-0°C to +70°C
Commercial	.....	-0°C to +70°C
Industrial	.....	-40°C to +85°C
Package Thermal Resistance, (Note 3) PQFP ( $\theta_{JA}$ ) No Air Flow	.....	39.1°C/W

**Electrical Characteristics (KS8999) (Note 4)**

$V_{DD} = 2.0V$  to  $2.3V$ ;  $T_A = 0^\circ C$  to  $+70^\circ C$ ; unless noted.

Symbol	Parameter	Condition	Min	Typ	Max	Units
$V_{DD}$	Supply Voltage		2.00	2.10	2.30	V

**Supply Current (including TX output driver current)**

100BaseTX Operation—Total			Min	Typ	Max	Units
				0.64	0.85	A
$I_{DX}$	100BaseTX (Transmitter)			0.35	0.40	A
$I_{DA}$	100BaseTX (Analog)			0.18	0.25	A
$I_{DD}$	100BaseTX (Digital)			0.11	0.20	A
10BaseT Operation—Total			Min	Typ	Max	Units
				1.04	1.32	A
$I_{DX}$	100BaseTX (Transmitter)			0.84	0.95	A
$I_{DA}$	100BaseTX (Analog)			0.11	0.17	A
$I_{DD}$	100BaseTX (Digital)			0.09	0.20	A

**TTL Inputs**

$V_{IH}$	Input High Voltage		$(1/2 V_{DDIO})$ +0.4			V
$V_{IL}$	Input Low Voltage				$(1/2 V_{DDIO})$ -0.4	V
$I_{IN}$	Input Current	$V_{IN} = GND \sim V_{DD}$	-10		10	$\mu A$

**TTL Outputs**

$V_{OH}$	Output High Voltage	$I_{OH} = -4mA$	$V_{DDIO}$ -0.4			V
$V_{OL}$	Output Low Voltage	$I_{OL} = 4mA$			+0.4	V
$ I_{OZ} $	Output Tri-State Leakage				10	$\mu A$

**100BaseTX Transmit (measured differentially after 1:1 transformer)**

$V_O$	Peak Differential Output Voltage	50 $\Omega$ from each output to $V_{DD}$	0.95		1.05	V
$V_{IMB}$	Output Voltage Imbalance	50 $\Omega$ from each output to $V_{DD}$			2	%
$t_r, t_f$	Rise/Fall Time		3		5	ns
	Rise/Fall Time Imbalance		0		0.5	ns

**Note 1.** Exceeding the absolute maximum rating may damage the device.

**Note 2.** The device is not guaranteed to function outside its operating rating. Unused inputs must always be tied to an appropriate logic voltage level (Ground to  $V_{DD}$ ).

**Note 3.** No HS (heat spreader) in package.

**Note 4.** Specification for packaged product only.

Symbol	Parameter	Condition	Min	Typ	Max	Units
<b>100BaseTX Transmit (measured differentially after 1:1 transformer)</b>						
	Duty Cycle Distortion				±0.5	ns
	Overshoot				5	%
V <sub>SET</sub>	Reference Voltage of ISET			0.75		V
	Output Jitters	Peak-to-peak		0.7	1.4	ns
<b>10BaseTX Receive</b>						
V <sub>SQ</sub>	Squelch Threshold	5MHz square wave		400		mV
<b>10BaseT Transmit (measured differentially after 1:1 transformer)</b>						
V <sub>P</sub>	Peak Differential Output Voltage	50Ω from each output to V <sub>DD</sub>		2.3		V
	Jitters Added	50Ω from each output to V <sub>DD</sub>			±3.5	ns
	Rise/Fall Times			28		ns



## Timing Diagrams

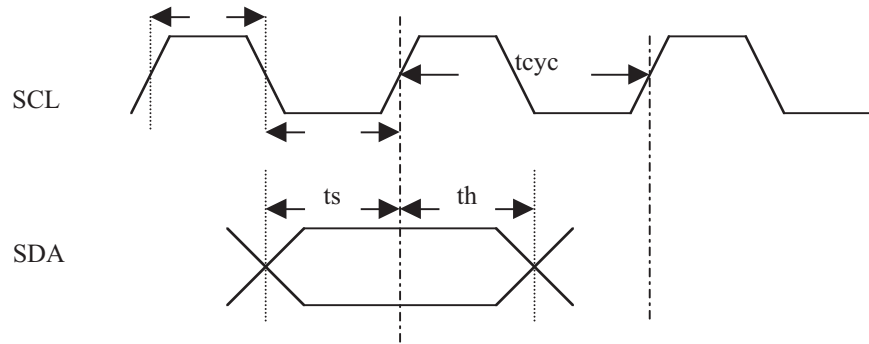


Figure 7. EEPROM Input Timing

Symbol	Parameter	Min	Typ	Max	Units
$t_{CYC}$	Clock Cycle		16384		ns
$t_S$	Set-Up Time	20			ns
$t_H$	Hold Time	20			ns

Table 5. EEPROM Input Timing Parameters

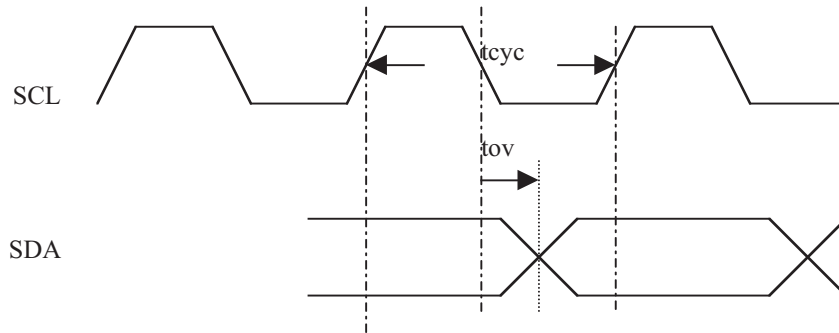


Figure 8. EEPROM Output Timing

Symbol	Parameter	Min	Typ	Max	Units
$t_{CYC}$	Clock Cycle		16384		ns
$t_{OV}$	Output Valid	4096	4112	4128	ns

Table 6. EEPROM Output Timing Parameters

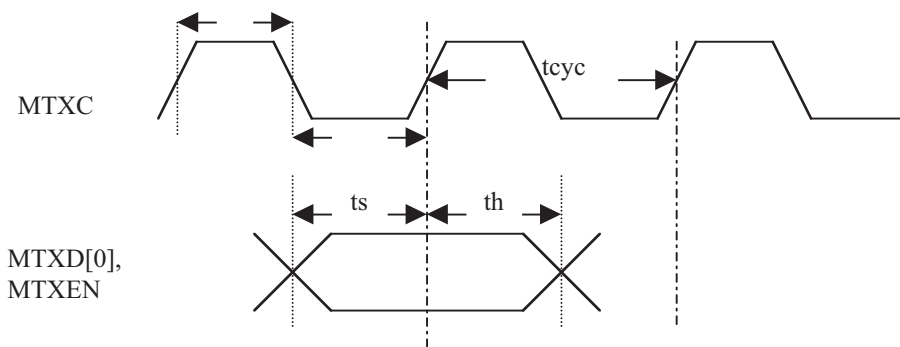


Figure 9. SNI (7-wire) Input Timing

Symbol	Parameter	Min	Typ	Max	Units
$t_{CYC}$	Clock Cycle		100		ns
$t_S$	Set-Up Time	10			ns
$t_H$	Hold Time	0			ns

Table 7. SNI (7-wire) Input Parameters

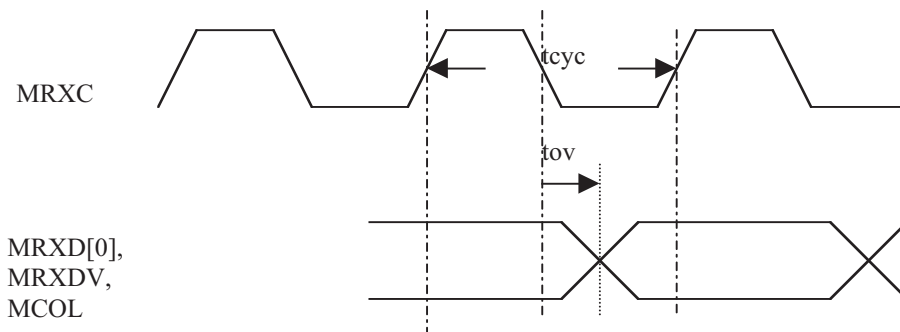


Figure 10. SNI (7-wire) Output Timing

Symbol	Parameter	Min	Typ	Max	Units
$t_{CYC}$	Clock Cycle		100		ns
$t_{OV}$	Output Valid	0	3	6	ns

Table 8. SNI (7-wire) Output Timing Parameters

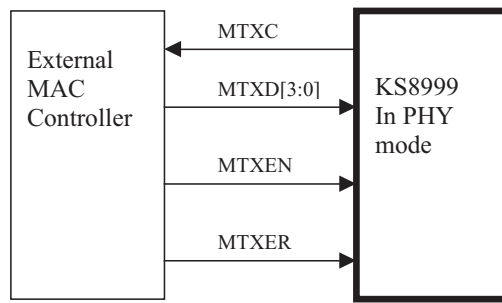


Figure 11. KS8999 PHY Mode—Data Sent from External MAC Controller to KS8999

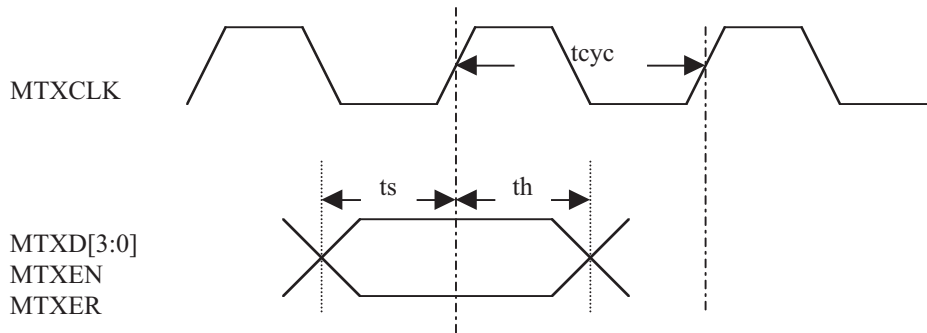


Figure 12. KS8999 PHY Mode Receive Timing

Symbol	Parameter	Min	Typ	Max	Units
$t_{CYC}$	Clock Cycle (100BaseT)		40		ns
$t_{CYC}$	Clock Cycle (10BaseT)		400		ns
$t_S$	Set-Up Time	10			ns
$t_H$	Hold Time	0			ns

Table 9. MII Timing in KS8999 PHY and MAC Mode Timing Parameters

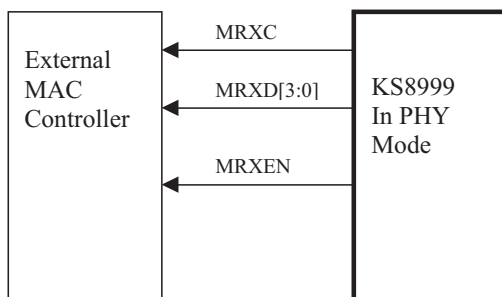


Figure 13. KS8999 PHY Mode—Data Sent from KS8999 PHY Mode to External MAC Controller

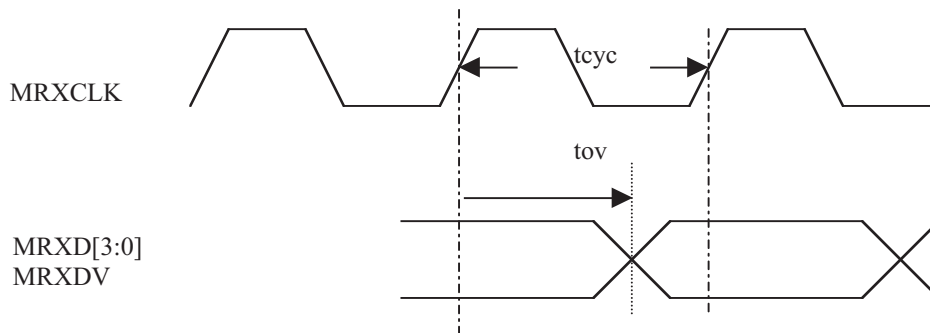


Figure 14. KS8999 PHY Mode Transmit Timing

Symbol	Parameter	Min	Typ	Max	Units
$t_{CYC}$	Clock Cycle (100BaseT)		40		ns
$t_{CYC}$	Clock Cycle (10BaseT)		400		ns
$t_{OV}$	Output Valid	18	25	28	ns

Table 10. KS8999 PHY Mode Transmit Timing Parameters

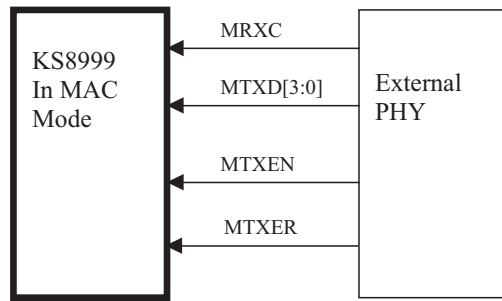


Figure 15. KS8999 MAC Mode—Data Sent from External PHY Device to KS8999

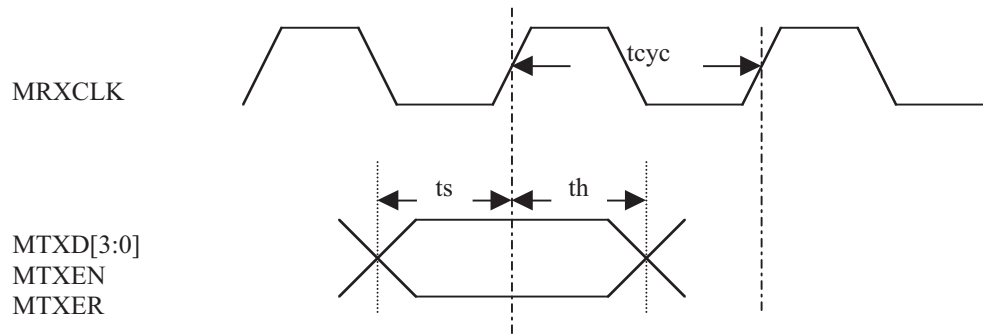


Figure 16. KS8999 MAC Mode Receive Timing

Symbol	Parameter	Min	Typ	Max	Units
$t_{CYC}$	Clock Cycle (100BaseT)		40		ns
$t_{CYC}$	Clock Cycle (10BaseT)		400		ns
$t_S$	Output Valid	10			ns
$t_H$	Output Valid	5			ns

Table 11. KS8999 PHY Mode Transmit Timing Parameters

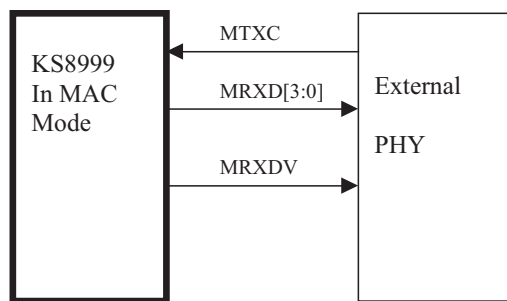


Figure 17. KS8999 MAC Mode Timing—Data Sent from KS8999 MAC mode to External PHY Device

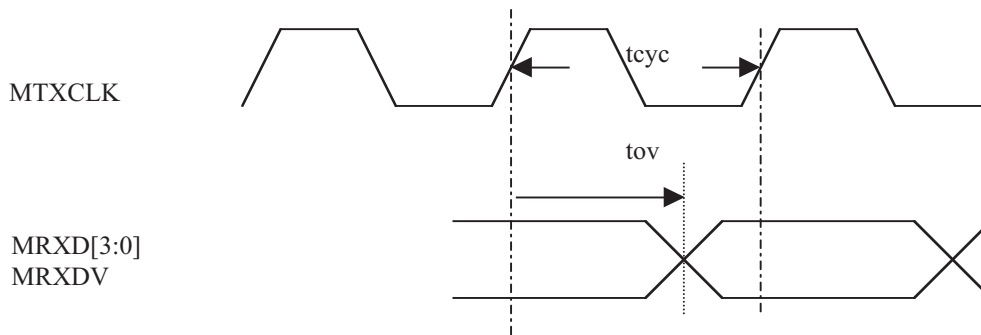


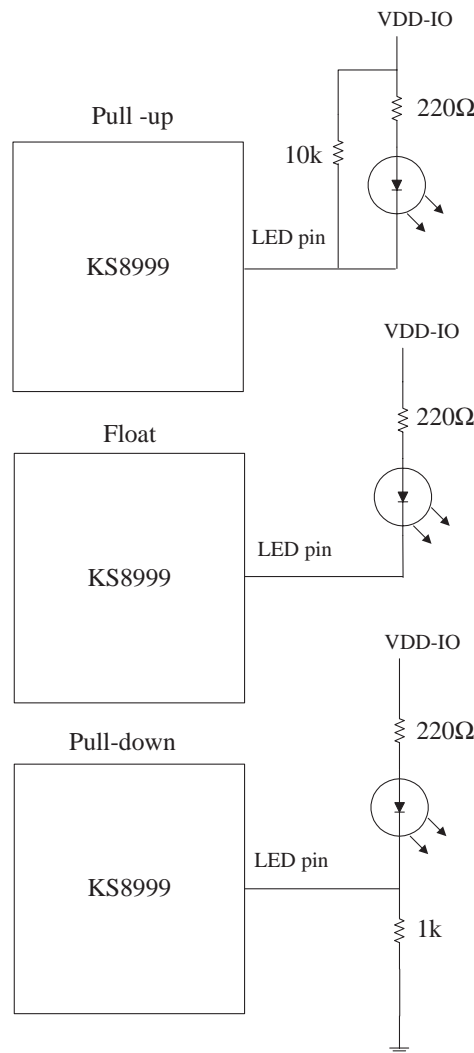
Figure 18. KS8999 MAC Mode Transmit Timing

Symbol	Parameter	Min	Typ	Max	Units
$t_{CYC}$	Clock Cycle (100BaseT)		40		ns
$t_{CYC}$	Clock Cycle (10BaseT)		400		ns
$t_{OV}$	Output Valid	7	11	16	ns

Table 12. KS8999 MAC Mode Transmit Timing Parameters

## Reference Circuits

See “I/O Description” section for pull-up/pull-down and float information.

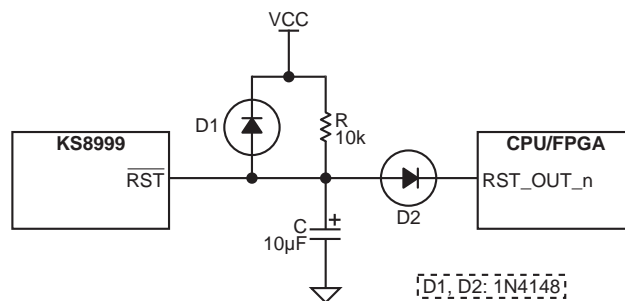


Reference circuits for unmanaged programming through LED ports  
 Note: For brighter LED operation use VDD-IO = 3.3V

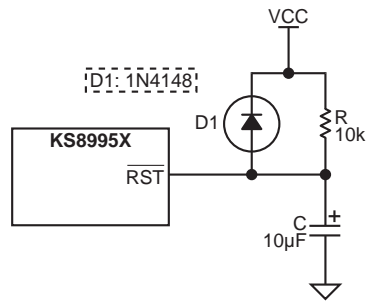
**Figure 19. Unmanaged Programming Circuit**

## Reset Reference Circuit

Micrel recommends the following discrete reset circuit as shown in Figure 20 when powering up the KS8999 device. For the application where the reset circuit signal comes from another device (e.g., CPU, FPGA, etc), we recommend the reset circuit as shown in Figure 21.



**Figure 20. Recommended Reset Circuit.**



**Figure 21. Recommended Circuit for Interfacing with CPU/FPGA Reset**

At power-on-reset, R, C, and D1 provide the necessary ramp rise time to reset the KS8999 device. The reset out from CPU/FPGA provides warm reset after power up. It is also recommended to power up the VDD core voltage earlier than VDDIO voltage. At worst case, the both VDD core and VDDIO voltages should come up at the same time.



## 4B/5B Coding

In 100BaseTX and 100BaseFX the data and frame control are encoded in the transmitter (and decoded in the receiver) using a 4B/5B code. The extra code space is required to encode extra control (frame delineation) points. It is also used to reduce run length as well as supply sufficient transitions for clock recovery. The table below provides the translation for the 4B/5B coding.

Code Type	4B Code	5B Code	Value
Data	0000	11110	Data value 0
	0001	01001	Data value 1
	0010	10100	Data value 2
	0011	10101	Data value 3
	0100	01010	Data value 4
	0101	01011	Data value 5
	0110	01110	Data value 6
	0111	01111	Data value 7
	1000	10010	Data value 8
	1001	10011	Data value 9
	1010	10110	Data value A
	1011	10111	Data value B
	1100	11010	Data value C
	1101	11011	Data value D
	1110	11100	Data value E
	1111	11101	Data value F
Control	Not defined	11111	Idle
	0101	11000	Start delimiter part 1
	0101	10001	Start delimiter part 2
	Not defined	01101	End delimiter part 1
	Not defined	00111	End delimiter part 2
	Not defined	00100	Transmit error
Invalid	Not defined	00000	Invalid code
	Not defined	00001	Invalid code
	Not defined	00010	Invalid code
	Not defined	00011	Invalid code
	Not defined	00101	Invalid code
	Not defined	00110	Invalid code
	Not defined	01000	Invalid code
	Not defined	01100	Invalid code
	Not defined	10000	Invalid code
	Not defined	11001	Invalid code

**Table 13. 4B/5B Coding**

## MLT3 Coding

For 100BaseTX operation the NRZI (Non-Return to Zero Invert on ones) signal is line coded as MLT3. The net result of using MLT3 is to reduce the EMI (Electro Magnetic Interference) of the signal over twisted pair media. In NRZI coding, the level changes from high to low or low to high for every "1" bit. For a "0" bit there is no transition. MLT3 line coding transitions through three distinct levels. For every transition of the NRZI signal the MLT3 signal either increments or decrements depending on the current state of the signal. For instance if the MLT3 level is at its lowest point the next two NRZI transitions will change the MLT3 signal initially to the middle level followed by the highest level (second NRZI transition). On the next NRZI change, the MLT3 level will decrease to the middle level. On the following transition of the NRZI signal the MLT3 level will move to the lowest level where the cycle repeats. The diagram below describes the level changes. Note that in the actual 100BaseTX circuit there is a scrambling circuit and that scrambling is not shown in this diagram.

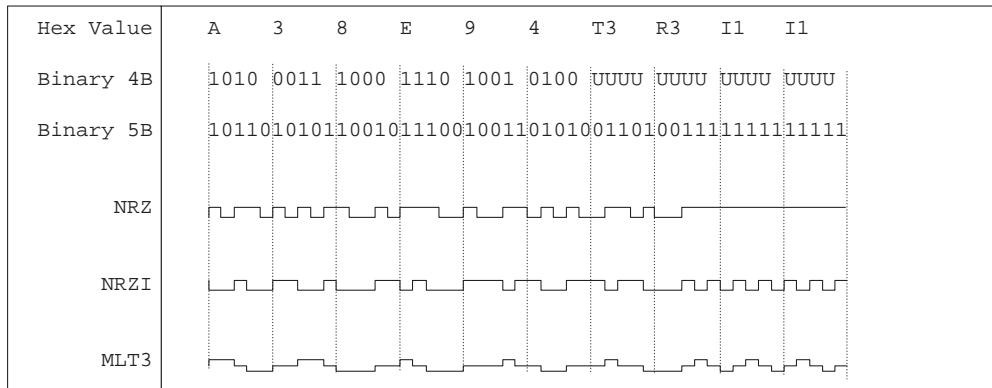


Figure 20. MLT3 coding

## MAC Frame

The MAC (Media Access Control) fields are described in the table below.

Field	Octect Length	Description
Preamble/SFD	8	Preamble and Start of Frame Delimiter
DA	6	48-bit Destination MAC Address
SA	6	48-bit Source MAC Address
Length	2	Frame Length
Protocol/Data	46 to 1500	Higher Layer Protocol and Frame Data
Frame CRC	4	32-bit Cyclical Redundancy Check
ESD	1	End of Stream Delimiter
Idle	Variable	Inter Frame Idles

Table 14. MAC Frame

## Selection of Isolation Transformer<sup>(Note 1)</sup>

One simple 1:1 isolation transformer is needed at the line interface. An isolation transformer with integrated common-mode choke is recommended for exceeding FCC requirements. The following table gives recommended transformer characteristics.

Characteristics Name	Value	Test Condition
Turns Ratio	1 CT : 1 CT	
Open-Circuit Inductance (min.)	350 $\mu$ H	100mV, 100 KHz, 8mA
Leakage Inductance (max.)	0.4 $\mu$ H	1MHz (min.)
Inter-Winding Capacitance (max.)	12pF	
D.C. Resistance (max.)	0.9 $\Omega$	
Insertion Loss (max.)	1.0dB	0MHz to 65MHz
HIPOT (min.)	1500Vrms	

**Note 1.** The IEEE 802.3u standard for 100BaseTX assumes a transformer loss of 0.5dB. For the transmit line transformer, insertion loss of up to 1.3dB can be compensated by increasing the line drive current by means of reducing the ISET resistor value.

## Selection of Reference Oscillator/Crystal

An oscillator or crystal with the following typical characteristics is recommended.

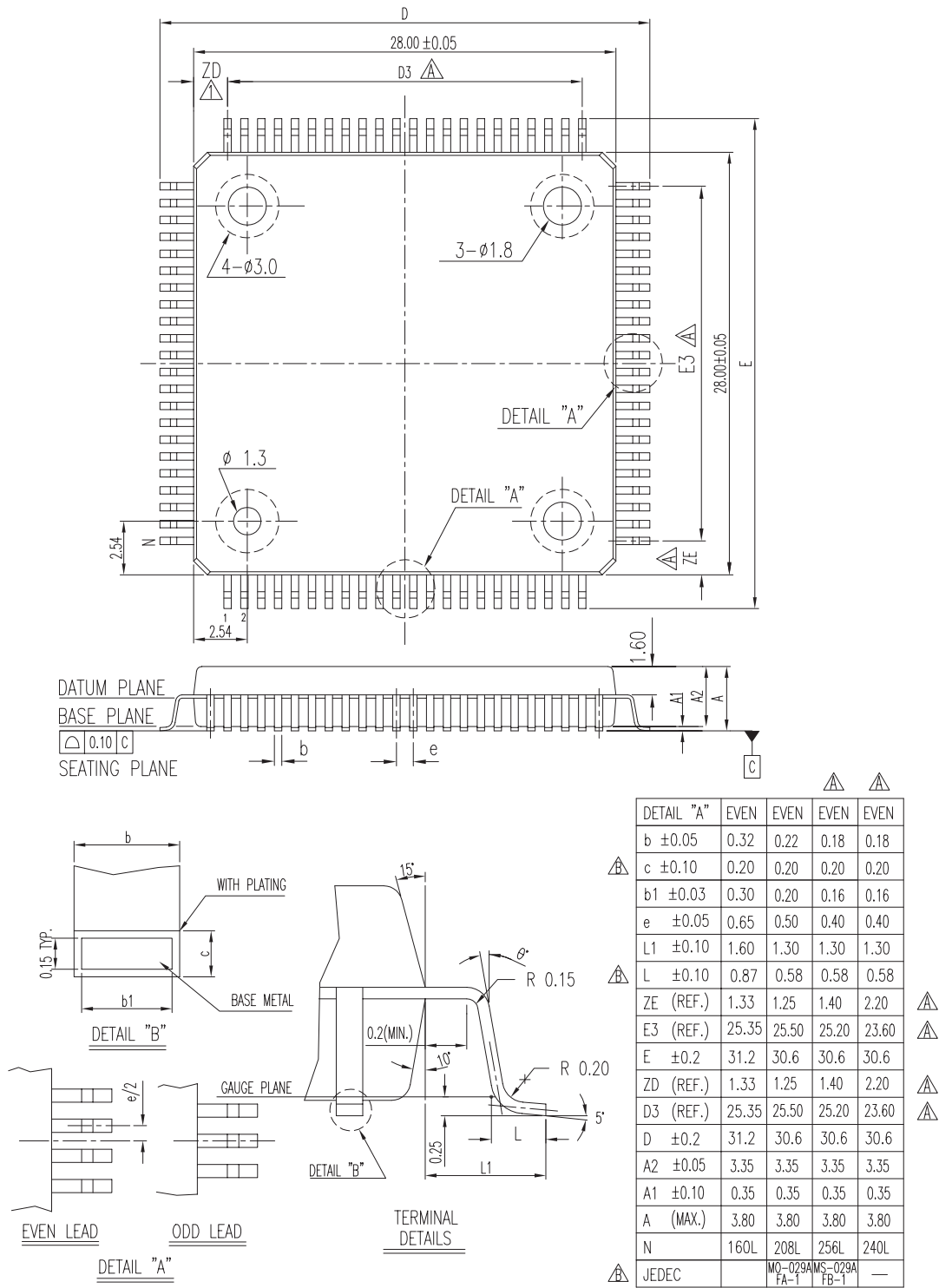
Characteristics Name	Value	Test Condition
Frequency	25.00000	MHz
Maximum Frequency Tolerance	$\pm$ 50	ppm
Maximum Jitter	150	ps(pk-pk)

The following transformer vendors provide compatible magnetic parts for Micrel's device:

4-Port Integrated Part		Auto MDIX	Number of Port	Single Port Part		Auto MDIX	Number of Port
Vendor	Part			Vendor	Part		
Pulse	H1164	Yes	4	Pulse	H1102	Yes	1
Bel Fuse	558-5999-Q9	Yes	4	Bel Fuse	S558-5999-U7	Yes	1
YCL	PH406466	Yes	4	YCL	PT163020	Yes	1
Transpower	HB826-2	Yes	4	Transpower	HB726	Yes	1
Delta	LF8731	Yes	4	Delta	LF8505	Yes	1

**Table 15. Qualified Magnetics Vendor Lists**

Package Information



208-Pin PQFP (PQ)

MICREL, INC. 2180 FORTUNE DRIVE SAN JOSE, CA 95131 USA

TEL + 1 (408) 944-0800 FAX + 1 (408) 474-1000 WEB <http://www.micrel.com>

The information furnished by Micrel in this datasheet is believed to be accurate and reliable. However, no responsibility is assumed by Micrel for its use. Micrel reserves the right to change circuitry and specifications at any time without notification to the customer.

Micrel Products are not designed or authorized for use as components in life support appliances, devices or systems where malfunction of a product can reasonably be expected to result in personal injury. Life support devices or systems are devices or systems that (a) are intended for surgical implant into the body or (b) support or sustain life, and whose failure to perform can be reasonably expected to result in a significant injury to the user. A Purchaser's use or sale of Micrel Products for use in life support appliances, devices or systems is at Purchaser's own risk and Purchaser agrees to fully indemnify Micrel for any damages resulting from such use or sale.

© 2005 Micrel, Incorporated.

Компания «Life Electronics» занимается поставками электронных компонентов импортного и отечественного производства от производителей и со складов крупных дистрибьюторов Европы, Америки и Азии.

С конца 2013 года компания активно расширяет линейку поставок компонентов по направлению коаксиальный кабель, кварцевые генераторы и конденсаторы (керамические, пленочные, электролитические), за счёт заключения дистрибьюторских договоров

Мы предлагаем:

- Конкуренеспособные цены и скидки постоянным клиентам.
- Специальные условия для постоянных клиентов.
- Подбор аналогов.
- Поставку компонентов в любых объемах, удовлетворяющих вашим потребностям.
- Приемлемые сроки поставки, возможна ускоренная поставка.
- Доставку товара в любую точку России и стран СНГ.
- Комплексную поставку.
- Работу по проектам и поставку образцов.
- Формирование склада под заказчика.
- Сертификаты соответствия на поставляемую продукцию (по желанию клиента).
- Тестирование поставляемой продукции.
- Поставку компонентов, требующих военную и космическую приемку.
- Входной контроль качества.
- Наличие сертификата ISO.

В составе нашей компании организован Конструкторский отдел, призванный помогать разработчикам, и инженерам.

Конструкторский отдел помогает осуществить:

- Регистрацию проекта у производителя компонентов.
- Техническую поддержку проекта.
- Защиту от снятия компонента с производства.
- Оценку стоимости проекта по компонентам.
- Изготовление тестовой платы монтаж и пусконаладочные работы.



Тел: +7 (812) 336 43 04 (многоканальный)

Email: [org@lifeelectronics.ru](mailto:org@lifeelectronics.ru)