

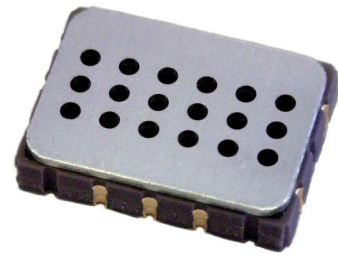

The MiCS-4514 is a compact MOS sensor with two fully independent sensing elements on one package.

The MiCS-4514 is a robust MEMS sensor for the detection of pollution from automobile exhausts.



## Features

- Smallest footprint for compact designs (5 x 7 x 1.55 mm)
- Robust MEMS sensor for harsh environments
- High-volume manufacturing for low-cost applications
- Short lead-times

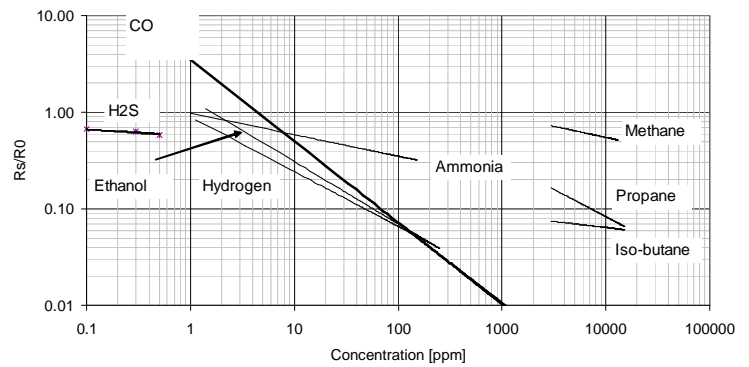

RED sensor, continuous power ON, 25°C, 50% RH

## Detectable gases

- |                    |                                  |              |
|--------------------|----------------------------------|--------------|
| • Carbon monoxide  | CO                               | 1 – 1000ppm  |
| • Nitrogen dioxide | NO <sub>2</sub>                  | 0.05 – 10ppm |
| • Ethanol          | C <sub>2</sub> H <sub>5</sub> OH | 10 – 500ppm  |
| • Hydrogen         | H <sub>2</sub>                   | 1 – 1000ppm  |
| • Ammonia          | NH <sub>3</sub>                  | 1 – 500ppm   |
| • Methane          | CH <sub>4</sub>                  | >1000ppm     |

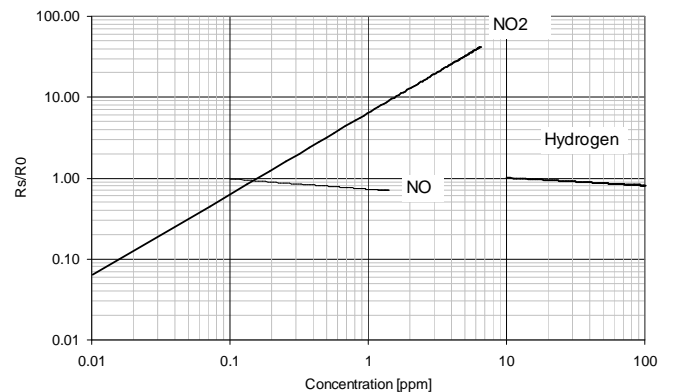

OX sensor, continuous power ON, 25°C, 50% RH

For more information please contact:

[info.em@sgxsensortech.com](mailto:info.em@sgxsensortech.com)

SGX Sensortech, Courtils 1  
CH-2035 Corcelles-Cormondrèche  
Switzerland

[www.sgxsensortech.com](http://www.sgxsensortech.com)

## Performance RED sensor

Characteristic RED sensor	Symbol	Typ	Min	Max	Unit
Sensing resistance in air (see note 1)	$R_0$	-	100	1500	k $\Omega$
Typical CO detection range	FS		1	1000	ppm
Sensitivity factor (see note 2)	$S_{60}$	-	1.2	50	-

## Performance OX sensor

Characteristic OX sensor	Symbol	Typ	Min	Max	Unit
Sensing resistance in air (see note 1)	$R_0$	-	0.8	20	k $\Omega$
Typical NO <sub>2</sub> detection range	FS		0.05	10	ppm
Sensitivity factor (see note 3)	$S_R$	-	2	-	-

### Notes:

1. Sensing resistance in air  $R_0$  is measured under controlled ambient conditions, i.e. synthetic air at  $23 \pm 5^\circ\text{C}$  and  $50 \pm 10\%$  RH for RED sensor and synthetic air at  $23 \pm 5^\circ\text{C}$  and  $\leq 5\%$  RH for OX sensor. Sampling test.
2. Sensitivity factor is defined as  $R_s$  in air divided by  $R_s$  at 60 ppm CO. Test conditions are  $23 \pm 5^\circ\text{C}$  and  $50 \pm 10\%$  RH. Indicative values only. Sampling test.
3. Sensitivity factor is defined as  $R_s$  at 0.25 ppm NO<sub>2</sub>, divided by  $R_s$  in air. Test conditions are  $23 \pm 5^\circ\text{C}$  and  $\leq 5\%$  RH. Indicative values only. Sampling test.

### IMPORTANT PRECAUTIONS:

Read the following instructions carefully before using the MiCS-4514 described here to avoid erroneous readings and to prevent the device from permanent damage.

- The sensor must be reflow soldered in a neutral atmosphere, without soldering flux vapours.
- The sensor must not be exposed to high concentrations of organic solvents, silicone vapours or cigarette-smoke in order to avoid poisoning the sensitive layer.
- Heater voltage above the specified maximum rating will destroy the sensor due to overheating.
- This sensor is to be placed in a filtered package that protects it against water and dust projections.
- SGX sensortech strongly recommends using ESD protection equipment to handle the sensor.

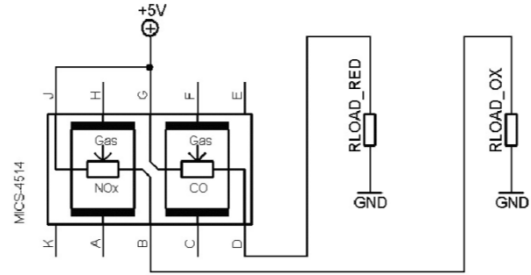
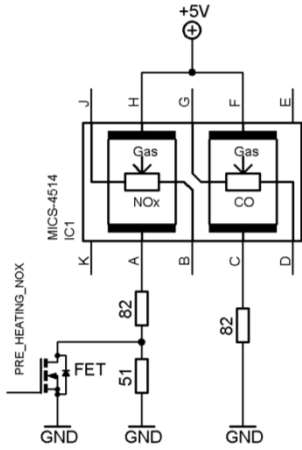

MiCS-4514 with recommended supply circuit (top view)

RDRED is a 82 Ω and RDOX is a 133Ω. These resistors are necessary to obtain the right temperatures on the two independant heaters while using a single 5V power supply. The resulting voltages are typically VHRED = 2.4V and VHGX= 1.7V.

MiCS-4514 with measurement circuit (top view)

The two voltages measured on the load resistors are directly linked to the resistances of the RED and OX sensors respectively. RLOAD must be 820 Ω at the lowest in order not to damage the sensitive layer.

Parameter RED sensor/OX sensor	Symbol	Typ	Min	Max	Unit
Heating power	$P_H$	76/43	71/30	81/50	mW
Heating voltage	$V_H$	2.4/1.7	-	-	V
Heating current	$I_H$	32/26	-	-	mA
Heating resistance at nominal power	$R_H$	74/66	66/59	82/73	Ω

Rating	Symbol	Value / Range	Unit
Maximum heater power dissipation	$P_H$	88 (RED sensor)/50 (OX sensor)	mW
Maximum sensitive layer power dissipation	$P_s$	8	mW
Voltage supplyHeating current	$V_{supply}$	4.9 – 5.1	V
Relative humidity range	RH	5 – 95	%RH
Ambient operating temperature	$T_{amb}$	-30 – 85	°C
Storage temperature range	$T_{sto}$	-40 – 120	°C
Storage humidity range	RHsto	5 - 95	%RH

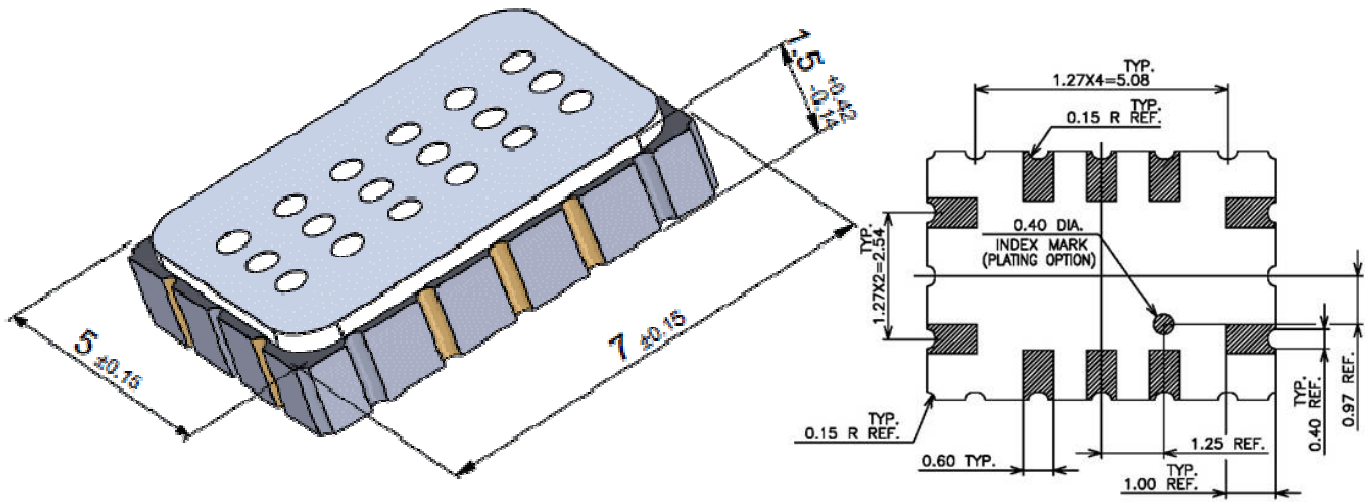

## Package outline dimensions

The package is compatible with SMD assembly process.

Pin	Connection
A	Rh1 OX
B	Rs1 OX
C	Rh1 RED
D	Rs1 RED
E	NC
F	Rh2 RED
G	Rs2 RED
H	Rh2 OX
J	Rs2 OX
K	NC

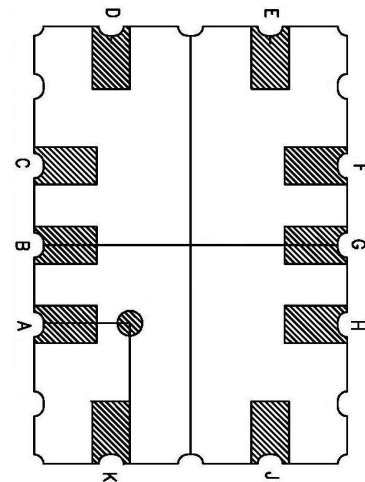

MiCS-4514 configuration (bottom view)

## Sensor configuration

The silicon gas sensor structure consists of an accurately micro machined diaphragm with an embedded heating resistor and the sensing layer on top.

The MiCS-4514 includes two sensor chips with independent heaters and sensitive layers. One sensor chip detects oxidising gases (OX) and the other sensor detects reducing gases (RED). The internal connections are shown above.

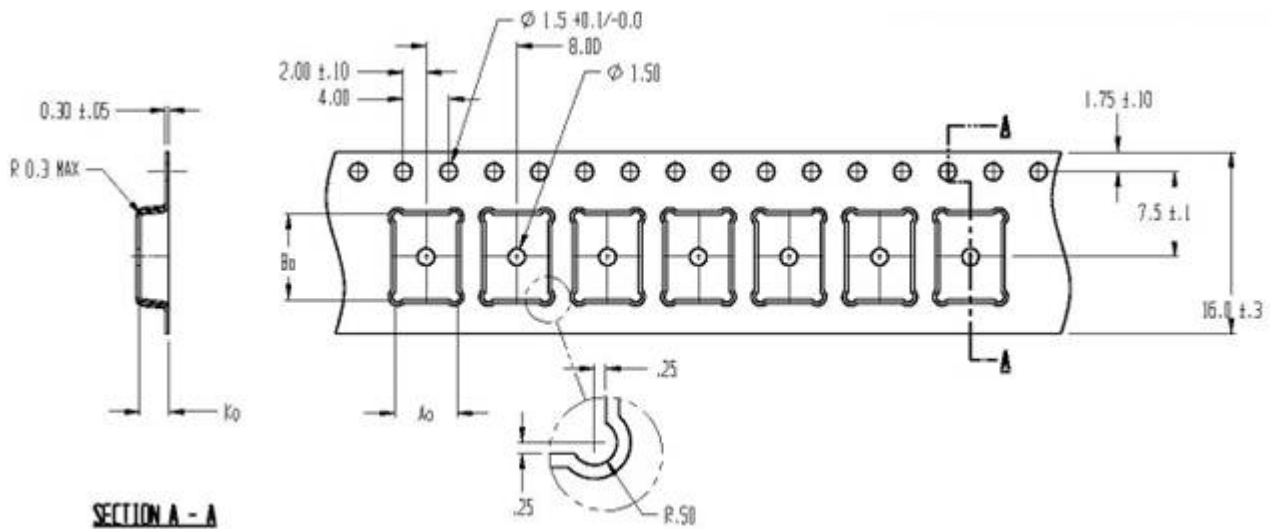

## Packaging

The sensors are packaged in a tape and reel for expedition.

The sensors are placed in a carrier type. The dimensions of the cavity are 5.5 x 7.5 x 2.55 mm (the tolerance is +/- 0.2 mm).

The outside dimension of the reel is either 178 +/- mm (for a maximum of 700 sensors ) or 330 + 0.25 / -4 mm (for a maximum of 2000 sensors).

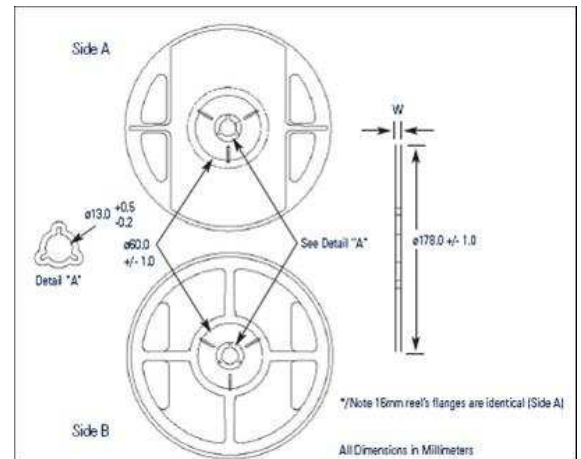

## For more information please contact:

[info.em@sgxsensortech.com](mailto:info.em@sgxsensortech.com)

SGX Sensortech, Courtils 1  
CH-2035 Corcelles-Cormondrèche  
Switzerland

[www.sgxsensortech.com](http://www.sgxsensortech.com)

Whilst SGX sensortech has taken care to ensure the accuracy of the information contained herein it accepts no responsibility for the consequences of any use thereof and also reserves the right to change the specification of goods without notice. SGX sensortech accepts no liability beyond the set out in its standard conditions of sale in respect of infringement of third party patents arising from the use of tubes or other devices in accordance with information contained herein.

Компания «Life Electronics» занимается поставками электронных компонентов импортного и отечественного производства от производителей и со складов крупных дистрибьюторов Европы, Америки и Азии.

С конца 2013 года компания активно расширяет линейку поставок компонентов по направлению коаксиальный кабель, кварцевые генераторы и конденсаторы (керамические, пленочные, электролитические), за счёт заключения дистрибьюторских договоров

Мы предлагаем:

- Конкурентоспособные цены и скидки постоянным клиентам.
- Специальные условия для постоянных клиентов.
- Подбор аналогов.
- Поставку компонентов в любых объемах, удовлетворяющих вашим потребностям.
- Приемлемые сроки поставки, возможна ускоренная поставка.
- Доставку товара в любую точку России и стран СНГ.
- Комплексную поставку.
- Работу по проектам и поставку образцов.
- Формирование склада под заказчика.
- Сертификаты соответствия на поставляемую продукцию (по желанию клиента).
- Тестирование поставляемой продукции.
- Поставку компонентов, требующих военную и космическую приемку.
- Входной контроль качества.
- Наличие сертификата ISO.

В составе нашей компании организован Конструкторский отдел, призванный помогать разработчикам, и инженерам.

Конструкторский отдел помогает осуществить:

- Регистрацию проекта у производителя компонентов.
- Техническую поддержку проекта.
- Защиту от снятия компонента с производства.
- Оценку стоимости проекта по компонентам.
- Изготовление тестовой платы монтаж и пусконаладочные работы.



Тел: +7 (812) 336 43 04 (многоканальный)  
Email: [org@lifeelectronics.ru](mailto:org@lifeelectronics.ru)