

AD7859/AD7859L

FEATURES

Specified for V_{DD} of 3 V to 5.5 V
AD7859–200 kSPS; AD7859L–100 kSPS
System and Self-Calibration
Low Power

Normal Operation

AD7859: 15 mW ($V_{DD} = 3$ V)
AD7859L: 5.5 mW ($V_{DD} = 3$ V)

Using Automatic Power-Down After Conversion (25 μ W)

AD7859: 1.3 mW ($V_{DD} = 3$ V 10 kSPS)
AD7859L: 650 μ W ($V_{DD} = 3$ V 10 kSPS)

Flexible Parallel Interface:

16-Bit Parallel/8-Bit Parallel
44-Pin PQFP and PLCC Packages

APPLICATIONS

Battery-Powered Systems (Personal Digital Assistants,
Medical Instruments, Mobile Communications)
Pen Computers
Instrumentation and Control Systems
High Speed Modems

GENERAL DESCRIPTION

The AD7859/AD7859L are high speed, low power, 8-channel, 12-bit ADCs which operate from a single 3 V or 5 V power supply, the AD7859 being optimized for speed and the AD7859L for low power. The ADC contains self-calibration and system calibration options to ensure accurate operation over time and temperature and have a number of power-down options for low power applications.

The AD7859 is capable of 200 kHz throughput rate while the AD7859L is capable of 100 kHz throughput rate. The input track-and-hold acquires a signal in 500 ns and features a pseudo-differential sampling scheme. The AD7859 and AD7859L input voltage range is 0 to V_{REF} (unipolar) and $-V_{REF}/2$ to $+V_{REF}/2$ about $V_{REF}/2$ (bipolar) with both straight binary and 2s complement output coding respectively. Input signal range is to the supply and the part is capable of converting full-power signals to 100 kHz.

CMOS construction ensures low power dissipation of typically 5.4 mW for normal operation and 3.6 μ W in power-down mode. The part is available in 44-pin, plastic quad flatpack package (PQFP) and plastic lead chip carrier (PLCC).

See page 28 for data sheet index.

REV. A

Information furnished by Analog Devices is believed to be accurate and reliable. However, no responsibility is assumed by Analog Devices for its use, nor for any infringements of patents or other rights of third parties which may result from its use. No license is granted by implication or otherwise under any patent or patent rights of Analog Devices.

FUNCTIONAL BLOCK DIAGRAM

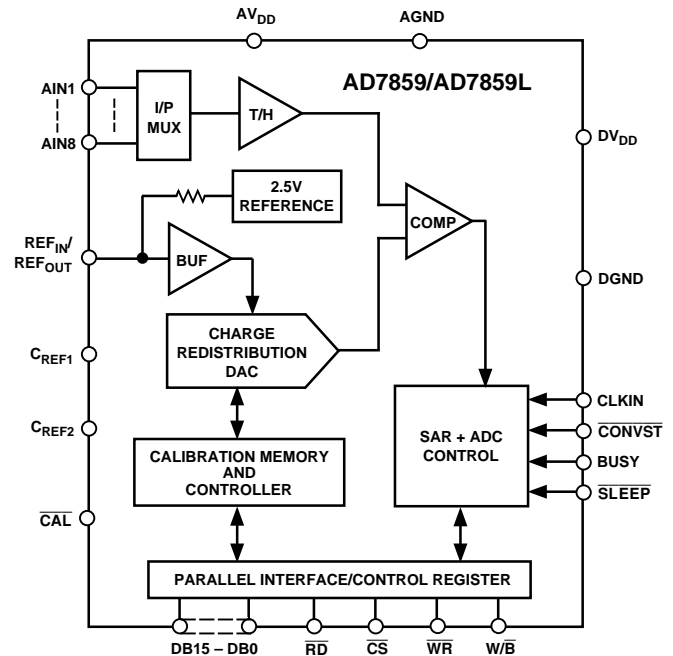

PRODUCT HIGHLIGHTS

1. Operation with either 3 V or 5 V power supplies.
2. Flexible power management options including automatic power-down after conversion.
3. By using the power management options a superior power performance at slower throughput rates can be achieved.
AD7859: 1 mW typ @ 10 kSPS
AD7859L: 1 mW typ @ 20 kSPS
4. Operates with reference voltages from 1.2 V to the supply.
5. Analog input ranges from 0 V to V_{DD} .
6. Self and system calibration.
7. Versatile parallel I/O port.
8. Lower power version AD7859L.

AD7859/AD7859L—SPECIFICATIONS^{1, 2}

($A_{V_{DD}} = DV_{DD} = +3.0\text{ V to }+5.5\text{ V}$, $REF_{IN}/REF_{OUT} = 2.5\text{ V}$)

External Reference, $f_{CLKIN} = 4\text{ MHz}$ (for L Version: 1.8 MHz ($0^{\circ}\text{C to }+70^{\circ}\text{C}$) and 1 MHz ($-40^{\circ}\text{C to }+85^{\circ}\text{C}$)); $f_{SAMPLE} = 200\text{ kHz}$ (AD7859) 100 kHz (AD7859L); SLEEP = Logic High; $T_A = T_{MIN}$ to T_{MAX} , unless otherwise noted.) Specifications in () apply to the AD7859L.

Parameter	A Version ¹	B Version ¹	Units	Test Conditions/Comments
DYNAMIC PERFORMANCE				
Signal to Noise + Distortion Ratio ³ (SNR)	70	71	dB min	Typically SNR is 72 dB $V_{IN} = 10\text{ kHz Sine Wave}$, $f_{SAMPLE} = 200\text{ kHz}$ (for L Version: $f_{SAMPLE} = 100\text{ kHz @ }f_{CLKIN} = 2\text{ MHz}$)
Total Harmonic Distortion (THD)	-78	-78	dB max	$V_{IN} = 10\text{ kHz Sine Wave}$, $f_{SAMPLE} = 200\text{ kHz}$ (for L Version: $f_{SAMPLE} = 100\text{ kHz @ }f_{CLKIN} = 2\text{ MHz}$)
Peak Harmonic or Spurious Noise	-78	-78	dB max	$V_{IN} = 10\text{ kHz Sine Wave}$, $f_{SAMPLE} = 200\text{ kHz}$ (for L Version: $f_{SAMPLE} = 100\text{ kHz @ }f_{CLKIN} = 2\text{ MHz}$)
Intermodulation Distortion (IMD) Second Order Terms	-78	-78	dB typ	$f_a = 9.983\text{ kHz}$, $f_b = 10.05\text{ kHz}$, $f_{SAMPLE} = 200\text{ kHz}$ (for L Version: $f_{SAMPLE} = 100\text{ kHz @ }f_{CLKIN} = 2\text{ MHz}$)
Third Order Terms	-78	-78	dB typ	$f_a = 9.983\text{ kHz}$, $f_b = 10.05\text{ kHz}$, $f_{SAMPLE} = 200\text{ kHz}$ (for L Version: $f_{SAMPLE} = 100\text{ kHz @ }f_{CLKIN} = 2\text{ MHz}$)
Channel-to-Channel Isolation	-80	-80	dB typ	$V_{IN} = 25\text{ kHz}$
DC ACCURACY				
Resolution	12	12	Bits	5 V Reference $V_{DD} = 5\text{ V}$ Guaranteed No Missed Codes to 12 Bits
Integral Nonlinearity	± 1	± 0.5	LSB max	
Differential Nonlinearity	± 1	± 1	LSB max	
Unipolar Offset Error	± 5	± 5	LSB max	
	± 2	± 2	LSB typ	
Unipolar Offset Error Match	2(3)	2	LSB max	
Positive Full-Scale Error	± 5	± 5	LSB max	
	± 2	± 2	LSB typ	
Negative Full-Scale Error	± 2	± 2	LSB max	
Full-Scale Error Match	1	1	LSB max	
Bipolar Zero Error	± 1	± 1	LSB typ	
Bipolar Zero Error Match	2	2	LSB typ	
ANALOG INPUT				
Input Voltage Ranges	0 to V_{REF}	0 to V_{REF}	Volts	i.e., $A_{IN}(+) - A_{IN}(-) = 0$ to V_{REF} ; $A_{IN}(-)$ Can Be Biased Up But $A_{IN}(+)$ Cannot Go Below $A_{IN}(-)$ i.e., $A_{IN}(+) - A_{IN}(-) = -V_{REF}/2$ to $+V_{REF}/2$; $A_{IN}(-)$ Should Be Biased to $+V_{REF}/2$ and $A_{IN}(+)$ Can Go Below $A_{IN}(-)$ But Cannot Go Below 0 V
	$\pm V_{REF}/2$	$\pm V_{REF}/2$	Volts	
Leakage Current	± 1	± 1	$\mu\text{A max}$	
Input Capacitance	20	20	pF typ	
REFERENCE INPUT/OUTPUT				
REF_{IN} Input Voltage Range	$2.3/V_{DD}$	$2.3/V_{DD}$	V min/max	Functional from 1.2 V
Input Impedance	150	150	k Ω typ	
REF_{OUT} Output Voltage	$2.3/2.7$	$2.3/2.7$	V min/max	
REF_{OUT} Tempco	20	20	ppm/ $^{\circ}\text{C}$ typ	
LOGIC INPUTS				
Input High Voltage, V_{INH}	2.4	2.4	V min	$A_{V_{DD}} = DV_{DD} = 4.5\text{ V to }5.5\text{ V}$ $A_{V_{DD}} = DV_{DD} = 3.0\text{ V to }3.6\text{ V}$
$\overline{\text{CAL}}$ Pin	3	3	V min	
	2.4	2.4	V min	$A_{V_{DD}} = DV_{DD} = 4.5\text{ V to }5.5\text{ V}$ $A_{V_{DD}} = DV_{DD} = 3.0\text{ V to }3.6\text{ V}$
Input Low Voltage, V_{INL}	0.8	0.8	V max	
	0.6	0.6	V max	$A_{V_{DD}} = DV_{DD} = 4.5\text{ V to }5.5\text{ V}$ $A_{V_{DD}} = DV_{DD} = 3.0\text{ V to }3.6\text{ V}$
Input Current, I_{IN}	± 10	± 10	$\mu\text{A max}$	
Input Capacitance, C_{IN}^4	10	10	pF max	Typically 10 nA, $V_{IN} = 0\text{ V}$ or V_{DD}
LOGIC OUTPUTS				
Output High Voltage, V_{OH}	4	4	V min	$A_{V_{DD}} = DV_{DD} = 4.5\text{ V to }5.5\text{ V}$ $A_{V_{DD}} = DV_{DD} = 3.0\text{ V to }3.6\text{ V}$
	2.4	2.4	V min	
Output Low Voltage, V_{OL}	0.4	0.4	V max	$I_{SINK} = 1.6\text{ mA}$
Floating State Leakage Current	± 10	± 10	$\mu\text{A max}$	
Floating-State Output Capacitance ⁴	10	10	pF max	
Output Coding	Straight (Natural) Binary 2s Complement			Unipolar Input Range Bipolar Input Range

Parameter	A Version ¹	B Version ¹	Units	Test Conditions/Comments
CONVERSION RATE				$t_{\text{CLKIN}} \times 18$
Conversion Time	4.5 (10)	4.5	μs max	(L Versions Only, 0°C to +70°C, 1.8 MHz CLKIN)
Track/Hold Acquisition Time	0.5 (1)	0.5	μs min	(L Versions Only, -40°C to +85°C, 1.8 MHz CLKIN)
POWER REQUIREMENTS				
$A_{V_{DD}}, DV_{DD}$	+3.0/+5.5	+3.0/+5.5	V min/max	
I_{DD}				
Normal Mode ⁵	5.5 (1.95)	5.5	mA max	$A_{V_{DD}} = DV_{DD} = 4.5$ V to 5.5 V. Typically 4.5 mA
Sleep Mode ⁶	5.5 (1.95)	5.5	mA max	$A_{V_{DD}} = DV_{DD} = 3.0$ V to 3.6 V. Typically 4.0 mA
With External Clock On	10	10	μA typ	Full Power-Down. Power Management Bits in Control Register Set as PMGT1 = 1, PMGT0 = 0.
	400	400	μA typ	Partial Power-Down. Power Management Bits in Control Register Set as PMGT1 = 1, PMGT0 = 1.
With External Clock Off	5	5	μA max	Typically 1 μA . Full Power-Down. Power Management Bits in Control Register Set as PMGT1 = 1, PMGT0 = 0.
	200	200	μA typ	Partial Power-Down. Power Management Bits in Control Register Set as PMGT1 = 1, PMGT0 = 1.
Normal Mode Power Dissipation	30 (10)	30 (10)	mW max	$V_{DD} = 5.5$ V: Typically 25 mW (8); $\overline{\text{SLEEP}} = V_{DD}$
	20 (6.5)	20 (6.5)	mW max	$V_{DD} = 3.6$ V: Typically 15 mW (5.4); $\overline{\text{SLEEP}} = V_{DD}$
Sleep Mode Power Dissipation				
With External Clock On	55	55	μW typ	$V_{DD} = 5.5$ V; $\overline{\text{SLEEP}} = 0$ V
	36	36	μW typ	$V_{DD} = 3.6$ V; $\overline{\text{SLEEP}} = 0$ V
With External Clock Off	27.5	27.5	μW max	$V_{DD} = 5.5$ V: Typically 5.5 μW ; $\overline{\text{SLEEP}} = 0$ V
	18	18	μW max	$V_{DD} = 3.6$ V: Typically 3.6 μW ; $\overline{\text{SLEEP}} = 0$ V
SYSTEM CALIBRATION				
Offset Calibration Span ⁷	$+0.05 \times V_{\text{REF}} / -0.05 \times V_{\text{REF}}$		V max/min	Allowable Offset Voltage Span for Calibration
Gain Calibration Span ⁷	$+1.025 \times V_{\text{REF}} / -0.975 \times V_{\text{REF}}$		V max/min	Allowable Full-Scale Voltage Span for Calibration

NOTES

¹Temperature range as follows: A, B Versions, -40°C to +85°C.

²Specifications apply after calibration.

³SNR calculation includes distortion and noise components.

⁴Not production tested, guaranteed by characterization at initial product release.

⁵All digital inputs @ DGND except for $\overline{\text{CONVST}}$, $\overline{\text{SLEEP}}$, $\overline{\text{CAL}}$, and $\overline{\text{SYNC}}$ @ DV_{DD} . No load on the digital outputs. Analog inputs @ AGND.

⁶CLKIN @ DGND when external clock off. All digital inputs @ DGND except for $\overline{\text{CONVST}}$, $\overline{\text{SLEEP}}$, $\overline{\text{CAL}}$, and $\overline{\text{SYNC}}$ @ DV_{DD} . No load on the digital outputs. Analog inputs @ AGND.

⁷The offset and gain calibration spans are defined as the range of offset and gain errors that the AD7859/AD7859L can calibrate. Note also that these are voltage spans and are not absolute voltages (i.e., the allowable system offset voltage presented at AIN(+) for the system offset error to be adjusted out will be $\text{AIN}(-) \pm 0.05 \times V_{\text{REF}}$, and the allowable system full-scale voltage applied between AIN(+) and AIN(-) for the system full-scale voltage error to be adjusted out will be $V_{\text{REF}} \pm 0.025 \times V_{\text{REF}}$. This is explained in more detail in the calibration section of the data sheet.

Specifications subject to change without notice.

AD7859/AD7859L

TIMING SPECIFICATIONS¹ ($V_{DD} = DV_{DD} = +3.0\text{ V to }+5.5\text{ V}$; $f_{CLKIN} = 4\text{ MHz for AD7859 and }1.8\text{ MHz for AD7859L}$; $T_A = T_{MIN}\text{ to }T_{MAX}$, unless otherwise noted)

Parameter	Limit at T_{MIN} , T_{MAX} (A, B Versions)		Units	Description
	5 V	3 V		
f_{CLKIN} ²	500 4	500 4	kHz min MHz max	Master Clock Frequency
t_1 ³	1.8	1.8	MHz max	L Version
t_2	100	100	ns min	\overline{CONVST} Pulse Width
$t_{CONVERT}$	50	90	ns max	\overline{CONVST} to $BUSY \uparrow$ Propagation Delay
	4.5	4.5	$\mu\text{s max}$	Conversion Time = $18 t_{CLKIN}$
	10	10	$\mu\text{s max}$	L Version 1.8 MHz CLKIN. Conversion Time = $18 t_{CLKIN}$
t_3	15	15	ns min	$HBEN$ to \overline{RD} Setup Time
t_4	5	5	ns min	$HBEN$ to \overline{RD} Hold Time
t_5	0	0	ns min	\overline{CS} to \overline{RD} Setup Time
t_6	0	0	ns min	\overline{CS} to \overline{RD} Hold Time
t_7	55	55	ns min	\overline{RD} Pulse Width
t_8 ⁴	50	50	ns max	Data Access Time After \overline{RD}
t_9 ⁵	5	5	ns min	Bus Relinquish Time After \overline{RD}
	40	40	ns max	Bus Relinquish Time After \overline{RD}
t_{10}	60	70	ns min	Minimum Time Between Reads
t_{11}	0	0	ns min	$HBEN$ to \overline{WR} Setup Time
t_{12}	5	5	ns max	$HBEN$ to \overline{WR} Hold Time
t_{13}	0	0	ns min	\overline{CS} to \overline{WR} Setup Time
t_{14}	0	0	ns max	\overline{CS} to \overline{WR} Hold Time
t_{15}	55	70	ns min	\overline{WR} Pulse Width
t_{16}	10	10	ns min	Data Setup Time Before \overline{WR}
t_{17}	5	5	ns min	Data Hold Time After \overline{WR}
t_{18} ⁴	$1/2 t_{CLKIN}$	$1/2 t_{CLKIN}$	ns min	New Data Valid Before Falling Edge of $BUSY$
t_{19}	$2.5 t_{CLKIN}$	$2.5 t_{CLKIN}$	ns max	$CS \uparrow$ to $BUSY \uparrow$ in Calibration Sequence
t_{CAL} ⁶	31.25	31.25	ms typ	Full Self-Calibration Time, Master Clock Dependent ($125013 t_{CLKIN}$)
t_{CAL1} ⁶	27.78	27.78	ms typ	Internal DAC Plus System Full-Scale Cal Time, Master Clock Dependent ($111124 t_{CLKIN}$)
t_{CAL2} ⁶	3.47	3.47	ms typ	System Offset Calibration Time, Master Clock Dependent ($13889 t_{CLKIN}$)

NOTES

¹Sample tested at +25°C to ensure compliance. All input signals are specified with $t_r = t_f = 5\text{ ns}$ (10% to 90% of V_{DD}) and timed from a voltage level of 1.6 V.

²Mark/Space ratio for the master clock input is 40/60 to 60/40.

³The \overline{CONVST} pulse width will here only apply for normal operation. When the part is in power-down mode, a different \overline{CONVST} pulse width will apply (see Power-Down section).

⁴Measured with the load circuit of Figure 1 and defined as the time required for the output to cross 0.8 V or 2.4 V.

⁵ t_9 is derived from the measured time taken by the data outputs to change 0.5 V when loaded with the circuit of Figure 1. The measured number is then extrapolated back to remove the effects of charging or discharging the 50 pF capacitor. This means that the time, t_9 , quoted in the timing characteristics is the true bus relinquish time of the part and is independent of the bus loading.

⁶The typical time specified for the calibration times is for a master clock of 4 MHz. For the L version the calibration times will be longer than those quoted here due to the 1.8 MHz master clock.

Specifications subject to change without notice.

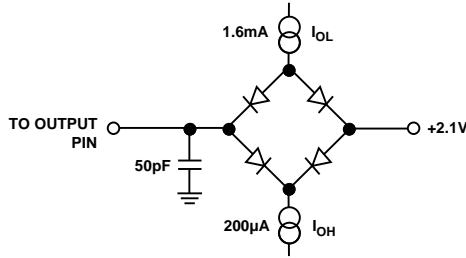

Figure 1. Load Circuit for Digital Output Timing Specifications

ORDERING GUIDE

Model	Linearity Error (LSB) ¹	Power Dissipation (mW)	Package Option ²
AD7859AP	±1	15	P-44A
AD7859AS	±1	15	S-44
AD7859BS	±1/2	15	S-44
AD7859LAS ³	±1	5.5	S-44
EVAL-AD7859CB ⁴			
EVAL-CONTROL BOARD ⁵			

NOTES

¹Linearity error refers to the integral linearity error.

²P = PLCC; S = PQFP.

³L signifies the low power version.

⁴This can be used as a stand-alone evaluation board or in conjunction with the EVAL-CONTROL BOARD for evaluation/demonstration purposes.

⁵This board is a complete unit allowing a PC to control and communicate with all Analog Devices, Inc. evaluation boards ending in the CB designators.

For more information on Analog Devices products and evaluation boards, visit our World Wide Web home page at <http://www.analog.com>.

ABSOLUTE MAXIMUM RATINGS¹

(T_A = +25°C unless otherwise noted)

AV _{DD} to AGND	−0.3 V to +7 V
DV _{DD} to DGND	−0.3 V to +7 V
AV _{DD} to DV _{DD}	−0.3 V to +0.3 V
Analog Input Voltage to AGND	−0.3 V to AV _{DD} + 0.3 V
Digital Input Voltage to DGND	−0.3 V to DV _{DD} + 0.3 V
Digital Output Voltage to DGND	−0.3 V to DV _{DD} + 0.3 V
REF _{IN} /REF _{OUT} to AGND	−0.3 V to AV _{DD} + 0.3 V
Input Current to Any Pin Except Supplies ²	±10 mA
Operating Temperature Range	
Commercial (A, B Versions)	−40°C to +85°C
Storage Temperature Range	−65°C to +150°C
Junction Temperature	+150°C
PQFP Package, Power Dissipation	450 mW
θ _{JA} Thermal Impedance	95°C/W
Lead Temperature, Soldering	
Vapor Phase (60 sec)	+215°C
Infrared (15 sec)	+220°C
PLCC Package, Power Dissipation	500 mW
θ _{JA} Thermal Impedance	55°C/W
Lead Temperature, Soldering	
Vapor Phase (60 sec)	+215°C
Infrared (15 sec)	+220°C
ESD	>1500 kV

NOTES

¹Stresses above those listed under “Absolute Maximum Ratings” may cause permanent damage to the device. This is a stress rating only and functional operation of the device at these or any other conditions above those listed in the operational sections of this specification is not implied. Exposure to absolute maximum rating conditions for extended periods may affect device reliability.

²Transient currents of up to 100 mA will not cause SCR latchup.

PINOUT FOR PLCC

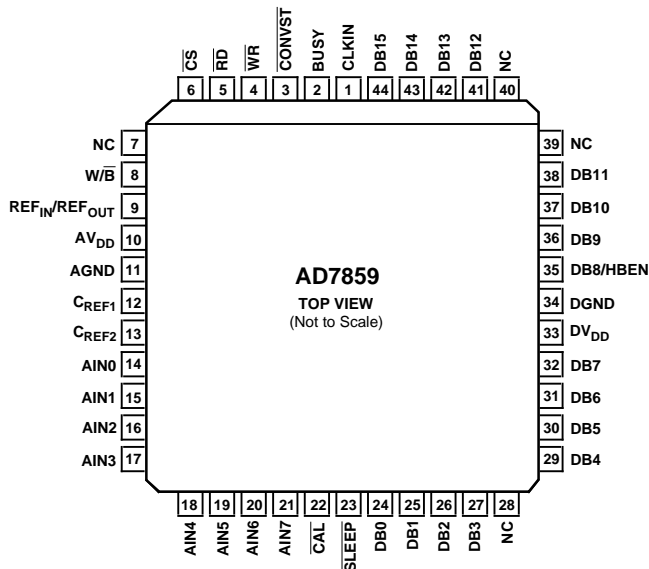

PINOUT FOR PQFP

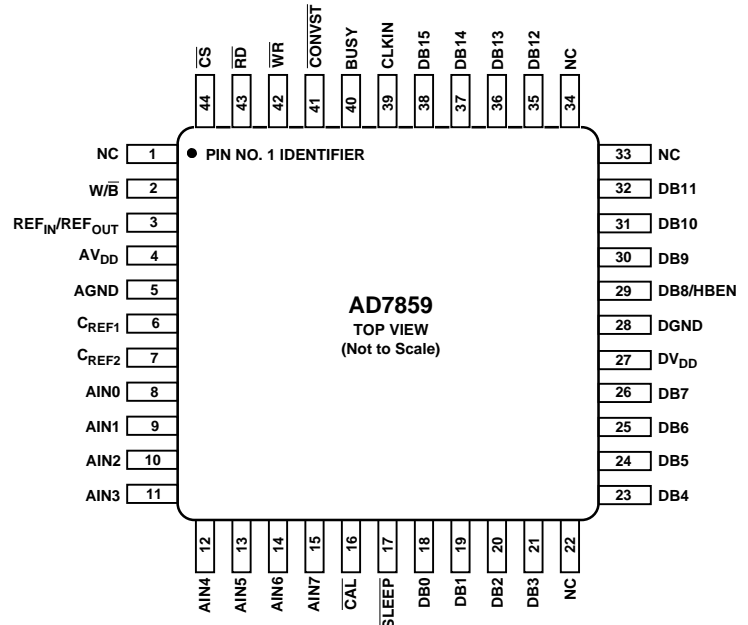

AD7859/AD7859L

TERMINOLOGY

Integral Nonlinearity

This is the maximum deviation from a straight line passing through the endpoints of the ADC transfer function. The endpoints of the transfer function are zero scale, a point 1/2 LSB below the first code transition, and full scale, a point 1/2 LSB above the last code transition.

Differential Nonlinearity

This is the difference between the measured and the ideal 1 LSB change between any two adjacent codes in the ADC.

Unipolar Offset Error

This is the deviation of the first code transition (00 . . . 000 to 00 . . . 001) from the ideal AIN(+) voltage (AIN(-) + 1/2 LSB) when operating in the unipolar mode.

Positive Full-Scale Error

This applies to the unipolar and bipolar modes and is the deviation of the last code transition from the ideal AIN(+) voltage (AIN(-) + Full Scale - 1.5 LSB) after the offset error has been adjusted out.

Negative Full-Scale Error

This applies to the bipolar mode only and is the deviation of the first code transition (10 . . . 000 to 10 . . . 001) from the ideal AIN(+) voltage (AIN(-) - $V_{REF}/2$ + 0.5 LSB).

Bipolar Zero Error

This is the deviation of the midscale transition (all 0s to all 1s) from the ideal AIN(+) voltage (AIN(-) - 1/2 LSB).

Track/Hold Acquisition Time

The track/hold amplifier returns into track mode and the end of conversion. Track/Hold acquisition time is the time required for the output of the track/hold amplifier to reach its final value, within $\pm 1/2$ LSB, after the end of conversion.

Signal to (Noise + Distortion) Ratio

This is the measured ratio of signal to (noise + distortion) at the output of the A/D converter. The signal is the rms amplitude of the fundamental. Noise is the sum of all nonfundamental signals up to half the sampling frequency ($f_s/2$), excluding dc. The ratio is dependent on the number of quantization levels in the digitization process; the more levels, the smaller the quantization noise. The theoretical signal to (noise + distortion) ratio for an ideal N-bit converter with a sine wave input is given by:

$$\text{Signal to (Noise + Distortion)} = (6.02 N + 1.76) \text{ dB}$$

Thus for a 12-bit converter, this is 74 dB.

Total Harmonic Distortion

Total harmonic distortion (THD) is the ratio of the rms sum of harmonics to the fundamental. For the AD7859/AD7859L, it is defined as:

$$\text{THD (dB)} = 20 \log \frac{\sqrt{V_2^2 + V_3^2 + V_4^2 + V_5^2 + V_6^2}}{V_1}$$

where V_1 is the rms amplitude of the fundamental and V_2, V_3, V_4, V_5 and V_6 are the rms amplitudes of the second through the sixth harmonics.

Peak Harmonic or Spurious Noise

Peak harmonic or spurious noise is defined as the ratio of the rms value of the next largest component in the ADC output spectrum (up to $f_s/2$ and excluding dc) to the rms value of the fundamental. Normally, the value of this specification is determined by the largest harmonic in the spectrum, but for parts where the harmonics are buried in the noise floor, it will be a noise peak.

Intermodulation Distortion

With inputs consisting of sine waves at two frequencies, f_a and f_b , any active device with nonlinearities will create distortion products at sum and difference frequencies of $m f_a \pm n f_b$ where $m, n = 0, 1, 2, 3$, etc. Intermodulation distortion terms are those for which neither m nor n are equal to zero. For example, the second order terms include $(f_a + f_b)$ and $(f_a - f_b)$, while the third order terms include $(2f_a + f_b)$, $(2f_a - f_b)$, $(f_a + 2f_b)$ and $(f_a - 2f_b)$.

Testing is performed using the CCIF standard where two input frequencies near the top end of the input bandwidth are used. In this case, the second order terms are usually distanced in frequency from the original sine waves while the third order terms are usually at a frequency close to the input frequencies. As a result, the second and third order terms are specified separately. The calculation of the intermodulation distortion is as per the THD specification where it is the ratio of the rms sum of the individual distortion products to the rms amplitude of the sum of the fundamentals expressed in dBs.

PIN FUNCTION DESCRIPTION

Mnemonic	Description
$\overline{\text{CONVST}}$	Convert Start. Logic input. A low to high transition on this input puts the track/hold into its hold mode and starts conversion. When this input is not used, it should be tied to DV_{DD} .
$\overline{\text{RD}}$	Read Input. Active low logic input. Used in conjunction with $\overline{\text{CS}}$ to read from internal registers.
$\overline{\text{WR}}$	Write Input. Active low logic input. Used in conjunction with $\overline{\text{CS}}$ to write to internal registers.
$\overline{\text{CS}}$	Chip Select Input. Active low logic input. The device is selected when this input is active.
$\text{REF}_{\text{IN}}/\text{REF}_{\text{OUT}}$	Reference Input/Output. This pin is connected to the internal reference through a series resistor and is the reference source for the analog-to-digital converter. The nominal reference voltage is 2.5 V and this appears at the pin. This pin can be overdriven by an external reference or can be taken as high as AV_{DD} . When this pin is tied to AV_{DD} , then the C_{REF1} pin should also be tied to AV_{DD} .
AV_{DD}	Analog Supply Voltage, +3.0 V to +5.5 V.
AGND	Analog Ground. Ground reference for track/hold, reference and DAC.
DV_{DD}	Digital Supply Voltage, +3.0 V to +5.5 V.
DGND	Digital Ground. Ground reference point for digital circuitry.
C_{REF1}	Reference Capacitor (0.1 μF multilayer ceramic). This external capacitor is used as a charge source for the internal DAC. The capacitor should be tied between the pin and AGND.
C_{REF2}	Reference Capacitor (0.01 μF ceramic disc). This external capacitor is used in conjunction with the on-chip reference. The capacitor should be tied between the pin and AGND.
AIN1–AIN8	Analog Inputs. Eight analog inputs which can be used as eight single ended inputs (referenced to AGND) or four pseudo differential inputs. Channel configuration is selected by writing to the control register. None of the inputs can go below AGND or above AV_{DD} at any time. See Table III for channel selection.
$\text{W}/\overline{\text{B}}$	Word/Byte input. When this input is at a logic 1, data is transferred to and from the AD7859/AD7859L in 16-bit words on pins DB0 to DB15. When this pin is at a Logic 0, byte transfer mode is enabled. Data is transferred on pins DB0 to DB7 and pin DB8/HBEN assumes its HBEN functionality.
DB0–DB7	Data Bits 0 to 7. Three state data I/O pins that are controlled by $\overline{\text{CS}}$, $\overline{\text{RD}}$ and $\overline{\text{WR}}$. Data output is straight binary (unipolar mode) or twos complement (bipolar mode).
DB8/HBEN	Data Bit 8/High Byte Enable. When $\text{W}/\overline{\text{B}}$ is high, this pin acts as Data Bit 7, a three state data I/O pin that is controlled by $\overline{\text{CS}}$, $\overline{\text{RD}}$ and $\overline{\text{WR}}$. When $\text{W}/\overline{\text{B}}$ is low, this pin acts as the High Byte Enable pin. When HBEN is low, then the low byte of data being written to or read from the AD7859/AD7859L is on DB0 to DB7. When HBEN is high, then the high byte of data being written to or read from the AD7859/AD7859L is on DB0 to DB7.
DB9–DB15	Data Bits 9 to 15. Three state data I/O pins that are controlled by $\overline{\text{CS}}$, $\overline{\text{RD}}$ and $\overline{\text{WR}}$. Data output is straight binary (unipolar mode) or twos complement (bipolar mode).
CLKIN	Master Clock Signal for the device (4 MHz for AD7859, 1.8 MHz for AD7859L). Sets the conversion and calibration times.
$\overline{\text{CAL}}$	Calibration Input. A logic 0 in this pin resets all logic. A rising edge on this pin initiates a calibration. This input overrides all other internal operations.
BUSY	Busy Output. The busy output is triggered high when a conversion or a calibration is initiated, and remains high until the conversion or calibration is completed.
$\overline{\text{SLEEP}}$	Sleep Input. This pin is used in conjunction with the PGMT0 and PGMT1 bits in the control register to determine the power-down mode. Please see the “Power-Down Options” section for details.
NC	No connect pins. These pins should be left unconnected.

AD7859/AD7859L

AD7859/AD7859L ON-CHIP REGISTERS

The AD7859/AD7859L powers up with a set of default conditions. The only writing that is required is to select the channel configuration. Without performing any other write operations, the AD7859/AD7859L still retains the flexibility for performing a full power-down and a full self-calibration.

Extra features and flexibility such as performing different power-down options, different types of calibrations, including system calibration, and software conversion start can be selected by writing to the part.

The AD7859/AD7859L contains a **Control register**, **ADC output data register**, **Status register**, **Test register** and **10 Calibration registers**. The control register is write-only, the ADC output data register and the status register are read-only, and the test and calibration registers are both read/write registers. The test register is used for testing the part and should not be written to.

Addressing the On-Chip Registers

Writing

When writing to the AD7859/AD7859L, a 16-bit word of data must be transferred. The 16 bits of data is written as either a 16-bit word, or as two 8-bit bytes, depending on the logic level at the $\overline{W/B}$ pin. When $\overline{W/B}$ is high, the 16 bits are transferred on DB0 to DB15, where DB0 is the LSB and DB15 is the MSB of the write. When $\overline{W/B}$ is low, DB8/HBEN assumes its HBEN functionality and data is transferred in two 8-bit bytes on pins DB0 to DB7, pin DB0 being the LSB of each transfer and pin DB7 being the MSB. When writing to the AD7859/AD7859L in byte mode, the low byte must be written first followed by the high byte. The two MSBs of the complete 16-bit word, ADDR1 and ADDR0, are decoded to determine which register is addressed, and the 14 LSBs are written to the addressed register. Table I shows the decoding of the address bits, while Figure 2 shows the overall write register hierarchy.

Table I. Write Register Addressing

ADDR1	ADDR0	Comment
0	0	This combination does not address any register.
0	1	This combination addresses the TEST REGISTER . The 14 LSBs of data are written to the test register.
1	0	This combination addresses the CALIBRATION REGISTERS . The 14 LSBs of data are written to the selected calibration register.
1	1	This combination addresses the CONTROL REGISTER . The 14 LSBs of data are written to the control register.

Reading

To read from the various registers the user must first write to Bits 6 and 7 in the Control Register, RDSL0 and RDSL1. These bits are decoded to determine which register is addressed during a read operation. Table II shows the decoding of the read address bits while Figure 3 shows the overall read register hierarchy. The power-up status of these bits is 00 so that the default read will be from the ADC output data register. As with writing to the AD7859/AD7859L either word or byte mode can be used. When reading from the calibration registers in byte mode, the low byte must be read first.

Once the read selection bits are set in the control register all subsequent read operations that follow are from the selected register until the read selection bits are changed in the control register.

Table II. Read Register Addressing

RDSL1	RDSL0	Comment
0	0	All successive read operations are from the ADC OUTPUT DATA REGISTER . This is the default power-up setting. There is always four leading zeros when reading from the ADC output data register.
0	1	All successive read operations are from the TEST REGISTER .
1	0	All successive read operations are from the CALIBRATION REGISTERS .
1	1	All successive read operations are from the STATUS REGISTER .

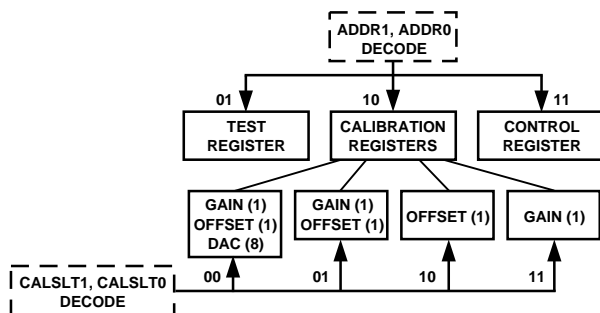

Figure 2. Write Register Hierarchy/Address Decoding

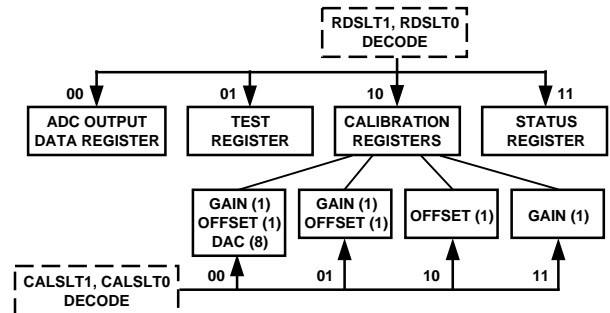

Figure 3. Read Register Hierarchy/Address Decoding

CONTROL REGISTER

The arrangement of the control register is shown below. The control register is a write only register and contains 14 bits of data. The control register is selected by putting two 1s in ADDR1 and ADDR0. The function of the bits in the control register is described below. The power-up status of all bits is 0.

MSB

SGL/DIFF	CHSLT2	CHSLT1	CHSLT0	PMGT1	PMGT0	RDSLT1
----------	--------	--------	--------	-------	-------	--------

RDSLT0	AMODE	CONVST	CALMD	CALSLT1	CALSLT0	STCAL
--------	-------	--------	-------	---------	---------	-------

LSB

CONTROL REGISTER BIT FUNCTION DESCRIPTION

Bit	Mnemonic	Comment
13	SGL/DIFF	A 0 in this bit position configures the input channels for pseudo-differential mode. A 1 in this bit position configures the input channels in single ended mode. Please see Table III for channel selection.
12	CHSLT2	These three bits are used to select the analog input on which the conversion is performed. The analog inputs can be configured as eight single-ended channels or four pseudo-differential channels. The default selection is AIN1 for the positive input and AIN2 for the negative input. Please see Table III for channel selection information.
11	CHSLT1	
10	CHSLT0	
9	PMGT1	Power Management Bits. These two bits are used with the $\overline{\text{SLEEP}}$ pin for putting the part into various Power-Down modes (See <i>Power-Down</i> section for more details).
8	PMGT0	
7	RDSLT1	These two bits determine which register is addressed for the read operations. Please see Table II.
6	RDSLT0	
5	AMODE	<p>Analog Mode Bit. This bit has two different functions, depending on the status of the SGL/DIFF bit. When SGL/DIFF is 0, AMODE selects between unipolar and bipolar analog input ranges. A logic 0 in this bit position selects the unipolar range, 0 to V_{REF} (i.e., $\text{AIN}(+) - \text{AIN}(-) = 0$ to V_{REF}). A logic 1 in this bit position selects the bipolar range $-V_{\text{REF}}/2$ to $+V_{\text{REF}}/2$ (i.e., $\text{AIN}(+) - \text{AIN}(-) = -V_{\text{REF}}/2$ to $+V_{\text{REF}}/2$). In this case AIN(-) needs to be tied to at least $+V_{\text{REF}}/2$ to allow AIN(+) to have a full input swing from 0 V to $+V_{\text{REF}}$.</p> <p>When SGL/DIFF is 1, AMODE selects the source for the AIN(-) channel of the sample and hold circuitry. If AMODE is a 0, AGND is selected. If AMODE is a 1, then AIN8 is selected. Please see Table III for more information.</p>
4	CONVST	Conversion Start Bit. A logic 1 in this bit position starts a single conversion, and this bit is automatically reset to 0 at the end of conversion. This bit may also be used in conjunction with system calibration (see calibration section on page 21).
3	CALMD	Calibration Mode Bit. A 0 here selects self-calibration and a 1 selects a system calibration (see Table IV).
2	CALSLT1	Calibration Selection Bits 1 and 0. These bits have two functions, depending on the STCAL bit. With the STCAL bit set to 1, the CALSLT1 and CALSLT0 bits, along with the CALMD bit, determine the type of calibration performed by the part (see Table IV). With the STCAL bit set to 0, the CALSLT1 and CALSLT0 bits are decoded to address the calibration register for read/write of calibration coefficients (see Table V for more details).
1	CALSLT0	
0	STCAL	Start Calibration Bit. When STCAL is set to a 1, a calibration is performed, as determined by the CALMD, CALSLT1 and CALSLT0 bits. Please see Table IV. When STCAL is set to a zero, no calibration is performed.

AD7859/AD7859L

**Table IIIa. Channel Selection for AD7859/AD7859L
Differential Sampling (SGL/DIFF = 0)**

AMODE	CHSLT			AIN(+)*AIN(-)*		Bipolar or Unipolar
	2	1	0			
0	0	0	0	AIN1	AIN2	Unipolar
0	0	0	1	AIN3	AIN4	Unipolar
0	0	1	0	AIN5	AIN6	Unipolar
0	0	1	1	AIN7	AIN8	Unipolar
0	1	x	x	x	x	Not Used
1	0	0	0	AIN1	AIN2	Bipolar
1	0	0	1	AIN3	AIN4	Bipolar
1	0	1	0	AIN5	AIN6	Bipolar
1	0	1	1	AIN7	AIN8	Bipolar
1	1	x	x	x	x	Not Used

*AIN(+) refers to the positive input seen by the AD7859/AD7859L sample-and-hold circuitry.

AIN(-) refers to the negative input seen by the AD7859/AD7859L sample-and-hold circuitry.

**Table IIIb. Channel Selection for AD7859/AD7859L
Single-Ended Sampling (SGL/DIFF = 1)**

AMODE	CHSLT			AIN(+)*AIN(-)*		Bipolar or Unipolar
	2	1	0			
0	0	0	0	AIN1	AGND	Unipolar
0	0	0	1	AIN3	AGND	Unipolar
0	0	1	0	AIN5	AGND	Unipolar
0	0	1	1	AIN7	AGND	Unipolar
0	1	0	0	AIN2	AGND	Unipolar
0	1	0	1	AIN4	AGND	Unipolar
0	1	1	0	AIN6	AGND	Unipolar
0	1	1	1	AIN8	AGND	Unipolar
1	0	0	0	AIN1	AIN8	Unipolar
1	0	0	1	AIN3	AIN8	Unipolar
1	0	1	0	AIN5	AIN8	Unipolar
1	0	1	1	AIN7	AIN8	Unipolar
1	1	0	0	AIN2	AIN8	Unipolar
1	1	0	1	AIN4	AIN8	Unipolar
1	1	1	0	AIN6	AIN8	Unipolar
1	1	1	1	AIN8	AIN8	Unipolar

Table IV. Calibration Selection

CALMD	CALSLT1	CALSLT0	Calibration Type
0	0	0	A full internal calibration is initiated. First the internal DAC is calibrated, then the internal gain error and finally the internal offset error are removed. This is the default setting.
0	0	1	First the internal gain error is removed, then the internal offset error is removed.
0	1	0	The internal offset error only is calibrated out.
0	1	1	The internal gain error only is calibrated out.
1	0	0	A full system calibration is initiated. First the internal DAC is calibrated, followed by the system gain error calibration, and finally the system offset error calibration.
1	0	1	First the system gain error is calibrated out, followed by the system offset error .
1	1	0	The system offset error only is removed.
1	1	1	The system gain error only is removed.

STATUS REGISTER

The arrangement of the status register is shown below. The status register is a read-only register and contains 16 bits of data. The status register is selected by first writing to the control register and putting two 1s in RDSL1 and RDSL0. The function of the bits in the status register are described below. The power-up status of all bits is 0.

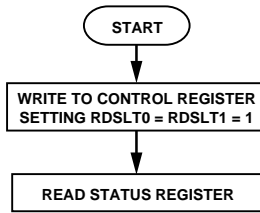

Figure 4. Flowchart for Reading the Status Register

MSB							
ZERO	ZERO	SGL/DIFF	CHSLT2	CHSLT1	CHSLT0	PMGT1	PMGT0
ONE	ONE	AMODE	BUSY	CALMD	CALSLT1	CALSLT0	STCAL
LSB							

STATUS REGISTER BIT FUNCTION DESCRIPTION

Bit	Mnemonic	Comment
15	ZERO	These two bits are always 0.
14	ZERO	
13	SGL/DIFF	Single/Differential Bit.
12	CHSLT2	Channel Selection Bits. These bits, in conjunction with the SGL/DIFF bit, determine which channel has been selected for conversion. Please refer to Table IIIa and Table IIIb.
11	CHSLT1	
10	CHSLT0	
9	PMGT1	Power Management Bits. These bits along with the SLEEP pin indicate if the part is in a power-down mode or not. See Table VI in Power-Down Section for description.
8	PMGT0	
7	ONE	Both these bits are always 1.
6	ONE	
5	AMODE	Analog Mode Bit. This bit is used along with SGL/DIFF and CHSLT2 – CHSLT0 to determine the AIN(+) and AIN(-) inputs to the track and hold circuitry and the analog conversion mode (unipolar or bipolar). Please see Table III for details.
4	BUSY	Conversion/Calibration BUSY Bit. When this bit is a 1, there is a conversion or a calibration in progress. When this bit is a zero, there is no conversion or calibration in progress.
3	CALMD	Calibration Mode Bit. A 0 in this bit indicates a self-calibration is selected, and a 1 in this bit indicates a system calibration is selected (see Table IV).
2	CALSLT1	Calibration Selection Bits. The CALSLT1 and CALSLT0 bits indicate which of the calibration registers are addressed for reading and writing (see section on the Calibration Registers for more details).
1	CALSLT0	
0	STCAL	Start Calibration Bit. The STCAL bit is a 1 if a calibration is in progress and a 0 if there is no calibration in progress.

AD7859/AD7859L

CALIBRATION REGISTERS

The AD7859/AD7859L has 10 calibration registers in all, 8 for the DAC, 1 for offset and 1 for gain. Data can be written to or read from all 10 calibration registers. In self and system calibration, the part automatically modifies the calibration registers; only if the user needs to modify the calibration registers should an attempt be made to read from and write to the calibration registers.

Addressing the Calibration Registers

The calibration selection bits in the control register CALSLT1 and CALSLT0 determine which of the calibration registers are addressed (See Table V). The addressing applies to both the read and write operations for the calibration registers. The user should not attempt to read from and write to the calibration registers at the same time.

Table V. Calibration Register Addressing

CALSLT1	CALSLT0	Comment
0	0	This combination addresses the Gain (1), Offset (1) and DAC Registers (8) . Ten registers in total.
0	1	This combination addresses the Gain (1) and Offset (1) Registers . Two registers in total.
1	0	This combination addresses the Offset Register . One register in total.
1	1	This combination addresses the Gain Register . One register in total.

Writing to/Reading from the Calibration Registers

When writing to the calibration registers a write to the control register is required to set the CALSLT0 and CALSLT1 bits. When reading from the calibration registers a write to the control register is required to set the CALSLT0 and CALSLT1 bits and also to set the RDSLT1 and RDSLT0 bits to 10 (this addresses the calibration registers for reading). The calibration register pointer is reset on writing to the control register setting the CALSLT1 and CALSLT0 bits, or upon completion of all the calibration register write/read operations. When reset it points to the first calibration register in the selected write/read sequence. The calibration register pointer points to the gain calibration register upon reset in all but one case, this case being where the offset calibration register is selected on its own (CALSLT1 = 1, CALSLT0 = 0). Where more than one calibration register is being accessed, the calibration register pointer is automatically incremented after each full calibration register write/read operation. The calibration register address pointer is incremented after the high byte read or write operation in byte mode. Therefore when reading (in byte mode) from the calibration registers, the low byte must always be read first, i.e., HBEN = logic zero. The order in which the 10 calibration registers are arranged is shown in Figure 5. Read/Write operations may be aborted at any time before all the calibration registers have been accessed, and the next control register write operation resets the calibration register pointer. The flowchart in Figure 6 shows the sequence for writing to the calibration registers. Figure 7 shows the sequence for reading from the calibration registers.

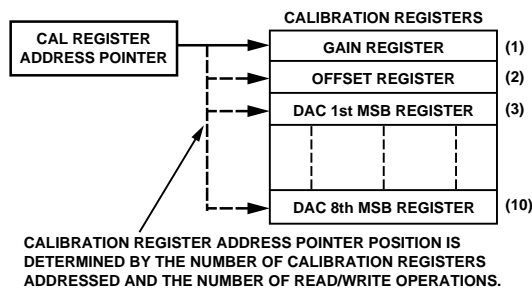

Figure 5. Calibration Register Arrangement

When reading from the calibration registers there is always two leading zeros for each of the registers.

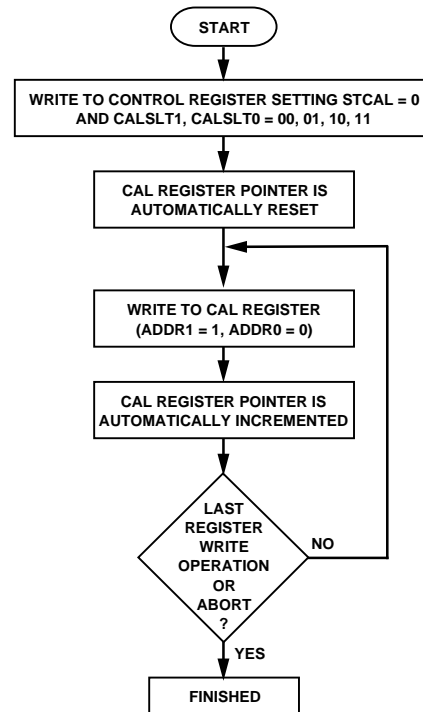

Figure 6. Flowchart for Writing to the Calibration Registers

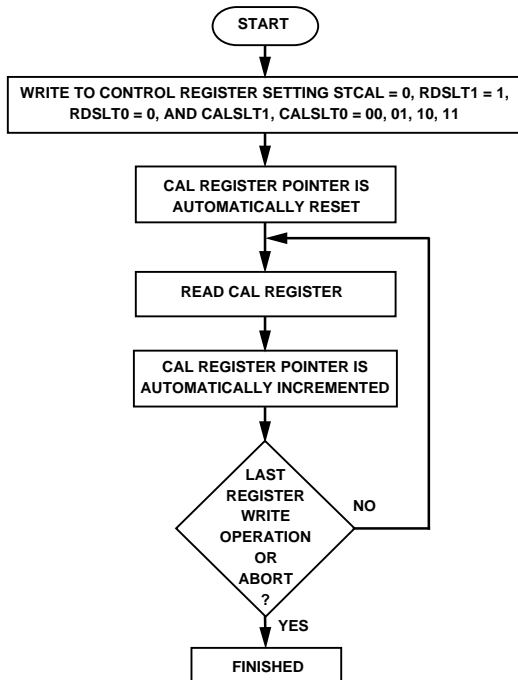

Figure 7. Flowchart for Reading from the Calibration Registers

Adjusting the Offset Calibration Register

The offset calibration register contains 16 bits. The two MSBs are zero and the 14 LSBs contain offset data. By changing the contents of the offset register, different amounts of offset on the analog input signal can be compensated for. Decreasing the number in the offset calibration register compensates for negative offset on the analog input signal, and increasing the number in the offset calibration register compensates for positive offset on the analog input signal. The default value of the offset calibration register is 0010 0000 0000 0000 approximately. This is not the exact value, but the value in the offset register should be close to this value. Each of the 14 data bits in the offset register is binary weighted; the MSB has a weighting of 5% of the refer-

ence voltage, the MSB-1 has a weighting of 2.5%, the MSB-2 has a weighting of 1.25%, and so on down to the LSB which has a weighting of 0.0006%. This gives a resolution of $\pm 0.0006\%$ of V_{REF} approximately. The resolution can also be expressed as $\pm (0.05 \times V_{REF})/2^{13}$ volts. This equals ± 0.015 mV, with a 2.5 V reference. The maximum offset that can be compensated for is $\pm 5\%$ of the reference voltage, which equates to ± 125 mV with a 2.5 V reference and ± 250 mV with a 5 V reference.

- Q. If a +20 mV offset is present in the analog input signal and the reference voltage is 2.5 V, what code needs to be written to the offset register to compensate for the offset ?
- A. 2.5 V reference implies that the resolution in the offset register is $5\% \times 2.5 \text{ V}/2^{13} = 0.015$ mV. $+20 \text{ mV}/0.015 \text{ mV} = 1310.72$; rounding to the nearest number gives 1311. In binary terms this is 00 0101 0001 1111, therefore increase the offset register by 00 0101 0001 1111.

This method of compensating for offset in the analog input signal allows for fine tuning the offset compensation. If the offset on the analog input signal is known, there is no need to apply the offset voltage to the analog input pins and do a system calibration. The offset compensation can take place in software.

Adjusting the Gain Calibration Register

The gain calibration register contains 16 bits. The two MSBs are zero and the 14 LSBs contain gain data. As in the offset calibrating register the data bits in the gain calibration register are binary weighted, with the MSB having a weighting of 2.5% of the reference voltage. The gain register value is effectively multiplied by the analog input to scale the conversion result over the full range. Increasing the gain register compensates for a smaller analog input range and decreasing the gain register compensates for a larger input range. The maximum analog input range that the gain register can compensate for is 1.025 times the reference voltage, and the minimum input range is 0.975 times the reference voltage.

AD7859/AD7859L

CIRCUIT INFORMATION

The AD7859/AD7859L is a fast, 8-channel, 12-bit, single supply A/D converter. The part requires an external 4 MHz/1.8 MHz master clock (CLKIN), two C_{REF} capacitors, a \overline{CONVST} signal to start conversion and power supply decoupling capacitors. The part provides the user with track/hold, on-chip reference, calibration features, A/D converter and parallel interface logic functions on a single chip. The A/D converter section of the AD7859/AD7859L consists of a conventional successive-approximation converter based around a capacitor DAC. The AD7859/AD7859L accepts an analog input range of 0 to $+V_{REF}$. V_{REF} can be tied to V_{DD} . The reference input to the part connected via a 150 k Ω resistor to the internal 2.5 V reference and to the on-chip buffer.

A major advantage of the AD7859/AD7859L is that a conversion can be initiated in software, as well as by applying a signal to the \overline{CONVST} pin. The part is available in a 44-pin PLCC or a 44-pin PQFP package, and this offers the user considerable spacing saving advantages over alternative solutions. The AD7859L version typically consumes only 5.5 mW making it ideal for battery-powered applications.

CONVERTER DETAILS

The master clock for the part is applied to the CLKIN pin. Conversion is initiated on the AD7859/AD7859L by pulsing the \overline{CONVST} input or by writing to the control register and setting the \overline{CONVST} bit to 1. On the rising edge of \overline{CONVST} (or at the end of the control register write operation), the on-chip track/hold goes from track to hold mode. The falling edge of the CLKIN signal which follows the rising edge of \overline{CONVST} initiates the conversion, provided the rising edge of \overline{CONVST} (or \overline{WR} when converting via the control register) occurs typically at least 10 ns before this CLKIN edge. The conversion takes 16.5 CLKIN periods from this CLKIN falling edge. If the 10 ns setup time is not met, the conversion takes 17.5 CLKIN periods.

The time required by the AD7859/AD7859L to acquire a signal depends upon the source resistance connected to the AIN(+) input. Please refer to the *acquisition time* section for more details.

When a conversion is completed, the BUSY output goes low, and the result of the conversion can be read by accessing the data through the data bus. To obtain optimum performance from the part, read or write operations should not occur during the conversion or less than 200 ns prior to the next \overline{CONVST} rising edge. Reading/writing during conversion typically degrades the Signal-to-(Noise + Distortion) by less than 0.5 dBs. The AD7859 can operate at throughput rates of over 200 kSPS (up to 100 kSPS for the AD7859L).

With the AD7859L, 100 kSPS throughput can be obtained as follows: the CLKIN and \overline{CONVST} signals are arranged to give a conversion time of 16.5 CLKIN periods as described above

and 1.5 CLKIN periods are allowed for the acquisition time. With a 1.8 MHz clock, this gives a full cycle time of 10 μ s, which equates to a throughput rate of 100 kSPS.

When using the software conversion start for maximum throughput, the user must ensure the control register write operation extends beyond the falling edge of BUSY. The falling edge of BUSY resets the \overline{CONVST} bit to 0 and allows it to be reprogrammed to 1 to start the next conversion.

TYPICAL CONNECTION DIAGRAM

Figure 8 shows a typical connection diagram for the AD7859/AD7859L. The AGND and the DGND pins are connected together at the device for good noise suppression. The first \overline{CONVST} applied after power-up starts a self-calibration sequence. This is explained in the calibration section of this data sheet. Note that after power is applied to AV_{DD} and DV_{DD} and the \overline{CONVST} signal is applied, the part requires (70 ms + 1/sample rate) for the internal reference to settle and for the self-calibration on power-up to be completed.

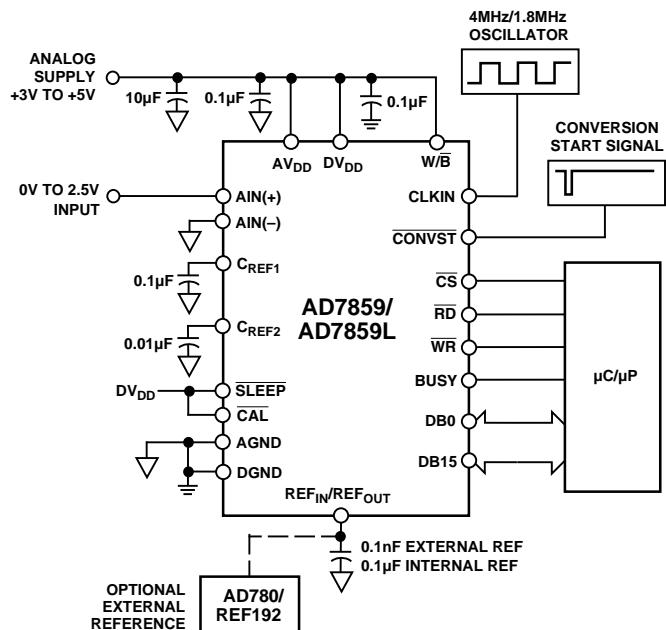

Figure 8. Typical Circuit

For applications where power consumption is a major concern, the power-down options can be exercised by writing to the part and using the SLEEP pin. See the *Power-Down* section for more details on low power applications.

ANALOG INPUT

The equivalent analog input circuit is shown in Figure 9. AIN(+) is the channel connected to the positive input of the track/hold circuitry and AIN(-) is the channel connected to the negative input. Please refer to Table IIIa and Table IIIb for channel configuration.

During the acquisition interval the switches are both in the track position and the AIN(+) charges the 20 pF capacitor through the 125 Ω resistance. The rising edge of $\overline{\text{CONVST}}$ switches SW1 and SW2 go into the hold position retaining charge on the 20 pF capacitor as a sample of the signal on AIN(+). The AIN(-) is connected to the 20 pF capacitor, and this unbalances the voltage at node A at the input of the comparator. The capacitor DAC adjusts during the remainder of the conversion cycle to restore the voltage at node A to the correct value. This action transfers a charge, representing the analog input signal, to the capacitor DAC which in turn forms a digital representation of the analog input signal. The voltage on the AIN(-) pin directly influences the charge transferred to the capacitor DAC at the hold instant. If this voltage changes during the conversion period, the DAC representation of the analog input voltage is altered. Therefore it is most important that the voltage on the AIN(-) pin remains constant during the conversion period. Furthermore, it is recommended that the AIN(-) pin is always connected to AGND or to a fixed dc voltage.

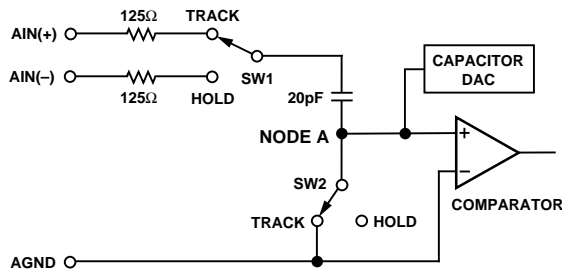

Figure 9. Analog Input Equivalent Circuit

Acquisition Time

The track-and-hold amplifier enters its tracking mode on the falling edge of the BUSY signal. The time required for the track-and-hold amplifier to acquire an input signal will depend on how quickly the 20 pF input capacitance is charged. There is a minimum acquisition time of 400 ns. This includes the time required to change channels. For large source impedances, >2 k Ω , the acquisition time is calculated using the formula:

$$t_{ACQ} = 9 \times (R_{IN} + 125 \Omega) \times 20 \text{ pF}$$

where R_{IN} is the source impedance of the input signal, and 125 Ω , 20 pF is the input R, C.

DC/AC Applications

For dc applications, high source impedances are acceptable, provided there is enough acquisition time between conversions to charge the 20 pF capacitor. For example with $R_{IN} = 5 \text{ k}\Omega$, the required acquisition time is 922 ns.

For ac applications, removing high frequency components greater than the Nyquist frequency from the analog input signal is recommended by use of a low-pass filter on the AIN(+) pin, as shown in Figure 11. In applications where harmonic distortion and signal to noise ratio are critical, the analog input should be driven from a low impedance source. Large source impedances significantly affect the ac performance of the ADC. They may require the use of an input buffer amplifier. The choice of the amplifier is a function of the particular application.

The maximum source impedance depends on the amount of total harmonic distortion (THD) that can be tolerated. The THD increases as the source impedance increases. Figure 10 shows a graph of the Total Harmonic Distortion vs. analog input signal frequency for different source impedances. With the setup as in Figure 11, the THD is at the -90 dB level. With a source impedance of 1 k Ω and no capacitor on the AIN(+) pin, the THD increases with frequency.

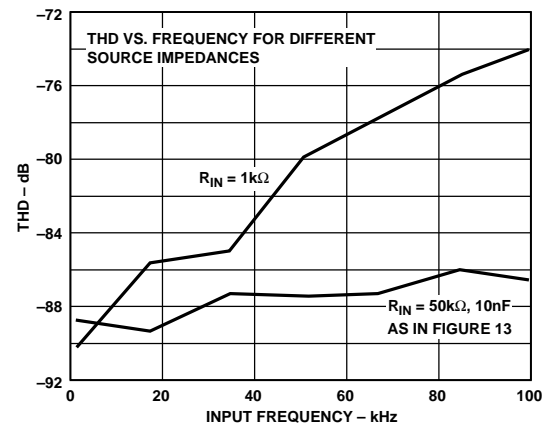

Figure 10. THD vs. Analog Input Frequency

In a single supply application (both 3 V and 5 V), the V+ and V- of the op amp can be taken directly from the supplies to the AD7859/AD7859L which eliminates the need for extra external power supplies. When operating with rail-to-rail inputs and outputs at frequencies greater than 10 kHz, care must be taken in selecting the particular op amp for the application. In particular, for single supply applications the input amplifiers should be connected in a gain of -1 arrangement to get the optimum performance. Figure 11 shows the arrangement for a single supply application with a 50 Ω and 10 nF low-pass filter (cutoff frequency 320 kHz) on the AIN(+) pin. Note that the 10 nF is a capacitor with good linearity to ensure good ac performance. Recommended single supply op amps are the AD820 and the AD820-3V.

AD7859/AD7859L

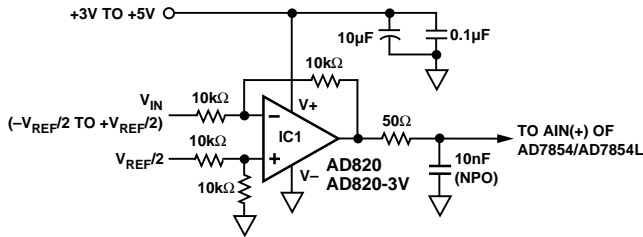

Figure 11. Analog Input Buffering

Input Ranges

The analog input range for the AD7859/AD7859L is 0 V to V_{REF} in both the unipolar and bipolar ranges.

The difference between the unipolar range and the bipolar range is that in the bipolar range the $AIN(-)$ should be biased up to at least $+V_{REF}/2$ and the output coding is 2s complement (See Table VI and Figures 14 and 15).

Table VI. Analog Input Connections

Analog Input Range	Input Connections	Connection Diagram
	$AIN(+)$ $AIN(-)$	
0 V to V_{REF} ¹	V_{IN} AGND	Figure 12
$\pm V_{REF}/2$ ²	V_{IN} $V_{REF}/2$	Figure 13

NOTES

¹Output code format is straight binary.

²Range is $\pm V_{REF}/2$ biased about $V_{REF}/2$. Output code format is 2s complement.

Note that the $AIN(-)$ channel on the AD7859/AD7859L can be biased up above AGND in the unipolar mode, or above $V_{REF}/2$ in bipolar mode if required. The advantage of biasing the lower end of the analog input range away from AGND is that the analog input does not have to swing all the way down to AGND. Thus, in single supply applications the input amplifier does not have to swing all the way down to AGND. The upper end of the analog input range is shifted up by the same amount. Care must be taken so that the bias applied does not shift the upper end of the analog input above the AV_{DD} supply. In the case where the reference is the supply, AV_{DD} , the $AIN(-)$ should be tied to AGND in unipolar mode or to $AV_{DD}/2$ in bipolar mode.

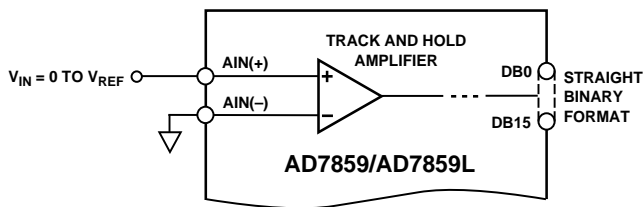

Figure 12. 0 to V_{REF} Unipolar Input Configuration

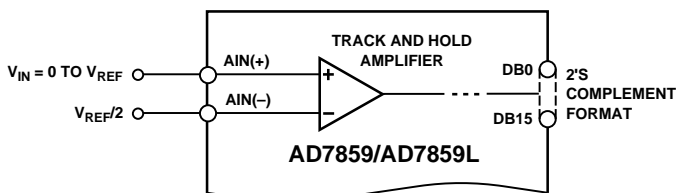

Figure 13. $\pm V_{REF}/2$ about $V_{REF}/2$ Bipolar Input Configuration

Transfer Functions

For the unipolar range the designed code transitions occur midway between successive integer LSB values (i.e., $1/2$ LSB, $3/2$ LSBs, $5/2$ LSBs . . . $FS - 3/2$ LSBs). The output coding is straight binary for the unipolar range with $1 \text{ LSB} = FS/4096 = 3.3 \text{ V}/4096 = 0.8 \text{ mV}$ when $V_{REF} = 3.3 \text{ V}$. Figure 12 shows the unipolar analog input configuration. The ideal input/output transfer characteristic for the unipolar range is shown in Figure 14.

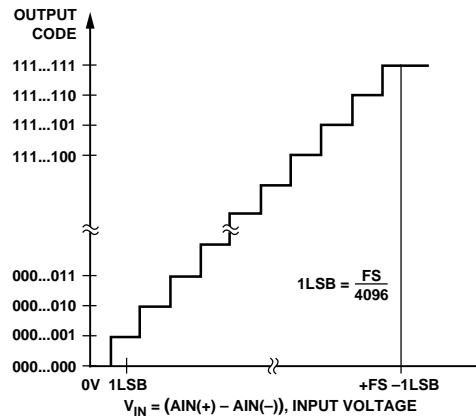

Figure 14. AD7859/AD7859L Unipolar Transfer Characteristic

Figure 13 shows the AD7859/AD7859L's $\pm V_{REF}/2$ bipolar analog input configuration. $AIN(+)$ cannot go below 0 V so for the full bipolar range, $AIN(-)$ should be biased to at least $+V_{REF}/2$. Once again the designed code transitions occur midway between successive integer LSB values. The output coding is 2s complement with $1 \text{ LSB} = 4096 = 3.3 \text{ V}/4096 = 0.8 \text{ mV}$. The ideal input/output transfer characteristic is shown in Figure 15.

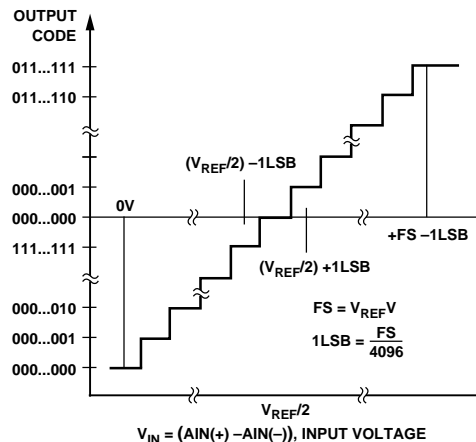

Figure 15. AD7859/AD7859L Bipolar Transfer Characteristic

REFERENCE SECTION

For specified performance, it is recommended that when using an external reference, this reference should be between 2.3 V and the analog supply AV_{DD} . The connections for the reference pins are shown below. If the internal reference is being used, the REF_{IN}/REF_{OUT} pin should be decoupled with a 100 nF capacitor to AGND very close to the REF_{IN}/REF_{OUT} pin. These connections are shown in Figure 16.

If the internal reference is required for use external to the ADC, it should be buffered at the REF_{IN}/REF_{OUT} pin and a 100 nF capacitor should be connected from this pin to AGND. The typical noise performance for the internal reference, with 5 V supplies is 150 nV/ $\sqrt{\text{Hz}}$ @ 1 kHz and dc noise is 100 μV p-p.

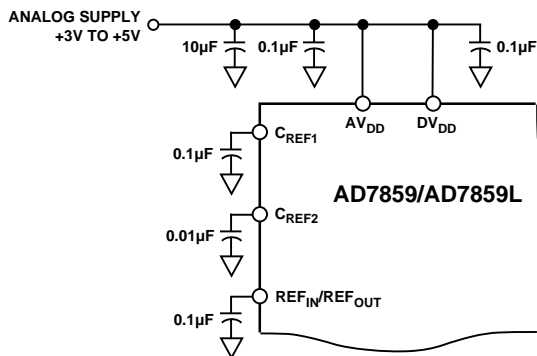

Figure 16. Relevant Connections Using Internal Reference

The REF_{IN}/REF_{OUT} pin may be overdriven by connecting it to an external reference. This is possible due to the series resistance from the REF_{IN}/REF_{OUT} pin to the internal reference. This external reference can be in the range 2.3 V to AV_{DD} . When using AV_{DD} as the reference source, the 10 nF capacitor from the REF_{IN}/REF_{OUT} pin to AGND should be as close as possible to the REF_{IN}/REF_{OUT} pin, and also the C_{REF1} pin should be connected to AV_{DD} to keep this pin at the same voltage as the reference. The connections for this arrangement are shown in Figure 17. When using AV_{DD} it may be necessary to add a resistor in series with the AV_{DD} supply. This has the effect of filtering the noise associated with the AV_{DD} supply.

Note that when using an external reference, the voltage present at the REF_{IN}/REF_{OUT} pin is determined by the external reference source resistance and the series resistance of 150 k Ω from the REF_{IN}/REF_{OUT} pin to the internal 2.5 V reference. Thus, a low source impedance external reference is recommended.

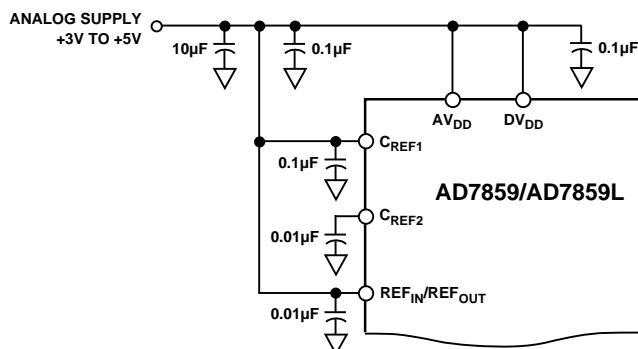

Figure 17. Relevant Connections, AV_{DD} as the Reference

AD7859/AD7859L PERFORMANCE CURVES

Figure 18 shows a typical FFT plot for the AD7859 at 200 kHz sample rate and 10 kHz input frequency.

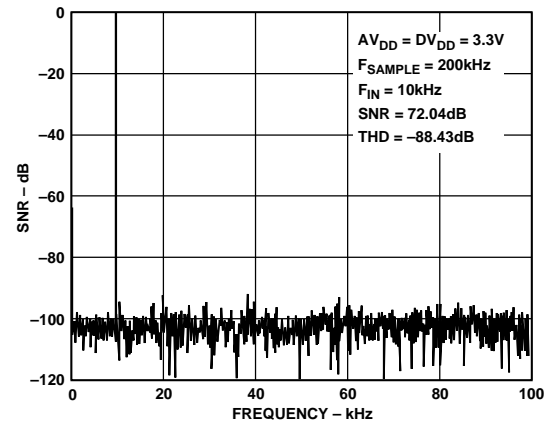

Figure 18. FFT Plot

Figure 19 shows the SNR versus Frequency for different supplies and different external references.

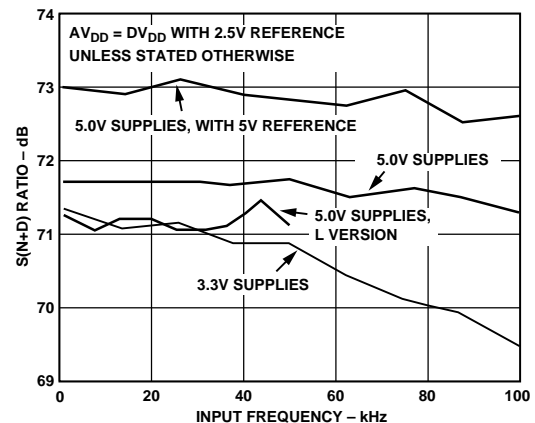

Figure 19. SNR vs. Frequency

Figure 20 shows the Power Supply Rejection Ratio versus Frequency for the part. The Power Supply Rejection Ratio is defined as the ratio of the power in ADC output at frequency f to the power of a full-scale sine wave.

$$PSRR \text{ (dB)} = 10 \log (P_f/P_{fs})$$

P_f = Power at frequency f in ADC output, P_{fs} = power of a full-scale sine wave. Here a 100 mV peak-to-peak sine wave is coupled onto the AV_{DD} supply while the digital supply is left unaltered. Both the 3.3 V and 5.0 V supply performances are shown.

AD7859/AD7859L

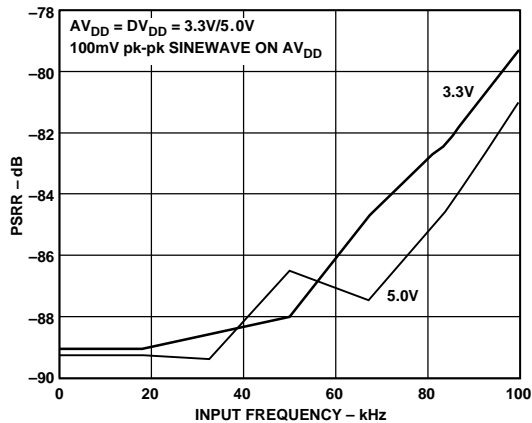

Figure 20. PSRR vs. Frequency

POWER-DOWN OPTIONS

The AD7859/AD7859L provides flexible power management to allow the user to achieve the best power performance for a given throughput rate. The power management options are selected by programming the power management bits, PMGT1 and PMGT0, in the control register and by use of the $\overline{\text{SLEEP}}$ pin. Table VII summarizes the power-down options that are available and how they can be selected by using either software, hardware or a combination of both. The AD7859/AD7859L can be fully or partially powered down. When fully powered down, all the on-chip circuitry is powered down and I_{DD} is 10 μA typ. If a partial power-down is selected, then all the on-chip circuitry except the reference is powered down and I_{DD} is 400 μA typ. The choice of full or partial power-down does not give any significant improvement in throughput with a power-down between conversions. This is discussed in the next section—*Power-Up Times*. But a partial power-down does allow the on-chip reference to be used externally even though the rest of the AD7859/AD7859L circuitry is powered down. It also allows the AD7859/AD7859L to be powered up faster after a long power-down period when using the on-chip reference (See *Power-Up Times—Using On-Chip Reference*).

When using the $\overline{\text{SLEEP}}$ pin, the power management bits PMGT1 and PMGT0 should be set to zero. Bringing the $\overline{\text{SLEEP}}$ pin logic high ensures normal operation, and the part does not power down at any stage. This may be necessary if the part is being used at high throughput rates when it is not possible to power down between conversions. If the user wishes to power down between conversions at lower throughput rates (i.e., <100 kSPS for the AD7859 and <60 kSPS for the AD7859L) to achieve better power performances, then the $\overline{\text{SLEEP}}$ pin should be tied logic low.

If the power-down options are to be selected in software only, then the $\overline{\text{SLEEP}}$ pin should be tied logic high. By setting the power management bits PMGT1 and PMGT0 as shown in Table VII, a Full Power-Down, Full Power-Up, Full Power-Down Between Conversions, and a Partial Power-Down Between Conversions can be selected.

A combination of hardware and software selection can also be used to achieve the desired effect.

Table VII. Power Management Options

PMGT1 Bit	PMGT0 Bit	$\overline{\text{SLEEP}}$ Pin	Comment
0	0	0	Full Power-Down Between Conversions (HW / SW)
0	0	1	Full Power-Up (HW / SW)
0	1	X	Full Power-Down Between Conversions (SW)
1	0	X	Full Power-Down (SW)
1	1	X	Partial Power-Down Between Conversions (SW)

NOTE

SW = Software selection, HW = Hardware selection.

POWER-UP TIMES

Using An External Reference

When the AD7859/AD7859L are powered up, the parts are powered up from one of two conditions. First, when the power supplies are initially powered up and, secondly, when the parts are powered up from either a hardware or software power-down (see last section).

When AV_{DD} and DV_{DD} are powered up, the AD7859/AD7859L enters a mode whereby the $\overline{\text{CONVST}}$ signal initiates a timeout followed by a self-calibration. The total time taken for this timeout and calibration is approximately 70 ms—see *Calibration on Power-Up* in the *calibration* section of this data sheet. During power-up the functionality of the $\overline{\text{SLEEP}}$ pin is disabled, i.e., the part will not power down until the end of the calibration if $\overline{\text{SLEEP}}$ is tied logic low. The power-up calibration mode can be disabled if the user writes to the control register before a $\overline{\text{CONVST}}$ signal is applied. If the time out and self-calibration are disabled, then the user must take into account the time required by the AD7859/AD7859L to power up before a self-calibration is carried out. This power-up time is the time taken for the AD7859/AD7859L to power up when power is first applied (300 μs typ) or the time it takes the external reference to settle to the 12-bit level—whichever is the longer.

The AD7859/AD7859L powers up from a full hardware or software power-down in 5 μs typ. This limits the throughput which the part is capable of to 100 kSPS for the AD7859 and 60 kSPS for the AD7859L when powering down between conversions. Figure 21 shows how power-down between conversions is implemented using the $\overline{\text{CONVST}}$ pin. The user first selects the power-down between conversions option by using the $\overline{\text{SLEEP}}$ pin and the power management bits, PMGT1 and PMGT0, in the control register. See last section. In this mode the AD7859/AD7859L automatically enters a full power-down at the end of a conversion, i.e., when $\overline{\text{BUSY}}$ goes low. The falling edge of the next $\overline{\text{CONVST}}$ pulse causes the part to power up. Assuming the external reference is left powered up, the AD7859/AD7859L should be ready for normal operation 5 μs after this falling edge. The rising edge of $\overline{\text{CONVST}}$ initiates a conversion so the $\overline{\text{CONVST}}$ pulse should be at least 5 μs wide. The part automatically powers down on completion of the conversion. Where the software convert start is used, the part may be powered up in software before a conversion is initiated.

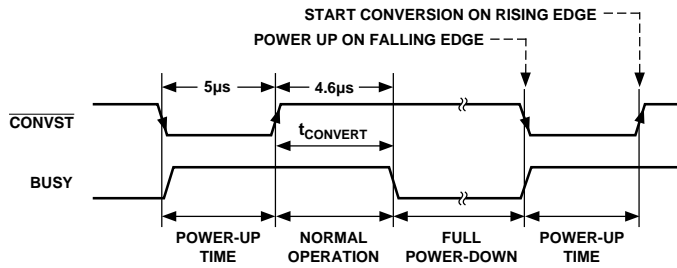

Figure 21. Using the CONVST Pin to Power Up the AD7859 for a Conversion

Using The Internal (On-Chip) Reference

As in the case of an external reference, the AD7859/AD7859L can power up from one of two conditions, power-up after the supplies are connected or power-up from hardware/software power-down.

When using the on-chip reference and powering up when AV_{DD} and DV_{DD} are first connected, it is recommended that the power-up calibration mode be disabled as explained above. When using the on-chip reference, the power-up time is effectively the time it takes to charge up the external capacitor on the REF_{IN}/REF_{OUT} pin. This time is given by the equation:

$$t_{UP} = 9 \times R \times C$$

where $R \approx 150K$ and C = external capacitor.

The recommended value of the external capacitor is 100 nF; this gives a power-up time of approximately 135 ms before a calibration is initiated and normal operation should commence.

When C_{REF} is fully charged, the power-up time from a hardware or software power-down reduces to 5 µs. This is because an internal switch opens to provide a high impedance discharge path for the reference capacitor during power-down—see Figure 22. An added advantage of the low charge leakage from the reference capacitor during power-down is that even though the reference is being powered down between conversions, the reference capacitor holds the reference voltage to within 0.5 LSBs with throughput rates of 100 samples/second and over with a full power-down between conversions. A high input impedance op amp like the AD707 should be used to buffer this reference capacitor if it is being used externally. Note, if the AD7859/AD7859L is left in its powered-down state for more than 100 ms, the charge on C_{REF} will start to leak away and the power-up time will increase. If this long power-up time is a problem, the user can use a partial power-down for the last conversion so the reference remains powered up.

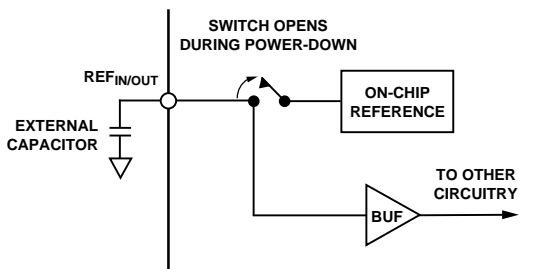

Figure 22. On-Chip Reference During Power-Down

POWER VS. THROUGHPUT RATE

The main advantage of a full power-down after a conversion is that it significantly reduces the power consumption of the part at lower throughput rates. When using this mode of operation, the AD7859/AD7859L is only powered up for the duration of the conversion. If the power-up time of the AD7859/AD7859L is taken to be 5 µs and it is assumed that the current during power up is 4.5 mA/1.5 mA typ, then power consumption as a function of throughput can easily be calculated. The AD7859 has a conversion time of 4.6 µs with a 4 MHz external clock and the AD7859L has a conversion time of 9 µs with a 1.8 MHz clock. This means the AD7859/AD7859L consumes 4.5 mA/1.5 mA typ for 9.6 µs/14 µs in every conversion cycle if the parts are powered down at the end of a conversion. The two graphs, Figure 24 and Figure 25, show the power consumption of the AD7859 and AD7859L for V_{DD} = 3 V as a function of throughput. Table VIII lists the power consumption for various throughput rates.

Table VIII. Power Consumption vs. Throughput

Throughput Rate	Power AD7859	Power AD7859L
1 kSPS	130 µW	65 µW
10 kSPS	1.3 mW	650 µW
20 kSPS	2.6 mW	1.25 mW
50 kSPS	6.48 mW	3.2 mW

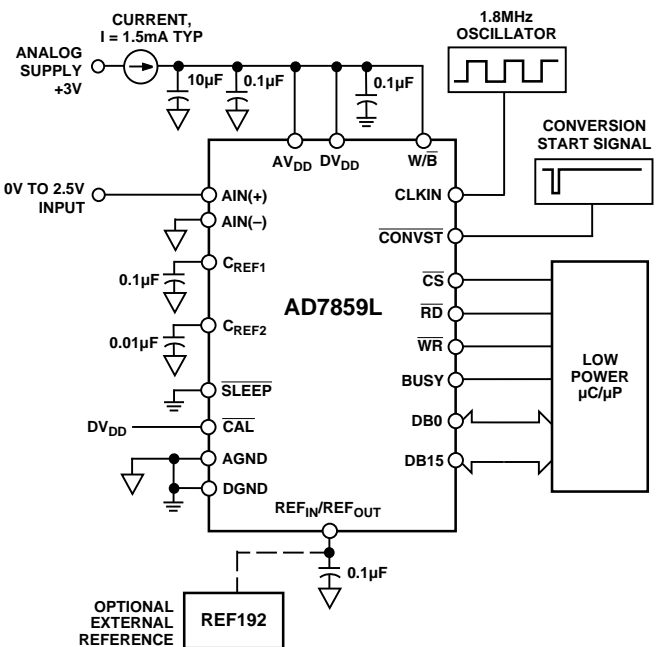

Figure 23. Typical Low Power Circuit

AD7859/AD7859L

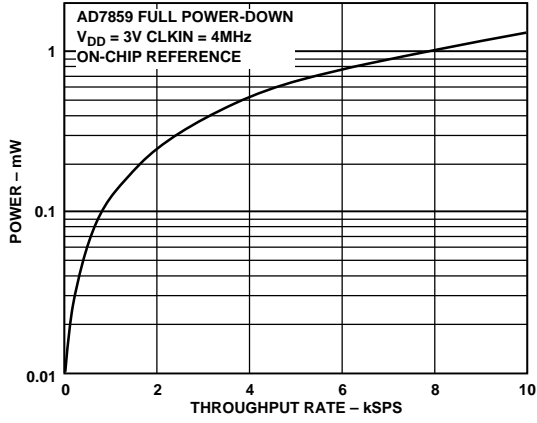

Figure 24. Power vs. Throughput AD7859

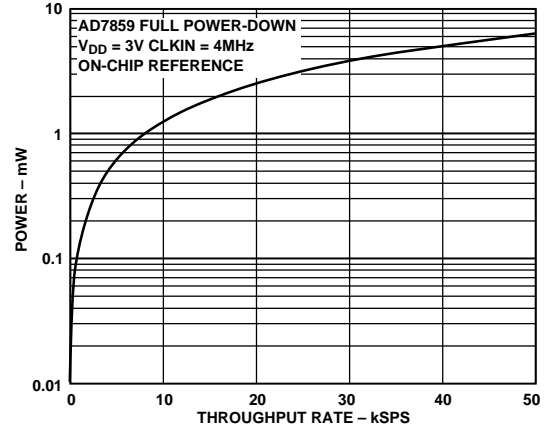

Figure 26. Power vs. Throughput AD7859

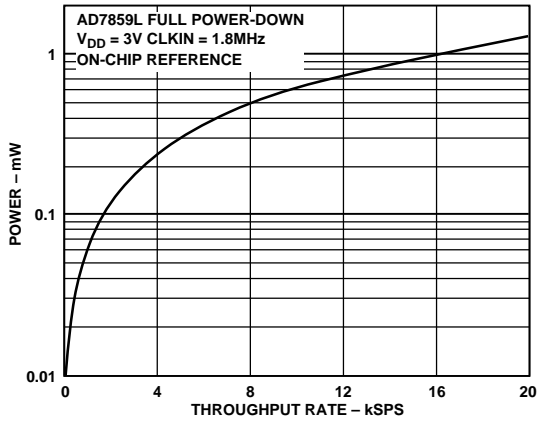

Figure 25. Power vs. Throughput AD7859L

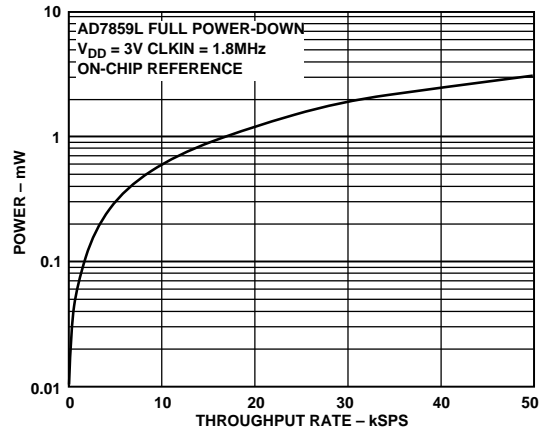

Figure 27. Power vs. Throughput AD7859L

CALIBRATION SECTION

Calibration Overview

The automatic calibration that is performed on power-up ensures that the calibration options covered in this section are not required in a significant number of applications. A calibration does not have to be initiated unless the operating conditions change (CLKIN frequency, analog input mode, reference voltage, temperature, and supply voltages). The AD7859/AD7859L has a number of calibration features that may be required in some applications, and there are a number of advantages in performing these different types of calibration. First, the internal errors in the ADC can be reduced significantly to give superior dc performance; and second, system offset and gain errors can be removed. This allows the user to remove reference errors (whether it be internal or external reference) and to make use of the full dynamic range of the AD7859/AD7859L by adjusting the analog input range of the part for a specific system.

There are two main calibration modes on the AD7859/AD7859L, self-calibration and system calibration. There are various options in both self-calibration and system calibration as outlined previously in Table IV. All the calibration functions are initiated by writing to the control register and setting the STCAL bit to 1.

The duration of each of the different types of calibration is given in Table IX for the AD7859 with a 4 MHz master clock. These calibration times are master clock dependent. Therefore the calibration times for the AD7859L (CLKIN = 1.8 MHz) are larger than those quoted in Table IX.

Table IX. Calibration Times (AD7859 with 4 MHz CLKIN)

Type of Self-Calibration or System Calibration	Time
Full	31.25 ms
Gain + Offset	6.94 ms
Offset	3.47 ms
Gain	3.47 ms

Calibration on Power-On

The calibration on power-on is initiated by the first $\overline{\text{CONVST}}$ pulse after the AV_{DD} and DV_{DD} power on. From the $\overline{\text{CONVST}}$ pulse the part internally sets a 32/72 ms (4 MHz/1.8 MHz CLKIN) timeout. This time is large enough to ensure that the internal reference has settled before the calibration is performed. However, if an external reference is being used, this reference must have stabilized before the automatic calibration is initiated. This first $\overline{\text{CONVST}}$ pulse also triggers the BUSY signal high, and once the 32/72 ms has elapsed, the BUSY signal goes low. At this point the next $\overline{\text{CONVST}}$ pulse that is applied initiates the automatic full self-calibration. This $\overline{\text{CONVST}}$ pulse again triggers the BUSY signal high, and after 32/72 ms (4 MHz/1.8 MHz CLKIN), the calibration is completed and the BUSY signal goes low. This timing arrangement is shown in Figure 28. The times in Figure 28 assume a 4 MHz/1.8 MHz CLKIN signal.

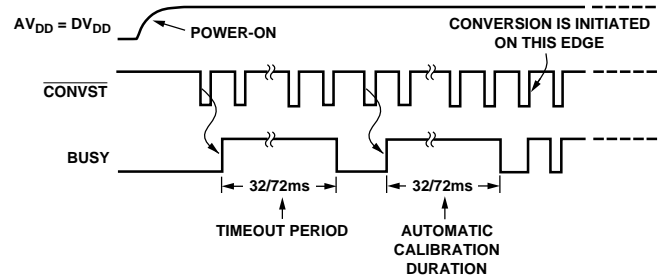

Figure 28. Timing Arrangement for Autocalibration on Power-On

The $\overline{\text{CONVST}}$ signal is gated with the BUSY internally so that as soon as the timeout is initiated by the first $\overline{\text{CONVST}}$ pulse all subsequent $\overline{\text{CONVST}}$ pulses are ignored until the BUSY signal goes low, 32/72 ms later. The $\overline{\text{CONVST}}$ pulse that follows after the BUSY signal goes low initiates a full self-calibration. This takes a further 32/72 ms. After calibration, the part is accurate to the 12-bit level and the specifications quoted on the data sheet apply; all subsequent $\overline{\text{CONVST}}$ pulses initiate conversions. There is no need to perform another calibration unless the operating conditions change or unless a system calibration is required.

This autocalibration at power-on is disabled if the user writes to the control register before the autocalibration is initiated. If the control register write operation occurs during the first 32/72 ms timeout period, then the BUSY signal stays high for the 32/72 ms and the $\overline{\text{CONVST}}$ pulse that follows the BUSY going low does not initiate a full self-calibration. It initiates a conversion and all subsequent $\overline{\text{CONVST}}$ pulses initiate conversions as well. If the control register write operation occurs when the automatic full self-calibration is in progress, then the calibration is not be aborted; the BUSY signal remains high until the automatic full self-calibration is complete.

Self-Calibration Description

There are four different calibration options within the self-calibration mode. There is a full self-calibration where the DAC, internal offset, and internal gain errors are removed. There is the (Gain + Offset) self-calibration which removes the internal gain error and then the internal offset errors. The internal DAC is not calibrated here. Finally, there are the self-offset and self-gain calibrations which remove the internal offset errors and the internal gain errors respectively.

The internal capacitor DAC is calibrated by trimming each of the capacitors in the DAC. It is the ratio of these capacitors to each other that is critical, and so the calibration algorithm ensures that this ratio is at a specific value by the end of the calibration routine. For the offset and gain there are two separate capacitors, one of which is trimmed during offset calibration and one of which is trimmed during gain calibration.

In Bipolar Mode the midscale error is adjusted by an offset calibration and the positive full-scale error is adjusted by the gain calibration. In Unipolar Mode the zero-scale error is adjusted by the offset calibration and the positive full-scale error is adjusted by the gain calibration.

AD7859/AD7859L

Self-Calibration Timing

Figure 29 shows the timing for a software full self-calibration. Here the BUSY line stays high for the full length of the self-calibration. A self-calibration is initiated by writing to the control register and setting the STCAL bit to 1. The BUSY line goes high at the end of the write to the control register, and BUSY goes low when the full self-calibration is complete after a time t_{CAL} as show in Figure 29.

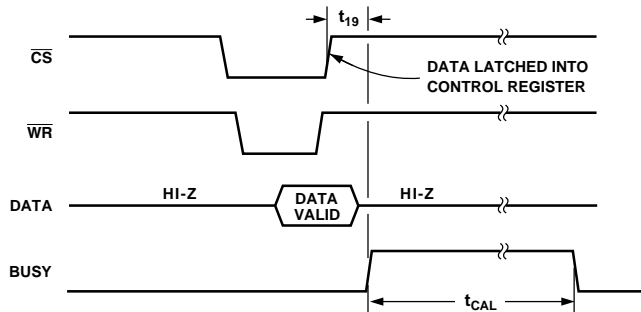

Figure 29. Timing Diagram for Full Self-Calibration

For the self-(gain + offset), self-offset and self-gain calibrations, the BUSY line is triggered high at the end of the write to the control register and stays high for the full duration of the self-calibration. The length of time for which BUSY is high depends on the type of self-calibration that is initiated. Typical values are given in Table IX. The timing diagram for the other self-calibration options is similar to that outlined in Figure 29.

System Calibration Description

System calibration allows the user to remove system errors external to the AD7859/AD7859L, as well as remove the errors of the AD7859/AD7859L itself. The maximum calibration range for the system offset errors is $\pm 5\%$ of V_{REF} and for the system gain errors, it is $\pm 2.5\%$ of V_{REF} . If the system offset or system gain errors are outside these ranges, the system calibration algorithm reduces the errors as much as the trim range allows.

Figures 30 through 32 illustrate why a specific type of system calibration might be used. Figure 30 shows a system offset calibration (assuming a positive offset) where the analog input range has been shifted upwards by the system offset after the system offset calibration is completed. A negative offset may also be removed by a system offset calibration.

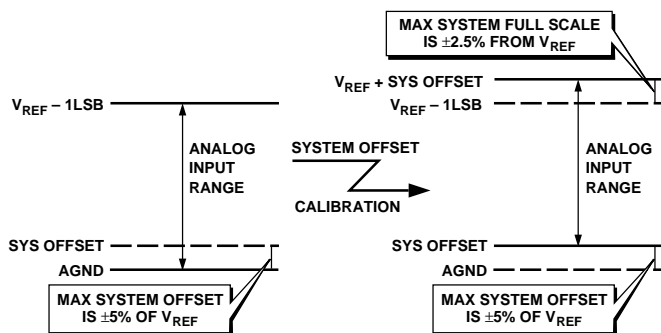

Figure 30. System Offset Calibration

Figure 31 shows a system gain calibration (assuming a system full scale greater than the reference voltage) where the analog input range has been increased after the system gain calibration is completed. A system full-scale voltage less than the reference voltage may also be accounted for by a system gain calibration.

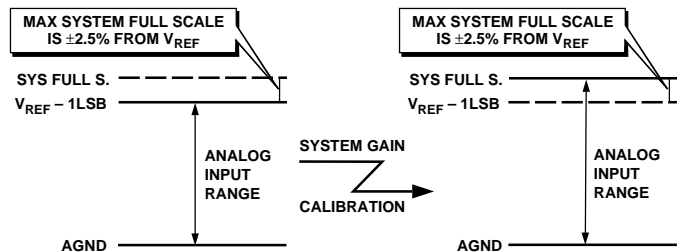

Figure 31. System Gain Calibration

Finally in Figure 32 both the system offset error and gain error are removed by the system offset followed by a system gain calibration. First the analog input range is shifted upwards by the positive system offset and then the analog input range is adjusted at the top end to account for the system full scale.

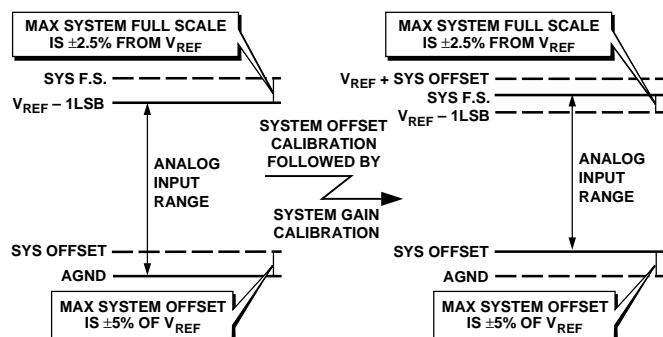

Figure 32. System (Gain + Offset) Calibration

System Gain and Offset Interaction

The architecture of the AD7859/AD7859L leads to an interaction between the system offset and gain errors when a system calibration is performed. Therefore, it is recommended to perform the cycle of a system offset calibration followed by a system gain calibration twice. When a system offset calibration is performed, the system offset error is reduced to zero. If this is followed by a system gain calibration, then the system gain error is now zero, but the system offset error is no longer zero. A second sequence of system offset error calibration followed by a system gain calibration is necessary to reduce system offset error to below the 12-bit level. The advantage of doing separate system offset and system gain calibrations is that the user has more control over when the analog inputs need to be at the required levels, and the $\overline{\text{CONVST}}$ signal does not have to be used.

Alternatively, a system (gain + offset) calibration can be performed. At the end of one system (gain + offset) calibration, the system offset error is zero, while the system gain error is reduced from its initial value. Three system (gain + offset) calibrations are required to reduce the system gain error to below the 12-bit error level. There is never any need to perform more than three system (gain + offset) calibrations.

In bipolar mode the midscale error is adjusted for an offset calibration and the positive full-scale error is adjusted for the gain calibration; in unipolar mode the zero-scale error is adjusted for an offset calibration and the positive full-scale error is adjusted for a gain calibration.

System Calibration Timing

The timing diagram in Figure 33 is for a software full system calibration. It may be easier in some applications to perform separate gain and offset calibrations so that the $\overline{\text{CONVST}}$ bit in the control register does not have to be programmed in the middle of the system calibration sequence. Once the write to the control register setting the bits for a full system calibration is completed, calibration of the internal DAC is initiated and the $\overline{\text{BUSY}}$ line goes high. The full-scale system voltage should be applied to the analog input pins, $\text{AIN}(+)$ and $\text{AIN}(-)$ at the start of calibration. The $\overline{\text{BUSY}}$ line goes low once the DAC and system gain calibration are complete. Next the system offset voltage should be applied across the $\text{AIN}(+)$ and $\text{AIN}(-)$ pins for a minimum setup time (t_{SETUP}) of 100 ns before the rising edge of $\overline{\text{CS}}$. This second write to the control register sets the $\overline{\text{CONVST}}$ bit to 1 and at the end of this write operation the $\overline{\text{BUSY}}$ signal is triggered high (note that a $\overline{\text{CONVST}}$ pulse can be applied instead of this second write to the control register). The $\overline{\text{BUSY}}$ signal is low after a time t_{CAL2} when the system offset calibration section is complete. The full system calibration is now complete.

The timing for a system (gain + offset) calibration is very similar to that of Figure 33, the only difference being that the time t_{CAL1} is replaced by a shorter time of the order of t_{CAL2} as the internal DAC is not calibrated. The $\overline{\text{BUSY}}$ signal signifies when the gain calibration is finished and when the part is ready for the offset calibration.

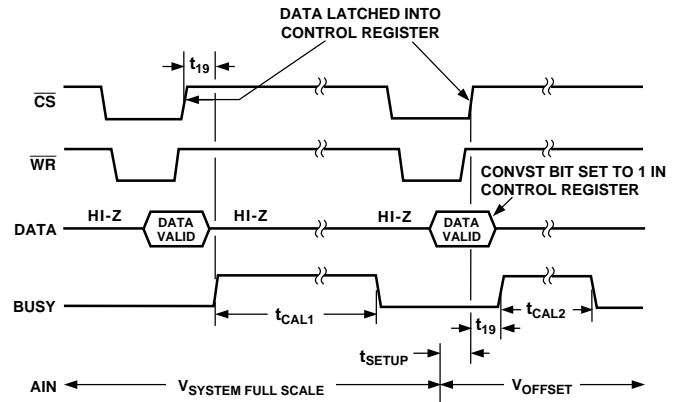

Figure 33. Timing Diagram for Full System Calibration

The timing diagram for a system offset or system gain calibration is shown in Figure 34. Here again a write to the control register initiates the calibration sequence. At the end of the control register write operation the $\overline{\text{BUSY}}$ line goes high and it stays high until the calibration sequence is finished. The analog input should be set at the correct level for a minimum setup time (t_{SETUP}) of 100 ns before the $\overline{\text{CS}}$ rising edge and stay at the correct level until the $\overline{\text{BUSY}}$ signal goes low.

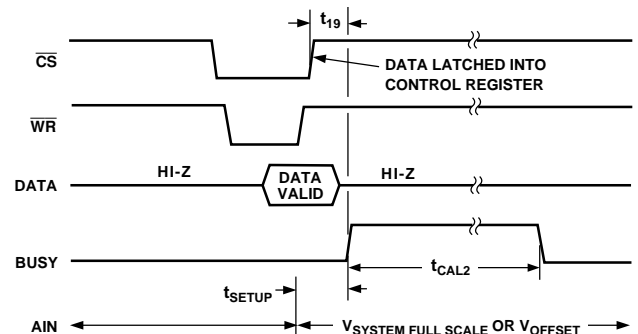

Figure 34. Timing Diagram for System Gain or System Offset Calibration

AD7859/AD7859L

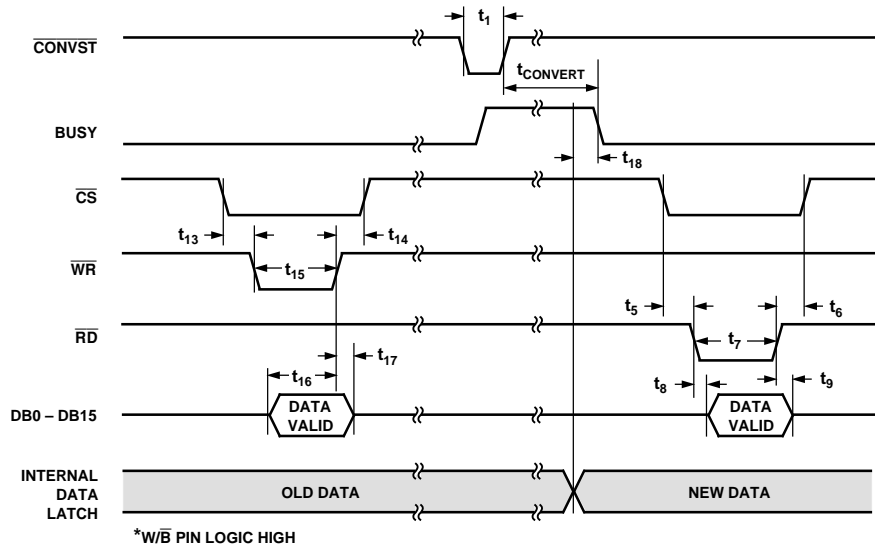

Figure 35. Read and Write Cycle Timing Diagram for 16-Bit Transfers

PARALLEL INTERFACE

The AD7859 provides a flexible, high speed, parallel interface. This interface is capable of operating in either word (with the W/B pin tied high) or byte (with W/B tied low) mode. A detailed description of the different interface arrangements follows.

Reading

With the W/B pin at a logic high, the AD7859 interface operates in word mode. In this case, a single read operation from the device accesses the word on pins DB0 to DB15 (for a data read, the 12-bit conversion result appears on DB0–DB11). DB0 is the LSB of the word. The DB8/HBEN pin assumes its DB8 function. With the W/B pin at a logic low, the AD7859 interface operates in byte mode. In this case, the DB8/HBEN pin assumes its HBEN function. Data to be accessed from the AD7859 must be accessed in two read operations with 8 bits of data provided by the AD7859 on DB0–DB7 for each of the read operations. The HBEN pin determines whether the read operation accesses the high byte or low byte of the 16-bit word. For a low byte read, DB0 provides the LSB of the 16-bit word. For a high byte read DB0 provides data bit 8 of the 16-bit word with DB7 providing the MSB of the 16-bit word.

Figure 35 shows the read cycle timing diagram for 16-bit transfers for the AD7859. When operated in word mode, the HBEN input does not exist, and only the first read operation is required to access data from the AD7859. Valid data, in this case, is provided on DB0–DB15. When operated in byte mode, the two read cycles shown in Figure 36 are required to access the full data word from the AD7859. Note that in byte mode, the order of successive read operations is important when reading the calibration registers. This is because the register file address pointer is incremented on a high byte read as explained in the calibration register section of this data sheet. In this case the order of the read should always be Low Byte–High Byte. In Figure 36, the first read places the lower 8 bits of the full data word on DB0–DB7 and the second read places the upper 8 bits of the data word on DB0–DB7.

The CS and RD signals are gated internally and level-triggered active low. In either word or byte mode, CS and RD may be tied together as the timing specification for t_5 and t_6 is 0 ns min. The data is output a time t_8 after both CS and RD go low. The RD rising should be used to latch data by the user and after a time t_9 the data lines will become three-stated.

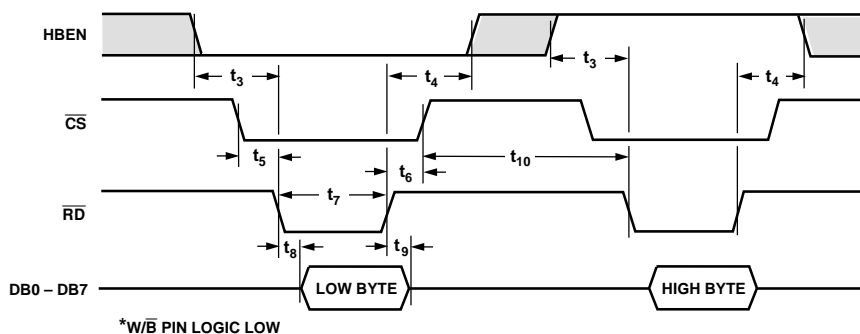

Figure 36. Read Cycle Timing for Byte Mode Operation

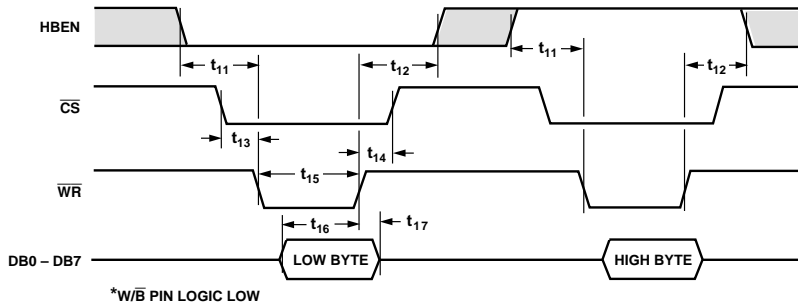

Figure 37. Write Cycle Timing for Byte Mode Operation

Writing

With $\overline{W/B}$ at a logic high, a single write operation transfers the full data word to the AD7859. The DB8/HBEN pin assumes its DB8 function. Data to be written to the AD7859 should be provided on the DB0–DB15 inputs with DB0 the LSB of the data word. With $\overline{W/B}$ at a logic low, the AD7859 requires two write operations to transfer a full 16-bit word. DB8/HBEN assumes its HBEN function. Data to be written to the AD7859 should be provided on the DB0–DB7 inputs. HBEN determines whether the byte which is to be written is high byte or low byte data. The low byte of the data word should be written first with DB0 the LSB of the full data word. For the high byte write, HBEN should be high and the data on the DB0 input should be data bit 8 of the 16-bit word with the data on DB7 the MSB of the 16-bit word.

Figure 35 shows the write cycle timing diagram for the AD7859. When operated in word mode, the HBEN input does not exist and only the first write operation is required to write data to the AD7859. Data should be provided on DB0–DB15. When operated in byte mode, the two write cycles shown in Figure 37 are required to write the full data word to the AD7859. In Figure 37, the first write transfers the lower 8 bits of the full data from DB0–DB7 and the second write transfers the upper 8 bits of the data word from DB0–DB7.

The \overline{CS} and \overline{WR} signals are gated internally. \overline{CS} and \overline{WR} may be tied together as the timing specification for t_{13} and t_{14} is 0 ns min. The data is latched on the rising edge of \overline{WR} . The data needs to be set up a time t_{16} before the \overline{WR} rising edge and held for a time t_{17} after the \overline{WR} rising edge.

Resetting the Parallel Interface

In the case where incorrect data is inadvertently written to the AD7859, there is a possibility that the Test Register contents may have been altered. If there is a suspicion that this may have happened and the part is not operating as expected, a 16-bit word 0000 0000 0000 0010 should be written to the AD7859 to restore the Test Register contents to the default value.

MICROPROCESSOR INTERFACING

Interfacing the AD7859/AD7859L to a 16-Bit Data Bus

The parallel port on the AD7859 allows the device to be interfaced to microprocessors or DSP processors as a memory-mapped or I/O-mapped device. The \overline{CS} and \overline{RD} inputs are common to all memory peripheral interfacing. Typical interfaces to different processors are shown in Figures 38 to 42. In all the interfaces shown, an external timer controls the \overline{CONVST} input of the AD7859/AD7859L, the BUSY output interrupts the host DSP and the $\overline{W/B}$ input is logic high.

AD7859/AD7859L to ADSP-21xx

Figure 38 shows the AD7859/AD7859L interfaced to the ADSP-21xx series of DSPs as a memory mapped device. A single wait state may be necessary to interface the AD7859/AD7859L to the ADSP-21xx depending on the clock speed of the DSP. This wait state can be programmed via the Data Memory Waitstate Control Register of the ADSP-21xx (please see *ADSP-2100 Family Users Manual* for details). The following instruction reads data from the AD7859/AD7859L:

$$MR = DM(ADC)$$

where *ADC* is the address of the AD7859/AD7859L.

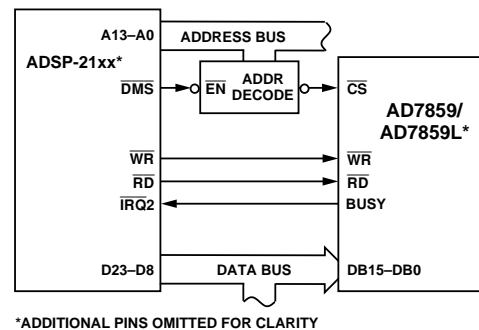

*ADDITIONAL PINS OMITTED FOR CLARITY

Figure 38. AD7859/AD7859L to ADSP-21xx Parallel Interface

AD7859/AD7859L to TMS32020, TMS320C25 and TMS320C5x

Parallel interfaces between the AD7859/AD7859L and the TMS32020, TMS320C25 and TMS320C5x family of DSPs are shown in Figure 39. The memory mapped address chosen for the AD7859/AD7859L should be chosen to fall in the I/O memory space of the DSPs.

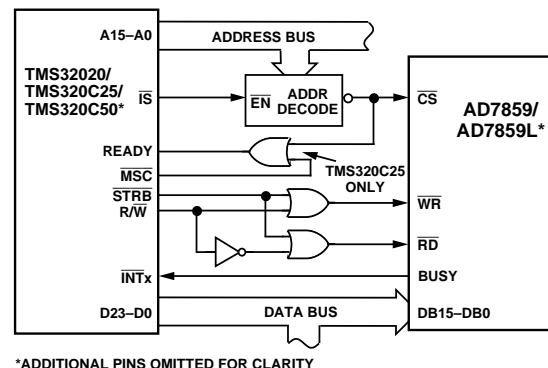

*ADDITIONAL PINS OMITTED FOR CLARITY

Figure 39. AD7859/AD7859L to TMS32020/C25/C5x Parallel Interface

AD7859/AD7859L

The parallel interface on the AD7859/AD7859L is fast enough to interface to the TMS32020 with no extra wait states. If high speed glue logic such as 74AS devices are used to drive the \overline{WR} and \overline{RD} lines when interfacing to the TMS320C25, then again no wait states are necessary. However, if slower logic is used, data accesses may be slowed sufficiently when reading from and writing to the part to require the insertion of one wait state. In such a case, this wait state can be generated using the single OR gate to combine the \overline{CS} and \overline{MSC} signals to drive the READY line of the TMS320C25, as shown in Figure 39. Extra wait states will be necessary when using the TMS320C5x at their fastest clock speeds. Wait states can be programmed via the IOWSR and CWSR registers (please see *TMS320C5x User Guide* for details).

Data is read from the ADC using the following instruction:

IN D,ADC

where *D* is the memory location where the data is to be stored and *ADC* is the I/O address of the AD7859/AD7859L.

AD7859/AD7859L to TMS320C30

Figure 40 shows a parallel interface between the AD7859/AD7859L and the TMS320C3x family of DSPs. The AD7859/AD7859L is interfaced to the Expansion Bus of the TMS320C3x. A single wait state is required in this interface. This can be programmed using the WTCNT bits of the Expansion Bus Control register (see *TMS320C3x Users Guide* for details). Data from the AD7859/AD7859L can be read using the following instruction:

*LDI *ARn,Rx*

where *ARn* is an auxiliary register containing the lower 16 bits of the address of the AD7859/AD7859L in the TMS320C3x memory space and *Rx* is the register into which the ADC data is loaded.

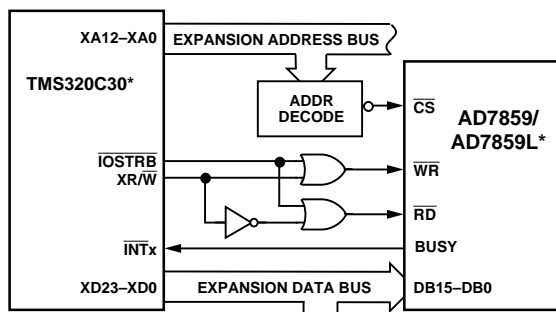

*ADDITIONAL PINS OMITTED FOR CLARITY

Figure 40. AD7859/AD7859L to TMS320C30 Parallel Interface

AD7859/AD7859L to DSP5600x

Figure 41 shows a parallel interface between the AD7859/AD7859L and the DSP5600x series of DSPs. The AD7859/AD7859L should be mapped into the top 64 locations of Y data memory. If extra wait states are needed in this interface, they can be programmed using the Port A Bus Control Register (please see *DSP5600x Users Manual* for details). Data can be read from the AD7859/AD7859L using the following instruction:

MOVEO Y:ADC,X0

where *ADC* is the address in the DSP5600x address space which the AD7859/AD7859L has been mapped to.

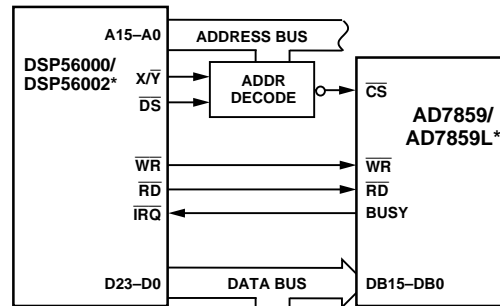

*ADDITIONAL PINS OMITTED FOR CLARITY

Figure 41. AD7859/AD7859L to DSP5600x Parallel Interface

Interfacing the AD7859/AD7859L to an 8-Bit Data Bus AD7859/AD7859L to 8051

This mode of operation allows the AD7859/AD7859L to be interfaced directly to microcontrollers with an 8-bit data bus. The AD7859/AD7859L is placed in byte mode by placing a logic low signal on the $\overline{W/B}$ pin.

Figure 42 shows a parallel interface between the AD7859/AD7859L and the 8051 microcontroller. Here the $\overline{W/B}$ pin is tied logic low and the DB8/HBEN pin connected to line 1 of Port 2. Port 0 serves as a multiplexed address/data bus to the AD7859/AD7859L. Alternatively if the 8051 is not using external memory or other memory mapped peripheral devices, line 2 of Port 2 (or any other line) could be used as the CS signal.

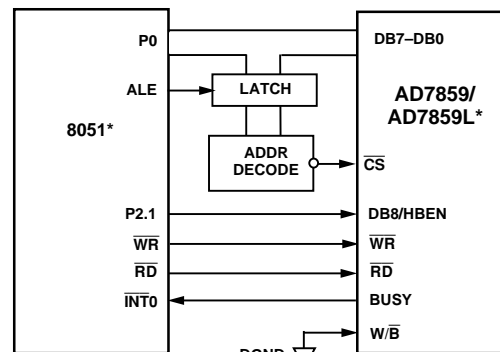

*ADDITIONAL PINS OMITTED FOR CLARITY

Figure 42. AD7859/AD7859L to 8051 Parallel Interface

APPLICATION HINTS

Grounding and Layout

The analog and digital supplies of the AD7859/AD7859L are independent and separately pinned out to minimize coupling between the analog and digital sections of the device. The part has very good immunity to noise on the power supplies as can be seen by the PSRR versus Frequency graph. However, care should still be taken with regard to grounding and layout.

The printed circuit board on which the AD7859/AD7859L is mounted should be designed such that the analog and digital sections are separated and confined to certain areas of the board. This facilitates the use of ground planes that can be easily separated. A minimum etch technique is generally best for ground planes as it gives the best shielding. Digital and analog ground planes should only be joined in one place. If the AD7859/AD7859L is the only device requiring an AGND to

DGND connection, then the ground planes should be connected at the AGND and DGND pins of the AD7859/AD7859L. If the AD7859/AD7859L is in a system where multiple devices require AGND to DGND connections, the connection should still be made at one point only, a star ground point which should be established as close as possible to the AD7859/AD7859L.

Avoid running digital lines under the device as these couple noise onto the die. The analog ground plane should be allowed to run under the AD7859/AD7859L to avoid noise coupling. The power supply lines to the AD7859/AD7859L should use as large a trace as possible to provide low impedance paths and reduce the effects of glitches on the power supply line. Fast switching signals like clocks and the data inputs should be shielded with digital ground to avoid radiating noise to other sections of the board and clock signals should never be run near the analog inputs. Avoid crossover of digital and analog signals. Traces on opposite sides of the board should run at right angles to each other. This reduces the effects of feedthrough through the board. A microstrip technique is by far the best but is not always possible with a double-sided board. In this technique, the component side of the board is dedicated to ground planes while signals are placed on the solder side.

Good decoupling is also important. All analog supplies should be decoupled with a 10 μF tantalum capacitor in parallel with 0.1 μF disc ceramic capacitor to AGND. All digital supplies should have a 0.1 μF disc ceramic capacitor to DGND. To achieve the best performance from these decoupling components, they must be placed as close as possible to the device, ideally right up against the device. In systems where a common supply voltage is used to drive both the AV_{DD} and DV_{DD} of the AD7859/AD7859L, it is recommended that the system's AV_{DD} supply is used. In this case an optional 10 Ω resistor between the AV_{DD} pin and DV_{DD} pin can help to filter noise from digital circuitry. This supply should have the recommended analog supply decoupling capacitors between the AV_{DD} pin of the AD7859/AD7859L and AGND and the recommended digital supply decoupling capacitor between the DV_{DD} pin of the AD7859/AD7859L and DGND.

Evaluating the AD7859/AD7859L Performance

The recommended layout for the AD7859/AD7859L is outlined in the evaluation board for the AD7859/AD7859L. The evaluation board package includes a fully assembled and tested evaluation board, documentation, and software for controlling the board from the PC via the EVAL-CONTROL BOARD. The EVAL-CONTROL BOARD can be used in conjunction with the AD7859/AD7859L Evaluation board, as well as many other Analog Devices evaluation boards ending in the CB designator, to demonstrate/evaluate the ac and dc performance of the AD7859/AD7859L.

The software allows the user to perform ac (fast Fourier transform) and dc (histogram of codes) tests on the AD7859/AD7859L. It also gives full access to all the AD7859/AD7859L on-chip registers allowing for various calibration and power-down options to be programmed.

AD785x Family

All parts are 12 bits, 200 kSPS, 3.0 V to 5.5 V.

AD7853 – Single-Channel Serial

AD7854 – Single-Channel Parallel

AD7858 – Eight-Channel Serial

AD7859 – Eight-Channel Parallel

PAGE INDEX

Topic	Page
FEATURES	1
GENERAL DESCRIPTION	1
PRODUCT HIGHLIGHTS	1
SPECIFICATIONS	2
TIMING SPECIFICATIONS	4
ABSOLUTE MAXIMUM RATINGS	5
ORDERING GUIDE	5
PINOUTS	5
TERMINOLOGY	6
PIN FUNCTION DESCRIPTION	7
AD7859/AD7859L ON-CHIP REGISTERS	8
Addressing the On-Chip Registers	8
Writing/Reading	8
CONTROL REGISTER	9
STATUS REGISTER	11
CALIBRATION REGISTERS	12
Addressing the Calibration Registers	12
Writing to/Reading from the Calibration Registers	12
Adjusting the Offset Calibration Register	13
Adjusting the Gain Calibration Registers	13
CIRCUIT INFORMATION	14
CONVERTER DETAILS	14
TYPICAL CONNECTION DIAGRAM	14
ANALOG INPUT	15
Acquisition Time	15
DC/AC Applications	15
Input Ranges	16
Transfer Functions	16
REFERENCE SECTION	17
AD7859/AD7859L PERFORMANCE CURVES	17
POWER-DOWN OPTIONS	18
POWER-UP TIMES	18
POWER VS. THROUGHPUT RATE	19
CALIBRATION SECTION	21
Calibration Overview	21
Calibration on Power-On	21
Self-Calibration Description	21
Self-Calibration Timing	22
System Calibration Description	22
System Gain and Offset Interaction	23
System Calibration Timing	23
PARALLEL INTERFACE	24
MICROPROCESSOR INTERFACING	25
APPLICATIONS HINTS	27
Grounding and Layout	27
Evaluating the AD7859/AD7859L Performance	27
INDEX	28
OUTLINE DIMENSIONS	28

OUTLINE DIMENSIONS

Dimensions shown in inches and (mm).

**44-Lead PLCC
(P-44A)**

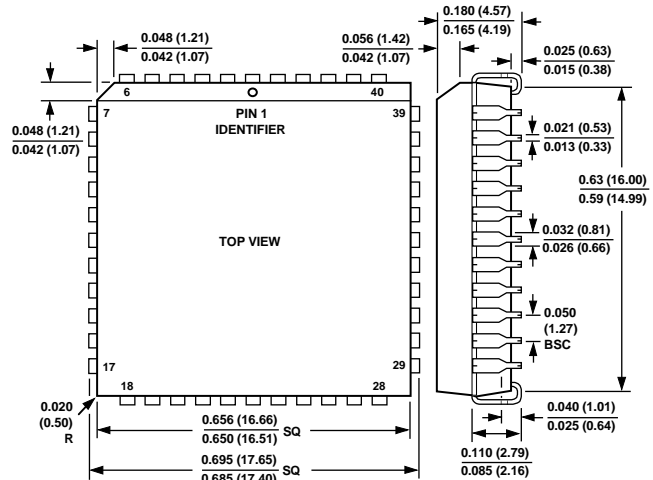

**44-Pin PQFP
(S-44)**

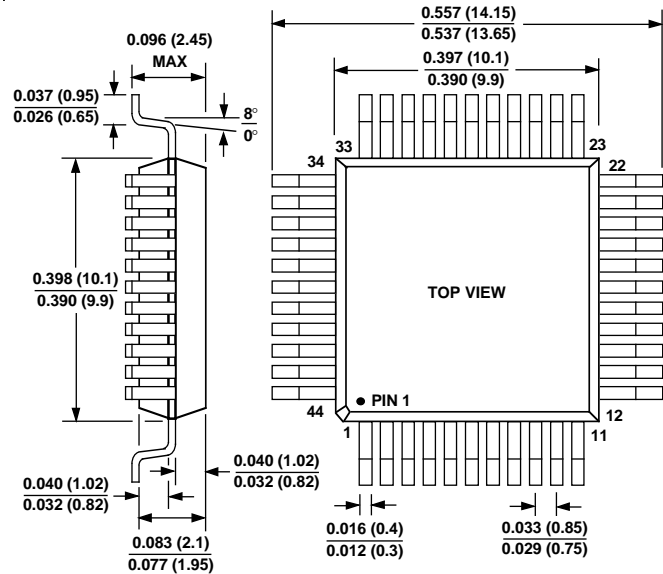

C2109-7-1/96

PRINTED IN U.S.A.

Компания «Life Electronics» занимается поставками электронных компонентов импортного и отечественного производства от производителей и со складов крупных дистрибьюторов Европы, Америки и Азии.

С конца 2013 года компания активно расширяет линейку поставок компонентов по направлению коаксиальный кабель, кварцевые генераторы и конденсаторы (керамические, пленочные, электролитические), за счёт заключения дистрибьюторских договоров

Мы предлагаем:

- Конкурентоспособные цены и скидки постоянным клиентам.
- Специальные условия для постоянных клиентов.
- Подбор аналогов.
- Поставку компонентов в любых объемах, удовлетворяющих вашим потребностям.
- Приемлемые сроки поставки, возможна ускоренная поставка.
- Доставку товара в любую точку России и стран СНГ.
- Комплексную поставку.
- Работу по проектам и поставку образцов.
- Формирование склада под заказчика.
- Сертификаты соответствия на поставляемую продукцию (по желанию клиента).
- Тестирование поставляемой продукции.
- Поставку компонентов, требующих военную и космическую приемку.
- Входной контроль качества.
- Наличие сертификата ISO.

В составе нашей компании организован Конструкторский отдел, призванный помогать разработчикам, и инженерам.

Конструкторский отдел помогает осуществить:

- Регистрацию проекта у производителя компонентов.
- Техническую поддержку проекта.
- Защиту от снятия компонента с производства.
- Оценку стоимости проекта по компонентам.
- Изготовление тестовой платы монтаж и пусконаладочные работы.



Тел: +7 (812) 336 43 04 (многоканальный)
Email: org@lifeelectronics.ru