

Quad channel high-side driver

Features

Type	$R_{DS(on)}$	I_{OUT}	V_{CC}
VNQ830E-E	65 m Ω ⁽¹⁾	9.5 A ⁽¹⁾	36 V

1. Per each channel.

- Output current: 9.5 A
- CMOS compatible inputs
- On-state open-load detection
- Off-state open-load detection
- Output stuck to V_{CC} detection
- Open drain status outputs
- Undervoltage shutdown
- Overvoltage clamp
- Thermal shutdown
- Current and power limitation
- Very low standby current
- Protection against loss of ground and loss of V_{CC}
- Reverse battery protection
- Very low electromagnetic susceptibility
- Optimized electromagnetic emission

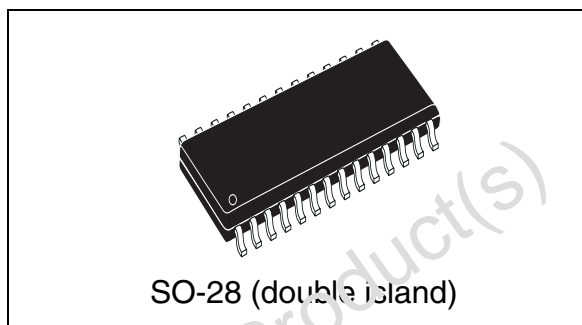

Description

The VNQ830E-E is a quad HSD formed by assembling two VND830E-E chips in the same SO-28 package. The VND830E-E is a monolithic device made using STMicroelectronics™ VIPower™ M0-3 technology.

It is intended for driving resistive or inductive loads with one side connected to ground. Active V_{CC} pin voltage clamp protects the device against low energy spikes (see ISO7637 transient compatibility table).

The device detects open-load condition both in on-state and off-state. Output shorted to V_{CC} is detected in the off-state. Output current limitation protects the device in overload condition. In case of long duration overload, the device limits the dissipated power to safe level up to thermal shutdown intervention. Thermal shutdown with automatic restart allows the device to recover normal operation as soon as fault condition disappears.

Table 1. Device summary

Package	Order codes	
	Tube	Tape and reel
SO-28	VNQ830E-E	VNQ830ETR-E

Contents

1	Block diagram and pin description	5
2	Electrical specifications	7
2.1	Absolute maximum ratings	7
2.2	Thermal data	8
2.3	Electrical characteristics	8
2.4	Electrical characteristics curves	15
3	Application information	18
3.1	GND protection network against reverse battery	18
3.1.1	Solution 1: a resistor in the ground line (R _{GND} only)	18
3.1.2	Solution 2: a diode (D _{GND}) in the ground line	19
3.2	Load dump protection	19
3.3	MCU I/O protection	19
3.4	Open-load detection in off state	20
3.5	Maximum demagnetization energy	21
4	Package and PCB thermal data	22
4.1	SO-28 thermal data	22
5	Package and packing information	25
5.1	ECOPACK® packages	25
5.2	SO-28 packing information	26
6	Revision history	27

List of tables

Table 1.	Device summary	1
Table 2.	Suggested connections for unused and not connected pins	6
Table 3.	Absolute maximum rating	7
Table 4.	Thermal data (per island)	8
Table 5.	Power output.	8
Table 6.	Switching (per each channel) ($V_{CC} = 13\text{ V}$)	9
Table 7.	V_{CC} - output diode	9
Table 8.	Status pin (per each channel).	10
Table 9.	Protections (per each channel).	10
Table 10.	Logic input (per each channel)	10
Table 11.	Open-load detection (per each channel)	11
Table 12.	Truth table.	12
Table 13.	Electrical transient requirements on V_{CC} pin (part 1)	13
Table 14.	Electrical transient requirements on V_{CC} pin (part 2)	13
Table 15.	Electrical transient requirements on V_{CC} pin (part 3)	13
Table 16.	Thermal calculation according to the PCB heatsink area	22
Table 17.	Thermal parameters	24
Table 18.	SO-28 mechanical data	25
Table 19.	Document revision history	27

List of figures

Figure 1.	Block diagram	5
Figure 2.	Configuration diagram (top view)	6
Figure 3.	Current and voltage conventions	8
Figure 4.	Status timings	11
Figure 5.	Switching time waveforms	11
Figure 6.	Waveforms	14
Figure 7.	Off-state output current	15
Figure 8.	High level input current	15
Figure 9.	Input clamp voltage	15
Figure 10.	Status leakage current	15
Figure 11.	Status low output voltage	15
Figure 12.	Status clamp voltage	15
Figure 13.	On-state resistance vs T_{case}	16
Figure 14.	On-state resistance vs V_{CC}	16
Figure 15.	Open-load on-state detection threshold	16
Figure 16.	Open-load off-state detection threshold	16
Figure 17.	Input high level	16
Figure 18.	Input low level	16
Figure 19.	Input hysteresis voltage	17
Figure 20.	Overshoot shutdown	17
Figure 21.	Turn-on voltage slope	17
Figure 22.	Turn-off voltage slope	17
Figure 23.	I_{LIM} vs T_{case}	17
Figure 24.	Undervoltage shutdown	17
Figure 25.	Application schematic	18
Figure 26.	Open-load detection in off-state	20
Figure 27.	Maximum turn-off current versus load inductance	21
Figure 28.	SO-28 PC board	22
Figure 29.	$R_{thj-amb}$ vs PCB copper area in open box free air condition	23
Figure 30.	SP-28 thermal impedance junction ambient single pulse	23
Figure 31.	Thermal fitting model of a quad channel HSD in SO-28	24
Figure 32.	SO-28 package dimensions	25
Figure 33.	SO-28 tube shipment (no suffix)	26
Figure 34.	SO-28 tape and reel shipment (suffix "13TR")	26

1 Block diagram and pin description

Figure 1. Block diagram

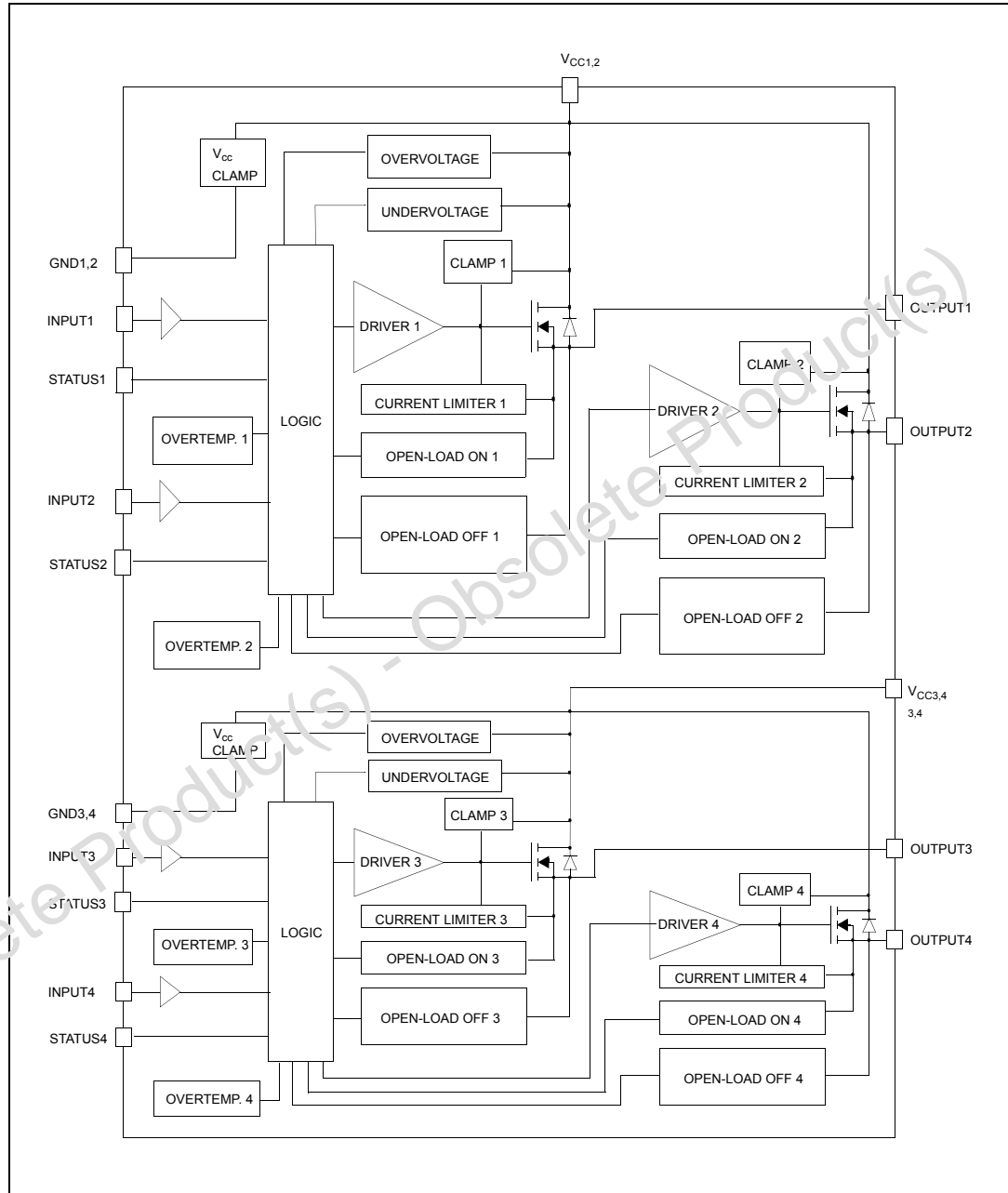

Figure 2. Configuration diagram (top view)

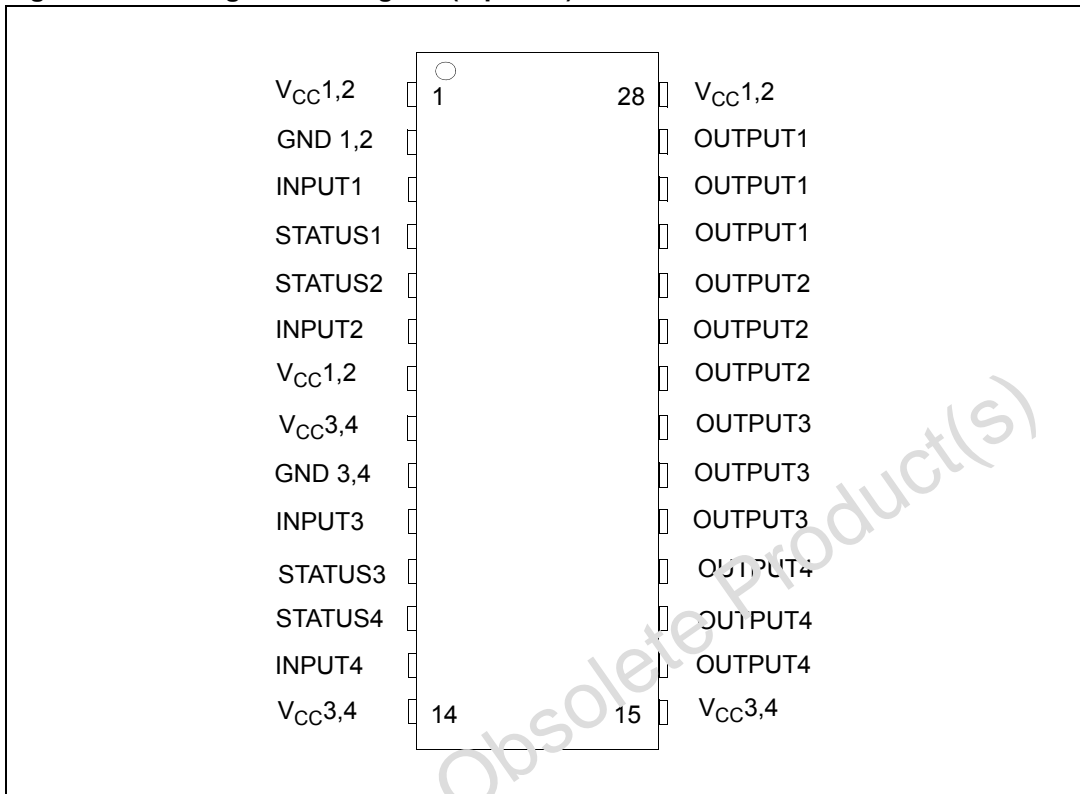

Table 2. Suggested connections for unused and not connected pins

Connection / pin	Status	N.C.	Output	Input
Floating	X	X	X	X
To ground		X		Through 10 K Ω resistor

2 Electrical specifications

2.1 Absolute maximum ratings

Stressing the device above the rating listed in [Table 3](#) may cause permanent damage to the device. These are stress ratings only and operation of the device at these or any other conditions above those indicated in the operating sections of this specification is not implied. Exposure to Absolute Maximum Rating conditions for extended periods may affect device reliability. Refer also to the STMicroelectronics SURE Program and other relevant quality document.

Table 3. Absolute maximum rating

Symbol	Parameter	Value	Unit
V_{CC}	DC supply voltage	41	V
$-V_{CC}$	Reverse DC supply voltage	-0.3	V
$-I_{GND}$	DC reverse ground pin current	-200	mA
I_{OUT}	DC output current	Internally limited	A
$-I_{OUT}$	Reverse DC output current	-6	A
I_{IN}	DC input current	+/-10	mA
I_{STAT}	DC status current	+/-10	mA
V_{ESD}	Electrostatic discharge (Human Body Model: $R=1.5\text{ K}\Omega$; $C=100\text{ pF}$)		
	- INPUT	4000	V
	- STATUS	4000	V
	- OUTPUT	5000	V
	$-V_{CC}$	5000	V
E_{MAX}	Maximum switching energy $L = 0.5\text{ mH}$; $R_L = 0\ \Omega$; $V_{bat} = 13.5\text{ V}$; $T_{jstart} = 150\text{ }^\circ\text{C}$; $I_L = 13.5\text{ A}$)	64	mJ
P_{tot}	Power dissipation (per island) at $T_{lead} = 25\text{ }^\circ\text{C}$	6.25	W
T_j	Junction operating temperature	Internally limited	$^\circ\text{C}$
T_c	Case operating temperature	- 40 to 150	$^\circ\text{C}$
T_{stg}	Storage temperature	- 55 to 150	$^\circ\text{C}$

2.2 Thermal data

Table 4. Thermal data (per island)

Symbol	Parameter	Value		Unit
$R_{thj-lead}$	Thermal resistance junction-lead per chip	20		°C/W
$R_{thj-amb}$	Thermal resistance junction-ambient (one chip ON)	60 ⁽¹⁾	45 ⁽²⁾	°C/W
$R_{thj-amb}$	Thermal resistance junction-ambient (two chips ON)	46 ⁽¹⁾	30 ⁽²⁾	°C/W

1. When mounted on a standard single-sided FR-4 board with 0.5 cm² of Cu (at least 35 μm thick) connected to all V_{CC} pins. Horizontal mounting and no artificial air flow.
2. When mounted on a standard single-sided FR-4 board with 6 cm² of Cu (at least 35 μm thick) connected to all V_{CC} pins. Horizontal mounting and no artificial air flow.

2.3 Electrical characteristics

Values specified in this section are for 8 V < V_{CC} < 36 V; -40 °C < T_j < 150 °C, unless otherwise stated.

(Per each channel)

Figure 3. Current and voltage conventions

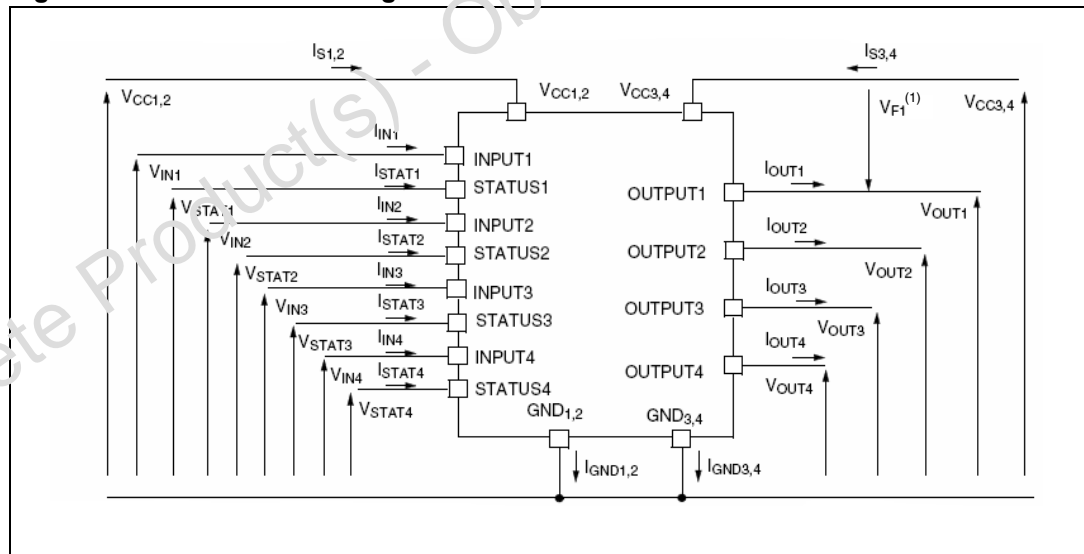

1. $V_{Fn} = V_{CCn} - V_{OUTn}$ during reverse battery condition.

Table 5. Power output

Symbol	Parameter	Test conditions	Min.	Typ.	Max.	Unit
$V_{CC}^{(1)}$	Operating supply voltage		5.5	13	36	V
$V_{USD}^{(1)}$	Undervoltage shutdown		3	4	5.5	V
$V_{OV}^{(1)}$	Overvoltage shutdown		36			V

Table 5. Power output (continued)

Symbol	Parameter	Test conditions	Min.	Typ.	Max.	Unit
R_{ON}	On-state resistance	$I_{OUT} = 2 \text{ A}; T_j = 25 \text{ }^\circ\text{C}$ $I_{OUT} = 2 \text{ A}; V_{CC} > 8 \text{ V}$			65 130	$\text{m}\Omega$ $\text{m}\Omega$
$I_S^{(1)}$	Supply current	Off-state; $V_{CC} = 13 \text{ V};$ $V_{IN} = V_{OUT} = 0 \text{ V}$		12	40	μA
		Off-state; $V_{CC} = 13 \text{ V};$ $V_{IN} = V_{OUT} = 0 \text{ V};$ $T_j = 25^\circ\text{C}$		12	25	μA
		On-state; $V_{CC} = 13 \text{ V}; V_{IN} = 5 \text{ V};$ $I_{OUT} = 0 \text{ A}$		5	7	nA
$I_{L(off1)}$	Off-state output current	$V_{IN} = V_{OUT} = 0 \text{ V}$	0		50	μA
$I_{L(off2)}$	Off-state output current	$V_{IN} = 0 \text{ V}; V_{OUT} = 3.5 \text{ V}$	75		0	μA
$I_{L(off3)}$	Off-state output current	$V_{IN} = V_{OUT} = 0 \text{ V}; V_{CC} = 13 \text{ V};$ $T_j = 125 \text{ }^\circ\text{C}$			5	μA
$I_{L(off4)}$	Off-state output current	$V_{IN} = V_{OUT} = 0 \text{ V}; V_{CC} = 13 \text{ V};$ $T_j = 25 \text{ }^\circ\text{C}$			3	μA

1. Per island.

Table 6. Switching (per each channel) ($V_{CC} = 13 \text{ V}$)

Symbol	Parameter	Test conditions	Min.	Typ.	Max.	Unit
$t_{d(on)}$	Turn-on delay time	$R_L = 6.5 \text{ }\Omega$ from V_{IN} rising edge to $V_{OUT} = 1.3 \text{ V}$	-	50	-	μs
$t_{d(off)}$	Turn-off delay time	$R_L = 6.5 \text{ }\Omega$ from V_{IN} falling edge to $V_{OUT} = 11.7 \text{ V}$	-	50	-	μs
$dV_{OUT}/dt_{(on)}$	Turn-on voltage slope	$R_L = 6.5 \text{ }\Omega$ from $V_{OUT} = 1.3 \text{ V}$ to $V_{OUT} = 10.4 \text{ V}$	-	See Figure 21	-	$\text{V}/\mu\text{s}$
$dV_{OUT}/dt_{(off)}$	Turn-off voltage slope	$R_L = 6.5 \text{ }\Omega$ from $V_{OUT} = 11.7 \text{ V}$ to $V_{OUT} = 1.3 \text{ V}$	-	See Figure 22	-	$\text{V}/\mu\text{s}$

Table 7. V_{CC} - output diode

Symbol	Parameter	Test conditions	Min.	Typ.	Max.	Unit
V_F	Forward on voltage	$I_{OUT} = 1.2 \text{ A}; T_j = 150 \text{ }^\circ\text{C}$	-	-	0.6	V

Table 8. Status pin (per each channel)

Symbol	Parameter	Test conditions	Min.	Typ.	Max.	Unit
V _{STAT}	Status low output voltage	I _{STAT} = 1.6 mA			0.5	V
I _{LSTAT}	Status leakage current	Normal operation; V _{STAT} = 5 V			10	μA
C _{STAT}	Status pin input capacitance	Normal operation; V _{STAT} = 5 V			100	pF
V _{SCL}	Status clamp voltage	I _{STAT} = 1 mA I _{STAT} = -1 mA	6	6.8 - 0.7	8	V V

Table 9. Protections (per each channel)⁽¹⁾

Symbol	Parameter	Test conditions	Min.	Typ.	Max.	Unit
T _{TSD}	Shutdown temperature		150	175	200	°C
T _R	Reset temperature		135			°C
T _{hyst}	Thermal hysteresis		7	15		°C
t _{SDL}	Status delay in overload conditions	T _j > T _{TSD}			20	μs
I _{lim}	Current limitation	V _{CC} = 13 V 5.5 V < V _{CC} < 36 V	9.5	13.5	18 18	A A
V _{demag}	Turn-off output clamp voltage	I _{OUT} = 2 A; L = 6 mH	V _{CC} -41	V _{CC} -48	V _{CC} -55	V

1. To ensure long term reliability, under heavy overload or short circuit conditions, protection and related diagnostic signals must be used together with a proper software strategy. If the device is subjected to abnormal conditions, this software must limit the duration and number of activation cycles.

Table 10. Logic input (per each channel)

Symbol	Parameter	Test conditions	Min.	Typ.	Max.	Unit
V _{IL}	Low level input voltage				1.25	V
V _{IH}	High level input voltage		3.25			V
V _{I(hyst)}	Input hysteresis voltage		0.5			V
I _{IL}	Low level input current	V _{IN} = 1.5 V	1			μA
I _{IH}	High level input current	V _{IN} = 3.25 V			10	μA
V _{ICL}	Input clamp voltage	I _{IN} = 1 mA I _{IN} = -1 mA	6	6.8 - 0.7	8	V V

Table 11. Open-load detection (per each channel)

Symbol	Parameter	Test conditions	Min.	Typ.	Max.	Unit
I_{OL}	Open-load on-state detection threshold	$V_{IN} = 5\text{ V}$	50	115	200	mA
$t_{DOL(on)}$	Open-load on-state detection delay	$I_{OUT} = 0\text{ A}$			200	μs
V_{OL}	Open-load off-state voltage detection threshold	$V_{IN} = 0\text{ V}$	1.5	2.9	3.5	V
$t_{DOL(off)}$	Open-load detection delay at turn-off				1000	μs

Figure 4. Status timings

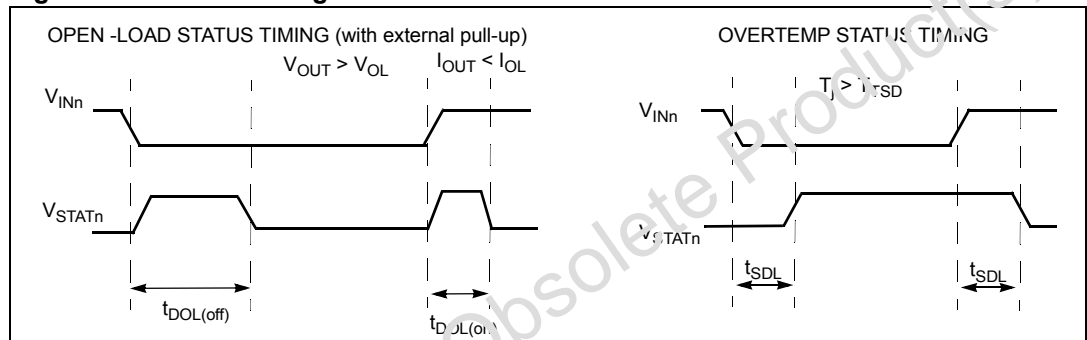

Figure 5. Switching time waveforms

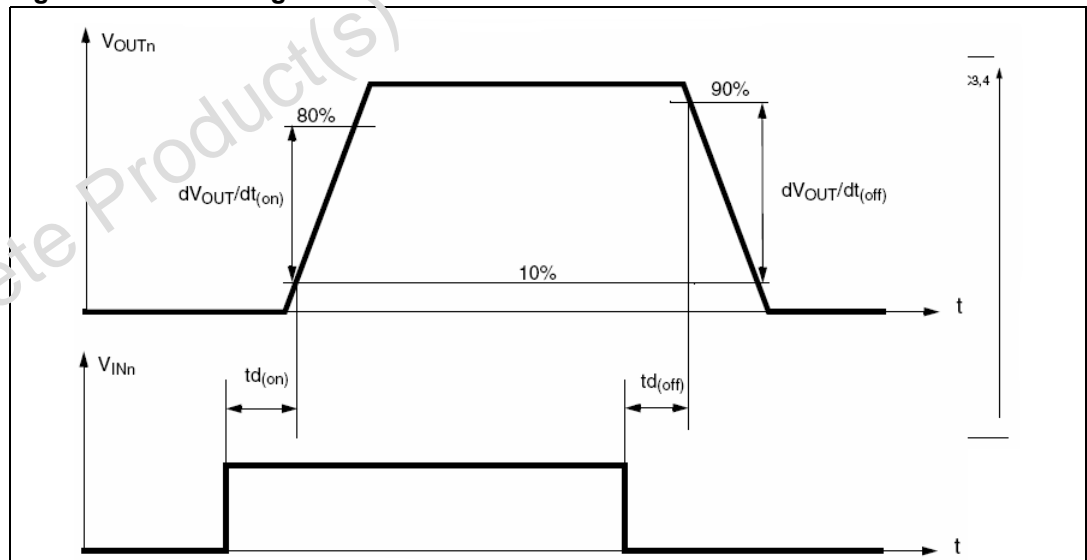

Table 12. Truth table

Conditions	Input	Output	Status
Normal operation	L	L	H
	H	H	H
Current limitation	L	L	H
	H	X	($T_j < T_{TSD}$) H
	H	X	($T_j > T_{TSD}$) L
Overtemperature	L	L	H
	H	L	L
Undervoltage	L	L	X
	H	L	X
Overvoltage	L	L	H
	H	L	H
Output voltage $> V_{OL}$	L	H	L
	H	H	H
Output current $< I_{OL}$	L	L	H
	H	H	L

Table 13. Electrical transient requirements on V_{CC} pin (part 1)

ISO T/R 7637/1 Test pulse	Test levels				Delays and impedance
	I	II	III	IV	
1	- 25 V	- 50 V	- 75 V	- 100 V	2 ms, 10 Ω
2	+ 25 V	+ 50 V	+ 75 V	+ 100 V	0.2 ms, 10 Ω
3a	- 25 V	- 50 V	- 100 V	- 150 V	0.1 μs, 50 Ω
3b	+ 25 V	+ 50 V	+ 75 V	+ 100 V	0.1 μs, 50 Ω
4	- 4 V	- 5 V	- 6 V	- 7 V	100 ms, 0.01 Ω
5	+ 26.5 V	+ 46.5 V	+ 66.5 V	+ 86.5 V	400 ms, 2 Ω

Table 14. Electrical transient requirements on V_{CC} pin (part 2)

ISO T/R 7637/1 Test pulse	Test levels results			
	I	II	III	IV
1	C	C	C	C
2	C	C	C	C
3a	C	C	C	C
3b	C	C	C	C
4	C	C	C	C
5	C	E	E	E

Table 15. Electrical transient requirements on V_{CC} pin (part 3)

Class	Contents
C	All functions of the device are performed as designed after exposure to disturbance.
E	One or more functions of the device is not performed as designed after exposure and cannot be returned to proper operation without replacing the device.

Figure 6. Waveforms

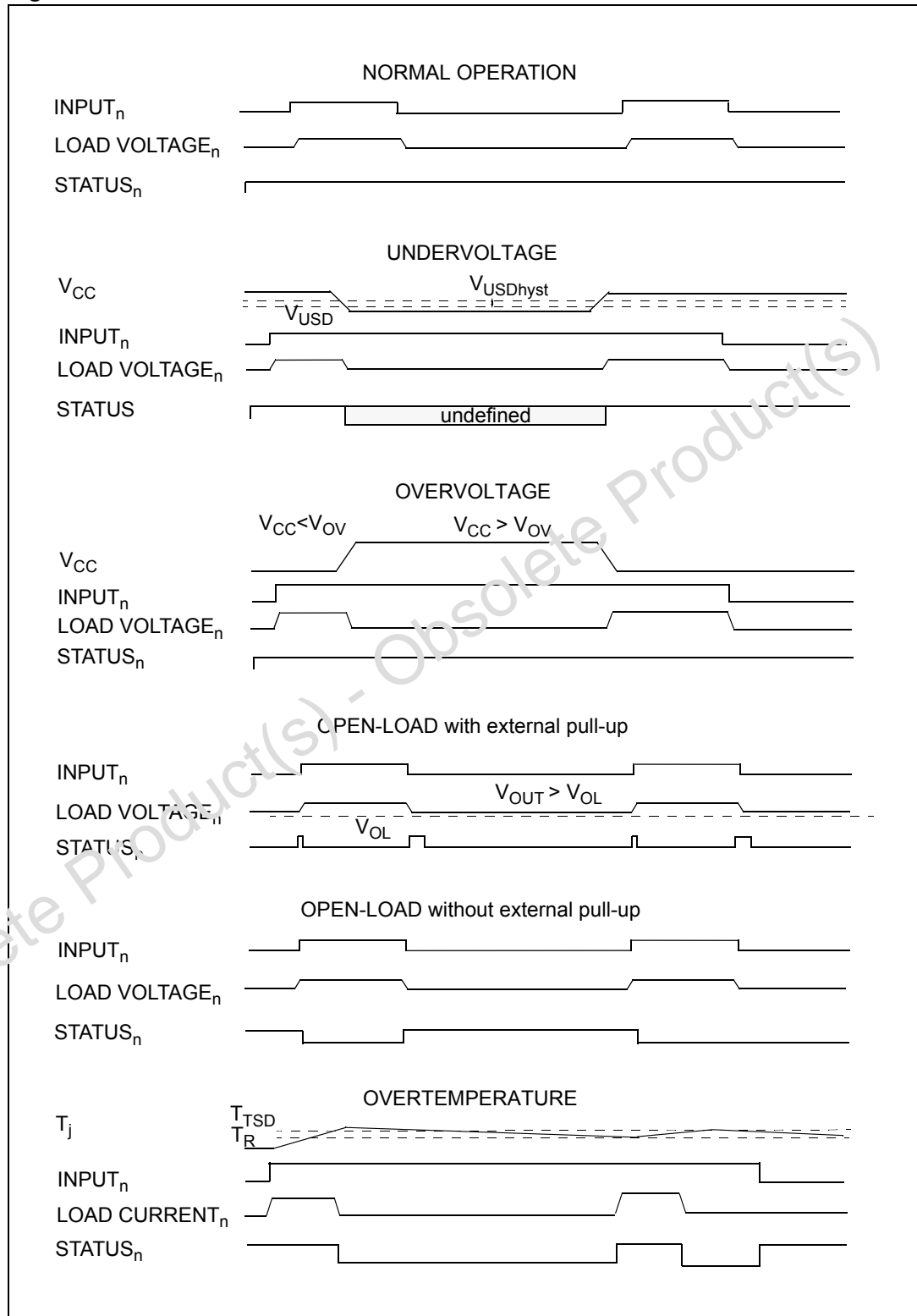

2.4 Electrical characteristics curves

Figure 7. Off-state output current

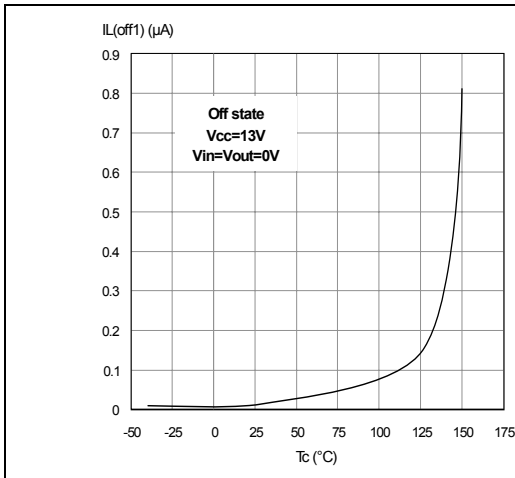

Figure 8. High level input current

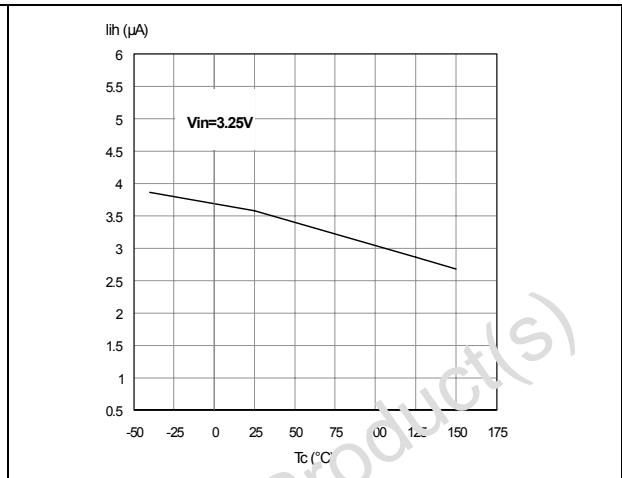

Figure 9. Input clamp voltage

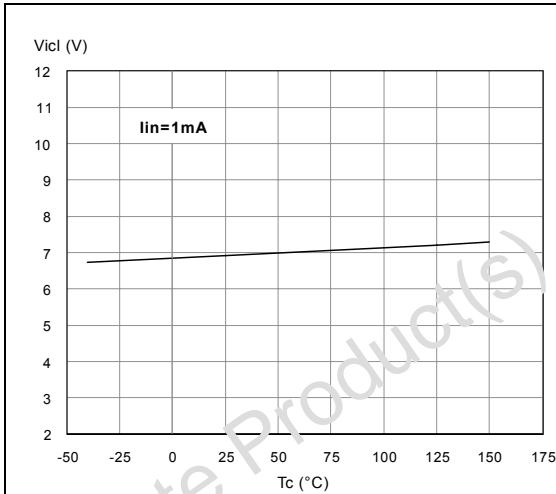

Figure 10. Status leakage current

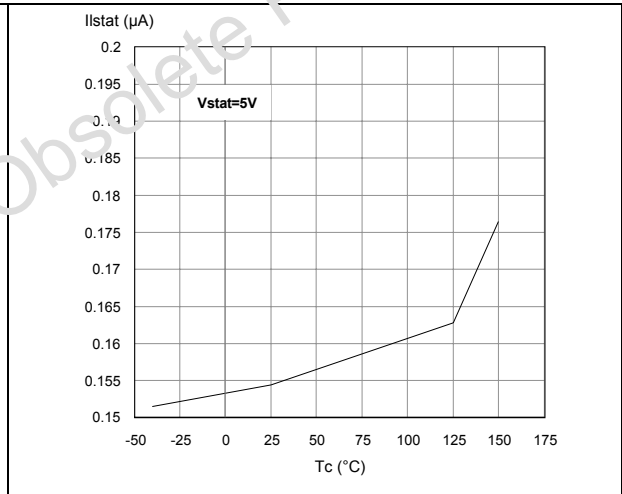

Figure 11. Status low output voltage

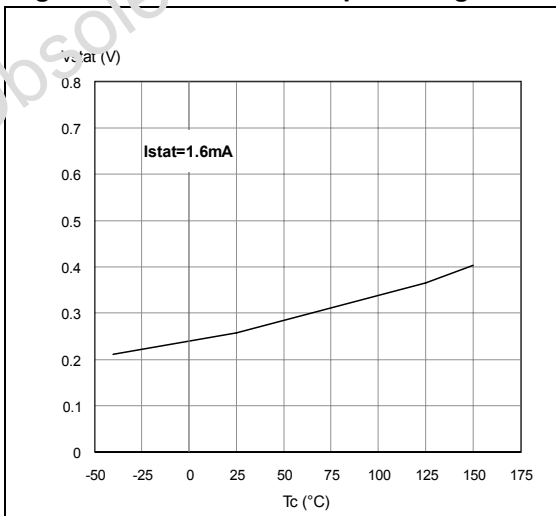

Figure 12. Status clamp voltage

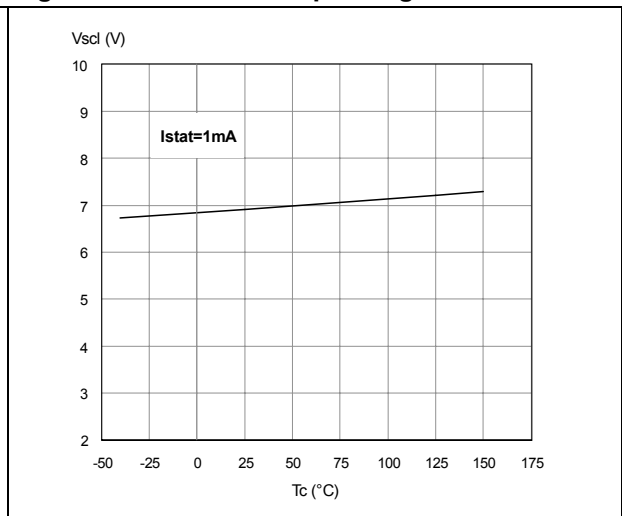

Figure 13. On-state resistance vs T_{case}

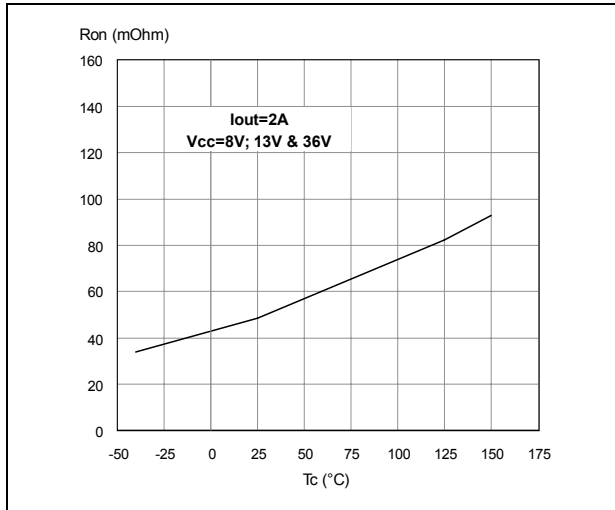

Figure 14. On-state resistance vs V_{CC}

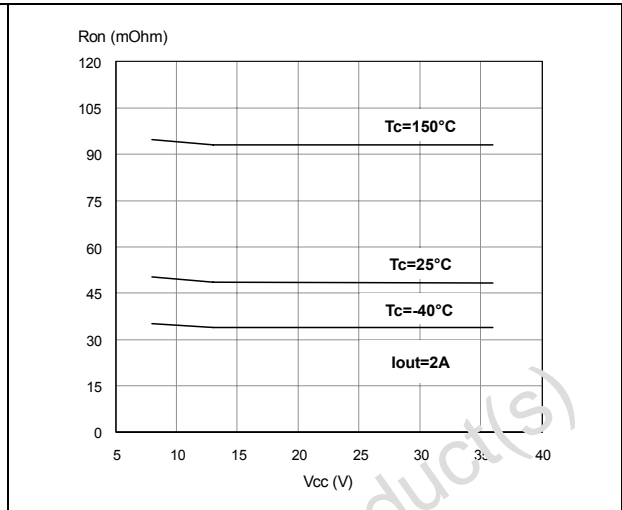

Figure 15. Open-load on-state detection threshold

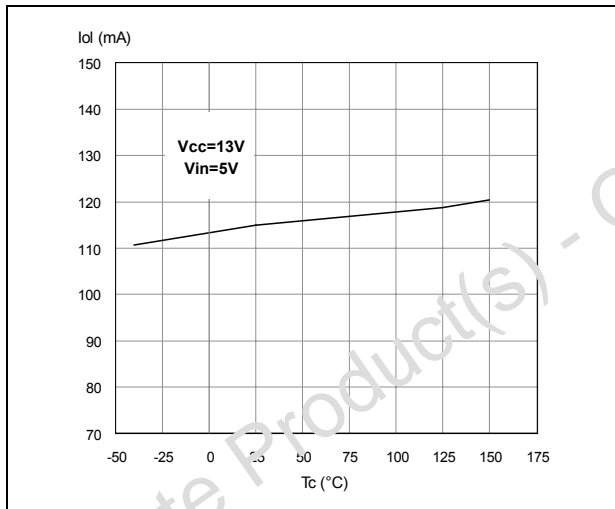

Figure 16. Open-load off-state detection threshold

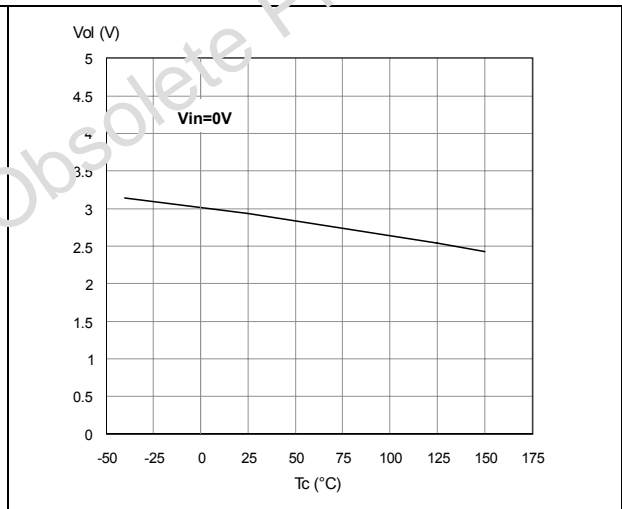

Figure 17. Input high level

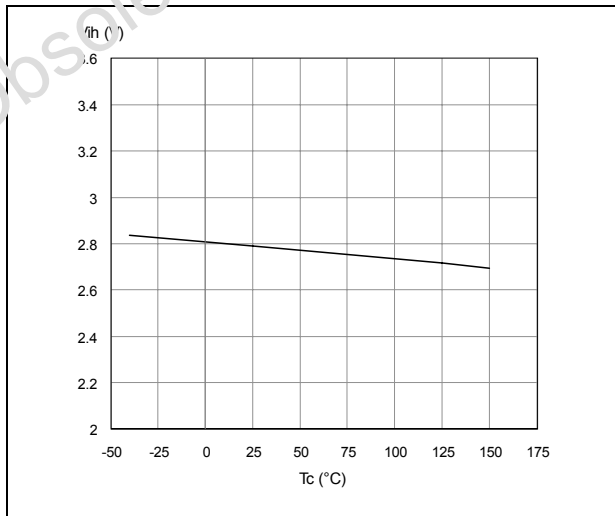

Figure 18. Input low level

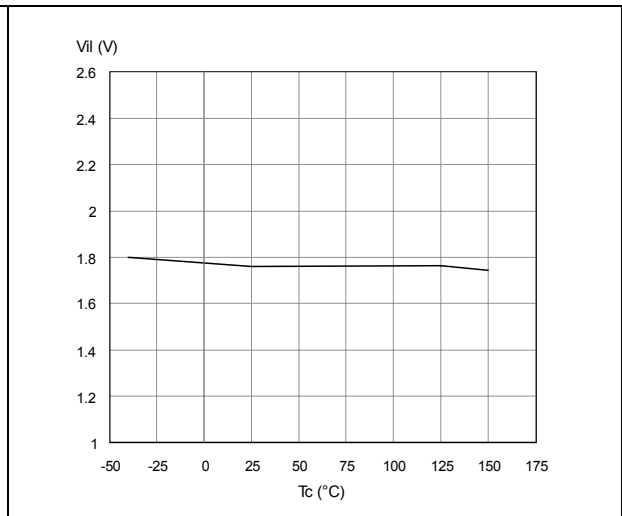

Figure 19. Input hysteresis voltage

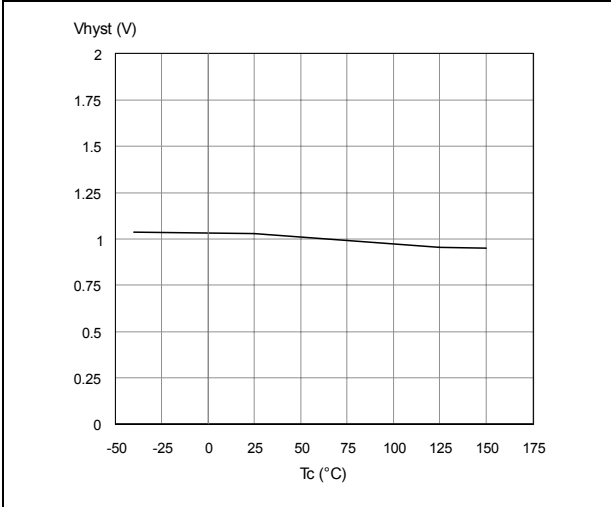

Figure 20. Overvoltage shutdown

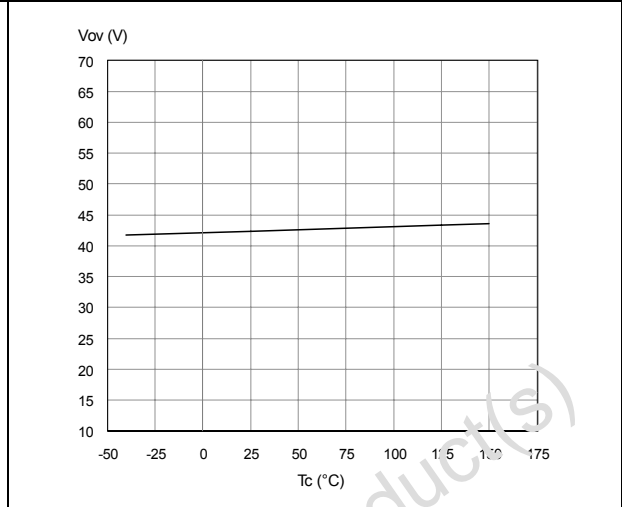

Figure 21. Turn-on voltage slope

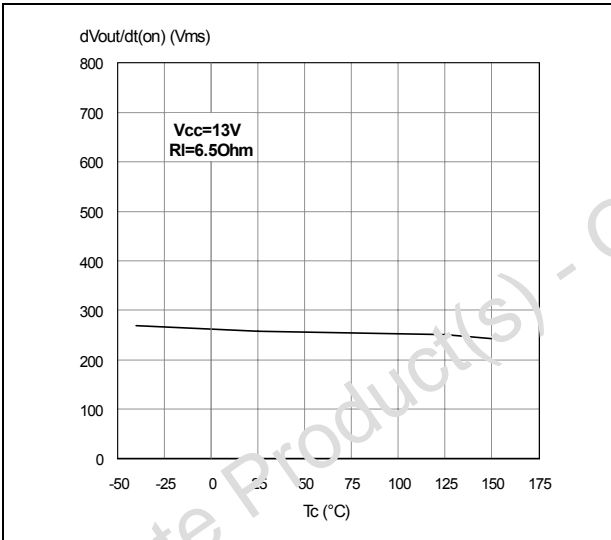

Figure 22. Turn-off voltage slope

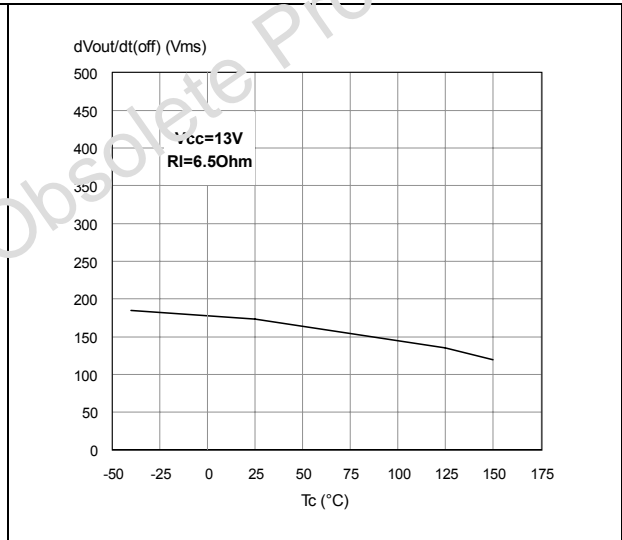

Figure 23. I_{LIM} vs T_{case}

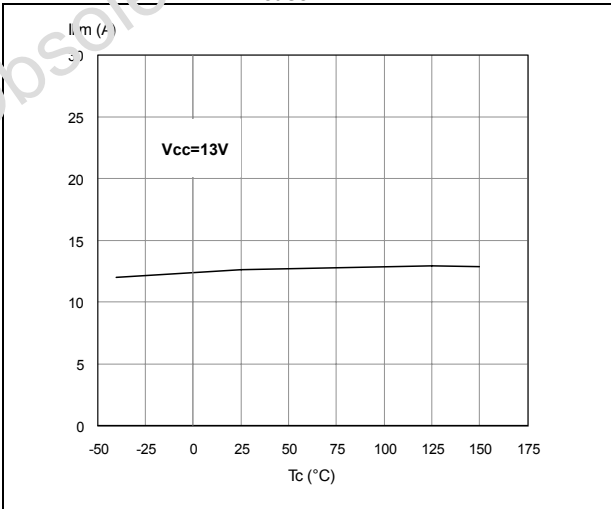
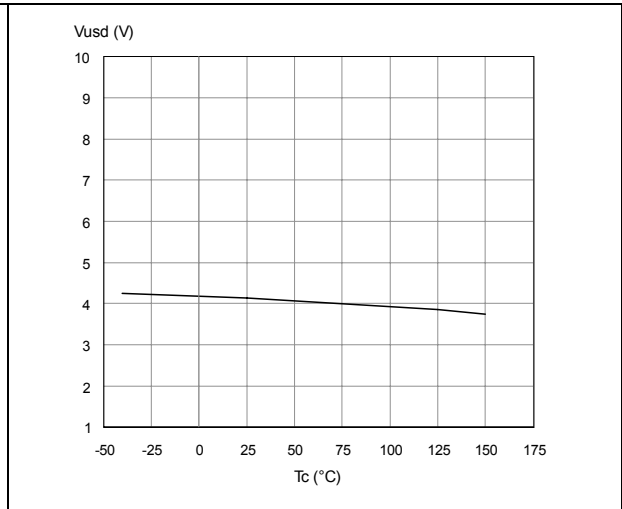
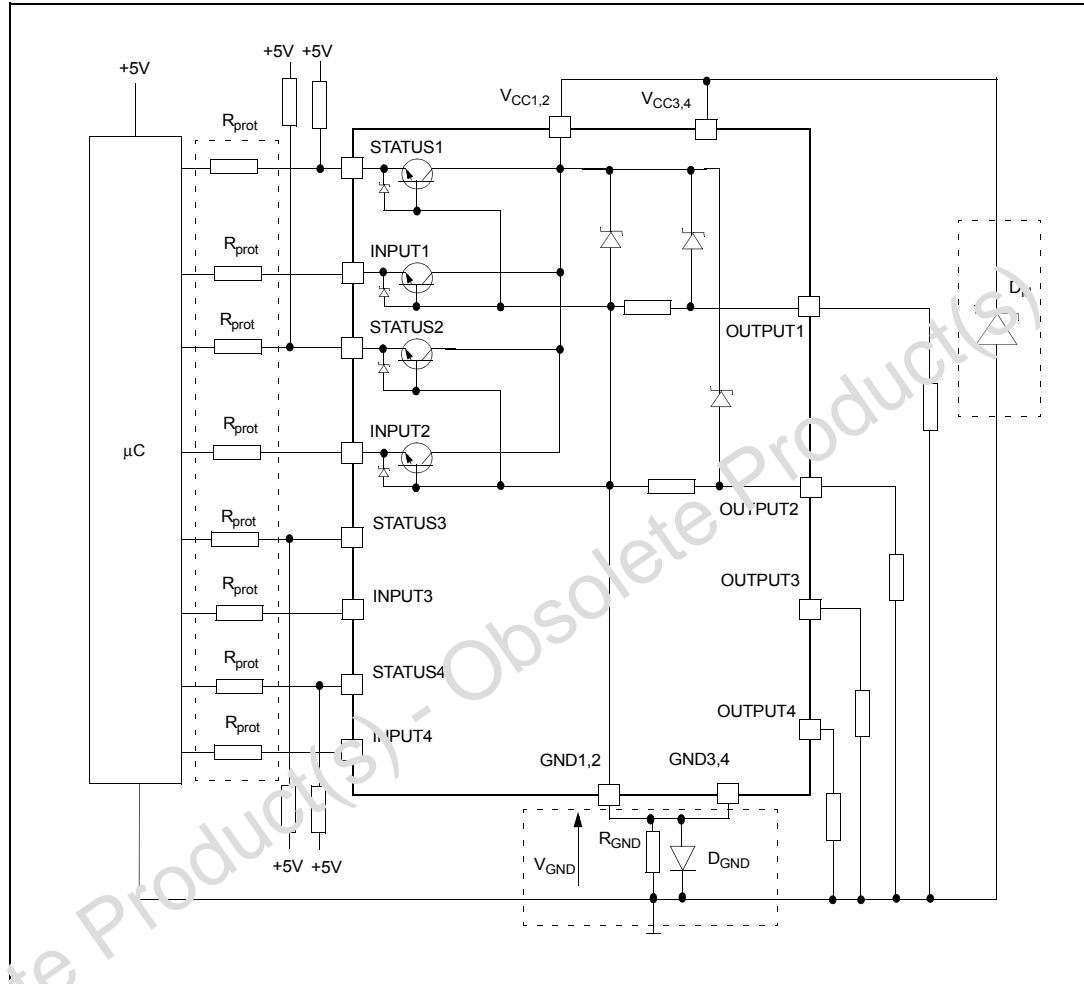

Figure 24. Undervoltage shutdown



3 Application information

Figure 25. Application schematic



Note: Channels 3 & 4 have the same internal circuit as channel 1 & 2.

3.1 GND protection network against reverse battery

This section provides two solutions for implementing a ground protection network against reverse battery.

3.1.1 Solution 1: a resistor in the ground line (R_{GND} only)

This can be used with any type of load.

The following show how to dimension the R_{GND} resistor:

1. $R_{GND} \leq 600mV / 2 (I_{S(on)max})$
2. $R_{GND} \geq (-V_{CC}) / (-I_{GND})$

where $-I_{GND}$ is the DC reverse ground pin current and can be found in the absolute maximum rating section of the device's datasheet.

Power dissipation in R_{GND} (when $V_{CC} < 0$ during reverse battery situations) is:

$$P_D = (-V_{CC})^2 / R_{GND}$$

This resistor can be shared amongst several different HSDs. Please note that the value of this resistor should be calculated with formula (1) where $I_{S(on)max}$ becomes the sum of the maximum on-state currents of the different devices.

Please note that, if the microprocessor ground is not shared by the device ground, then the R_{GND} produces a shift ($I_{S(on)max} * R_{GND}$) in the input thresholds and the status output values. This shift varies depending on how many devices are ON in the case of several high side drivers sharing the same R_{GND} .

If the calculated power dissipation requires the use of a large resistor, or several devices have to share the same resistor, then ST suggests using [Section 3.1.2](#) described below.

3.1.2 Solution 2: a diode (D_{GND}) in the ground line

A resistor ($R_{GND} = 1 \text{ k}\Omega$) should be inserted in parallel to D_{GND} if the device is driving an inductive load. This small signal diode can be safely shared amongst several different HSD. Also in this case, the presence of the ground network produces a shift ($\sim 600\text{mV}$) in the input threshold and the status output values if the microprocessor ground is not common with the device ground. This shift does not vary if more than one HSD shares the same diode/resistor network.

3.2 Load dump protection

D_{ld} is necessary (Voltage Transient Suppressor) if the load dump peak voltage exceeds the V_{CC} maximum DC rating. The same applies if the device is subject to transients on the V_{CC} line that are greater than those shown in [Table 13](#).

3.3 MCU I/O protection

if a ground protection network is used and negative transients are present on the V_{CC} line, the control pins are pulled negative. ST suggests to insert a resistor (R_{prot}) in line to prevent the microcontroller I/O pins from latching up.

The value of these resistors is a compromise between the leakage current of microcontroller and the current required by the HSD I/Os (Input levels compatibility) with the latch-up limit of microcontroller I/Os:

$$-V_{CCpeak} / I_{latchup} \leq R_{prot} \leq (V_{OH\mu C} - V_{IH} - V_{GND}) / I_{IHmax}$$

Example

For the following conditions:

$$V_{CCpeak} = -100 \text{ V and } I_{latchup} \geq 20 \text{ mA; } V_{OH\mu C} \geq 4.5 \text{ V}$$

$$5 \text{ k}\Omega \leq R_{prot} \leq 65 \text{ k}\Omega$$

Recommended values are:

$$R_{prot} = 10 \text{ k}\Omega$$

3.4 Open-load detection in off-state

Off-state open-load detection requires an external pull-up resistor (R_{PU}) connected between OUTPUT pin and a positive supply voltage (V_{PU}) like the +5 V line used to supply the microprocessor.

The external resistor has to be selected according to the following requirements:

1. No false open-load indication when load is connected: in this case we have to avoid V_{OUT} to be higher than V_{OLmin} ; this results in the following condition

$$V_{OUT} = (V_{PU} / (R_L + R_{PU}))R_L < V_{OLmin}.$$
2. No misdetection when load is disconnected: in this case the V_{OUT} has to be higher than V_{OLmax} ; this results in the following condition $R_{PU} < (V_{PU} - V_{OLmax}) / I_{L(off2)}$

Because $I_{S(OFF)}$ may significantly increase if V_{out} is pulled high (up to several mA), the pull-up resistor R_{PU} should be connected to a supply that is switched OFF when the module is in standby.

The values of V_{OLmin} , V_{OLmax} and $I_{L(off2)}$ are available in the [Chapter 2: Electrical specifications](#).

Figure 26. Open-load detection in off-state

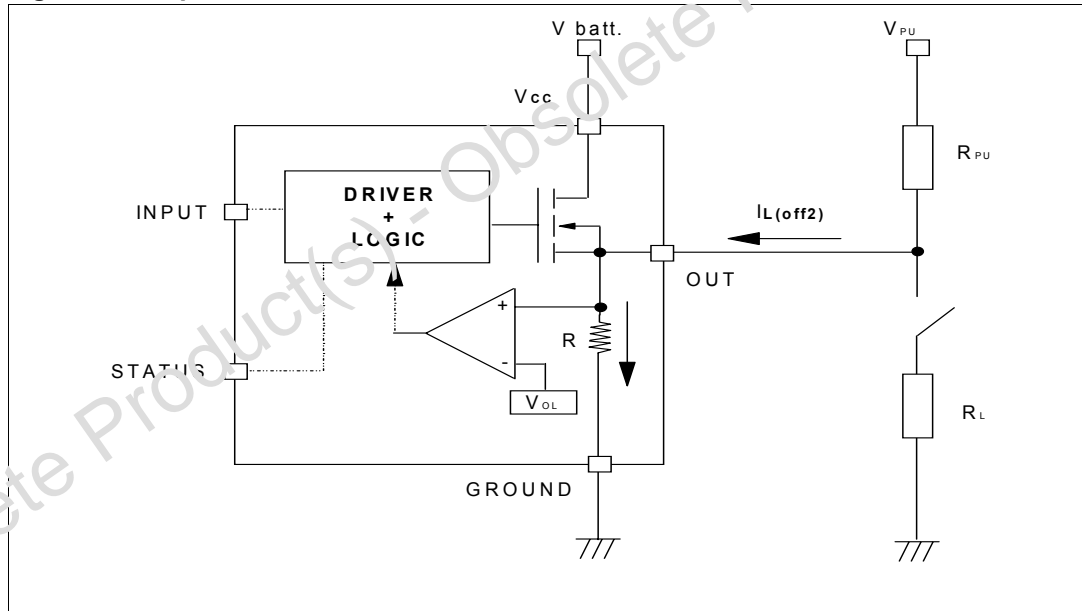

3.5 Maximum demagnetization energy

Figure 27. Maximum turn-off current versus load inductance

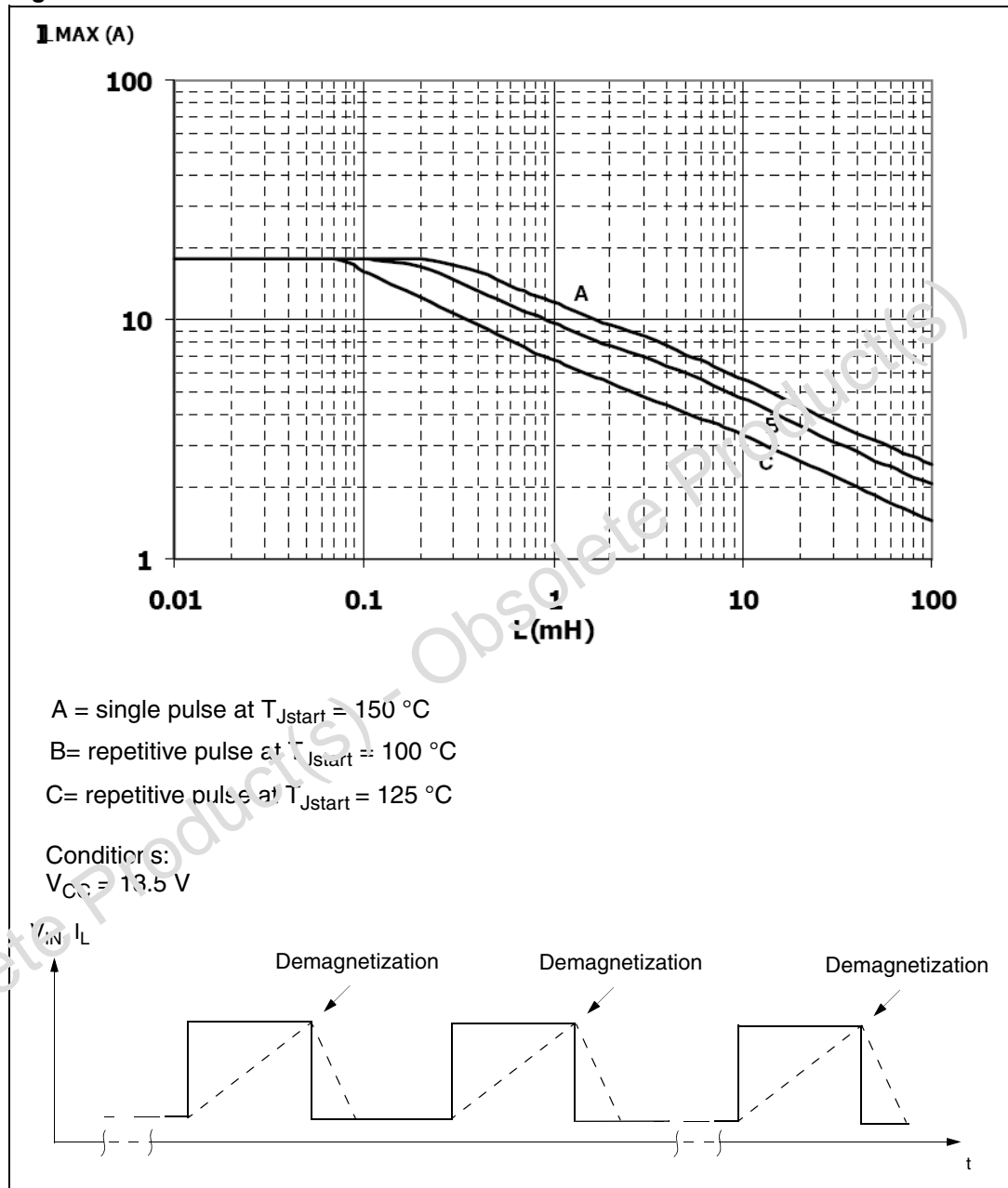

Note: Values are generated with $R_L = 0 \Omega$.
 In case of repetitive pulses, T_{Jstart} (at beginning of each demagnetization) of every pulse must not exceed the temperature specified above for curves B and C.

4 Package and PCB thermal data

4.1 SO-28 thermal data

Figure 28. SO-28 PC board

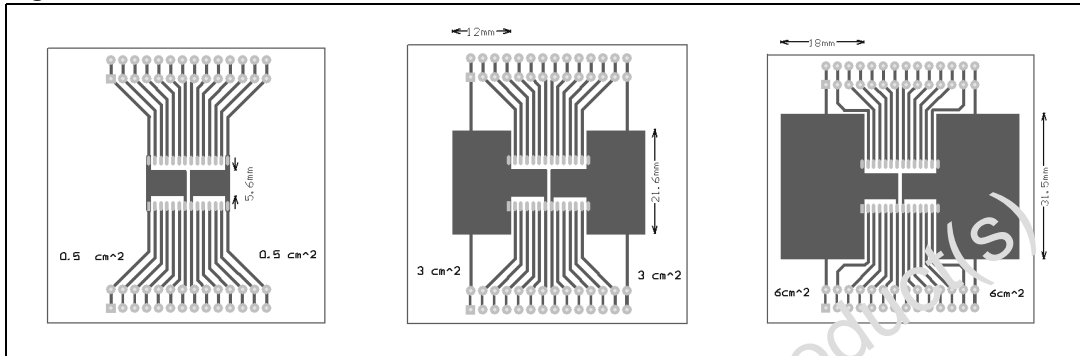

Note: Layout condition of R_{th} and Z_{th} measurements (PCB FR4 area = 58 mm x 58 mm, PCB thickness = 2 mm, Cu thickness = 35 μ m, Copper areas: 0.5 cm², 3 cm², 6 cm²).

Table 16. Thermal calculation according to the PCB heating area

Chip 1	Chip 2	T_{jchip1}	T_{jchip2}	Note
On	Off	$R_{thA} \times P_{dchip1} + T_{amb}$	$R_{thC} \times P_{dchip1} + T_{amb}$	
Off	On	$R_{thC} \times P_{dchip2} + T_{amb}$	$R_{thA} \times P_{dchip2} + T_{amb}$	
On	On	$R_{thB} \times (P_{dchip1} + P_{dchip2}) + T_{amb}$	$R_{thB} \times (P_{dchip1} + P_{dchip2}) + T_{amb}$	$P_{dchip1} = P_{dchip2}$
On	On	$(R_{thA} \times P_{dchip1}) + R_{thC} \times P_{dchip2} + T_{amb}$	$(R_{thA} \times P_{dchip2}) + R_{thC} \times P_{dchip1} + T_{amb}$	$P_{dchip1} \neq P_{dchip2}$

R_{thA} = thermal resistance junction to ambient with one chip ON

R_{thB} = thermal resistance junction to ambient with both chips ON and $P_{dchip1} = P_{dchip2}$

R_{thC} = mutual thermal resistance

Figure 29. $R_{thj-amb}$ vs PCB copper area in open box free air condition

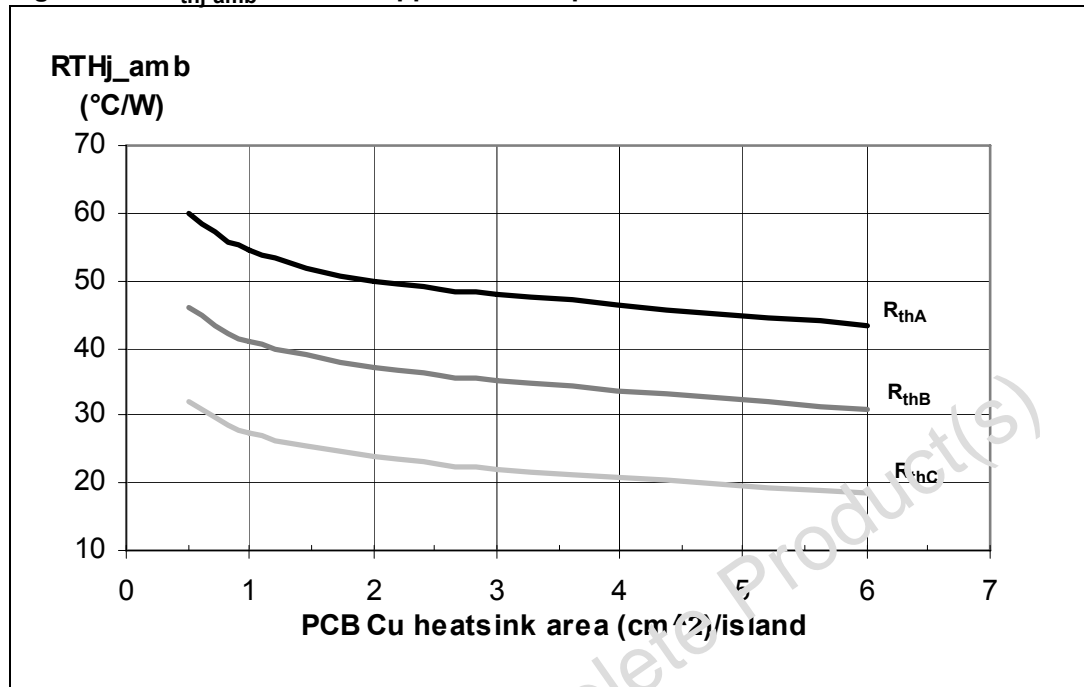
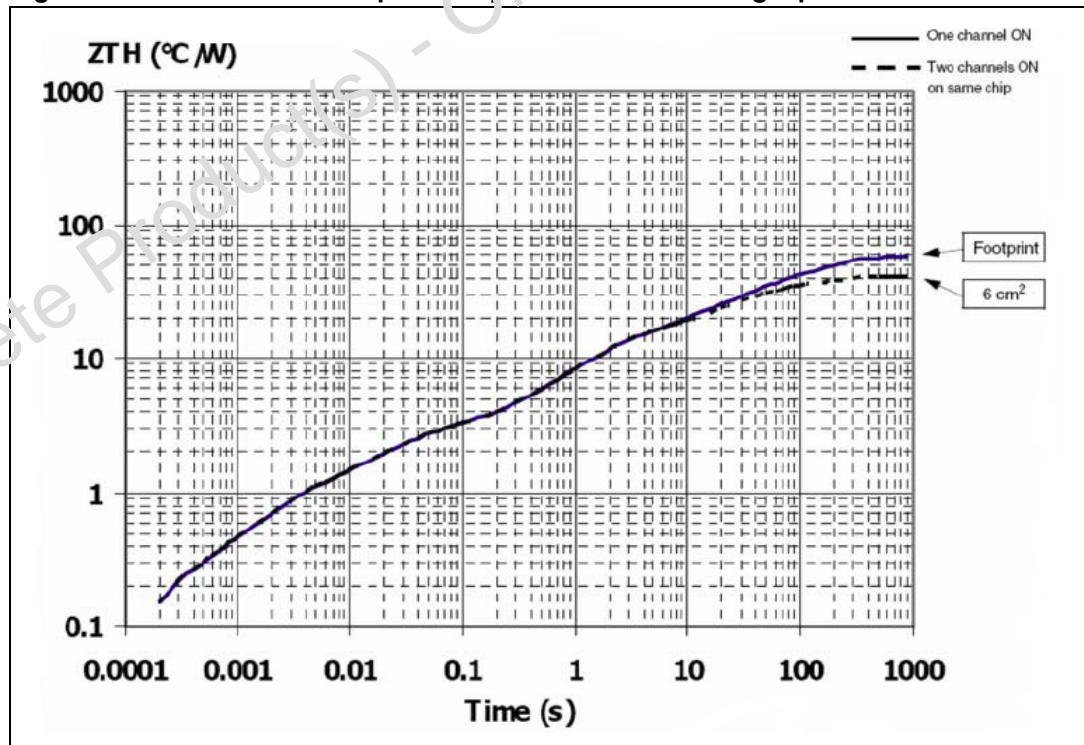

Figure 30. SP-28 thermal impedance function ambient single pulse



Equation 1: pulse calculation formula

$$Z_{TH\delta} = R_{TH} \cdot \delta + Z_{THtp}(1 - \delta)$$

where $\delta = t_p/T$

Figure 31. Thermal fitting model of a quad channel HSD in SO-28

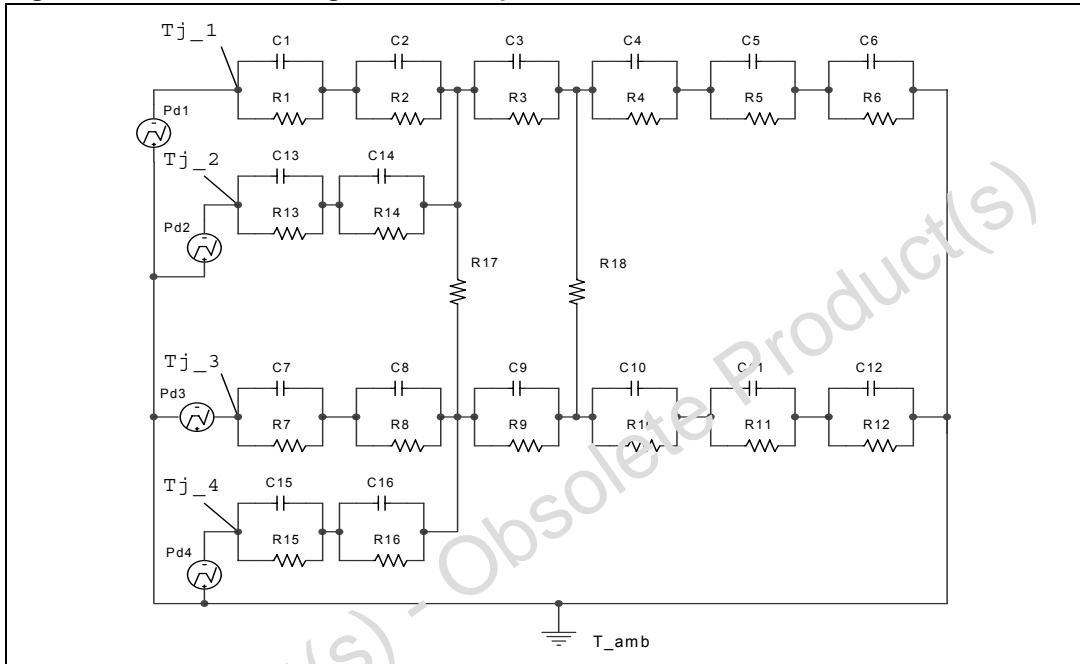

Table 17. Thermal parameters

Area / island (cm ²)	Footprint	6
R1 = R7 = R13 = R15 (°C/W)	0.15	
R2 = R8 = R14 = R16 (°C/W)	0.7	
R3 = R9 (°C/W)	1.8	
R4 = R10 (°C/W)	10	
R5 = R11 (°C/W)	15	
R6 = R12 (°C/W)	30	13
C1 = C7 = C13 = C15 (W.s/°C)	0.0005	
C2 = C8 = C14 = C16 (W.s/°C)	0.003	
C3 = C9 (W.s/°C)	0.015	
C4 = C10 (W.s/°C)	0.15	
C5 = C11 (W.s/°C)	1.5	
C6 = C12 (W.s/°C)	5	8
R17 = R18 (°C/W)	150	

5 Package and packing information

5.1 ECOPACK[®] packages

In order to meet environmental requirements, ST offers these devices in different grades of ECOPACK[®] packages, depending on their level of environmental compliance. ECOPACK[®] specifications, grade definitions and product status are available at: www.st.com. ECOPACK[®] is an ST trademark.

Figure 32. SO-28 package dimensions

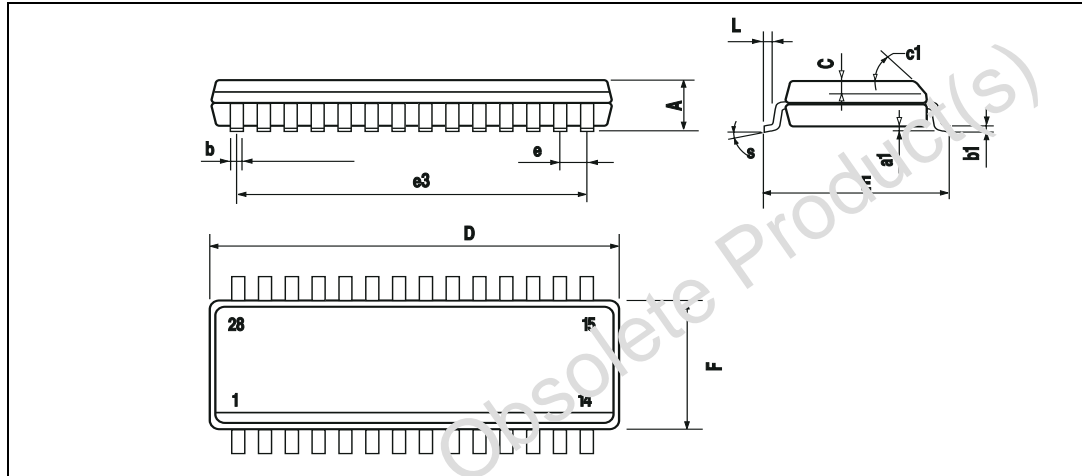

Table 18. SO-28 mechanical data

Symbol	Millimeters		
	Min.	Typ.	Max.
A			2.65
a1	0.10		0.30
b	0.35		0.49
b1	0.23		0.32
C		0.50	
c1	45° (typ.)		
D	17.7		18.1
E	10.00		10.65
e		1.27	
e3		16.51	
F	7.40		7.60
L	0.40		1.27
S	8° (max.)		

5.2 SO-28 packing information

Figure 33. SO-28 tube shipment (no suffix)

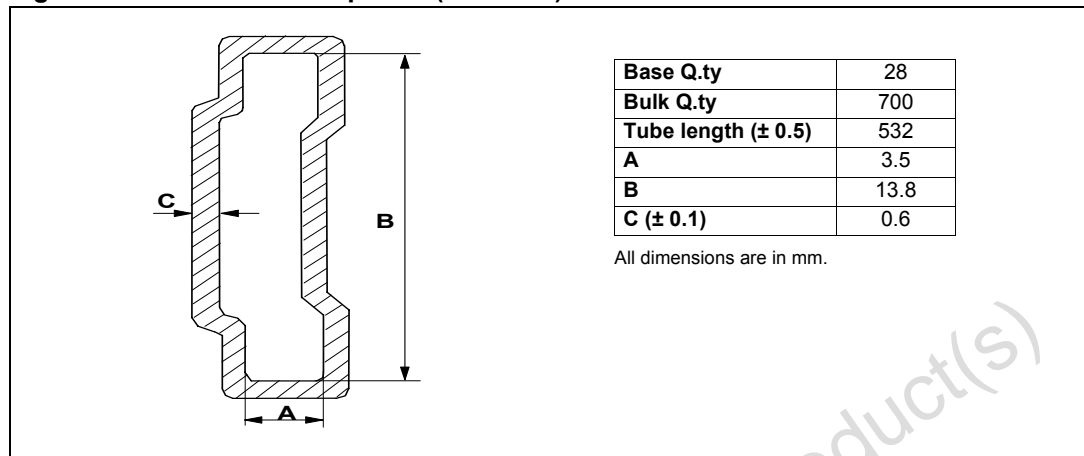
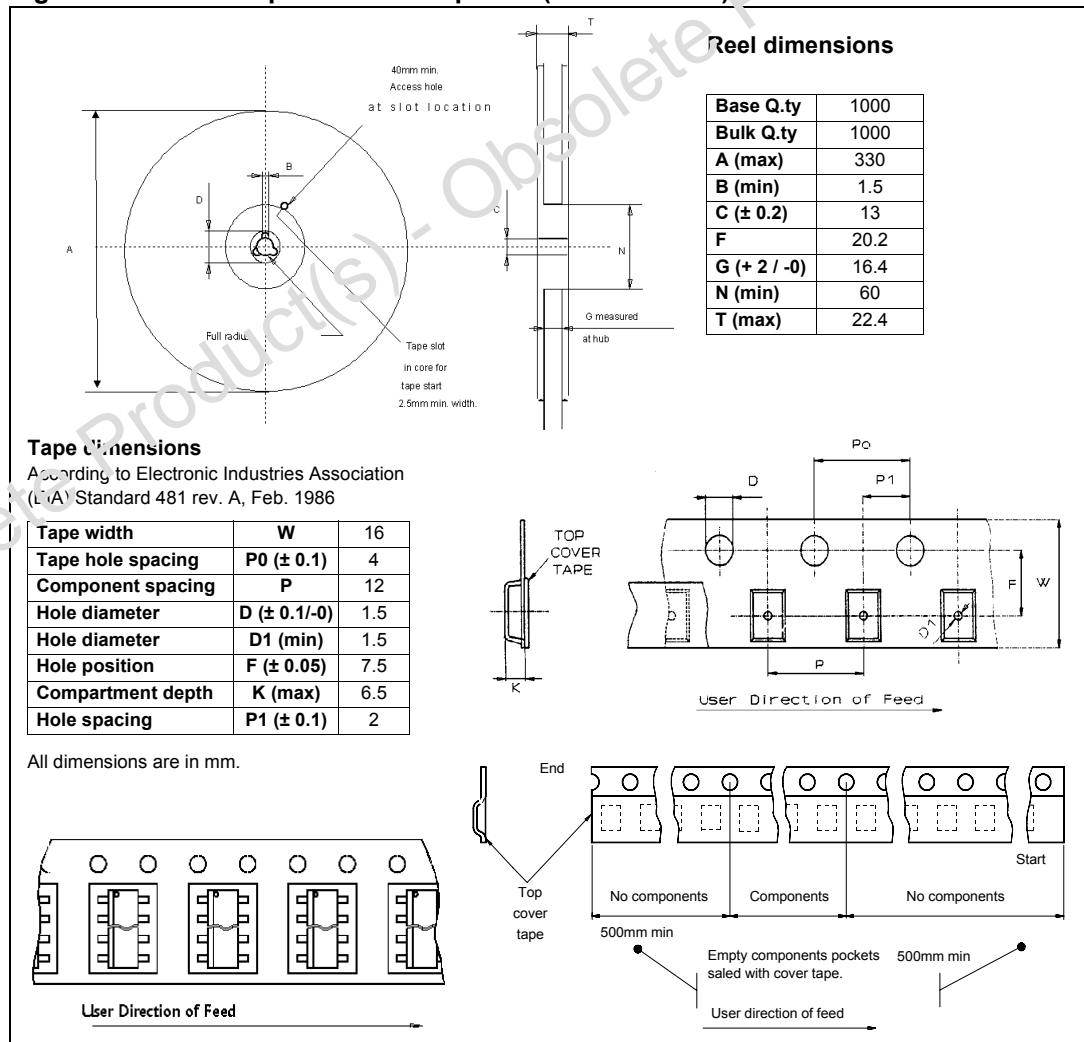

Figure 34. SO-28 tape and reel shipment (suffix "13TR")



6 Revision history

Table 19. Document revision history

Date	Revision	Changes
03-May-2010	1	Initial release.

Obsolete Product(s) - Obsolete Product(s)

Please Read Carefully:

Information in this document is provided solely in connection with ST products. STMicroelectronics NV and its subsidiaries ("ST") reserve the right to make changes, corrections, modifications or improvements, to this document, and the products and services described herein at any time, without notice.

All ST products are sold pursuant to ST's terms and conditions of sale.

Purchasers are solely responsible for the choice, selection and use of the ST products and services described herein, and ST assumes no liability whatsoever relating to the choice, selection or use of the ST products and services described herein.

No license, express or implied, by estoppel or otherwise, to any intellectual property rights is granted under this document. If any part of this document refers to any third party products or services it shall not be deemed a license grant by ST for the use of such third party products or services, or any intellectual property contained therein or considered as a warranty covering the use in any manner whatsoever of such third party products or services or any intellectual property contained therein.

UNLESS OTHERWISE SET FORTH IN ST'S TERMS AND CONDITIONS OF SALE ST DISCLAIMS ANY EXPRESS OR IMPLIED WARRANTY WITH RESPECT TO THE USE AND/OR SALE OF ST PRODUCTS INCLUDING WITHOUT LIMITATION IMPLIED WARRANTIES OF MERCHANTABILITY, FITNESS FOR A PARTICULAR PURPOSE (AND THEIR EQUIVALENTS UNDER THE LAWS OF ANY JURISDICTION), OR INFRINGEMENT OF ANY PATENT, COPYRIGHT OR OTHER INTELLECTUAL PROPERTY RIGHT.

UNLESS EXPRESSLY APPROVED IN WRITING BY AN AUTHORIZED ST REPRESENTATIVE, ST PRODUCTS ARE NOT RECOMMENDED, AUTHORIZED OR WARRANTED FOR USE IN MILITARY, AIR CRAFT, SPACE, LIFE SAVING, OR LIFE SUSTAINING APPLICATIONS, NOR IN PRODUCTS OR SYSTEMS WHERE FAILURE OR MALFUNCTION MAY RESULT IN PERSONAL INJURY, DEATH, OR SEVERE PROPERTY OR ENVIRONMENTAL DAMAGE. ST PRODUCTS WHICH ARE NOT SPECIFIED AS "AUTOMOTIVE GRADE" MAY ONLY BE USED IN AUTOMOTIVE APPLICATIONS AT USER'S OWN RISK.

Resale of ST products with provisions different from the statements and/or technical features set forth in this document shall immediately void any warranty granted by ST for the ST product or service described herein and shall not create or extend in any manner whatsoever, any liability of ST.

ST and the ST logo are trademarks or registered trademarks of ST in various countries.

Information in this document supersedes and replaces all information previously supplied.

The ST logo is a registered trademark of STMicroelectronics. All other names are the property of their respective owners.

© 2010 STMicroelectronics - All rights reserved

STMicroelectronics group of companies

Australia - Belgium - Brazil - Canada - China - Czech Republic - Finland - France - Germany - Hong Kong - India - Israel - Italy - Japan - Malaysia - Malta - Morocco - Philippines - Singapore - Spain - Sweden - Switzerland - United Kingdom - United States of America

www.st.com

Компания «Life Electronics» занимается поставками электронных компонентов импортного и отечественного производства от производителей и со складов крупных дистрибьюторов Европы, Америки и Азии.

С конца 2013 года компания активно расширяет линейку поставок компонентов по направлению коаксиальный кабель, кварцевые генераторы и конденсаторы (керамические, пленочные, электролитические), за счёт заключения дистрибьюторских договоров

Мы предлагаем:

- Конкуренспособные цены и скидки постоянным клиентам.
- Специальные условия для постоянных клиентов.
- Подбор аналогов.
- Поставку компонентов в любых объемах, удовлетворяющих вашим потребностям.
- Приемлемые сроки поставки, возможна ускоренная поставка.
- Доставку товара в любую точку России и стран СНГ.
- Комплексную поставку.
- Работу по проектам и поставку образцов.
- Формирование склада под заказчика.
- Сертификаты соответствия на поставляемую продукцию (по желанию клиента).
- Тестирование поставляемой продукции.
- Поставку компонентов, требующих военную и космическую приемку.
- Входной контроль качества.
- Наличие сертификата ISO.

В составе нашей компании организован Конструкторский отдел, призванный помогать разработчикам, и инженерам.

Конструкторский отдел помогает осуществить:

- Регистрацию проекта у производителя компонентов.
- Техническую поддержку проекта.
- Защиту от снятия компонента с производства.
- Оценку стоимости проекта по компонентам.
- Изготовление тестовой платы монтаж и пусконаладочные работы.



Тел: +7 (812) 336 43 04 (многоканальный)

Email: org@lifeelectronics.ru