

FEATURES

Ultracompact solution

- Small, 2 mm × 1.7 mm, 12-ball WLCSP package
- Smallest footprint, 1 mm height, 1 μH power inductor

LED current source for local LED grounding

- Simplified routing to and from LEDs
- Improved LED thermal dissipation

Synchronous 3 MHz PWM boost converter, no external diode

High efficiency: 90% peak

- Reduces high levels of input battery current during flash
- Limits battery current drain in torch mode

I²C programmable

- Currents up to 750 mA in flash mode per LED with ±7% accuracy for currents above 100 mA

Torch mode

- Programmable dc battery current limit
- Programmable flash timer up to 1600 ms
- Low battery mode to reduce LED current automatically

Device control

- I²C-compatible control registers
- External STROBE and torch input pins
- Transmitter mask (TxMASK) input

Safety features

- Thermal overload protection
- Inductor fault detection
- LED short-circuit/open-circuit protection

APPLICATIONS

- Camera-enabled cellular phones and smartphones
- Digital still cameras, camcorders, and PDAs

GENERAL DESCRIPTION

The ADP1660 is a very compact, highly efficient, dual white LED flash driver for high resolution camera phones that improves picture and video quality in low light environments. The device integrates a programmable 1.5 MHz or 3.0 MHz synchronous inductive boost converter, an I²C-compatible interface, and two 750 mA current sources. The high switching frequency enables the use of a tiny, 1 mm high, low cost, 1 μH power inductor, and the parallel current sources permit LED cathode grounding for thermally enhanced, low EMI, and compact layouts.

The LED driver maximizes efficiency over the entire battery voltage range to maximize the input-power-to-LED-power conversion and minimize battery current draw during flash events.

FUNCTIONAL BLOCK DIAGRAM

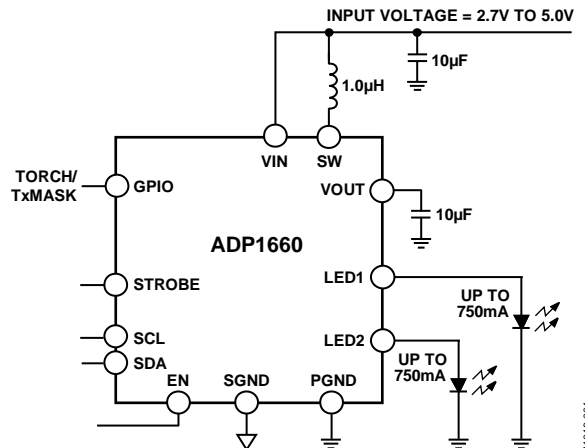

Figure 1.

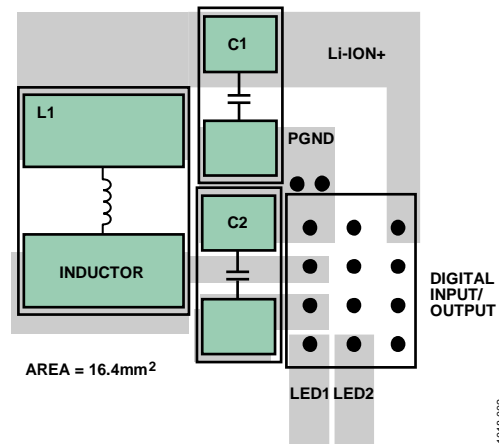

Figure 2. PCB Layout

A programmable dc battery current limit safely maximizes LED current for all LED forward voltage and battery voltage conditions.

A TxMASK input enables fast reduction of the flash LED currents and battery current during a power amplifier current burst. The I²C-compatible interface can be used to program timers and currents and to read back status bits for operation monitoring and safety control.

The ADP1660 comes in a compact, 12-ball, 0.5 mm pitch WLCSP package and operates within specification over the full -40°C to +125°C junction temperature range.

Rev. 0

[Document Feedback](#)

Information furnished by Analog Devices is believed to be accurate and reliable. However, no responsibility is assumed by Analog Devices for its use, nor for any infringements of patents or other rights of third parties that may result from its use. Specifications subject to change without notice. No license is granted by implication or otherwise under any patent or patent rights of Analog Devices. Trademarks and registered trademarks are the property of their respective owners.

One Technology Way, P.O. Box 9106, Norwood, MA 02062-9106, U.S.A.
Tel: 781.329.4700 ©2012 Analog Devices, Inc. All rights reserved.
[Technical Support](#) www.analog.com

TABLE OF CONTENTS

Features	1	Fixed 5 V Output Mode.....	13
Applications.....	1	Frequency Foldback.....	13
Functional Block Diagram	1	Low Battery LED Current Foldback	13
General Description	1	Battery Input DC Current Limit	14
Revision History	2	Fixed 5 V Output Mode with Torch	15
Specifications.....	3	Safety Features.....	16
Recommended Specifications: Input and Output Capacitance and Inductance	4	Short-Circuit Fault	16
I ² C-Compatible Interface Timing Specifications	5	Overvoltage Fault	16
Absolute Maximum Ratings.....	6	Dynamic Overvoltage Protection Mode	16
Thermal Data	6	Timeout Fault.....	16
Thermal Resistance	6	Overtemperature Fault	16
ESD Caution.....	6	Current Limit.....	16
Pin Configuration and Function Descriptions.....	7	Input Undervoltage	16
Typical Performance Characteristics	8	Soft Start	16
Theory of Operation	10	Reset Using the Enable (EN) Pin	16
White LED Driver	10	Clearing Faults.....	16
Modes of Operation	10	I ² C Interface	17
Assist Light Mode.....	11	Register Map	18
Flash Mode	11	Register Details.....	18
Assist to Flash Mode	12	Applications Information	24
Torch Mode	12	External Component Selection	24
Torch to Flash Mode	12	PCB Layout.....	25
TxMASK Operation.....	12	Outline Dimensions	26
Independent Trigger Modes.....	13	Ordering Guide	26

REVISION HISTORY

10/12—Revision 0: Initial Version

SPECIFICATIONS

$V_{IN}^1 = 3.6\text{ V}$, $T_J = -40^\circ\text{C}$ to $+125^\circ\text{C}$ for minimum/maximum specifications, and $T_A = 25^\circ\text{C}$ for typical specifications, unless otherwise noted.

Table 1.

Parameter ²	Test Conditions/Comments	Min	Typ	Max	Unit
SUPPLY					
Input Voltage Range		2.7		5.0	V
Undervoltage Lockout Threshold	V_{IN} falling	2.3	2.4	2.5	V
Undervoltage Lockout Hysteresis		50	100	150	mV
Shutdown Current, $EN = 0\text{ V}$	$T_J = -40^\circ\text{C}$ to $+85^\circ\text{C}$, current into V_{IN} pin, $V_{IN} = 2.7\text{ V}$ to 4.5 V		0.2	1	μA
Standby Current, $EN = 1.8\text{ V}$	$T_J = -40^\circ\text{C}$ to $+85^\circ\text{C}$, current into V_{IN} pin, $V_{IN} = 2.7\text{ V}$ to 4.5 V		3	10	μA
Operating Quiescent Current	Torch mode, $I_{LED} = 100\text{ mA}$		5.3		mA
SW Switch Leakage Current	$T_J = -40^\circ\text{C}$ to $+85^\circ\text{C}$, $V_{SW}^3 = 5\text{ V}$ $T_J = 25^\circ\text{C}$, $V_{SW}^3 = 5\text{ V}$			2 0.5	μA μA
LED DRIVER					
LED Current					
Assist Light, Torch Mode Current	Assist light value setting = 0 (0 0000 binary)		0		mA
	Assist light value setting = 16 (1 0000 binary)		200		mA
Flash Mode Current	Flash value setting = 0 (00 0000 binary)		0		mA
	Flash value setting = 60 (11 1100 binary)		750		mA
LED Current Error per Channel	$I_{LED} = 200\text{ mA}$ to 750 mA	-5	± 1	+5	%
	$I_{LED} = 100\text{ mA}$ to 187.5 mA	-7	± 1	+7	%
	$I_{LED} = 50\text{ mA}$ to 87.5 mA		± 3		%
	$I_{LED} = 25\text{ mA}$ to 37.5 mA		± 6		%
	$I_{LED} = 12.5\text{ mA}$		± 10		%
LED Channel Mismatch	$I_{LED} = 275\text{ mA}$ to 750 mA		0.5	3	%
	$I_{LED} = 137.5\text{ mA}$ to 262.5 mA		1	4	%
	$I_{LED} = 25\text{ mA}$ to 125 mA		2		%
	$I_{LED} = 12.5\text{ mA}$		4		%
LED Current Source Headroom	Flash mode, $I_{LED} = 750\text{ mA}$		290		mV
	Torch mode, $I_{LED} = 200\text{ mA}$		190		mV
LED1/LED2 Ramp-Up Time				0.6	ms
LED1/LED2 Ramp-Down Time				0.1	ms
SWITCHING REGULATOR					
Switching Frequency	Switching frequency = 3 MHz	2.8	3.0	3.2	MHz
	Switching frequency = 1.5 MHz	1.4	1.5	1.6	MHz
Minimum Duty Cycle	Switching frequency = 3 MHz		14		%
	Switching frequency = 1.5 MHz		7		%
N-FET Resistance			60		$\text{m}\Omega$
P-FET Resistance			50		$\text{m}\Omega$
Voltage Output Mode					
V_{OUT} Voltage		4.575	5	5.425	V
Output Current				500	mA
Line Regulation	I_{LOAD} at V_{OUT} pin = 300 mA		0.3		%/V
Load Regulation			-0.7		%/A
Pass-Through Mode Transition					
Flash Mode					
V_{IN} to LED1/LED2, Entry	$I_{LED1} = I_{LED2} = 750\text{ mA}$		580		mV
V_{IN} to LED1/LED2, Exit	$I_{LED1} = I_{LED2} = 750\text{ mA}$		435		mV
Torch Mode					
V_{IN} to LED1/LED2, Entry	$I_{LED} = 200\text{ mA}$		380		mV
V_{IN} to LED1/LED2, Exit	$I_{LED} = 200\text{ mA}$		285		mV

Parameter ²	Test Conditions/Comments	Min	Typ	Max	Unit
DIGITAL INPUTS/GPIO PIN					
Input Logic Low Voltage				0.54	V
Input Logic High Voltage		1.26			V
GPIO, STROBE Pull-Down Resistance			390		kΩ
Torch Glitch Filtering Delay ⁴	From GPIO (torch) rising edge to device start	7.4	8.0	8.6	ms
SAFETY FEATURES					
Maximum Timeout for Flash			1600		ms
Timer Accuracy		-7.0		+7.0	%
DC Current Limit ⁵	DC current value setting = 0 (000 binary)	0.9	1.0	1.1	A
	DC current value setting = 1 (001 binary)	1.1	1.25	1.4	A
	DC current value setting = 2 (010 binary)	1.35	1.5	1.65	A
	DC current value setting = 3 (011 binary)	1.55	1.75	1.95	A
	DC current value setting = 4 (100 binary)	1.8	2.0	2.2	A
	DC current value setting = 5 (101 binary)	2.0	2.25	2.5	A
	DC current value setting = 6 (110 binary)	2.25	2.5	2.75	A
	DC current value setting = 7 (111 binary)	2.45	2.75	3.1	A
Low Battery Mode Transition Voltage Error				3.2	%
Hysteresis			50		mV
Coil Peak Current Limit ⁶	Peak current value setting = 0 (00 binary)	2.02	2.25	2.5	A
	Peak current value setting = 1 (01 binary)	2.47	2.75	3.0	A
	Peak current value setting = 2 (10 binary)	2.9	3.25	3.5	A
	Peak current value setting = 3 (11 binary)	3.15	3.5	3.85	A
Overvoltage Detection Threshold		5.15	5.5	5.9	V
LED1/LED2 Short-Circuit Detection Comparator Reference Voltage			1.0	1.3	V
Thermal Shutdown Threshold					
T _J Rising			150		°C
T _J Falling			140		°C

¹ V_{IN} is the input voltage to the circuit.

² All limits at temperature extremes are guaranteed via correlation using standard statistical quality control (SQC).

³ V_{SW} is the voltage on the SW switch pin.

⁴ Guaranteed by design. Torch glitch filtering depends directly on internal oscillator tolerances.

⁵ All dc current limit values are guaranteed by design except for the 1.25 A setting, which is tested in production.

⁶ All coil peak current limit values are guaranteed by design except for the 2.25 A setting, which is tested in production.

RECOMMENDED SPECIFICATIONS: INPUT AND OUTPUT CAPACITANCE AND INDUCTANCE

Table 2.

Parameter	Symbol	Test Conditions/Comments	Min	Typ	Max	Unit
CAPACITANCE	C _{MIN}	T _A = -40°C to +125°C				
Input			4.0	10		μF
Output			3.0	10	20	μF
MINIMUM AND MAXIMUM INDUCTANCE	L	T _A = -40°C to +125°C	0.6	1.0	1.5	μH

I²C-COMPATIBLE INTERFACE TIMING SPECIFICATIONS

Table 3.

Parameter ¹	Min	Max	Unit	Description
f _{SCL}		1000	kHz	SCL clock frequency
t _{HIGH}	0.26		μs	SCL high time
t _{LOW}	0.5		μs	SCL low time
t _{SU, DAT}	50		ns	Data setup time
t _{HD, DAT}	0	0.9	μs	Data hold time
t _{SU, STA}	0.26		μs	Setup time for repeated start
t _{HD, STA}	0.26		μs	Hold time for start/repeated start
t _{BUF}	0.5		μs	Bus free time between a stop and a start condition
t _{SU, STO}	0.26		μs	Setup time for stop condition
t _R	20 + 0.1 C _B ²	120	ns	Rise time of SCL and SDA
t _F	20 + 0.1 C _B ²	120	ns	Fall time of SCL and SDA
t _{SP}	0	50	ns	Pulse width of suppressed spike
C _B ²		400	pF	Capacitive load for each bus line

¹ Guaranteed by design.

² C_B is the total capacitance of one bus line in picofarads.

Timing Diagram

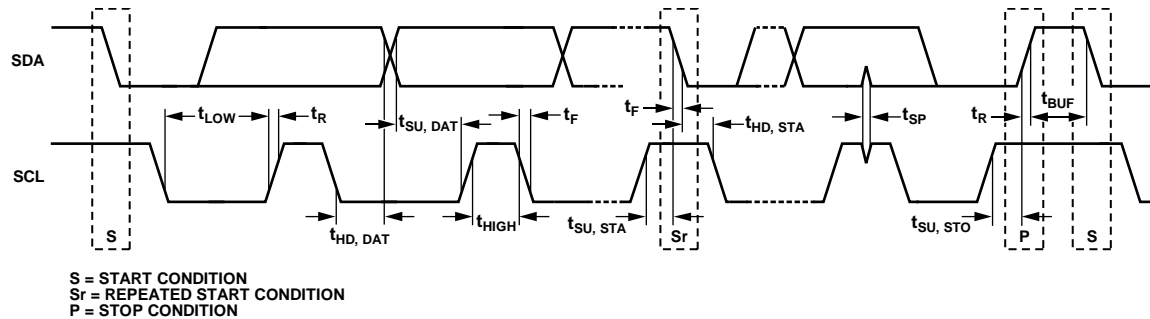

Figure 3. I²C-Compatible Interface Timing Diagram

11018-003

ABSOLUTE MAXIMUM RATINGS

Table 4.

Parameter	Rating
VIN, SDA, SCL, EN, GPIO, STROBE, LED1, LED2, SW, VOUT to PGND	−0.3 V to +6 V
PGND to SGND	−0.3 V to +0.3 V
Ambient Temperature Range (T _A)	−40°C to +85°C
Junction Temperature Range (T _J)	−40°C to +125°C
Storage Temperature	JEDEC J-STD-020
ESD	
Human Body Model	±1000 V
Charged Device Model	±500 V
Machine Model	±150 V

Stresses above those listed under Absolute Maximum Ratings may cause permanent damage to the device. This is a stress rating only; functional operation of the device at these or any other conditions above those indicated in the operational section of this specification is not implied. Exposure to absolute maximum rating conditions for extended periods may affect device reliability.

THERMAL DATA

The ADP1660 may be damaged if the junction temperature (T_J) limits are exceeded. Monitoring ambient temperature (T_A) does not guarantee that T_J is within the specified temperature limits. In applications with high power dissipation and poor PCB thermal resistance, the maximum T_A may need to be derated. In applications with moderate power dissipation and low PCB thermal resistance, the maximum T_A can exceed the maximum limit as long as T_J is within the specification limits.

The junction temperature (T_J) of the device is dependent on the ambient temperature (T_A), the power dissipation (P_D) of the device, and the junction-to-ambient thermal resistance (θ_{JA}) of the package. Maximum T_J is calculated from T_A and P_D using the following formula:

$$T_J = T_A + (P_D \times \theta_{JA})$$

THERMAL RESISTANCE

The junction-to-ambient thermal resistance (θ_{JA}) of the package is based on modeling and calculation using a 4-layer board. θ_{JA} is highly dependent on the application and board layout. In applications where high maximum power dissipation exists, close attention to thermal board design is required.

The value of θ_{JA} may vary, depending on PCB material, layout, and environmental conditions. The specified value of θ_{JA} is based on a 4-layer, 4 inch × 3 inch, 2½ oz copper board, per JEDEC standards. For more information, see the [AN-617 Application Note, Wafer Level Chip Scale Package](#).

In Table 5, θ_{JA} is specified for a device mounted on a JEDEC 2S2P PCB.

Table 5. Thermal Resistance

Package Type	θ _{JA}	Unit
12-Ball WLCSP	75	°C/W

ESD CAUTION



ESD (electrostatic discharge) sensitive device. Charged devices and circuit boards can discharge without detection. Although this product features patented or proprietary protection circuitry, damage may occur on devices subjected to high energy ESD. Therefore, proper ESD precautions should be taken to avoid performance degradation or loss of functionality.

PIN CONFIGURATION AND FUNCTION DESCRIPTIONS

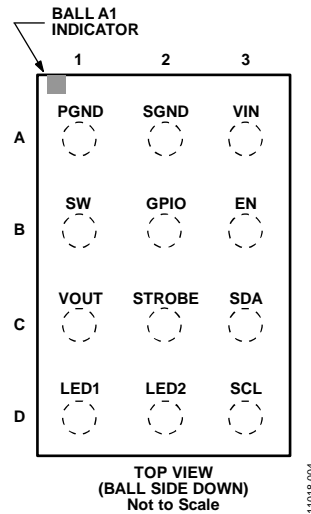

Figure 4. Pin Configuration

Table 6. Pin Function Descriptions

Pin No.	Mnemonic	Description
A1	PGND	Power Ground.
A2	SGND	Signal Ground.
A3	VIN	Input Voltage for the Device. Connect an input bypass capacitor very close to this pin.
B1	SW	Boost Switch. Connect the power inductor between SW and the input capacitor.
B2	GPIO	This pin enables the part to function in torch mode or functions as a TxMASK input, depending on the value set using Bits[5:4] in Register 0x02 (see Table 14). When this pin is configured as a TxMASK input, the flash current is reduced to the TxMASK current programmed in Register 0x07 (for LED1) and Register 0x0A (for LED2).
B3	EN	Enable. Set EN low to bring the quiescent current (I_Q) to $<1 \mu\text{A}$. Registers are set to their default values when EN is brought from low to high.
C1	VOUT	Boost Output. Connect an output bypass capacitor very close to this pin. This pin is the output for the 5 V external voltage mode.
C2	STROBE	Strobe Signal Input. This pin synchronizes the flash pulse to the image capture. In most cases, this signal comes directly from the image sensor.
C3	SDA	I ² C Data Signal.
D1	LED1	Current Source for LED1. Connect this pin to the anode of flash LED1.
D2	LED2	Current Source for LED2. Connect this pin to the anode of flash LED2.
D3	SCL	I ² C Clock Signal.

TYPICAL PERFORMANCE CHARACTERISTICS

I_{LED} = LED current, V_{LED} = LED output voltage, I_{BAT} = battery current.

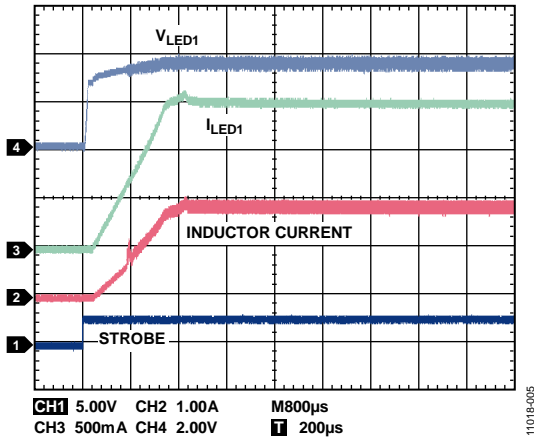

Figure 5. Startup, Flash Mode, $V_{IN} = 3.6V$, $I_{LED1} = I_{LED2} = 750mA$

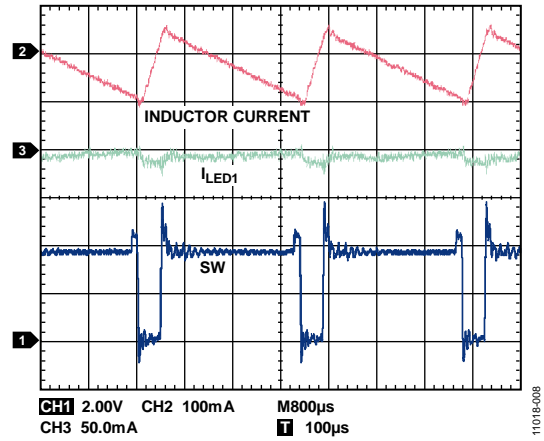

Figure 8. Switching Waveforms, Flash Mode, $I_{LED1} = I_{LED2} = 750mA$

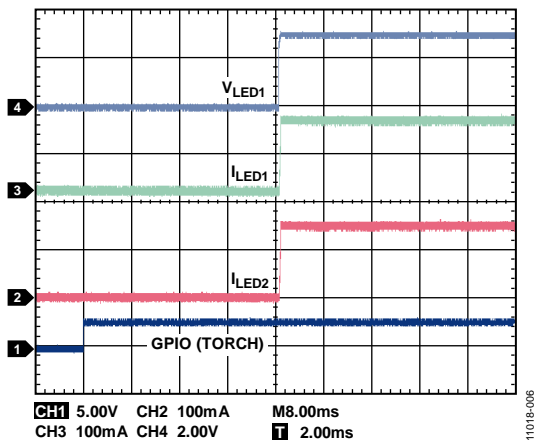

Figure 6. Startup, Torch Mode, $V_{IN} = 3.6V$, $I_{LED1} = I_{LED2} = 150mA$

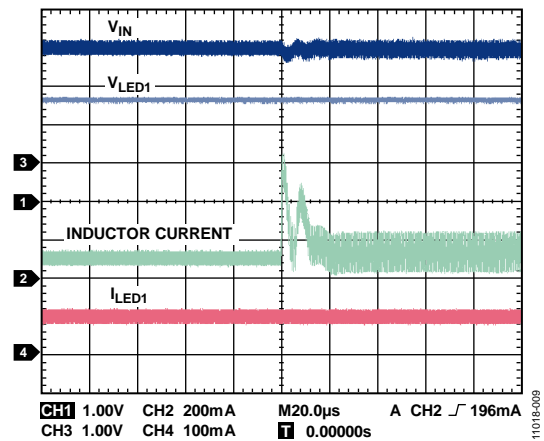

Figure 9. Pass-Through to Boost Mode Transition, Single LED, $I_{LED1} = 50mA$

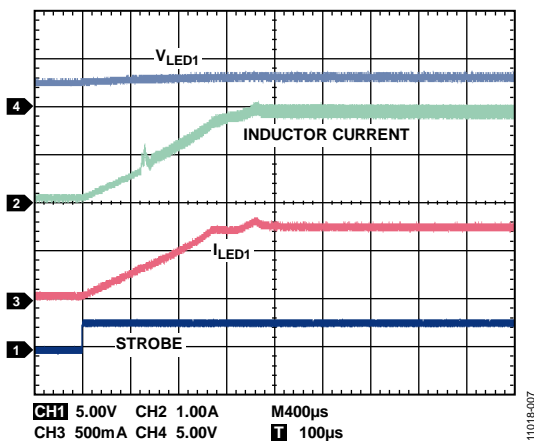

Figure 7. Torch Current to 750 mA Flash Transition, $I_{LED1} = I_{LED2} = 50mA$

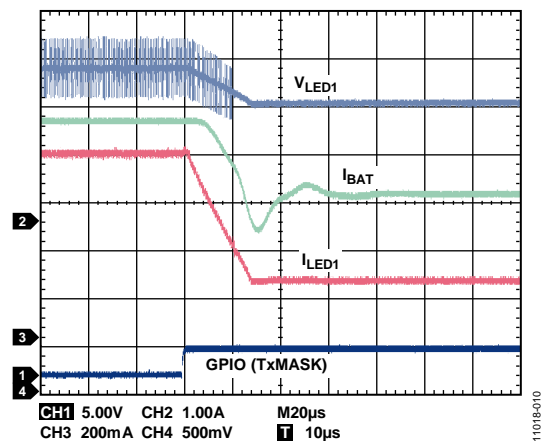

Figure 10. Entry into TxMASK Mode, $I_{LED1} = I_{LED2} = 750mA$ to 250 mA

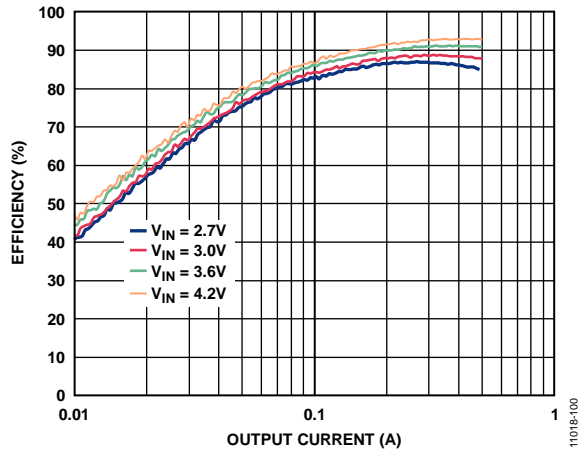

Figure 11. Efficiency vs. Output Current, Fixed 5 V Output Mode

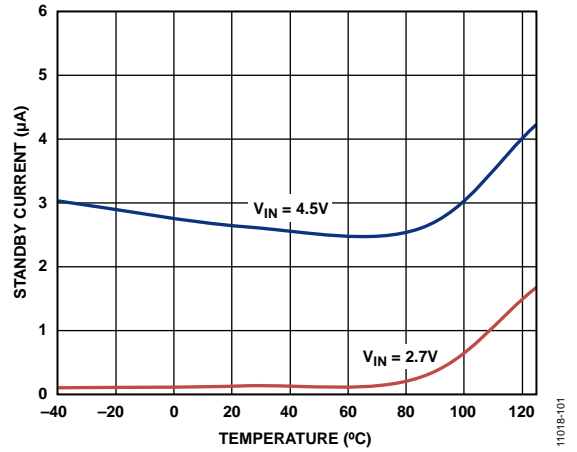

Figure 14. Standby Current vs. Temperature

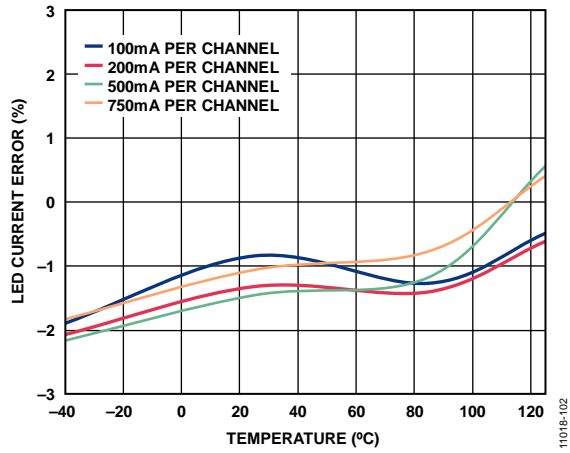

Figure 12. LED Current Error vs. Temperature

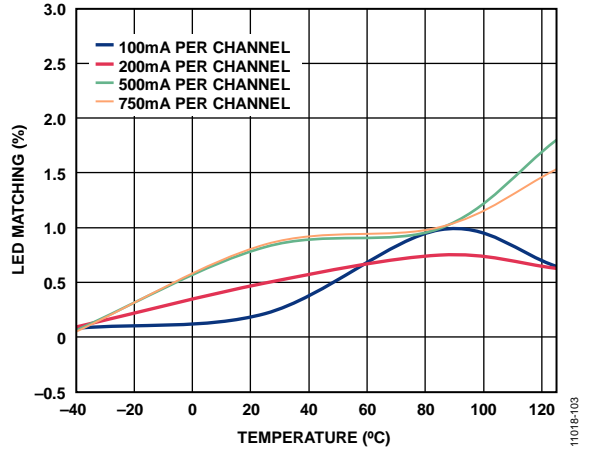

Figure 15. LED Matching vs. Temperature

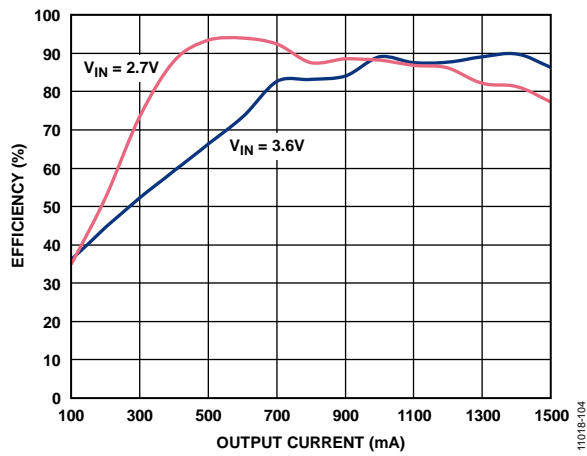

Figure 13. Efficiency (P_{LED}/P_{IN}) vs. LED Output Current

THEORY OF OPERATION

The ADP1660 is a high power, I²C programmable, dual white LED driver ideal for driving white LEDs for use as a camera flash. The ADP1660 includes a boost converter and two current regulators suitable for powering two high power white LEDs.

WHITE LED DRIVER

The ADP1660 drives a synchronous 3 MHz boost converter as required to power the high power LEDs.

- If the sum of the LED forward voltage plus the current source headroom voltage is higher than the battery voltage, the boost converter is turned on.
- If the battery voltage is higher than the sum of the LED forward voltage plus 2× the current source headroom voltage, the boost converter is disabled and the part operates in pass-through mode.

The ADP1660 uses an integrated P-FET high-side current regulator for accurate brightness control.

The ADP1660 supports the setting of different currents for each LED, although this configuration is not recommended. Any mismatch in the forward voltage of the two LEDs translates directly to lower efficiency, as well as lower accuracy of the current for the lower voltage LED. It is recommended that the voltages on the two LEDs be kept within 1 V of one another during operation. The user can disable one LED and use the other LED only, if desired.

MODES OF OPERATION

When the enable pin is high, the I²C-compatible interface can be used to set the ADP1660 to one of seven modes of operation. These modes are configured using the LED_MOD bits (Bits[2:0]) in Register 0x01 (see Table 7).

Table 7. Modes of Operation Set by the LED_MOD Bits

LED_MOD Bits	Operating Mode
000	Standby mode, consuming 3 μ A typical (default)
001	Fixed 5 V output mode
010	Assist light mode with continuous LED current
011	Flash mode with LED currents up to 750 mA available for up to 1.6 sec
100	Independent trigger mode with timeout enabled (LED outputs are disabled if they are on longer than the timer value configured by the FL_TIM bits)
101	Independent trigger mode with timeout disabled (FL_TIM value is ignored)
110	Fixed 5 V output mode with torch mode (total output current must be below 500 mA)
111	Reserved

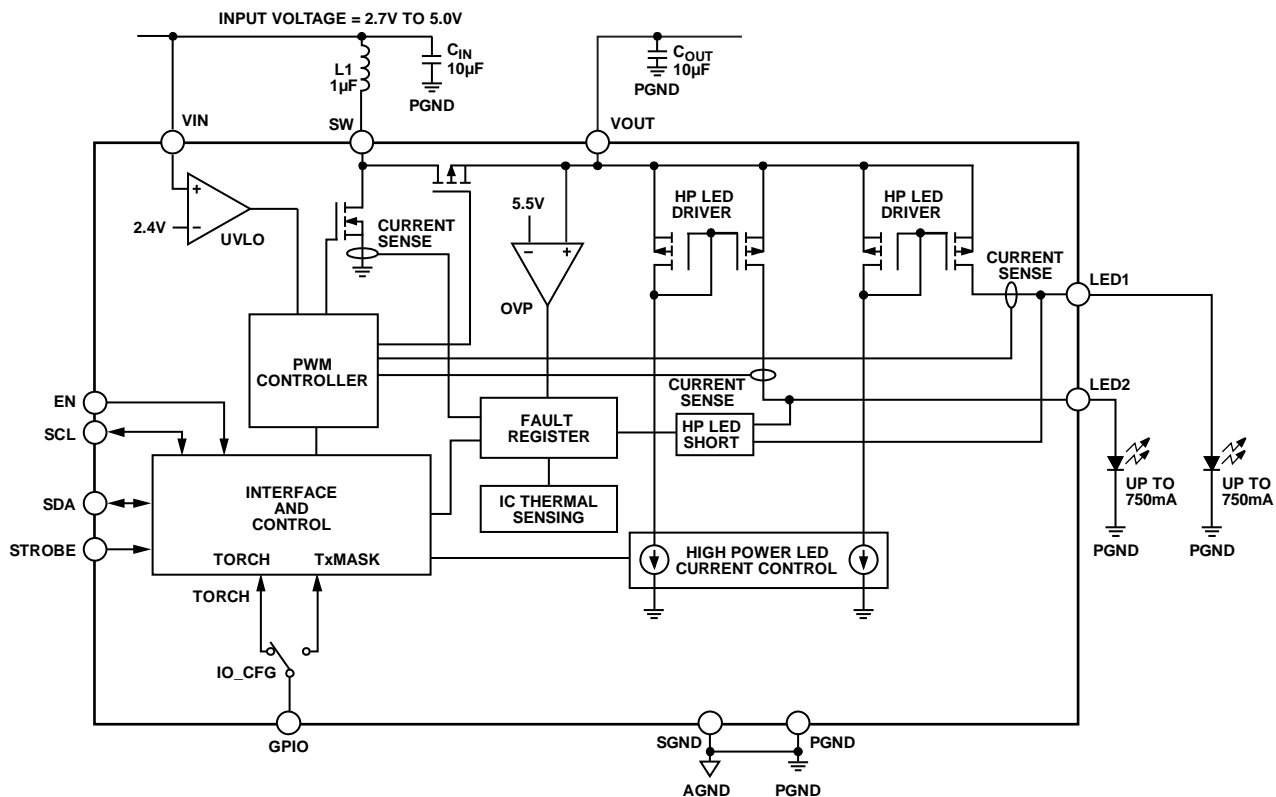

Figure 16. Detailed Block Diagram

ASSIST LIGHT MODE

Assist light mode provides continuous LED current that is programmable from 0 mA to 200 mA. Set the assist light current using the I_TOR1 bits in Register 0x08 (for LED1) and the I_TOR2 bits in Register 0x0B (for LED2).

To enable assist light mode, set the LED_MOD bits to 010 in Register 0x01, and set the LED1_EN and/or LED2_EN bits to 1 in Register 0x0F. To disable assist light mode, set the LED_MOD bits to 000 (standby mode), or set the LED1_EN and LED2_EN bits to 0.

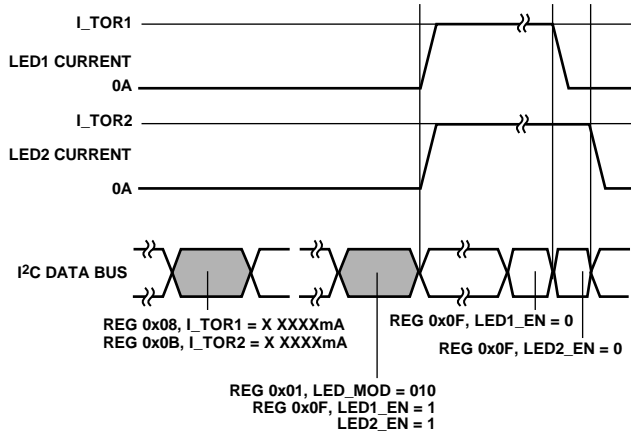

Figure 17. Enabling Assist Light Mode

FLASH MODE

Flash mode provides up to 750 mA per LED for a programmable time of up to 1.6 seconds. Set the flash current using the I_FL1 bits in Register 0x06 (for LED1) and the I_FL2 bits in Register 0x09 (for LED2). Set the maximum flash duration using the FL_TIM bits (Bits[3:0]) in Register 0x02.

To enable flash mode, set the LED_MOD bits to 011 in Register 0x01, and set the LED1_EN and/or LED2_EN bits to 1 in Register 0x0F. If the LED1_EN or LED2_EN bit is set to 0, the corresponding LED will not output current during the flash, regardless of the flash current level setting.

To enable flash mode without using the STROBE pin, set the STR_MOD bit to 0 in Register 0x01 (software strobe mode). When the STR_MOD bit is set to 1 (hardware strobe mode), setting the STROBE pin high enables flash and synchronizes it to the image sensor. Hardware strobe mode has two timeout modes: level sensitive and edge sensitive.

Level-Sensitive STROBE Mode

In level-sensitive mode, the duration of STROBE high sets the duration of the flash up to the maximum time set by the FL_TIM timeout bits in Register 0x02 (see Figure 18). If STROBE is kept high longer than the duration set by the FL_TIM bits, a timeout fault disables the flash. The timeout fault flag (Bit 4) is set in the fault information register (Register 0x0C).

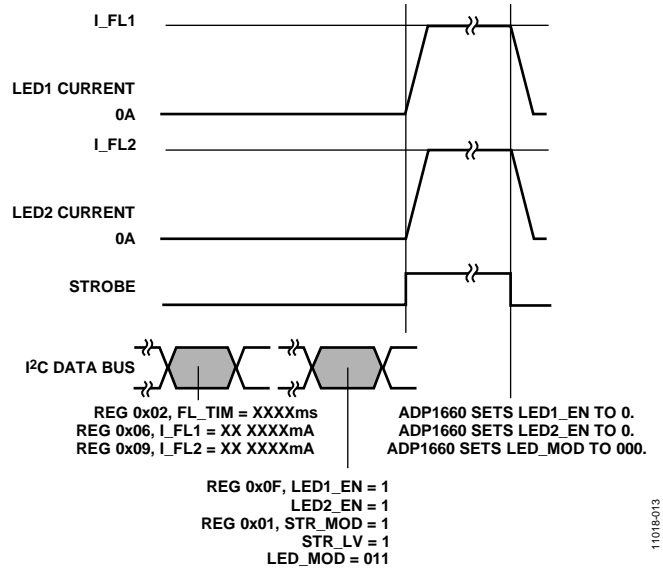

Figure 18. Flash Operation: Level-Sensitive Mode

Edge-Sensitive STROBE Mode

In edge-sensitive mode, a rising edge on the STROBE pin enables the flash, and the FL_TIM bits set the flash duration (see Figure 19).

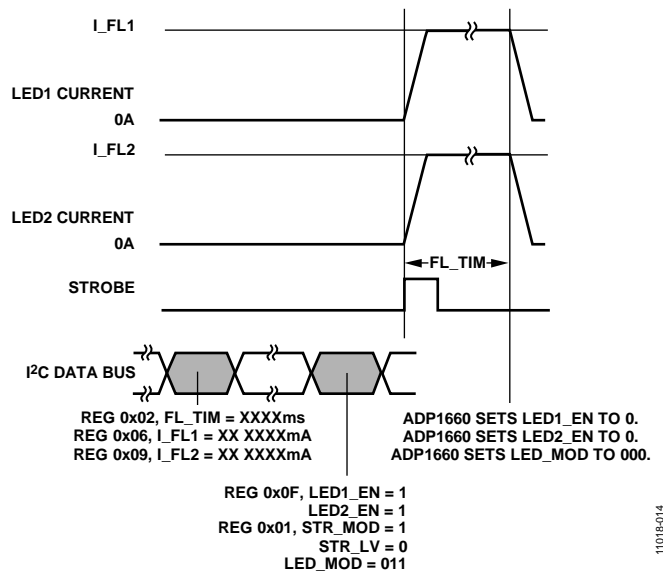

Figure 19. Flash Operation: Edge-Sensitive Mode

ASSIST TO FLASH MODE

The STR_POL bit in Register 0x01 can be used to change the default polarity of the STROBE pin from active high to active low. Additional image sensor-specific assist to flash enable modes are included in the device. Information about these modes is available on request from the Analog Devices, Inc., sales team.

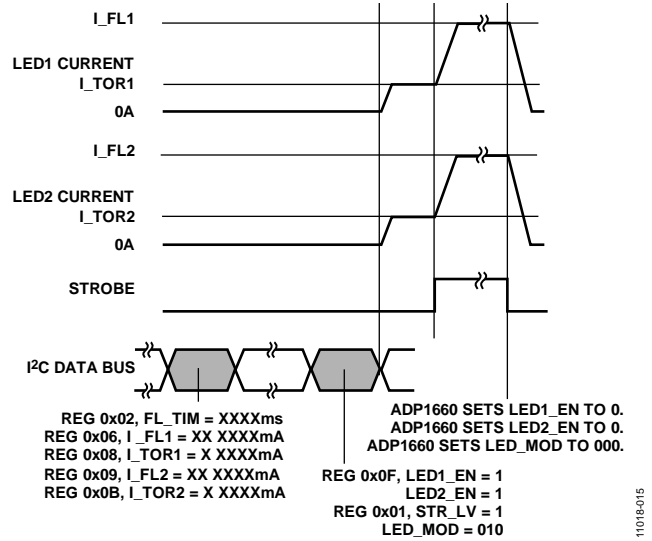

Figure 20. Enabling Assist to Flash (Level-Sensitive) Mode

TORCH MODE

Set the assist/torch light current using the I_TORx bits. To enable torch mode, set the LED_MOD bits to 000 (standby mode), and set the LED1_EN and LED2_EN bits to 1 in Register 0x0F; then bring GPIO high. Disable the LED current by bringing GPIO low or by setting the LED1_EN and LED2_EN bits to 0. Bringing GPIO low during torch mode automatically sets LED1_EN and LED2_EN = 0. To reenale torch mode, set LED1_EN and LED2_EN = 1 and bring GPIO high again.

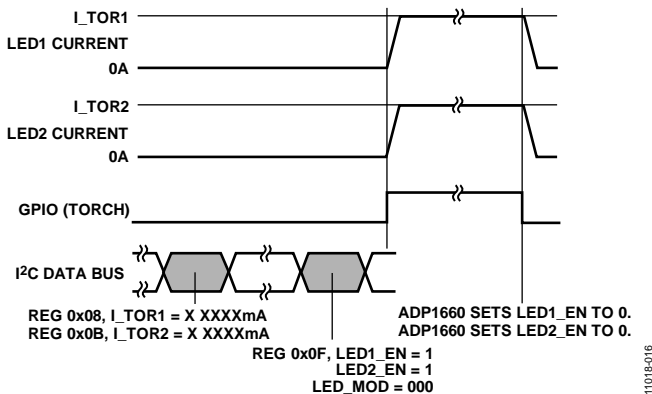

Figure 21. Enabling External Torch Mode Using the GPIO Pin

TORCH TO FLASH MODE

The driver can move directly from external torch mode (using the GPIO pin) to flash mode by bringing the STROBE pin high before GPIO is brought low. Bringing the GPIO (torch) pin low before STROBE goes high prevents the flash from firing.

The ADP1660 returns to standby mode after a successful flash and sets the LED1_EN and LED2_EN bits to 0 in Register 0x0F.

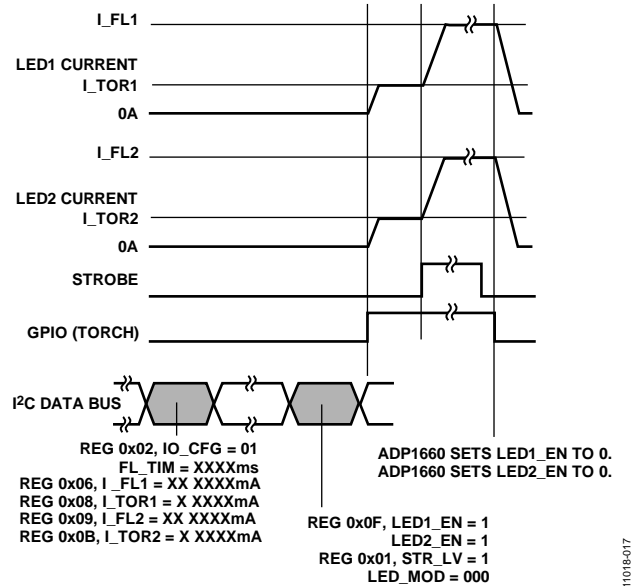

Figure 22. Enabling Flash Mode from External Torch Mode

TxMASK OPERATION

When the ADP1660 is in flash mode, the TxMASK function can reduce the battery load in response to the system enabling a power amplifier. The device remains in flash mode, but the LED driver output current is reduced to the programmed TxMASK current level in less than 21 μs. The TxMASK current level is programmed in Register 0x07 (for LED1) and in Register 0x0A (for LED2).

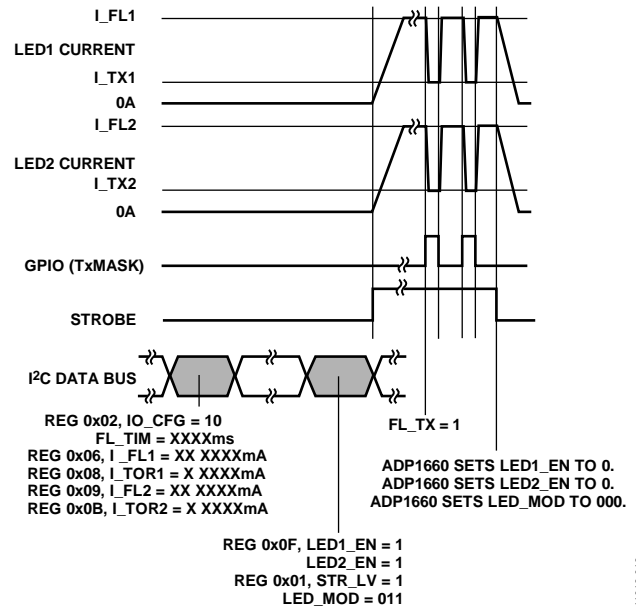

Figure 23. TxMASK Operation During Flash (Level-Sensitive) Mode

After a TxMASK event occurs, a flag is set in the fault information register (Register 0x0C, Bit 3). When the TxMASK signal goes low again, the LED current reverts to the full flash level in a controlled manner to avoid overshoots on the battery current.

INDEPENDENT TRIGGER MODES

When the LED_MOD bits are set to 100 or 101, the ADP1660 allows for independent triggering of each LED at a current level between the configured flash currents and TxMASK currents. In independent trigger mode, the STROBE pin controls LED1, and the GPIO pin controls LED2 (see Figure 24).

- When the STROBE or GPIO pin goes high, the current produced at the LED1 or LED2 pin is at the level specified by the I_FL1 bits (Register 0x06) or the I_FL2 bits (Register 0x09), respectively.
- When the STROBE or GPIO pin goes low, the current produced at the LED1 or LED2 pin is at the level specified by the I_TX1 bits (Register 0x07) or the I_TX2 bits (Register 0x0A), respectively.

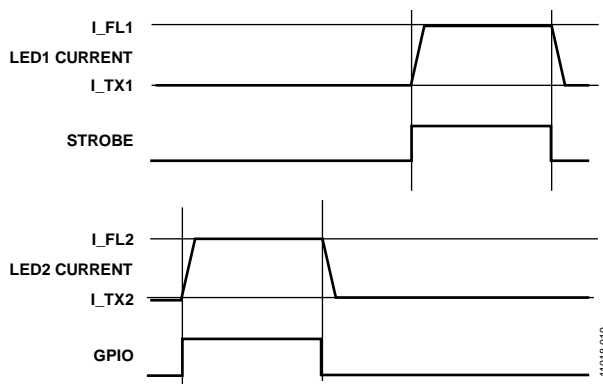

Figure 24. Independent Trigger Mode

When the LED_MOD bits are set to 100, the flash timer is used. If both LEDs are on for a combined time that is equal to the value specified by the FL_TIM bits (both outputs ORed), the ADP1660 sets both LED_ENx bits to 0 and sets LED_MOD to 000.

The independent trigger modes (LED_MOD bits set to 100 or 101) present a possible overtemperature risk; careful evaluation of their implementation must be performed. Before enabling either independent trigger mode, contact your local Analog Devices Field Applications Engineer for assistance.

FIXED 5 V OUTPUT MODE

When the LED_MOD bits are set to 001, the ADP1660 allows VOUT to be regulated to 5 V. In this mode, the total output current must be kept below 500 mA. Enabling one or both LEDs allows low levels of current to the LEDs.

In fixed 5 V output mode, the VOUT pin is connected to the SW node when the ADP1660 is not enabled. Do not connect VOUT directly to a positive external voltage source; doing so causes current to flow from VOUT to the battery. Changing the mode to standby (LED_MOD = 000) ends voltage regulation; VOUT returns to a value that is approximately the same as VIN.

FREQUENCY FOLDBACK

The optional frequency foldback feature optimizes efficiency by reducing the switching frequency to 1.5 MHz when the value of VIN is slightly less than the value of VOUT. To enable frequency foldback, set the FREQ_FB bit to 1 in Register 0x03.

LOW BATTERY LED CURRENT FOLDBACK

As the battery discharges, the lower battery voltage results in higher peak currents through the battery ESR, which may cause early shutdown of other devices on the battery. The ADP1660 includes an optional low battery detection feature, which reduces the flash current to a value from 0 mA to 750 mA when the battery voltage falls below a programmable level. The low battery current level can be set from 0 mA to 750 mA using the I_VB_LO bits (Bits[5:0]) in Register 0x05.

To enable low battery detection and to specify the voltage at which this detection becomes active, set the V_VB_LO bits (Bits[2:0]) in Register 0x04 (see Table 8).

Table 8. VDD Level for Low Battery Detection

V_VB_LO Bit Value	VDD Level for Low Battery Detection (V)
000	Low battery detection disabled (default)
001	3.3
010	3.35
011	3.4
100	3.45
101	3.5
110	3.55
111	3.6

If a low battery fault is detected within a programmed window of detection, the lower current is latched for the remainder of the flash. The window size is specified by the V_BATT_WINDOW bits (Bits[4:3]) in Register 0x04 (see Table 9).

Table 9. Low Battery Detection Window Size

V_BATT_WINDOW Bit Value	Window Size (ms)
00	Window disabled; low battery detection is enabled for the entire flash period
01	1
10	2
11	5 (default)

By reducing the window size to the beginning of the flash only, the user can reduce the chance of partial exposure of the picture in the case that the image sensor is using a rolling scan. If a global scan is used, it is recommended that the low battery detection window be disabled, thereby providing low voltage protection throughout the flash time.

BATTERY INPUT DC CURRENT LIMIT

The ADP1660 has an optional programmable input dc current limit that limits the maximum battery current used over all conditions. This feature allows higher LED currents to be used in a system with significant variation in LED forward voltage (V_F) and supply battery voltage without the risk of exceeding the current allocated to the flash. To enable the input dc current limit, set the IL_DC_EN bit (Bit 0) in Register 0x03. To set the input dc current limit, use the IL_DC bits (Bits[3:1]) in Register 0x03 (see Table 10).

Table 10. Input DC Current Limit

IL_DC Bit Value	DC Current Limit (A)
000	1.0
001	1.25
010	1.5
011	1.75
100	2.0 (default)
101	2.25
110	2.5
111	2.75

During startup of the flash, if the battery current does not exceed the dc current limit, the LED1 and LED2 currents are set to the values of the I_FL1 and I_FL2 bits in Register 0x06 and Register 0x09, respectively.

If the battery current exceeds the programmed dc current limit on startup, the LED current does not increase further. The dc current limit flag is set in the fault information register (Bit 0 of Register 0x0C). The FL_I_FL1 bits in Register 0x0D and the FL_I_FL2 bits in Register 0x0E are set to the actual LED current values and are available for readback.

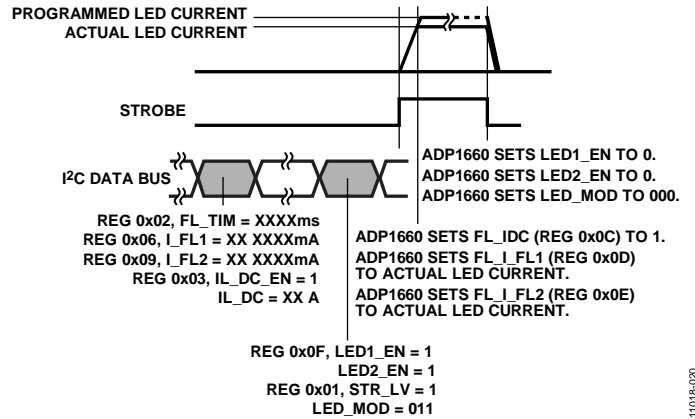

Figure 25. DC Current Limit Operation in a Low Battery, High LED V_F Case

The camera system shown in Figure 26 can adjust the image sensor settings based on the known reduced LED current for a low battery and a high V_F LED.

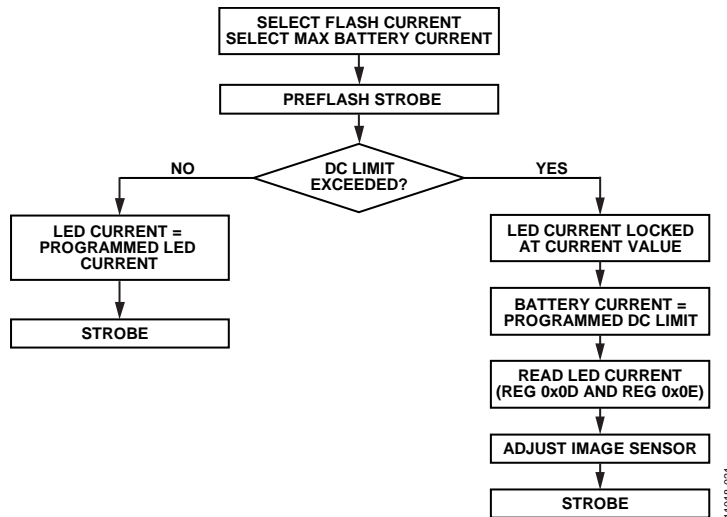

Figure 26. Use of the DC Current Limit in an Optimized Camera System

FIXED 5 V OUTPUT MODE WITH TORCH

The ADP1660 can be used as a 5 V boost converter for a keypad LED driver voltage or an audio voltage rail (see Figure 27 and Figure 28). In this mode, the device supplies up to 500 mA with torch currents available on the LED outputs.

To enable 5 V output voltage mode with torch currents,

1. Set the LED1_EN and LED2_EN bits in Register 0x0F to 0.
2. Enable the 5 V output by setting the LED_MOD bits (Bits[2:0] in Register 0x01) to 110.
3. Enable the LED outputs by setting the LED1_EN and LED2_EN bits to 1.

4. If desired, set the torch/assist currents for the LEDs using Register 0x08 (for LED1) and Register 0x0B (for LED2). These currents can be toggled with the GPIO (torch) pin. If the LED is enabled and the GPIO (torch) pin is low, the LED outputs low levels of current.

The VOUT pin is connected to the SW node when the ADP1660 is not enabled. Do not connect VOUT directly to a positive external voltage source; doing so causes current to flow from VOUT to the battery.

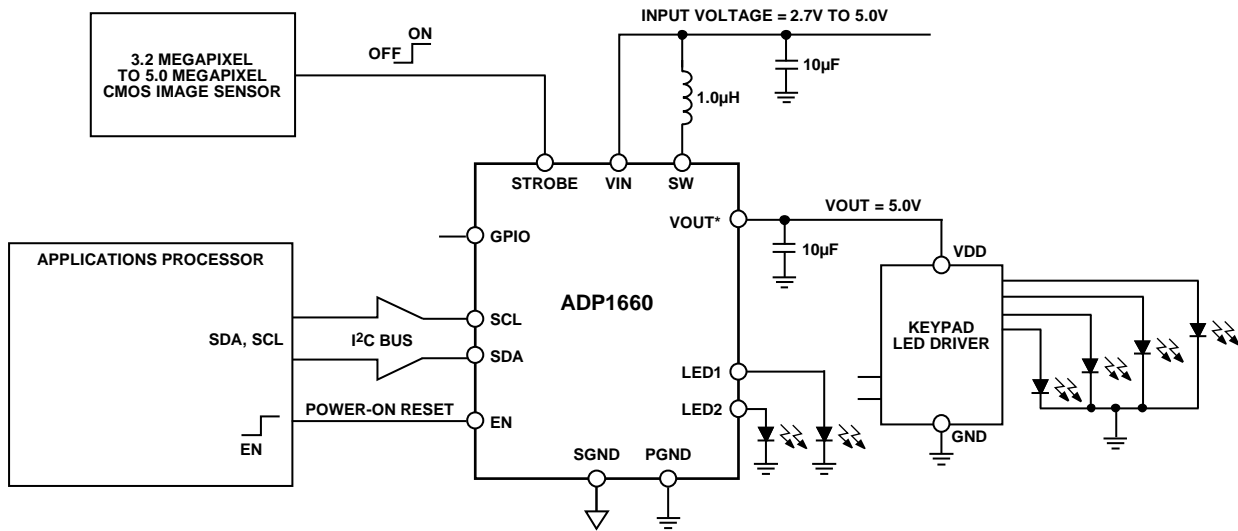

*THE VOUT PIN IS CONNECTED TO THE SW NODE WHEN THE ADP1660 IS NOT ENABLED. VOUT SHOULD NOT BE CONNECTED DIRECTLY TO A POSITIVE EXTERNAL VOLTAGE SOURCE BECAUSE THIS WILL CAUSE CURRENT TO FLOW FROM VOUT TO THE BATTERY.

Figure 27. ADP1660 Voltage Regulation Mode: Keypad LED Driver Application

11018-022

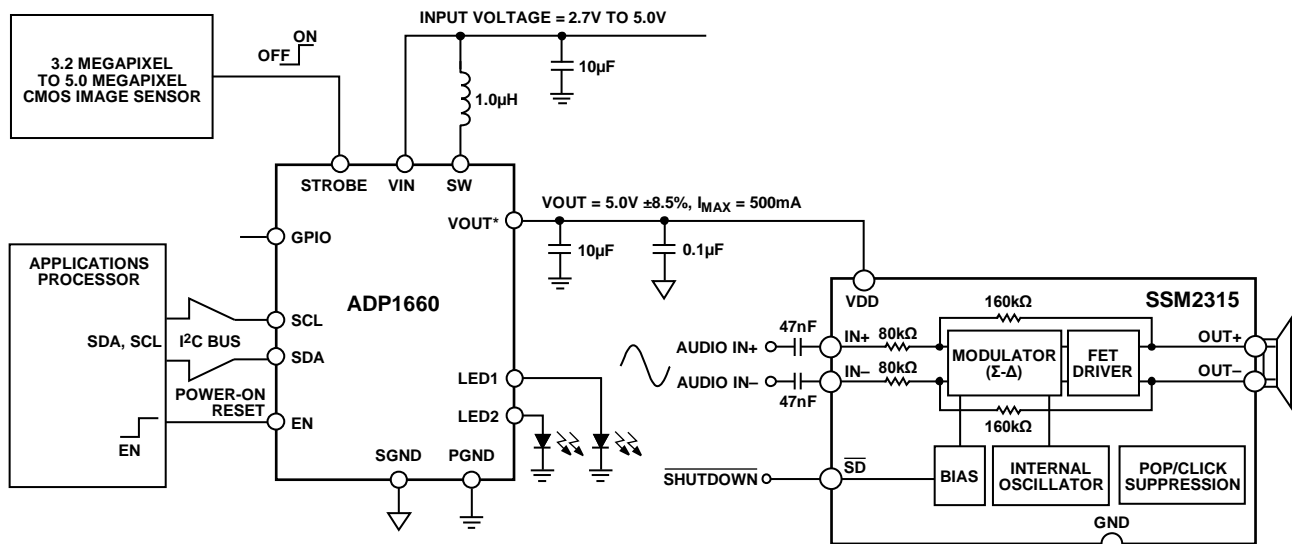

*THE VOUT PIN IS CONNECTED TO THE SW NODE WHEN THE ADP1660 IS NOT ENABLED. VOUT SHOULD NOT BE CONNECTED DIRECTLY TO A POSITIVE EXTERNAL VOLTAGE SOURCE BECAUSE THIS WILL CAUSE CURRENT TO FLOW FROM VOUT TO THE BATTERY.

Figure 28. ADP1660 Voltage Regulation Mode: Class-D Audio Application

11018-023

SAFETY FEATURES

For critical fault conditions—such as output overvoltage, flash timeout, LED output short circuit, and overtemperature conditions—the ADP1660 has built-in protection modes. If a critical fault occurs, the LED1_EN and LED2_EN bits in Register 0x0F are set to 0 and the driver shuts down. The appropriate fault bit is set in the fault information register (Register 0x0C). The processor can read the fault information register through the I²C interface to determine the nature of the fault condition. When the fault register is read, the fault bit is cleared.

If a noncritical event occurs, the LED driver continues to operate. Noncritical events include TxMASK event, dc current limit reached, or soft inductor current limit reached. The corresponding information bits are set in the fault information register (Register 0x0C) until the processor reads them.

SHORT-CIRCUIT FAULT

When the flash driver is disabled, the high-side current regulator disconnects the dc path between the battery and the LED, protecting the system from an LED short circuit. The LED1 and LED2 pins feature short-circuit protection that monitors the LED voltage when the LED driver is enabled. If the voltage on the LED1 or LED2 pin remains below the short-circuit detection threshold, a short circuit is detected, and Bit 6 of the fault information register (Register 0x0C) is set high. The ADP1660 remains disabled until the processor clears the fault register.

OVERVOLTAGE FAULT

The ADP1660 contains a comparator at the VOUT pin that monitors the voltage between VOUT and PGND. If the voltage exceeds 5.5 V (typical), the ADP1660 shuts down. Bit 7 in the fault information register (Register 0x0C) is read back as high. The ADP1660 is disabled until the fault is cleared, ensuring protection against an open circuit, which would cause an overvoltage condition.

DYNAMIC OVERVOLTAGE PROTECTION MODE

Dynamic overvoltage protection (OVP) mode is a programmable feature that prevents the VOUT voltage from exceeding the OVP level while maintaining as much current as possible through the LEDs. Dynamic OVP mode prevents an overvoltage fault in the case of a much higher than expected LED forward voltage. If the LED forward voltage is reduced due to a rise in LED temperature, the ADP1660 transitions out of dynamic OVP mode and regulates the LED at the programmed current level. To enable dynamic OVP mode, set Bit 6 of Register 0x03 high.

TIMEOUT FAULT

If hardware strobe mode is enabled and strobe is set to level-sensitive mode (Register 0x01, Bits[5:4] = 11) and if the STROBE pin remains high for longer than the programmed timeout period, the timeout fault bit (Register 0x0C, Bit 4) is read back as high.

The ADP1660 remains disabled until the processor clears the fault register. The timeout value is set using the FL_TIM bits (Bits[3:0]) in Register 0x02.

OVERTEMPERATURE FAULT

If the junction temperature of the ADP1660 rises above 150°C, a thermal protection circuit shuts down the device. Bit 5 of the fault information register (Register 0x0C) is set high. The ADP1660 remains disabled until the processor clears the fault register.

CURRENT LIMIT

An internal switch limits battery current by ensuring that the peak inductor current does not exceed the limit programmed using Bits[7:6] in Register 0x01. By default, the soft inductor peak current limit mode is disabled (Register 0x03, Bit 7 = 1).

When the soft inductor peak current limit is disabled and the peak inductor current exceeds the limit, Bit 1 of the fault information register (Register 0x0C) is set high. The ADP1660 shuts down and remains disabled until the processor clears the fault register.

When the soft inductor peak current limit is enabled (Register 0x03, Bit 7 = 0) and the peak inductor current reaches the limit, Bit 1 of the fault information register (Register 0x0C) is set high. The inductor and LED current cannot increase further, but the ADP1660 continues to operate.

INPUT UNDERVOLTAGE

The ADP1660 includes a battery undervoltage lockout circuit. During fixed 5 V output or LED operation, if the battery voltage falls below the input UVLO threshold (2.4 V typical), the ADP1660 shuts down. A power-on reset circuit resets the registers to their default values when the voltage rises above the UVLO rising threshold.

SOFT START

The ADP1660 uses a soft start that controls the rate of increase of battery current at startup by digitally controlling the output current ramp. The maximum soft start time is 0.6 ms.

RESET USING THE ENABLE (EN) PIN

A low-to-high transition on the EN pin resets all registers to their default values. Bringing EN low reduces the I_Q to 0.2 μA (typical).

CLEARING FAULTS

The bits in the fault information register (Register 0x0C) are cleared automatically when the processor reads the fault register (provided that the faults no longer exist).

I²C INTERFACE

The ADP1660 includes an I²C-compatible serial interface for control of the LED currents, as well as for readback of system status registers. The I²C chip address is 0x30 (0x60 in write mode and 0x61 in read mode). Additional I²C addresses are available on request.

Figure 29 shows the I²C write sequence for a single register. The subaddress byte selects the register that is written to. The ADP1660 sends an acknowledgment to the master after the 8-bit data byte is written. Figure 30 shows the I²C read sequence for a single register.

For information about the registers and descriptions of all register bits, see the Register Map section.

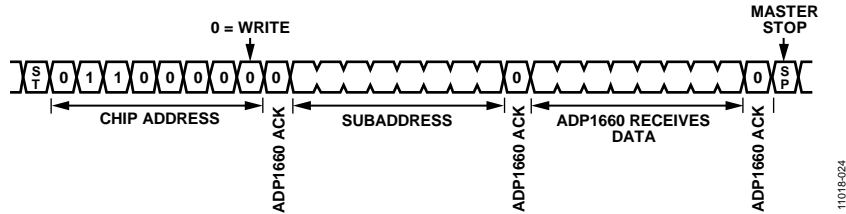

Figure 29. I²C Write Sequence for a Single Register

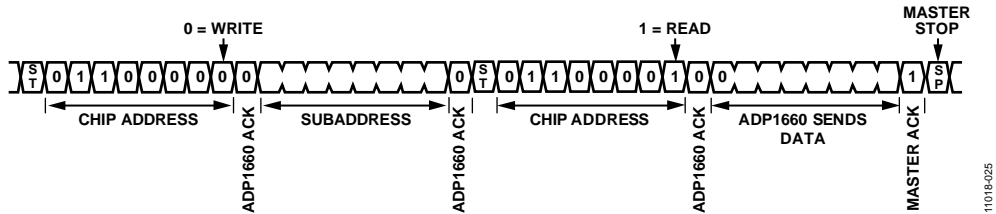

Figure 30. I²C Read Sequence for a Single Register

REGISTER MAP

The highest bit number (7) represents the most significant bit; the lowest bit number (0) represents the least significant bit.

Table 11. Register Map

Address	Register Name	Bit 7	Bit 6	Bit 5	Bit 4	Bit 3	Bit 2	Bit 1	Bit 0	
0x00	Design information	DEVICE_ID					REV_ID			
0x01	Output mode	IL_PEAK		STR_LV	STR_MOD	STR_POL	LED_MOD			
0x02	GPIO and timer	LED_SD	TEST_SR	IO_CFG		FL_TIM				
0x03	Additional features	CL_SOFT	DYN_OVP	SW_LO	FREQ_FB	IL_DC		IL_DC_EN		
0x04	Low battery mode enable	Reserved			V_BATT_WINDOW		V_VB_LO			
0x05	Low battery mode current	Reserved		I_VB_LO						
0x06	LED1 flash current	Reserved		I_FL1						
0x07	LED1 TxMASK current	Reserved		I_TX1						
0x08	LED1 torch/assist current	Reserved			I_TOR1					
0x09	LED2 flash current	Reserved		I_FL2						
0x0A	LED2 TxMASK current	Reserved		I_TX2						
0x0B	LED2 torch/assist current	Reserved			I_TOR2					
0x0C	Fault information	FL_OVP	FL_SC	FL_OT	FL_TO	FL_TX	FL_VB_LO	FL_IL	FL_IDC	
0x0D	LED1 flash current fault readback	Reserved		FL_I_FL1						
0x0E	LED2 flash current fault readback	Reserved		FL_I_FL2						
0x0F	LED enable mode	Reserved						LED2_EN	LED1_EN	

REGISTER DETAILS

Table 12. Design Information Register (Register 0x00)

Bits	Bit Name	Access	Description
[7:3]	DEVICE_ID	R	Device ID for the ADP1660 (00011).
[2:0]	REV_ID	R	Revision ID.

Table 13. Output Mode Register (Register 0x01)

Bits	Bit Name	Access	Description
[7:6]	IL_PEAK	R/W	These bits set the inductor peak current limit. 00 = 2.25 A. 01 = 2.75 A. 10 = 3.25 A (default). 11 = 3.5 A.
5	STR_LV	R/W	This bit sets the sensitivity for the STROBE pin. 0 = edge sensitive. 1 = level sensitive (default).
4	STR_MOD	R/W	This bit sets the strobe mode. 0 = software strobe mode; software flash occurs when the output is enabled in flash mode. 1 = hardware strobe mode; the STROBE pin must go high for flash (default).
3	STR_POL	R/W	This bit sets the polarity of the STROBE pin. 0 = active low. 1 = active high (default).
[2:0]	LED_MOD	R/W	These bits set the LED output mode. 000 = standby mode (default). 001 = fixed 5 V output mode. 010 = assist light mode. 011 = flash mode. 100 = independent trigger mode with timeout enabled. 101 = independent trigger mode with timeout disabled. 110 = fixed 5 V output mode with torch mode (total output current must be below 500 mA). 111 = reserved.

Table 14. GPIO and Timer Register (Register 0x02)

Bits	Bit Name	Access	Description
7	LED_SD	R/W	This bit configures the shutdown function for LED1 and LED2. 0 = enter shutdown after LED1 or LED2 flash or torch ends (default). 1 = do not enter shutdown after LED1 or LED2 flash or torch ends.
6	TEST_SR	R/W	Test mode only. This bit must be set to its default value, 1. Do not set this bit to 0.
[5:4]	IO_CFG	R/W	These bits configure the GPIO pin. 00 = high impedance (default). 01 = torch mode. 10 = TxMASK operation mode. 11 = torch mode without the 8 ms deglitch filter.
[3:0]	FL_TIM	R/W	These bits set the flash timer value. 0000 = 100 ms. 0001 = 200 ms. ... 0100 = 500 ms. ... 0110 = 700 ms. ... 1001 = 1000 ms. ... 1100 = 1300 ms. ... 1111 = 1600 ms (default).

Table 15. Additional Features Register (Register 0x03)

Bits	Bit Name	Access	Description
7	CL_SOFT	R/W	This bit enables or disables the soft inductor peak current limit. 0 = enable soft inductor peak current limit. 1 = disable soft inductor peak current limit (default). The ADP1660 is disabled when the inductor peak current limit is reached.
6	DYN_OVP	R/W	This bit enables or disables dynamic OVP. 0 = disable dynamic OVP (default). 1 = enable dynamic OVP.
5	SW_LO	R/W	This bit sets the switching frequency. 0 = 3 MHz (default). 1 = 1.5 MHz.
4	FREQ_FB	R/W	This bit enables or disables frequency foldback to 1.5 MHz. 0 = disable frequency foldback (default). 1 = enable frequency foldback.
[3:1]	IL_DC	R/W	These bits set the input dc current limit. (Bit 0 must be set to 1.) 000 = 1.0 A. 001 = 1.25 A. 010 = 1.5 A. 011 = 1.75 A. 100 = 2.0 A (default). 101 = 2.25 A. 110 = 2.5 A. 111 = 2.75 A.
0	IL_DC_EN	R/W	This bit enables or disables the input dc current limit function. 0 = disable input dc current limit (default). 1 = enable input dc current limit.

Table 16. Low Battery Mode Enable Register (Register 0x04)

Bits	Bit Name	Access	Description
[7:5]	Reserved	R/W	Reserved.
[4:3]	V_BATT_WINDOW	R/W	These bits set the window size for low battery detection mode. 00 = window disabled; low battery detection is enabled for the entire flash period. 01 = window enabled for 1 ms. 10 = window enabled for 2 ms. 11 = window enabled for 5 ms (default).
[2:0]	V_VB_LO	R/W	These bits enable or disable low battery detection and set the battery voltage level at which the low battery detection function is enabled. 000 = low battery detection disabled (default). 001 = low battery detection enabled at 3.3 V. 010 = low battery detection enabled at 3.35 V. 011 = low battery detection enabled at 3.4 V. 100 = low battery detection enabled at 3.45 V. 101 = low battery detection enabled at 3.5 V. 110 = low battery detection enabled at 3.55 V. 111 = low battery detection enabled at 3.6 V.

Table 17. Low Battery Mode Current Register (Register 0x05)

Bits	Bit Name	Access	Description
[7:6]	Reserved	R/W	Reserved.
[5:0]	I_VB_LO	R/W	These bits set the flash current value for the low battery voltage setting. The current setting is equal to the value of these six bits multiplied by 12.5 mA ($I_{VB_LO} \times 12.5$). The maximum current value is 750 mA. 00 0000 = 0 mA. 00 0001 = 12.5 mA. ... 00 1000 = 100 mA. ... 01 0100 = 250 mA. ... 10 1000 = 500 mA (default). ... 11 1100 = 750 mA. ... 11 1111 = 750 mA.

Table 18. LED1 Flash Current Register (Register 0x06)

Bits	Bit Name	Access	Description
[7:6]	Reserved	R/W	Reserved.
[5:0]	I_FL1	R/W	These bits set the flash current value for LED1. The current setting is equal to the value of these six bits multiplied by 12.5 mA ($I_{FL1} \times 12.5$). The maximum current value is 750 mA. 00 0000 = 0 mA. 00 0001 = 12.5 mA. ... 00 1000 = 100 mA. ... 01 0100 = 250 mA. ... 10 1000 = 500 mA (default). ... 11 1100 = 750 mA. ... 11 1111 = 750 mA.

Table 19. LED1 TxMASK Current Register (Register 0x07)

Bits	Bit Name	Access	Description
[7:6]	Reserved	R/W	Reserved.
[5:0]	I_TX1	R/W	These bits set the TxMASK current value for LED1. The current setting is equal to the value of these six bits multiplied by 12.5 mA ($I_{TX1} \times 12.5$). The maximum TxMASK current value is 750 mA. 00 0000 = 0 mA. 00 0001 = 12.5 mA. ... 00 1000 = 100 mA. ... 01 0100 = 250 mA (default). ... 10 1000 = 500 mA. ... 11 1100 = 750 mA. ... 11 1111 = 750 mA.

Table 20. LED1 Torch/Assist Current Register (Register 0x08)

Bits	Bit Name	Access	Description
[7:5]	Reserved	R/W	Reserved.
[4:0]	I_TOR1	R/W	These bits set the torch/assist current value for LED1. The current setting is equal to the value of these five bits multiplied by 12.5 mA ($I_{TOR1} \times 12.5$). The maximum current value is 200 mA. 0 0000 = 0 mA. ... 0 0100 = 50 mA (default). ... 0 1000 = 100 mA. ... 0 1100 = 150 mA. ... 1 0000 = 200 mA. ... 1 1111 = 200 mA.

Table 21. LED2 Flash Current Register (Register 0x09)

Bits	Bit Name	Access	Description
[7:6]	Reserved	R/W	Reserved.
[5:0]	I_FL2	R/W	These bits set the flash current value for LED2. The current setting is equal to the value of these six bits multiplied by 12.5 mA ($I_{FL2} \times 12.5$). The maximum current value is 750 mA. 00 0000 = 0 mA. 00 0001 = 12.5 mA. ... 00 1000 = 100 mA. ... 01 0100 = 250 mA. ... 10 1000 = 500 mA (default). ... 11 1100 = 750 mA. ... 11 1111 = 750 mA.

Table 22. LED2 TxMASK Current Register (Register 0x0A)

Bits	Bit Name	Access	Description
[7:6]	Reserved	R/W	Reserved.
[5:0]	I_TX2	R/W	These bits set the TxMASK current value for LED2. The current setting is equal to the value of these six bits multiplied by 12.5 mA ($I_TX2 \times 12.5$). The maximum TxMASK current value is 750 mA. 00 0000 = 0 mA. 00 0001 = 12.5 mA. ... 00 1000 = 100 mA. ... 01 0100 = 250 mA (default). ... 10 1000 = 500 mA. ... 11 1100 = 750 mA. ... 11 1111 = 750 mA.

Table 23. LED2 Torch/Assist Current Register (Register 0x0B)

Bits	Bit Name	Access	Description
[7:5]	Reserved	R/W	Reserved.
[4:0]	I_TOR2	R/W	These bits set the torch/assist current value for LED2. The current setting is equal to the value of these five bits multiplied by 12.5 mA ($I_TOR2 \times 12.5$). The maximum current value is 200 mA. 0 0000 = 0 mA. ... 0 0100 = 50 mA (default). ... 0 1000 = 100 mA. ... 0 1100 = 150 mA. ... 1 0000 = 200 mA. ... 1 1111 = 200 mA.

Table 24. Fault Information Register (Register 0x0C)

Bits	Bit Name	Access	Description
7	FL_OVP	R	0 = no overvoltage fault (default). 1 = overvoltage fault.
6	FL_SC	R	0 = no short-circuit fault (default). 1 = short-circuit fault.
5	FL_OT	R	0 = no overtemperature fault (default). 1 = overtemperature fault.
4	FL_TO	R	0 = no timeout fault (default). 1 = timeout fault.
3	FL_TX	R	0 = no TxMASK operation mode during last flash (default). 1 = TxMASK operation mode occurred during last flash.
2	FL_VB_LO	R	Low battery detection threshold status; low battery detection must be enabled in Register 0x04. 0 = V_{DD} is greater than the configured low battery threshold (default). 1 = V_{DD} is less than the configured low battery threshold.
1	FL_IL	R	0 = no inductor peak current limit fault (default). 1 = inductor peak current limit fault.
0	FL_IDC	R	DC current limit threshold status; dc current limit must be enabled in Register 0x03. 0 = dc current limit not reached (default). 1 = dc current limit reached.

Table 25. LED1 Flash Current Fault Readback Register (Register 0x0D)

Bits	Bit Name	Access	Description
[7:6]	Reserved	R	Reserved.
[5:0]	FL_I_FL1	R	These bits contain the flash current value for LED1 when the dc current limit fault occurs. The current setting is equal to the value of these six bits multiplied by 12.5 mA ($FL_I_FL1 \times 12.5$). 00 0000 = 0 mA. 00 0001 = 12.5 mA. ... 00 1000 = 100 mA. ... 01 0100 = 250 mA. ... 10 1000 = 500 mA. ... 11 1100 = 750 mA.

Table 26. LED2 Flash Current Fault Readback Register (Register 0x0E)

Bits	Bit Name	Access	Description
[7:6]	Reserved	R	Reserved.
[5:0]	FL_I_FL2	R	These bits contain the flash current value for LED2 when the dc current limit fault occurs. The current setting is equal to the value of these six bits multiplied by 12.5 mA ($FL_I_FL2 \times 12.5$). 00 0000 = 0 mA. 00 0001 = 12.5 mA. ... 00 1000 = 100 mA. ... 01 0100 = 250 mA. ... 10 1000 = 500 mA. ... 11 1100 = 750 mA.

Table 27. LED Enable Mode Register (Register 0x0F)

Bits	Bit Name	Access	Description
[7:2]	Reserved	R/W	Reserved.
1	LED2_EN	R/W	This bit enables or disables the LED2 output. 0 = disable LED2 output (default). 1 = enable LED2 output. To enable both channels at once, set both LED2_EN and LED1_EN to 0 and then set both bits to 1 in the same I ² C write command. If LED1 is already enabled and the user tries to set the LED2_EN bit to 1, this write is ignored.
0	LED1_EN	R/W	This bit enables or disables the LED1 output. 0 = disable LED1 output (default). 1 = enable LED1 output. To enable both channels at once, set both LED1_EN and LED2_EN to 0 and then set both bits to 1 in the same I ² C write command. If LED2 is already enabled and the user tries to set the LED1_EN bit to 1, this write is ignored.

APPLICATIONS INFORMATION

EXTERNAL COMPONENT SELECTION

Selecting the Inductor

The ADP1660 boost converter increases the battery voltage to allow driving of two LEDs when the forward voltage of the LEDs is higher than the battery voltage minus $2 \times$ the current source headroom voltage. This allows the converter to regulate the LED current over the entire battery voltage range and with a wide variation of LED forward voltages.

The inductor saturation current should be greater than the sum of the dc input current and half the inductor ripple current. A reduction in the effective inductance due to saturation increases the inductor ripple current. Table 28 provides a list of suggested inductors.

Table 28. Suggested Inductors

Vendor	Value (μH)	Part No.	DCR ($\text{m}\Omega$)	I_{SAT} (A)	Dimensions $L \times W \times H$ (mm)
Toko	1.0	FDSD0312	43	4.5	$3.0 \times 3.0 \times 1.2$
Toko	1.0	DFE2520	50	3.4	$2.5 \times 2.0 \times 1.0$
Coilcraft	1.0	XFL3010	43	2.4	$3.0 \times 3.0 \times 1.0$
Murata	1.0	LQM32P_GO	48	3	$3.2 \times 2.5 \times 1.0$
FDK	1.0	MIP3226D	40	3	$3.2 \times 2.6 \times 1.0$

Selecting the Input Capacitor

The ADP1660 requires an input bypass capacitor to supply transient currents while maintaining constant input and output voltages. The input capacitor carries the input ripple current, allowing the input power source to supply only the dc current. Increased input capacitance reduces the amplitude of the switching frequency ripple on the battery. Due to the dc bias characteristics of ceramic capacitors, the recommended capacitor is a $10.0 \mu\text{F}$, 6.3 V, X5R/X7R ceramic capacitor.

Higher input capacitor values help to reduce the input voltage ripple and improve transient response.

To minimize supply noise, place the input capacitor as close to the VIN pin of the ADP1660 as possible. A low ESR capacitor is required. Table 29 provides a list of suggested input and output capacitors.

Table 29. Suggested Input and Output Capacitors

Vendor	Value	Part No.	Dimensions $L \times W \times H$ (mm)
Murata	$10 \mu\text{F}$, 6.3 V	GRM188R60J106ME47	$1.6 \times 0.8 \times 0.8$
TDK	$10 \mu\text{F}$, 6.3 V	C1608JB0J106K	$1.6 \times 0.8 \times 0.8$
Taiyo Yuden	$10 \mu\text{F}$, 6.3 V	JMK107BJ106MA	$1.6 \times 0.8 \times 0.8$

Selecting the Output Capacitor

The output capacitor maintains the output voltage and supplies the LED current during the on period of the N-FET power switch. It also stabilizes the loop. The recommended capacitor is a $10.0 \mu\text{F}$, 6.3 V, X5R/X7R ceramic capacitor (see Table 29).

Note that dc bias characterization data is available from capacitor manufacturers and should be taken into account when selecting input and output capacitors. Capacitors of 6.3 V or 10 V are best for most designs.

Higher output capacitor values reduce the output voltage ripple and improve load transient response. When selecting an output capacitor value, it is also important to account for the loss of capacitance due to output voltage dc bias.

Ceramic capacitors have a variety of dielectrics, each with different behavior over temperature and applied voltage. Capacitors must have a dielectric that ensures the minimum capacitance over the necessary temperature range and dc bias conditions. X5R or X7R dielectrics with a voltage rating of 6.3 V or 10 V are recommended for best performance. Y5V and Z5U dielectrics are not recommended for use with any dc-to-dc converter because of their poor temperature and dc bias characteristics.

The worst-case capacitance accounting for capacitor variation over temperature, component tolerance, and voltage is calculated using the following equation:

$$C_{\text{EFF}} = C_{\text{OUT}} \times (1 - \text{TEMPCO}) \times (1 - \text{TOL})$$

where:

C_{EFF} is the effective capacitance at the operating voltage.

TEMPCO is the worst-case capacitor temperature coefficient.

TOL is the worst-case component tolerance.

For example, a $10 \mu\text{F}$, X5R capacitor has the following characteristics:

TEMPCO from -40°C to $+85^\circ\text{C}$ is 15%.

TOL is 10%.

C_{OUT} at $V_{\text{OUT (MAX)}} = 5 \text{ V}$ is $3 \mu\text{F}$ (see Figure 31).

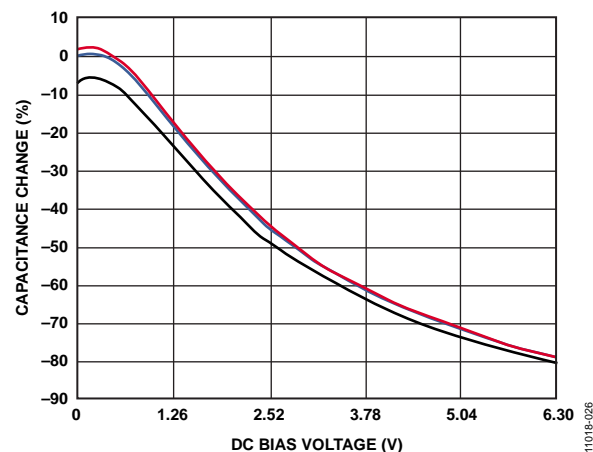

Figure 31. DC Bias Characteristic of a $10 \mu\text{F}$, 6.3 V Ceramic Capacitor

Substituting these values in the equation yields

$$C_{\text{EFF}} = 3 \mu\text{F} \times (1 - 0.15) \times (1 - 0.1) = 2.3 \mu\text{F}$$

The effective capacitance needed for stability, which includes temperature and dc bias effects, is $3.0 \mu\text{F}$.

PCB LAYOUT

Poor layout can affect performance, causing electromagnetic interference (EMI) and electromagnetic compatibility (EMC) problems, ground bounce, and power losses. Poor layout can also affect regulation and stability. Figure 32 shows an optimized layout implemented using the following guidelines:

- Place the inductor, input capacitor, and output capacitor close to the IC using short tracks. These components carry high switching frequencies and large currents.
- Use as wide a trace as possible between the inductor and the SW pin. The easiest path for this trace is through the center of the output capacitor.
- Route the LED1/LED2 path away from the inductor and SW node to minimize noise and magnetic interference.
- Maximize the size of ground metal on the component side of the board to help with thermal dissipation.
- Use a ground plane with two or three vias connecting to the component side ground near the output capacitor to reduce noise interference on sensitive circuit nodes.

Analog Devices applications engineers can be contacted through the Analog Devices sales team to discuss different layouts based on system design constraints.

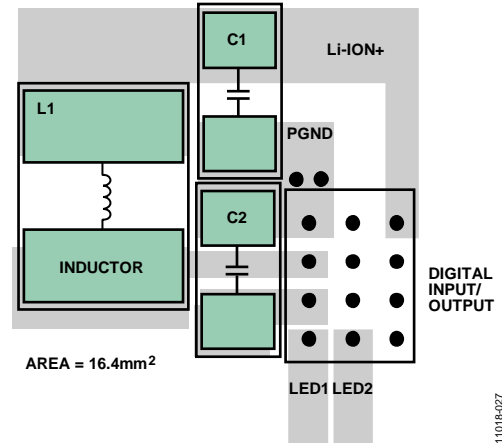

Figure 32. Layout of the ADP1660 Driving a High Power White LED

OUTLINE DIMENSIONS

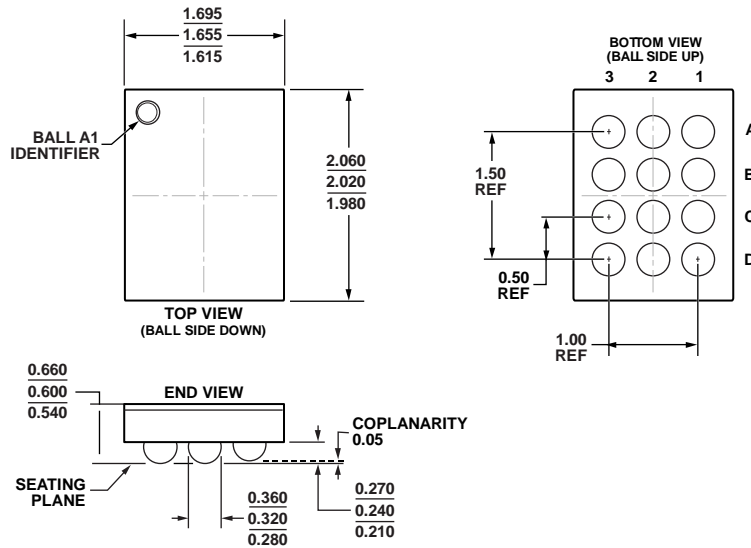

Figure 33. 12-Ball Wafer Level Chip Scale Package [WLCSP] (CB-12-7)
Dimensions shown in millimeters

09-07-2012-A

ORDERING GUIDE

Model ¹	Temperature Range	Package Description	Package Option ²	Branding
ADP1660ACBZ-R7	-40°C to +125°C	12-Ball Wafer Level Chip Scale Package [WLCSP]	CB-12-7	LM7
ADP1660CB-EVALZ		Evaluation Board		

¹ Z = RoHS Compliant Part.

² This package option is halide free.

NOTES

NOTES

I²C refers to a communications protocol originally developed by Philips Semiconductors (now NXP Semiconductors).

Компания «Life Electronics» занимается поставками электронных компонентов импортного и отечественного производства от производителей и со складов крупных дистрибьюторов Европы, Америки и Азии.

С конца 2013 года компания активно расширяет линейку поставок компонентов по направлению коаксиальный кабель, кварцевые генераторы и конденсаторы (керамические, пленочные, электролитические), за счёт заключения дистрибьюторских договоров

Мы предлагаем:

- Конкуренспособные цены и скидки постоянным клиентам.
- Специальные условия для постоянных клиентов.
- Подбор аналогов.
- Поставку компонентов в любых объемах, удовлетворяющих вашим потребностям.
- Приемлемые сроки поставки, возможна ускоренная поставка.
- Доставку товара в любую точку России и стран СНГ.
- Комплексную поставку.
- Работу по проектам и поставку образцов.
- Формирование склада под заказчика.
- Сертификаты соответствия на поставляемую продукцию (по желанию клиента).
- Тестирование поставляемой продукции.
- Поставку компонентов, требующих военную и космическую приемку.
- Входной контроль качества.
- Наличие сертификата ISO.

В составе нашей компании организован Конструкторский отдел, призванный помогать разработчикам, и инженерам.

Конструкторский отдел помогает осуществить:

- Регистрацию проекта у производителя компонентов.
- Техническую поддержку проекта.
- Защиту от снятия компонента с производства.
- Оценку стоимости проекта по компонентам.
- Изготовление тестовой платы монтаж и пусконаладочные работы.



Тел: +7 (812) 336 43 04 (многоканальный)

Email: org@lifeelectronics.ru