



Micropower, Low Noise Precision Voltage References with Shutdown

ADR391/ADR392/ADR395

FEATURES

- Compact 5-lead TSOT package
- Low temperature coefficient
 - B grade: 9 ppm/°C
 - A grade: 25 ppm/°C
- Initial accuracy
 - B grade: ±4 mV maximum (ADR391)
 - A grade: ±6 mV maximum
- Ultralow output noise: 5 μ V p-p (0.1 Hz to 10 Hz)
- Low dropout: 300 mV
- Low supply current
 - 3 μ A maximum in shutdown
 - 140 μ A maximum in operation
- No external capacitor required
- Output current: 5 mA
- Automotive grade available
- Wide temperature range: -40°C to +125°C

APPLICATIONS

- Battery-powered instrumentation
- Portable medical instrumentation
- Data acquisition systems
- Industrial process controls
- Automotive

GENERAL DESCRIPTION

The ADR391/ADR392/ADR395 are precision 2.048 V, 2.5 V, 4.096 V, and 5 V band gap voltage references, respectively, featuring low power and high precision in a tiny footprint. Using patented temperature drift curvature correction techniques from Analog Devices, Inc., the ADR39x references achieve a low 9 ppm/°C of temperature drift in the TSOT package.

PIN CONFIGURATION

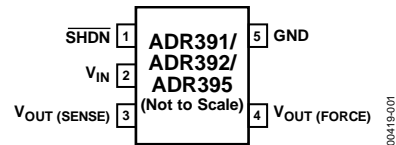

Figure 1. 5-Lead TSOT (UJ Suffix)

Table 1.

Model	Output Voltage (Vo)	Temperature Coefficient (ppm/°C)	Accuracy (mV)
ADR391B	2.5	9	±4
ADR391A	2.5	25	±6
ADR392B	4.096	9	±5
ADR392A	4.096	25	±6
ADR395B	5.0	9	±5
ADR395A	5.0	25	±6

The ADR39x family of micropower, low dropout voltage references provides a stable output voltage from a minimum supply of 300 mV above the output. Their advanced design eliminates the need for external capacitors, which further reduces board space and system cost. The combination of low power operation, small size, and ease of use makes the ADR39x precision voltage references ideally suited for battery-operated applications.

Rev. H

Information furnished by Analog Devices is believed to be accurate and reliable. However, no responsibility is assumed by Analog Devices for its use, nor for any infringements of patents or other rights of third parties that may result from its use. Specifications subject to change without notice. No license is granted by implication or otherwise under any patent or patent rights of Analog Devices. Trademarks and registered trademarks are the property of their respective owners.

TABLE OF CONTENTS

Features	1
Applications	1
Pin Configuration	1
General Description	1
Revision History	2
Specifications	3
ADR391 Electrical Characteristics	3
ADR392 Electrical Characteristics	4
ADR395 Electrical Characteristics	5
Absolute Maximum Ratings	6
Thermal Resistance	6

REVISION HISTORY

10/09—Rev. G to Rev. H

Deleted ADR390	Universal
Changes to Ordering Guide Section	18

2/08—Rev. F to Rev. G

Changes to Ripple Rejection Ratio Parameter (Table 2)	3
Changes to Ripple Rejection Ratio Parameter (Table 3)	4
Changes to Ripple Rejection Ratio Parameter (Table 4)	5
Changes to Ripple Rejection Ratio Parameter (Table 5)	6
Changes to Figure 7	9
Changes to Outline Dimensions	19
Changes to Ordering Guide	19

5/05—Rev. E to Rev. F

Changes to Table 5	7
Changes to Figure 2	9

4/04—Rev. D to Rev. E

Changes to ADR390—Specifications	3
Changes to ADR391—Specifications	4
Changes to ADR392—Specifications	5
Changes to ADR395—Specifications	6

4/04—Rev. C to Rev. D

Updated Format	Universal
Changes to Title	1
Changes to Features	1
Changes to Applications	1
Changes to General Description	1
Changes to Table 1	1
Changes to ADR390—Specifications	3
Changes to ADR391—Specifications	4

ESD Caution	6
Typical Performance Characteristics	7
Terminology	13
Theory of Operation	14
Device Power Dissipation Considerations	14
Shutdown Mode Operation	14
Applications Information	15
Basic Voltage Reference Connection	15
Capacitors	17
Outline Dimensions	18
Ordering Guide	18

Changes to ADR392—Specifications	5
Changes to ADR395—Specifications	6
Changes to Absolute Maximum Ratings	7
Changes to Thermal Resistance	7
Moved ESD Caution	7
Changes to Figure 3, Figure 4, Figure 7, and Figure 8	9
Changes to Figure 11, Figure 12, Figure 13, and Figure 14	10
Changes to Figure 15, Figure 16, Figure 19, and Figure 20	11
Changes to Figure 23 and Figure 24	12
Changes to Figure 27	13
Changes to Ordering Guide	19
Updated Outline Dimensions	19

10/02—Rev. B to Rev. C

Add parts ADR392 and ADR395	Universal
Changes to Features	1
Changes to General Description	1
Additions to Table I	1
Changes to Specifications	2
Changes to Ordering Guide	4
Changes to Absolute Maximum Ratings	4
New TPCs 3, 4, 7, 8, 11, 12, 15, 16, 19, and 20	6
New Figures 4 and 5	13
Deleted A Negative Precision Reference without Precision Resistors Section	13
Edits to General-Purpose Current Source Section	13
Updated Outline Dimensions	15

5/02—Rev. A to Rev. B

Edits to Layout	Universal
Changes to Figure 6	13

SPECIFICATIONS

ADR391 ELECTRICAL CHARACTERISTICS

$V_{IN} = 2.8\text{ V to }15\text{ V}$, $T_A = 25^\circ\text{C}$, unless otherwise noted.

Table 2.

Parameter	Symbol	Conditions	Min	Typ	Max	Unit
OUTPUT VOLTAGE	V_O	A grade	2.494	2.5	2.506	V
		B grade	2.496	2.5	2.504	V
INITIAL ACCURACY	V_{OERR}	A grade			6	mV
		A grade			0.24	%
		B grade			4	mV
		B grade			0.16	%
TEMPERATURE COEFFICIENT	TCV_O	A grade, $-40^\circ\text{C} < T_A < +125^\circ\text{C}$			25	ppm/ $^\circ\text{C}$
		B grade, $-40^\circ\text{C} < T_A < +125^\circ\text{C}$			9	ppm/ $^\circ\text{C}$
SUPPLY VOLTAGE HEADROOM	$V_{IN} - V_O$		300			mV
LINE REGULATION	$\Delta V_O / \Delta V_{IN}$	$V_{IN} = 2.8\text{ V to }15\text{ V}$, $-40^\circ\text{C} < T_A < +125^\circ\text{C}$		10	25	ppm/V
LOAD REGULATION	$\Delta V_O / \Delta I_{LOAD}$	$I_{LOAD} = 0\text{ mA to }5\text{ mA}$, $-40^\circ\text{C} < T_A < +85^\circ\text{C}$, $V_{IN} = 3\text{ V}$			60	ppm/mA
		$I_{LOAD} = 0\text{ mA to }5\text{ mA}$, $-40^\circ\text{C} < T_A < +125^\circ\text{C}$, $V_{IN} = 3\text{ V}$			140	ppm/mA
QUIESCENT CURRENT	I_{IN}	No load $-40^\circ\text{C} < T_A < +125^\circ\text{C}$			120	μA
					140	μA
VOLTAGE NOISE	$e_{n\text{ p-p}}$	0.1 Hz to 10 Hz		5		$\mu\text{V p-p}$
TURN-ON SETTLING TIME	t_R			20		μs
LONG-TERM STABILITY ¹	ΔV_O	1000 hours		50		ppm
OUTPUT VOLTAGE HYSTERESIS	ΔV_{O_HYS}			100		ppm
RIPPLE REJECTION RATIO	RRR	$f_{IN} = 60\text{ Hz}$		-80		dB
SHORT CIRCUIT TO GND	I_{SC}	$V_{IN} = 5\text{ V}$		25		mA
		$V_{IN} = 15\text{ V}$		30		mA
SHUTDOWN PIN			2.4		3	μA
					500	nA
					0.8	V
						V

¹ The long-term stability specification is noncumulative. The drift of subsequent 1000 hour periods is significantly lower than in the first 1000 hour period.

ADR391/ADR392/ADR395

ADR392 ELECTRICAL CHARACTERISTICS

$V_{IN} = 4.3 \text{ V to } 15 \text{ V}$, $T_A = 25^\circ\text{C}$, unless otherwise noted.

Table 3.

Parameter	Symbol	Conditions	Min	Typ	Max	Unit
OUTPUT VOLTAGE	V_O	A grade	4.090	4.096	4.102	V
		B grade	4.091	4.096	4.101	V
INITIAL ACCURACY	V_{OERR}	A grade			6	mV
		A grade			0.15	%
		B grade			5	mV
		B grade			0.12	%
TEMPERATURE COEFFICIENT	TCV_O	A grade, $-40^\circ\text{C} < T_A < +125^\circ\text{C}$			25	ppm/ $^\circ\text{C}$
		B grade, $-40^\circ\text{C} < T_A < +125^\circ\text{C}$			9	ppm/ $^\circ\text{C}$
SUPPLY VOLTAGE HEADROOM	$V_{IN} - V_O$		300			mV
LINE REGULATION	$\Delta V_O / \Delta V_{IN}$	$V_{IN} = 4.3 \text{ V to } 15 \text{ V}$, $-40^\circ\text{C} < T_A < +125^\circ\text{C}$		10	25	ppm/V
LOAD REGULATION	$\Delta V_O / \Delta I_{LOAD}$	$I_{LOAD} = 0 \text{ mA to } 5 \text{ mA}$, $-40^\circ\text{C} < T_A < +125^\circ\text{C}$, $V_{IN} = 5 \text{ V}$			140	ppm/mA
QUIESCENT CURRENT	I_{IN}	No load			120	μA
		$-40^\circ\text{C} < T_A < +125^\circ\text{C}$			140	μA
VOLTAGE NOISE	$e_{n \text{ p-p}}$	0.1 Hz to 10 Hz		7		$\mu\text{V p-p}$
TURN-ON SETTLING TIME	t_R			20		μs
LONG-TERM STABILITY ¹	ΔV_O	1000 hours		50		ppm
OUTPUT VOLTAGE HYSTERESIS	ΔV_{O_HYS}			100		ppm
RIPPLE REJECTION RATIO	RRR	$f_{IN} = 60 \text{ Hz}$		-80		dB
SHORT CIRCUIT TO GND	I_{SC}	$V_{IN} = 5 \text{ V}$		25		mA
		$V_{IN} = 15 \text{ V}$		30		mA
SHUTDOWN PIN						
Shutdown Supply Current	I_{SHDN}				3	μA
Shutdown Logic Input Current	I_{LOGIC}				500	nA
Shutdown Logic Low	V_{INL}				0.8	V
Shutdown Logic High	V_{INH}		2.4			V

¹ The long-term stability specification is noncumulative. The drift of subsequent 1000 hour periods is significantly lower than in the first 1000 hour period.

ADR395 ELECTRICAL CHARACTERISTICS

$V_{IN} = 5.3\text{ V to }15\text{ V}$, $T_A = 25^\circ\text{C}$, unless otherwise noted.

Table 4.

Parameter	Symbol	Conditions	Min	Typ	Max	Unit
OUTPUT VOLTAGE	V_O	A grade	4.994	5.000	5.006	V
		B grade	4.995	5.000	5.005	V
INITIAL ACCURACY	V_{OERR}	A grade			6	mV
		A grade			0.12	%
		B grade			5	mV
		B grade			0.10	%
TEMPERATURE COEFFICIENT	TCV_O	A grade, $-40^\circ\text{C} < T_A < +125^\circ\text{C}$			25	ppm/ $^\circ\text{C}$
		B grade, $-40^\circ\text{C} < T_A < +125^\circ\text{C}$			9	ppm/ $^\circ\text{C}$
SUPPLY VOLTAGE HEADROOM	$V_{IN} - V_O$		300			mV
LINE REGULATION	$\Delta V_O / \Delta V_{IN}$	$V_{IN} = 4.3\text{ V to }15\text{ V}$, $-40^\circ\text{C} < T_A < +125^\circ\text{C}$		10	25	ppm/V
LOAD REGULATION	$\Delta V_O / \Delta I_{LOAD}$	$I_{LOAD} = 0\text{ mA to }5\text{ mA}$, $-40^\circ\text{C} < T_A < +125^\circ\text{C}$, $V_{IN} = 6\text{ V}$			140	ppm/mA
QUIESCENT CURRENT	I_{IN}	No load			120	μA
		$-40^\circ\text{C} < T_A < +125^\circ\text{C}$			140	μA
VOLTAGE NOISE	$e_{n\text{ p-p}}$	0.1 Hz to 10 Hz		8		$\mu\text{V p-p}$
TURN-ON SETTLING TIME	t_R			20		μs
LONG-TERM STABILITY ¹	ΔV_O	1000 hours		50		ppm
OUTPUT VOLTAGE HYSTERESIS	ΔV_{O_HYS}			100		ppm
RIPPLE REJECTION RATIO	RRR	$f_{IN} = 60\text{ Hz}$		-80		dB
SHORT CIRCUIT TO GND	I_{SC}	$V_{IN} = 5\text{ V}$		25		mA
		$V_{IN} = 15\text{ V}$		30		mA
SHUTDOWN PIN						
Shutdown Supply Current	I_{SHDN}				3	μA
Shutdown Logic Input Current	I_{LOGIC}				500	nA
Shutdown Logic Low	V_{INL}				0.8	V
Shutdown Logic High	V_{INH}		2.4			V

¹ The long-term stability specification is noncumulative. The drift of subsequent 1000 hour periods is significantly lower than in the first 1000 hour period.

ADR391/ADR392/ADR395

ABSOLUTE MAXIMUM RATINGS

At 25°C, unless otherwise noted.

Table 5.

Parameter	Rating
Supply Voltage	18 V
Output Short-Circuit Duration to GND	See derating curves
Storage Temperature Range	–65°C to +125°C
Operating Temperature Range	–40°C to +125°C
Junction Temperature Range	–65°C to +125°C
Lead Temperature (Soldering, 60 sec)	300°C

Stresses above those listed under Absolute Maximum Ratings may cause permanent damage to the device. This is a stress rating only; functional operation of the device at these or any other conditions above those indicated in the operational section of this specification is not implied. Exposure to absolute maximum rating conditions for extended periods may affect device reliability.

THERMAL RESISTANCE

θ_{JA} is specified for the worst-case conditions, that is, for a device soldered in a circuit board for surface-mount packages.

Table 6.

Package Type	θ_{JA}	θ_{JC}	Unit
TSOT (UJ-5)	230	146	°C/W

ESD CAUTION



ESD (electrostatic discharge) sensitive device. Charged devices and circuit boards can discharge without detection. Although this product features patented or proprietary protection circuitry, damage may occur on devices subjected to high energy ESD. Therefore, proper ESD precautions should be taken to avoid performance degradation or loss of functionality.

TYPICAL PERFORMANCE CHARACTERISTICS

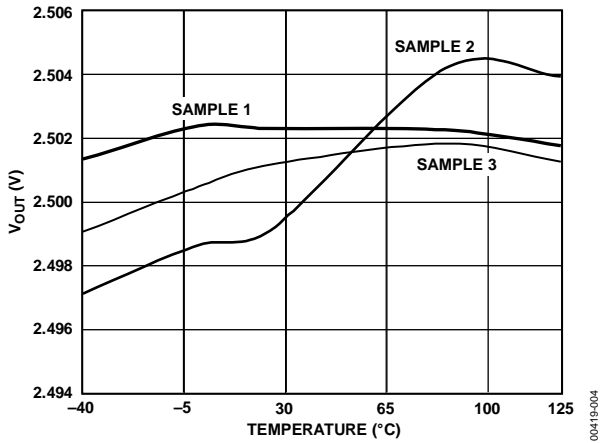

Figure 2. ADR391 Output Voltage (V_{OUT}) vs. Temperature

00419-004

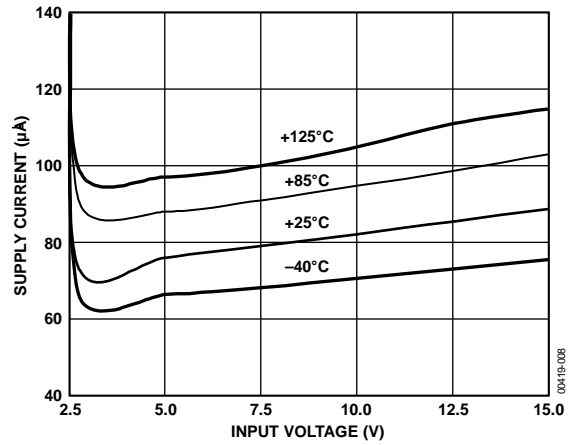

Figure 5. ADR391 Supply Current vs. Input Voltage

00419-008

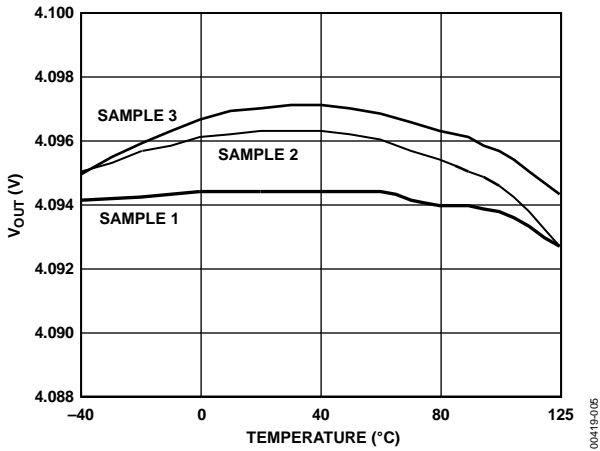

Figure 3. ADR392 Output Voltage (V_{OUT}) vs. Temperature

00419-005

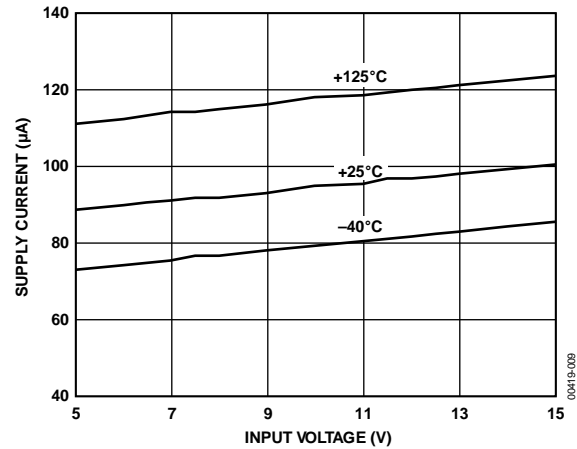

Figure 6. ADR392 Supply Current vs. Input Voltage

00419-009

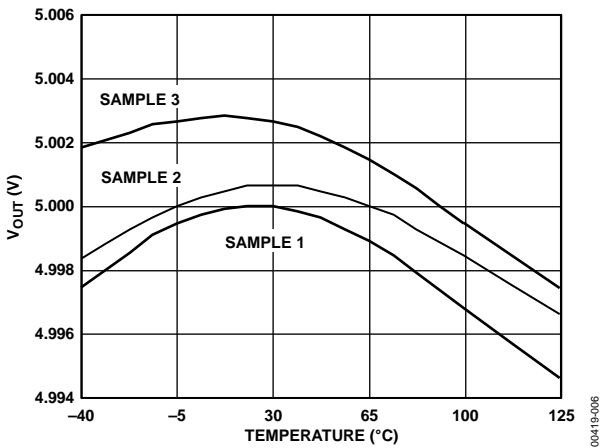

Figure 4. ADR395 Output Voltage (V_{OUT}) vs. Temperature

00419-006

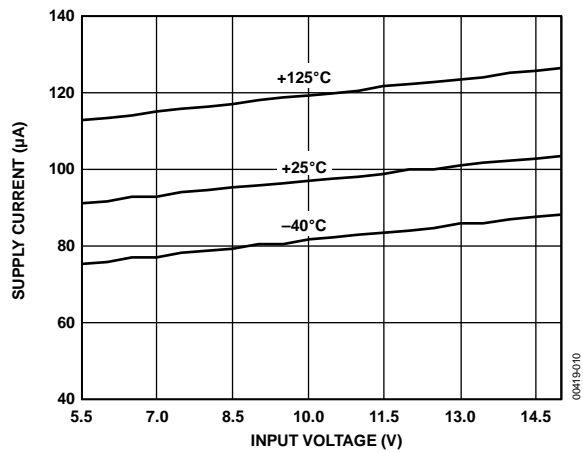

Figure 7. ADR395 Supply Current vs. Input Voltage

00419-010

ADR391/ADR392/ADR395

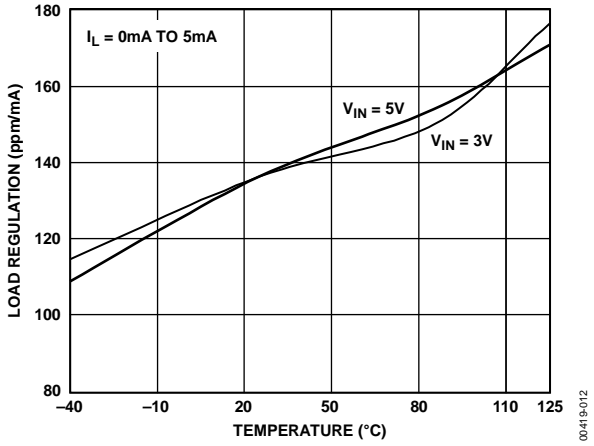

Figure 8. ADR391 Load Regulation vs. Temperature

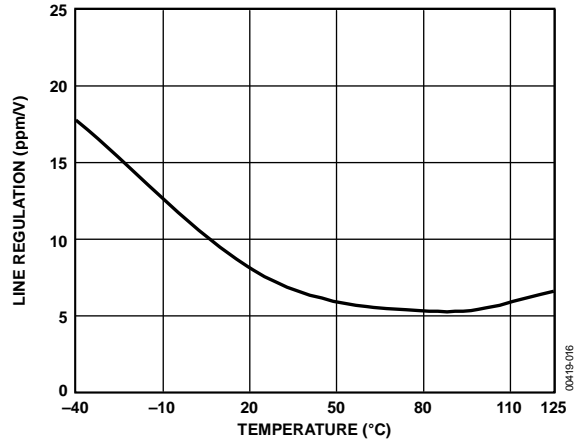

Figure 11. ADR391 Line Regulation vs. Temperature

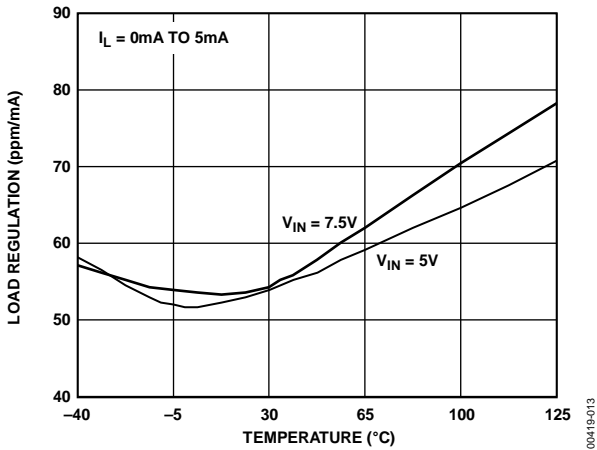

Figure 9. ADR392 Load Regulation vs. Temperature

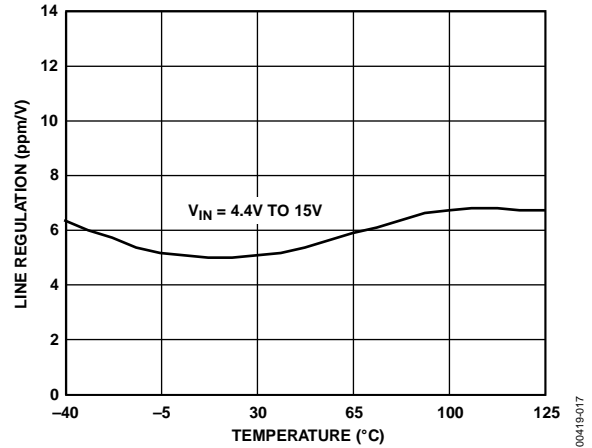

Figure 12. ADR392 Line Regulation vs. Temperature

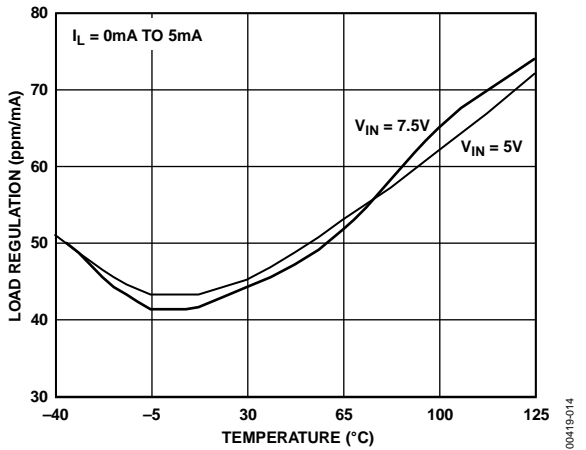

Figure 10. ADR395 Load Regulation vs. Temperature

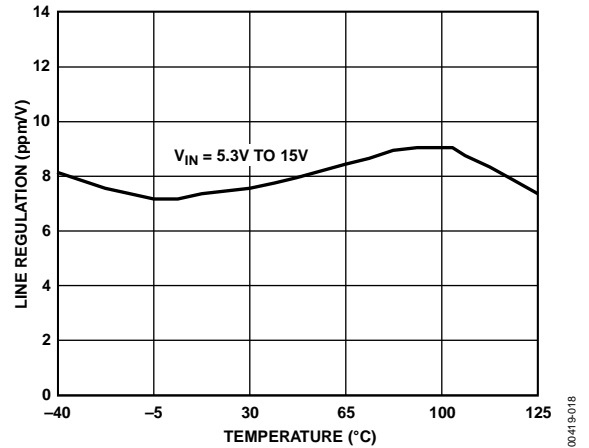

Figure 13. ADR395 Line Regulation vs. Temperature

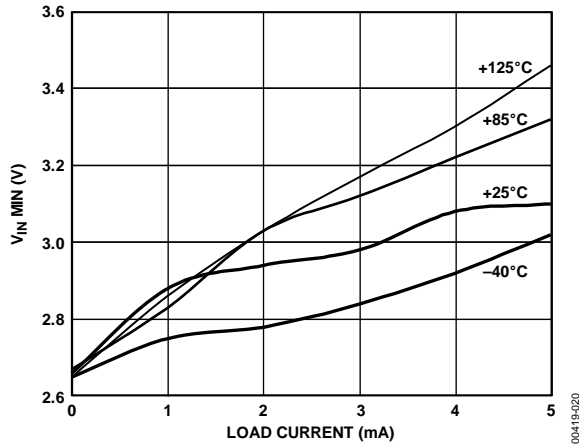

Figure 14. ADR391 Minimum Input Voltage (V_{IN}) vs. Load Current

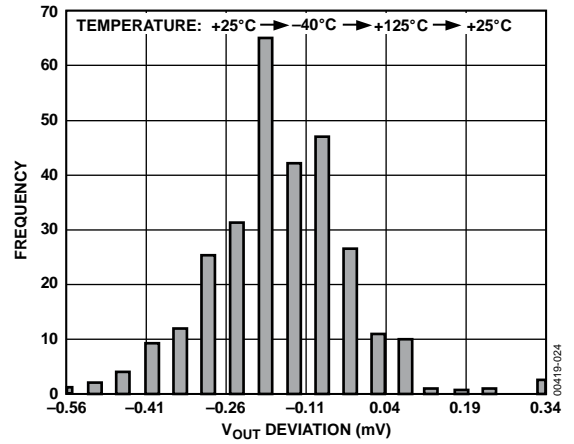

Figure 17. ADR391 V_{OUT} Hysteresis Distribution

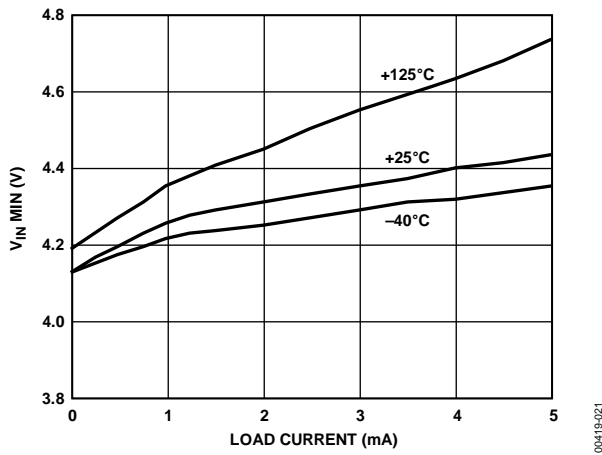

Figure 15. ADR392 Minimum Input Voltage (V_{IN}) vs. Load Current

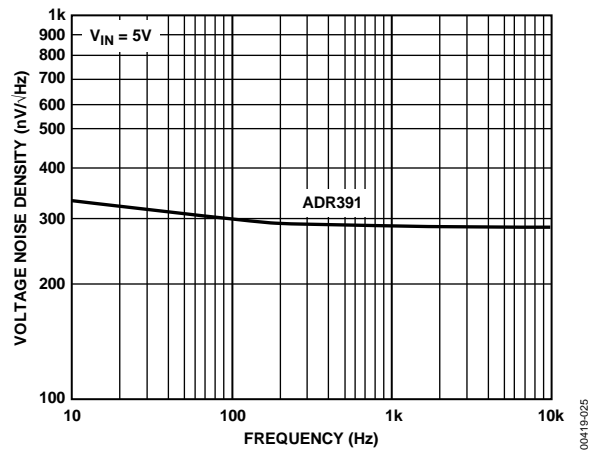

Figure 18. Voltage Noise Density vs. Frequency

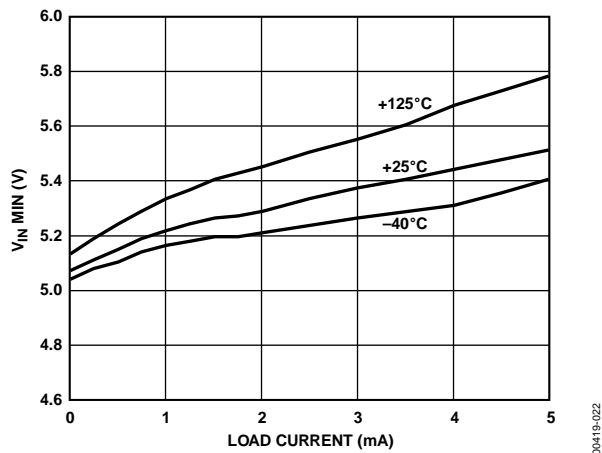

Figure 16. ADR395 Minimum Input Voltage (V_{IN}) vs. Load Current

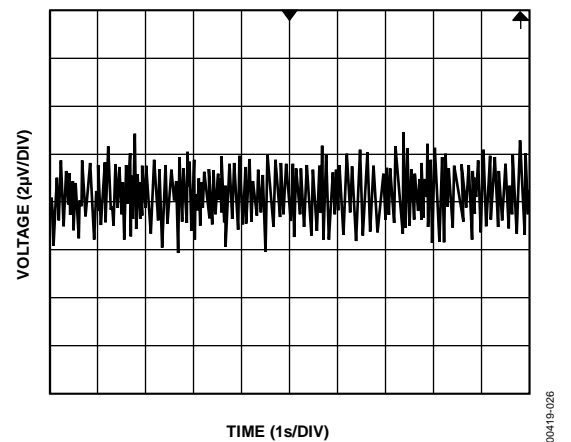

Figure 19. ADR391 Typical Voltage Noise 0.1 Hz to 10 Hz

ADR391/ADR392/ADR395

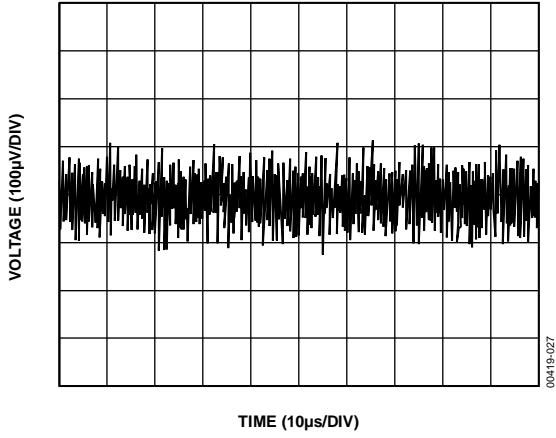

Figure 20. ADR391 Voltage Noise 10 Hz to 10 kHz

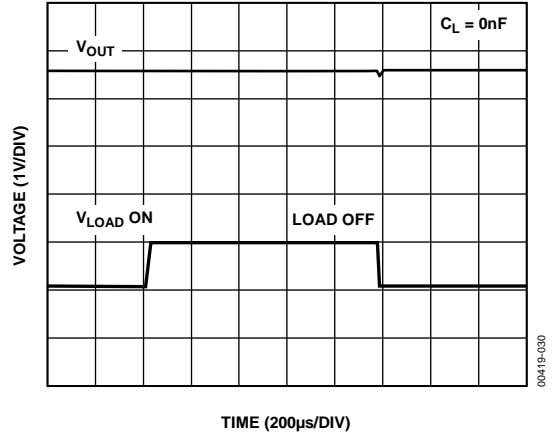

Figure 23. ADR391 Load Transient Response

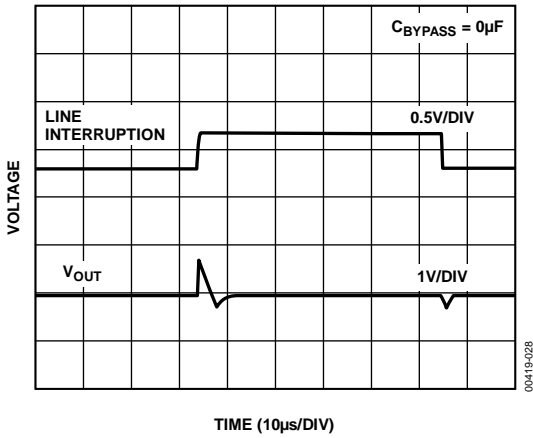

Figure 21. ADR391 Line Transient Response

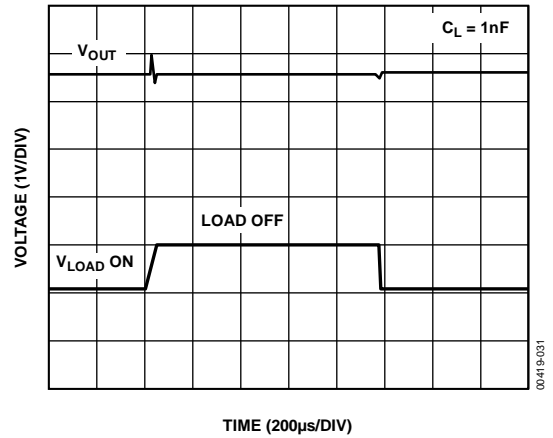

Figure 24. ADR391 Load Transient Response

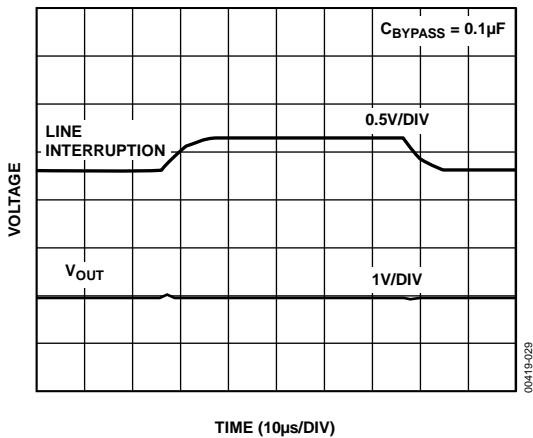

Figure 22. ADR391 Line Transient Response

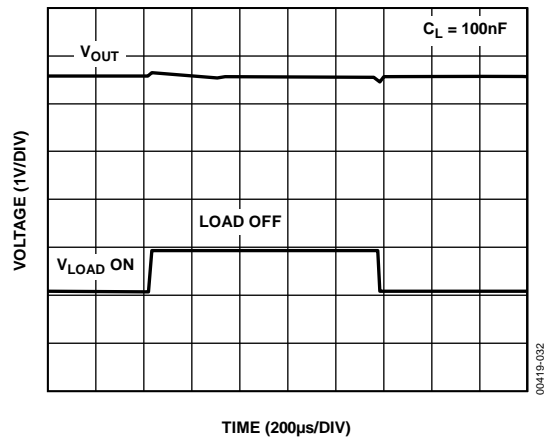

Figure 25. ADR391 Load Transient Response

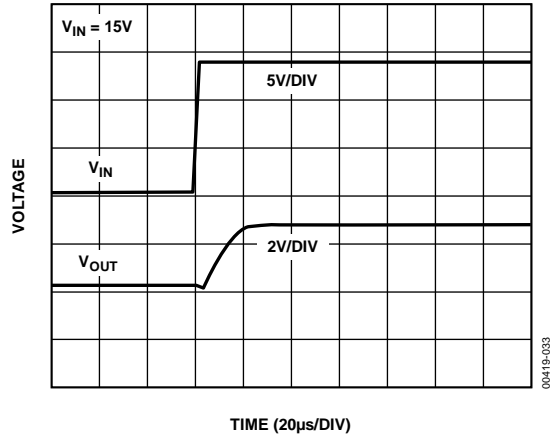

Figure 26. ADR391 Turn-On Response Time at 15 V

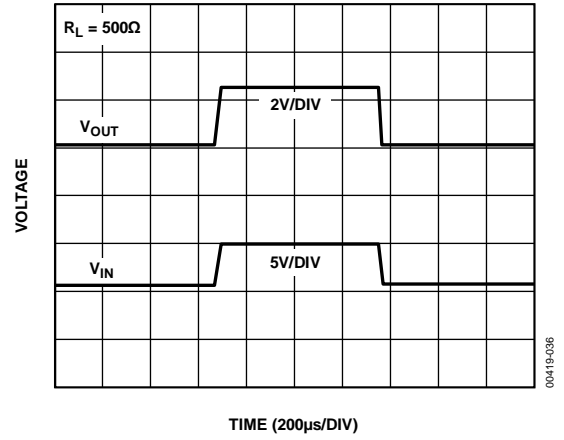

Figure 29. ADR391 Turn-On/Turn-Off Response at 5 V with Resistor Load

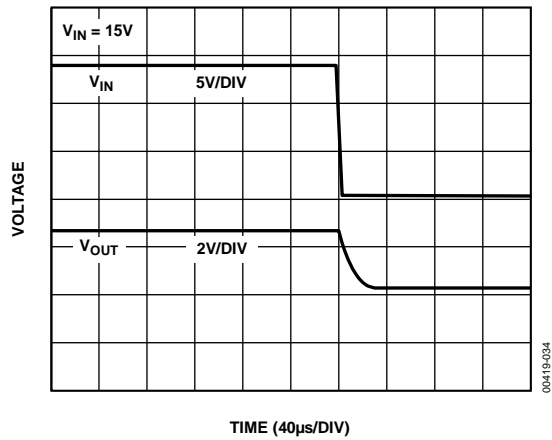

Figure 27. ADR391 Turn-Off Response at 15 V

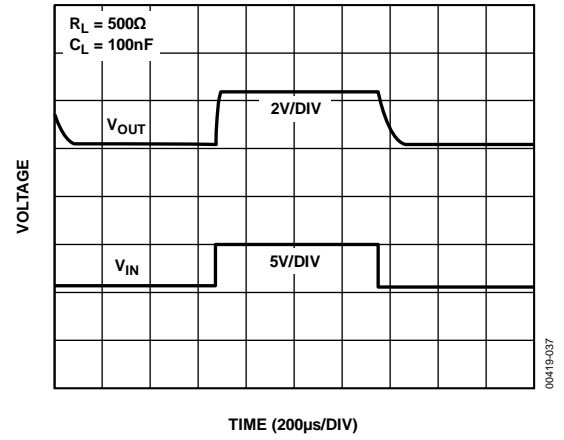

Figure 30. ADR391 Turn-On/Turn-Off Response at 5 V

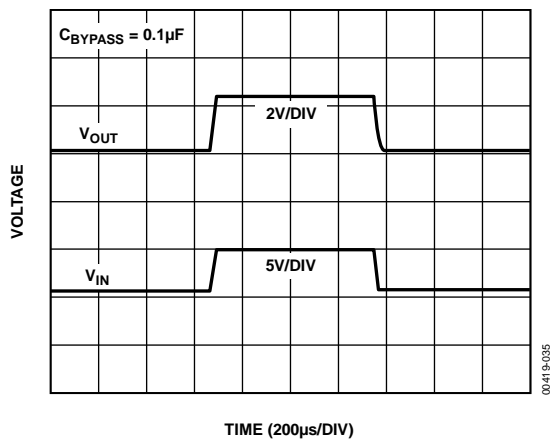

Figure 28. ADR391 Turn-On/Turn-Off Response at 5 V with Capacitance

ADR391/ADR392/ADR395

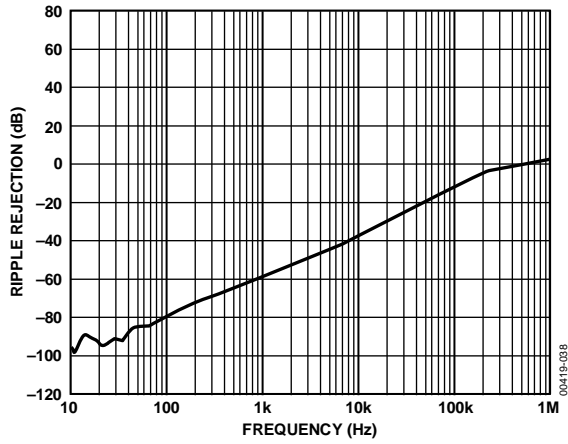

Figure 31. Ripple Rejection vs. Frequency

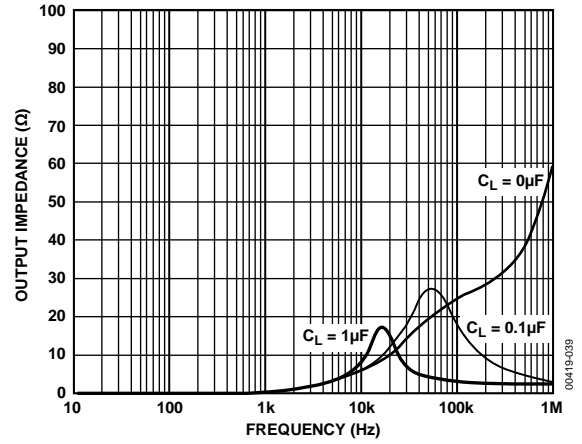

Figure 32. Output Impedance vs. Frequency

TERMINOLOGY

Temperature Coefficient

The change of output voltage with respect to operating temperature changes normalized by the output voltage at 25°C. This parameter is expressed in ppm/°C and can be determined by

$$TCV_o[\text{ppm}/^\circ\text{C}] = \frac{V_o(T_2) - V_o(T_1)}{V_o(25^\circ\text{C}) \times (T_2 - T_1)} \times 10^6 \quad (1)$$

where:

$V_o(25^\circ\text{C})$ is V_o at 25°C.

$V_o(T_1)$ is V_o at Temperature 1.

$V_o(T_2)$ is V_o at Temperature 2.

Line Regulation

The change in output voltage due to a specified change in input voltage. This parameter accounts for the effects of self-heating. Line regulation is expressed in either percent per volt, parts-per-million per volt, or microvolts per volt change in input voltage.

Load Regulation

The change in output voltage due to a specified change in load current. This parameter accounts for the effects of self-heating. Load regulation is expressed in either microvolts per milliampere, parts-per-million per milliampere, or ohms of dc output resistance.

Long-Term Stability

Typical shift of output voltage at 25°C on a sample of parts subjected to a test of 1000 hours at 25°C.

$$\Delta V_o = V_o(t_0) - V_o(t_1)$$

$$\Delta V_o[\text{ppm}] = \left(\frac{V_o(t_0) - V_o(t_1)}{V_o(t_0)} \times 10^6 \right) \quad (2)$$

where:

$V_o(t_0)$ is V_o at 25°C at Time 0.

$V_o(t_1)$ is V_o at 25°C after 1000 hours operation at 25°C.

Thermally Induced Output Voltage Hysteresis

The change of output voltage after the device cycles through the temperatures from +25°C to -40°C to +125°C and back to +25°C. This is a typical value from a sample of parts put through such a cycle.

$$V_{o_HYS} = V_o(25^\circ\text{C}) - V_{o_TC} \quad (3)$$

$$V_{o_HYS}[\text{ppm}] = \frac{V_o(25^\circ\text{C}) - V_{o_TC}}{V_o(25^\circ\text{C})} \times 10^6 \quad (4)$$

where:

$V_o(25^\circ\text{C})$ is V_o at 25°C.

V_{o_TC} is V_o at 25°C after a temperature cycle from +25°C to -40°C to +125°C and back to +25°C.

APPLICATIONS INFORMATION

BASIC VOLTAGE REFERENCE CONNECTION

The circuit shown in Figure 34 illustrates the basic configuration for the ADR39x family. Decoupling capacitors are not required for circuit stability. The ADR39x family is capable of driving capacitive loads from 0 μ F to 10 μ F. However, a 0.1 μ F ceramic output capacitor is recommended to absorb and deliver the charge, as required by a dynamic load.

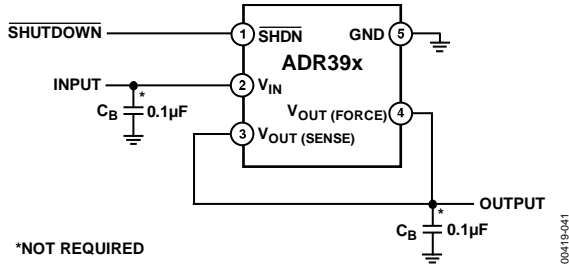

Figure 34. Basic Configuration for the ADR39x Family

Stacking Reference ICs for Arbitrary Outputs

Some applications may require two reference voltage sources, which are a combined sum of standard outputs. Figure 35 shows how this stacked output reference can be implemented.

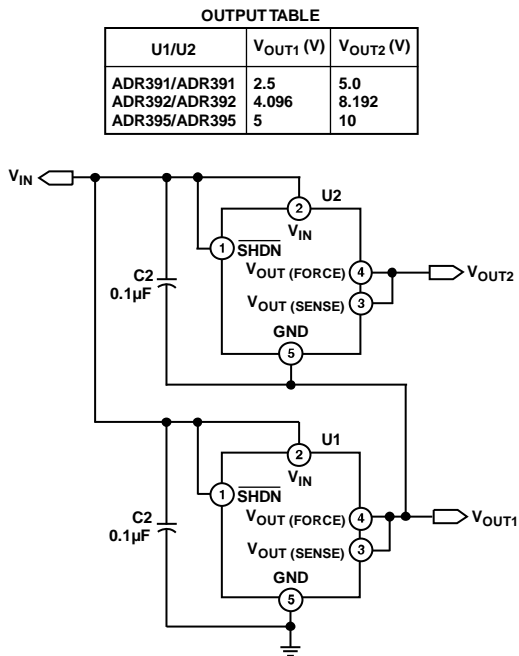

Figure 35. Stacking Voltage References with the ADR391/ADR392/ADR395

Two reference ICs are used, fed from an unregulated input, V_{IN} . The outputs of the individual ICs are connected in series, which provide two output voltages, V_{OUT1} and V_{OUT2} . V_{OUT1} is the terminal voltage of U1, while V_{OUT2} is the sum of this voltage and the terminal voltage of U2. U1 and U2 are chosen for the two voltages that supply the required outputs (see the Output Table in Figure 35). For example, if both U1 and U2 are ADR391s, V_{OUT1} is 2.5 V and V_{OUT2} is 5.0 V.

While this concept is simple, a precaution is required. Because the lower reference circuit must sink a small bias current from U2 plus the base current from the series PNP output transistor in U2, either the external load of U1 or an external resistor must provide a path for this current. If the U1 minimum load is not well defined, the external resistor should be used and set to a value that conservatively passes 600 μ A of current with the applicable V_{OUT1} across it. Note that the two U1 and U2 reference circuits are treated locally as macrocells; each has its own bypasses at input and output for best stability. Both U1 and U2 in this circuit can source dc currents up to their full rating. The minimum input voltage, V_{IN} , is determined by the sum of the outputs, V_{OUT2} , plus the dropout voltage of U2.

A Negative Precision Reference without Precision Resistors

A negative reference can be easily generated by adding an A1 op amp and is configured as shown in Figure 36. $V_{OUT (FORCE)}$ and $V_{OUT (SENSE)}$ are at virtual ground and, therefore, the negative reference can be taken directly from the output of the op amp. The op amp must be dual-supply, low offset, and rail-to-rail if the negative supply voltage is close to the reference output.

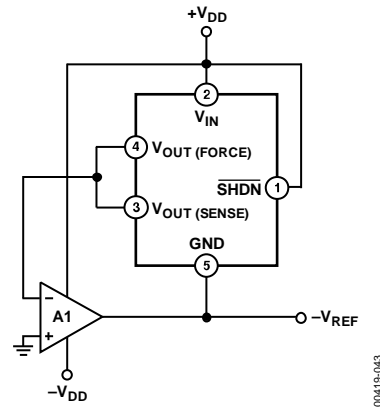

Figure 36. Negative Reference

ADR391/ADR392/ADR395

General-Purpose Current Source

Many times in low power applications, the need arises for a precision current source that can operate on low supply voltages. The ADR391/ADR392/ADR395 can be configured as a precision current source. As shown in Figure 37, the circuit configuration is a floating current source with a grounded load. The reference output voltage is bootstrapped across R_{SET} , which sets the output current into the load. With this configuration, circuit precision is maintained for load currents in the range from the reference supply current, typically 90 μA to approximately 5 mA.

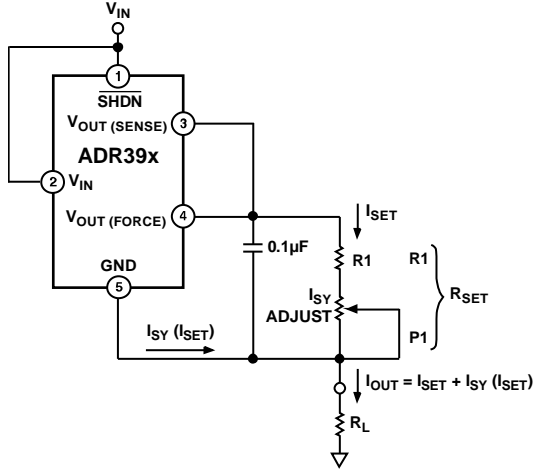

Figure 37. A General-Purpose Current Source

00419-044

High Power Performance with Current Limit

In some cases, the user may want higher output current delivered to a load and still achieve better than 0.5% accuracy out of the ADR39x. The accuracy for a reference is normally specified on the data sheet with no load. However, the output voltage changes with load current.

The circuit shown in Figure 38 provides high current without compromising the accuracy of the ADR39x. The series pass transistor, Q1, provides up to 1 A load current. The ADR39x delivers only the base drive to Q1 through the force pin. The sense pin of the ADR39x is a regulated output and is connected to the load.

The Transistor Q2 protects Q1 during short-circuit limit faults by robbing its base drive. The maximum current is

$$I_{LMAX} \approx 0.6 \text{ V}/R_s \quad (6)$$

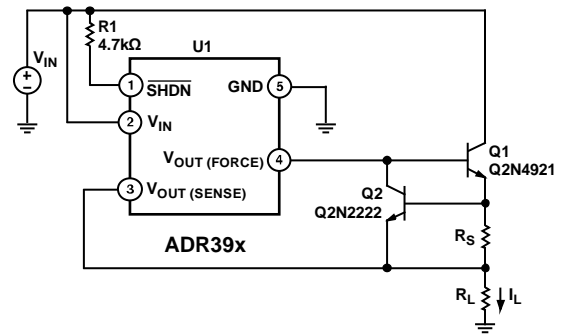

Figure 38. ADR39x for High Power Performance with Current Limit

00419-045

A similar circuit function can also be achieved with the Darlington transistor configuration, as shown in Figure 39.

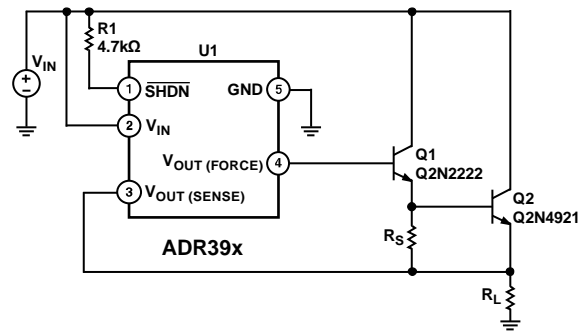

Figure 39. ADR39x for High Output Current with Darlington Drive Configuration

00419-D-046

CAPACITORS

Input Capacitor

Input capacitors are not required on the ADR39x. There is no limit for the value of the capacitor used on the input, but a 1 μF to 10 μF capacitor on the input improves transient response in applications where the supply suddenly changes. An additional 0.1 μF in parallel also helps reduce noise from the supply.

Output Capacitor

The ADR39x does not require output capacitors for stability under any load condition. An output capacitor, typically 0.1 μF , filters out any low level noise voltage and does not affect the operation of the part. On the other hand, the load transient response can improve with the addition of a 1 μF to 10 μF output capacitor in parallel. A capacitor here acts as a source of stored energy for a sudden increase in load current. The only parameter that degrades by adding an output capacitor is the turn-on time, and it depends on the size of the capacitor chosen.

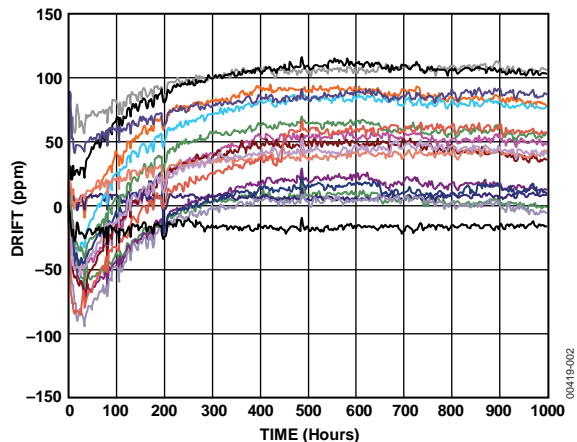
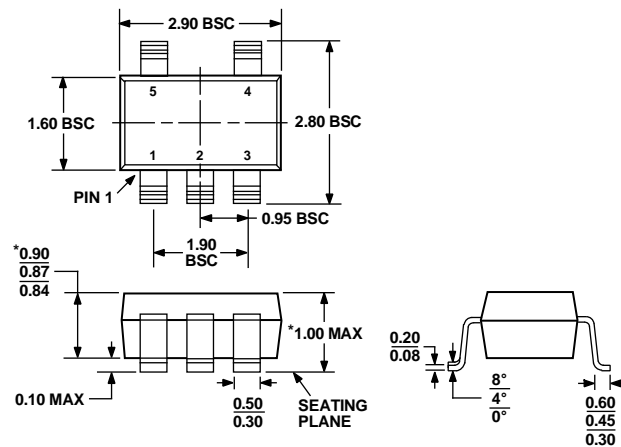

Figure 40. ADR391 Typical Long-Term Drift over 1000 Hours

ADR391/ADR392/ADR395

OUTLINE DIMENSIONS



*COMPLIANT TO JEDEC STANDARDS MO-193-AB WITH THE EXCEPTION OF PACKAGE HEIGHT AND THICKNESS.

Figure 41. 5-Lead Thin Small Outline Transistor Package [TSOT] (UJ-5)

Dimensions shown in millimeters

ORDERING GUIDE

Model	Output Voltage (V _o)	Initial Accuracy		Temperature Coefficient (ppm/°C)	Package Description	Package Option	Branding	Ordering Quantity	Temperature Range
		(mV)	(%)						
ADR391AUJZ-REEL ¹	2.5	±6	0.24	25	5-Lead TSOT	UJ-5	R1A	3,000	-40°C to +125°C
ADR391AUJZ-R2 ¹	2.5	±6	0.24	25	5-Lead TSOT	UJ-5	R1A	250	-40°C to +125°C
ADR391BUJZ-REEL ¹	2.5	±4	0.16	9	5-Lead TSOT	UJ-5	R1B	3,000	-40°C to +125°C
ADR391BUJZ-R2 ¹	2.5	±4	0.16	9	5-Lead TSOT	UJ-5	R1B	250	-40°C to +125°C
ADR392AUJZ-REEL ¹	4.096	±6	0.15	25	5-Lead TSOT	UJ-5	RCA	3,000	-40°C to +125°C
ADR392AUJZ-R2 ¹	4.096	±6	0.15	25	5-Lead TSOT	UJ-5	RCA	250	-40°C to +125°C
ADR392BUJZ-REEL ¹	4.096	±5	0.12	9	5-Lead TSOT	UJ-5	RCB	3,000	-40°C to +125°C
ADR392BUJZ-R2 ¹	4.096	±5	0.12	9	5-Lead TSOT	UJ-5	RCB	250	-40°C to +125°C
ADR392WBUJZ-R7 ^{1, 2}	4.096	±5	0.12	9	5-Lead TSOT	UJ-5	RCB	3,000	-40°C to +125°C
ADR395AUJZ-REEL ¹	5.0	±6	0.12	25	5-Lead TSOT	UJ-5	RDA	3,000	-40°C to +125°C
ADR395AUJZ-R2 ¹	5.0	±6	0.12	25	5-Lead TSOT	UJ-5	RDA	250	-40°C to +125°C
ADR395BUJZ-REEL ¹	5.0	±5	0.10	9	5-Lead TSOT	UJ-5	RDB	3,000	-40°C to +125°C
ADR395BUJZ-R2 ¹	5.0	±5	0.10	9	5-Lead TSOT	UJ-5	RDB	250	-40°C to +125°C

¹ Z = RoHS Compliant Part.

² Automotive grade.

NOTES

NOTES

Компания «Life Electronics» занимается поставками электронных компонентов импортного и отечественного производства от производителей и со складов крупных дистрибьюторов Европы, Америки и Азии.

С конца 2013 года компания активно расширяет линейку поставок компонентов по направлению коаксиальный кабель, кварцевые генераторы и конденсаторы (керамические, пленочные, электролитические), за счёт заключения дистрибьюторских договоров

Мы предлагаем:

- Конкуренеспособные цены и скидки постоянным клиентам.
- Специальные условия для постоянных клиентов.
- Подбор аналогов.
- Поставку компонентов в любых объемах, удовлетворяющих вашим потребностям.
- Приемлемые сроки поставки, возможна ускоренная поставка.
- Доставку товара в любую точку России и стран СНГ.
- Комплексную поставку.
- Работу по проектам и поставку образцов.
- Формирование склада под заказчика.
- Сертификаты соответствия на поставляемую продукцию (по желанию клиента).
- Тестирование поставляемой продукции.
- Поставку компонентов, требующих военную и космическую приемку.
- Входной контроль качества.
- Наличие сертификата ISO.

В составе нашей компании организован Конструкторский отдел, призванный помогать разработчикам, и инженерам.

Конструкторский отдел помогает осуществить:

- Регистрацию проекта у производителя компонентов.
- Техническую поддержку проекта.
- Защиту от снятия компонента с производства.
- Оценку стоимости проекта по компонентам.
- Изготовление тестовой платы монтаж и пусконаладочные работы.



Тел: +7 (812) 336 43 04 (многоканальный)
Email: org@lifeelectronics.ru