

Fiber Optic Receiver

OPF2418, OPF2418T



Features:

- Up to 194 Mbps operation
- 850nm wavelength
- ST[®] style port
- Wave solderable
- Wide temperature range

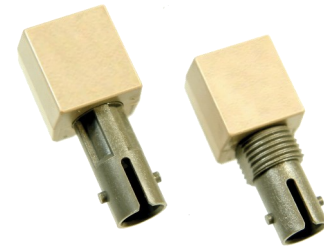

Description:

The OPF2418 family is a low cost solution for high speed fiber optic communications designs. The internal lensing of this receiver’s design allows optimal response for fiber sizes of 100µm and below. The receiver is comprised of a high speed, low noise, photodiode coupled to a transimpedance amplifier (TIA). The photodiode/TIA combination produces an output voltage that is proportional to the input light amplitude. This hybrid approach solves many of the problems of high speed data link designs by placing the photodiode close to the TIA. The amplification of the TIA makes the output much less susceptible to EMI. The output of the OPF2418 is an analog, low impedance, emitter follower voltage source. Subsequent circuitry can be utilized to convert the analog voltage to ECL/TTL for digital data rates up to 155 Mbps. The OPF2418 is available with either standard or threaded panel mount ST⁰ receptacles. The threaded version is also available in conductive plastic.

Applications:

- Industrial Ethernet equipment
- Copper-to-fiber media conversion
- Intra-system fiber optic links
- Video surveillance systems

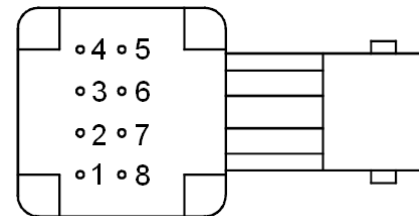
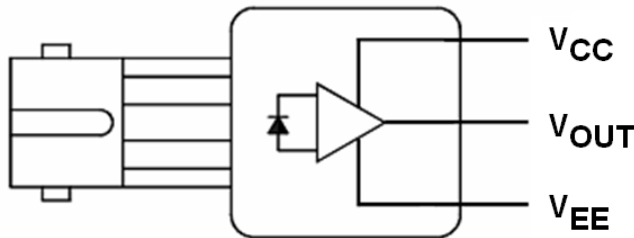

PIN	FUNCTION
1	Not Connected
2	V _{OUT}
3	V _{EE}
4	Not Connected
5	Not Connected
6	V _{CC}
7	V _{EE}
8	Not Connected

“T” suffix = Threaded ST[®] package
 \

Pins 3 & 7 are electrically connected to the header.
 Pins 1,4,5 & 8 are mechanically connected together.



RoHS



ESD Class 2

ST[®] is a registered trademark of AT&T.

General Note

TT Electronics reserves the right to make changes in product specification without notice or liability. All information is subject to TT Electronics’ own data and is considered accurate at time of going to print.

TT Electronics | OPTEK Technology, Inc.
 1645 Wallace Drive, Carrollton, TX 75006 | Ph: +1 972 323 2200
 sensors@ttelelectronics.com | www.ttelelectronics.com

Fiber Optic Receiver

OPF2418, OPF2418T



Mechanical Data

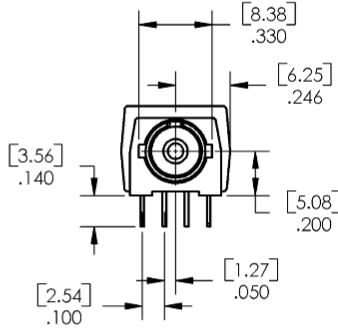
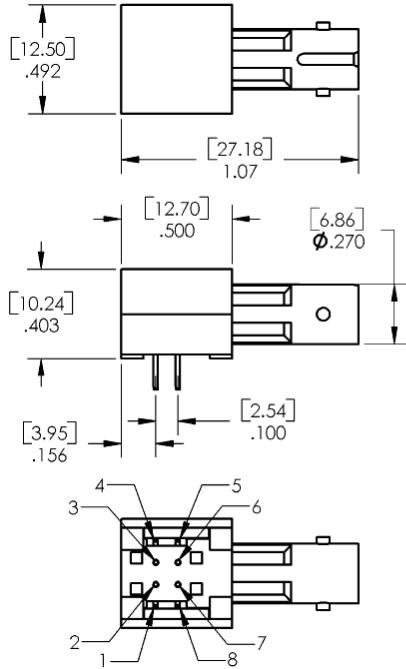

PINS 1, 4, 5, & 8 - .020 X .015
[0.51 X 0.38]
PINS 2, 3, 6, & 7 - Ø.018
[0.46]

OPF2418

OPF2418T

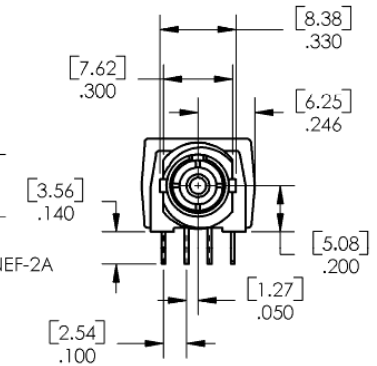
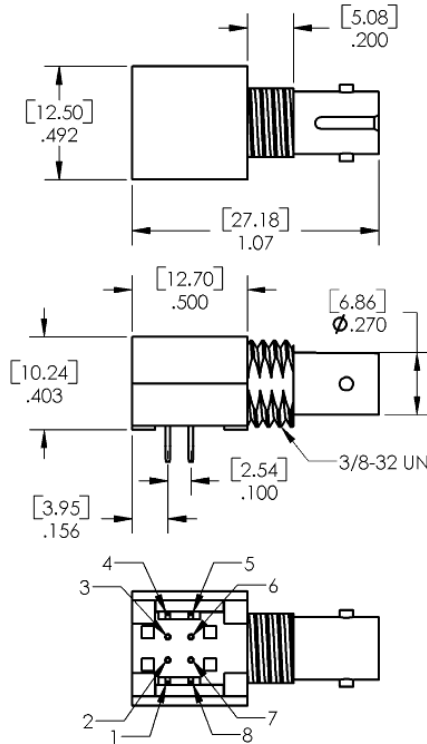

PINS 1, 4, 5, & 8 - .020 X .015
[0.51 X 0.38]
PINS 2, 3, 6, & 7 - Ø.018
[0.46]

DIMENSIONS ARE IN: [MILLIMETERS]
INCHES

General Note

TT Electronics reserves the right to make changes in product specification without notice or liability. All information is subject to TT Electronics' own data and is considered accurate at time of going to print.

TT Electronics | OPTEK Technology, Inc.
1645 Wallace Drive, Carrollton, TX 75006 | Ph: +1 972 323 2200
sensors@ttelelectronics.com | www.ttelelectronics.com

Fiber Optic Receiver

OPF2418, OPF2418T



Electrical Specifications

Absolute Maximum Ratings ($T_A = 25^\circ\text{C}$ unless otherwise noted)	
Storage Temperature Range	-55° C to +85° C
Operating Temperature Range	-40° C to +85° C
Lead Soldering Temperature ⁽¹⁾	260° C
Supply Voltage	-0.5 V to 6.0 V
Output Current	25 mA
Output Pin Voltage	-0.5 V

Electrical Characteristics ($T_A = 25^\circ\text{C}$ unless otherwise noted)						
SYMBOL	PARAMETER	MIN	TYP	MAX	UNITS	TEST CONDITIONS
R	Responsivity	5.3	7.0	9.6	mV/ μW	$\lambda_p = 850\text{ nm}$, $f = 50\text{ MHz}$
		4.5		11.5		$-40^\circ\text{C} \leq T_A \leq +85^\circ\text{C}$
V_{NOISE}	RMS Output Noise Voltage		0.40	0.59	mV	75 MHz Bandwidth Filtered, $P_R = 0$
				0.70		Unfiltered Bandwidth Filtered, $P_R = 0$
P_N	RMS Equivalent Optical Noise Input Power		0.050	0.065	μW	100 MHz Bandwidth Filtered, $P_R = 0$
P_R	Peak Received Optical Power			175	μW	$40^\circ\text{C} \leq T_A \leq +85^\circ\text{C}$
				150		
V_{ODC}	DC Output Voltage	-4.2	-3.1	-2.4	V	$P_R = 0$
I_{EE}	Supply Current		9	15	mA	$R_L = \infty$
BW	Bandwidth	155	200		MHz	-3dB electrical
t_r, t_f	Rise Time, Fall Time		2.0	2.6	ns	$f = 50\text{ MHz}$, $P_R = 100\ \mu\text{W peak}$, $R_L = 511\ \Omega$, $C_{\text{LOAD}} = 5\text{ pF}$
PWD	Pulse Width Distortion		0.4	2.5	ns	$f = 50\text{ MHz}$, $P_R = 150\ \mu\text{W peak}$
PSRR	Power Supply Rejection Ratio		20		dB	$f = 10\text{ MHz}$

Notes:

- Maximum of 5 seconds with soldering iron. Duration can be extended to 10 seconds when flow soldering. RMA flux is recommended.

Application Circuit

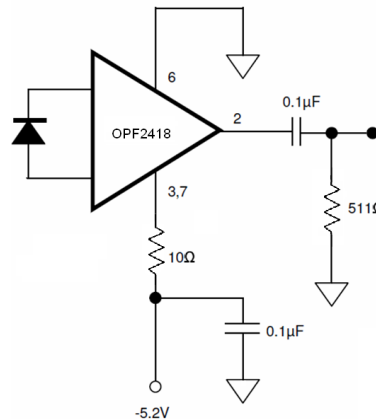

Note that the 10Ω resistor and bypass capacitor are critical.

General Note

TT Electronics reserves the right to make changes in product specification without notice or liability. All information is subject to TT Electronics' own data and is considered accurate at time of going to print.

TT Electronics | OPTeK Technology, Inc.
1645 Wallace Drive, Carrollton, TX 75006 | Ph: +1 972 323 2200
sensors@ttelelectronics.com | www.ttelelectronics.com

Компания «Life Electronics» занимается поставками электронных компонентов импортного и отечественного производства от производителей и со складов крупных дистрибьюторов Европы, Америки и Азии.

С конца 2013 года компания активно расширяет линейку поставок компонентов по направлению коаксиальный кабель, кварцевые генераторы и конденсаторы (керамические, пленочные, электролитические), за счёт заключения дистрибьюторских договоров

Мы предлагаем:

- Конкуренспособные цены и скидки постоянным клиентам.
- Специальные условия для постоянных клиентов.
- Подбор аналогов.
- Поставку компонентов в любых объемах, удовлетворяющих вашим потребностям.
- Приемлемые сроки поставки, возможна ускоренная поставка.
- Доставку товара в любую точку России и стран СНГ.
- Комплексную поставку.
- Работу по проектам и поставку образцов.
- Формирование склада под заказчика.
- Сертификаты соответствия на поставляемую продукцию (по желанию клиента).
- Тестирование поставляемой продукции.
- Поставку компонентов, требующих военную и космическую приемку.
- Входной контроль качества.
- Наличие сертификата ISO.

В составе нашей компании организован Конструкторский отдел, призванный помогать разработчикам, и инженерам.

Конструкторский отдел помогает осуществить:

- Регистрацию проекта у производителя компонентов.
- Техническую поддержку проекта.
- Защиту от снятия компонента с производства.
- Оценку стоимости проекта по компонентам.
- Изготовление тестовой платы монтаж и пусконаладочные работы.



Тел: +7 (812) 336 43 04 (многоканальный)

Email: org@lifeelectronics.ru