

NOTES: UNLESS OTHERWISE SPECIFIED

1. CORNERS DRAWN SHARP TO BE R.005 MAXIMUM.
2. EXTERIOR SURFACE TEXTURE TO BE LIGHT EDM FINISH. EQUIVELANT TO MT-11020.
3. INTERIOR SURFACE TEXTURE TO BE: NONE.
4. ALL INSIDE RADII .010R. ALL OUTSIDE RADII .020R MAX, UNLESS OTHERWISE SPECIFIED.
5. ALL EXTERNAL DIMENSIONS AFFECTED BY THE DRAFT APPLY AT THE LARGE END OF THE FEATURE, AND ALL INTERNAL FEATURES AFFECTED BY THE DRAFT APPLY AT THE SMALL END OF THE FEATURE UNLESS OTHERWISE SPECIFIED.
6. 1 DEGREE DRAFT IN THE DIRECTION OF PULL IS PERMISSIBLE UNLESS OTHERWISE SPECIFIED.
7. ASSEMBLY SCREWS FOR THE ENCLOSURE INCLUDED. MOUNTING SCREWS FOR THE PCB ARE SOLD SEPERATELY.
8. MATERIAL / COLOR: ABS PLASTIC IS STANDARD IN BLACK OR WHITE. CUSTOM MATERIALS AND COLORS ARE AVAILABLE UPON REQUEST FOR QUOTE.
9. PCB SIZES ARE RECOMMENDATIONS ONLY. FINAL SIZES AND VERIFICATION OF ITS FIT ARE THE SOLE RESPONSIBILITY OF THE CUSTOMER.
10. STANDARD OR CUSTOM LABEL RECESSES ARE AVAILABLE UPON REQUEST FOR QUOTE.

434313 ENCLOSURE SHOWN WITH 2 PCB SIZE OPTIONS. THIS ENCLOSURE DOES NOT SUPPORT TWO PCB BOARDS AT ONCE.

R E V I S I O N					
REV.	DRAWN BY	ECO No	DESCRIPTION	DATE	APPROVED
A-J	M BOYER		DEVELOPMENT	2009-Aug-24	D.C.
1.0	M BOYER	N/A	UPDATE TO AS-BUILT AND RELEASE	2010-Mar-29	D.C.
1.1	M BOYER	04515	REVISE ASSEMBLY SCREW LENGTH	2015-Sep-14	D.C.
2.0	R CRUZ	03018	REMOVE-FP, INCLUDE FACEPLATE WITH -F(x) OPTIONS	2018-Oct-31	D.C.
2.1	M BOYER	00219	CLARIFY FACEPLATE DETAILS	2019-Jan-28	

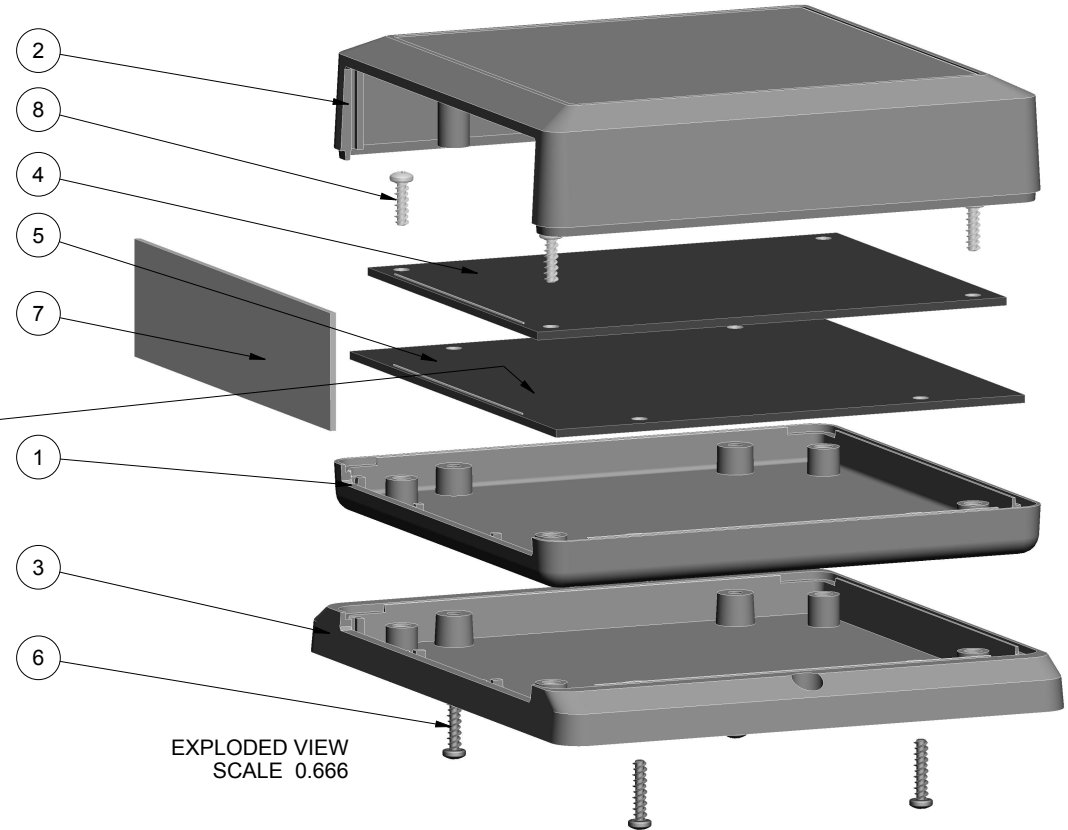

EXPLODED VIEW
SCALE 0.666

434313(x) CONFIGURATIONS				
	-S	-SW	-F	-FW
434313 COVER	1	1		
434313 COVER w/ FACEPLATE			1	1
434313 BASE	1			
434313 BASE w/ FACEPLATE			1	
434313 WALL BASE		1		
434313 WALL BASE w/ FACEPLATE				1
#4 HiLo SCREW .500"	4	4	4	4
434313 FACEPLATE			1	1

ITEM	FILE NAME	DESCRIPTION	MATERIAL	COLOR	QTY.
8	NO_4_375_SCREW	No4 HiLo x .375" - PCB	#4 HiLo x 3/8"	SOLD SEPARATELY	4
7	434313_FACEPLATE	434313 FACEPLATE - STANDARD	ALUMINUM	INCLUDED	1
6	NO_4_500_SCREW	No4 HiLo x .500" - ASSEMBLY	#4 HiLo x 1/2"	INCLUDED	4
5	434313_PCB-4X4	434313 PCB - REFERENCE	.062" THICK	CUSTOMER SUPPLIED	1
4	434313_PCB-4X3	434313 PCB - REFERENCE	.062" THICK	CUSTOMER SUPPLIED	1
3	434313_WALL-BASE	434313 WALL - STANDARD	ABS	BLACK or WHITE	1
2	434313_COVER	434313 COVER - STANDARD	ABS	BLACK or WHITE	1
1	434313_BASE	434313 BASE - STANDARD	ABS	BLACK or WHITE	1

BILL OF MATERIALS

THIRD ANGLE PROJECTION
DO NOT SCALE DRAWING

NOTICE: THE INFORMATION AND DATA CONTAINED HEREIN IS CONSIDERED PROPRIETARY TO ALLTEC INTEGRATED MFG INC & SHALL REMAIN THE EXCLUSIVE PROPERTY OF ALLTEC INTEGRATED MFG INC. THE HOLDER WILL ASSUME CUSTODY AND CONTROL THAT THIS DOCUMENT WILL NOT BE COPIED, REPRODUCED, OR DISCLOSED WITHOUT THE EXPRESS WRITTEN CONSENT OF ALLTEC INTEGRATED MFG INC. THIS DOCUMENT DOES NOT CONSTITUTE A GRANT TO MANUFACTURE ANY ITEMS.
© 2017

TOLERANCES: UNLESS OTHERWISE SPECIFIED DIMENSIONS ARE IN U.S. INCHES.
X.XX = .015 X.XXXX = .001
X.XXX = .010 X.X" = 1"

NEW AGE ENCLOSURES
Customer's Part No: 434313X

APPROVAL	BY	DATE
CHECK		
ENG.		
SCALE	AS NOTED	

DRAWN BY
M BOYER
2009-Aug-24

NEW AGE ENCLOSURES
2240 South Thornburg Street Santa Maria, CA. 93455
ph. (805) 595-1310 fax (805) 595-1024
www.newageenclosures.com

SQUARE UTIL. - STANDARD
SXX-434313X-XXX

SIZE	DRAWING NAME	SHEET	REV.DOC
A	434313X_R2_1	1 OF 8	2.1

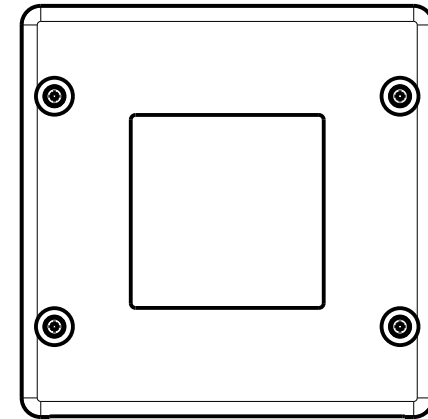
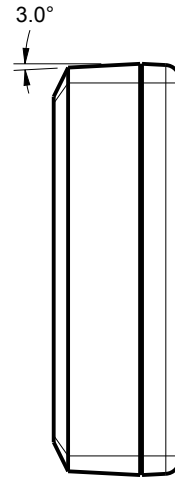
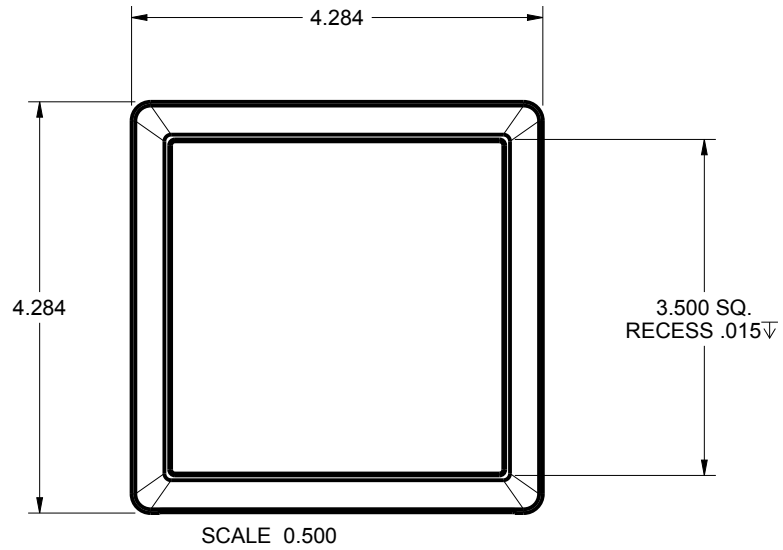

THIS ENCLOSURE CAN BE MOLDED WITH OR WITHOUT THE FACEPLATE OPENING. ASK YOUR SALES REP FOR DETAILS.

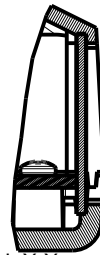
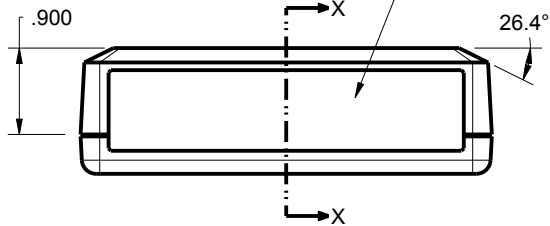

SECTION X-X
SCALE 1.000

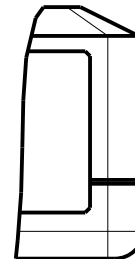

DETAIL A
SCALE 1.000

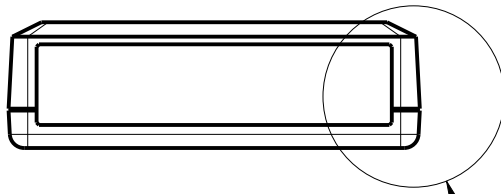

SEE DETAIL A

TOLERANCES: UNLESS OTHERWISE SPECIFIED
DIMENSIONS ARE IN U.S. INCHES.
X.XX = .015 X.XXXX = .001
X.XXX = .010 X.X° = 1°

NEW AGE ENCLOSURES

Customer's Part No: 434313X

APPROVAL	BY	DATE
CHECK		
ENG.		
SCALE	AS NOTED	

DRAWN BY
M BOYER

2009-Aug-24

NEW AGE ENCLOSURES

2240 South Thornburg Street Santa Maria, CA. 93455
ph. (805) 595-1310 fax (805) 595-1024
www.newageenclosures.com

SQUARE UTIL. - STANDARD
SXX-434313X-XXX

SIZE A
DRAWING NAME
434313X_R2_1

SHEET 2 OF 8
REV.DOC 2.1

434313 COVER

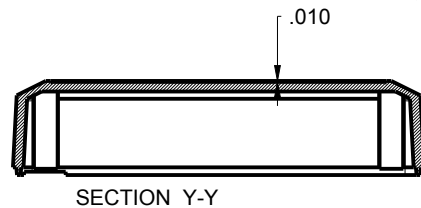
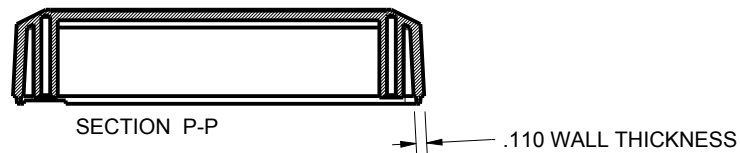
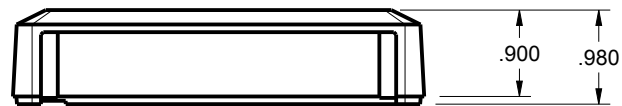
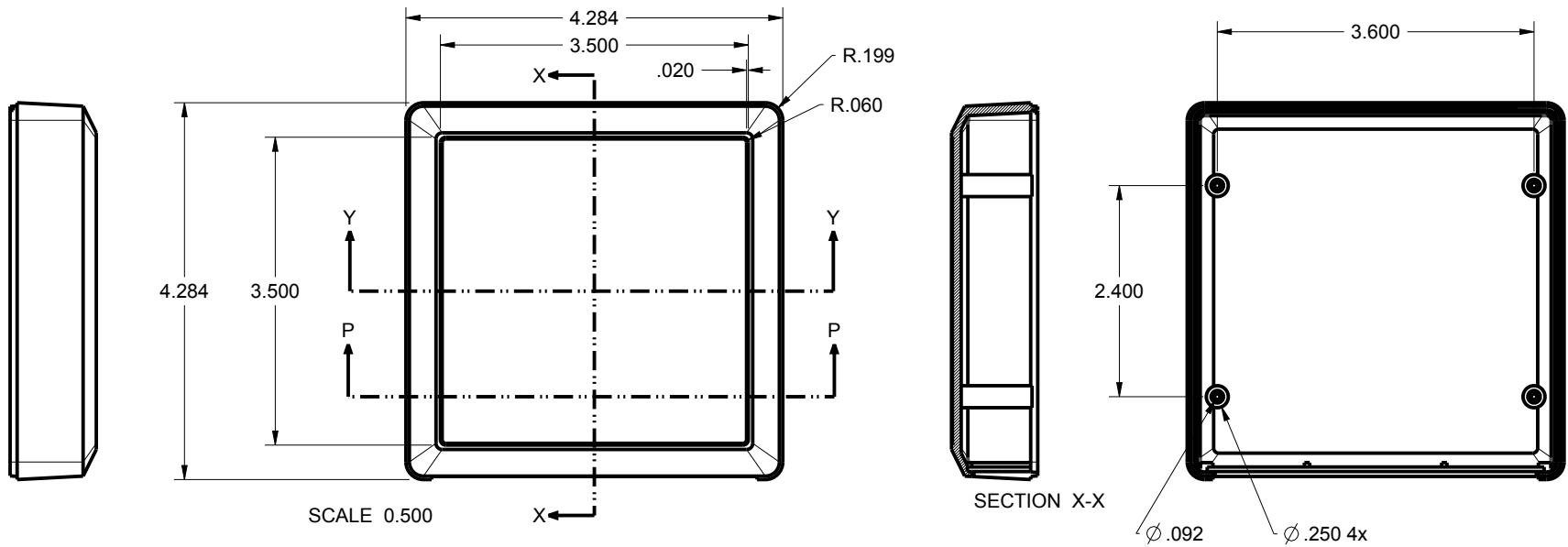

TOLERANCES: UNLESS OTHERWISE SPECIFIED
DIMENSIONS ARE IN U.S. INCHES.
X.XX = .015 X.XXXX = .001
X.XXX = .010 X.X° = 1°

NEW AGE ENCLOSURES
Customer's Part No: 434313X

APPROVAL	BY	DATE
CHECK		
ENG.		
SCALE	AS NOTED	

DRAWN BY
M BOYER
2009-Aug-24

NEW AGE ENCLOSURES
2240 South Thornburg Street Santa Maria, CA. 93455
ph. (805) 595-1310 fax (805) 595-1024
www.newageenclosures.com

SQUARE UTIL. - STANDARD
SXX-434313X-XXX

SIZE A	DRAWING NAME 434313X_R2_1	SHEET 3 OF 8	REV.DOC 2.1
-----------	------------------------------	-----------------	----------------

434313 WALL

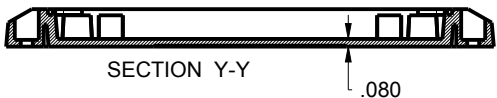
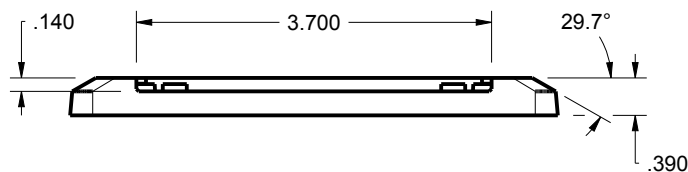
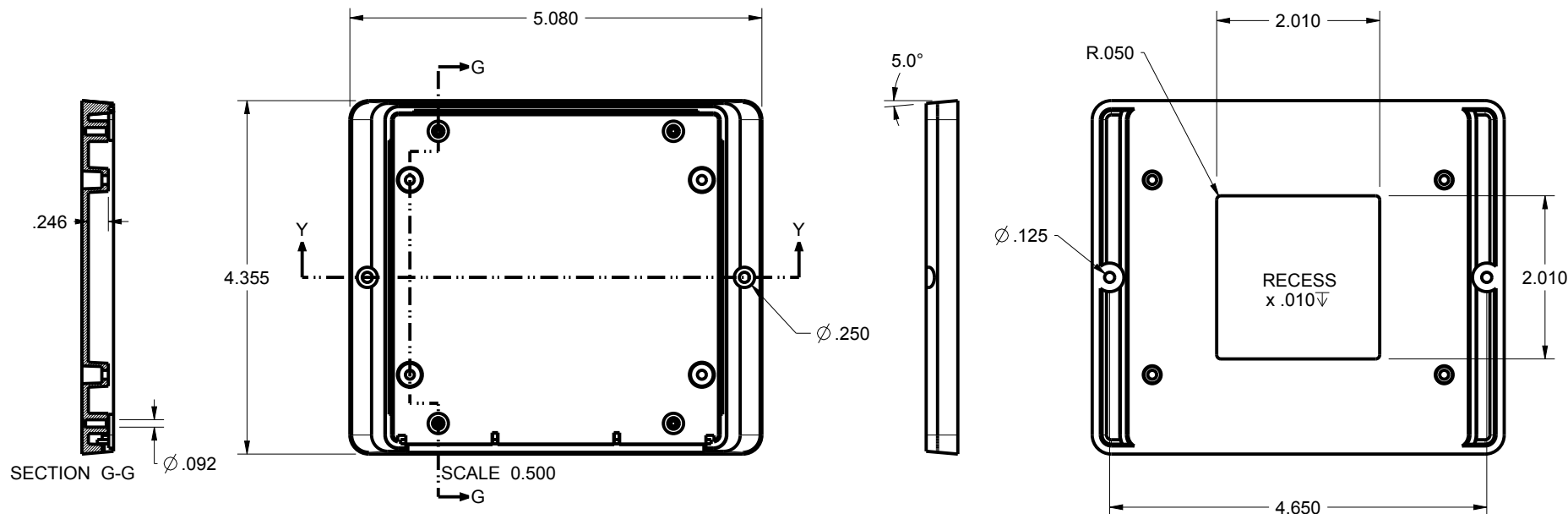

TOLERANCES: UNLESS OTHERWISE SPECIFIED DIMENSIONS ARE IN U.S. INCHES. X.XX = .015 X.XXXX = .001 X.XXX = .010 X.X° = 1°		NEW AGE ENCLOSURES	
NEW AGE ENCLOSURES		2240 South Thornburg Street Santa Maria, CA. 93455 ph. (805) 595-1310 fax (805) 595-1024 www.newageenclosures.com	
Customer's Part No: 434313X			
APPROVAL	BY	DATE	
CHECK			
ENG.			
SCALE	AS NOTED		
DRAWN BY	2009-Aug-24	SIZE	DRAWING NAME
M BOYER		A	434313X_R2_1
		SHEET	REV.DOC
		5 OF 8	2.1

SQUARE UTIL. - STANDARD
SXX-434313X-XXX

434313 FACE PLATE

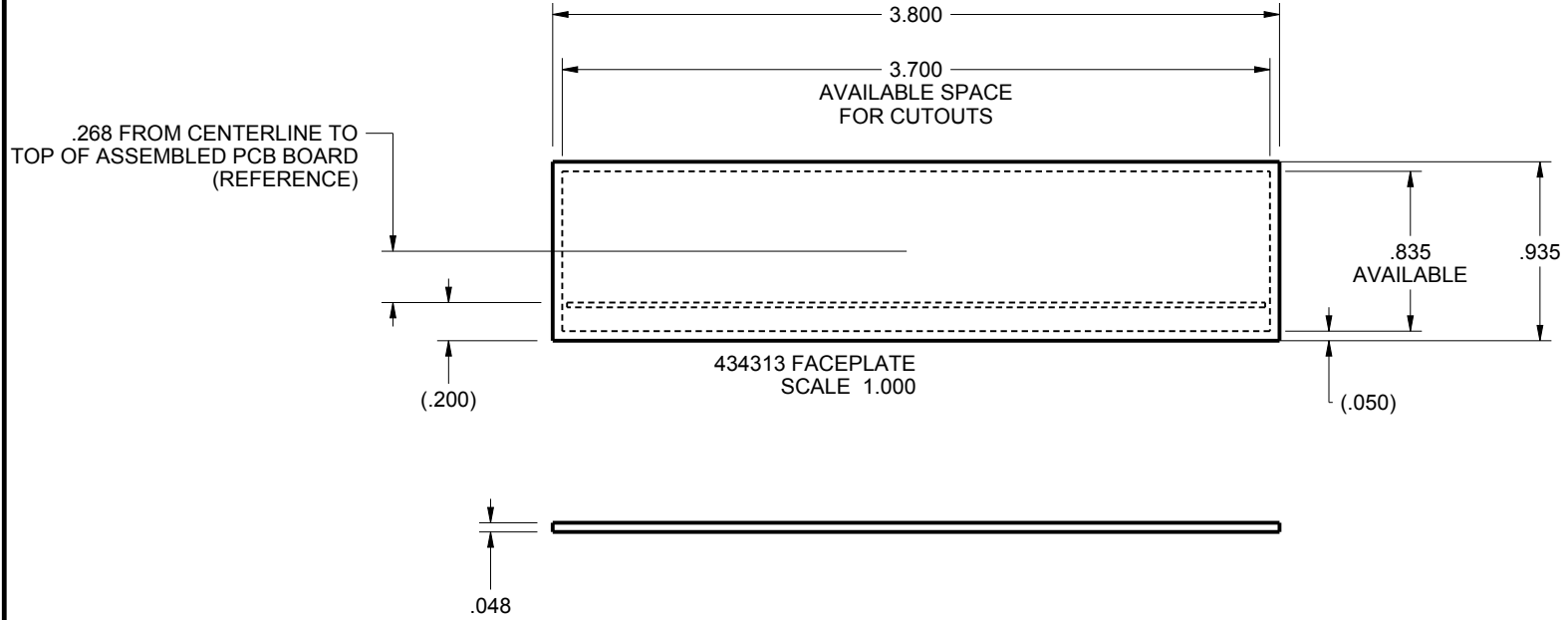

TOLERANCES: UNLESS OTHERWISE SPECIFIED
DIMENSIONS ARE IN U.S. INCHES.
X.XX = .015 X.XXXX = .001
X.XXX = .010 X.X° = 1°

NEW AGE ENCLOSURES
Customer's Part No: 434313X

APPROVAL	BY	DATE
CHECK		
ENG.		
SCALE	AS NOTED	

DRAWN BY	2009-Aug-24
M BOYER	

NEW AGE ENCLOSURES
2240 South Thornburg Street Santa Maria, CA. 93455
ph. (805) 595-1310 fax (805) 595-1024
www.newageenclosures.com

**SQUARE UTIL. - STANDARD
SXX-434313X-XXX**

SIZE	DRAWING NAME	SHEET	REV.DOC
A	434313X_R2_1	6 OF 8	2.1

434313 PCB - CUSTOMER SUPPLIED
 PCB SIZES ARE RECOMMENDATIONS ONLY. FINAL SIZES AND VERIFICATION OF IT'S FIT ARE THE SOLE RESPONSIBILITY OF THE OEM.
 SEE SHEET 4 FOR POST CLEARANCE DETAILS.
 ENCLOSURE DESIGNED TO ACCOMODATE ONE OF THE TWO PCB CONFIGURATIONS SHOWN BELOW (NOT BOTH AT THE SAME TIME).

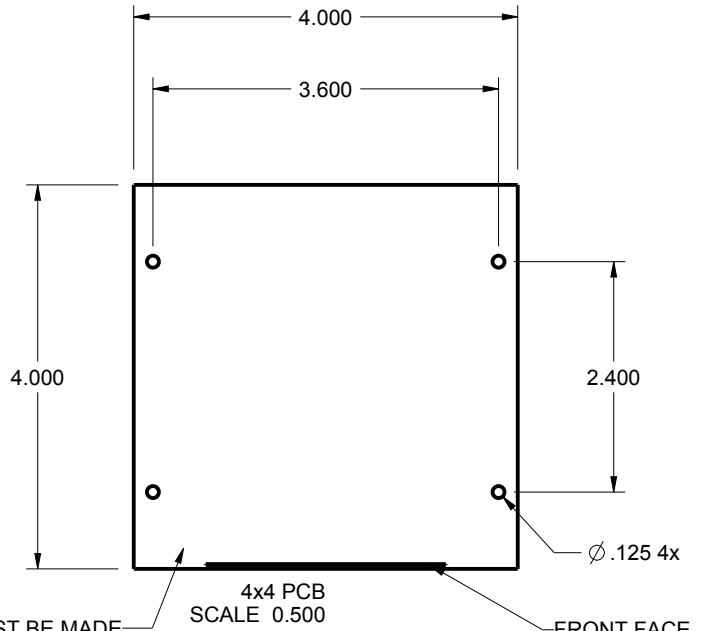

ALLOWANCES MUST BE MADE FOR THE EXTRA PCB POSTS IN ENCLOSURE OR POSTS SHOULD BE CLIPPED BY CUSTOMER.

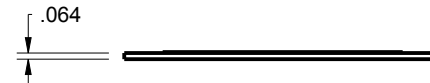
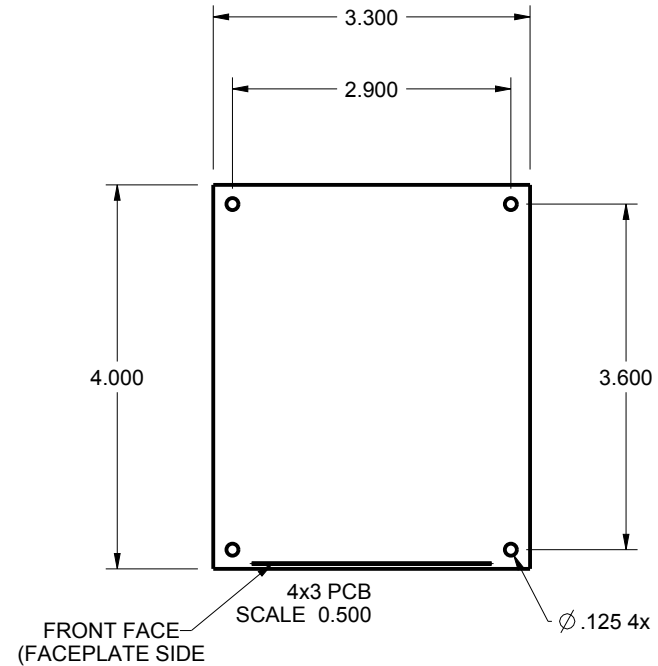
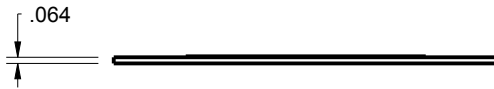

TOLERANCES: UNLESS OTHERWISE SPECIFIED DIMENSIONS ARE IN U.S. INCHES. X.XX = .015 X.XXXX = .001 X.XXX = .010 X.X° = 1°		NEW AGE ENCLOSURES 2240 South Thornburg Street Santa Maria, CA. 93455 ph. (805) 595-1310 fax (805) 595-1024 www.newageenclosures.com	
NEW AGE ENCLOSURES Customer's Part No: 434313X			
APPROVAL	BY	DATE	SQUARE UTIL. - STANDARD SXX-434313X-XXX
CHECK			
ENG.			
SCALE	AS NOTED		
DRAWN BY	2009-Aug-24	SIZE	DRAWING NAME
M BOYER		A	434313X_R2_1
		SHEET	REV.DOC
		7 OF 8	2.1

2nd OPERATION DETAILS

NEW AGE ENCLOSURES DELIVERS YOUR ENCLOSURE MARKET-READY WITH IN-HOUSE
CNC MACHINING, PAD PRINTING, ASSEMBLY, AND FULFILLEMENT.
ALL SURFACES AND AREAS ARE AVAILABLE FOR CNC ALTERATION BY NEW AGE ENCLOSURES
CALL (805) 595-1310 FOR PRICING AND SCHEDULE.
THE INSIDE RADIUS OF ANY MACHINED FEATURES SHOULD BE NO SMALLER THAN .031"

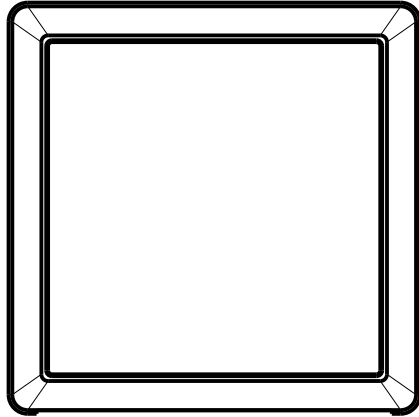

434313 COVER
SCALE 0.500

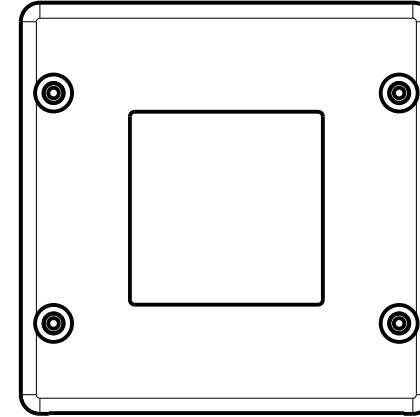

434313 BASE
SCALE 0.500

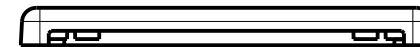

SXX-434313-XXX COVER - ABS, BLACK

STEP NO	DESCRIPTION	CUTTER	FIXTURE	ORIENTATION	PROGRAM
1-C-C1	-	T2 = .062" EM	326	-	o1000
2-C-C2	-	T2 = .062" EM	326	-	o1000
3-C-C3	-	T2 = .062" EM	326	-	o1000

SXX-434313-XXX BASE - ABS, BLACK

STEP NO	DESCRIPTION	CUTTER	FIXTURE	ORIENTATION	PROGRAM
1-B-C1	-	T2 = .062" EM	234	-	o1000
2-B-C2	-	T2 = .062" EM	234	-	o1000
3-B-C3	-	T2 = .062" EM	234	-	o1000

TOLERANCES: UNLESS OTHERWISE SPECIFIED
DIMENSIONS ARE IN U.S. INCHES.
X.XX = .015 X.XXXX = .001
X.XXX = .010 XX° = 1°

NEW AGE ENCLOSURES

Customer's Part No: 434313X

APPROVAL	BY	DATE
CHECK		
ENG.		
SCALE	AS NOTED	
DRAWN BY	2009-Aug-24	
M BOYER		

NEW AGE ENCLOSURES

2240 South Thornburg Street Santa Maria, CA. 93455
ph. (805) 595-1310 fax (805) 595-1024
www.newageenclosures.com

SQUARE UTIL. - STANDARD SXX-434313X-XXX

SIZE	DRAWING NAME	SHEET	REV.DOC
A	434313X_R2_1	8 OF 8	2.1

Компания «Life Electronics» занимается поставками электронных компонентов импортного и отечественного производства от производителей и со складов крупных дистрибьюторов Европы, Америки и Азии.

С конца 2013 года компания активно расширяет линейку поставок компонентов по направлению коаксиальный кабель, кварцевые генераторы и конденсаторы (керамические, пленочные, электролитические), за счёт заключения дистрибьюторских договоров

Мы предлагаем:

- Конкурентоспособные цены и скидки постоянным клиентам.
- Специальные условия для постоянных клиентов.
- Подбор аналогов.
- Поставку компонентов в любых объемах, удовлетворяющих вашим потребностям.
- Приемлемые сроки поставки, возможна ускоренная поставка.
- Доставку товара в любую точку России и стран СНГ.
- Комплексную поставку.
- Работу по проектам и поставку образцов.
- Формирование склада под заказчика.
- Сертификаты соответствия на поставляемую продукцию (по желанию клиента).
- Тестирование поставляемой продукции.
- Поставку компонентов, требующих военную и космическую приемку.
- Входной контроль качества.
- Наличие сертификата ISO.

В составе нашей компании организован Конструкторский отдел, призванный помогать разработчикам, и инженерам.

Конструкторский отдел помогает осуществить:

- Регистрацию проекта у производителя компонентов.
- Техническую поддержку проекта.
- Защиту от снятия компонента с производства.
- Оценку стоимости проекта по компонентам.
- Изготовление тестовой платы монтаж и пусконаладочные работы.



Тел: +7 (812) 336 43 04 (многоканальный)
Email: org@lifeelectronics.ru