



TQM8M9079

500-2700 MHz Variable Gain Amplifier

Product Overview

The TQM8M9079 is an analog controlled variable gain amplifier (VGA) which operates from 500 to 2700 MHz. The VGA is able to provide broadband performance with +29 dBm OIP3 and +16 dBm P1dB over a wide frequency range while only consuming 95 mA current.

The TQM8M9079 integrates two broadband gain blocks with a voltage variable attenuator. The three stages are individually accessible via package I/O contacts. This permits full flexibility to insert other components or filters between the stages.

The TQM8M9079 is packaged in a RoHS-compliant, compact 5x5 mm surface-mount leadless package. Superior thermal design allows the product to have a minimum MTTF rating of 1000 years at a mounting temperature of +85° C.

The TQM8M9079 is targeted for use in wireless infrastructure, IF gain control in point-to-point applications, and for general purpose wireless.

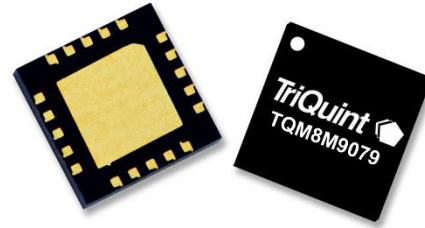

20 Pin 5x5 mm leadless SMT Package

Key Features

- Integrates Amp + VVA + Amp functionality
- 500–2700 MHz Bandwidth
- 38 dB Gain (max gain setting)
- 4.0 dB Noise Figure
- +16 dBm P1dB
- +29 dBm OIP3
- +5V Supply Voltage
- Low Current

Functional Block Diagram

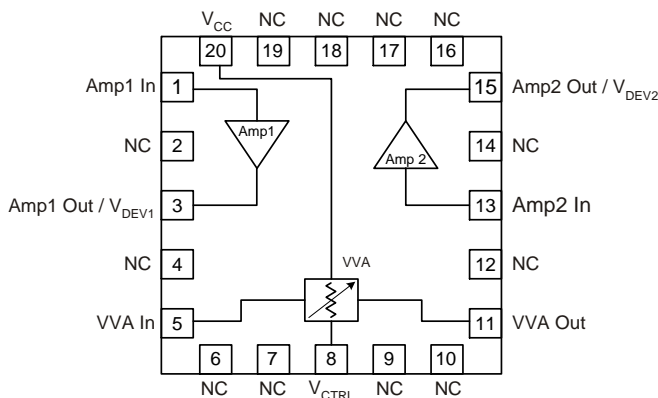

Top View

Applications

- Wireless Infrastructure
- LTE / WCDMA / CDMA / EDGE
- PtP IF Gain Control
- General Purpose Wireless

Ordering Information

Part No.	Description
TQM8M9079TR13	2500 pieces on a 13" reel
TQM8M9079-PCB	500–2700 MHz Evaluation Board

Absolute Maximum Ratings

Parameter	Rating
Storage Temperature	-65 to 150°C
RF Input Power, CW, 50Ω, T=25°C	+24 dBm
Amplifier Voltage ($V_{DEV1,2}$)	+4.5 V
Control Voltage (V_{CTRL})	+6 V

Operation of this device outside the parameter ranges given above may cause permanent damage.

Recommended Operating Conditions

Parameter	Min	Typ	Max	Units
Control Voltage (V_{CTRL})	0.5		5	V
T_{CASE}	-40		+85	°C
T_j for $>10^6$ hours MTTF			+170	°C

Electrical specifications are measured at specified test conditions. Specifications are not guaranteed over all recommended operating conditions.

Electrical Specifications

Test conditions unless otherwise noted: $V_{CC}=+5V$, $R_{BIAS}=24\Omega$, Maximum gain setting, Temp.=+25°C

Parameter	Conditions	Min	Typ	Max	Units
Operational Frequency Range		500		2700	MHz
Test Frequency			2140		MHz
Gain		35	38		dB
Gain Variation Range	Note 1	25	30		dB
Input Return Loss			11		dB
Output Return Loss			20		dB
Output IP3	$P_{out}=0$ dBm/tone, $\Delta f=1$ MHz	+25	+29		dBm
Output P1dB			+16		dBm
Noise Figure			4.0		dB
Amplifier Current	Note 2	77	95	117	mA
VVA Current (Pin 8)	Note 3		3.6		mA
Thermal Resistance, θ_{JC}	Junction to backside paddle			61	°C/W

Notes:

- The Gain variation range is measured as the difference in gain with $V_{CTRL} = 5$ V and $V_{CTRL} = 0$ V.
- Amp1 current (pin 3) and Amp2 current (pin 15) are typically 47.5 mA in each
- VVA typical current is < 1 mA for min attenuation and 3.6 mA for max attenuation

TQM8M9079-PCB Evaluation Board (500–2700 MHz)

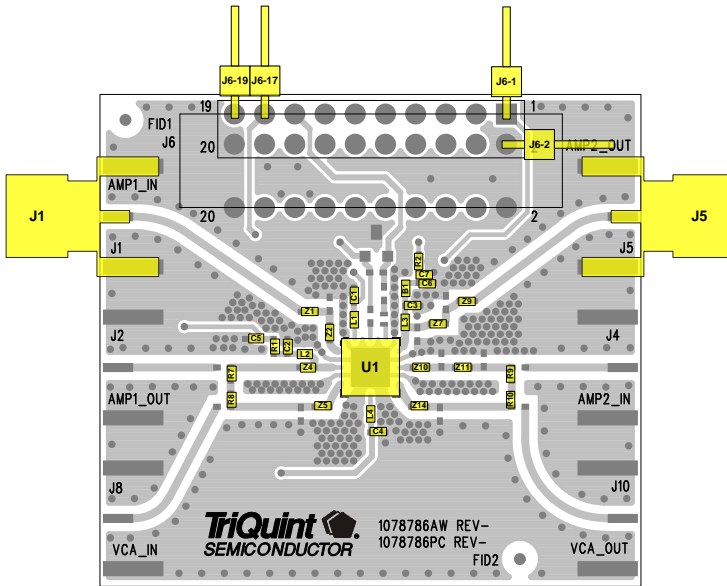

Notes:

1. See Evaluation Board PCB Information section for material and stack-up.
2. 0 Ω jumpers are not shown on the schematic and may be replaced with copper trace in the target application layout.

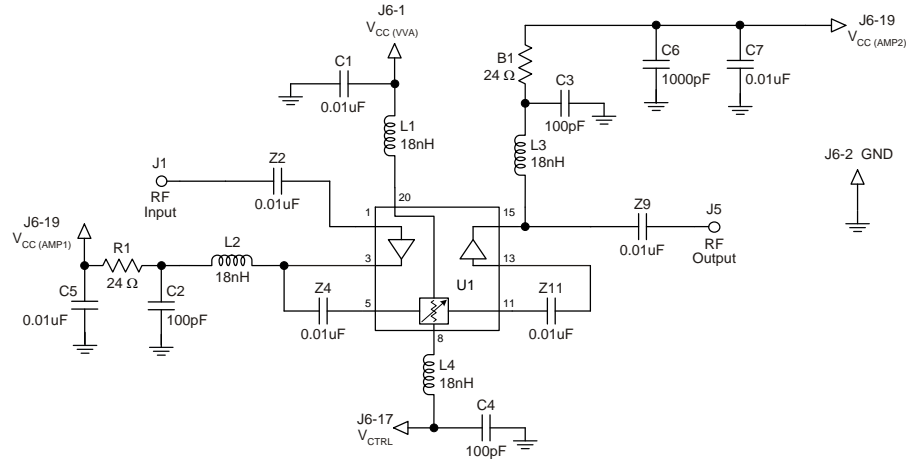

Bill of Material – TQM8M9079-PCB

Reference Des.	Value	Description	Manuf.	Part Number
N/A	N/A	Printed Circuit Board	Qorvo	1078786
U1	n/a	Variable Gain Amplifier	Qorvo	TQM8M9079
B1, R1	24 Ω	Res., Chip, 0402, 5%, 1/16W	various	
L1, L2, L3, L4	18 nH	Inductor, 0402, 5%, 3.1 GHz SRF	CoilCraft	0402CS-18NXJL
R2, R7, R8, R9, R10, Z1, Z5, Z7, Z10, Z14	0 Ω	Res., Chip, 0402, 5%, 1/16W	various	
C1, C5, C7, Z2, Z4, Z9, Z11	0.01 uF	Res., Chip, 0402, 5%, 1/16W	various	
C2, C3, C4,	100 pF	Cap., Chip, 0402, 5%, 50V, NPO/COG	various	
C6	1000 pF	Cap., Chip, 0402, 10%, 50V, X5R	various	
Z8	0.5 pF	Cap., Chip, 0402, 5%, 50V, NPO/COG	various	

Typical Performance – TQM8M9079-PCB

Test conditions unless otherwise noted: $V_{CC} = +5\text{ V}$, $R_{BIAS}=24\Omega$, Maximum Gain Setting, Temp= 25°C

Parameter	Typical Value					Units
Frequency	500	900	1900	2140	2700	MHz
Gain	39.6	39.8	37.9	38.0	32.6	dB
Input Return Loss	9.1	11.0	16.7	11.2	9.6	dB
Output Return Loss	5.1	8.0	19.7	20.2	11.2	dB
Output IP3 (note 1)	+30.3	+30.4	+29.4	+29.1	+28.9	dBm
Output P1dB	+15.8	+15.9	+15.7	+15.7	+14.9	dBm
Noise Figure (note 2)	4.0	3.9	4.0	4.1	4.3	dB

Notes:

1. IIP3 measured with two tones at an input power of +0 dBm / tone separated by 1 MHz.
2. Evaluation board PCB losses de-embedded.

Performance Plots – TQM8M9079-PCB

Test conditions unless otherwise noted: $V_{CC} = +5\text{ V}$, $R_{BIAS}=24\Omega$, Maximum Gain Setting, 50 Ω system.

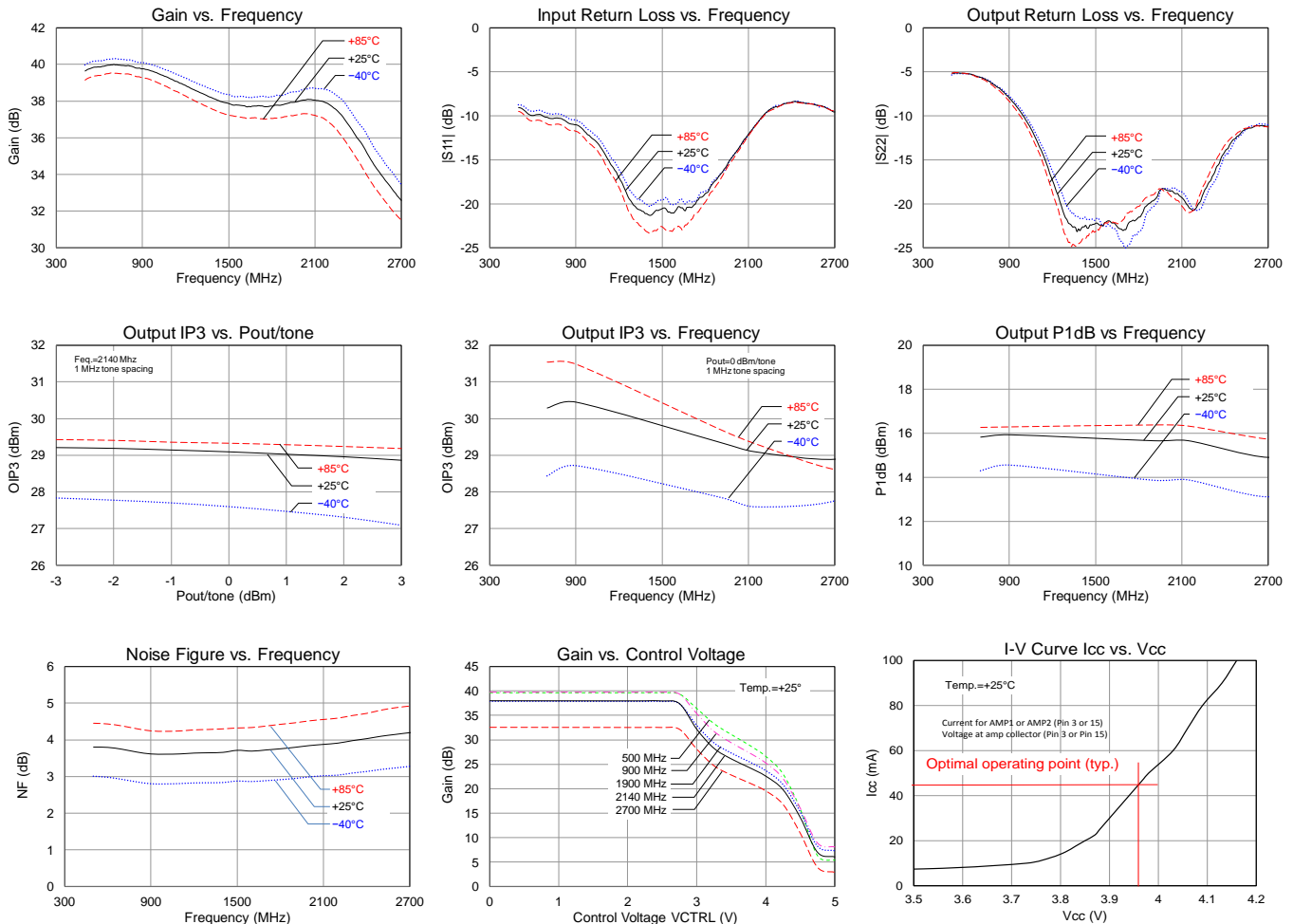

Detailed Device Description

The TQM8M9079 is a 50 Ω internally matched analog controlled variable gain amplifier (VGA) which operates from 500 to 2700 MHz. The amplifier module features the integration of a general purpose amplifier with high dynamic range, a voltage variable attenuator (VVA), along with another general purpose amplifier as shown in the functional diagram below. The VGA is able to provide broadband performance with +29 dBm OIP3 and +16 dBm P1dB over a wide frequency range while only consuming 95 mA current. The three stages are individually accessible via package I/O contacts. This permits full flexibility to insert other components or filters between the stages.

Functional Schematic Diagram

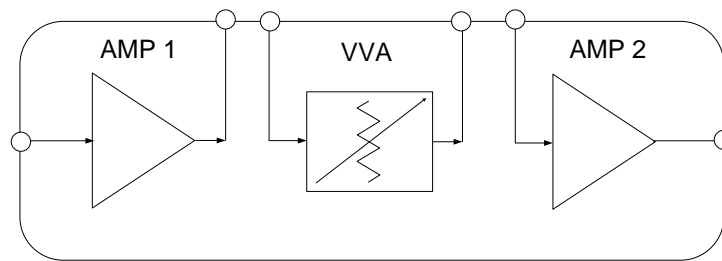

AMP1 / AMP2

AMP1 and AMP2 are general purpose high dynamic range amplifiers in the VGA module. The two amplifiers are identical and provide 20.3 dB gain, +15.7 dBm P1dB, +29.4 dBm OIP3 at 1.9 GHz while only drawing 45 mA current per amplifier. AMP1 and AMP2 each consist of a Darlington-pair amplifier and are unconditionally stable. They are internally matched for both input and output to 50 ohms. Only DC-blocking capacitors, a bias resistor, and an inductive RF choke are required for operation.

VVA (Voltage Variable Attenuator)

The VVA offers 31 dB of attenuation range while providing high linearity (+45 IIP3) over the entire attenuation range. A V_{CTRL} pin provides for an analog voltage that sets the amount of attenuation in the module. 5.0Vctl represents the highest attenuation state. As the voltage is decreased, the amount of attenuation will decrease. At 0.0Vctl the VVA has 2.6 dB of insertion loss while drawing only 2 mA of supply current from the 5V supply. The typical control current is around 4 mA. The VVA is symmetric; therefore, either pin (pin7 or pin 10) can be used as the RF input or output. The VVA input and output ports are DC blocked internally to the module.

Chain Analysis Table

This table provides the typical performance of individual stages in the module as well as overall module performance. Frequency = 1900 MHz.

Parameter	AMP1	VVA	AMP2	Overall Module	Units
Gain	20.3	-2.6	20.3	38	dB
NF	3.9	2.6	3.9	4.0	dB
OIP3	29.4	42	29.4	29.4	dBm
P1dB	15.7	22	15.7	15.7	dBm
Icc	45	6.0*	45	96	mA

Note: * 2mA V_{CC} + 4 mA V_{CTRL}

Pin Configuration and Description

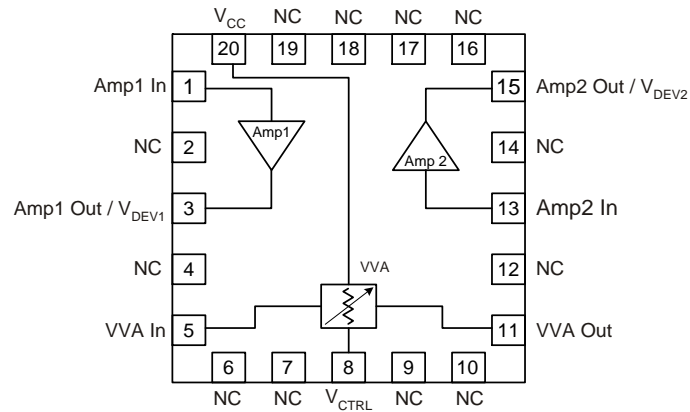

Pin No.	Symbol	Description
1	Amp1 In	RF input (Amp1). DC blocking capacitor required.
2, 4, 6, 7, 9, 10, 12, 14, 16, 17, 18, 19	NC (No Connect)	No electrical connection. Land pads should be provided for PCB mounting integrity.
3	Amp1 Out/V _{DEV1}	RF output / DC bias (Amp1), Bias resistor required (R _{BIAS})
5	VVA In	RF input (VVA). DC blocking capacitor required.
8	V _{CTRL}	Analog input for voltage controlled amplifier
11	VVA Out	RF output (VVA). DC blocking capacitor required.
13	Amp2 In	RF input (Amp2). DC blocking capacitor required.
15	Amp2 Out/V _{DEV2}	RF output / DC bias (Amp2), Bias resistor required (R _{BIAS})
20	V _{CC}	DC supply for voltage variable attenuator.
Backside Paddle	RF/DC GND	RF/DC Ground. Follow recommended via pattern and ensure good solder attach for best thermal and electrical performance.

Evaluation Board PCB Information

TriQuint PCB 1078786 Material and Stack-up

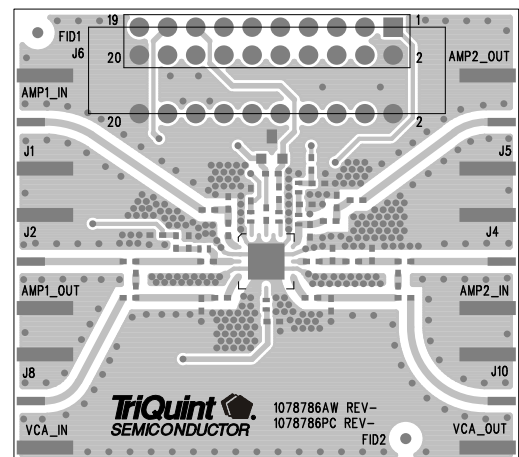
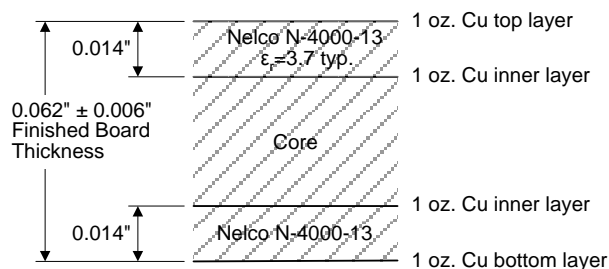

Mechanical Information

Package Marking and Dimensions

Marking: Part number – TQM8M9079
 Year, week, country code – YYWW CCCC
 Trace Code – Up to 6 characters

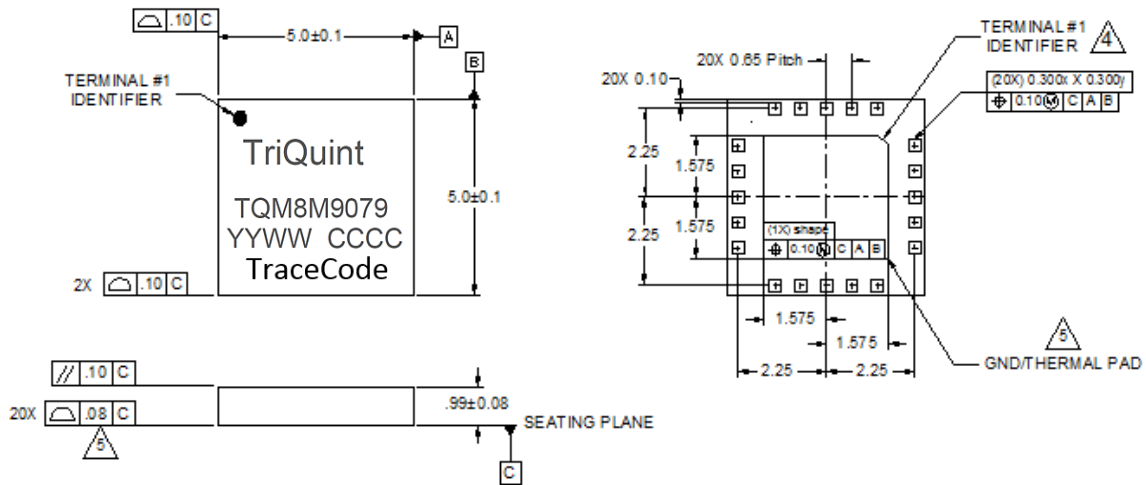

Notes:

1. All dimensions are in millimeters. Angles are in degrees.
2. Dimension and tolerance formats conform to ASME Y14.4M-1994.
3. The terminal #1 identifier and terminal numbering conform to JESD 95-1 SPP-012.
4. Co-planarity applies to the exposed ground/thermal pad as well as the contact pins.

PCB Mounting Pattern

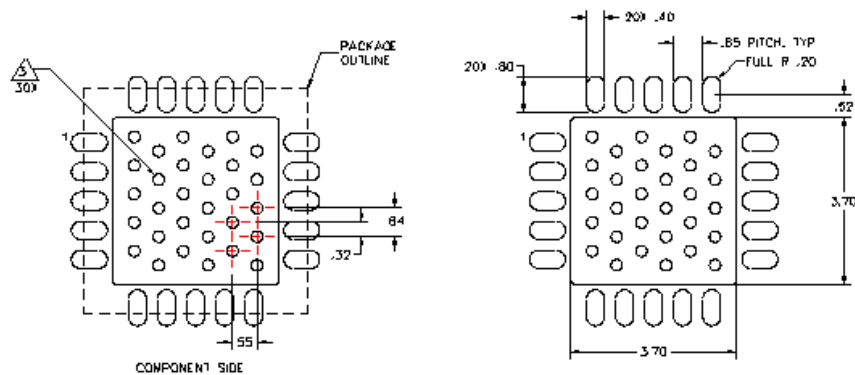

Notes:

1. All dimensions are in millimeters. Angles are in degrees.
2. Use 1 oz. copper minimum for top and bottom layer metal.
3. We recommend a 0.35 mm (#80/.0135") diameter bit for drilling via holes and a final plated thru diameter of 0.25 mm (0.10").
4. Ensure good package backside paddle solder attach for reliable operation and best electrical performance.

Handling Precautions

Parameter	Rating	Standard
ESD – Human Body Model (HBM)	Level 1B	ESDA / JEDEC JS-001-2012
ESD – Charged Device Model (CDM)	Level C3	JEDEC JESD22-C101F
MSL – Moisture Sensitivity Level	Level 3	IPC/JEDEC J-STD-020



Caution!
 ESD-Sensitive Device

Solderability

Compatible with both lead-free (260°C max. reflow temp.) and tin/lead (245°C max. reflow temp.) soldering processes.

Solder profiles available upon request.

Contact plating: Electrolytic plated Au over Ni

RoHS Compliance

This part is compliant with EU 2002/95/EC RoHS directive (Restrictions on the Use of Certain Hazardous Substances in Electrical and Electronic Equipment). This product also has the following attributes:

- Product uses RoHS Exemption 7c-I to meet RoHS Compliance requirements
- Halogen Free (Chlorine, Bromine)
- Antimony Free
- TBBP-A (C₁₅H₁₂Br₄O₂) Free
- PFOS Free
- SVHC Free

Contact Information

For the latest specifications, additional product information, worldwide sales and distribution locations:

Web: www.qorvo.com

Tel: 1-844-890-8163

Email: customer.support@qorvo.com

For technical questions and application information:

Email: appsupport@qorvo.com

Important Notice

The information contained herein is believed to be reliable; however, Qorvo makes no warranties regarding the information contained herein and assumes no responsibility or liability whatsoever for the use of the information contained herein. All information contained herein is subject to change without notice. Customers should obtain and verify the latest relevant information before placing orders for Qorvo products. The information contained herein or any use of such information does not grant, explicitly or implicitly, to any party any patent rights, licenses, or any other intellectual property rights, whether with regard to such information itself or anything described by such information. **THIS INFORMATION DOES NOT CONSTITUTE A WARRANTY WITH RESPECT TO THE PRODUCTS DESCRIBED HEREIN, AND QORVO HEREBY DISCLAIMS ANY AND ALL WARRANTIES WITH RESPECT TO SUCH PRODUCTS WHETHER EXPRESS OR IMPLIED BY LAW, COURSE OF DEALING, COURSE OF PERFORMANCE, USAGE OF TRADE OR OTHERWISE, INCLUDING THE IMPLIED WARRANTIES OF MERCHANTABILITY AND FITNESS FOR A PARTICULAR PURPOSE.**

Without limiting the generality of the foregoing, Qorvo products are not warranted or authorized for use as critical components in medical, life-saving, or life-sustaining applications, or other applications where a failure would reasonably be expected to cause severe personal injury or death.

Copyright 2018 © Qorvo, Inc. | Qorvo is a registered trademark of Qorvo, Inc.

Компания «Life Electronics» занимается поставками электронных компонентов импортного и отечественного производства от производителей и со складов крупных дистрибьюторов Европы, Америки и Азии.

С конца 2013 года компания активно расширяет линейку поставок компонентов по направлению коаксиальный кабель, кварцевые генераторы и конденсаторы (керамические, пленочные, электролитические), за счёт заключения дистрибьюторских договоров

Мы предлагаем:

- Конкурентоспособные цены и скидки постоянным клиентам.
- Специальные условия для постоянных клиентов.
- Подбор аналогов.
- Поставку компонентов в любых объемах, удовлетворяющих вашим потребностям.
- Приемлемые сроки поставки, возможна ускоренная поставка.
- Доставку товара в любую точку России и стран СНГ.
- Комплексную поставку.
- Работу по проектам и поставку образцов.
- Формирование склада под заказчика.
- Сертификаты соответствия на поставляемую продукцию (по желанию клиента).
- Тестирование поставляемой продукции.
- Поставку компонентов, требующих военную и космическую приемку.
- Входной контроль качества.
- Наличие сертификата ISO.

В составе нашей компании организован Конструкторский отдел, призванный помогать разработчикам, и инженерам.

Конструкторский отдел помогает осуществить:

- Регистрацию проекта у производителя компонентов.
- Техническую поддержку проекта.
- Защиту от снятия компонента с производства.
- Оценку стоимости проекта по компонентам.
- Изготовление тестовой платы монтаж и пусконаладочные работы.



Тел: +7 (812) 336 43 04 (многоканальный)

Email: org@lifeelectronics.ru