

### Features

- Quad/dual core 3rd Generation Intel® Core™ Processor with Mobile Intel® QM77 Express Chipset
- Up to 16GB 1600MHz DDR3 with ECC support in two SODIMM sockets
- Three Digital Display Interfaces (DDI) for DisplayPort /HDMI/DVI/SDVO
- Seven PCIe x1 (Gen 2), one PCIe x16 (Gen 3) for graphics (or general purpose x8/4/1)
- 2x SATA 6 Gb/s, 2x SATA 3 Gb/s, Gigabit Ethernet, USB 2.0, 4 USB 3.0
- 50% Thicker PCB for high vibration environments
- Extreme Rugged™ operating temperature: -40°C to +85°C (optional)

### Specifications

#### Core System

CPU	3rd Generation Intel® Core™ i7/i3, 22nm process, BGA type i7-3615QE 2.3GHz, 6MB L3 cache, 45W, quad core i7-3612QE 2.1GHz, 6MB L3 cache, 35W, quad core i7-3555LE 2.5GHz, 4MB L3 cache, 25W, dual core i7-3517UE 1.7GHz, 4MB L3 cache, 17W, dual core i3-3217UE 1.6GHz, 3MB L3 cache, 17W, dual core
Memory	Dual channel ECC 1600 MHz DDR3 memory up to 16 GB in dual SODIMM sockets
BIOS	AMI EFI with CMOS backup in 16 Mb SPI flash
Hardware Monitor	Supply voltages and CPU temperature
Debug Interface	XDP SFF-26 extension for ICE debug
Watchdog Timer	Programmable timer range to generate RESET
Expansion Busses	PCI Express x16 (Gen3) bus for discrete graphics solution or general purpose PCI Express (2 x8 or 1 x8 with 2 x4) 7 PCI Express x1: Lanes 0/1/2/3/4/5/6 LPC bus, SMBus (system), I <sup>2</sup> C (user)
Technologies	PAVP 3.0, Intel® AMT 8.0, Intel® VT, Intel® AES-NI, Intel® HT, Intel® HD Graphics with Dynamic Frequency, Intel® Turbo Boost, Dynamic Turbo, Intel® AVX 1.0, Intel® Quick Sync Video

#### Video

Integrated in Processor	Intel® HD Graphics 4000 at 650-1300 MHz
Integrated Video	DirectX 11.0, OpenGL 3.1, and OCL 1.1
Media Processing	Decode (HW JPEG & MJPEG decode), encode (full HW MPEG2 encode), transcode Intel® Clear Video HD Technology + enhanced media processing
VGA Interface	Analog VGA support with 300 MHz DAC Analog monitor support up to QXGA (2048 x 1536) and VGA hot plug
LVDS Interface	Dual channel 18/24-bit LVDS
Digital Display Interface	Three DDI ports supporting HDMI / DVI / DisplayPort or SDVO

#### Audio

Chipset	Integrated in Mobile Intel® QM77 Express chipset
Audio Codec	Implemented on carrier board

#### Ethernet

Chipset	Intel® Gigabit LAN PHY WG82579LM
Speed	10/100/1000 Mbps Ethernet

#### I/O Interfaces

Chipset	Integrated in Mobile Intel® QM77 Express chipset
USB	Supports up to eight ports USB 2.0, 4 USB 3.0
SATA	Two SATA 6 Gb/s, two SATA 3 Gb/s with support for RAID 0,1,5,10

#### Super I/O

Connected to LPC bus on carrier if needed (BIOS supports W83627DHG)

#### TPM (optional)

Chipset	Atmel AT97SC3204-U1A190
Type	TPM 1.2

#### Power

Input Power	AT mode (12 V +/- 5%) and ATX mode (12 V and 5 Vsb +/- 5%)
Power States	Supports S0, S1, S3, S4, S5
Power Consumption	12W typical (i7-36xxQE) 8W typical (i7-3555LE/i7-3517UE/i3-3217UE) S3: 0.85W S5: 0.55W
Smart Battery Support	Yes (BIOS supports LTC4100 and LTC1760)

#### Mechanical and Environmental

Form Factor	PICMG COM.0: Rev 2.1 Type 6
Dimension	Basic size: 125 mm x 95 mm
Board Thickness	0.093" (2.3mm)
Operating Temperature	Standard: 0°C to +60°C Extreme Rugged™: -40°C to +85°C (optional)
Storage Temperature	-55°C to +85°C
Humidity	90% at +60°C non-condensing
Shock	50G peak-to-peak, 11ms duration, MIL-STD-202G Method 213B
Vibration	Operating: 11.96 Grms, 50-20,000 Hz, each axis, MIL-STD-202G Method 214A
Compatibility	PICMG COM Express COM.0 R2.1 Type 6
Certifications	CE, FCC, HALT

#### Operating Systems

Standard Support	Windows 7, Linux
Extended Support (BSP)	Windows XPe/7, WEC 7, Linux, VxWorks 6.9, QNX 6.5, AIDI Library

## Functional Diagram

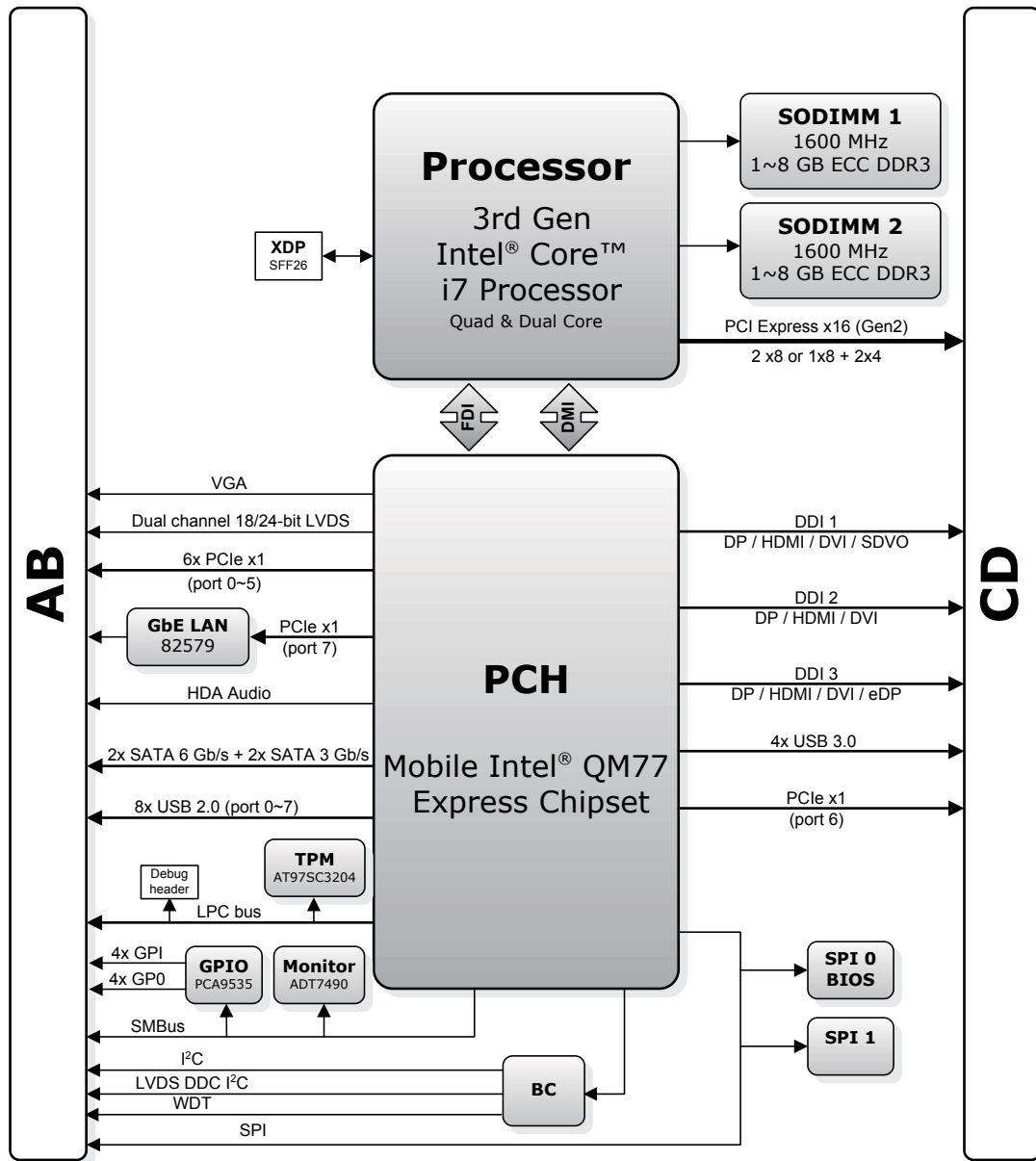

## Ordering Information

### Modules

Model Number	Description/Configuration
Express-IBR-i3-R-3217UE	COM Express® Basic Size Type 6 Module with Intel® Core™ i3-3217UE 1.6GHz 17W Dual Core CPU, two DDR3 ECC SODIMMs supported
Express-IBR-i7-R-3517UE	COM Express® Basic Size Type 6 Module with Intel® Core™ i7-3517UE 1.7GHz 17W Dual Core CPU, two DDR3 ECC SODIMMs supported
Express-IBR-i7-R-3555LE	COM Express® Basic Size Type 6 Module with Intel® Core™ i7-3555LE 2.5GHz 25W Dual Core CPU, two DDR3 ECC SODIMMs supported
Express-IBR-i7-R-3612QE	COM Express® Basic Size Type 6 Module with Intel® Core™ i7-3612QE 2.1GHz 35W Quad Core CPU, two DDR3 ECC SODIMMs supported
Express-IBR-i7-R-3615QE	COM Express® Basic Size Type 6 Module with Intel® Core™ i7-3615QE 2.3GHz 45W Quad Core CPU, two DDR3 ECC SODIMMs supported

### Accessories

Model Number	Description/Configuration
<b>Heat Spreaders</b>	
HTS-IBR-B	Heat-spreader for Express-IBR with threaded standoffs for bottom-mounting
HTS-IBR-BTF	Heat-spreader for Express-IBR with through-hole standoffs for top-mounting
<b>Passive Heatsinks</b>	
THSH-IBR-BTL	Heatsink for Express-IBR with through hole standoffs for top-mounting
<b>Active Heatsink</b>	
THSF-IBR-BTL-CU	Heatsink with FAN for Express-IBR with through-hole standoffs for top-mounting

Компания «Life Electronics» занимается поставками электронных компонентов импортного и отечественного производства от производителей и со складов крупных дистрибьюторов Европы, Америки и Азии.

С конца 2013 года компания активно расширяет линейку поставок компонентов по направлению коаксиальный кабель, кварцевые генераторы и конденсаторы (керамические, пленочные, электролитические), за счёт заключения дистрибьюторских договоров

Мы предлагаем:

- Конкурентоспособные цены и скидки постоянным клиентам.
- Специальные условия для постоянных клиентов.
- Подбор аналогов.
- Поставку компонентов в любых объемах, удовлетворяющих вашим потребностям.
- Приемлемые сроки поставки, возможна ускоренная поставка.
- Доставку товара в любую точку России и стран СНГ.
- Комплексную поставку.
- Работу по проектам и поставку образцов.
- Формирование склада под заказчика.
- Сертификаты соответствия на поставляемую продукцию (по желанию клиента).
- Тестирование поставляемой продукции.
- Поставку компонентов, требующих военную и космическую приемку.
- Входной контроль качества.
- Наличие сертификата ISO.

В составе нашей компании организован Конструкторский отдел, призванный помогать разработчикам, и инженерам.

Конструкторский отдел помогает осуществить:

- Регистрацию проекта у производителя компонентов.
- Техническую поддержку проекта.
- Защиту от снятия компонента с производства.
- Оценку стоимости проекта по компонентам.
- Изготовление тестовой платы монтаж и пусконаладочные работы.



Тел: +7 (812) 336 43 04 (многоканальный)

Email: [org@lifeelectronics.ru](mailto:org@lifeelectronics.ru)