



Expertise Applied | Answers Delivered



SOLAR PRODUCTS CATALOG



SOLAR PRODUCTS

1500 Vdc Products • In-Line Fuses • Protection Relays • Overvoltage Protection

Technical Expertise and Manufacturing Excellence

With over 16.5 million devices installed in photovoltaic power systems, Littelfuse understands the global challenges of the solar market. Littelfuse offers numerous circuit-protection products that are uniquely suited to protect the equipment and systems subject to the harsh environments of photovoltaic installations. Items listed within this catalog, and even newer products available online, represent over 80 years of Littelfuse technical expertise and manufacturing excellence.

The high power research lab in Champaign, Illinois, USA, provides design and test capabilities for up to 1500 Vdc. Littelfuse design engineers and technicians, participate in the global standards committees and understand the applications of photovoltaic systems.

Littelfuse products are manufactured in one of six facilities around the world, supported by a strong network of suppliers and a knowledgeable sales channel. This allows Littelfuse to provide the best products for photovoltaic applications when and where they are needed.



Circuit Protection Products for Photovoltaic Applications

As a global leader in circuit protection, Littelfuse provides a wide selection of fuses, fuse holders, relays & controls, TVS diodes and varistors. These products improve system uptime, sustainability and reliability of photovoltaic power systems. Littelfuse circuit-protection products meet the unique requirements of photovoltaic applications – where issues such as heat, efficiency, longevity and global standards impact the choices in selecting protection options.

In addition to a wide portfolio of circuit-protection products, Littelfuse offers decades of design experience to help address application challenges and achieve regulatory compliance.

FUSES
FUSE HOLDERS
RELAYS & CONTROLS

VARISTORS
TVS DIODES
POWER DISTRIBUTION

Littelfuse App!

Download our free Littelfuse Catalogs and Literature App to keep our products and technical resources at your finger tips!



Visit Littelfuse.com/solar for additional technical specifications, reference materials and the latest updates on new products being developed.

TABLE OF CONTENTS

1 1500 Vdc RATED PRODUCTS

SPXV String Fuses.....	2
SPXI In-Line Fuses.....	3
LPXV Fuse Holders	4



2 1000 Vdc RATED PRODUCTS

SPFJ High Amperage Fuses.....	5
SPF String Fuses.....	6
SPFI In-Line Fuses	7
LFJ1000 Open-Face Fuse Blocks.....	8
SPFR Class R Fuses.....	9
SPFRHV Open-Face Fuse Blocks	9
LPHV Touch-Safe Fuse Holders.....	10



3 600 Vdc RATED PRODUCTS

POWR-Bar Bus Bar.....	11
LPSC / LFPSM Dead-Front fuse holders.....	12
KLKD 10x38mm (Midget) Fuses.....	13
POWR-BLOKS Distribution Blocks	14

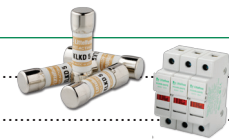

4 OVERVOLTAGE AND SWITCHING ELECTRONIC PRODUCTS

IGBT Power Modules	15
Transient Voltage Suppression (TVS) Diodes.....	16
Overvoltage Suppression Varistors (MOV).....	17

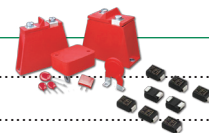

5 PROTECTION RELAY PRODUCTS

SE-601 Ground-Fault Monitor.....	18
EL731 Sensitive Earth-Leakage Relay.....	19



APPENDIX

Solar Products by Application.....	20
------------------------------------	----

SPXV SERIES SOLAR FUSE

1500 Vdc • 6 – 30 A



1



Description

The Littelfuse SPXV solar string fuse is designed specifically for 6-30 A 1500 Vdc applications.

Features/Benefits

- 10 x 85 mm package size
- UL 2579 Listed
- Meets IEC 60269-6 electrical performance requirements
- 30,000 A interrupting rating

Applications

- Inverters
- Combiner boxes

Web Resources

Download technical resources at:
littelfuse.com/spxv

Specifications

Voltage Rating	1500 Vdc
Amperage Rating	6, 8, 10, 12, 15, 20, 25, 30 A
Interrupting Rating	15 kA (UL 2579) 30 kA (Self-Certified)
Time Constant	≤ 1ms
Material	Body: Melamine Caps: Copper Alloy (Nickel Plated)
Approvals	UL 2579 Listed (File: E339112)
Environmental	RoHS Compliant REACH
Country of Origin	Mexico

Part Numbering System

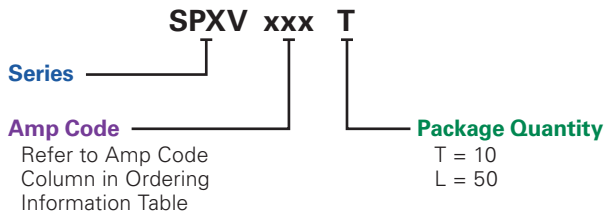

SERIES	AMP	PACKAGE QUANTITY	CATALOG NUMBER	ORDERING NUMBER
SPXV	6	10	SPXV006	SPXV006.T
SPXV	20	50	SPXV020	SPXV020.L

Dimensions mm (inches)

6 – 20 A

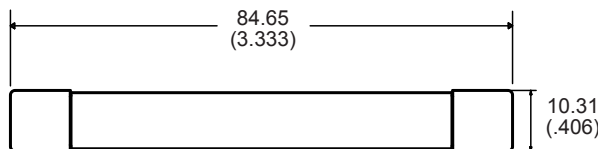

25 – 30 A

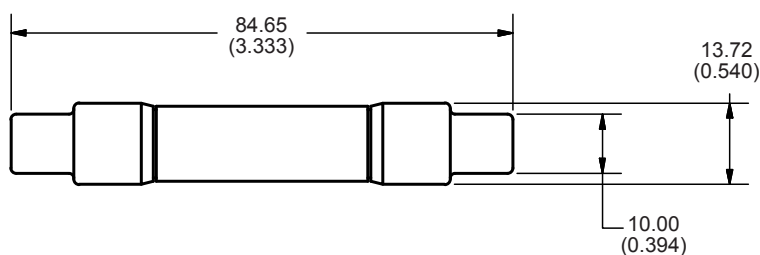

SPXI SERIES IN-LINE SOLAR FUSE

1500 Vdc • 2.5-30 A (Patent Pending)



Description

The Littelfuse SPXI solar fuse is designed to integrate into an in-line assembly within a wire harness. The fuse provides photovoltaic (PV) protection that meets UL 2579 for photovoltaic applications. The SPXI can be electrically insulated by either overmolding or using approved heat-shrink.

Features/Benefits

- UL 2579 Recognized
- Meets IEC 60269-6 electrical performance requirements
- 30,000 A interrupting rating
- No fuse holder required

Applications

- Photovoltaic wire harness

Recommended Crimping Tool

T&B Sta-Kon ERG4002 or equivalent
Weidmüller HTN 21 or equivalent

Dimensions mm (in)

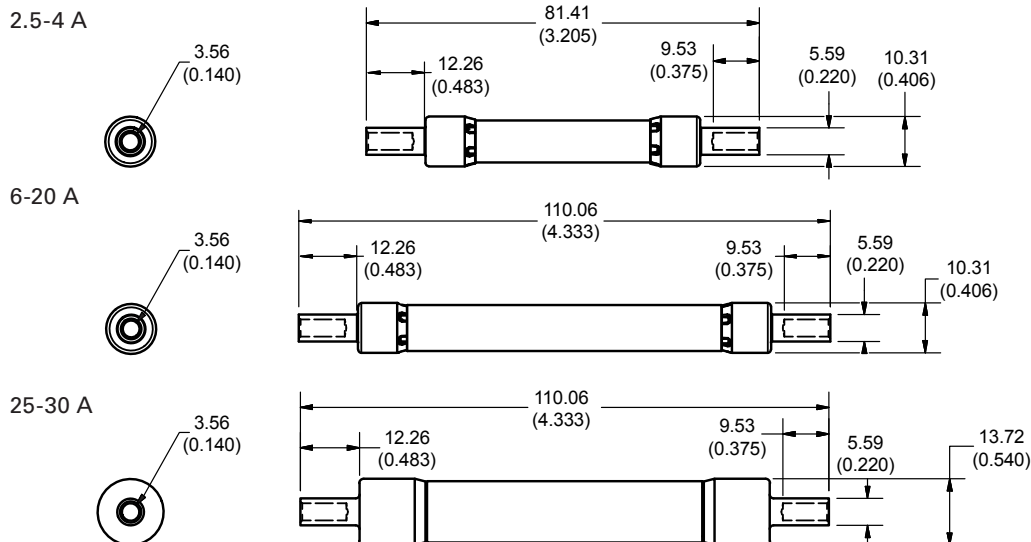

Specifications

Voltage Rating:	1500 Vdc
Amperage Rating:	2.5, 3.5, 4, 6, 8, 10, 12, 15, 20, 25, 30 A
Interrupting Ratings:	15 kA (UL 2579) 30 kA (Self-Certified)
Time Constant	≤ 1ms
Material:	Body: Melamine Caps: Copper Alloy (Nickel Plated)
Approvals:	UL 2579 Recognized (File: E339112)
Environmental:	RoHS Compliant REACH
Country of Origin:	Mexico

Part Numbering System

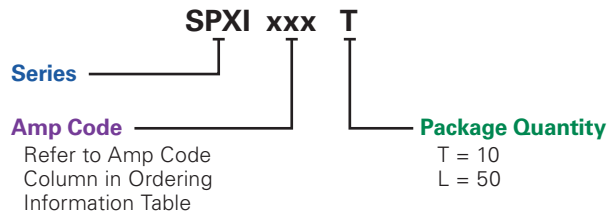

SERIES	AMP	PACKAGE QUANTITY	CATALOG NUMBER	ORDERING NUMBER
SPXI	3.5	10	SPXI03.5	SPXI03.5T
SPXI	4	10	SPXI004	SPXI004.T
SPXI	20	50	SPXI020	SPXI020.L

Web Resources

Download additional technical information and view the complete solar portfolio: littelfuse.com/spxi

LPXV TOUCH-SAFE FUSE HOLDERS

1500 V • 30 A



1



Description

The Littelfuse LPXV fuse holder is designed to hold 1500 V 10x85mm fuses.

Features/Benefits

- Finger-Safe design offers personnel protection
- No fuse pullers or tools required for fuse removal
- 35 mm DIN Rail Mountable
- Compact design

Recommended Fuses

Littelfuse SPXV 1500 V Fuses

Web Resources

Download the complete datasheet and other technical documents: Littelfuse.com/lpxv

Specifications

Voltage Ratings	1500 Vdc
Amperage Rating	30 A
SCCR Rating	15 kA
Fuse Type	10x85mm
Material	Thermoplastic
Flammability Rating	UL94 V-0
Temperature Stability	Body: 125° C Carrier: 140° C
Approvals	UL 4248-18 Listed (File: E345481) IEC 60269-1 & IEC 60269-2
Environmental	RoHS compliant, Lead (Pb) free

Dimensions Inches (mm)

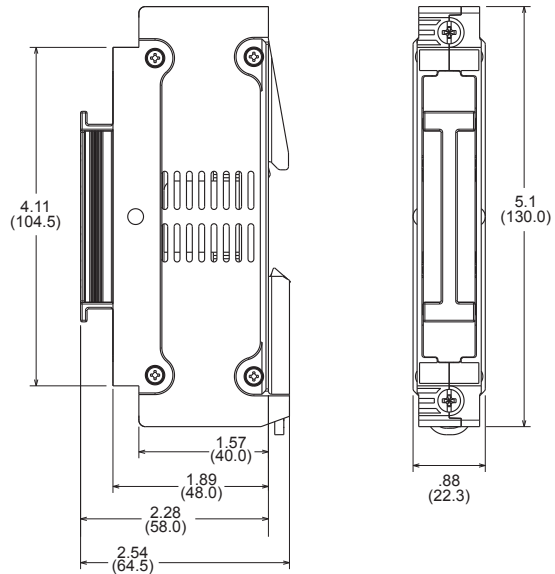

Ordering Information

SERIES	VOLTAGE (Vdc)	POLES	CATALOG NUMBER	ORDERING NUMBER	PACK QTY	TERMINAL INFORMATION				
						TERMINAL TYPE	WIRE TYPE	NUMBER OF WIRES	WIRE SIZE	TORQUE
LPXV	1500	1	LPXV001	LPXV0001Z	5	Box Lug	90° Max CU Only Stranded	1	6-4 AWG (16-25 mm ²)	22-26 lb-in (2.5-3 N-m)
								1	18-8 AWG (.75-10 mm ²)	18-22 lb-in (2-2.5 N-m)
								2*	18-6 AWG (.75-16 mm ²)	18-22 lb-in (2-2.5 N-m)

*Must be the same cross-sectioned size



Look for this logo to indicate products that are used in solar applications. Visit our website littelfuse.com/solar for the latest updates on approvals, certifications, and new products.

SPFJ SERIES SOLAR FUSE

1000 Vdc • 70-450 A



Description

The SPFJ series is the smallest 1000 Vdc 70-450 A photovoltaic fuse available in the market. The SPFJ series is manufactured in Class J case sizes that allows for both fuse holder and busbar mounting configuration. The SPFJ meets both UL and IEC requirements.

Features/Benefits

- Meets UL and IEC photovoltaic standards
- VDE certified specifications
- Small footprint reduces panel size
- Flexibility of fuse holder or busbar mounting
- Higher amperage solar fuses in standard sizes
- UL Listed branch and feeder circuit rated
- Class J case sizes for the 125-450 A ratings

Applications

- Inverters
- Re-combiner boxes

Recommended Fuse Holder

LFJ1000 Solar Series

Web Resources

Download technical documents: Littelfuse.com/spfj

Specifications

Voltage Rating	1000 Vdc 600 Vac (125-450 A)
Amperage Rating	70, 80, 90, 100, 125, 160, 200, 250, 300, 350, 400, 450
Interrupting Rating	AC: 200 kAIC (125-450 A) DC: 70-200 A: 20 kAIC 250-400 A: 10 kAIC 450 A: 20 kAIC
Time Constant	≤ 1ms
Material	Body: Melamine End Bells: Copper Alloy
Approvals	UL 2579 Listed (File: E339112) UL 248-8, Class J (125-450 A) cULus (125-450 A) IEC 60269-6 (125-450 A) VDE Certified (125-450 A) (No. 40033659, 40033660, 40033661)
Environmental	RoHS Compliant
Country of Origin	Mexico

Part Numbering System

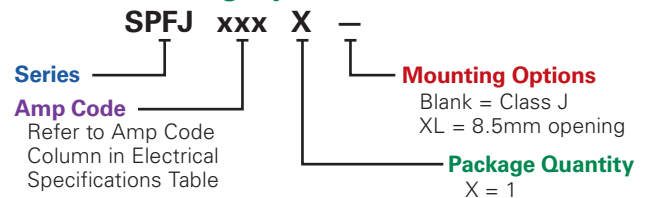

SERIES	AMP	PACKAGE QUANTITY	MOUNTING METHOD	CATALOG NUMBER	ORDERING NUMBER
SPFJ	70	1	CLASS J	SPFJ070	SPFJ070.X
SPFJ	200	1	LARGE	SPFJ200	SPFJ200.XXL

Dimensions Inches (mm)

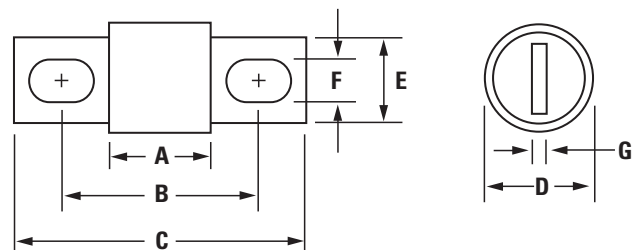

AMPERAGE	DIMENSIONS IN INCHES (MM)						
	A	B	C	D	E	F	G
70-100	3.02 (76.5)	4.38 (111.3)	5.75 (146.1)	1.5 (38.1)	1.125 (28.3)	.335 (8.5)	.189 (4.8)
125-200	3.02 (76.5)	4.38 (111.3)	5.75 (146.1)	1.5 (38.1)	1.125 (28.3)	.281 (7.1)*	.189 (4.8)
250-400	3.37 (85.7)	5.25 (133.4)	7.125 (181.0)	2.0 (50.8)	1.63 (41.3)	.406 (10.3)	.252 (6.4)
450	3.75 (95.3)	5.98 (152.0)	8.0 (203.2)	2.5 (63.5)	2.0 (50.8)	.531 (13.5)	.374 (9.5)

* SPFJ L option = 8.5 mm (UL 2579 approval only)



Look for this logo to indicate products that are used in solar applications. Visit our website Littelfuse.com/solar for the latest updates on approvals, certifications, and new products.

SPF SERIES SOLAR FUSES

1000 Vdc • 1-30 A



Description

The SPF Solar Protection Fuse series has been specifically designed for the protection of photovoltaic (PV) systems. This family of Midget style fuses (10 x 38 mm) can safely protect PV modules and conductors from reverse-overcurrent conditions.

As PV systems have grown in size, so have the corresponding voltage requirements. This increase in system voltage has typically been intended to minimize power loss associated with long conductor runs. Standard circuit protection devices are not designed to completely protect photovoltaic panels. However, the SPF series is UL Listed to safely interrupt faulted circuits up to this demanding voltage level.

Littelfuse offers 14 ampere ratings to match specific requirements in a variety of applications.

Features/Benefits

- Meets UL, IEC and VDE photovoltaic standards
- UL 2579 Listed 1000 Vdc maximum
- 1-30 A ratings available
- 20,000 A Interrupting Rating
- Both PCB mount and dead-front holder options available

Applications

- Inverters
- Combiner boxes
- Battery charge controllers

Recommended Fuse Holders

LPHV 1000 Vdc POWR-Safe Series

Web Resources

Download technical documents: littelfuse.com/spf

Specifications

Voltage Rating	1000 VDC
Ampere Rating	1, 2, 3, 3.5, 4, 5, 6, 8, 10, 12, 15, 20, 25, 30
Max. Interrupting Rating	20 kA
Time Constant	≤ 2ms
Material	Body: Melamine Caps: Copper Alloy
Approvals	UL 2579 Listed (File: E339112) IEC 60269-6 (1-25 A) VDE Certified (No. 40033098)* see specifications on pg. 2 CSA Certified (File: 029862_0_000)
Environmental	RoHS Compliant
Country of Origin	Mexico

Part Numbering System

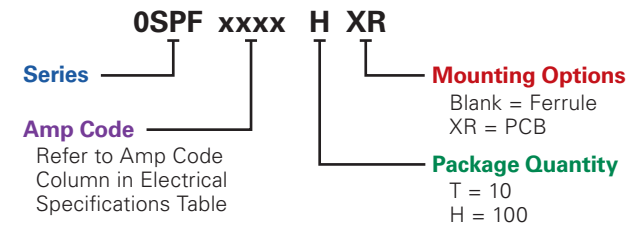

SERIES	AMP	PACKAGE QUANTITY	MOUNTING METHOD	CATALOG NUMBER	ORDERING NUMBER
SPF	2	10	FERRULE	SPF002	OSPF002.T
SPF	3.5	10	FERRULE	SPF03.5	OSPF03.5T
SPF	30	100	PCB TABS	SPF030R	OSPF030.HXR

Dimensions Inches (mm)

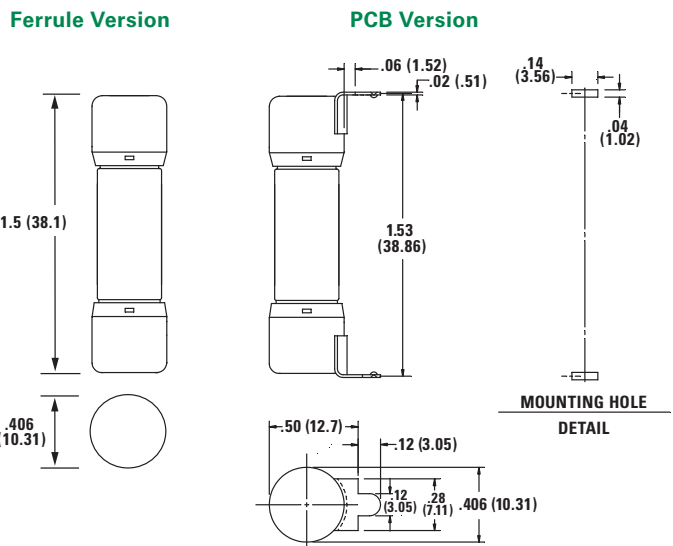

Look for this logo to indicate products that are used in solar applications. Visit our website littelfuse.com/solar for the latest updates on approvals, certifications, and new products.

SPFI SERIES IN-LINE SOLAR FUSE

1000 Vdc • 2-30 A (Patent Pending)



Description

The Littelfuse SPFI solar fuse is designed to integrate into an in-line assembly within a wire harness. The fuse provides photovoltaic (PV) protection that meets UL 2579 for photovoltaic applications. The SPFI can be electrically insulated by either overmolding or using approved heat-shrink.

Features/Benefits

- UL 2579 Recognized
- Meets IEC 60269-6 electrical performance requirements
- 20,000 A Interrupting Rating
- No fuse holder required

Applications

- Photovoltaic wire harness

Specifications

Voltage Rating	1000 Vdc
Amperage Rating	2, 2.5, 3, 3.5, 4, 5, 6, 8, 10, 12, 15, 20, 25, 30 A
Interrupting Rating	20 kA
Time Constant	≤ 1ms
Material	Body: Melamine Caps: Copper Alloy (Nickel Plated)
Approvals	UL 2579 Recognized (File: E339112)
Environmental	RoHS Compliant REACH
Country of Origin	Mexico

Part Numbering System

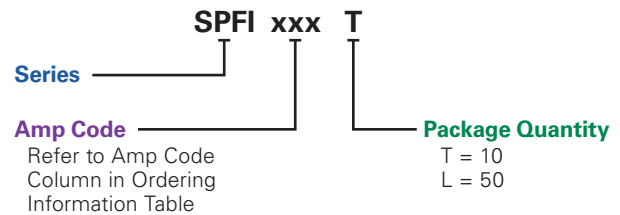

SERIES	AMP	PACKAGE QUANTITY	CATALOG NUMBER	ORDERING NUMBER
SPFI	2	10	SPFI002	SPFI002.T
SPFI	3.5	10	SPFI03.5	SPFI03.5T
SPFI	20	50	SPFI020	SPFI020.L

Web Resources

Downloadable CAD drawings and other technical information:
littelfuse.com/spfi

Recommended Crimping Tool

T&B Sta-Kon ERG4002 or equivalent
Weidmüller HTN 21 or equivalent

Dimensions mm (in)

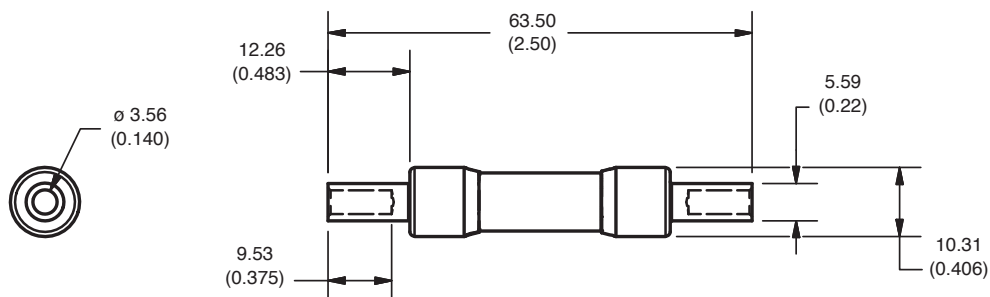

LFJ1000 SERIES SOLAR FUSE BLOCK

1000 VDC • Clip-to-Box • Stud-to-Stud • Clip-to-Stud

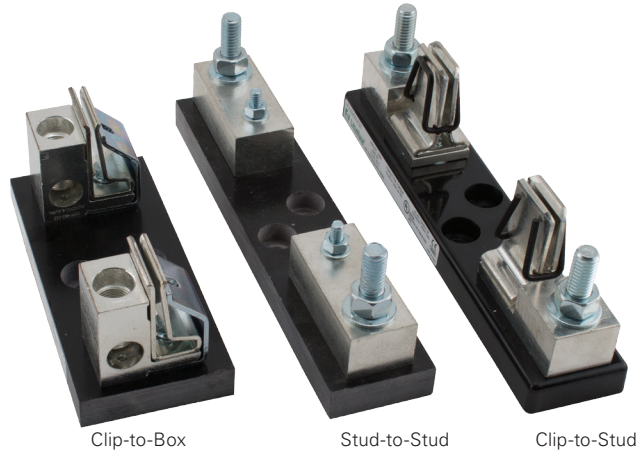

Clip-to-Box

Stud-to-Stud

Clip-to-Stud



Description

The LFJ1000 series fuse block is specifically designed for the Littelfuse SPFJ 1000 V Solar Fuse. It meets UL electrical requirements, is available in multiple amperages, and comes in a variety of fuse mounting and termination configurations; fuse clip to box lug, fuse stud to wire stud and fuse clip to wire stud.

Features/Benefits

- Narrow width increases space savings
- Range of amperages to match all SPFJ fuse options
- Box Lug termination style accommodates a wide range of cable sizes
- Stud-mounted option increases convenience
- Approval for use with copper or aluminum lugs allowing for design flexibility

Ordering Information

(Clip-to-Box Lug 1000 V)

AMPERAGE	ORDERING NUMBER	INTERRUPT RATING	WIRE RANGE STANDARD (METRIC)	WIRE TYPE		RECOMMENDED TORQUE
200	LFJ102001C	20 kA	250 kcmil - #6 (127mm ² - 16mm ²)	Cu/Al	Solid/ Stranded	275 in-lb (31.1 N-m)
400	LFJ104001C	10 kA	350 kcmil - 1/0 (177mm ² - 55mm ²)			275 in-lb (31.1 N-m)
450	LFJ104501C	20 kA	500 kcmil - #4 (253mm ² - 25mm ²)			375 in-lb (42.4 N-m)

(Stud-to-Stud 1000 V)

AMPERAGE	ORDERING NUMBER	INTERRUPT RATING	RECOMMENDED TORQUE		MAX. BUSBAR THICKNESS	RECOMMENDED BASE TORQUE	
			FUSE	TERMINAL		BOLT SIZE	TORQUE
200	LFJ102001STST	20 kA	65 in-lb (7.3 N-m)	200 in-lb (22.6 N-m)	.774" (19.66 mm)	1/4" 5/16"	30-40 in-lb 40-50 in-lb
400	LFJ104001STST	10 kA	170 in-lb (19.2 N-m)	200 in-lb (22.6 N-m)	.555" (14.10 mm)		
450	LFJ104501STST	20 kA	300 in-lb (33.9 N-m)	300 in-lb (33.9 N-m)	.570" (14.18 mm)		

(Clip-to-Stud 1000 V)

AMPERAGE	ORDERING NUMBER	INTERRUPT RATING	RECOMMENDED TORQUE	MAX. BUSBAR THICKNESS	RECOMMENDED BASE TORQUE	
			TERMINAL		BOLT SIZE	TORQUE
200	LFJ102001CST	20 kA	200 in-lb (22.6 N-m)	.774" (19.66 mm)	1/4" 5/16"	30-40 in-lb 40-50 in-lb
400	LFJ104001CST	10 kA	200 in-lb (22.6 N-m)	.555" (14.10 mm)		
450	LFJ104501CST	20 kA	300 in-lb (33.9 N-m)	.570" (14.18 mm)		

Specifications

Voltage Ratings	1000 VDC
Ampere Ratings	200, 400, 450 A
Flammability Rating	UL94 V-0
Termination Type	Box Lug or Stud Mount
Base Temp Rating	130° C
Approvals	UL 4248-18 Listed File: E345481 Vol. 1 RoHS Compliant
Environmental	

Recommended Fuses

SPFJ Solar Series

Web Resources

Sample requests, downloadable CAD drawings, dimensions and other technical information:

Littelfuse.com/LFJ1000

For a comprehensive overview of solar market solutions, visit:

Littelfuse.com/solar

SPFR SERIES AND SPFRHV SERIES

SPFR 1000 VDC Solar Fuse



Description

The SPFR series was designed to meet the growing needs of the solar industry with higher amperage and voltage requirements. It was developed specifically for solar applications, ranging from 250 A to 400 A.

Applications

- Solar Inverters
- High-amperage combiner boxes

Features/Benefits

- DC Voltage rating meets European system requirements and North American utility scale requirements
- Multiple amperage ratings
- UL Class H Dimensions
- Full Range Protection

Specifications

- Voltage Rating:** 1000 VDC
- Ampere Rating:** 250, 300, 350, 400
- Interrupting Rating:** 10,000 A; Time Constant less than 1 ms
- Fuse Type:** Fast-acting
- Approvals:** UL 248 Recognized (File: 71611)
CSA Certified (File: 29862)

Ordering Information

AMPERAGE	PART NUMBER	ORDERING NUMBER
250	SPFR 250	SPFR250.X
300	SPFR 300	SPFR300.X
350	SPFR 350	SPFR350.X
400	SPFR 400	SPFR400.X

Web Resources

Downloadable CAD drawings and other technical information:
Littelfuse.com/spfr

Dimensions mm (inches)

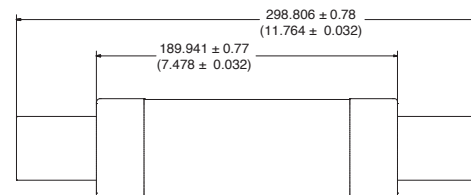

SPFRHV 1000 VDC Fuse Block



Description

The Littelfuse SPFRHV fuse block is designed to hold Littelfuse high amperage (250-400 A) SPFR fuses.

Specifications

- Voltage Rating:** 1000 VDC
- Ampere Rating:** 250 - 400 A
- Approvals:** UL 4248 Recognized (File: E14721)
CSA (File: 29862)
- Environmental:** RoHS Compliant

Ordering Information

ORDERING NUMBER	AMPERAGE
SPFRHV4001ST	250 - 400

Web Resources

Downloadable CAD drawings and other technical information:
Littelfuse.com/spfrhv

Dimensions mm (inches)

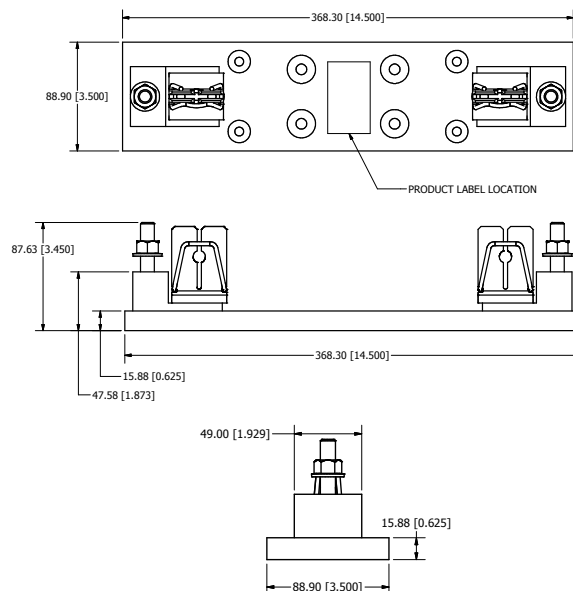

LPHV POWR-SAFE FUSE HOLDERS

1000 VDC

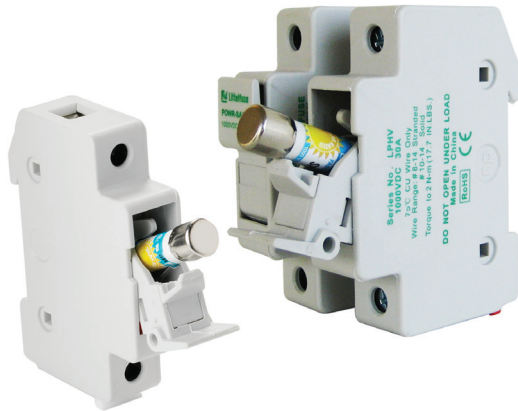

Specifications

Voltage Rating	1000 VDC
Amperage Rating	30 A
SCCR Rating	20 kA
Power Dissipation	4 W Maximum
Fuse Type	10 X 38 mm up to 1000 VDC
Material	Thermoplastic
Flammability Rating	UL94 V-0
Approval	Self-certified 1000 VDC IEC 60269-2, -4, -6
Environmental	RoHS compliant, Lead (Pb) Free

Multi-Pole Assembly Kit

Kits are used to create multi-pole holders from 1-pole LPHV fuse holders. Please contact factory for more information.

ORDERING NUMBER	DESCRIPTION
CYHP001	20 Connector Pincers & 10 handle Pins
CYHP002	Connector Pincer Only
CYHP003	Handle Pin Only

Web Resources

Sample requests, downloadable CAD drawings and other technical information: Littelfuse.com/lphv

More information about solar applications: Littelfuse.com/solar

Recommended Fuses

10x38 mm 1000 VDC Fuses
SPF 1000 V Series
FLU 1000 V Series



Description

The Littelfuse LPHV fuse holder is designed to house 1000 V fuses. It is not designed for load break but is ideal for isolating photovoltaic module strings for maintenance and meets UL requirements for 1000 V solar fuse protection

Features/Benefits

- Touch-safe design offers protection when replacing fuses
- Compact design
- 35 mm DIN Rail Mountable
- Available in 1-, 2-, 3- and 4-pole configurations
- No fuse pullers or tools required for fuse removal

Ordering Information

SERIES	POLES	CATALOG NUMBER	ORDERING NUMBER	TERMINAL TYPE	WIRE TYPE	WIRE RANGE	TERMINAL TORQUE	ROHS
LPHV	1	LPHV001	LPHV0001Z	Pressure Plate	75° C or 90° C CU Only	Stranded / [Solid]	17.7 in-lbs (2 N-m)	•
LPHV	2	LPHV002	LPHV0002Z					•
LPHV	3	LPHV003	LPHV0003Z					•
LPHV	4	LPHV004	LPHV0004Z					•

Dimensions Inches (mm)

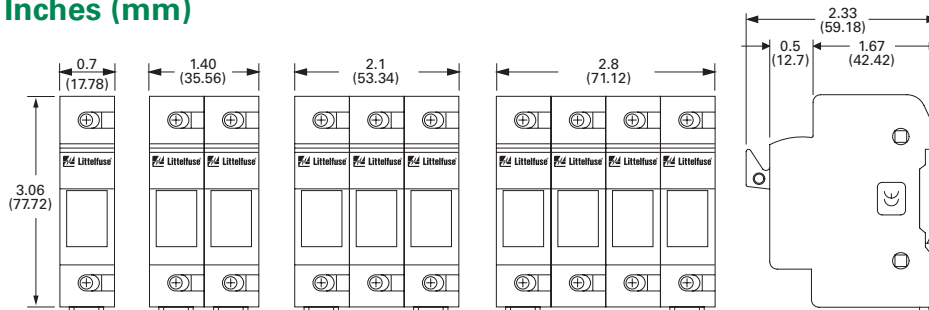

BUS BAR SYSTEM

POWR-BAR Distribution

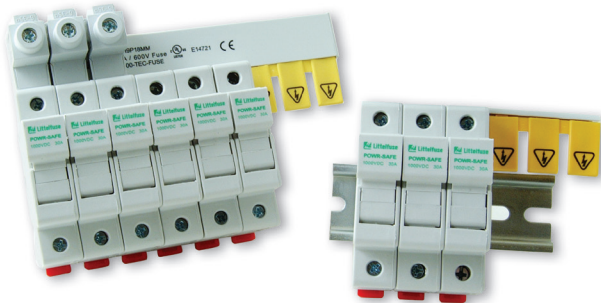

Description

A key objective for panel designers is safe distribution of power to multiple fuse holders in a compact design. The Littelfuse UL 508 Listed bus bar system eliminates most wire terminations in a timesaving package. A power distribution block and associated conductors are no longer needed to feed multiple POWR-safe fuse holders.

Features/Benefits

- Touch-safe design offers protection when replacing fuses
- Compact design
- 35mm DIN-rail mountable
- Available in one and three phase configurations
- Can be cut down to optimal size

Recommended Fuse Holders

Littelfuse LFPSM / LFPSC / LPSM / LPSC (600 V)
Littelfuse LPHV (1000 V)

Web Resources

Download technical documents: Littelfuse.com/busbar

Specifications

Voltage Ratings 600 Vac/dc
1000 Vdc*

Current Ratings

CROSS SECTION (mm ²)	18 mm ²	25 mm ²
END FED	80 A	100 A
CENTER FED	160 A	200 A

SCCR 10 kA, 100 kA[†]
Conductor Copper
Pitch 17.8 mm
Approvals UL 508 Listed (File E328654)
Environmental RoHS Compliant
 Lead (Pb) free

*1 Phase 18 mm² rated 1000 Vdc up to 160 A when center fed
 1 Phase 25 mm² rated 1000 Vdc up to 200 A when center fed
[†]When protected directly upstream by Class J 175 amperes max (18 mm² bus bar) and Class J 200 amperes max (25 mm² bus bar).

Ordering Information

1 PHASE, 18 mm ²			LENGTH (mm)	1 PHASE, 25 mm ²			LENGTH (mm)
ORDERING NUMBER	POLES			ORDERING NUMBER	POLES		
1PH3P18mm	3		50	1PH3P25mm	3		50
1PH4P18mm	4		79	1PH4P25mm	4		79
1PH6P18mm	6		104	1PH6P25mm	6		104
1PH9P18mm	9		155	1PH9P25mm	9		155
1PH12P18mm	12		208	1PH12P25mm	12		208
1PH15P18mm	15		270	1PH15P25mm	15		270
1PH57P18mm	57		1009	1PH57P25mm	57		1009

3 PHASE, 18 mm ²			LENGTH (mm)	3 PHASE, 25 mm ²			LENGTH (mm)
ORDERING NUMBER	POLES			ORDERING NUMBER	POLES		
3PH6P18mm	6		104	3PH6P25mm	6		104
3PH9P18mm	6		158	3PH9P25mm	9		158
3PH12P18mm	12		214	3PH12P25mm	12		214
3PH15P18mm	15		266	3PH15P25mm	15		266
3PH57P18mm	57		1009	3PH57P25mm	57		1009

Endcaps are standard with all 3 phase configurations except 57-pole. Endcaps are not needed for the 1 phase configurations from the factory or if the copper bus is trimmed per the supplied instructions. Power feed lugs and protective covers are extra.

Accessories

Power Feed Lug

PART NUMBER	AMP RATING	VOLTAGE (AC / DC)	WIRE RANGE	WIRE TYPE	TORQUE
BB17	115	1000	#10 - 1/0 AWG	CU	50 lb-in
BB18	115	1000	#10 - 1/0 AWG	CU	50 lb-in
BB19	115	1000	#10 - 1/0 AWG	CU	50 lb-in
BB20	115	1000	#10 - 1/0 AWG	CU	50 lb-in

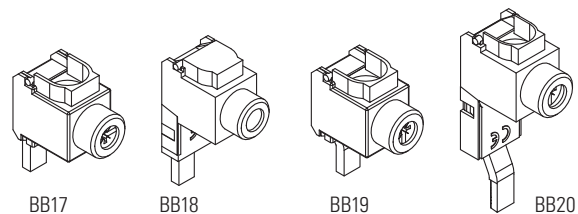

Endcaps

PART NUMBER	PHASE	QUANTITY
EDCP42	Single	50
EDCP7	Three	50

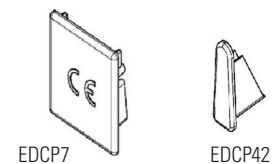

Pole Protective Covers

PART NUMBER	QUANTITY
CTPT5	5

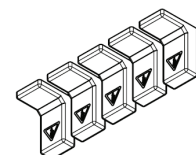

LFPSC / LFPSM DEAD-FRONT FUSE HOLDERS

600 V • 10x38mm • Class CC • Midget



Description

Littelfuse LFPSC Class CC and LFPSM 10x38mm dead-front holders feature optional LED indication, DIN rail mounts and a small space saving design. These high SCCR rated holders provide optimum touch-safe protection to personnel and have a large clamping range with dual wire rated terminals.

Features

- Indicating and non-indicating options available
- Dual LED indication distinguishes polarity in DC applications
- Small compact design offers ultimate flexibility
- 35 mm DIN-Rail Mountable
- 1-, 2-, 3- and 4-pole configurations
- Easy installation and fuse removal with no additional pullers or tools required

Web Resources

Download technical documents at:

littelfuse.com/lfpcc
littelfuse.com/lfpvh

Recommended Fuses

Class CC Holders:

CCMR, KLDR, KLKR

Midget Holders:

BLF, BLN, BLS, FLM,
FLQ, KLK, KLKD, KLO

Terminal Information

TERMINAL TYPE	WIRE TYPE	NUMBER OF WIRES	WIRE SIZE	TORQUE
Pressure Plate	75" Max CU Only Stranded*	1	18-8 AWG (.75-25 mm ²)	18-22 lb-in (2-2.5 N-m)
		1	6-4 AWG	22-26 lb-in
		2†	18-6 AWG (.75-10 mm ²)	18-22 lb-in (2-2.5 N-m)

*Contact Tech-Line (800-TEC-FUSE) for other wire types.

†Must be the same cross-sectioned size

Specifications

Voltage Rating

UL: 600 Vac/dc
IEC: 690 Vac (LFPSM)

Ampere Rating

UL: 30 A
IEC: 32 A (LFPSM)

SCCR Rating

200 kA (Class CC)
100 kA (Midget)

Power Acceptance

3W Maximum

Indication Voltage Range

110-690 Vac/dc

Terminal Type

Pressure Plate

Material

Thermoplastic

Flammability Rating

UL94 V-0, self-extinguishing

Approvals

UL Listed (File: E14721)

CSA Certified

IEC 60269 (LFPSM)

RoHS compliant, Lead (Pb) free

Environmental

Dimensions mm (inches)

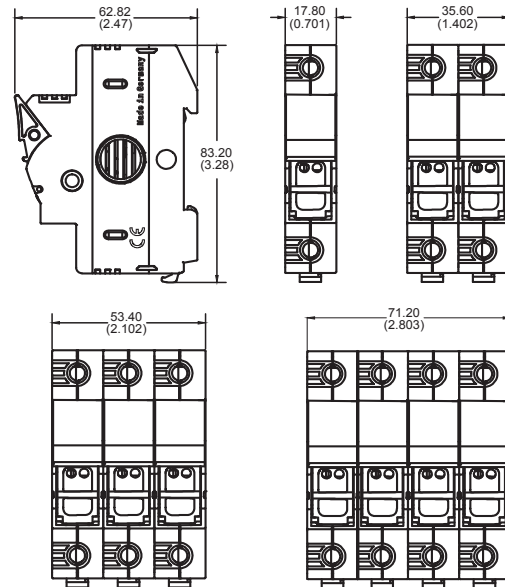

Multi-Pole Assembly Kits

POLES	PINCER QTY.	PIN QTY.	ASSEMBLY SETS	ORDERING NUMBER
2	20	10	10 pack	LFPHV2PAK
3	40	10	10 pack	LFPHV3PAK



Connector Pincer



Handle Pin

Ordering Information (LFPSC Class CC and LFPSM Midget)

VOLTAGE	AMPERE	SCCR Rating	POLES	FUSE TYPE	SERIES	NON-INDICATING		INDICATING		PACK QUANTITY
						CATALOG NUM.	ORDERING NUM.	CATALOG NUM.	ORDERING NUM.	
600 Vac/dc	—	30 A	—	200 kA	Class CC	LFPSM	LFPSM0001Z	LFPSM0001ID	LFPSM0001ZXID	12
						LFPSM	LFPSM0002Z	LFPSM0002ID	LFPSM0002ZXID	6
						LFPSM	LFPSM0003Z	LFPSM0003ID	LFPSM0003ZXID	4
						LFPSM	LFPSM0004Z	LFPSM0004ID	LFPSM0004ZXID	3
600 Vac/dc	690 Vac	30 A	32 A	100 kA	10x38mm (Midget)	LFPSM	LFPSM0001Z	LFPSM0001ID	LFPSM0001ZXID	12
						LFPSM	LFPSM0002Z	LFPSM0002ID	LFPSM0002ZXID	6
						LFPSM	LFPSM0003Z	LFPSM0003ID	LFPSM0003ZXID	4
						LFPSM	LFPSM0004Z	LFPSM0004ID	LFPSM0004ZXID	3

KLKD SERIES 10x38 FUSES

600 Vac/dc • 1/10-30 A • Fast Acting



Description

The KLKD fuse series is fast-acting with a high DC voltage rating. This family of Midget style fuses (10 x 38 mm) is used in solar combiner boxes and in circuits with DC fault currents up to 50,000 amperes. KLKD fuses are available in standard and board-mount configurations.

In addition, the KLKD series has been designed to meet both the UL and IEC photovoltaic fuse standards.

Littelfuse offers a wide range of ampere ratings to match specific requirements in a variety of applications.

Features/Benefits

- Designed to UL and IEC photovoltaic specifications
- 1/10 - 30 A ratings available
- 50,000 A Interrupting Rating
- Available in ferrule or PCB mount options
- 1-5 A meets UL1741 GFDI requirements

Applications

- Combiner boxes and Inverters
- Power supplies
- Desktop meters

Dimensions Inches (mm)

Ferrule Version

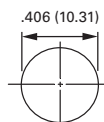
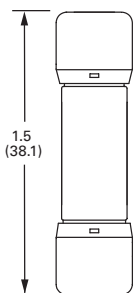

PCB 1-Tab

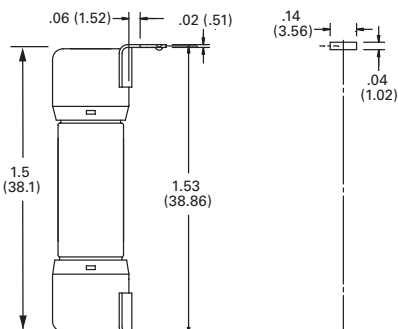

MOUNTING HOLE
DETAIL

Specifications

Voltage Rating:	600 Vac/Vdc
Amperage Rating:	1/10, 1/8, 2/10, 1/4, 3/10, 1/2, 3/4, 1, 1 1/2, 2, 2 1/2, 3, 3 1/2, 4, 5, 6, 7, 8, 9, 10, 12, 15, 20, 25, 30
Interrupting Ratings:	AC: 100 kA 200 kA Littelfuse self-certified DC: 1/10-30: 10 kA (UL 2579) 1/10-30: 50 kA (UL 248-14)
Material:	Body: Melamine / Caps: Copper Alloy
Operating Temperature:	See Rerating Curve
Approvals:	UL 2579 Listed (File: E339112) IEC 60269-6 (2-25 A) VDE Certified (No. 40033094) UL 248-14 Listed (File: E10480) CSA Certified Ferrule only (File: LR29862) RoHS Compliant
Environmental:	Mexico
Country of Origin:	Mexico

Part Numbering System

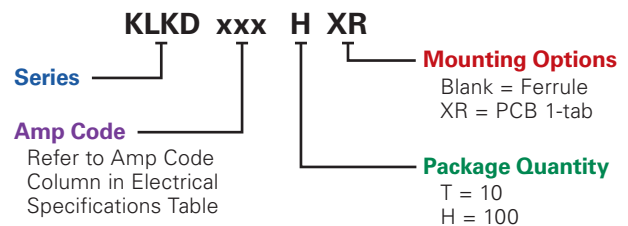

SERIES	AMP	PACKAGE QUANTITY	MOUNTING METHOD	CATALOG NUMBER	ORDERING NUMBER
KLKD	1/8	10	FERRULE	KLKD.125	KLKD.125T
KLKD	5	100	FERRULE	KLKD005	KLKD005.H
KLKD	15	10	PCB 1-TAB	KLKD015R	KLKD015.TXR

Recommended Fuse Holders

Littelfuse LPSM and LFPSM Dead-Front Series
Littelfuse L60030M Open-Face Series

Web Resources

Download CAD drawings and other technical information:
littelfuse.com/klkd

POWR-BLOKS™

600 V • Distribution Blocks • Splicer Blocks



Description

POWR-BLOKS™ power distribution blocks offer a safe, convenient way of splicing cables, providing a fixed junction tap-off point or splitting primary power into secondary circuits. Lx2xxx-DIN series offers integral DIN-Rail mount and an optional hinged safety cover.

Optional power distribution block covers provide protection against accidental shorting between poles caused by loose wires, tools, or other conductive material. They also protect personnel from accidentally contacting energized connectors. To order protective covers, match the number of poles for the block to the cover.

Applications

- Solar string
- Array combiner boxes
- Inverters

Ampere Ratings

The ampere rating per pole for the power distribution blocks is based on the line ampacity of 75° C insulated conductors per NEC® Table 310.16. If 60° C insulated conductors are used, load must not exceed the ampacity of 60° C conductors. Use of conductors rated in excess of 75° C is permitted (for example 90° C), however, load must not exceed the ampacity of 75° C conductors.

Connectors

Box lug connectors are designed for use with a single, solid or class B or C stranded conductor. Use of more than one conductor per connector opening or use of extra-flexible, fine-stranded conductors, such as welding cable, voids the UL Listing and may cause overheating. Manufacturers of cable terminations can furnish crimp-on sleeves for fine stranded conductors which permit these conductors to be used with box lugs.

Specifications

Voltage Rating	600 V
Current Rating	Based on NEC Table 310.16, using 75°C copper wire
Material	Phenolic rated at 150°C and Thermoplastic rated at 125°C (LD1400 and LS1300 series only)
Connector	Standard: Highly conductive aluminum, tin plated Copper: Highly conductive copper, tin plated
Flammability Rating	UL94 V-0
Approvals	UL Recognized - LD/LS Series (File: E171395) LFD/LFS Series (File: E309688) CSA Certified - LD/LS Series (File: LR700111) LFD/LFS Series (File: 007316_0_000)
Environmental	RoHS compliant, Lead (Pb) free

Web Resources

For a detailed list of part numbers, ordering information, dimensions, and CAD drawings, visit:

Littelfuse.com/powrbloks

Clear Plastic Covers



Hinged Plastic Covers



3

IGBT MODULE, HALF-BRIDGE

600 / 1200 V • S Package • D Package • WB Package



Description

Half-Bridge Circuit IGBT Modules offer the high efficiency and fast switching speeds of modern IGBT technology in a robust and flexible format. Used for power control applications, Littelfuse offers its first IGBT modules for flexible and efficient motor control and inverter applications.

Features

- Ultra Low Loss
- High Ruggedness
- High Short Circuit Capability
- Positive Temperature Coefficient
- With Fast Free-Wheeling Diodes

Benefits

- High efficiency and switching speed
- High reliability in demanding applications
- Reduced protection needs
- Easily paralleled
- Integrated solution in compact module package

Applications

- AC Motor Control
- Inverter
- Motion / Servo Control
- Power Supplies
- Photovoltaic / Fuel Cell

Web Resources

Download the complete datasheet and other technical information: littelfuse.com

Dimensions Inches (mm)

S Package Type

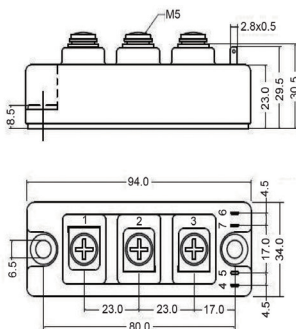

D Package Type

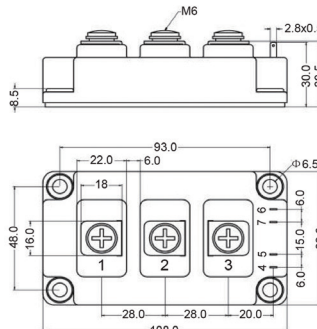

WB Package Type

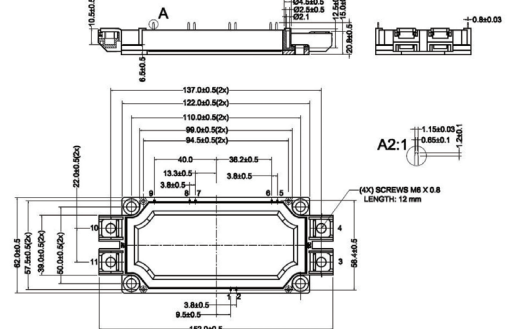

Specifications

Voltage Rating	600 / 1200 V
Amperage Rating	S Package: 75, 100, 150, 200 D Package: 100, 150, 200, 300, 400 WB Package: 225, 300, 450, 600
Circuit Type	Half-Bridge
Approvals	UL Listed (File: E71639)
Environmental	RoHS Compliant

Part Numbering System

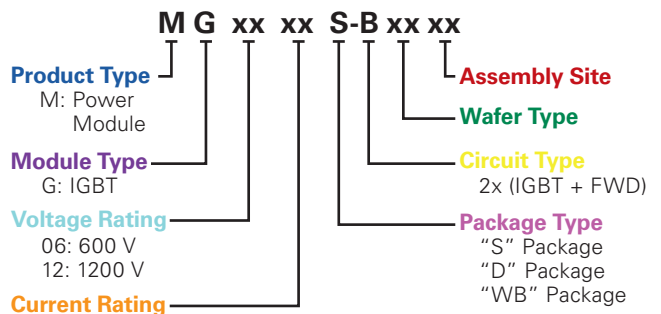

Ordering Information

ORDERING NUMBER	VOLT	AMPS	PACKAGE TYPE	MOUNTING METHOD	M.O.Q.
MG1250S-BA1MM	1200	50	S	SCREW	100
MG12100S-BN2MM	1200	100	S	SCREW	100
MG12150S-BN2MM	1200	150	S	SCREW	100
MG1275S-BA1MM	1200	75	S	SCREW	100
MG06100S-BN4MM	600	100	S	SCREW	100
MG06150S-BN4MM	600	150	S	SCREW	100
MG06300D-BN4MM	600	300	D	SCREW	60
MG06400D-BN4MM	600	400	D	SCREW	60
MG12200D-BA1MM	1200	200	D	SCREW	60
MG12300D-BA1MM	1200	300	D	SCREW	60
MG12300D-BN3MM	1200	300	D	SCREW	60
MG12400D-BN2MM	1200	400	D	SCREW	60
MG06600WB-BN4MM	600	600	WB	PRESS FIT	60
MG12225WB-BN2MM	1200	225	WB	PRESS FIT	60
MG12300WB-BN2MM	1200	300	WB	PRESS FIT	60
MG12450WB-BN2MM	1200	450	WB	PRESS FIT	60

TVS (TRANSIENT VOLTAGE SUPPRESSION) DIODES



What Are Voltage Transients?

Voltage transients are unwanted short duration surges of electrical energy. They may result from the sudden release of previously stored energy, and can come from internal and external sources. If the voltage magnitude of the transient is large enough, circuit component damage or malfunction of the circuit may result.

Transients can occur either repeatedly or as random impulses. Repeatable transients are frequently caused by the operation of other system components, such as motors, generators or the switching of reactive circuit components. Random transients, are often caused by lightning, electrostatic discharge (ESD), and other outdoor environment events.

SOURCE	VOLTAGE	CURRENT	RISE-TIME	DURATION
Lightning	25 kV	20 kA	10 μ s	50 ms
Load Switching	600 V	500 A	50 μ s	500 ms
Electromagnetic Pulse (EMP)	1 kV	300 kV	20 ns	1 ms
Electrostatic Discharge (ESD)	15 kV	30 A	1–5 ns	100 ns

TVS and Solar Inverter Protection

Integration of Transient Voltage Suppression (TVS) components within solar system designs help to prevent the damaging effects of transient events and assure compliance to safety and reliability standards. Solar power inverters are vulnerable to transient voltage effects and its direct connection to other system components allows transient voltage transfer. For example:

- Lightning-induced transient events may pass through the solar array and outdoor cabling to the inverter.
- Transients originating from the outside utility power grid may pass through the main circuit panel and cabling to the inverter.
- Startup of motorized equipment enable vulnerabilities produced by repeat load changes.
- Electrostatic discharge events generated internal and external to the system may pass between the inverter and sensitive electronic control equipment.

It is important to build surge withstand ability in the inverter and at locations before damaging transients may reach sensitive equipment.

Transient Voltage Suppression (TVS) Diodes

TVS Diodes are used to protect semiconductor components from high-voltage transients. Their p-n junctions have a larger cross-sectional area than those of a normal diode, allowing them to conduct large currents to ground without sustaining damage. Littelfuse supplies TVS Diodes with peak power ratings from 200 W to 30 kW, and reverse standoff voltages from 5 V to 512 V. For more information visit Littelfuse.com/tvsdiodes

SERIES NAME	PHOTO	PACKAGE TYPE	REVERSE STANDOFF VOLTAGE (V _R)	PEAK PULSE POWER RANGE (P _{pp} 10/1000 μ s)	PEAK PULSE CURRENT (I _{pp} 8/20 μ s)	OPERATING TEMPERATURE	HF	ROHS	
SURFACE MOUNT - STANDARD APPLICATION (200-5000 W)									
SMF		SOD-123	5.0-85	200 W	–	-67° to +302° F (-55° to +150° C)	•	•	
SMAJ		DO-214AC	5.0-440	400 W	–		•	•	
P4SMA		DO-214AC	5.8-468	400 W	–		•	•	
SMA6J		DO-214AC	5.0-12	600 W	–		•	•	
SMA6L		DO-221AC	5.0-85	600 W	–		•	•	
SACB		DO-214AA	5.0-50	500 W	–		•	•	
SMBJ		DO-214AA	5.0-440	600 W	–		•	•	
P6SMB		DO-214AA	5.8-468	600 W	–		•	•	
1KSMB		DO-214AA	5.8-153	1000 W	–		•	•	
SMCJ		DO-214AB	5.0-440	1500 W	–		•	•	
1.5SMC		DO-214AB	5.8-468	1500 W	–		•	•	
4.0SDJ		DO-214AB	24.0	4000W	–		•	•	
SMDJ		DO-214AB	5.0-220	3000 W	–		•	•	
5.0SMDJ		DO-214AB	12-170	5000 W	–		•	•	
AXIAL LEADED - STANDARD APPLICATION (400-5000 W)									
P4KE		DO-41	5.8-468	400 W	–	-67° to +347° F (-55° to +175° C)	•	•	
SA		DO-15	5.0-180	500 W	–		•	•	
SAC		DO-15	5.0-50	500 W	–		•	•	
P6KE		DO-15	5.8-512	600 W	–		•	•	
1.5KE		DO-201	5.8-512	1500 W	–		•	•	
LCE		DO-201	6.5-90	1500 W	–		•	•	
3KP		P600	5.0-220	3000 W	–		•	•	
5KP		P600	5.0-250	5000 W	–		•	•	
AXIAL LEADED - HIGH POWER (15000-30000 W; 1-15 kA)									
15KPA		P600	17-280	15000 W	–	-67° to +347° F (-55° to +175° C)	•	•	
20KPA		P600	20-300	20000 W	–		•	•	
30KPA		P600	28-288	30000 W	–		•	•	
AK1		Radial Lead	76	–	1000 A		-67° to +302° F (-55° to +150° C)	•	•
AK3		Radial Lead	15-430	–	3000 A			•	•
AK6		Radial Lead	30-430	–	6000 A			•	•
AK10		Radial Lead	15-530	–	10000 A			•	•
AK15		Radial Lead	58-76	–	15000 A			•	•

OVERVOLTAGE SUPPRESSION VARISTORS



Protection Application and Needs

Description:

Microprocessor-controlled inverter with the AC output synchronized to the AC grid stores energy in utility company and maximizes PV array energy output.

Threats:

- Power surges on AC or DC Input and AC Output
- ESD threats through the communication network

Solutions:

1. **AC Input:** Fuse / MOV / GDT
2. **DC Input:** DC-rated fuse / Unidirectional TVS / MOV
3. **AC Output:** Fuse / TVS / MOV
4. **Local Ethernet:** MLV / SPA
5. **Outside Ethernet:** SEP series SIDACTor® device

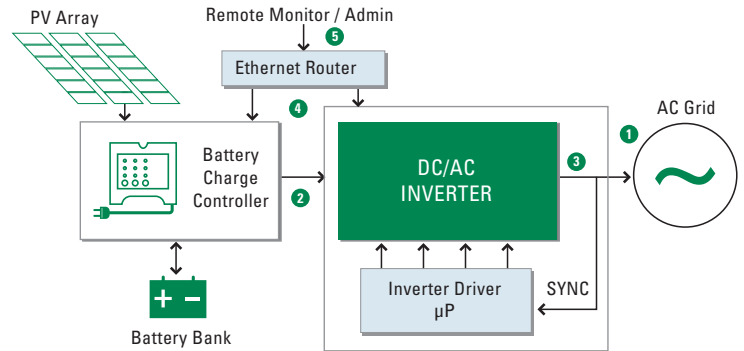

Example: Hybrid Solar Inverter Configuration

Varistor Products

Varistors possess characteristics that divert transient currents away from sensitive components. Littelfuse offers two types: miniature surface mount Multi-Layer Varistors (MLVs) for small electronics applications and Metal Oxide Varistors (MOVs) for higher energy applications. For more information visit Littelfuse.com/varistor

SERIES NAME	PHOTO	OPERATING Vac RANGE	OPERATING Vdc RANGE	PEAK CURRENT RANGE ² (A)	PEAK ENERGY RANGE (J)	OPERATING TEMPERATURE	MOUNT/ FORM FACTOR	DISC SIZE	AGENCY APPROVALS							
									UR	CSA	VDE	CECC	ROHS	HF		
SURFACE MOUNT MLV / MOV																
ML		2.7-107	5.5-120	4-500	0.02-2.5	-55 to +125°C	Surface Mount	Not Applicable						•	•	
CH		14-275	18-369	100-400	1.0-8.0	-55 to +125°C	Surface Mount	Not Applicable	•					•		
SM7		115-510	369-675	1200	10-40	-55 to +85°C	Surface Mount	Not Applicable	•					•	•	
SM20		20-320	26	2000-6500	20-150		Surface Mount	Not Applicable	•					•	•	
RADIAL LEADED MOV																
UltraMOV™		130-625	170-825	1750-10000	12.5-720	-55 to +85°C	Radial Leaded	7, 10, 14, 20 mm	•	•	•	•	•	•	•	
UltraMOV™ 25S		115-750	150-970	22000	230-890			25 mm	•	•	•	•	•	•	•	•
C-III		130-660	—	3500-9000	40-530			10, 14, 20 mm	•	•	•	•	•	•	•	•
LA		130-1000	175-1200	1200-6500	11-360			7, 10, 14, 20 mm	•	•	•	•	•	•	•	•
ZA		4-460	5.5-615	50-6500	0.1-52			5, 7, 10, 14, 20 mm	•	•	•	•	•	•	•	•
THERMALLY PROTECTED MOV																
SMOV™ 25S		115-750	150-970	20000	170-670	-45 to +75°C	Industrial Packaged Radial Leads	25 mm	•					•		
SMOV™ 34S		115-750	150-970	40000	280-1200	-45 to +75°C	Industrial Packaged Radial Leads	34 mm	•					•		
TMOV® 25S		115-750	150-970	20000	170-670	-55 to +85°C	Radial Leaded	25 mm	•		•	•	•			
TMOV® 34S		115-750	150-970	40000	235-1050			34 mm	•		•	•	•			
TMOV®/iTMOV®		115-750	150-970	6000-10000	35-480			14, 20 mm	•		•	•	•			

SE-601 SERIES (PGR-2601)

DC Ground-Fault Monitor



Description

The SE-601 is a microprocessor-based ground-fault relay for ungrounded dc systems. It provides sensitive ground-fault protection without the problems associated with nuisance tripping. Ground-fault current is sensed using an SE-GRM Series Ground-Reference Module—a resistor network that limits ground-fault current to 25 mA. The SE-601 is used on ungrounded dc systems ranging from industrial 24-Vdc control circuits to 1000-Vdc solar and transportation systems.

Ordering Information

ORDERING NUMBER	CONTROL POWER
SE-601-OU	120/240 Vac/Vdc
SE-601-OD	12/24 Vdc
SE-601-OT	48 Vdc

ACCESSORIES	REQUIREMENT
SE-GRM SERIES	Required
PGA-0500	Optional
PMA-55	Optional
PMA-60	Optional

Note: For optional conformal coating please consult factory.

Simplified Circuit Diagram

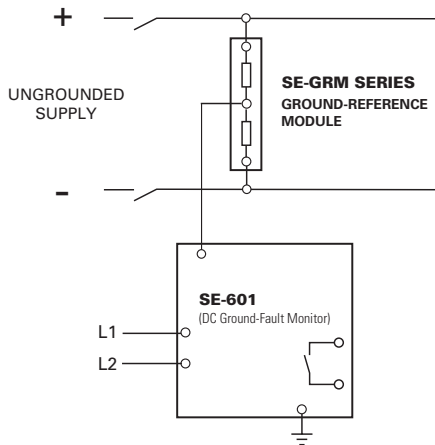

Features & Benefits

FEATURES	BENEFITS
Adjustable pickup (1-20 mA)	Ten settings provide a wide range of low-level protection
Adjustable time delay (50 ms-2.5 s)	Adjustable trip delay allows quick protection or delayed response
Output contacts	Form A and Form B output contacts for operation of separate annunciation and trip circuits
Analog output (0-5 V)	Provides means for connecting to a meter (PGA-0500) or a control system
Non-volatile trip Memory	Retains trip state when de-energized to simplify troubleshooting
Selectable contact operating mode	Selectable fail-safe or non-fail-safe operating modes allow connection to shunt or undervoltage breaker coil
Microprocessor based	No calibration required saves on maintenance cost

Specifications

IEEE Device Numbers	DC Overcurrent Relay (76G)
Input Voltage	See ordering information
Dimensions	H 75 mm (3.0"); W 55 mm (2.2"); D 115 mm (4.5")
Trip Level Settings	1-20 mA
Trip Time Settings	0.05-2.5 s
Output Contacts	Isolated Form A and Form B
Contact Operating Mode	Selectable fail-safe or non-fail-safe
Test Button	Local
Reset Button	Local and remote
Analog Output	0-5 V
Conformally Coated	Consult factory
Approvals	CSA Certified, UL Listed (E340889), CE (European Union), C-Tick (Australian)
Warranty	5 years
Mounting	DIN, Surface (standard) Panel (with PMA-55 or PMA-60 adapter)

Accessories



SE-GRM Series Ground-Reference Module
Required accessory, used to connect the SE-601 DC Ground-Fault Monitor to the DC bus.



PGA-0500 Analog % Current Meter
Optional panel-mounted analog meter displays ground-fault current as a percentage of 22 mA.

EL731 SERIES

AC/DC Sensitive Earth-Leakage Relay



Description

The EL731 is a microprocessor-based AC/DC Sensitive Earth-Leakage Relay that offers complete coverage for all frequencies from 0-6,000 Hz. Two CTs are required for the entire frequency range, or one CT can be used for only low- or high-frequency detection. An RTD/PTC sensor input allows over-temperature protection. The EL731 offers metering capabilities, password-protected alarm and trip settings and optional network communications. It is used to add low-level ground-fault protection to variable-speed drives, and to DC currents.

Ordering Information

ORDERING NUMBER	CONTROL POWER	COMMUNICATIONS
EL731-00-X0	120/240 Vac/Vdc	None
EL731-01-X0	120/240 Vac/Vdc	DeviceNet™
EL731-02-X0	120/240 Vac/Vdc	Profibus®
EL731-03-X0	120/240 Vac/Vdc	EtherNet/IP™
EL731-04-X0	120/240 Vac/Vdc	Modbus® TCP
EL731-10-X0	48 Vdc & 24 Vac	None
EL731-11-X0	48 Vdc & 24 Vac	DeviceNet™
EL731-12-X0	48 Vdc & 24 Vac	Profibus®
EL731-13-X0	48 Vdc & 24 Vac	EtherNet/IP™
EL731-14-X0	48 Vdc & 24 Vac	Modbus® TCP
EL731-20-X0	24 Vdc	None
EL731-21-X0	24 Vdc	DeviceNet™
EL731-22-X0	24 Vdc	Profibus®
EL731-23-X0	24 Vdc	EtherNet/IP™
EL731-24-X0	24 Vdc	Modbus® TCP

Note: When building a part number, replace the "X" with "1" for AS/NZS 2081:2011 Compliant product, "0" otherwise.

Features & Benefits

FEATURES	BENEFITS
Adjustable pickup (30-5,000 mA)	Adjustable trip setting provides a wide range of low-level protection and system coordination
Frequency range (0-90 Hz, 20-6,000 Hz)	Operate in either AC or DC mode or both. Use single or combined ranges. Separate metering
32-char OLED display	Earth-leakage metering, setup and programming
Local LED indication	Visual Trip, Alarm, CT connection indication
CT-Loop monitoring	Alarms when CT is not connected
Analog output (4-20 mA)	Connect to DCS. Allows connection to an optional meter (PGA-0500) or control system
Adjustable time delay	Adjustable trip delay for quick protection and system coordination
Alarm and trip settings	Detect a deteriorating condition before damage occurs
Temperature-sensor input	Drive or motor temperature protection
Output contacts	3 programmable: Operate 2 alarm and 1 trip circuit
Network communication	Optional connection to plant network
Harmonic filtering	Eliminates nuisance tripping due to harmonic noise
Microprocessor based	No required calibration saves maintenance cost
Universal power supply	Provides flexibility for numerous applications

Specifications

IEEE Device Numbers	AC ground fault (50G/N, 51G/N), DC ground fault (79G), PTC overtemperature (49), RTD temperature (38, 49)
Supply Voltage	120/240 Vac/Vdc, 24 Vdc, 48 Vdc/24 Vac
Trip Level Settings	30-5,000 mA AC and DC
Alarm Level Settings	30-5,000 mA AC and DC
Trip Delay	0.05-2 s
Output Contacts	3 Form C (programmable)
Contact Operating Mode	Fail-safe & non-fail-safe
Reset	Front panel and remote
Freq. Response, CT1	0-90 Hz
Freq. Response, CT2	20-6,000, 190-6,000, 20-90, 20-3,000 Hz; selectable
Current Transformer	EFCT-x series
CT Detection	Open & short detection
Terminals	Plug-in, wire clamping, 24 to 12 AWG (0.2-2.5 mm ²)
Communications	EtherNet/IP™, DeviceNet™, Profibus®, Modbus® TCP (optional)
Analog Output	4-20 mA (selectable 0-5 A or 0-100% trip-level setting)
Conformal Coating	Standard feature
Dimensions	H 48 mm (1.9"); W 96 mm (3.8"); D 129 mm (5.0")
Approvals	UL Listed (E340889), CSA, C-Tick (Australia)
Warranty	5 years
Mounting	Panel; Surface and DIN (with optional AC700-SMK)

SOLAR PRODUCTS BY APPLICATION

1. SPXV 1500 V – 6-30 A Fuse
2. SPXI 1500 V – 2.5-30 A In-Line Fuse
3. SPFJ 1000 V – 70-450 A Fuse
4. SPF 1000 V – 1-30 A Fuse
5. SPFI 1000 V – 2-30 A In-Line Fuse
6. KLKD 600 V – 1/10-30 A Fuse
7. IDSR & LDC 600 V Fuse and Holder
8. LFJ1000 Fuse Block for SPFJ Fuse
9. LPHV & LFPSM Touch-Safe Fuse Holder
10. Busbar for Touch-Safe Fuse Holders
11. Power Distribution Block
12. SE-601 DC Ground-Fault Relay
13. TVS Diodes / SCRs
14. Varistor Products

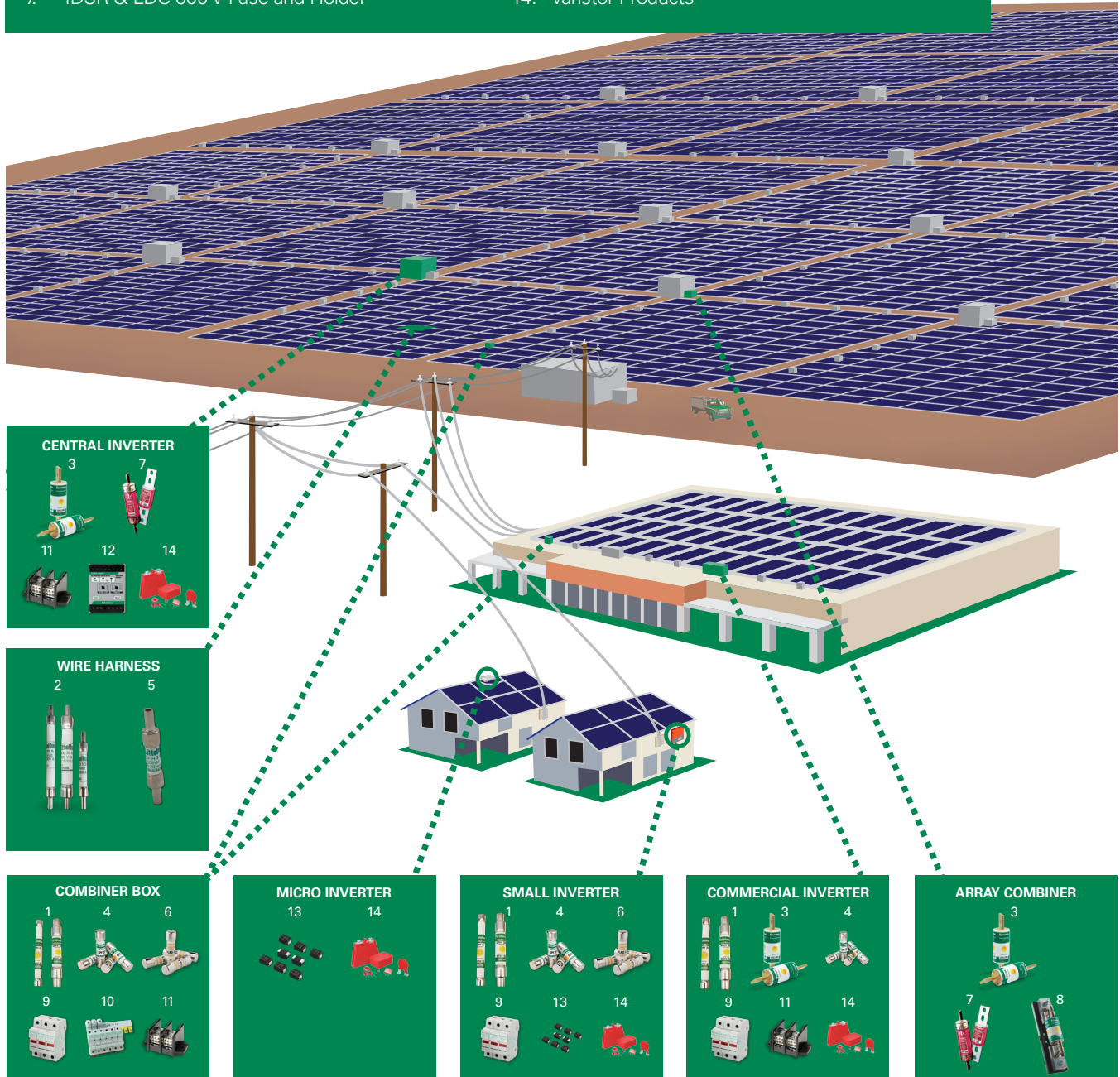

Let Us Help With Your Solar Applications

Contact our solar product experts today and visit us at Littelfuse.com/solar to find out what Littelfuse can do for you.



Corporate Headquarters

- **Littelfuse Inc.**
8755 West Higgins Road
Suite 500
Chicago, IL 60631 USA

773 628 1000
Littelfuse.com

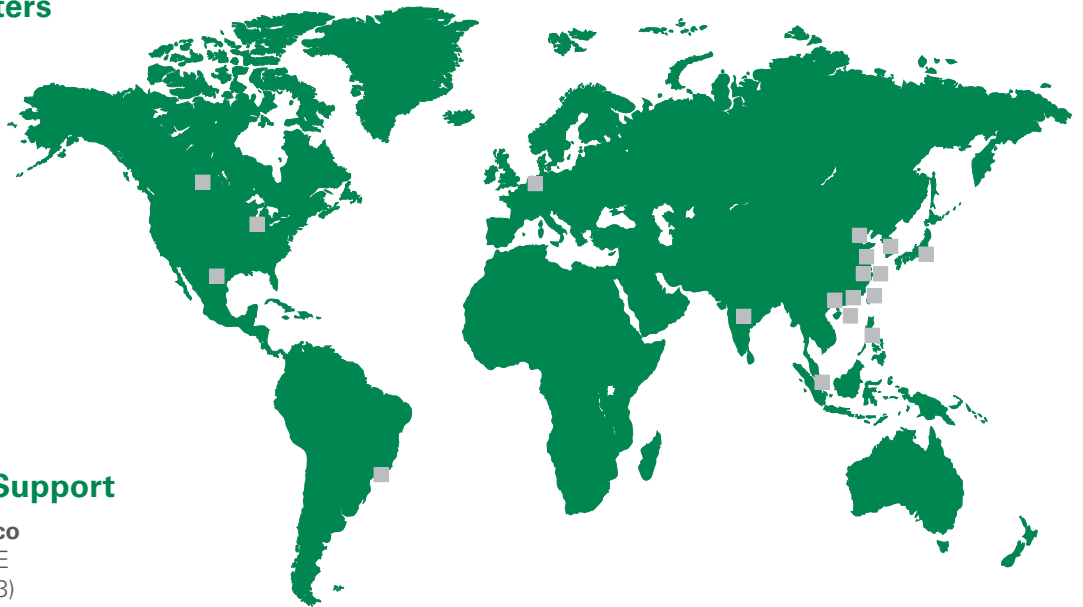

Sales and Technical Support

- **United States and Mexico**
Phone 800 TEC FUZE (800 832 3873)
Fax 800 522 7697
- **Brazil**
Phone +55 11 4427 6261
- **Canada**
Phone 306 373 5505
- **Hong Kong, China**
Phone +852 2810 5099
- **Shanghai, China**
Phone +86 21 2327 6000
- **Shenzhen, China**
Phone +86 755 8207 0760
- **Dubai**
Phone +971 4341 3660
- **Europe**
Phone +49 4244 819149
- **India**
Phone +65 6885 9185
- **Japan**
Phone +81 45 478 1088
- **Singapore**
Phone +65 6885 9188
- **South Korea**
Phone +82 2 6000 8600
- **Taiwan**
Phone +886 2 8751 1234

Littelfuse POWR-GARD® products and technical resources enhance the productivity and safety of electrical systems. POWR-GARD offers current-limiting fuses to decrease Arc-Flash exposure, fuse holders and fuse covers to reduce incidental contact, protection relays to safeguard equipment and safety resources to improve safety.

- Fuses and Fuse Holders
- Solar-Rated Products
- Relays and Controls
- Status Indication
- Safety by Design



LITTELFUSE.COM/SOLAR

For 35 years Littelfuse POWR-GARD® has helped OEM engineers, consulting engineers and end users select the right products to protect critical electrical equipment—supported by our full line of product catalogs and reference materials.

POWR-GARD Catalog

Littelfuse offers a complete circuit protection portfolio of industrial power fuses, including time-saving indication products for an instant visual blown-fuse identification, even on de-energized systems.

Relays & Controls Catalog

The comprehensive line of electronic and microprocessor-based protections relays and controls safeguard equipment and personnel to prevent expensive damage, downtime or injury due to electrical faults.

Varistor Catalog

Littelfuse offers industrial Metal Oxide Varistors (MOVs) to protect against transient voltage surges.



Littelfuse POWR-GARD is in the App Store!

Our free Littelfuse Catalogs and Literature App keeps our products and technical resources at your finger tips, wherever you are. Find products and technical specifications you need, quickly and easily!

Компания «Life Electronics» занимается поставками электронных компонентов импортного и отечественного производства от производителей и со складов крупных дистрибьюторов Европы, Америки и Азии.

С конца 2013 года компания активно расширяет линейку поставок компонентов по направлению коаксиальный кабель, кварцевые генераторы и конденсаторы (керамические, пленочные, электролитические), за счёт заключения дистрибьюторских договоров

Мы предлагаем:

- Конкуренеспособные цены и скидки постоянным клиентам.
- Специальные условия для постоянных клиентов.
- Подбор аналогов.
- Поставку компонентов в любых объемах, удовлетворяющих вашим потребностям.
- Приемлемые сроки поставки, возможна ускоренная поставка.
- Доставку товара в любую точку России и стран СНГ.
- Комплексную поставку.
- Работу по проектам и поставку образцов.
- Формирование склада под заказчика.
- Сертификаты соответствия на поставляемую продукцию (по желанию клиента).
- Тестирование поставляемой продукции.
- Поставку компонентов, требующих военную и космическую приемку.
- Входной контроль качества.
- Наличие сертификата ISO.

В составе нашей компании организован Конструкторский отдел, призванный помогать разработчикам, и инженерам.

Конструкторский отдел помогает осуществить:

- Регистрацию проекта у производителя компонентов.
- Техническую поддержку проекта.
- Защиту от снятия компонента с производства.
- Оценку стоимости проекта по компонентам.
- Изготовление тестовой платы монтаж и пусконаладочные работы.



Тел: +7 (812) 336 43 04 (многоканальный)

Email: org@lifeelectronics.ru