

High Voltage DC/DC Converter for Supertex Ultrasound Transmitter Demoboards

*By Afshaneh Brown, Applications Engineer,
and James Lei, Applications Manager*

Introduction

The Supertex AN-H59DB1 demoboard is a high voltage DC/DC converter. It can provide up to +90V voltage supply for V_{PP} and -90V for V_{NN} . It also provides +8.0 to +10V voltage supply for V_{DD} , floating power supplies of $V_{NN} +8.0$ to $V_{NN} +10V$ for V_{NF} and $V_{PP} -8.0$ to $V_{PP} -10V$ for V_{PF} . The input supply voltage is 12V.

The AN-H59DB1 circuitry consists of two high voltage PWM Current-Mode controllers, a DC/DC transformer driver, and three low dropout regulators. The Supertex AN-H59DB1 uses a high-voltage, current mode, PWM controller boost topology to generate +15 to +90V and a high-voltage current mode PWM controller buck-boost topology to generate -15 to -90V power supply voltage for Supertex HV738DB1 and HV748DB1 ultrasound transmitter demoboards.

Each of the transmitter demoboards has slightly different operating voltages as summarized below.

Board	V_{PP}	V_{NN}	V_{DD}	V_{PF}	V_{NF}
HV738DB1	+65V	-65V	+8.0V	$V_{PP} -8.0V$	$V_{NN} +8.0V$
HV748DB1	+75V	-75V	+9.0V	$V_{PP} -9.0V$	$V_{NN} +9.0V$

To accommodate all three demoboards, the AN-H59DB1 demoboard has adjustable V_{PP} , V_{NN} , V_{DD} , V_{PF} and V_{NF} . The purpose of the AN-H59DB1 is to aid in the evaluation of the three transmitter demoboards. The intention of this application note is to provide a general circuit description on how each of the output voltages is generated.

The VSUB pin on the HV738DB1 and HV748DB1 can either be connected to the most positive supply voltage on the demoboard, or can be left floating.

To power up the AN-H59DB1, ensure that the 3.3V power supply will be powered up first, and then the 12V power supply. The sequences on the HV738DB1 and HV748DB1 took into consideration using the protection diodes on each power line.

The circuit is shown in Figure 6, the component placement in Figure 5, and the bill of materials is at the end of this application note.

Application Circuit

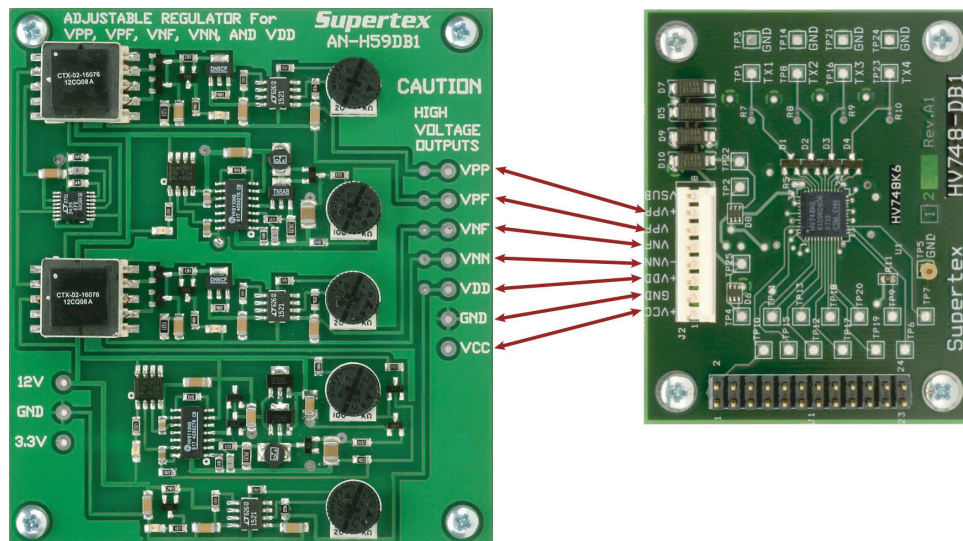

V_{PP} Circuit Description

The circuit in Figure 1 shows U5, the Supertex high voltage current mode PWM controller, being used to generate the high voltage power supply for V_{PP}. The maximum output power for V_{PP} was set for 10mA at 90V, which is 900mW. With an input voltage of 12V, a converter frequency of 110 kHz with a 100µH inductor was chosen to provide the desired output power.

The converter frequency is set by an external resistor, R20, across OSC_{IN} and OSC_{OUT} pins of U5. A 154kΩ resistor will set the frequency to about 110 kHz. R24 is the current sense resistor. 2.2Ω was used to set the maximum peak current limit to about 450mA. An RC filter, R23 and C15, is added between the current sense resistor and the current sense terminal pin 3 of U5. This reduces the leading edge spike on R24 from entering the current sense pin.

Inductor L1 is being charged from the 12V input by M3. When M3 turns off, the energy in L1 is discharged into C16, which is the V_{PP} output through D8. The V_{PP} voltage is divided down by feedback resistors R25, R26, and R27. The wiper of R26 is connected to pin 14 of U5. The overall converter will regulate the voltage on pin 14 to 4.0V. Different V_{PP} output voltages can be obtained by adjusting R26.

When the wiper for R26 is set to the top, V_{PP} can be calculated as:

$$V_{PP} = V_{FB} \times \left(\frac{R25 + R26 + R27}{R26 + R27} \right)$$

where V_{FB} is 4.0V

$$V_{PP} = 4.0V \times \left(\frac{232k + 100k + 14.3k}{100k + 14.3k} \right) = 12.1V$$

When the wiper for R26 is set to the bottom, V_{PP} can be calculated as:

$$V_{PP} = V_{FB} \times \left(\frac{R25 + R26 + R27}{R27} \right)$$

$$V_{PP} = 4.0V \times \left(\frac{232k + 100k + 14.3k}{14.3k} \right) = 96.9V$$

By adjusting potentiometer R26, V_{PP} meets the adjustable target range of 15 to 90V.

Comparator U6 will turn on LED D7 when the V_{PP} output is out of regulation due to excessive load. During initial power up, C16 will be at 0V. D7 is therefore expected to be on until C16 is charged to the desired regulation voltage.

Figure 1: Adjustable V_{PP} Power Supply

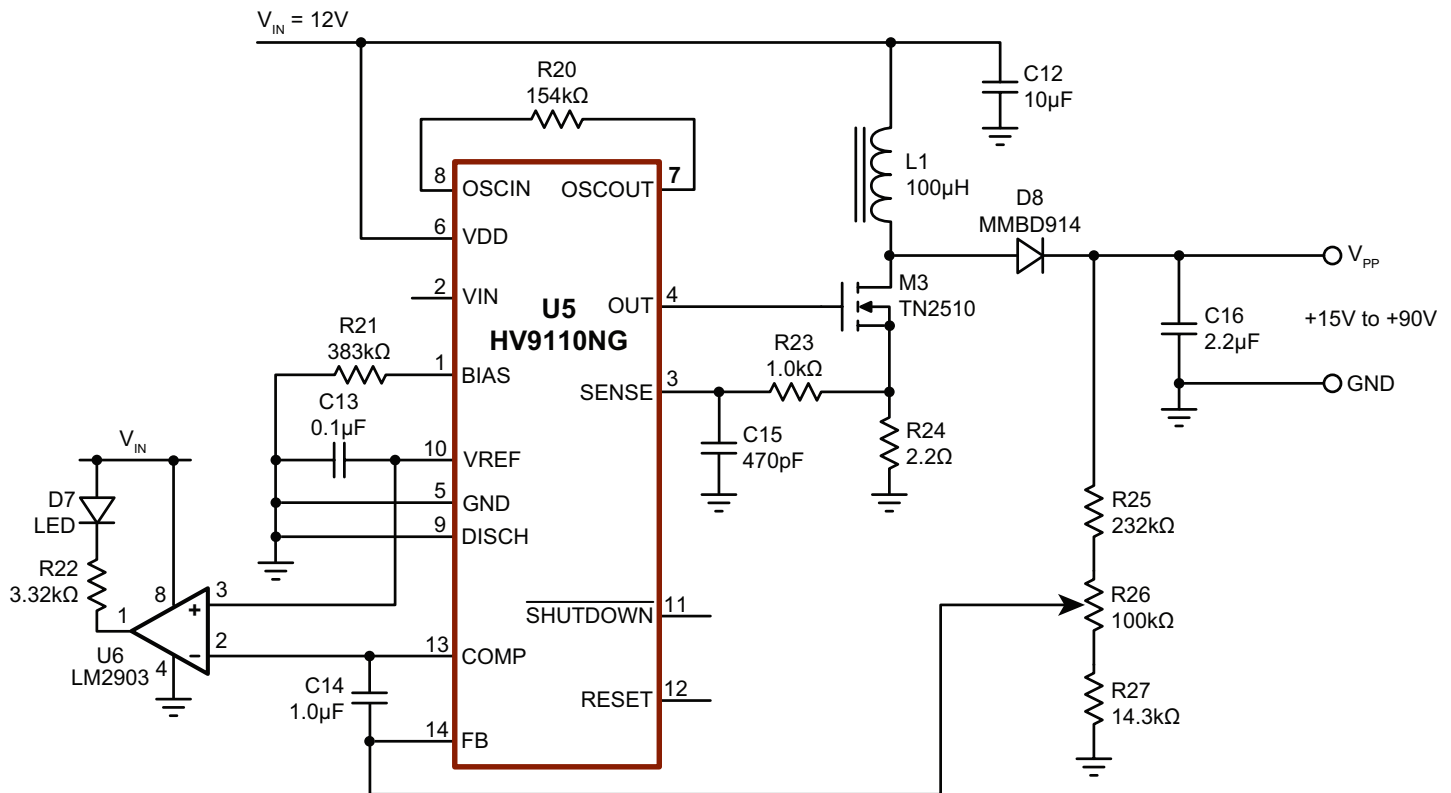

V_{NN} Circuit Description

The circuit in Figure 2 shows U7, the Supertex high voltage current mode PWM controller, being used to generate the high voltage power supply for V_{NN}. The function of U7 is very similar to what was described in the V_{PP} circuit description for U5. However, in this circuit a negative voltage is generated from a positive input voltage source, therefore requiring a buck-boost topology. The maximum output power for V_{NN} was set for -10mA at -90V which is 900mW. With an input voltage of 12V, a converter frequency of 110 kHz with a 100µH inductor was chosen to provide the desired output power.

Inductor L2 is being charged from the 12V input by the parallel combination of M6 and M7. When M6 and M7 turn off, the energy in L2 is discharged into C23, which is the V_{NN} output through D10. M6 and M7 are high voltage P-channel MOSFETs. U7 is designed to drive a high voltage N-channel MOSFET. The drive output for U7 therefore needs to be inverted. This is accomplished by M4 and M5.

The feedback voltage that U7 detects on pin 14 is +4.0V. The V_{NN} that needs to be sensed is a negative voltage. A circuit is needed to make sure the feedback voltage is positive. This consists of Q4, Q5, R33, R34, R35, R37, and R38. Q4 becomes a constant current sink set by the V_{NN} voltage and R35. The same current will be flowing through R33 and R34.

The voltage on the base of Q5 will be V_{IN} minus the voltage drop across the sum of R33 and R34. By varying R34, the base voltage on Q5 will change. Q5 becomes a constant current source with a value set by its base voltage and R37. The current source of Q5 is going into R38, which creates a positive voltage that is now proportional to the magnitude of V_{NN}.

$$V_{NN} = V_{BE} - \left(\frac{R35}{R33 + R34} \right) \times (V_{BE} + V_{FB} \times \frac{R37}{R38}),$$

where V_{BE} = 0.6V, V_{FB} = 4.0V.

When R34 is set to 100k, V_{NN} is calculated to be:

$$V_{NN} = 0.6V - \left(\frac{273k}{4.99k + 100k} \right) \times (0.6V + 4.0V \times \frac{14.7k}{40.2k}) = -4.0V$$

When R34 is set to 0k, V_{NN} is calculated to be:

$$V_{NN} = 0.6V - \left(\frac{273k}{4.99k + 0k} \right) \times (0.6V + 4.0V \times \frac{14.7k}{40.2k}) = -97.4V$$

By adjusting potentiometer R34, V_{NN} meets the adjustable target range of -15 to -90V.

Comparator U8 will turn on LED D9 when the V_{NN} output is out of regulation due to excessive load. During initial power up, C23 will be at 0V. D9 is therefore expected to be on until C23 is charged to the desired regulation voltage.

Figure 2: Adjustable V_{NN} Power Supply

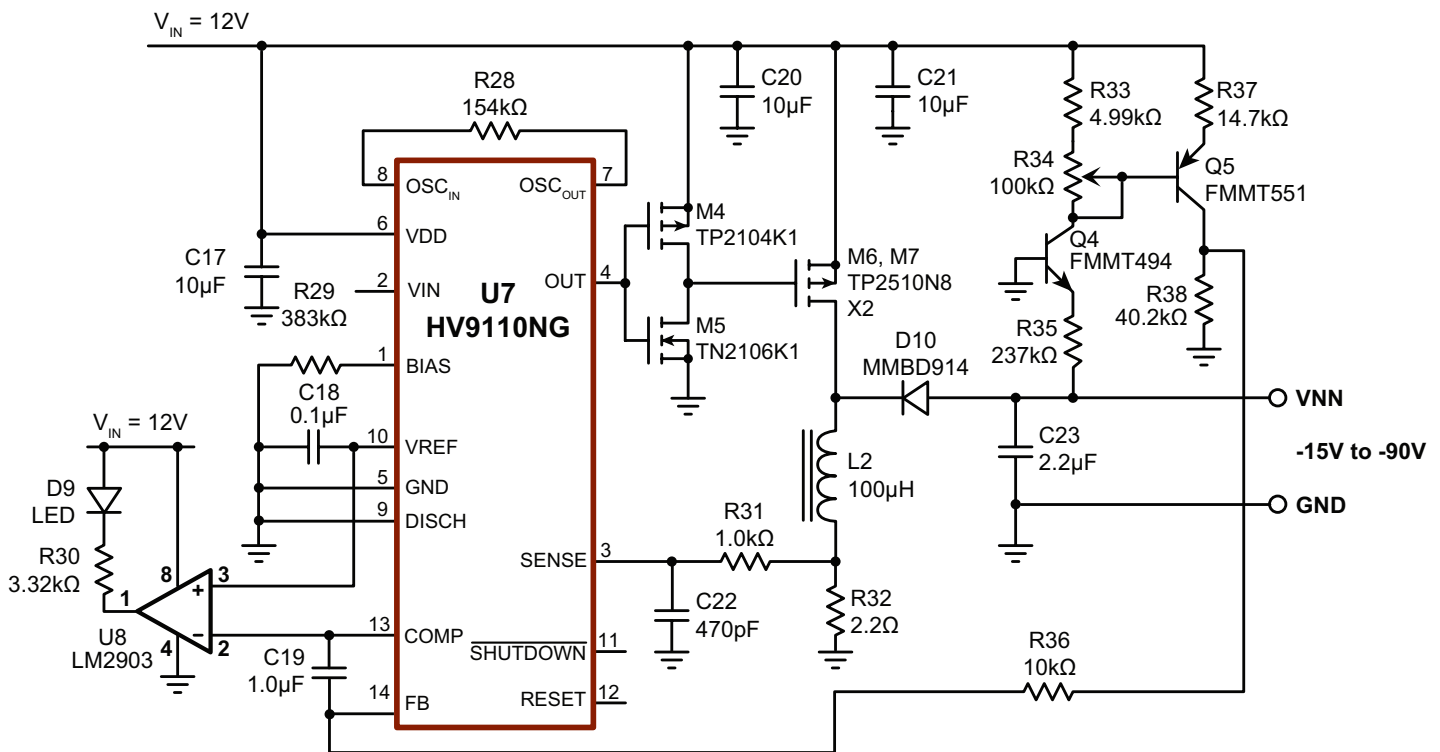

VPF and VNF Circuit Description

The three transmitter demoboard require two floating low voltage supplies, V_{PF} and V_{NF} . The floating supplies need to be adjustable to accommodate the different operating requirements for the three different boards. The V_{PF} is 8.0 to 10V below the high voltage V_{PP} positive supply. The V_{NF} is 8.0 to 10V above the high voltage V_{NN} negative supply. The two floating supplies are generated by using two isolated transformers, T1 and T2, and an isolated transformer driver, U1, as shown in Figure 4. Both outputs utilize adjustable low dropout linear regulators, U2 and U3, as shown in Figure 3. U2 and U3 are both Linear Technology LT1521, which has a reference voltage of 3.75V on the ADJ pin. For V_{PF} , resistors R6, R7, and R8 set the output V_{PF} voltage. R7 is a potentiometer for adjusting V_{PF} . V_{PF} can be calculated with the following equation:

$$V_{PF} = V_{ADJ} \times \left(\frac{R6 + R7 + R8}{R7 + R8} \right)$$

When R7 is set to 20k Ω , V_{PF} becomes:

$$V_{PF} = 3.75V \times \left(\frac{45.3k + 20k + 24.9k}{20k + 24.9k} \right) = 7.53V$$

When R7 is set to 0 Ω , V_{PF} becomes:

$$V_{PF} = 3.75V \times \left(\frac{45.3k + 0k + 24.9k}{0 + 24.9k} \right) = 10.6V$$

Please note that the OUT pin on U2 is referenced to V_{PP} , thereby setting V_{PF} to be 8.0 to 10V below V_{PP} . V_{NF} can also be calculated in a similar manner using resistors R12, R13, and R14. Please note that the GND pin on U3 is referenced to V_{NN} , thereby setting V_{NF} to be 8.0 to 10V above V_{NN} .

LED indicators, D5 and D11, start to turn on when the input current to U2 and U3 reaches an arbitrary value of 40mA. This is set by Q1 and R3 for V_{PF} and Q2 and R9 for V_{NF} . The input current can be calculated with the following equation:

$$\text{Input current} = \frac{V_{EB}}{R} = \frac{0.5V}{12.1\Omega} = 41.3mA$$

50mA current limits are added to protect against output shorts. The current limiter consists of a depletion-mode MOSFET and a series source resistor. The resistor sets the current limit and can be estimated with the following equation:

$$R_{SERIES} = \frac{V_{TH}}{I_{LIM}} \times (\sqrt{I_{LIM} / I_{DSS}} - 1) \text{ where,}$$

V_{TH} = pinch-off voltage for M1 and M2: -2.5V

I_{LIM} = desired current limit: 50mA

I_{DSS} = saturation current for M1 and M2: 1.1A

$R_{SERIES} = 39.3\Omega$. A 40.2 Ω resistor was used.

Figure 3: Adjustable V_{PF} and V_{NF} Power Supply

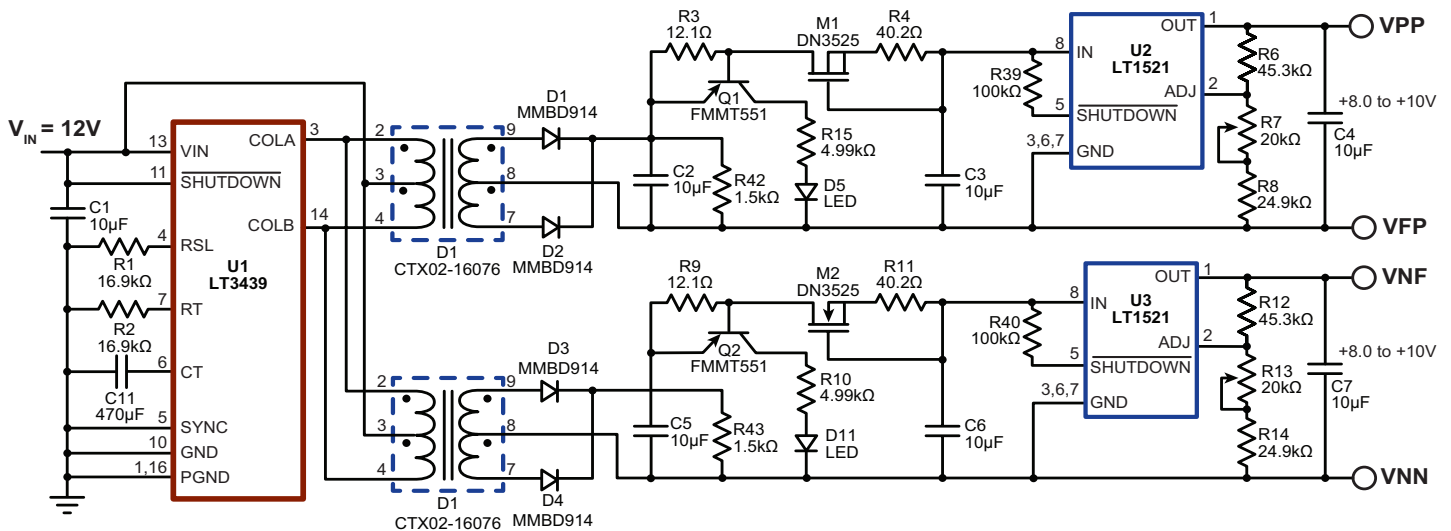

V_{DD} Circuit Description

The V_{DD} output voltage utilizes an adjustable low dropout linear regulator, U4 LT1521, as shown in Figure 4. The desired adjustable output voltage range is 8.0 to 10V to accommodate the different operating V_{DD} voltages for the three different transmitter demoboards.

The LT1521 has a reference voltage of 3.75V on the adj pin. Resistors R17, R18, and R19 set the output V_{DD} voltage. R18 is a potentiometer for adjusting V_{DD}. V_{DD} can be calculated with the following equation:

$$V_{DD} = V_{ADJ} \times \left(\frac{R17 + R18 + R19}{R18 + R19} \right)$$

When R18 is set to 20kΩ, V_{DD} becomes:

$$V_{DD} = 3.75V \times \left(\frac{45.3k + 20k + 24.9k}{20k + 24.9k} \right) = 7.53V$$

When R18 is set to 0Ω, V_{DD} becomes:

$$V_{DD} = 3.75V \times \left(\frac{45.3k + 0k + 24.9k}{0 + 24.9k} \right) = 10.6V$$

An LED indicator, D6, is included in case of excessive input, I_{IN}, current. D6 starts to turn on when the input current reaches an arbitrary value of 20mA. This is set by Q3 and R15. When the emitter-base junction of Q3 is forward biased (0.5V), Q3 will start to turn on, thereby forward biasing D6. The I_{IN} value to turn D6 on can be calculated with the following equation:

$$I_{IN} = \frac{V_{EB}}{R15} = \frac{0.5V}{24.3\Omega} = 20.6mA$$

Figure 4: Adjustable V_{DD} Power Supply

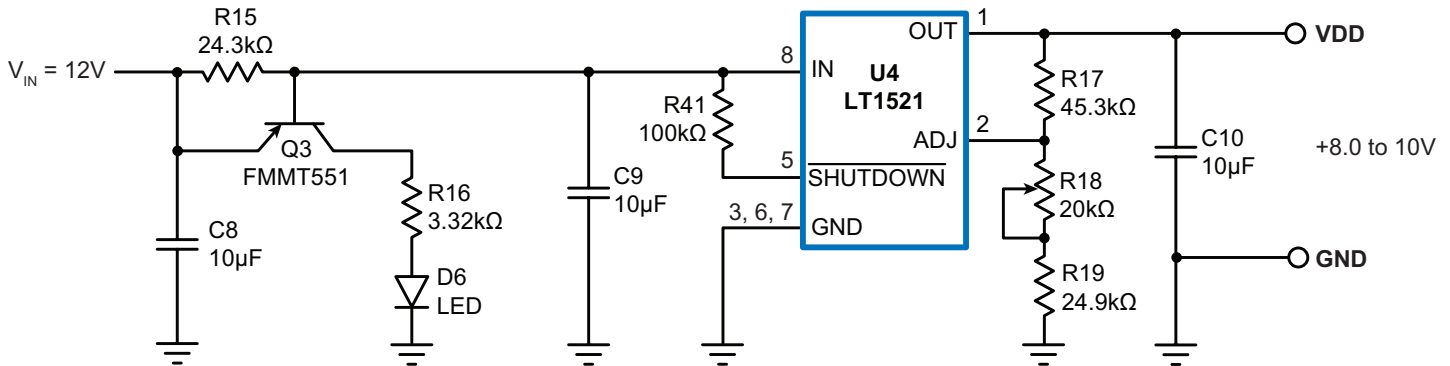

3.3V Input Terminal

The AN-H59DB1 has a 3.3V input terminal that is directly connected to the output terminal, V_{CC}. There is no circuitry on this board that uses the 3.3V supply. It is only there as a convenient connection to the 8-pin header. V_{CC} is the logic supply voltage for HV738DB1 and HV748DB1 and can operate from 1.2 to 5V. However, most users will operate V_{CC} at either 3.0 or 3.3V.

Input and Output Power

The output voltages from the AH-H59DB1 are all generated from the 12V input line. With no load on the outputs, the measured input current was about 70mA. This input current can vary from board to board due to variations in the isolated transformer.

The maximum output power is:

$$P_{OUT(MAX)} = P_{VPP(MAX)} + P_{VNN(MAX)} + P_{VPF(MAX)} + P_{VNF(MAX)} + P_{VDD(MAX)}$$

$$P_{OUT(MAX)} = 0.9W + 0.9W + 0.4W + 0.4W + 0.2W$$

$$P_{OUT(MAX)} = 2.8W$$

Under this condition, the 12V input current was measured to be 340mA. Input power is therefore 4.08W. This gives an approximate overall efficiency of 69% at full load.

VPF and VNF Output Current

The AN-H59DB1 can supply more than 40mA of current for the V_{PF} and V_{NF} outputs. The I_{NF} and I_{PF} input currents for the HV738 or the HV748 can be found in their respective data sheet but are summarized below:

Part #	IPF-mode 4	INF-mode 4
HV738	30mA	12mA
HV748	50mA	25mA

This is for continuous 5.0 MHz operation. For ultrasound, the high voltage transmitter is operating at very low duty cycles; 1% or lower. At a 1% duty cycle, the average current is expected to be a 100 times lower. The 40mA output current capability on the AN-H59DB1 is more than sufficient to power up the HV738 or the HV748.

Conclusion

The main purpose of AN-H59DB1 power supply demoboard is to help the evaluation of the Supertex HV738DB1 and HV748DB1 demoboards by reducing the number of power supplies needed. The AN-H59DB1 was designed to operate from a single 12V input which should be commonly available in any engineering laboratory.

The five on-board LEDs allow the user to quickly determine whether there is an overload condition on each of the supply lines. The five potentiometers allow the user to easily adjust each supply to meet their particular needs.

Figure 5: AN-H59 Component Placement

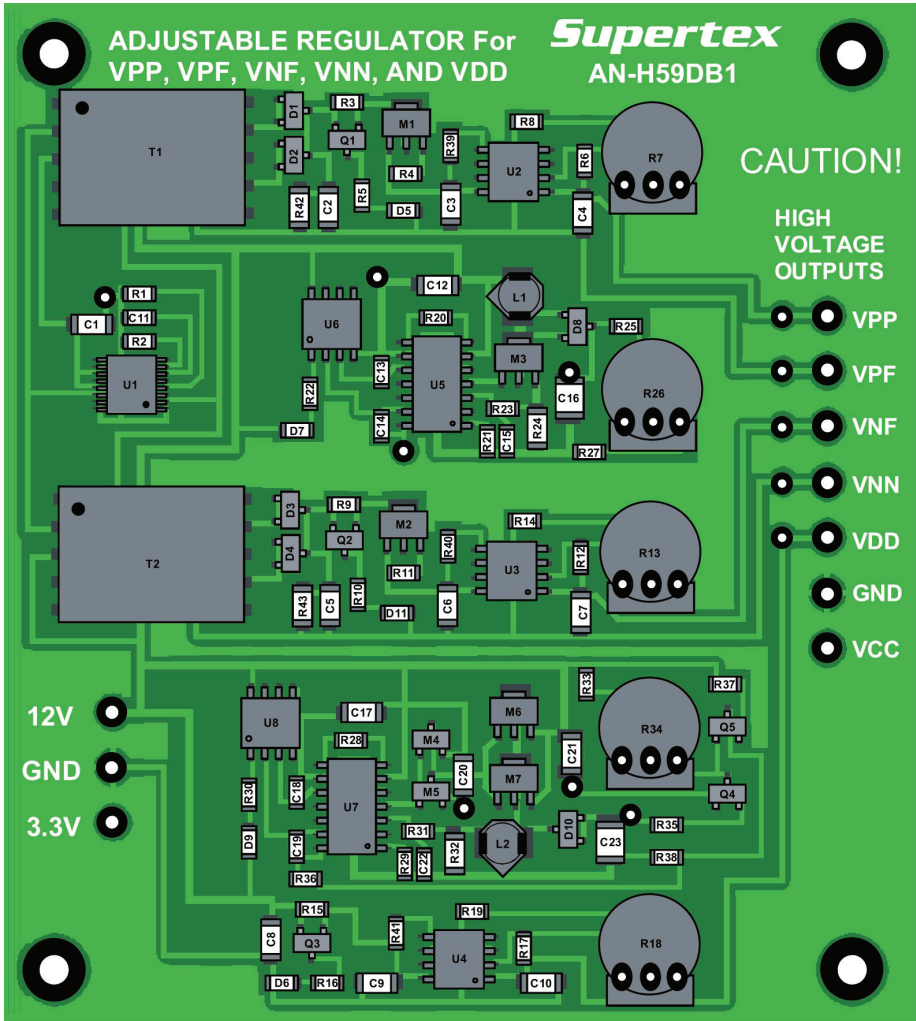
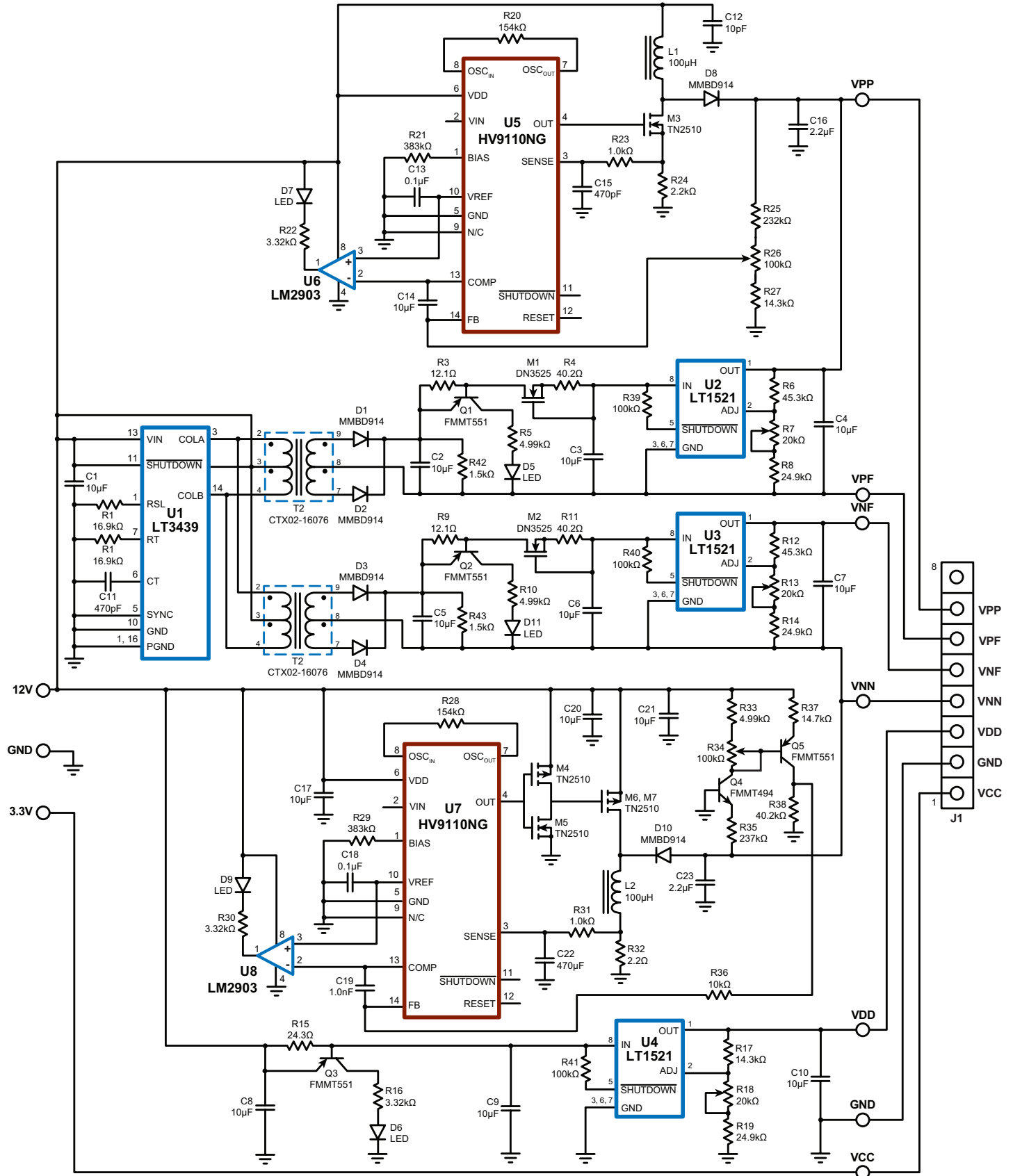

Figure 6: AN-H59 Circuit Schematic



Bill of Materials

Reference	Description	Package	Manufacturer	Part No.
C1, 2, 3, 4, 5, 6, 7, 8, 9, 10, 12, 17, 20, 21	Chip Capacitor, 10 μ F, 16V	1206	Any	---
C11, 15, 22	Chip Capacitor, 470pF, 100V	805	Any	---
C13, 18	Chip Capacitor, 0.1 μ F, 25V	805	Any	---
C14, 19	Chip Capacitor, 1.0nF, 50V	805	Any	---
C16, 23	Chip Capacitor, 2.2 μ F, 100V	1210	Any	---
R1, 2	16.9k Ω , Chip Resistor	805	Any	---
R3, 9	12.1 Ω , Chip Resistor	805	Any	---
R4, 11	40.2 Ω , Chip Resistor	805	Any	---
R5, 10, 33	4.99k Ω , Chip Resistor	805	Any	---
R6, 12, 17	45.3k Ω , Chip Resistor	805	Any	---
R7, 13, 18	20k Ω , Potentiometer	---	Any	---
R8, 14, 19	24.9k Ω , Chip Resistor	805	Any	---
R15	24.3 Ω , Chip Resistor	805	Any	---
R16, 22, 30	3.32k Ω , Chip Resistor	805	Any	---
R20, 28	154k Ω , Chip Resistor	805	Any	---
R21, 29	383k Ω , Chip Resistor	805	Any	---
R23, 31	1.02k Ω , Chip Resistor	805	Any	---
R24, 32	2.20 Ω , Chip Resistor	1206	Any	---
R25	232k Ω , Chip Resistor	0805	Any	---
R26, 34	100k Ω , Potentiometer	---	Any	---
R27	14.3k Ω , Chip Resistor	0805	Any	---
R35	237k Ω , Chip Resistor	0805	Any	---
R36	10.2k Ω , Chip Resistor	0805	Any	---
R37	14.7k Ω , Chip Resistor	0805	Any	---
R38	40.2k Ω , Chip Resistor	0805	Any	---
R39, 40, 41	100k Ω , Chip Resistor	0805	Any	---
R42,43	1.5k Ω , Chip Resistor	1206	Any	---
L1,2	Inductor, 100 μ H	---	Cooper Electronic	SD3814-101-R
D1, 2, 3, 4, 8, 10	100V, Fast Recovery Diode	SOT-23	Fairchild	MMBD914
D5, 6, 7, 9, 11	Red LED	0805	Lumex	SML-LXT0805SRW
Q1, 2, 3, 5	PNP, 60V, Bipolar Transistor	SOT-23	Zetex Inc	FMMT551TA
Q4	NPN, 120V, Bipolar Transistor	SOT-23	Zetex Inc	FMMT494TA
U1	IC, Low Noise Transformer Driver	16-TSSOP	Linear Technology	LT3439EFE#PBF
U2, 3, 4	IC, Adjustable Linear Regulator	SO-8	Linear Technology	LT1521CS8#PBF

Bill of Materials (cont.)

Reference	Description	Package	Manufacturer	Part No.
U5, 7	High-voltage current-mode PWM controller	SO-14	Supertex Inc.	HV9110NG-G
U6, 8	IC, Dual Voltage comparator	SO-8	Texas Instruments	LM2903DR
T1, 2	Transformer	---	Cooper Electronic	CTX02-16076
M1, 2	MOSFETs Depletion Mode, N-channel, 250V	SOT-89	Supertex Inc.	DN3525N8-G
M3	MOSFET Enhancement Mode, N-channel 100V	SOT-89	Supertex Inc.	TN2510N8
M4	MOSFET Enhancement Mode, P-channel 40V	SOT-23	Supertex Inc.	TP2104K1
M5	MOSFET Enhancement Mode, N-channel 60V	SOT-23	Supertex Inc.	TN2106K1
M6, 7	MOSFETs Enhancement Mode, P-Channel 100V	SOT-89	Supertex Inc.	TP2510N8
J1	8 Position, 0.100" Pitch, rectangular connector	---	Tyco Electronic Amp	770602-8

Supertex inc. does not recommend the use of its products in life support applications, and will not knowingly sell them for use in such applications unless it receives an adequate "product liability indemnification insurance agreement." **Supertex inc.** does not assume responsibility for use of devices described, and limits its liability to the replacement of the devices determined defective due to workmanship. No responsibility is assumed for possible omissions and inaccuracies. Circuitry and specifications are subject to change without notice. For the latest product specifications refer to the **Supertex inc.** (website: <http://www.supertex.com>)

Компания «Life Electronics» занимается поставками электронных компонентов импортного и отечественного производства от производителей и со складов крупных дистрибьюторов Европы, Америки и Азии.

С конца 2013 года компания активно расширяет линейку поставок компонентов по направлению коаксиальный кабель, кварцевые генераторы и конденсаторы (керамические, пленочные, электролитические), за счёт заключения дистрибьюторских договоров

Мы предлагаем:

- Конкуренспособные цены и скидки постоянным клиентам.
- Специальные условия для постоянных клиентов.
- Подбор аналогов.
- Поставку компонентов в любых объемах, удовлетворяющих вашим потребностям.
- Приемлемые сроки поставки, возможна ускоренная поставка.
- Доставку товара в любую точку России и стран СНГ.
- Комплексную поставку.
- Работу по проектам и поставку образцов.
- Формирование склада под заказчика.
- Сертификаты соответствия на поставляемую продукцию (по желанию клиента).
- Тестирование поставляемой продукции.
- Поставку компонентов, требующих военную и космическую приемку.
- Входной контроль качества.
- Наличие сертификата ISO.

В составе нашей компании организован Конструкторский отдел, призванный помогать разработчикам, и инженерам.

Конструкторский отдел помогает осуществить:

- Регистрацию проекта у производителя компонентов.
- Техническую поддержку проекта.
- Защиту от снятия компонента с производства.
- Оценку стоимости проекта по компонентам.
- Изготовление тестовой платы монтаж и пусконаладочные работы.



Тел: +7 (812) 336 43 04 (многоканальный)

Email: org@lifeelectronics.ru