

Inverted Thru Board Card Edge & Inverted Poke-In Platform Connectors

The Inverted Card Edge and Poke-In Platform Connectors provide 3.0 mm creep and clearance from all other conductive components on FR4 and metal clad printed circuit boards. The 2 position connectors share the same printed circuit board footprint while offering flexibility in providing either a direct power driver board one piece mating solution or a poke-in wire connection to the underside of the LED array boards.

PRODUCT BENEFITS

- The ITB connectors are surface mounted at the same time as other devices on the PCB eliminating secondary processes
- Low profile, space-saving connector designed with and without a cover. The 1.55 mm without cover or 1.90 mm with cover height above the PCB minimizes LED light obstruction.
- Surface mount hold downs provide stability during driver board mating, un-mating and poke-in mating.
- Flat top surface allows for vacuum pick up
- Tape and reel packaging for high speed SMT processing
- Designed with round corners to minimize shadowing
- Both the Inverted Poke-in and Inverted Card Edge Connectors are available with an optional cap that provides for a touch safe design once soldered to the printed circuit board

APPLICATIONS

- Retrofit LED Bulbs
- Track Lighting
- Spot Lights
- Down Lights

MECHANICAL

Inverted Card Edge termination:

- Offered in two versions to accept 1.0 mm or 1.6 mm driver boards
- Polarity keying retention feature options provide additional retention force
- 5 mating cycles

Inverted Poke-In Termination:

- Offered in two versions for poke-in termination of 18 AWG stranded and 18-22 AWG solid and pre-bonded wire or 24-26 AWG solid wire
- Added 1 mm depth dimension to accommodate the wire insulation guide barrels
- Single insertion mating

ELECTRICAL

- Operating Voltage: 400 VAC / VDC
- Operating Current : 3 A, Inverted Card Edge and 18-22 AWG Poke-In
2 A, 24-26 AWG Poke-In
- Operating Temperature: -20 to 130°C
- 3 mm creep and clearance from contacts to MCPCB substrate for non-isolated line voltage power supplies (dielectric withstand voltage)

MATERIALS

- Housing and Cover: 94 V-0 rated high temperature resistant thermoplastic
- Contacts: Tin over nickel plated copper alloy

STANDARDS AND SPECIFICATIONS

- UL 1977
- CSA Std. C22.2 No. 182.3
- Product Specification: **108-32041**
- Application Specification: **108-32054**

te.com/ib



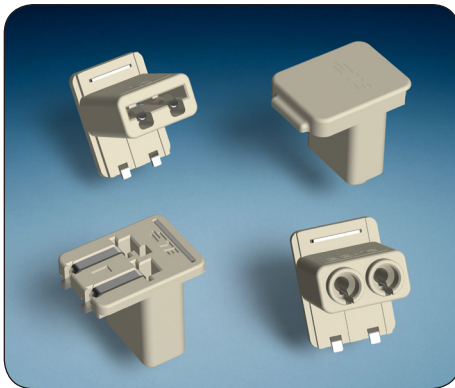

PRODUCT OFFERING

Part Number	Inverted Through Board Connector Style	Board Thickness	Wire Gauge
2213188-1	Card Edge	1.0 mm	
2213188-2	Card Edge	1.6 mm	
2213188-3	Card Edge with Pre-installed Cover	1.0 mm	
2213188-4	Card Edge with Pre-installed Cover	1.6 mm	
2213189-1	Poke-In		18-22 AWG
2213189-2	Poke-In		24-26 AWG
2213189-3	Poke-In with Pre-installed Cover		18-22 AWG
2213189-4	Poke-In with Pre-installed Cover		24-26 AWG

PRODUCT DIMENSIONS

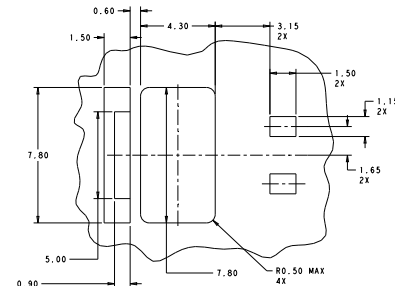
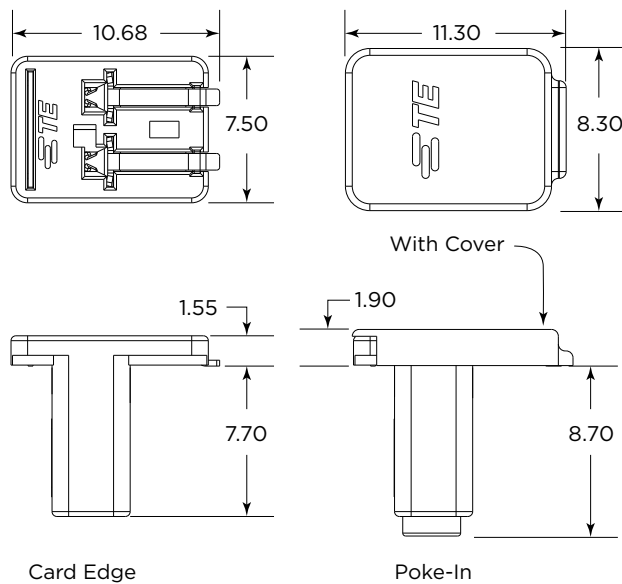

Board Layout

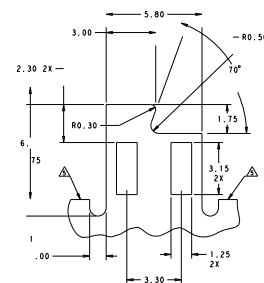

Mating PCB detail

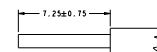

Wire preparation detail

While TE has made every reasonable effort to ensure the accuracy of the information in this brochure, TE does not guarantee that it is error-free, nor does TE make any other representation, warranty or guarantee that the information is accurate, correct, reliable or current. TE reserves the right to make any adjustments to the information contained herein at any time without notice. TE expressly disclaims all implied warranties regarding the information contained herein, including, but not limited to, any implied warranties of merchantability or fitness for a particular purpose. The dimensions in this catalog are for reference purposes only and are subject to change without notice. Specifications are subject to change without notice. Consult TE for the latest dimensions and design specifications.

te.com/ib



Компания «Life Electronics» занимается поставками электронных компонентов импортного и отечественного производства от производителей и со складов крупных дистрибьюторов Европы, Америки и Азии.

С конца 2013 года компания активно расширяет линейку поставок компонентов по направлению коаксиальный кабель, кварцевые генераторы и конденсаторы (керамические, пленочные, электролитические), за счёт заключения дистрибьюторских договоров

Мы предлагаем:

- Конкурентоспособные цены и скидки постоянным клиентам.
- Специальные условия для постоянных клиентов.
- Подбор аналогов.
- Поставку компонентов в любых объемах, удовлетворяющих вашим потребностям.
- Приемлемые сроки поставки, возможна ускоренная поставка.
- Доставку товара в любую точку России и стран СНГ.
- Комплексную поставку.
- Работу по проектам и поставку образцов.
- Формирование склада под заказчика.
- Сертификаты соответствия на поставляемую продукцию (по желанию клиента).
- Тестирование поставляемой продукции.
- Поставку компонентов, требующих военную и космическую приемку.
- Входной контроль качества.
- Наличие сертификата ISO.

В составе нашей компании организован Конструкторский отдел, призванный помогать разработчикам, и инженерам.

Конструкторский отдел помогает осуществить:

- Регистрацию проекта у производителя компонентов.
- Техническую поддержку проекта.
- Защиту от снятия компонента с производства.
- Оценку стоимости проекта по компонентам.
- Изготовление тестовой платы монтаж и пусконаладочные работы.



Тел: +7 (812) 336 43 04 (многоканальный)

Email: org@lifeelectronics.ru