



## Addressable 5mm RGB DIP Board



### Product Description



this is a full board in 66mm Diameter

there are many hole in center of the board which are for mounting purpose.

looks like it consist by 3 circle ,but it's not removeable as it's a full sheet.

44pcs addressable DIP 5mm lamp, both in and output Soldering Pad on back side of the PCB, 5 VCC operation, SPI signal.



## Product Datasheet

Product	Number	M066044XA3SF
LED	Quantity	44 leds
Explicit	index	80
LED	Type	DIP 5mm RGB
Color		RGB
Size	(mm)	66mmØ
Luminous intensity		R=44000mcd ,G=55000mcd ,B=66000mcd
IP	Level	IP20
Beam	Angle	270°
Guarantee quality		1 years

## Outline Dimension

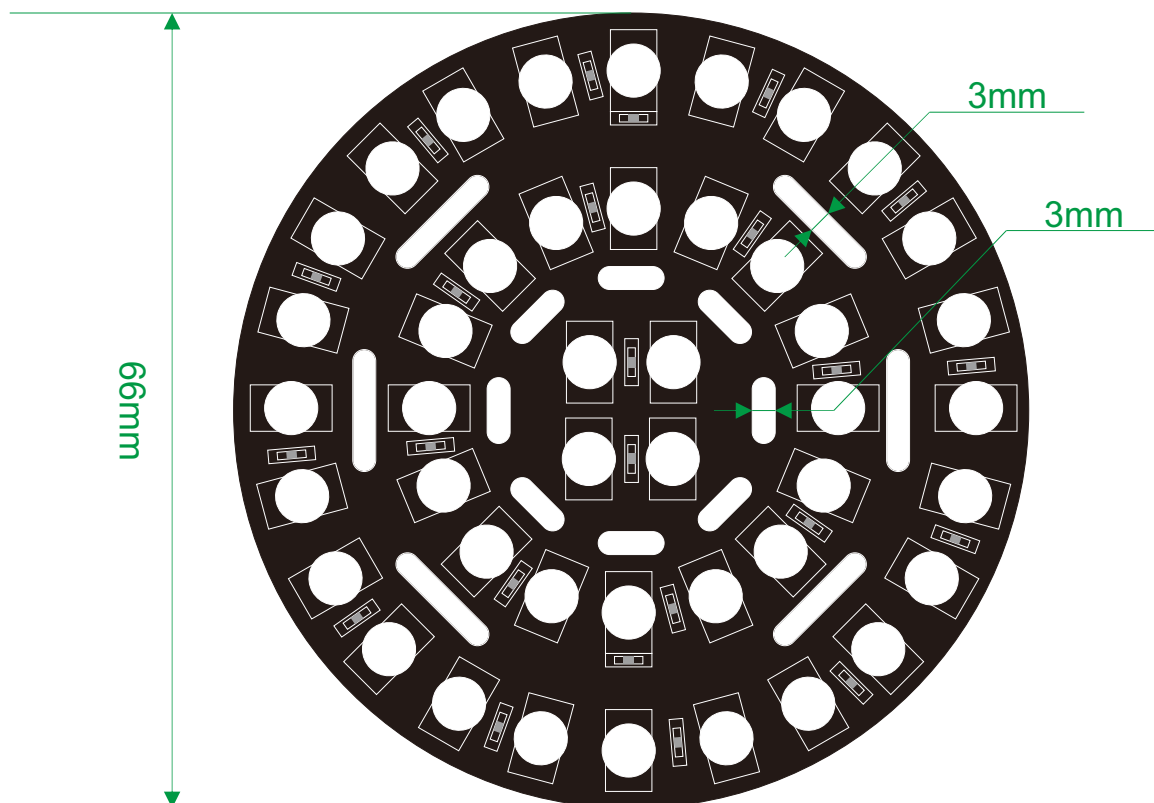



**\*The following is the lamp details**

## SPECIFICATION SHEET

**Description:**

- 4.8\*5.8MM
- Lens Color: Water Clear
- Emitting Color: RGB
- Viewing Angle :270°

CUSTOMER APPROVED SIGNATURES	APPROVED BY	CHECKED BY	PREPARED BY



## Description :

5mm WS2812B straw hat LED is a light emitting diode with integrated digital control circuit in shape of 5mm Straw hat. Each lighting element is a pixel. The intensities of the pixels are contained within the intelligent digital interface input. The output is driven by patented PWM technology, which effectively guarantees high consistency of the color of the pixels. The control circuit consists of a signal shaping amplification circuit, a built-in constant current circuit, and a high precision RC oscillator.

The data protocol being used is uni-polar NRZ communication mode. The 24-bit data are transmitted from the controller to DIN of the first element, and if it is accepted it is extracted pixel to pixel. After an internal data latch, the remaining data pass through the internal amplification circuit and send out on the DO port to the remaining pixels. The pixel is reset after the end of DIN. Using automatic shaping forwarding technology makes the number of cascaded pixels without signal transmission only limited by signal transmission speed.

The LED has a low driving voltage (which allows for environmental protection and energy saving), high brightness, scattering angle, good consistency, low power, and long life. The control circuit is integrated in the LED above.

## Main Application Field:

- Full color LED string light, LED full color module, LED guardrail tube, LED appearance / scene lighting, spot light for advertising
- LED point light, LED pixel screen, LED shaped screen, a variety of electronic products, electrical equipment etc..

## Description:

- LED internal integrated high quality external control line serial cascade constant current IC;
- control circuit and the RGB chip in Lamps LED components, to form a complete control of pixel, color mixing uniformity and consistency;
- built-in data shaping circuit, a pixel signal is received after wave shaping and output waveform distortion will not guarantee a line;
- The built-in power on reset and reset circuit, the power does not work;
- gray level adjusting circuit (256 level gray scale adjustable);
- red drive special treatment, color balance;
- line data transmission;
- plastic forward strengthening technology, the transmission distance over 10m;
- Using a typical data transmission frequency of 800 Kbps with refreshing rate of 30 frames/sec.



## Mechanical

Dimension :

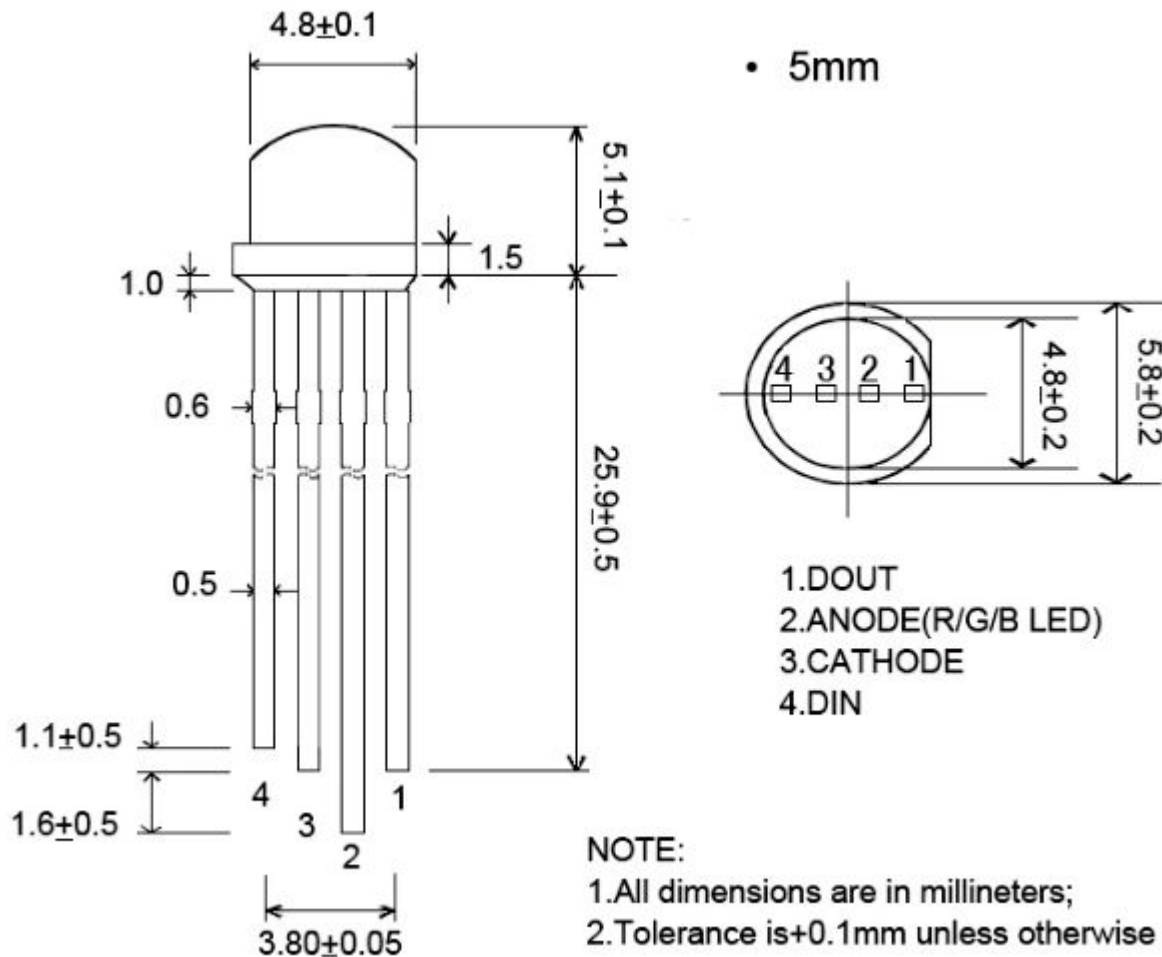

NO.	Symbol	Function description
1.	DOUT	Control data signal output
2.	VDD	Power supply LED
3.	VSS	Ground
4.	DIN	Control data signal input

## Absolute Maximum Ratings (Ta=25°C, VSS=0V )

Parameter	Symbol	Range	Unit
Power supply voltage	VDD	+3.5~+5.5	V
Logic input voltage	VIN	-0.5~VDD+0.5	V
Working temperature	T <sub>opt</sub>	-40~+85	°C
Storage temperature	T <sub>stg</sub>	-50~+150	°C
ESD pressure	VESD	4K	V



## Electrical/Optical Characteristics (TA=25°C, VDD=5.0V, VSS=0V)

### RED COLOR :

Parameter	Symbol	Min	Typ.	Max	Unit	Test Condition
Forward voltage	$V_F$	1.8	2.0	2.2	V	IF=20 mA
Luminous intensity	$I_V$	1000	1250	1500	mcd	IF=20 mA
Peak emission wavelength	$\lambda_p$	620	622.5	625	nm	v
Half intensity angle	$2\theta_{1/2}$	v	120	v	deg	v

### GREEN COLOR :

Parameter	Symbol	Min	Typ.	Max	Unit	Test Condition
Forward voltage	$V_F$	3.0	3.2	3.4	V	IF=20 mA
Luminous intensity	$I_V$	1500	1850	2200	mcd	IF=20 mA
Peak emission wavelength	$\lambda_p$	520	522.5	525	nm	v
Half intensity angle	$2\theta_{1/2}$	v	120	v	deg	v

### BLUE COLOR :

Parameter	Symbol	Min	Typ.	Max	Unit	Test Condition
Forward voltage	$V_F$	3.0	3.2	3.4	V	IF=20 mA
Luminous intensity	$I_V$	700	850	1000	mcd	IF=20 mA
Peak emission wavelength	$\lambda_p$	465	467.5	470	nm	v
Half intensity angle	$2\theta_{1/2}$	v	120	v	deg	v

Parameter	Symbol	Min	Typical	Max	Unit	Test
The chip supply voltage	VDD	---	5.2	---	V	
R/G/B port pressure	VDS, MAX	---	---	26	V	
DOUT drive capability	IDOH	---	49	---	mA	DOUT conect ground, the maximum drive current
	IDOL	---	-50	---	mA	DOUT conect +, the largest current
The signal input flip threshold	VIH	3.4	---	---	V	VDD=5.0V
	VIL			1.6	V	
The frequency of PWM	FPWM	---	1.2	---	KHZ	
Static power consumption	IDD	---	1	---	mA	



## Dynamic Parameters (Ta=25°C):

Parameter	Symbol	Min	Typical	Max	Unit	Test
The speed of data transmission	fDIN	---	800	---	KHZ	The duty ratio of 67% (data 1)
DOUT transmission delay	TPLH	---	---	500	ns	DIN→DOUT
	TPHL	---	---	500	ns	
IOUT Rise/Drop Time	Tr		100		ns	VDS=1.5 IOUT=13mA

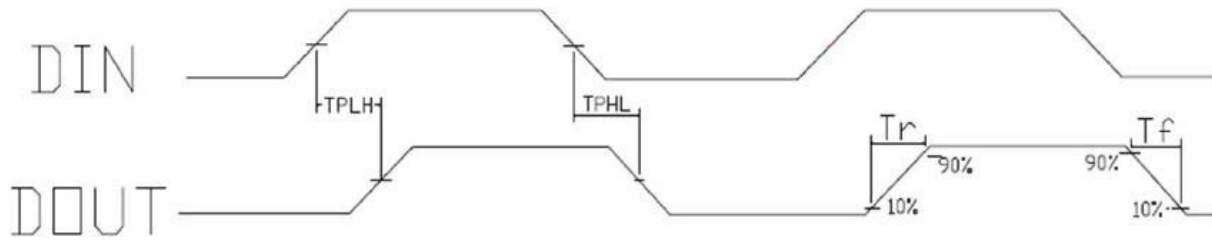

## The Data Transmission Time (TH+TL=1.25 μs ± 600ns):

T0H	0 code, high level time	0.3μs	±0.15μs
T0L	0 code, low level time	0.9μs	±0.15μs
T1H	1 code, high level time	0.6μs	±0.15μs
T1L	1 code, low level time	0.6μs	±0.15μs
Trst	Reset code, low level time	80μs	

## Timing waveform:

### Input code:

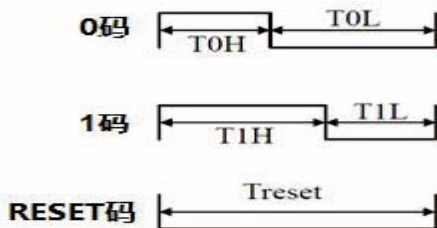

### Connction mode:

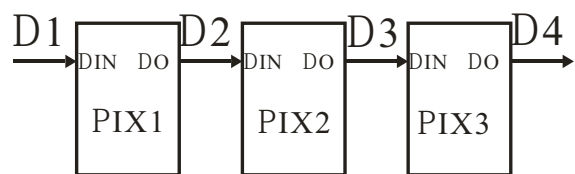



The **method** of data **transmission**:

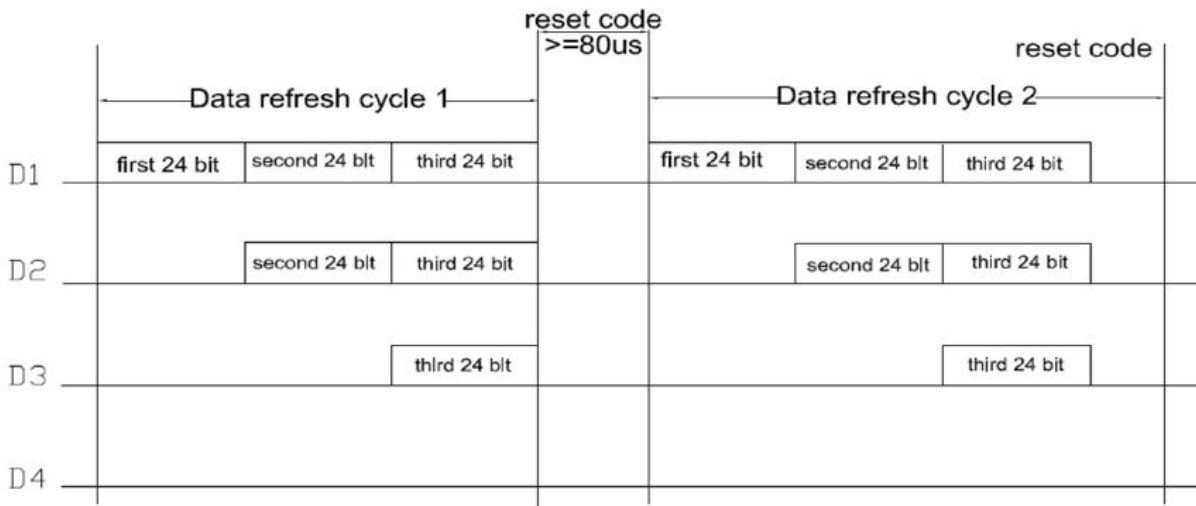

Note: the D1 sends data for MCU, D2, D3, D4 for data forwarding automatic shaping cascade circuit.

The data **structure** of 24bit:

G7	G6	G5	G4	G3	G2	G1	G0	R7	R6	R5	R4	R3	R2	R1	R0	B7	B6	B5	B4	B3	B2	B1	B0
----	----	----	----	----	----	----	----	----	----	----	----	----	----	----	----	----	----	----	----	----	----	----	----

Note: high starting, in order to send data (G7 - G6 - ..... ..B0)





The **typical application** circuit:

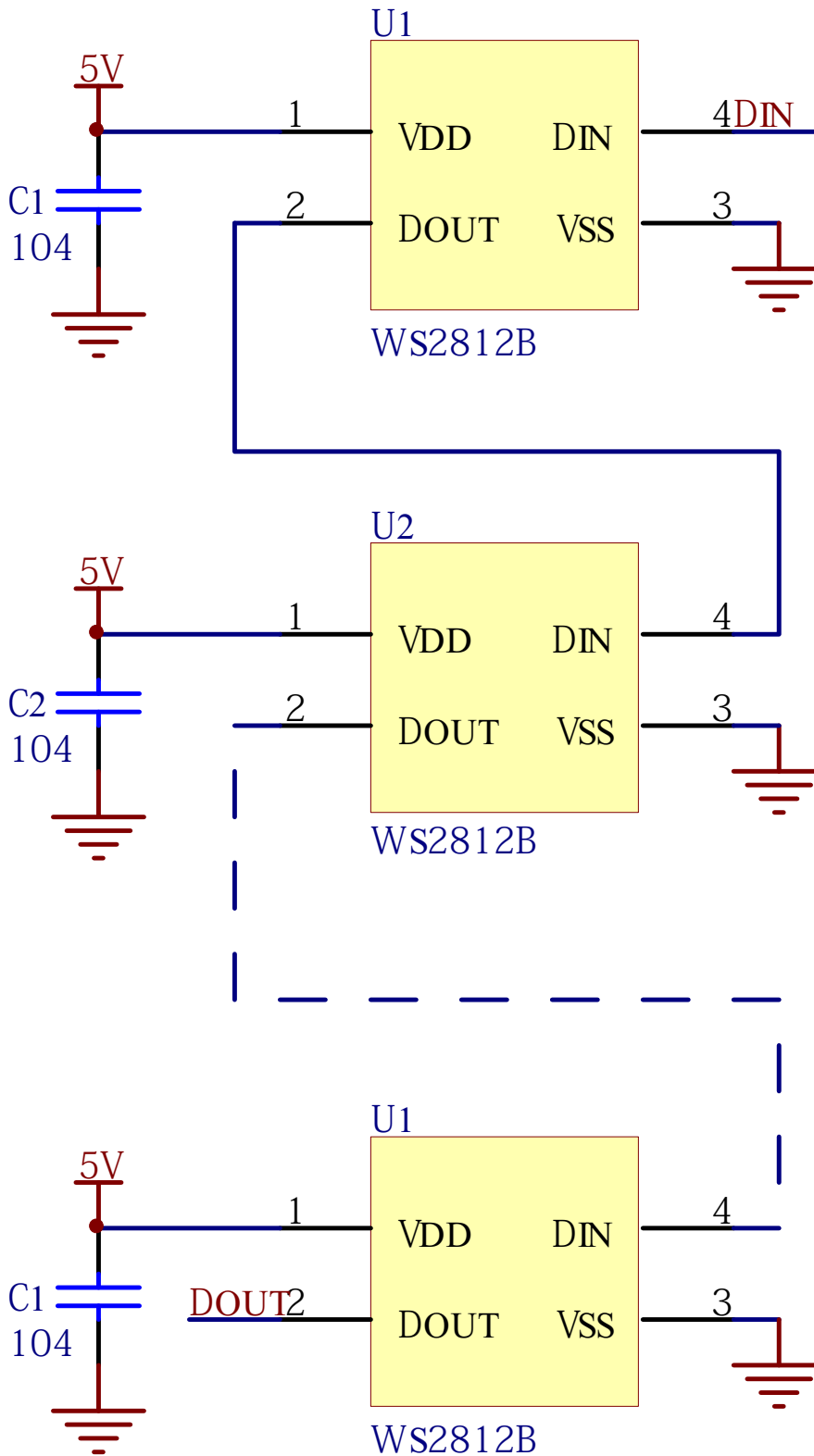



## Standard LED Performance Graph:

Typical Relative Luminous Flux vs. Forward Current

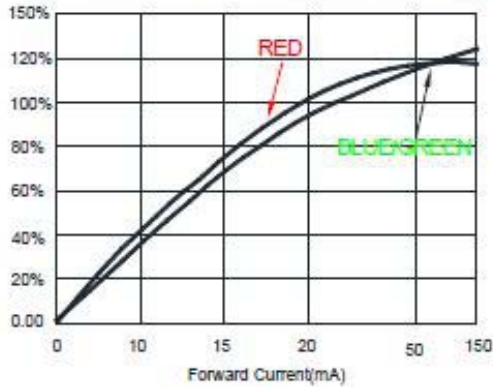

Forward Voltage vs. Forward Current

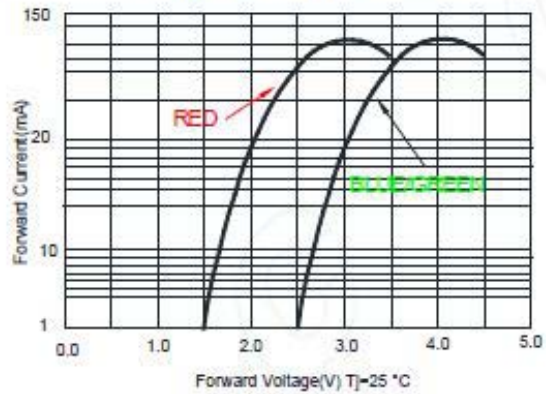

Thermal Pad Temperature vs. Relative Light Output

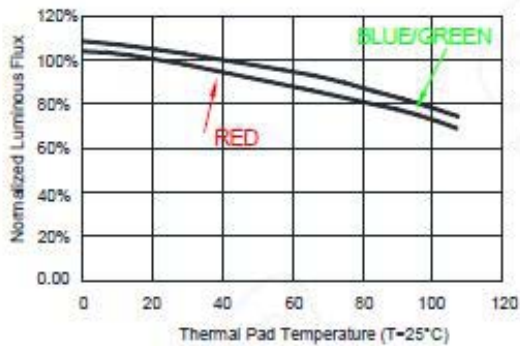

Wavelength Characteristics

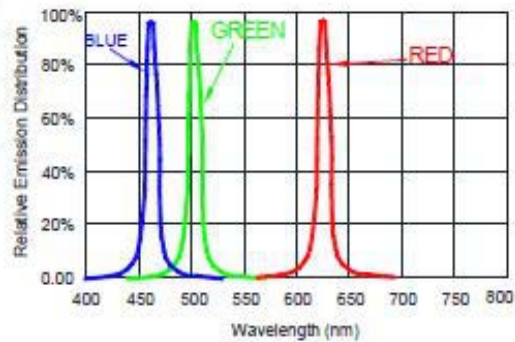

Thermal Pad Temperature vs. Forward Current

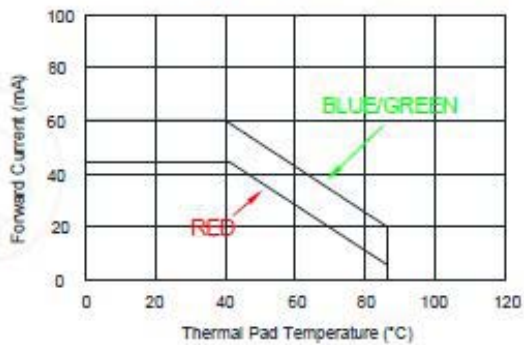

Typical Radiation Pattern 120°

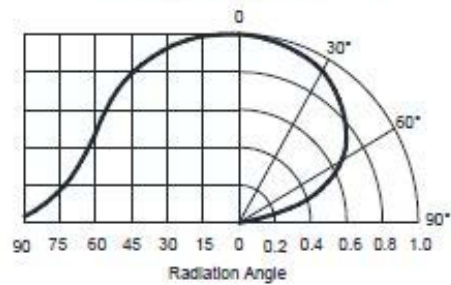

Компания «Life Electronics» занимается поставками электронных компонентов импортного и отечественного производства от производителей и со складов крупных дистрибьюторов Европы, Америки и Азии.

С конца 2013 года компания активно расширяет линейку поставок компонентов по направлению коаксиальный кабель, кварцевые генераторы и конденсаторы (керамические, пленочные, электролитические), за счёт заключения дистрибьюторских договоров

Мы предлагаем:

- Конкурентоспособные цены и скидки постоянным клиентам.
- Специальные условия для постоянных клиентов.
- Подбор аналогов.
- Поставку компонентов в любых объемах, удовлетворяющих вашим потребностям.
- Приемлемые сроки поставки, возможна ускоренная поставка.
- Доставку товара в любую точку России и стран СНГ.
- Комплексную поставку.
- Работу по проектам и поставку образцов.
- Формирование склада под заказчика.
- Сертификаты соответствия на поставляемую продукцию (по желанию клиента).
- Тестирование поставляемой продукции.
- Поставку компонентов, требующих военную и космическую приемку.
- Входной контроль качества.
- Наличие сертификата ISO.

В составе нашей компании организован Конструкторский отдел, призванный помогать разработчикам, и инженерам.

Конструкторский отдел помогает осуществить:

- Регистрацию проекта у производителя компонентов.
- Техническую поддержку проекта.
- Защиту от снятия компонента с производства.
- Оценку стоимости проекта по компонентам.
- Изготовление тестовой платы монтаж и пусконаладочные работы.



Тел: +7 (812) 336 43 04 (многоканальный)  
Email: [org@lifeelectronics.ru](mailto:org@lifeelectronics.ru)